

Panasonic

Camera/VTR

Operating Instructions

DVCPRO

Model No. **AJ-SDC615E**

DVCPRO 50

Model No. **AJ-SDC905E**

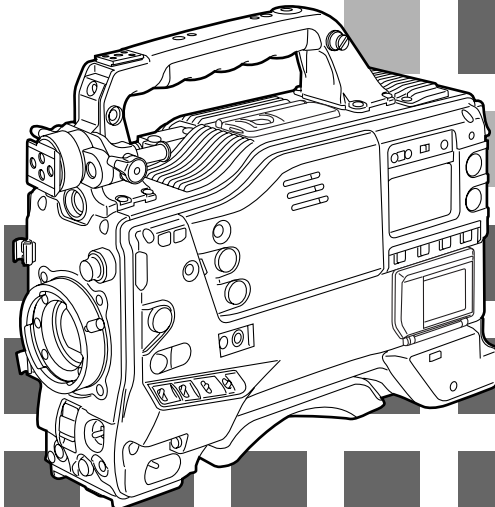

Before operating this product, please read the instructions carefully and save this manual for future use.

■ **DO NOT REMOVE PANEL COVER BY UNSCREWING.**

To reduce the risk of electric shock, do not remove cover. No user serviceable parts inside.
Refer servicing to qualified service personnel.

CAUTION:

TO REDUCE THE RISK OF FIRE OR SHOCK HAZARD, REFER MOUNTING OF THE OPTIONAL INTERFACE BOARD TO AUTHORIZED SERVICE PERSONNEL.

WARNING:

TO REDUCE THE RISK OF FIRE OR SHOCK HAZARD, KEEP THIS EQUIPMENT AWAY FROM ALL LIQUIDS—USE AND STORE ONLY IN LOCATIONS WHICH ARE NOT EXPOSED TO THE RISK OF DRIPPING OR SPLASHING LIQUIDS, AND DO NOT PLACE ANY LIQUID CONTAINERS ON TOP OF THE EQUIPMENT.

CAUTION:

TO REDUCE THE RISK OF FIRE OR SHOCK HAZARD AND ANNOYING INTERFERENCE, USE THE RECOMMENDED ACCESSORIES ONLY.

Lithium Battery

Warning

The lithium battery in this equipment must only be replaced by qualified personnel. When necessary, contact your local Panasonic supplier.

“The lithium battery is a critical component (type number CR2032 or BR2032 manufactured by Panasonic.)

It must never be subjected to excessive heat or discharge. It must therefore only be fitted in equipment designed specifically for its use.

Replacement batteries must be of the same type and manufacturer. They must be fitted in the same manner and location as the original battery, with the correct polarity connections observed.

Do not attempt to re-charge the old battery or re-use it for any other purpose. It should be disposed of in waste products destined for burial rather than incineration.”

CAUTION

Danger of explosion if battery is incorrectly replaced.

Replace only with the same or equivalent type recommended by the equipment manufacturer. Discard used batteries according to manufacturer’s instructions.

VARNING

Explosionsfara vid felaktigt batteribyte. Använd samma batterityp eller en ekvivalent typ som rekommenderas av apparattillverkaren. Kassera använt batteri enligt fabrikantens instruktion.

ADVARSEL!

Eksplussionsfare ved fejlagtig håndtering. Udskiftning må kun ske med batteri af samme fabrikat og type. Levér det brugte batteri tilbage til leverandøren.

VAROITUS

Paristo voi räjähtää, jos se on virheellisesti asennettu.

Vaihda paristo ainoastaan laitevalmistajan suosittelemaan tyyppiin. Hävitä käytetty paristo valmistajan ohjeiden mukaisesti.

 indicates safety information.

The descriptions contained throughout the text of these instructions apply to both the AJ-SDC615 and AJ-SDC905. However, descriptions which apply solely to the AJ-SDC615 are indicated by **SDC615**; similarly, descriptions which apply solely to the AJ-SDC905 are indicated by **SDC905**.

Attention/Attentie

- Batteries are used for the main power source and memory back-up in the product.
At the end of their useful life, you should not throw them away.
Instead, hand them in as small chemical waste.
- Voor de primaire voeding en het reservegeheugen van het apparaat wordt gebruikgemaakt van een batterij.
Wanneer de batterij is uitgeput, mag u deze niet gewoon weggooien, maar dient u deze als klein chemisch afval weg te doen.

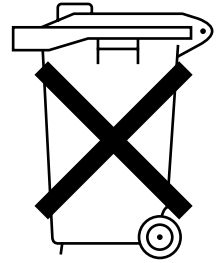

To remove the battery/Verwijderen van de batterij

Main Power Battery (Ni-Cd Battery)

Batterij Voor Primaire Voeding (Nikkelcadmiumbatterij)

Battery/Batterij (BP-90 type)

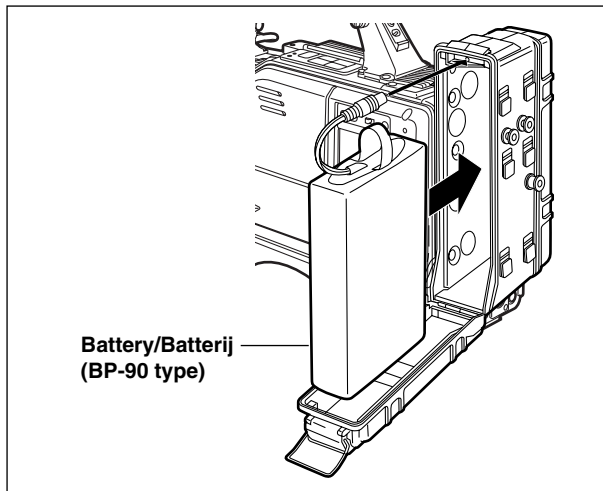

Anton Bauer Battery
Anton Bauer-Batterij

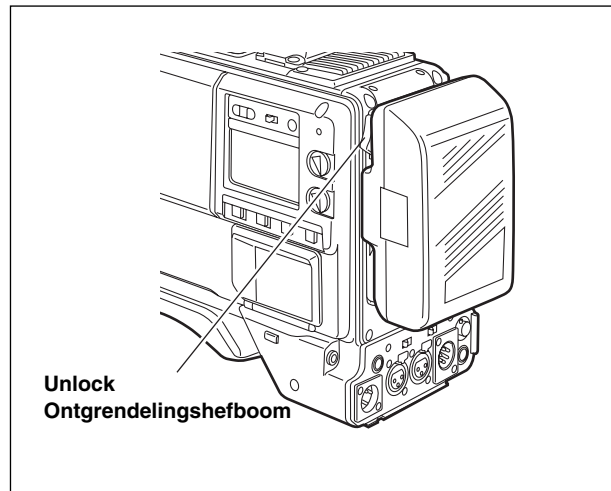

- If a battery made by any other manufacturer is to be used, check the Operating Instructions accompanying the battery.
- In geval u een batterij van een anden fabrikant zou gebruiken, gelieve dan eerst zorgvuldig de gebruiksaanwijzing van deze batterij te lezen.

Back-up Battery (Lithium Battery)

Batterij Voor Reservegeheugen (Lithiumbatterij)

- For the removal of the battery for disposal at the end of its service life, please consult your dealer.
- Raadpleeg uw leverancier over de verwijdering van de batterij op het moment dat u het apparaat bij einde levensduur afdankt.

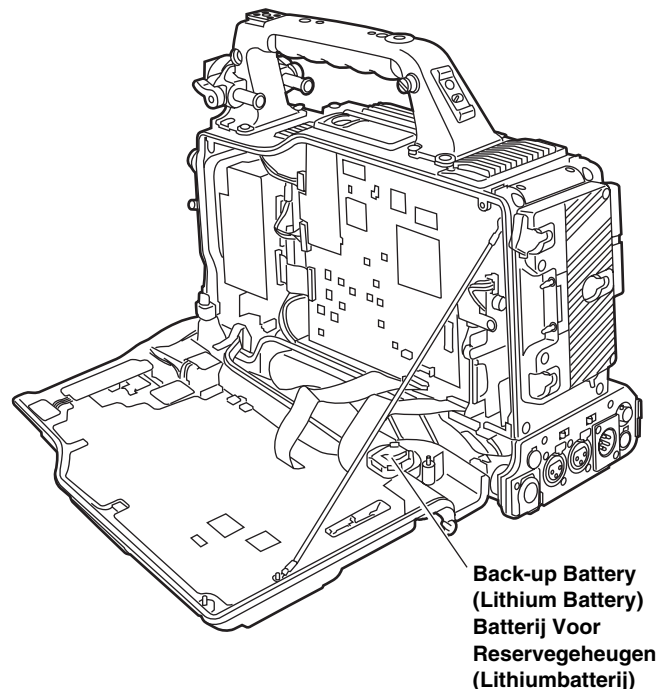

Contents

Chapter 1	General	6	4-5	Setting the time data	33
1-1	Features of the camera unit	6	4-5-1	Setting the user bits	33
1-2	Features of the VTR unit	7	4-5-2	Setting the internal clock's date and time	34
1-3	System configuration	8	4-5-3	Setting the time code	35
			4-5-4	Externally locking the time code	35
			4-5-5	Setting the UMID information	36
Chapter 2	Parts and their functions	9	4-6	Menu displays on the viewfinder screen	37
2-1	Power supply and accessory mounting section	9	4-6-1	Menu configuration	37
2-2	Audio function section	10	4-6-2	Basic menu operations	37
2-3	Shooting and recording/playback function section	12	4-6-3	Selecting the user menus	38
2-4	Menu operation section	15	4-7	Viewfinder screen status displays	39
2-5	Time code related section	16	4-7-1	Viewfinder lamp displays	39
2-6	Warning/status display section	17	4-7-2	Viewfinder screen status display configuration	39
2-7	Display window and its displays	17	4-7-3	Selecting the viewfinder screen display items	39
2-8	Viewfinder section	19	4-7-4	Display modes and setting changes/adjustment result messages	45
			4-7-5	Setting the marker displays	45
			4-7-6	Setting the camera ID	45
			4-7-7	Mode check screen displays (MODE CHECK button function)	46
			4-7-8	Marker check screen displays (MARKER SELECT button function)	46
			4-7-9	Checking the return video signal on the viewfinder	46
Chapter 3	Recording and playback	20	4-8	Menu-driven function setup	47
3-1	Cassette tapes	20	4-8-1	Setting the USER SW GAIN switching	47
3-2	Basic procedures	21	4-8-2	Selecting the video output signals	47
3-3	Scene-to-scene continuity	23	4-8-3	Selecting the F.AUDIO LEVEL control function	48
3-4	NEWS REC function SDC615	23	4-8-4	Allocating functions to the USER MAIN, USER1 and USER2 buttons	48
3-5	PRE-RECORDING function SDC905	24	4-8-5	Setting the color temperature manually	49
3-6	INTERVAL REC function	24	4-9	Data handling	49
3-7	RETAKE function	26	4-9-1	Handling the setup card	49
3-8	Rec-review function	26	4-9-2	Setup card operations	50
3-9	Normal playback and playback at different speeds	26	4-9-3	How to use the user data	53
			4-9-4	How to use the scene file data	54
			4-9-5	How to return the menus settings to the user standard settings	57
			4-9-6	How to return the menus settings to the factory standard settings	57
			4-9-7	How to use the lens file data	57
Chapter 4	Adjustments and settings for recording	27	Chapter 5	Preparation	58
4-1	Adjusting the white balance and black balance	27	5-1	Supplying the power	58
4-1-1	Adjusting the white balance	27	5-1-1	Attaching the battery and setting the battery type	58
4-1-2	Adjusting the black balance	29	5-1-2	Using an AC power supply	61
4-2	Setting the electronic shutter	30	5-2	Attaching the viewfinder and adjusting its position	61
4-2-1	Shutter modes	30	5-3	Attaching the lens and performing the flange back and white shading adjustments	62
4-2-2	Setting the shutter mode and speed	30			
4-2-3	Setting the synchro scan mode	31			
4-3	Selecting the recording signals and recording system	31			
4-3-1	Selecting the recording signals	31			
4-3-2	Selecting the recording system	32			
4-4	Selecting the audio input signals and adjusting their recording levels	32			
4-4-1	Selecting the audio input signals	32			
4-4-2	Adjusting the audio signal recording levels	32			

Contents

5-4 Audio input signal preparations	67	7-3-11 FLARE	89
5-4-1 When using the front microphone	67	7-3-12 CAMERA SETTING	90
5-4-2 When using an external microphone	67	7-4 VF	90
5-4-3 When using a wireless receiver	68	7-4-1 VF DISPLAYS	90
5-4-4 When using an audio component	68	7-4-2 VF MARKER	91
5-5 Mounting the unit on a tripod	69	7-4-3 USER BOX	91
5-6 Attaching the shoulder strap	69	7-4-4 VF INDICATOR1	91
5-7 Adjusting the position of the shoulder pad	69	7-4-5 VF INDICATOR2	92
5-8 Attaching the rain cover	70	7-4-6 MODE CHECK IND	92
5-9 Connecting the extension control unit (AJ-EC3E)	70	7-4-7 !LED	92
5-10 Attaching the FEONT AUDIO LEVEL control knob	70	7-5 OPERATION	93
Chapter 6 Maintenance and inspections	71	7-5-1 CAMERA ID	93
6-1 Inspections prior to shooting	71	7-5-2 SHUTTER SPEED	93
6-1-1 Preparation for inspections	71	7-5-3 SHUTTER SELECT	93
6-1-2 Inspecting the camera unit	71	7-5-4 USER SW	94
6-1-3 Inspecting the VTR unit	72	7-5-5 SW MODE	94
6-1-4 Self-diagnosis function	73	7-5-6 WHITE BALANCE MODE	95
6-2 Maintenance	74	7-5-7 USER SW GAIN	95
6-2-1 Condensation	74	7-5-8 IRIS	96
6-2-2 Head cleaning	74	7-6 FILE	96
6-2-3 Cleaning inside the viewfinder	74	7-6-1 CARD READ/WRITE	96
6-2-4 Phenomena inherent to CCD cameras	74	7-6-2 CARD R/W SELECT	96
6-2-5 Replacing the backup battery	74	7-6-3 LENS FILE	97
6-2-6 Connectors and signals	75	7-6-4 SCENE	97
6-3 Warning system	76	7-6-5 INITIALIZE	97
6-3-1 Warning description tables	76	7-7 MAINTENANCE	97
6-3-2 Error codes	78	7-7-1 SYSTEM CHECK	97
6-3-3 Emergency eject	79	7-7-2 DIAGNOSTIC	97
Chapter 7 Menu description tables	80	7-7-3 LENS ADJ	97
7-1 Menu configuration	80	7-7-4 BLACK SHADING	98
7-2 SYSTEM SETTING	81	7-7-5 WHITE SHADING	98
7-2-1 SYSTEM MODE	81	7-8 VTR MENU	98
7-2-2 OPTION MODE	82	7-8-1 VTR FUNCTION	98
7-2-3 REC FUNCTION	83	7-8-2 BATTERY/TYPE	99
7-2-4 OUTPUT SEL	84	7-8-3 BATTERY SETTING1	99
7-2-5 GENLOCK	84	7-8-4 BATTERY SETTING2	101
7-3 PAINT	85	7-8-5 MIC/AUDIO1	102
7-3-1 ROP	85	7-8-6 MIC/AUDIO2	103
7-3-2 MATRIX	85	7-8-7 TC/UB	103
7-3-3 COLOR CORRECTION	86	7-8-8 UMID SET/INFO	104
7-3-4 LOW SETTING	86	7-8-9 VTR DIAG	104
7-3-5 MID SETTING	87	7-9 OPTION MENU	105
7-3-6 HIGH SETTING	87	7-9-1 OPTION	105
7-3-7 ADDITIONAL DTL	88	Chapter 8 Specifications	106
7-3-8 SKIN TONE DTL	88		
7-3-9 KNEE/LEVEL	89		
7-3-10 GAMMA	89		

Chapter 1 General

The models AJ-SDC615 and AJ-SDC905 are camera recorders featuring three CCD image sensors which each have a 2/3-inch on-chip lens.

The AJ-SDC905 **SDC905** supports both the DVCPRO and DVCPRO50 formats. (The AJ-SDC615 **SDC615** supports only the DVCPRO format.)

Both camera recorders feature a compact size, light weight, low power consumption, high image quality, high sensitivity, excellent mobility and outstanding dust-proof and moisture-proof characteristics.

They are ideally suited not only for news gathering but also for a wide range of production applications.

Both their camera and VTR units employ digital signal processing technology to achieve an improved image quality and stability, and they configure a system which enables data management using setup cards.

An IEEE 1394 connector is provided as a standard feature for increased mobility.

1-1 Features of the camera unit

● 3 CCDs with a 2/3-inch on-chip lens

Aspect ratios of 16:9 and 4:3 are supported.

● Storage type high-sensitivity function

The unit comes with a storage type gain increase function. This is a function that makes it possible to achieve a higher sensitivity of up to 20 dB above the regular gain increase.

<Note>

Due to the properties inherent to the unit's CCD image sensors, the top left part of the screen may become slightly brighter when the cumulative gain is increased.

● Digital zoom function

The unit is equipped with a digital zoom employing function. This function is particularly useful when zooming further in on a subject.

● 12-bit A/D conversion digital signal processing circuitry

The analog images are processed into digital data by a 12-bit A/D converter with sampling frequencies of 18 MHz, and by operating the signal processor using the 36 MHz frequency, it is possible to reproduce images which are more finely detailed and achieve improvements in stability and reliability.

● 12-axis independent color correction function

Serving as a paint function, this facility enables the colors for 12 axes to be compensated for independently and is very useful for creating finely detailed images.

● Data control function

When the unit is used on its own, one set of user data and four sets of scene file data can be registered. Further, by using an SD card or a Multimedia Card (optional accessory) as the setup card, up to eight sets of setup data can be stored.

<Note>

SD card and MultiMedia card used in this unit do not comply with the SD standard. Do not use cards formatted using this unit with other camera-recorders. Further, NTFS and FAT32 formatted cards cannot be used with this unit.

The recommended size for SD cards is 8 MB or more and 4 MB or more for MultiMedia cards.

● MARKER SELECT button

At the front of the unit is a button for checking the information concerning the markers on the viewfinder screen. This is useful for checking the picture angle, for instance, during shooting.

● ECU supported

The unit supports the AJ-EC3E extension control unit.

● Single-action shoulder pad slide function

It is now possible to adjust the position where the unit is optimally balanced for operation using a single-touch action. This means that the operator can easily optimize the unit's balance when the lens, battery and other peripheral camera devices have been installed on the unit.

1-2 Features of the VTR unit

● DVCPRO and DVCPRO50 formats supported

SDC905

The VTR unit compresses the images using a component digital recording system that uses the latest compression technology, and for the sound it employs non-compression PCM recording with an excellent signal-to-noise ratio, frequency band, waveform characteristics and reproduction characteristics of the finely detailed areas. As a result, both the picture quality and sound quality are taken to new heights of excellence.

A choice of recording formats tailored to the application at hand is offered: the DVCPRO50 format when priority is required to be given to the picture quality, and the DVCPRO format when economy is to be given precedence.

● DVCPRO format supported SDC615

The VTR unit compresses the images using a component digital recording system that employs the latest compression technology, and for the sound it uses non-compression PCM recording with an excellent signal-to-noise ratio, frequency band, waveform characteristics and reproduction characteristics of the finely detailed areas. As a result, both the picture quality and sound quality are taken to new heights of excellence.

● Power-saving management function

In order to reduce its power consumption efficiently, the unit has a function that shuts down circuitry that is not required for the particular VTR mode established at the time. This enables the user to perform operations while conserving power.

● Pre-recording function featured SDC905

This function makes it possible to record the pictures and sound up to 6 seconds ahead of the point in time when recording is commenced by pressing the VTR START button or VTR button on the lens. It is effective in preventing shots from being missed.

● Interval REC function provided

This unit is capable of interval shooting.

The AJ-SDC905 SDC905 makes it possible to conduct recording in intervals with a minimum recording time in increments of one frame.

The AJ-SDC615 SDC615 makes it possible to conduct recording in intervals with a recording time of 2 seconds or more.

This is particularly useful for shooting science and nature programs.

Furthermore, when the unit is used for one-shot recording, frame-by-frame shooting is easily accomplished.

● NEWS REC function SDC615

This function especially supports shooting in the context of news gathering or documentary filming to ensure that shutter opportunities are not passed up.

By controlling the start key acknowledgment time, the unit can continuously record without the user having to interrupt the recording: this safeguards against the failure to record those precious moments—a failure that occurs when recording is resumed after it has been shut down temporarily.

● RETAKE function

This function is for not leaving behind superfluous cuts when a cut turns out to be no good during the shooting of news, reports or art programmes. By cutting down on the time taken for copying onto the work tape, for instance, this function is very effective in achieving economical operation. Users should remember to handle this function very carefully.

● Input signals of 2 separate audio channels supported

The unit enables the audio input signals in two channels to be selected separately. Further, the level of the signal in each channel can be monitored on the LCD display window.

● Front audio level control

The unit's front panel is equipped with a control for adjusting the audio recording level. This is useful when the user is filming on his or her own and the audio level needs to be adjusted. It also is possible to cancel the effect of this control.

● UniSlot® wireless receiver

The unit's construction supports a slot-in wireless receiver which is available as an optional accessory.

● Built-in DOLBY NR system

The CUE audio recording circuitry contains a Dolby B noise reduction circuit.

- Dolby noise reduction manufactured under license from Dolby Laboratories Licensing Corporation.
- "DOLBY" and the double-D symbol  are trademarks of Dolby Laboratories Licensing Corporation.

● Frame-to-frame continuity

Simply by pressing the VTR START button or VTR button on the lens, the continuity from one frame to the next is assured with a precision of +1 frame or less.

● Rec-review function

This automatically rewinds the tape for the last 2 to 10 seconds recorded and plays back the recording. This enables the recording to be monitored without delay.

Chapter 1 General

- **Built-in time code generator/reader**

This enables the time code information to be recorded on the dedicated sub-code track and played back.

- **Metadata supported**

The unit allows information from the AJ-GPS900G GPS unit to be recorded on tape as the metadata UMID information. This is useful when it comes to managing on-tape information.

- **DVCPRO (IEEE 1394 digital input/output) connector provided**

The unit is standard equipped with an input/output connector for signals complying with the IEEE 1394 standard.

This connector can be connected with an external unit using an IEEE 1394 cable.

1-3 System configuration

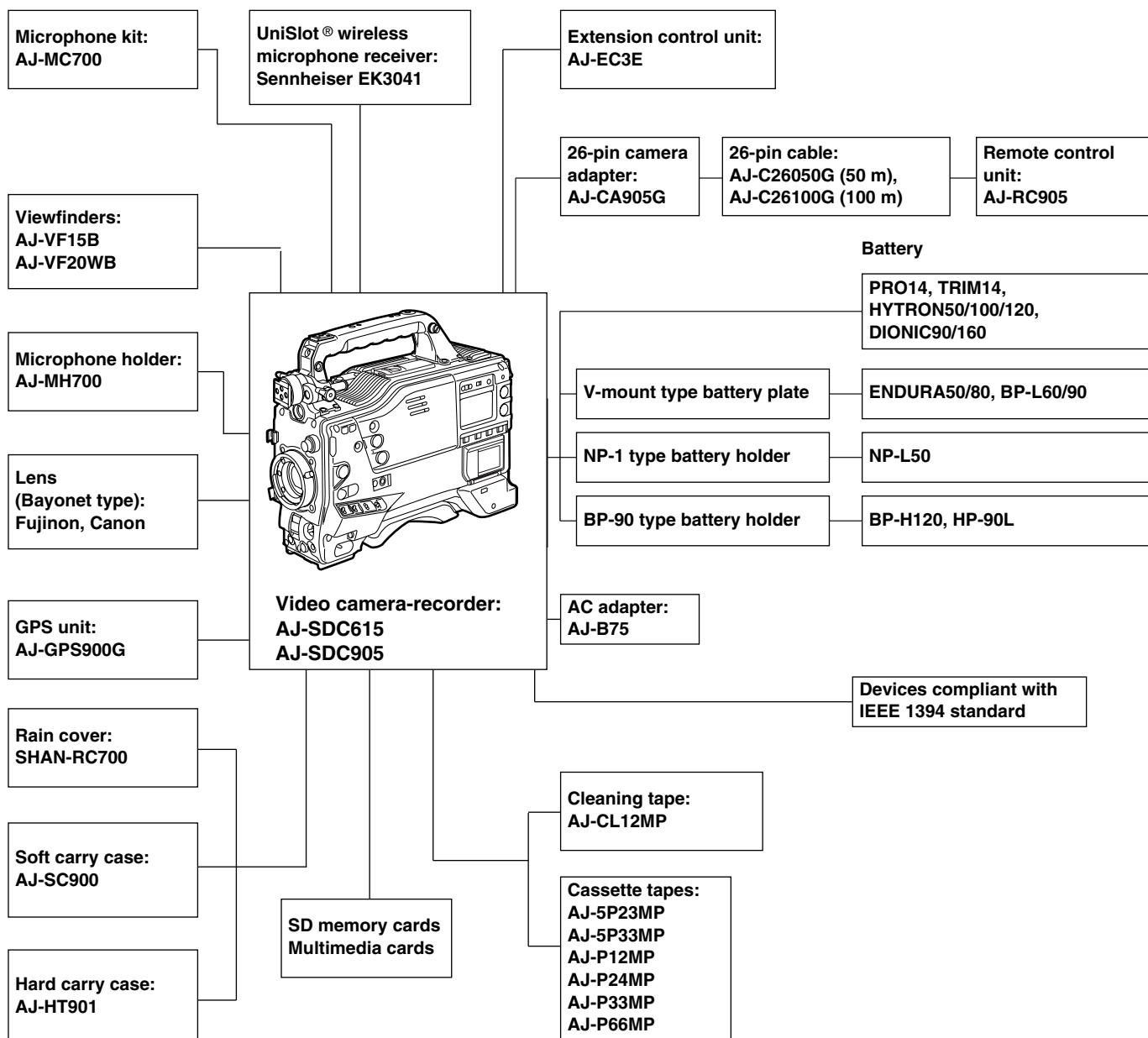

Chapter 2 Parts and their functions

2-1 Power supply and accessory mounting section

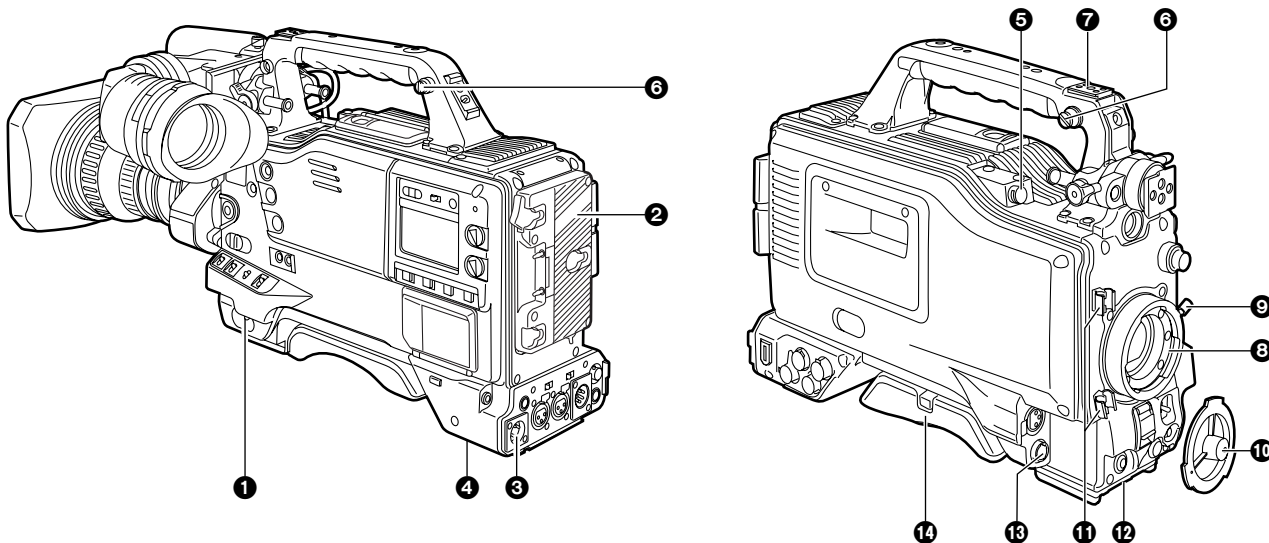

1 POWER switch

This switch turns the power ON and OFF.

2 Battery mount

This is for attaching the Anton Bauer battery pack.

3 DC IN (external power input) socket (XLR, 4-pin)

When operating this unit using an AC power source, this socket is connected to the model AJ-B75 AC adapter (optional accessory).

4 BREAKER switch

If an excessively high current flows inside the unit due to some problem or other, the circuit breaker is tripped and the power is automatically turned off to protect the unit. Push this button in after an inspection has been conducted or repairs performed inside the unit by a qualified service person. If there are no problems, the power will come back on.

5 GPS connector

The connector from AJ-GPS900G, a GPS unit available as an optional accessory, is connected here.

6 Shoulder belt fittings

The shoulder belt is attached here.

7 Light shoe

Use this to attach the video light, etc.

8 Lens mount (bayonet type)

The lens is attached to this mount.

9 Lens lever

This lever is tightened to secure the lens after it has been attached to the lens mount.

10 Lens mount cap

To remove the cap, push the lens lever 9 up. Keep the cap in place while the lens is not attached.

11 Lens cable/microphone cable clamp

This clamp is for anchoring the lens cable or microphone cable.

12 Tripod mount

Mount the tripod attachment (SHAN-TM700), available as an optional accessory, when the unit is to be anchored to a tripod.

13 LENS jack (12-pin)

The connecting cord of the lens is connected to this jack. For further details on the lenses that can be used, refer to the operating instructions of the lenses concerned.

14 Easy-to-adjust shoulder pad

The position of the shoulder pad can be adjusted backward or forward so that the unit is balanced when it is carried on the user's shoulder.

Chapter 2 Parts and their functions

2-2 Audio function section (input system)

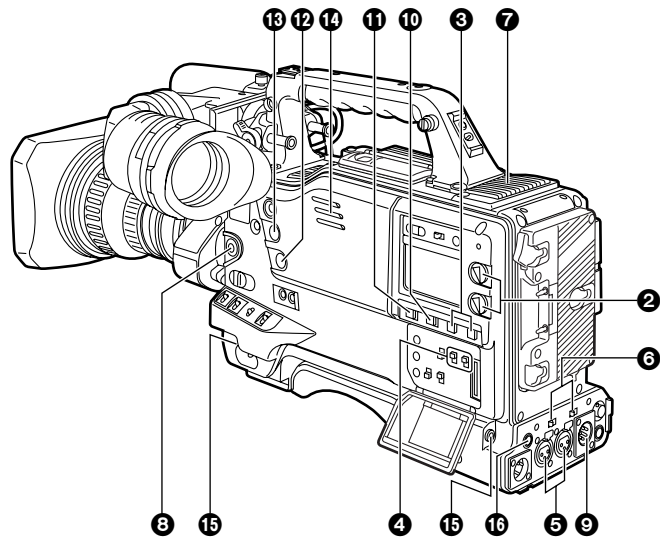
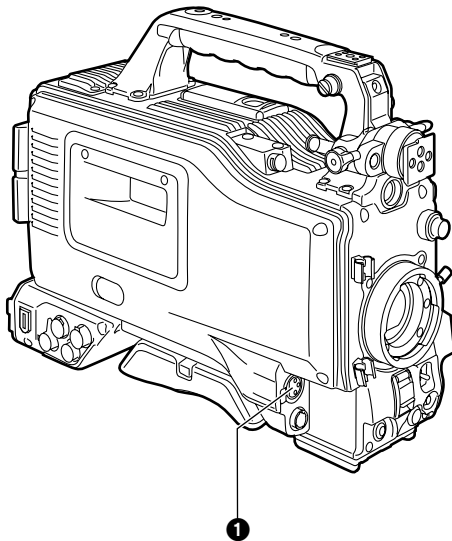

① MIC IN (microphone input) jack (XLR, 3-pin)

Connect the microphone (optional accessory) here. The power for the microphone is supplied from this jack.

② AUDIO LEVEL CH1/CH2 (audio channel 1 & 2 recording level adjustment) controls

When the AUDIO SELECT CH1/CH2 switch ③ is set to MAN, the recording level of audio channels 1 and 2 can be adjusted using these controls.

The controls come with a locking mechanism. Therefore, to adjust the recording level, simultaneously push in and turn the controls.

③ AUDIO SELECT CH1/CH2 (audio channel 1 & 2 automatic/manual level adjustment selector) switch

This is used to select the method for adjusting the recording levels of audio channels 1 and 2.

AUTO : Set here for automatic adjustment.

MAN : Set here for manual adjustment.

④ AUDIO IN (audio input selector) switch

These are used to select the input signals to be recorded on audio channels 1 and 2.

FRONT :

The input signals supplied from the microphone which has been connected to the MIC IN jack ① are recorded.

W.L. (wireless) :

The input signals from the slot-in wireless microphone receiver are recorded.

REAR :

The audio input signals supplied from the audio component which has been connected to the AUDIO IN CH1/CH2 connectors ⑤ are recorded.

The mixed signals of audio channels 1 and 2 are output to the remote control unit (AJ-RC905).
The signals are output now as is without the adjustment of their level, etc.

⑤ AUDIO IN CH1/CH2 (audio input channel 1 & 2) connectors (XLR, 3-pin)

An audio component or microphones are connected here.

⑥ LINE/MIC/+48V (line input/mic input/mic input + 48V) selector switch

This is used to switch the audio input signals from the audio component which has been connected to the AUDIO IN CH1/CH2 connectors ⑤.

LINE : The audio input signals from the audio component serving as the line input are selected.

MIC : The audio input signals from the internal power supply type of microphone are selected. (The phantom mic power is not supplied from the unit.)

+48V : The audio input signals from the external power supply type of microphone are selected. (The phantom mic power is supplied from the unit.)

⑦ Wireless receiver slot

The UniSlot[®] wireless receiver (optional accessory) can be attached here.

⑧ FRONT AUDIO LEVEL (audio recording level adjustment) control

This enables the recording level of audio channels 1 and 2 to be adjusted. This level can be adjusted regardless of the setting position of the AUDIO SELECT switch.

When the <MIC/AUDIO1> screen is opened from the VTR MENU page by performing a menu operation, whether to enable or disable the operation of this level control can be set using the FRONT VR CH1 and FRONT VR CH2 setting items.

SDC905

- The same signals as for CH1 are recorded on audio track CH3. Similarly, the same signals as for CH2 are recorded on audio track CH4.
- The signals are recorded on two channels (CH1 and CH2) when the DVCPRO format (25 Mbps) is set.

2-2 Audio function section (output system)

9 AUDIO OUT connector (XLR, 5-pin)

The audio signals recorded on audio channels 1 and 2 or audio channels 3 and 4 are output from this connector. With the AJ-SDC905 **SDC905**, the signals to be output can be selected using the MONITOR SELECT CH1/2 • CH3/4 selector switch.

10 SDC905 MONITOR SELECT (audio channel) CH1/2 • CH3/4 selector switch

This is used to select the audio channels whose signals are to be output to the speaker, earphone and AUDIO OUT connector.

CH1/2 : The signals of audio channels 1 and 2 are output.

CH3/4 : The signals of audio channels 3 and 4 are output.

In addition, the channel indications for the audio level meters appearing in the display window and viewfinder change when this switch is operated.

SDC615 MONITOR SELECT (stereo/mix) ST • MIX selector switch

This is used to select the sound which is to be output to the speaker, earphone and AUDIO OUT connector.

ST: The stereo audio signals of channels 1 and 2 are output.

MIX: The mixed audio signals of channels 1 and 2 are output.

11 SDC905 MONITOR SELECT (audio selection) CH1/3 • ST • CH2/4 selector switch

This is linked with the MONITOR SELECT CH1/2 • CH3/4 selector switch and used to select the sound which is to be output from the speaker, earphone and AUDIO OUT connector.

CH1/3 : The signals of audio channel 1 or 3 are output.

ST : The stereo audio signals of either audio channels 1 and 2 or audio channels 3 and 4 are output. Using a menu setting, the stereo signals can be changed to MIX signals.

CH2/4 : The signals of audio channel 2 or 4 are output.

	MONITOR SELECT CH1/2 • CH3/4 selector switch	
	CH1/2	CH3/4
CH1/3	Audio channel 1	Audio channel 3
ST	Stereo* signals of audio channels 1 and 2	Stereo* signals of audio channels 3 and 4
CH2/4	Audio channel 2	Audio channel 4

* Either STEREO or MIX can be selected as the setting for the MONITOR SELECT item by opening the <MIC/AUDIO2> screen from the VTR MENU page by performing a menu operation.

SDC615 MONITOR SELECT (audio selection) CH1 • 1/2 • CH2 selector switch

This is linked with the MONITOR SELECT ST • MIX selector switch and used to select the sound which is to be output from the speaker, earphone and AUDIO OUT connector.

CH1: The signals of audio channel 1 are output.

1/2: The stereo audio signals of audio channels 1 and 2 are output. The stereo signals can be changed into mixed signals using the MONITOR SELECT ST • MIX selector switch.

CH2: The signals of audio channel 2 are output.

	MONITOR SELECT ST • MIX selector switch	
	ST	MIX
CH1	Audio channel 1	Audio channel 1
1/2	Stereo signals of audio channels 1 and 2	Mixed signals of audio channels 1 and 2
CH2	Audio channel 2	Audio channel 2

12 MONITOR (volume) control

This is used to adjust the volume of the monitor speaker or earphone.

13 ALARM (warning alarm volume adjustment)

This is used to adjust the volume of the warning alarms from the earphones which have been connected to the speaker **14** or PHONES jack **15**.

The warning alarms are not audible when this control is at its lowest setting.

14 Speaker

The EE sound during recording or the playback sound during playback can be monitored through this speaker.

The warning alarms are output in synchronization with the flashing or lighting of the warning lamps and warning displays.

The sound heard from the speaker is automatically cut off when earphones are connected to the PHONES jack **15**.

15 PHONES (earphones) jack (mini jack)

This is the earphone (stereo) jack which is used to monitor the audio signals. When earphones are connected, the sound from the speaker is automatically cut off. The sound which is output from the two jacks (front and rear) is the same.

16 DC OUT (DC power supply) output socket

This normally serves as the DC 12 V output socket. A current of approximately 1 A can be supplied.

Chapter 2 Parts and their functions

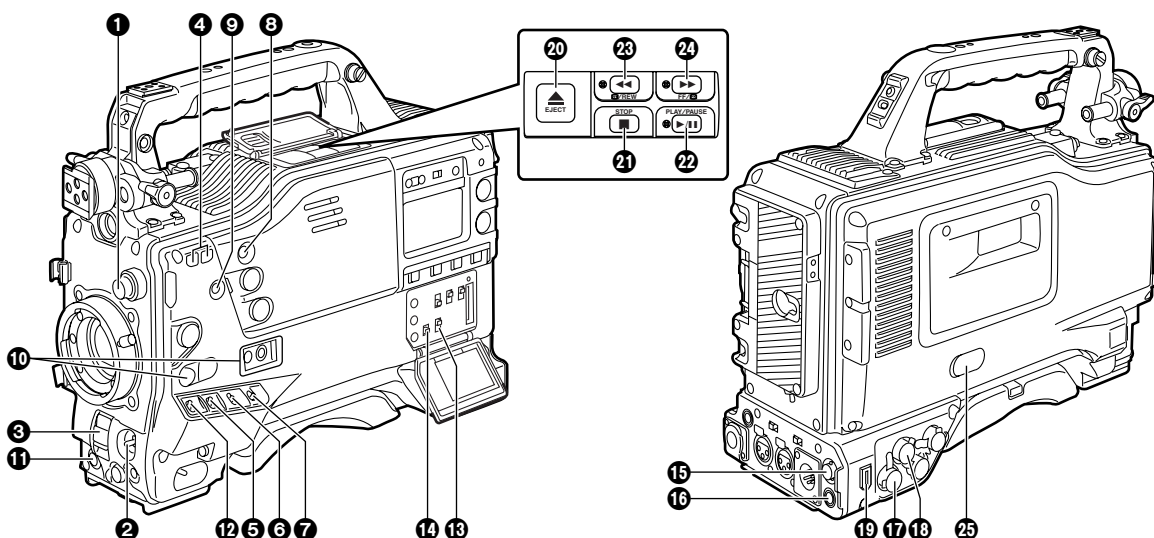

2-3 Shooting and recording/playback function section

Shooting and recording (camera unit)

1 FILTER (filter switching) controls

These are used to select the filter in accordance with the subject's brightness and color temperature.

- 1: 3200 K (transparent) 2: 5600 K+1/8 ND
- 3: 5600 K 4: 5600 K+1/64 ND

Examples of filter selection

Shooting conditions	Filter
Sunrise, sunset, inside a studio	1 (3200 K)
Outdoors under a clear sky	2 (5600 K+1/8 ND) or 4 (5600 K+1/64 ND)
Outdoors under cloudy or rainy skies	3 (5600 K)
Snowscapes, high mountains, seashores or other perfectly clear scenery	4 (5600 K+1/64 ND)

2 AUTO W/B (white/black) BAL switch

AWB: The white balance is automatically adjusted. When the AWB memory selector switch on the side panel is set to A or B and then the AUTO W/B BAL switch is operated, the adjustment value is recorded in the memory. When VAR has been selected as the setting for AWB A and/or AWB B menus, the value will be the one set in the menu and this switch will not function. Note that this switch will also not function at the PRST position.

ABB: The black balance is automatically adjusted. If the AUTO W/B BAL switch is held down at the ABB position for 5 or more seconds, the black shading is compensated automatically.

<Note>

When white balance or black balance are being automatically adjusted and the switch is pressed again to either the AWB side or to the ABB side, the automatic adjustment for the side pressed will be stopped. The adjusted value in this case is the value before automatic adjustment was performed.

3 SHUTTER switch

This is the ON/OFF selector switch of the electronic shutter.

OFF : The electronic shutter does not operate.

ON : The electronic shutter operates.

SEL : This is used when the electronic shutter speed is to be changed.

The switch is a non-locking type. The shutter speed changes each time it is operated. For further details, refer to "4-2 Setting the electronic shutter."

4 Synchro scan adjustment switches

These switches become effective when the shutter switch 3 is set to ON and SYNCHRO SCAN is selected. They are used to adjust the synchro scan speed.

When the "-" switch is pressed, the shutter speed is reduced; conversely, when the "+" switch is pressed, it is increased.

During personal computer monitor shooting, etc. adjust these switches to the positions where the horizontal bar noise inside the viewfinder is decreased.

5 GAIN selector switch

This is used to select the gain of the video amplifier in accordance with the lighting conditions prevailing at the time of the shooting. The gain values for the L, M and H settings are set ahead of time on the setting menu. Their factory settings are 0 dB, 9 dB and 18 dB, respectively.

6 OUTPUT/AUTO KNEE selector switch

This switch selects the video signals which are to be output from the camera unit to the VTR unit, viewfinder and/or video monitor.

CAM. AUTO KNEE ON:

The images shot by the camera are output. The AUTO KNEE circuit operates.

CAM. AUTO KNEE OFF:

The images shot by the camera are output. The MANUAL KNEE circuit operates.

BARS:

Color bar signals are output. The AUTO KNEE circuit does not operate.

AUTO KNEE function

When shooting with the level set to people or scenes against a high-brightness background, the background will be whitened out, and the buildings and scene in the background will be blurred. If the AUTO KNEE function is activated at times like this, the background will be reproduced clearly. This function is effective for shooting in the following situations:

- When shooting people in the shade under a clear sky
- When simultaneously shooting people in a car or indoors and the outside scenery through a window
- When shooting scenes with a strong contrast

7 WHITE BAL (white balance memory selector) switch

This is used to select the method used to adjust the white balance.

PRST:

Set the switch to this position at times when, for instance, there is no time to adjust the white balance. The factory setting for the white balance is 3200K, but this can be changed to any other value by a menu setting. For details, refer to “4-8-5 Setting the color temperature manually.”

A or B:

When the AUTO W/B BAL switch 2 is set to AWB, the white balance is automatically adjusted, and the adjusted value is stored in memory A or memory B. For details, refer to “4-1-1 Adjusting the white balance.”

As the factory setting, the settings are to be allocated to the memory. Using a menu setting, it is also possible to allocate the setting for the auto tracking white balance (ATW) performed with the automatic tracking system to memory B or allocate the color temperatures of the user's choice to memory A and memory B. For details, refer to “4-8-5 Setting the color temperature manually.”

8 MODE CHECK button

Each time this button is pressed, one of the four screen pages (STATUS screen display, !LED screen display, FUNCTION screen display and AUDIO screen display) is selected and displayed on the viewfinder to indicate the camera's settings.

This does not affect the output signals of the camera.

9 MARKER SELECT button

This is used to select the marker information displays on the viewfinder screen. Each time it is pressed, the two marker information display screens set by the menu are switched in the following sequence: A (A marker display) → B (B marker display) → OFF (no marker display) → A, and so on repeatedly. Note that when the power is switched ON, the display on the viewfinder screen immediately before the power was switched OFF will appear. For details, refer to “4-7-8 Marker check screen displays.”

10 USER MAIN, USER 1 and USER 2 buttons

A user setting can be allocated to each of these buttons using the setting menu. When a button is pressed, the user setting mode allocated to it is selected.

When the button is pressed again, the selected mode is released.

For details, refer to “4-8-4 Allocating functions to the USER MAIN, USER1 and USER2 buttons.”

Shooting and recording (VTR unit)

11 VTR START/STOP button

When this is pressed, recording starts; when it is pressed again, recording stops. This button functions in the same way as the lens VTR button.

12 VTR SAVE/STBY (tape protection) switch

This is used to select the power supply mode when the VTR has temporarily stopped recording (REC PAUSE mode).

SAVE: This is the tape protection mode. The cylinder is stopped in the half-loading status.

Less power is consumed than at the STBY position, and the operating time provided by the battery is prolonged. Compared with the STBY position, it takes longer for recording to commence after the VTR START button 11 has been pressed. When the switch is set to this position, the VTR SAVE lamp inside the viewfinder lights.

STBY: At this position, recording is commenced as soon as the VTR START button is pressed.

<Note>

When the prescribed amount of time has elapsed in the STBY mode, the unit is automatically set to the SAVE mode. To return the unit to the STBY mode, set the VTR SAVE/STBY switch to SAVE, and then again to the STBY position.

Chapter 2 Parts and their functions

13 OUTPUT SEL (output signal selection) switch

This is used to select the signals output from the VIDEO OUT connector and MON OUT connector.

VTR : In the recording or other EE mode, the camera images are output from the connectors; in the playback or other VV mode, it is the VTR's playback signals which are output.

CAM : The camera images are output at all times.

OFF : The video output is stopped and the power reduction mode is established.

Furthermore, the audio output signals are synchronized with the video signals as well.

For details on the video output, refer to "4-8-2 Selecting the video output signals."

<Notes>

- During recording, the output signals are not switched even when the position of this switch is changed. They are switched when the recording operation is stopped.
- When the signals input to the GENLOCK IN connector or DVCPRO connector are selected as the signals to be recorded, the switch setting will be the same as at the VTR position even if the switch is set at the CAM position.

14 VIDEO OUT CHARACTER switch

This is used to control the superimposing of the characters onto the images which are output from the VIDEO OUT connector.

ON : The characters are superimposed onto the images.

OFF : The characters are not superimposed onto the images.

For details on the character types, refer to "4-8-2 Selecting the video output signals."

15 VIDEO OUT (video signal output) connector

This is the video signal output connector. The video signals linked to the setting of the OUTPUT SEL switch are output from here.

16 ECU REMOTE (remote control) connector

The AJ-EC3E extension control unit (optional accessory) is connected here.

17 MON OUT (monitor output) connector

This is the connector for outputting the video signal which is used for monitoring. The video signals linked to the setting of the OUTPUT SEL switch are output from here. Whether characters are to be superimposed onto the images output from the VIDEO OUT connector can be selected separately using the internal menu.

For details, refer to "4-8-2 Selecting the video output signals."

18 GENLOCK IN connector

The reference signal is input to this connector when genlock is to be established with the camera unit or when the time code is to be externally locked. This signal can also be used as the return signal.

The connector serves as a video input connector for receiving the video signals from an external unit when the <SYSTEM MODE> screen is opened from the SYSTEM SETTING page by performing menu operations and VIDEO is selected as the REC SIGNAL menu item setting.

<Note>

A standard VBS signal (a composite signal including a burst signal) should be supplied as the input reference signal.

19 DVCPRO connector (6-pin)

This is the input/output connector for signals which comply with the IEEE 1394 standard. It can be connected with an external unit using an IEEE 1394 cable.

<Notes>

- Power is not supplied from the unit.
- Before proceeding to connect or disconnect the DV cable (IEEE1394), be absolutely sure to turn off the power of the units that are to be connected or disconnected using this cable.
- Before proceeding to connect the unit which uses a 6-pin type of DV connector, carefully check the shape of the connectors on the DV cable and unit. Connecting a connector upside down may damage the parts inside the camera-recorder and cause malfunctioning.

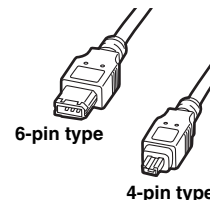

Always connect the DV cable to the unit with the 6-pin type DV connector first.

- When recording signals from an external unit, first check that video signals are supplied.
- While signals from an external unit are being recorded, do not operate the external unit or disconnect any of its cables. This will stop the output, which may result in the signals not being recognized when recording is resumed.
- You can connect a digital video unit equipped with a DV connector and digitally transfer video and audio signals as well as time codes and other information.
- When a DV cable has been connected to the DV connector, do not apply any strong external force as this may damage the connector.

20 EJECT button

This is pressed to insert or eject the cassette.

21 STOP button

This is pressed to stop the tape travel.

Chapter 2 Parts and their functions

22 PLAY/PAUSE button

This is pressed to view the playback picture on the viewfinder screen or using a color video monitor. The button's lamp comes on during playback.

When it is pressed during playback, the unit is set to pause in the playback mode (PLAY PAUSE), and the button's lamp flashes. If the unit is left in the pause mode for two minutes, it automatically changes to the stop (STOP) mode.

23 REW (rewind) button and lamp

When this button is pressed during stop, the tape is reviewed at high speed. Its lamp lights at this time.

When it is pressed during playback or pause, the tape is reviewed at approximately 4 times the normal tape speed. Both the PLAY lamp and REW lamp light at this time.

24 FF (fast forward) button and lamp

When this button is pressed during stop, the tape is cued at high speed. Its lamp lights at this time.

When it is pressed during playback or pause, the tape is cued at approximately 4 times the normal tape speed. Both the PLAY lamp and FF lamp light at this time.

25 EMERGENCY screw (inside rubber cap)

If the cassette does not eject even when the EJECT button is pressed, use a screwdriver or similar implement to push and turn the EMERGENCY screw at the same time: this will cause the cassette to be ejected.

For details, refer to "6-3-3 Emergency eject."

2-4 Menu operation section

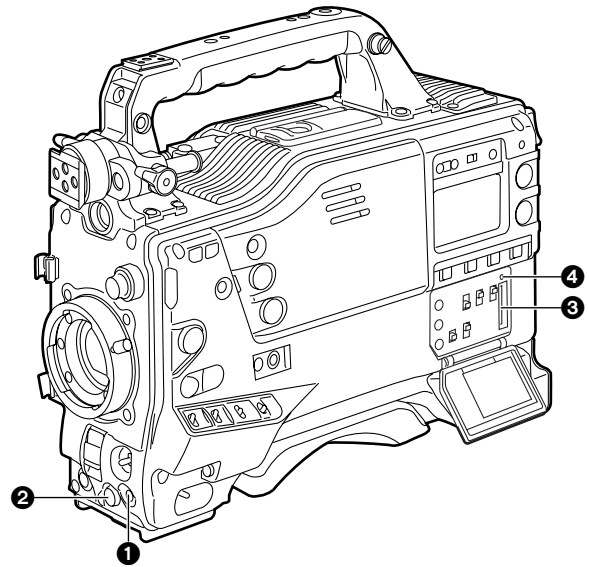

1 MENU button

This is used to switch the menu ON and OFF.

2 JOG dial button

This is used to select the menu items and perform settings when the MENU button 1 is at the ON position.

3 Setup card insertion slot

This is where the SD card (optional accessory) or Multimedia card (optional accessory) is inserted into the unit.

4 BUSY (operation mode display) lamp

This lamp shows the operation mode of the setup card. It lights during operation.

<Note>

When this lamp is lighted, refrain from inserting or removing the card.

Chapter 2 Parts and their functions

2-5 Time code related section

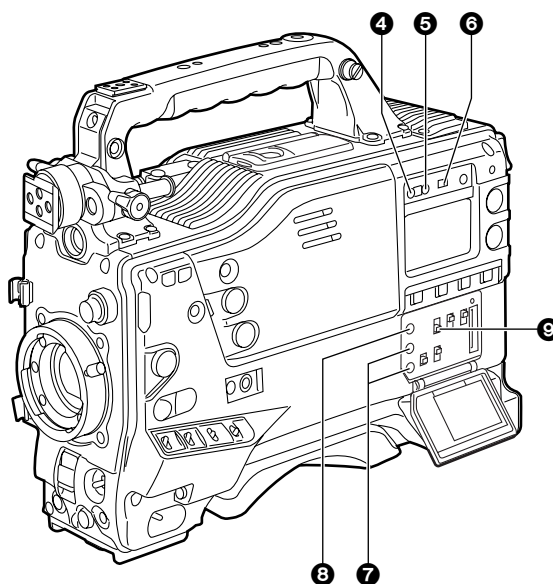
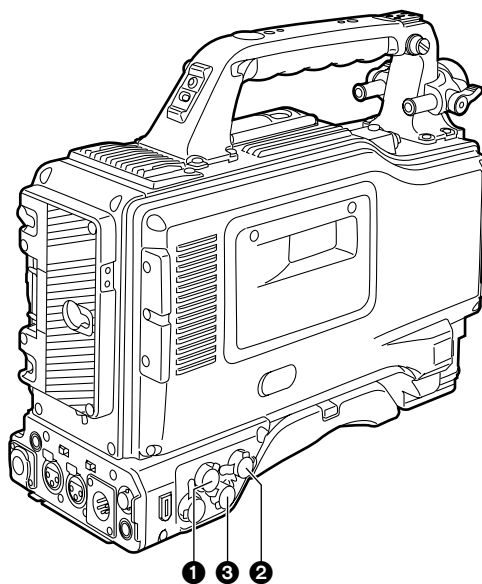

1 GENLOCK IN connector (BNC)

The reference signal is input to this connector when genlock is to be established with the camera unit or when the time code is to be externally locked.

2 TC IN connector (BNC)

Supply the time code which will serve as the reference to this connector when externally locking the time code.

3 TC OUT connector (BNC)

To lock the time code of an external VTR to the unit's time code, connect this connector to the time code input (TC IN) connector on the external VTR.

4 HOLD button

The time data display of the counter display section which was on the screen at the moment when this button is pressed is held. (However, the time code generator keeps running.) When the button is pressed again, the hold status is released.

It is used, for instance, to find out the time code or CTL counter value at which a particular scene was shot.

5 RESET button

This is used to reset the time data on the counter display section to "00:00:00:00." If it is pressed while the TCG switch 9 is at the SET position, the time code data and user bits data are respectively reset to "00:00:00:00."

6 DISPLAY switch

This is used to display the time code, CTL or user bits on the counter display section depending on the setting positions of this switch and the TCG switch 9.

UB : The user bits are displayed.

TC : The time code is displayed.

CTL : CTL is displayed.

7 "+" button, "-" button

These are used to increment or decrement by 1 the figure in the digit which was made to flash by the SHIFT button 8 when the time code or user bits are to be set.

8 SHIFT button

This causes the digit to be set to flash when the time code or user bits are to be set.

9 TCG (time code selector) switch

This is used to set the running mode of the built-in time code generator.

F-RUN : Set here to have the time code run all the time regardless of the VTR's operation.

This position is used to align the time code with the time or externally lock the time code.

SET : Set here when the time code or user bits are to be set.

R-RUN : Set here to have the time code run only during recording. The time code on the tape with scene-to-scene continuity is recorded continuously.

2-6 Warning/status display section

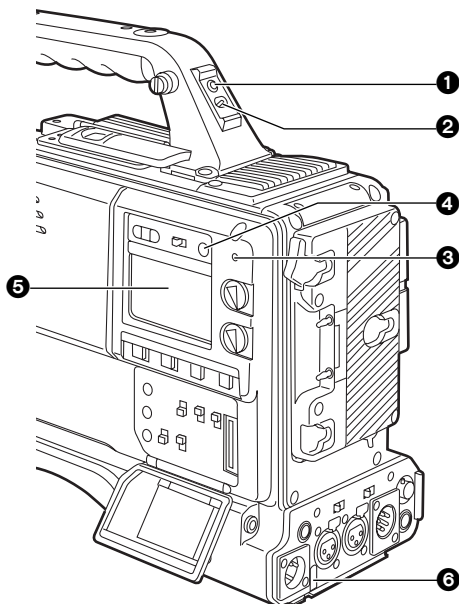

- 1 Back tally lamp**
When the back tally switch **2** is set to ON, this lamp serves the same function as the front tally lamp in the viewfinder.
- 2 Back tally switch**
This is used to control the unit's back tally lamp **1** and rear tally lamp **6**.
ON : The back tally lamp and rear tally lamp operate.
OFF : The back tally lamp and rear tally lamp do not operate.
- 3 WARNING lamp**
When a problem of some form or other occurs within the VTR unit, this lamp flashes or lights.
- 4 LIGHT switch**
This controls the lighting of the display window.
Each time it is pressed, the lighting of the display window **5** is set in turn from on to off or vice versa.
- 5 Display window**
This displays the alarms, remaining battery charge, audio levels, time data, etc. relating to the VTR unit.
- 6 Rear TALLY lamp**
When the back tally switch **2** is set to ON, this lamp operates in exactly the same way as the back tally lamp.

2-7 Display window and its displays

Remaining tape and remaining battery charge and audio channel level displays

Remaining tape display
The remaining tape time is displayed using 7 segments. The remaining tape time indicated by each segment is set to 3 minutes or 5 minutes using TAPE REMAIN/■ on the VTR MENU "BATTERY/TAPE" screen. Each time the number of minutes set for the segments elapses, one segment is cleared.

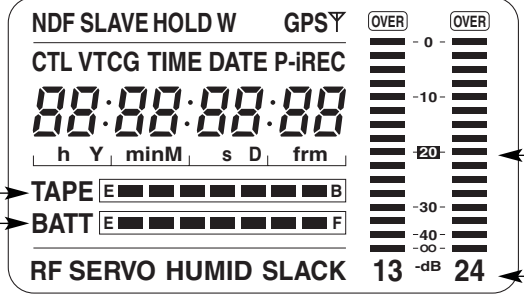

Remaining battery charge display
If a battery with a digital display (% display) is used, all 7 segments up to the "F" position light when the 70% or more of the battery charge remains.
When there is less than 70% of the battery charge remaining, the segments go out one by one in sequence every time the remaining charge drops by 10%. It is also possible to set all 7 segments to light at a 100% battery charge by selecting 100% as the setting for BATT REMAIN FULL on the <BATTERY/TAPE> screen of the VTR menu.

Audio channel level meter
SDC905 When the MONITOR SELECT CH1/2 • CH3/4 switch is set to CH1/2, numbers 1 and 2 indicating the audio channels appear, and the CH1 and CH2 audio levels are displayed. Conversely, when it is set to CH3/4, numbers 3 and 4 indicating the audio channels appear, and the CH3 and CH4 audio levels are displayed.

Displays relating to the VTR unit's operations and modes

Error code display
(for details, refer to "6-3 Warning system")

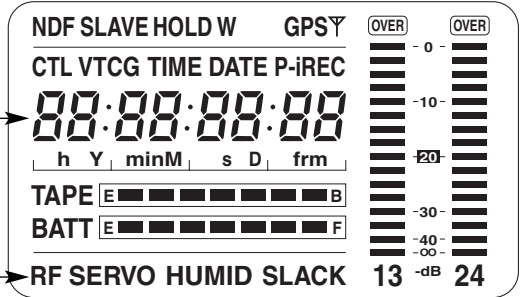

Warning displays
RF: Clogged video head
SERVO: Servo disturbance
HUMID: Formation of condensation on the head drum
SLACK: Problem in tape take-up
 For details, refer to "6-3 Warning system."

Chapter 2 Parts and their functions

Mode displays

- W:** Lights when the 16:9 aspect ratio mode is established.
- GPS:** Lights when signals cannot be received during GPS operation.
- GPS** Υ : Lights when signals are being received during GPS operation.
- P-REC:** Lights in pre-recording mode and flashes during the time set for pre-recording after the tally lamp for recording has turned off.
- iREC:** Lights during recording when the interval recording mode is established; flashes during recording standby.
- i:** Flashes when the interval recording mode has been selected.

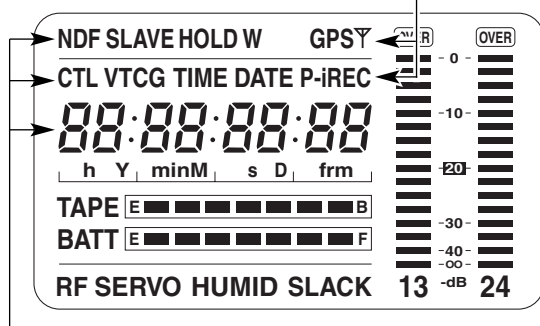

Displays relating to the time code

- SLAVE:** Lights when the time code is locked externally.
- HOLD:** Lights when the time generator/reader value is being held.
- CTL:** Lights when CTL is selected by the DISPLAY switch and the CTL count value is displayed.
- TCG:** Lights when TC (or UB) is selected by the DISPLAY switch and the TC (or UB) generator value is displayed.
- TC:** Lights when TC (or UB) is selected by the DISPLAY switch and the TC (or UB) reader value is displayed.
- VTCG:** Lights when UB is selected by the DISPLAY switch and the VIUB generator value is displayed.
- VTC:** Lights when UB is selected by the DISPLAY switch and the VIUB reader value is displayed.
- TIME:** Lights when UB is selected by the DISPLAY switch and the values of the hour, minutes and seconds in real time are displayed.
- DATE:** Lights when UB is selected by the DISPLAY switch and the values of the year, month and day are displayed in real time.
- No display:** Remains off when UB is selected by the DISPLAY switch and the real-time values of the hour and minutes in the time zone are displayed.
- Time counter display:**
The time code, CTL, user bits and real time are displayed.

<Note>

When UB has been selected by the DISPLAY switch, each time the HOLD button is pressed, the setting is switched in the following sequence: VTCG (VTC) → DATE → TIME → no display (time zone) → TCG (TC) and so on repeatedly.

Time code-related switch settings and display items

TCG switch position	DISPLAY switch position	Display item
SET	TC or CTL	Time code
	UB	User bits
F-RUN or R-RUN	CTL	CTL
	TC	Time code
	UB	User bits

2-8 Viewfinder section

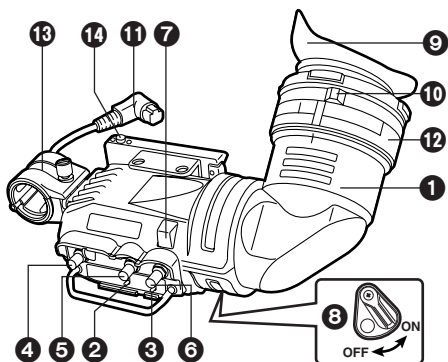

1 Viewfinder (optional accessory)

While recording or playback is underway, pictures can be viewed through the viewfinder in black and white. The warning displays concerning the unit's operation statuses and settings, messages, zebra patterns and markers (safety zone markers and center marker) can also be seen in the viewfinder.

2 ZEBRA (zebra pattern) switch

This is used to display the zebra pattern in the viewfinder.
ON : The zebra pattern is displayed.
OFF : The zebra pattern is not displayed.

3 TALLY switch

This is used to control the front tally lamp **7**.
HIGH: The brightness of the front tally lamp is increased.
OFF : The front tally lamp is turned off.
LOW : The brightness of the front tally lamp is reduced.

4 PEAKING control

This is used to adjust the outlines of the images seen inside the viewfinder to make focusing easier. Its adjustment does not affect the output signals of the camera.

5 CONTRAST control

This is used to adjust the contrast of the picture seen inside the viewfinder. Its adjustment does not affect the output signals of the camera.

6 BRIGHT control

This is used to adjust the brightness of the picture seen inside the viewfinder. Its adjustment does not affect the output signals of the camera.

7 Front tally lamp

This lamp is activated when the TALLY switch **3** is set to the HIGH or LOW position, and it lights while the VTR unit is recording. It also flashes to provide a warning display like the REC lamp inside the viewfinder. The lamp's brightness (HIGH or LOW) when it is lighted can be selected using the TALLY switch.

8 Back tally lamp

This lamp lights while the VTR unit is recording. It also flashes to provide a warning display like the REC lamp inside the viewfinder.
 When the lever is set to OFF, the back tally lamp is hidden.

9 Eyepiece

10 Diopter adjustment ring

This is adjusted in line with the camera operator's diopter in such a way that the user can see the image on the viewfinder screen most clearly.

11 Connecting plug

12 Locking ring

13 Microphone holder

14 Viewfinder stopper

This is used to attach and remove the viewfinder.

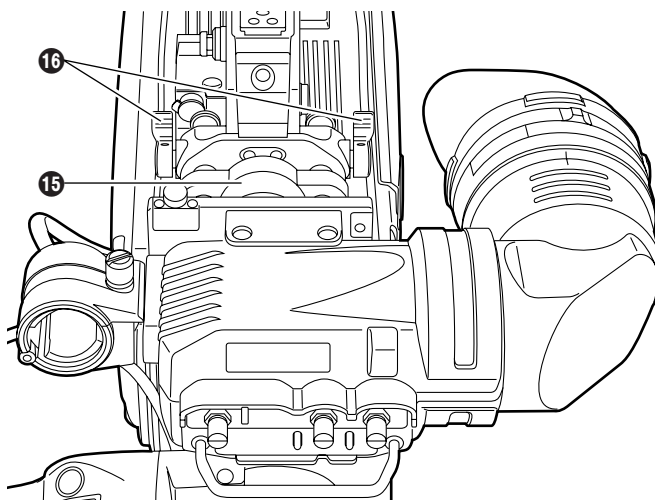

15 Viewfinder left-right position anchoring ring

This is used to adjust the left-right position of the viewfinder.

16 Viewfinder front-back position anchoring ring

This is used to adjust the front-back position of the viewfinder.

<Note>

For details, refer to "5-2 Attaching the viewfinder and adjusting its position."

Chapter 3 Recording and playback

3-1 Cassette tapes

Loading a cassette tape

1 Set the POWER switch to ON.

<Note>

When condensation has formed inside the unit, the HUMID display lights. Wait until this display is cleared before proceeding with the intended operation.

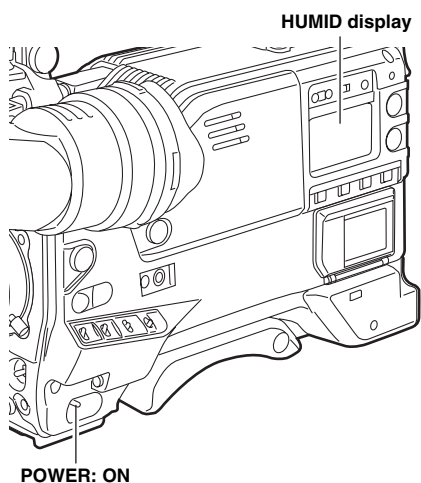

2 Press the EJECT button.
The cassette holder opens.

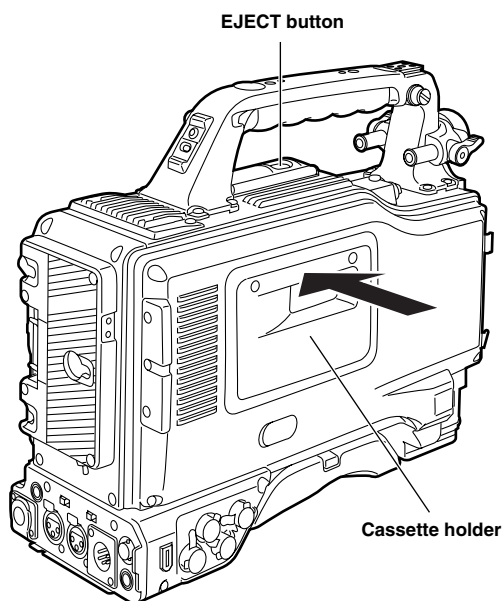

3 Insert the cassette tape and press the part marked with the arrow to close the cassette holder securely.

<Note>

Check that there is no slack in the tape of the cassette.

Checking for tape slack

Gently push in the reel using your finger and turn the reel in the direction of the arrow. If the reel fails to turn, it means there is no tape slack.

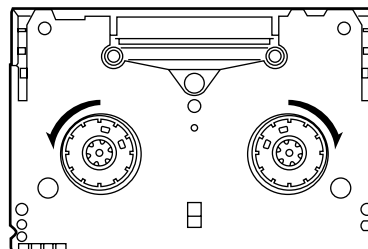

Ejecting the cassette tape

While the power is still on, press the EJECT button to open the cassette holder, and take out the cassette tape. If another cassette is not going to be loaded immediately after this tape is ejected, close the cassette holder.

Ejecting the cassette when the battery has no charge

First, set the POWER switch to OFF to turn off the unit's power.

Then turn the power back on, and immediately hold down the EJECT button.

The cassette can be removed when there is still some power left in the battery. However, do not repeat this operation.

To prevent accidental erasure

Set the cassette's tab to SAVE to prevent the recordings on the tape from being erased accidentally.

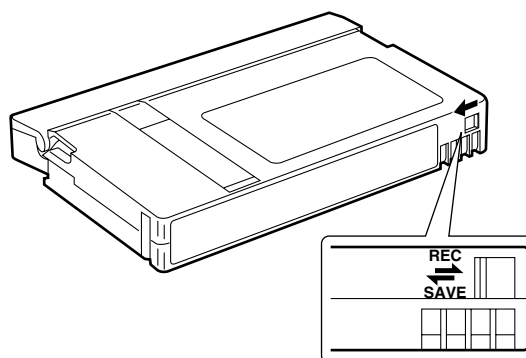

Chapter 3 Recording and playback

3-2 Basic procedures

This section describes the basic steps for shooting and recording.

Before actually departing to shoot scenes, carry out inspections to ensure that the system is functioning properly.

* For details on how to perform these inspections, refer to “6-1 Inspections prior to shooting.”

From providing the power supply to loading the cassette

- 1 Attach a fully charged battery pack.
- 2 Set the POWER switch to ON. Now check that the HUMID display is not showing and that at least 5 segments of the remaining battery charge display are lighted.
 - If the HUMID display is showing, wait until it goes off.
 - When five or more segments of the remaining battery charge display have not lighted, first check the battery setting. If there is nothing wrong with the battery setting, replace the existing battery pack with a fully charged battery pack.
- 3 Check that there are no cables around the cassette holder or top panel, and then press the EJECT button to open the cassette holder.
- 4 After checking the following points, insert the cassette tape and close the cassette holder.
 - Position of the accidental erasure prevent tab
 - Tape slack

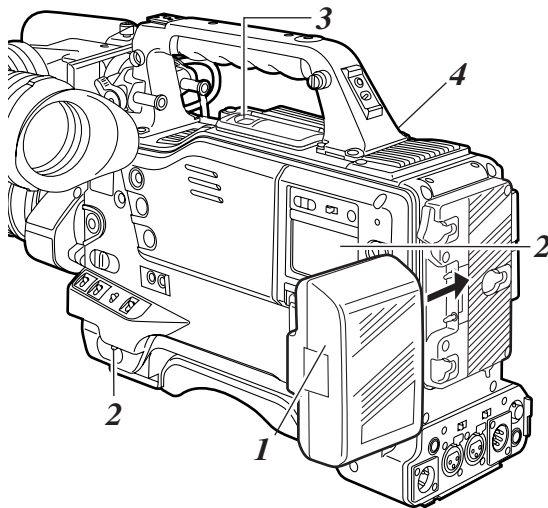

Up to performing the switch settings

Provide the power supply, and load the cassette. Next, set each switch as shown in the figure below, and then proceed to operate.

Switch settings for shooting and recording

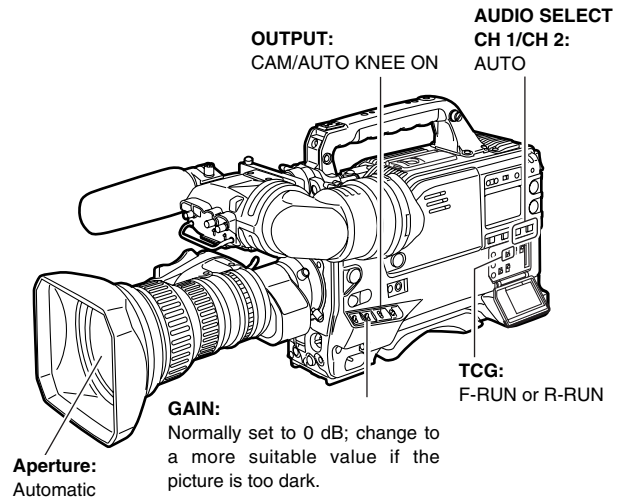

Chapter 3 Recording and playback

Procedure for shooting

From adjusting the white balance and black balance to stopping the recording

From adjusting the white balance and black balance to stopping the recording

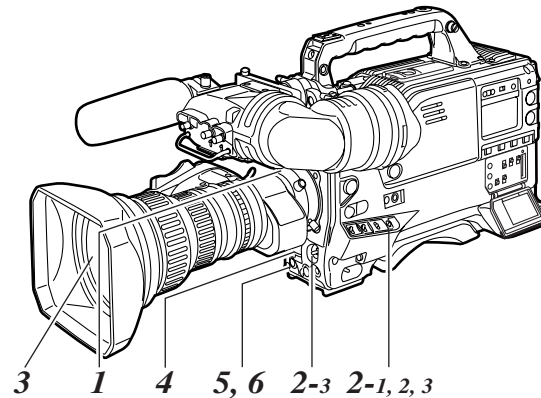

1 Select the filter to match the lighting conditions.

2-1 If the white balance has been stored in the memory ahead of time:

Set the WHITE BAL switch to “A” or “B.”

2-2 If the white balance and/or black balance have not been stored in the memory and there is no time to adjust the white balance:

Set the WHITE BAL switch to PRST.

The white balance for the filter is achieved in accordance with the setting position of the FILTER control (outer).

2-3 When adjusting the white balance on the spot:

Select the filter to match the lighting conditions, set the WHITE BAL switch to “A” or “B” and adjust the white balance as follows:

- ① Press the AUTO W/B BAL switch to the AWB position and adjust the white balance.
- ② Press the AUTO W/B BAL switch to the ABB position and adjust the black balance.
- ③ Press the AUTO W/B BAL switch to the AWB position and adjust the white balance again.

* For details on how to perform the adjustments, refer to “4-1-1 Adjusting the white balance” and “4-1-2 Adjusting the black balance.”

3 Point the camera at the subject, and adjust the focus and zoom.

4 When the electronic shutter is to be used, set the shutter speed and operating mode.

* For further details, refer to “4-2 Setting the electronic shutter.”

5 Press the VTR START button or lens VTR button to start recording.
During recording, the REC lamp inside the viewfinder lights.

6 To stop the recording, press the VTR START button again.
The REC lamp inside the viewfinder goes off.

Tape function buttons

During recording, the tape function buttons (EJECT, REW, FF, PLAY/PAUSE and STOP) will not work.

Chapter 3 Recording and playback

3-3 Scene-to-scene continuity

Maintaining continuity from one scene to the next at an accuracy of +1 frame or less can be assured simply by pressing the VTR START button or VTR button on the lens while the unit is in the rec-pause mode.

If the unit is in a mode other than rec-pause, the point at which the scene-to-scene continuity is to be maintained must be located before recording is started.

Scene-to-scene continuity during rec-pause

The scene-to-scene continuity timing is located automatically. However, the time taken until the start of recording differs depending on the setting of the VTR SAVE/STBY switch.

- When the VTR SAVE/STBY switch is set to SAVE, recording commences about two seconds after the VTR START button is pressed.
- When the VTR SAVE/STBY switch is set to STBY, recording commences as soon as the VTR START button is pressed.

Ensuring scene-to-scene continuity after the power was turned off while the unit was in the rec-pause mode

- 1 Switch the power back on.
- 2 Press the VTR START button or lens VTR button to start the recording.

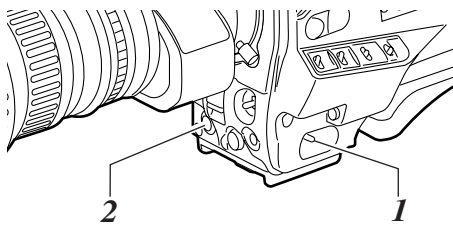

Ensuring scene-to-scene continuity at other times

Proceed as follows either after the tape has been allowed to run or after the cassette has been ejected or when ensuring continuity on a tape which has been recorded only in part.

- 1 While monitoring the viewfinder screen, press the PLAY/PAUSE button to play back the tape.
- 2 At the place on the tape where continuity is to be maintained, press the PLAY/PAUSE (or STOP) button again to stop the tape.

- 3 Press the lens RET button. It takes about two seconds to complete the preparations for the scene-to-scene continuity.
- 4 Press the VTR START button or lens VTR button to start the recording.

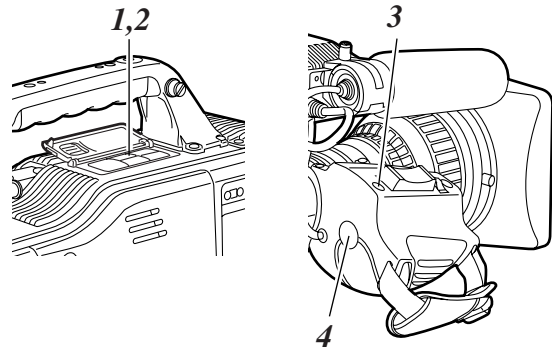

It is also possible for the function of the VTR START button or VTR button on the lens to be allocated to the USER MAIN, USER1 or USER2 button. For details, refer to "4-8-4 Allocating functions to the USER MAIN, USER1 and USER2 buttons."

3-4 NEWS REC function SDC615

The NEWS REC function is set using the NEWS REC MODE item after opening the <REC FUNCTION> screen from the SYSTEM SETTING page by performing menu operations. By controlling the VTR START button acknowledgment time during recording (by up to 2 seconds), the time taken for the unit to transfer from the recording mode to the rec-pause mode can be delayed.

In other words, by controlling the VTR START button operation acknowledgment time, the unit can continuously record without the user having to interrupt the recording: this safeguards against the failure to record those precious moments—a failure that occurs when recording is resumed immediately after it was shut down temporarily.

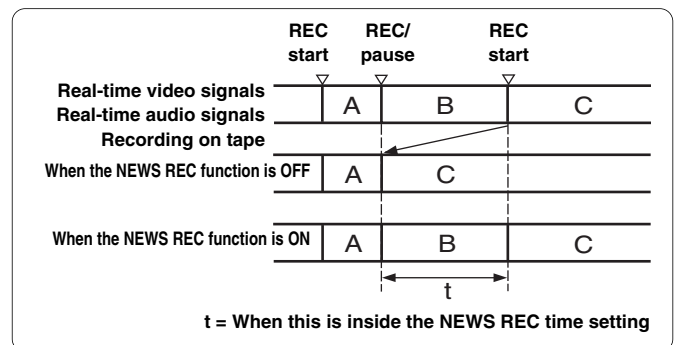

Chapter 3 Recording and playback

3-5 PRE-RECORDING function **SDC905**

By always storing a few seconds' worth (maximum of 6 seconds) of audio and video data shot by the camera, it is possible to record video and audio signals a number of seconds before recording is actually started by pressing the VTR START button or the VTR button on the lens.

In order for this function to be used, it is necessary to open the <REC FUNCTION> screen from the SYSTEM SETTING page and set the data storage time in the memory using the PRE REC MODE item by performing menu operations.

The PRE REC MODE item settings are described below.

OFF: The PRE-RECORDING function is not activated.

0-6SEC: A value from 1 to 6 seconds is set as the length of time for which the video and audio signals can be recorded before the VTR START button or VTR button on the lens is pressed.

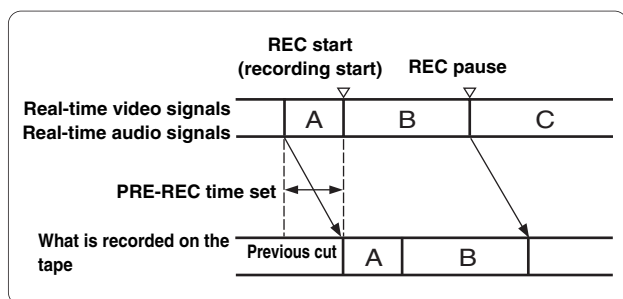

<Notes>

- The data contained in the storage memory becomes unstable immediately after the power is turned on, immediately after the PRE REC MODE item setting is selected or its set time has been changed, and immediately after playback or rec-review has been performed. Immediately after any of these operations, therefore, the video and audio signals will not be pre-recorded for the duration set when recording is started by pressing the VTR START button or VTR button on the lens.
- The video data and audio data are not stored in the storage memory while playback or rec-review is being performed. This means that the pre-recording will not include the video and audio signals supplied during a playback or rec-review operation.
- Since it will take a few moments for recording to commence when the unit is in the tape protection mode, the pictures and sound will not be recorded at the time which has been set.
- The pre-recording function will not work when the <SYSTEM MODE> screen is opened from the SYSTEM SETTING page by performing menu operations and 1394 is selected as the REC SIGNAL menu item setting.
- When recording has been started, the time code (TCG) display may remain in the hold status until it is possible for the time code (TCR) on the tape to be read.

3-6 INTERVAL REC function

The AJ-SDC905 **SDC905** enables recording in intervals with a minimum recording time in increments of one frame to be conducted.

The AJ-SDC615 **SDC615** enables recording in intervals with a recording time of 2 seconds or more to be conducted.

In order for this function to be used, it is necessary by performing menu operations to open the <REC FUNCTION> screen from the SYSTEM SETTING page, select the interval recording mode using the INTERVAL REC MODE item, and set the recording time (REC TIME), interval pause time (PAUSE TIME) and time required for shooting (TOTAL TAKE TIME). Upon completion of the settings, the total shooting time (TOTAL REC TIME) is automatically calculated and displayed.

The INTERVAL REC MODE item settings are described below.

OFF: Interval recording is not performed.

ON: Interval recording is performed.

ONE SHOT:

One-shot interval recording is performed for the time which was selected by the REC TIME setting.

Procedure for shooting in the ON modes of INTERVAL REC

- 1 After performing the basic operations for shooting and recording as set forth in "3-2 Basic procedures," secure the unit in such a way that it will not move.
- 2 Press the unit's VTR START button or the VTR button on the lens. Interval recording now starts. When the set TOTAL TAKE TIME has elapsed, recording is ended automatically. As mentioned in "2-7 Display window and its displays," "i" flashes when the INTERVAL REC mode is selected. As soon as recording starts, "iREC" lights. During rec-pause, "iREC" flashes. Exactly what mode is established in the unit can be ascertained by observing these displays. The same displays as the ones in the display window also appear inside the viewfinder, and the TALLY lamp lights while recording is underway. Further, when the pause time has been set to 2 minutes or more, the tally lamp blinks at 5 second intervals to inform the operator. Further, when pause time has been set to 2 minutes or more, the tally lamp blinks at 5 second intervals to indicate when recording is paused. Under these conditions, the tally lamp will also flash 3 seconds before recording starts.

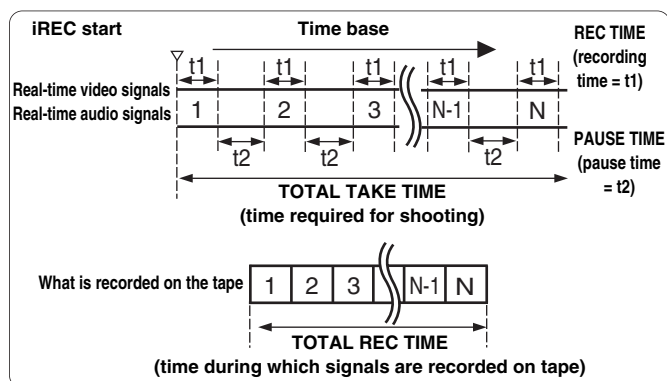

Chapter 3 Recording and playback

When recording is to be suspended at any time

Press the STOP button. Recording is now suspended.

- With the AJ-SDC905 **SDC905**, the tape may continue to run since the unit will record the images stored in the memory until the moment when the button is pressed.

When the recording is to be continued

Press the unit's VTR START button or VTR button on the lens once more. Interval recording is now started again.

When the INTERVAL REC mode is to be exited

There are two ways to do this.

- 1) Set the unit's POWER switch to OFF.
- 2) Perform a menu operation and select OFF as the INTERVAL REC MODE item setting.

Procedure for shooting in the ONE SHOT mode

Follow the procedure below for shooting after the settings for the interval recording mode have been completed.

- 1 After performing the basic operations for shooting and recording as set forth in "3-2 Basic procedures," secure the unit in such a way that it will not move.
- 2 Press the unit's VTR START button or the VTR button on the lens. When the set REC TIME has elapsed, the recording is ended automatically. As mentioned in "2-7 Display window and its displays," "i" flashes when the INTERVAL REC mode is selected. As soon as recording starts, "iREC" lights. When the recording ends, "iREC" flashes. The same displays as the ones in the display window also appear inside the viewfinder, and the TALLY lamp lights while recording is underway.

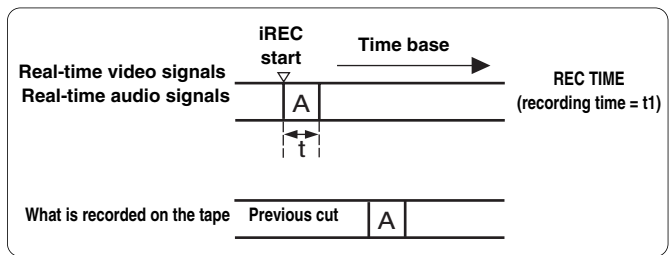

When the recording is to be continued

Press the unit's VTR START button or VTR button on the lens once more. One-shot recording is now started again.

When the ONE SHOT mode of INTERVAL REC is to be exited

There are two ways to do this.

- 1) Set the unit's POWER switch to OFF.
- 2) Perform a menu operation and select OFF as the INTERVAL REC MODE item setting.

Checkpoints common to all INTERVAL REC modes

- The interval recording function will not work when the <SYSTEM MODE> screen is opened from the SYSTEM SETTING page by performing menu operations and 1394 is selected as the REC SIGNAL menu item setting.
- **Sound-related**
Whether the sound is to be recorded or not during interval recording is set by setting ON or OFF for the AUDIO REC item on the <REC FUNCTION> screen.
- **Tape function button-related**
During interval recording, all the tape function buttons (EJECT, REW, FF and PLAY/STILL) except STOP do not work.
- **Starting recording quickly when unit is in pause mode**
Selecting REC as the setting for one of either USER MAIN or USER1/USER2 buttons in advance enables quick start recording during pause mode when the set button is pressed. Measurement of pause mode time is continued even after quick start recording.
- **When the unit's power was turned off during recording**
SDC905
If the unit's POWER switch was set to the OFF position during interval recording with the use of the memory, the tape will continue to run in order to record the video signals which were stored in the memory until the moment when the POWER switch was set to OFF, and then the power will automatically go off.
If the battery was removed, the DC cable was disconnected or the power supplied through the AC adapter was cut off during recording, those shots (up to 6 seconds) taken prior to the moment concerned may not be recorded. Bear this in mind when the battery is to be replaced.
- **When the tape has run out during recording** **SDC905**
Bear in mind that if the tape has run out and stops during interval recording with the use of the memory, those shots (up to 6 seconds) taken prior to the moment when the tape stopped may not be recorded.
- With the AJ-SDC905 **SDC905**, if a PLAY, FF or REW operation is performed after one-shot recording, the operation will be performed after the images remaining in the memory are written on the tape.
While the images are being recorded, the LED of the button pressed (for play, FF or REW operation) will flash.
- **Concerning the time code display** **SDC905**
When recording has been started, the time code (TCG) display may remain in the hold status until it is possible for the time code (TCR) on the tape to be read.

Chapter 3 Recording and playback

3-7 RETAKE function

The RETAKE function ensures continuity with the previous cut on the tape when shooting is resumed.

It is set by opening the <REC FUNCTION> screen from the SYSTEM SETTING page and selecting ON as the setting for the RETAKE MODE item by performing menu operations.

The RETAKE MODE item settings are described below.

ON: The retake operation is performed when the RET button on the lens is pressed while the MODE CHECK button is held down.

OFF: The RETAKE function does not operate.

If, when the rec-pause mode is established upon completion of the recording or the stop mode is established afterwards, the RET button on the lens is pressed while the MODE CHECK button is held down, the tape will be rewound to the approximate start point (a position advanced by 10 or so frames from the recording start) of the final image that was last recorded, and the rec-pause mode will be established.

If there is some leeway in the shooting time and a "NG" condition has been clearly identified, recording can be started from this point, and the cut in the NG area will be deleted.

This function is particularly useful for cutting the amount of time taken for copying onto work tapes and other such economical operations.

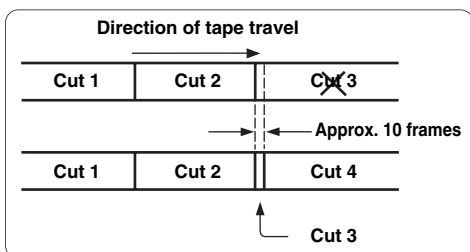

When the RETAKE function is to be exited

There are two ways to do this.

- 1) Set the unit's POWER switch to OFF.
- 2) Perform a menu operation and select OFF as the RETAKE MODE item setting.

3-8 Rec-review function

When recording is temporarily stopped and the lens RET button is pressed, the last two seconds of the tape are automatically rewound, and the playback pictures on this part of the tape appear on the viewfinder screen. This makes it possible to check whether recording was performed properly.

After the two seconds of the tape have been played back, the unit is again set to the recording start standby mode.

If the RET button is held down, a maximum of 10 seconds of the tape is rewound and played back.

The RET button function can be allocated by opening the <USER SW> screen from the OPERATION page and selecting settings for the USER MAIN SW, USER1 SW and USER2 SW items by performing menu operations.

<Note>

- The rec-review function cannot be used unless recording lasts for one or more seconds.
- If the OUTPUT SEL switch on the side panel is at the VTR position during the rec-review operation, the rec-review images are output not only to the viewfinder but to the video output connectors (VIDEO OUT connector and MON OUT connector) as well. Bear in mind that if back-up images are being recorded by a backup VTR that has been connected, these rec-review images will end up being recorded.

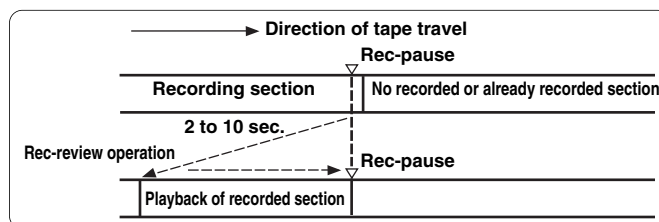

3-9 Normal playback and playback at different speeds

Black-and-white playback images can be viewed in the viewfinder by pressing the PLAY button. At the same time, color playback images can be viewed if a color video monitor is connected to the unit's VIDEO OUT connector and MON OUT connector.

- In order to view these images, the OUTPUT SEL switch on the side panel must be set to the VTR position.

In addition, when the FF and REW buttons are used, the images can be played back at different speeds by establishing the cue mode (PLAY + FF), review mode (PLAY + REW), high-speed fast forward playback mode (FF) or high-speed rewind playback mode (REW).

Chapter 4 Adjustments and settings for recording

In order to achieve images with a consistently high picture quality with this unit, it is necessary to adjust the black balance and white balance as the individual conditions demand. To achieve a higher picture quality, it is recommended that the adjustments be performed in the following sequence: AWB (white balance adjustment) → ABB (black balance adjustment) → AWB (white balance adjustment).

4-1 Adjusting the white balance and black balance

4-1-1 Adjusting the white balance

The white balance must always be re-adjusted when the lighting conditions have changed. The white balance is adjusted automatically by following the steps below.

1 Set the switches as shown in the figure.

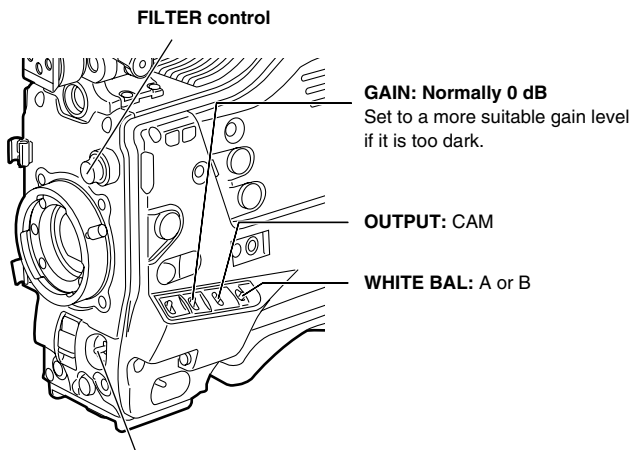

AUTO W/B BAL switch:
Use this to execute AWB.

2 Select the FILTER control setting in accordance with the lighting conditions.

<Note>

For examples of the FILTER control settings, refer to “2-3 Shooting and recording/playback function section.”

3 Erect a white pattern at a place with the same conditions as the source of light illuminating the subject, zoom in, and shoot the white of the pattern on the screen. A white object (such as a white cloth or white wall) near the subject may be used as a substitute for the white pattern. The size of the white object required is shown in the figure below.

<Notes>

- Take care to keep high-brightness spots off the screen.
- Shoot white objects in the center of the screen.

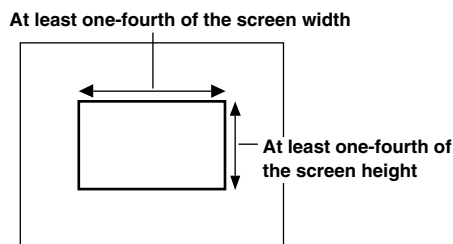

4 Adjust the lens aperture.

5 Set the AUTO W/B BAL switch to AWB, and then release it.

The switch returns to the center, and the white balance is automatically adjusted.

<Note>

When the AUTO W/B BAL switch is pressed again to the AWB side when the white balance is being adjusted automatically (AWB ACTIVE), the adjustment operation will stop.

The adjusted value in this case is the value before automatic adjustment was performed.

6 While the adjustment is in progress, the following message appears on the viewfinder screen.

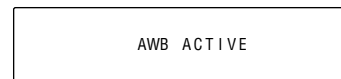

7 Adjustment is completed in several seconds. (A message similar to the one shown in the figure below now appears.)

The adjustment value is automatically saved in the memory (A or B) which was set in step 1.

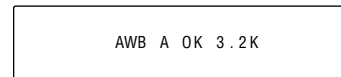

8 The message shown in the figure below appears when the color temperature of the subject falls below 2300 K or rises above 9900 K.

The downward pointing arrow indicates that the color temperature is lower than the display temperature; conversely, an upward pointing arrow indicates that it is higher than the display temperature.

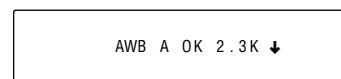

White balance detection area

The white balance detection area setting can be changed to 90%, 50% or 25% by opening the <WHITE BALANCE MODE> screen from the OPERATION page and selecting the desired setting for the AWB AREA item by performing menu operations.

The factory setting is 25%.

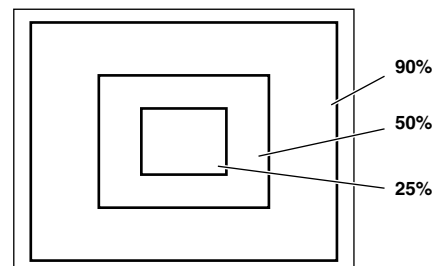

Chapter 4 Adjustments and settings for recording

When there is no time to adjust the white balance

Set the WHITE BAL switch to PRST. The white balance for the filter is achieved in accordance with the setting position of the FILTER control (outer).

When the white balance cannot be adjusted automatically

When the white balance adjustment was not completed correctly, one of the following error messages will appear on the viewfinder screen. When an error message is displayed, take the recommended action, and try adjusting the white balance again. If the error message persists even after repeated attempts, the inside of the unit must be inspected. For details, contact your nearest service center or your dealer.

Messages relating to white balance adjustment

Error message	Meaning	Recommended action
COLOR TEMP. HIGH	Color temperature is too high.	Select a suitable filter.
COLOR TEMP. LOW	Color temperature is too low.	Select a suitable filter.
LOW LIGHT	There is not enough light.	Increase the amount of light or increase the gain.
LEVEL OVER	There is too much light.	Reduce the amount of light or reduce the gain.
CHECK FILTER	The setting position of the filter selector control is not correct.	Check the filter selector control.
TIME OVER	AWB was not completed within the allotted time.	The shooting conditions may be unstable. If flicker occurs, engage the shutter and shoot again under stable conditions.

White balance memories

The values stored in the memories are retained even after the unit's power has been turned off until the white balance is next adjusted. There are two sets of white balance memories, A and B.

When ON has been selected (initial setting) as the setting for the FILTER INH item on the <WHITE BALANCE MODE> screen opened from the OPERATION page by performing menu operations, the number of memories is limited to one in A and one in B. In this case, the memory contents are not coupled with the CC filter.

When FILTER INH is set to OFF, the adjustment values for each CC filter can be automatically saved in the memories corresponding to the WHITE BAL switch settings (A or B). This unit contains four filters so that a total of 8 (4×2) adjustment values are saved.

Note that when VAR has been selected for AWB A and AWB B items of the <WHITE BALANCE MODE> screen, the values will be the fixed color temperature settings established with the COLOR TEMP A and COLOR TEMP B settings and they cannot be adjusted using the AWB switch.

Auto tracking white balance setting

This unit comes with an auto tracking white balance (ATW) function for automatically tracking the white balance of the images in accordance with the lighting conditions. This function can be set in WHITE BAL switch B.

Open the <WHITE BALANCE MODE> screen from the OPERATION page and select ATW for the <AWB B> item by performing menu operations.

The ATW function can also be allocated to the USER MAIN, USER1 or USER2 button. For details, refer to "4-8-4 Allocating functions to the USER MAIN, USER1 and USER2 buttons."

To release the auto tracking white balance

Either press again the USER button to which ATW has been allocated or select a different position for the WHITE BAL switch.

```
→ < WHITE BALANCE MODE >
  FILTER INH       : ON
  SHOCKLESS AWB   : NORMAL
  AWB AREA        : 2.5%

  AWB&ABB OFFSET  : OFF
  AWB A           : MEM
  COLOR TEMP A    : 3200K
  AWB B           : MEM
  COLOR TEMP B    : 3200K
  ATW SPEED       : NORMAL
```

<Note>

This function is not meant to give a 100% guarantee for the accuracy of the white balance.

Some leeway has been given to both the function's ability to track changes in the lighting conditions and the accuracy with which the white balance is tracked. For this reason, handle the function carefully.

Viewfinder screen displays relating to the white balance

For details, refer to "4-7 Viewfinder screen status displays."

Chapter 4 Adjustments and settings for recording

4-1-2 Adjusting the black balance

The black balance needs to be adjusted in the following cases:

- When the unit is used for the first time
- When the unit is used after it has not been used for a prolonged period of time
- When the unit is used in an ambient temperature which has fluctuated significantly
- When the value selected for the gain switch has been changed
- When the super gain setting has been performed using the USER MAIN, USER1 or USER2 button
- When the gamma ON/OFF setting has been changed

1 Set the switches as shown in the figure.

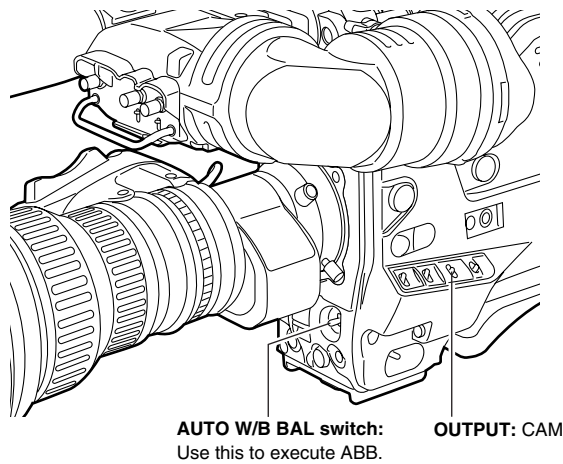

2 Set the AUTO W/B BAL switch to the ABB position, and then release it. The switch returns to the center, and the adjustment is performed.

3 While the adjustment is in progress, the following message appears on the viewfinder screen.

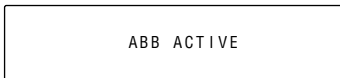

<Note>

While the adjustment is in progress, the lens aperture is automatically set to CLOSE.

4 Adjustment is completed in several seconds. (A message similar to the one shown in the figure below now appears.) The adjustment value is automatically saved in the memory.

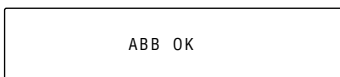

<Notes>

- Check that the lens connector has been connected and that the lens aperture is set to CLOSE.
- While the black balance is being adjusted, the aperture is automatically set to the light-shielding status.
- While the black balance is being adjusted, the gain selector circuit is switched automatically. Flicker or noise may appear on the viewfinder screen, but this is not indicative of malfunctioning.
- If the black shading is still unsatisfactory although the "ABB OK" message is displayed, perform menu operations to open the <BLACK SHADING> screen from the MAINTENANCE page, move the arrow mark (→) to the DETECTION item, press the JOG dial button, and proceed with the black shading adjustment. If the ABB switch is held down for 5 or more seconds, the black shading can be automatically adjusted after the ABB operation. (See the SHD.ABB SW CTL item under "7-5-5 SW MODE.")
- If the AUTO W/B BAL switch is pushed down to the ABB position again while the black balance is being automatically adjusted (ABB ACTIVE), the adjustment will be aborted. The adjusted value in this case is the value before automatic adjustment was performed.

Black balance memory

The values stored in the memory are retained even after the unit's power has been turned off.

Chapter 4 Adjustments and settings for recording

4-2 Setting the electronic shutter

This section describes the unit's electronic shutter, its settings and operations.

4-2-1 Shutter modes

The table below lists the shutter modes in which the unit's electronic shutter can be used as well as the shutter speeds which can be selected.

Mode	Shutter speed	Applications
Standard	POSITION1 - 6	For shooting fast-moving subjects clearly.
SYNCHRO SCAN	Within the 50.4 Hz to 248.0 Hz range	For shooting monitor screens with a vertical scanning frequency exceeding 50 Hz in a way that minimizes the pattern of horizontal lines.
SUPER V		For improving the vertical resolution.

<Notes>

- No matter in which mode the electronic shutter is used, the higher the shutter speed, the lower the camera's sensitivity.
- When the aperture is in the automatic mode, it will increasingly open and the depth of focus will become shallower as the shutter speed is increased.
- The electronic shutter will not function when the cumulative gain-boosting DS. GAIN (digital super gain) mode is in use.

4-2-2 Setting the shutter mode and speed

The shutter speeds used in the shutter mode are set by switching the SHUTTER switch.

The shutter speeds in the SYNCHRO SCAN mode can easily be changed using the SYNCHRO SCAN (+ and -) buttons on the side panel.

Open the <SHUTTER SPEED> screen and <SHUTTER SELECT> screen from the OPERATION page by performing menu operations. It is now possible to restrict the shutter speed selection range to the required range beforehand and/or select whether to use the SYNCHRO SCAN mode and SUPER V mode beforehand.

Once selected, the shutter speed is retained even after the unit's power has been turned off.

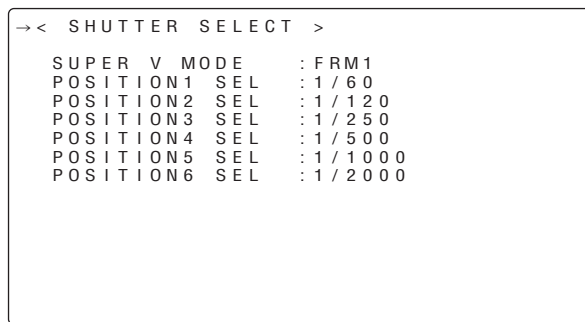
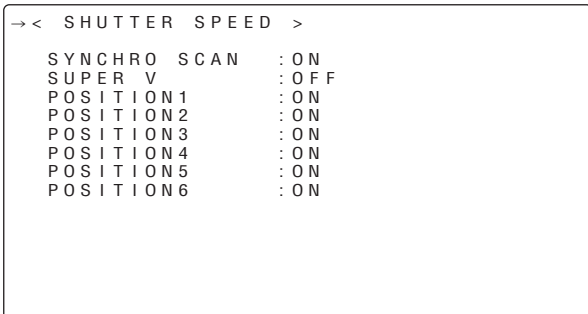

1 Press the SHUTTER switch from ON to SEL.

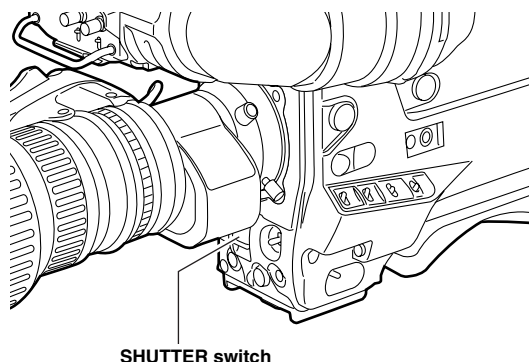

2 Press the SHUTTER switch to the SEL position again, and repeat this until the desired mode or speed is displayed.

When all the modes and speeds are displayed, the display will change in the sequence shown below.

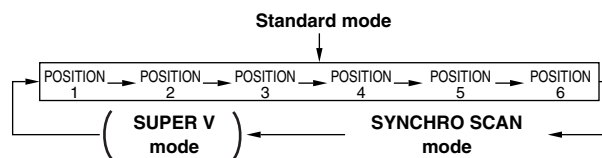

<Note>

Since the factory setting for the SUPER V mode is OFF, there is no display at this setting. To designate the mode, open the <SHUTTER SPEED> screen from the OPERATION page and select ON for the SUPER V item setting by performing menu operations.

Viewfinder screen displays relating to the shutter

For details, refer to "4-7 Viewfinder screen status displays."

Chapter 4 Adjustments and settings for recording

4-2-3 Setting the synchro scan mode

Proceed with operation by following the steps below.

- 1 Press the SHUTTER switch from ON to SEL to establish the SYNCHRO SCAN mode.

SYNCHRO SCAN (+ and -) buttons

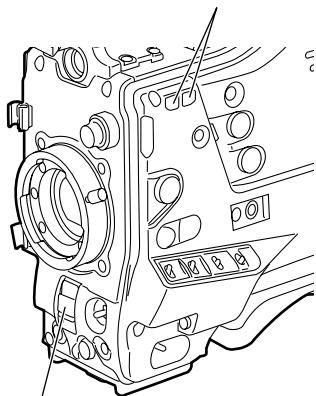

SHUTTER switch

- 2 In the SYNCHRO SCAN mode, it is possible to change the shutter speed continuously within a range from 1/50.4 sec. to 1/248.0 sec. by operating the SYNCHRO SCAN (+ and -) buttons.

4-3 Selecting the recording signals and recording system

With this unit, both the signals to be recorded and the recording format can be selected.

4-3-1 Selecting the recording signals

Open the <SYSTEM MODE> screen from the SYSTEM SETTING page and select the signals to be recorded using the CAMERA MODE item by performing menu operations.

SDC905

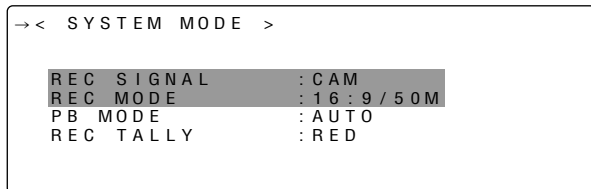

SDC615

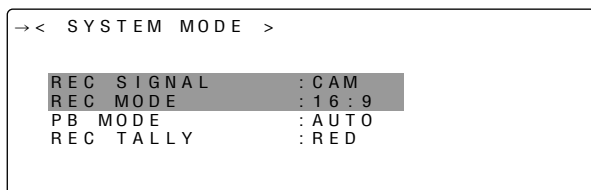

Items to be set and what is set

The signals to be recorded are selected using REC SIGNAL.

- CAM:** The signals from the camera are recorded.
- VIDEO:** The signals from the GENLOCK IN connector are recorded.
The images may be disrupted when the signals from the GENLOCK IN connector are non-standard signals.
- 1394:** The signals from the DVCPRO connector are recorded.

Bear the following points in mind when 1394 is selected as the setting.

- Connect the unit to external units on a 1-on-1 basis.
- The sound is recorded using the audio signals supplied to the DVCPRO connector but its input level cannot be adjusted.
At a time like this, nothing is recorded on the cue track.
- The cue signals cannot be input or output.
- When the TCG switch is at the F-RUN position, the time code supplied to the DVCPRO connector is recorded.
- When the TCG switch is at the R-RUN position, the recording is performed using the time code which has been recorded on the tape.
- When EXT is selected as the UB MODE item setting on the <TC/UB> screen by performing menu operations, the user bits which are supplied to the DVCPRO connector are recorded.
- The user bits which are supplied to the DVCPRO connector are recorded in the vertical blanking period regardless of the VITC UB MODE item setting.
- It is not possible to record the time code which is supplied to the TC IN connector.
- The time code which is output from the TC OUT connector is not synchronized with the video output signals or the output signals from the DVCPRO connector.
- The signals which are output from the VIDEO OUT connector, MON OUT connector or AUDIO OUT connector differ from the actual signals. Use them for monitoring purposes.
- It is not possible to use the GENLOCK IN connector to achieve synchronization with the external reference signal.
- The signals may be disrupted when the power of the connected units is switched from ON to OFF or vice versa or when the interface cable is connected or disconnected.
- It may take several seconds for the system to stabilize immediately after the input signals are switched or immediately after the operation mode is changed, for instance.
Wait until the system has stabilized before proceeding with recording.
- Supply normal playback speed (1× speed) signals. When playback signals of any other speed are supplied, the images and sound may not be recorded properly.
- The pre-recording function **SDC905** and Interval REC function do not work.
- Characters other than the ones that are used in the menus are not displayed on the viewfinder screen and output images.
Similarly, the same are not displayed when VIDEO is selected.

Chapter 4 Adjustments and settings for recording

4-3-2 Selecting the recording system

Open the <SYSTEM MODE> screen from the SYSTEM SETTING page and select the format of the VTR to be used for recording using the REC MODE item by performing menu operations.

Concerning what is set

16:9/50M **SDC905**:

Signals are recorded in the DVCPRO50 format (50 Mbps) with an aspect ratio of 16:9.

4:3/50M **SDC905**:

Signals are recorded in the DVCPRO50 format (50 Mbps) with an aspect ratio of 4:3.

16:9/25M **SDC905**, 16:9 **SDC615**:

Signals are recorded in the DVCPRO format (25 Mbps) with an aspect ratio of 16:9.

4:3/25M **SDC905**, 4:3 **SDC615**:

Signals are recorded in the DVCPRO format (25 Mbps) with an aspect ratio of 4:3.

4-4 Selecting the audio input signals and adjusting their recording levels

When the AUDIO SELECT CH1/CH2 switch is set to AUTO, the recording levels on audio tracks CH1 and CH2 are adjusted automatically. On the other hand, when it is set to MAN, the levels can be adjusted manually.

SDC905

- The same signals as for CH1 are recorded on audio track CH3. Similarly, the same signals as for CH2 are recorded on audio track CH4.
- The signals are recorded on two channels (CH1 and CH2) when the DVCPRO format (25 Mbps) is set.
- The test tone is output in accordance with what is selected as the TEST TONE menu item setting on the <MIC/AUDIO> screen from the VTR MENU page.

4-4-1 Selecting the audio input signals

Use the AUDIO IN switch to select the input signals to be recorded on audio tracks CH1 and CH2.

For details, refer to “2-2 Audio function section.”

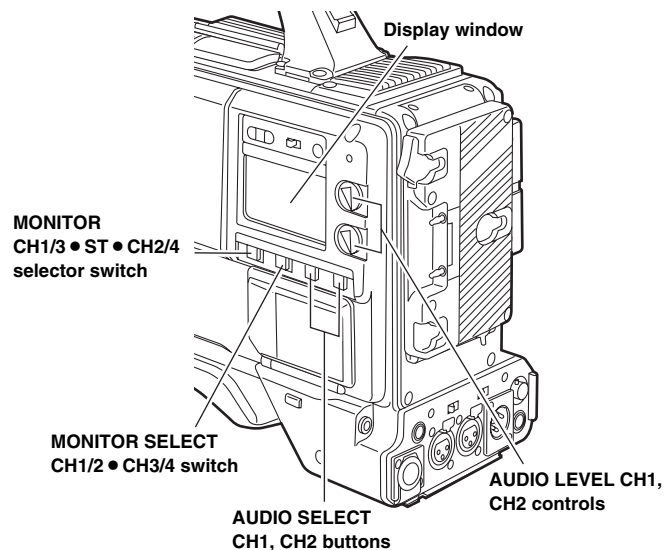

For the detailed audio-related settings, open the <MIC/AUDIO1> and <MIC/AUDIO2> screens from the VTR MENU page and select the settings for the items by performing menu operations.

For details, refer to “Chapter 7 Menu description tables.”

-> < MIC / AUDIO 1 >	
FRONT VR CH1	: OFF
FRONT VR CH2	: OFF
MIC LOWCUT CH1	: OFF
MIC LOWCUT CH2	: OFF
LIMITER CH1	: OFF
LIMITER CH2	: OFF
CUE REC SELECT	: CH1
TEST TONE	: NORMAL

-> < MIC / AUDIO 2 >	
FRONT MIC POWER	: ON
REAR MIC POWER	: ON
AUDIO OUT	: ON
MONITOR SELECT	: STEREO
FRONT MIC LEVEL	: -40dB
REAR MIC CH1 LVL	: -60dB
REAR MIC CH2 LVL	: -60dB
REAR LINE IN LVL	: +0dB
AUDIO OUT LVL	: +0dB
HEADROOM	: 18dB
WIRELESS WARN	: OFF

4-4-2 Adjusting the audio signal recording levels

The procedure for manually adjusting the levels at which the signals are to be recorded on audio tracks CH1 and CH2 is set forth below.

- 1 Set the MONITOR SELECT switch to the CH1/2 position so that the audio level meter display in the display window indicates CH1 and CH2, and check that 1 and 2 are actually indicated as the display in the display window. Before proceeding any further, on the menu, set whether to activate the F.AUDIO LEVEL controls which are used for attenuation. (At the factory, the mode in which these controls are inactive is established.)
- 2 Set the AUDIO SELECT CH1 and CH2 buttons to MAN (manual).
- 3 While monitoring the audio level meter in the display window or the audio level meter display inside the viewfinder, adjust the AUDIO LEVEL CH1 and CH2 controls. If the uppermost bar (0 dB) is exceeded, the “OVER” display lights up to indicate that the input volume is too high. The level must be adjusted so that 0 dB will not be indicated even under maximum volume conditions.

Chapter 4 Adjustments and settings for recording

Audio level meter in display window

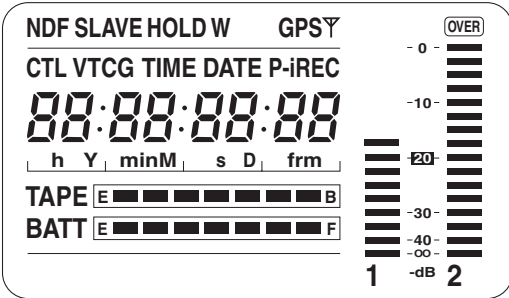

Audio level meter display inside viewfinder



For the audio levels to be adjusted by one person only, it is recommended that the F.AUDIO LEVEL controls be used. Select in advance the audio channels whose levels are to be adjusted, and while monitoring the level meter on the viewfinder screen, adjust the F.AUDIO LEVEL controls in such a way that the input will not be too high.

4-5 Setting the time data

The time code setting range extends from 00:00:00:00 to 23:59:59:24.

4-5-1 Setting the user bits

Memos and other information with up to 8 digits (dates, times) in hexadecimal notation can be recorded on the sub code track by setting the user bits.

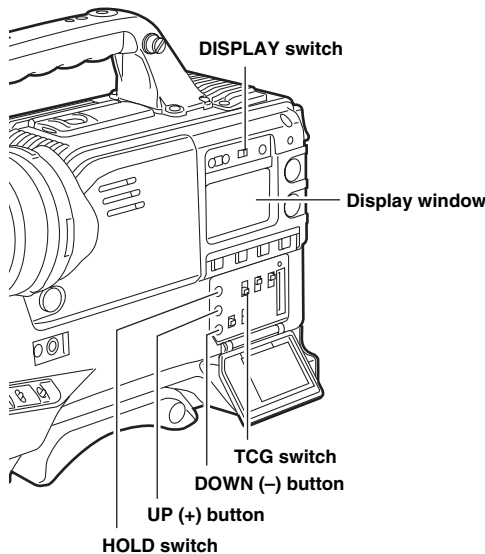

- 1 Set the DISPLAY switch to UB.
- 2 Set the TCG switch to SET.
- 3 Set the user bits using the SHIFT button, UP (+) button and DOWN (-) button.
 - SHIFT button:** This is used to cause the digit that is to be set to flash. Each time it is pressed, the flashing digit moves to the right.
 - UP (+) button:** This increments the numerical value of the flashing digit by 1.
 - DOWN (-) button:** This decrements the numerical value of the flashing digit by 1.
- 4 Set the TCG switch to F-RUN or R-RUN.
- 5 Open the <TC/UB> screen from the VTR MENU page and select USER as the UB MODE item setting by performing menu operations.

User bit memory function

The user bit settings (except for the actual time) are automatically saved in the memory and retained even after the power is turned off.

Tape continuity with the user bits

Selecting REGEN for the UB MODE item on the <TC/UB> screen by performing menu operations will call up the user bits recorded on the tape, making it possible to continue recording from that value. However, it is not possible to record the contents that were set.

<Note>

The time code/user bits are also recorded in the VIDEO AUX area of the unit's memory. The time code (VITC) is the same value as the sub code area's time code (LTC). Special information such as the camera's frame rate is recorded in the user bits (VITC's user bits).

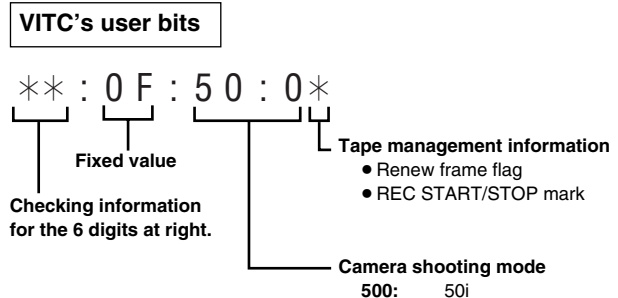

Chapter 4 Adjustments and settings for recording

4-5-2 Setting the internal clock's date and time

- 1 Set the DISPLAY switch to UB.
- 2 Press the HOLD button to cause DATE to be displayed in the display window.
- 3 Set the TCG switch to SET.
- 4 Set the date (year/month/day) using the SHIFT button, UP (+) button and DOWN (-) button.
- 5 Press the HOLD button to cause TIME to be displayed in the display window.
- 6 Set the time (hour/minutes/seconds) using the SHIFT button, UP (+) button and DOWN (-) button.
- 7 Set the TCG switch to F-RUN or R-RUN. The internal clock starts marking time as soon as the switch position is changed.
- 8 Press the HOLD button to cause TIME ZONE (difference from the world standard time) to be displayed in the display window.
- 9 Set the TCG switch to SET.
- 10 Set the time difference (hour/minutes) and whether it is ahead (no display) or behind ("-" display) the world standard time using the UP (+) button or DOWN (-) button.
 Example: When the time difference is 5 hours behind (New York)
 Set "05:00 -".
 The time zone is always stored along with the date and time in the memory as memo data. While referring to the table on the right, set whatever applies to the local time.
- 11 Set the TCG switch to F-RUN or R-RUN to fix the time zone.

Time difference	Region	Time difference	Region
00:00	Greenwich	- 00:30	
- 01:00	Azores	- 01:30	
- 02:00	Mid-Atlantic	- 02:30	
- 03:00	Buenos Aires	- 03:30	New Foundland
- 04:00	Halifax	- 04:30	
- 05:00	New York	- 05:30	
- 06:00	Chicago	- 06:30	
- 07:00	Denver	- 07:30	
- 08:00	Los Angeles	- 08:30	
- 09:00	Alaska	- 09:30	Marquesas Islands
- 10:00	Hawaii	- 10:30	
- 11:00	Midway Island	- 11:30	
- 12:00	Kwajalein	+ 11:30	Norfolk Island
+ 13:00		+ 10:30	Lord Howe Island
+ 12:00	New Zealand	+ 09:30	Darwin
+ 11:00	Solomon Islands	+ 08:30	
+ 10:00	Guam	+ 07:30	
+ 09:00	Tokyo	+ 06:30	Rangoon
+ 08:00	Beijing	+ 05:30	Bombay
+ 07:00	Bangkok	+ 04:30	Kabul
+ 06:00	Dhaka	+ 03:30	Tehran
+ 05:00	Islamabad	+ 02:30	
+ 04:00	Abu Dhabi	+ 01:30	
+ 03:00	Moscow	+ 00:30	
+ 02:00	Eastern Europe	+ 12:45	Chatham Island
+ 01:00	Central Europe		

<Notes>

- After the date has been set in step 4, the internal clock starts marking the time as soon as the switch position has been changed even when the TCG switch is set to F-RUN or R-RUN.
 To cancel the setting in the course of setting the date, time or time zone, set the TCG switch to F-RUN or R-RUN while holding down the SHIFT button.
- The clock is accurate to a monthly error of approximately +/- 30 seconds in the power OFF status. If a more accurate time reading is required, check the time and set it again when the power is turned on.
 When the AJ-GPS900G GPS unit is installed and the time can be received, the internal clock's time (local date/time) is kept accurate on the basis of the received time (world standard time) and time zone. If the date or time display has deviated from the local time, the time zone setting may be off. Check the time zone setting again. (There is no need to set the date and time again.)

Chapter 4 Adjustments and settings for recording

4-5-3 Setting the time code

- 1 Set the DISPLAY switch to TC.
- 2 Set the TCG switch to SET.
- 3 Set the time code using the SHIFT button, UP (+) button and DOWN (-) button.
- 4 Select the TCG switch position.
Select "F-RUN" to advance the time code in the free-run mode or select "R-RUN" to advance it in the rec-run mode.

Time code when the battery is replaced

The backup function works even when the battery is replaced, and the time code generator continues to operate for a prolonged duration (approx. 1 year).

<Note>

If the POWER switch is turned on, then off, and then on again, the free-run time code backup accuracy is approximately ± 2 frames.

4-5-4 Externally locking the time code

The unit's internal time code generator can be locked to an external generator. In addition, the time code generator of an external VTR can be locked to the unit's internal generator.

Example of connections for external locking

As the figure shows, connect both the reference video signal and reference time code.

Example 1: When locking onto an external signal

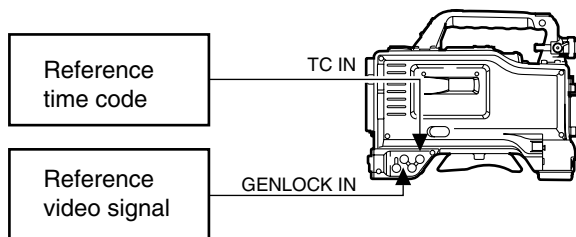

Example 2: When connecting a multiple number of units and using one of them as the reference unit

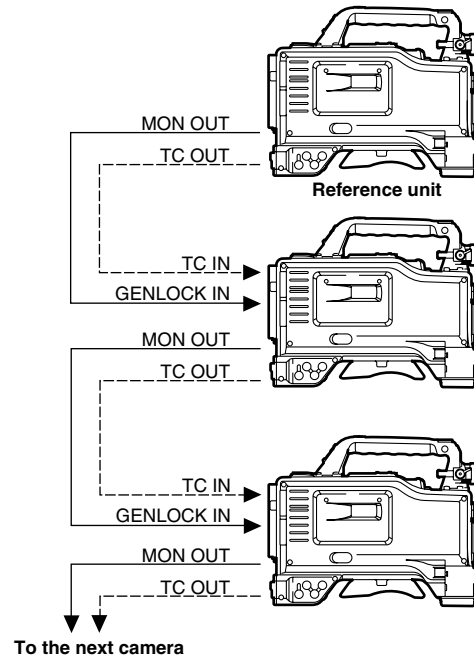

Operating procedure for external locking

Follow the steps below for external locking.

- 1 Set the POWER switch to ON.
- 2 Set the TCG switch to F-RUN.
- 3 Set the DISPLAY switch to TC.
- 4 Supply the reference time code and reference video signal, which are in a phase relationship that satisfies the time code standard, to the TC IN connector and GENLOCK IN connector respectively.

The built-in time code generator is now locked to the reference time code.

About 10 seconds after locking, the external lock status will be retained even if the connection of the externally supplied reference time code is disconnected. However, the servo lock will be subject to disturbances if it is connected or disconnected during recording.

<Notes>

- When the external lock operation is performed, the time code is instantly locked to the external time code, and the same value as the external code value appears on the counter display. Do not set the unit to the recording mode during the few seconds it takes for the sync generator to stabilize.
- The images may be disrupted during the instant when external locking is performed. This happens because the 5-frame period is adjusted, and it does not mean that the unit is malfunctioning.
- When 1394 is selected as the REC SIGNAL menu item setting, the unit cannot be gen-locked with the time code which is input to the TC IN connector.

Chapter 4 Adjustments and settings for recording

Concerning the user bit setting during external lock

When the unit's time code is externally locked, only the time data is locked to the time data of the time code supplied from the external source. This means that the user bits can be set separately for each component.

When the <TC/UB> screen is opened from the VTR menu page and EXT is selected as the UB MODE item setting by performing menu operations, the user bits can also be locked to the user bits of the time code supplied from the external source.

To release the external lock

First stop supplying the external time code, and set the TCG switch to R-RUN.

When switching the power from the battery to an external power supply while the time code is externally locked

In order to ensure the continuity of the time code generator's power, connect the external power supply to the DC IN connector, and then remove the battery pack. If the battery pack is removed first, no guarantees can be made for the continuity of the external locking of the time code.

Gen-locking of the camera unit while the time code is externally locked

While the time code is externally locked, the camera unit is gen-locked by the reference video signal which is supplied to the GEN LOCK IN connector.

<Notes>

- When locking the external time code to a multiple number of units with this unit serving as the master, the same mode as the unit's camera mode must be set. Bear in mind that no guarantees can be made for the continuity of the images and time code if both the interlace and progressive formats are used together in the system.
- When the signal from the unit's MON OUT connector is to be used as the reference video signal, first set the OUTPUT SEL switch on the side panel to the CAM position.
- The unit cannot be gen-locked with an external signal when the <GENLOCK> screen is opened from the SYSTEM SETTING page by performing menu operations and INT is selected as the GENLOCK menu item setting.

4-5-5 Setting the UMID information

This unit supports metadata UMIDs. As the UMID data, the user must first set the name of his or her country (with 3 or fewer characters), the name of the company or organization (with 4 or fewer characters), and the user name (with 4 or fewer characters). Input the name of the country based on the Country Codes (*1) stipulated under the ISO 3166 standard. Given here as an example is the procedure for inputting the user name.

*1 Examples:

CHN for China, USA for United States, CAN for Canada, and JPN for Japan

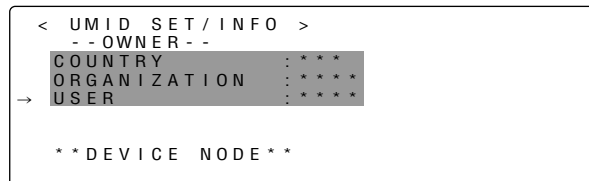

- 1 Open the <UMID SET/INFO> screen from the VTR menu page by performing a menu operation.
- 2 Turn the JOG dial button to move the arrow (cursor) to the "USER" item.
- 3 When the JOG dial button is pressed, the arrow (cursor) moves to the USER input area, and the input mode is established.
- 4 Press the JOG dial button again and turn it until the character to be set is displayed. When the button is turned, the character displayed is switched in the following sequence:
 - Space:
 - ↓
 - letters: A—Z
 - ↓
 - numbers: 0—9
 - ↓
 - symbols: ', >, <, /, -
- <Note>
Only spaces and letters can be selected for the COUNTRY item. This does not apply to other items.
- 5 Press the JOG dial button to enter the character.
- 6 Turn the JOG dial button to move the arrow (cursor) to the next position (right), and repeat steps 4 and 5 to set the characters.
- 7 When the characters have been input, turn the JOG dial button to move the arrow (cursor) to the ":" position.
- 8 When the JOG dial button is pressed, the arrow (cursor) returns to the "USER" item.
- 9 Press the MENU button to exit the menu operations.

Chapter 4 Adjustments and settings for recording

4-6 Menu displays on the viewfinder screen

4-6-1 Menu configuration

USER MENU: Although USER MENU is set at the factory, the user may perform menu operations to open the <USER MENU SELECT> screen from the MAIN MENU page, select the settings for its items in accordance with the purpose of operation and setting frequency and configure a menu tailored to individual needs. This menu appears when the MENU button is pressed.

MAIN MENU: This enables all the items on the setting menus to be set. It can be organized hierarchically by category in accordance with the purpose of operation and setting frequency. It appears when the MENU button is pressed for 3 or more seconds.

OPTION MENU: This menu is provided to accommodate the functions that may be added in the future. It appears when the MENU button is pressed while the LIGHT button is held down. For details, contact your nearest service center or your dealer.

4-6-2 Basic menu operations

Menu items are selected and entered using the MENU button and JOG dial button. The menus have a hierarchical configuration consisting of the main menu, sub menus and setting item menus.

The data which has been set is written and saved in a non-volatile memory.

The operations performed for the MAIN MENU are described here but the operating procedure is the same for the other menus as well except for the screen displays.

I Press the MENU button for 3 or more seconds. The menu screen consisting of items organized on a category by category basis now appears.

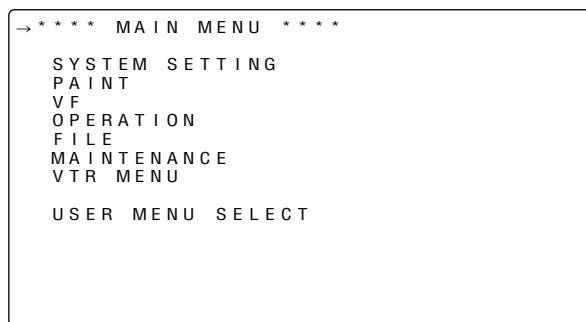

PAINT:

This item is used when detailed image adjustments are to be made while a waveform monitor is used to monitor the camera's output waveforms. Video engineer support is normally required for this. The items under this sub menu can also be set using an external remote control unit, but they are valid only when the unit is used on its own.

VF:

This item is used for selecting what is to be displayed on the viewfinder screen.

OPERATION:

This item is used to change settings in accordance with the subject conditions and other factors, usually when the unit is operated by the cameraman.

FILE:

This item is used to read and write the setup card data and perform the lens file and other file-related operations.

MAINTENANCE:

This item is used to perform the maintenance and inspections related to this unit's camera unit.

VTR MENU:

This item is used to perform the maintenance and inspections related to this unit's VTR unit.

USER MENU SELECT:

This item is used for editing the USER MENU.

SYSTEM SETTING:

This item is used when deciding on the unit's recording signals, recording system, etc.

Chapter 4 Adjustments and settings for recording

- 2 Turn the JOG dial button to move the arrow (cursor) to the item which is to be set, and the sub menu screen appears when the JOG dial button is pressed.

```
**** MAIN MENU ****
SYSTEM SETTING
PAINT
VF
→ OPERATION
FILE
MAINTENANCE
VTR MENU
USER MENU SELECT
```

- 3 Turn the JOG dial button to move the arrow (cursor) to the item which is to be set, and the setting item menu screen appears when the JOG dial button is pressed.

```
< OPERATION >
CAMERA ID
SHUTTER SPEED
SHUTTER SELECT
→ USER SW
SW MODE
WHITE BALANCE MODE
USER SW GAIN
IRIS
```

- 4 Turn the JOG dial button to move the arrow (cursor) to the item which is to be set, and the item's setting flashes when the JOG dial button is pressed.

```
< USER SW >
→ USER MAIN SW :S.GAIN*
USER1 SW :0.ZOOM
USER2 SW :DS.GAIN
```

- 5 Turn the JOG dial button to change the setting.

To increment the value

Turn the JOG dial button in the clockwise direction as viewed from the front of the camera.

To decrement the value

Turn the JOG dial button in the counterclockwise direction as viewed from the front of the camera.

Each time the button is turned, the number changes by one increment. When it is turned quickly, the number changes quickly, and when it is turned slowly, the setting can be adjusted finely.

To set an item to ON or OFF

To set an item to ON, turn the JOG dial button in the clockwise direction as viewed from the front of the camera. Conversely, to set an item to OFF, turn the button in the counterclockwise direction as viewed from the front of the camera.

- 6 Press the JOG dial button.
The setting stops flashing, and the setting is entered.
- 7 To change another setting item on the same page, repeat steps 4 to 6.
- 8 Press the MENU button to exit the menu operations.
The menu setting mode is exited, and operation returns to the normal operation mode.

4-6-3 Selecting the user menus

By performing menu operations, open the USER MENU SELECT page from the MAIN MENU and then open the setting item menu screens, and select only those items required on the USER MENU.

Only the items which have been set are displayed as the USER MENU items. For details on operation, refer to "4-6-2 Basic menu operations."

```
< USER MENU SELECT > (SELECT MODE)
→ SYSTEM
PAINT
VF
OPERATION
FILE
MAINTENANCE
VTR
```

<Note>

Setting items are effective when "*" is displayed. However, the maximum number of items that can be set is 42 in the case of camera related items (3 pages' worth, with 14 items per page, $14 \times 3 = 42$) or 14 in the case of VTR related items (1 page's worth, or 14 items).

Chapter 4 Adjustments and settings for recording

4-7 Viewfinder screen status displays

Not only the images but the lamps and characters indicating the unit's settings and operation statuses as well as the messages, center and safety zone markers, camera ID and other information are displayed inside the viewfinder.

4-7-1 Viewfinder lamp displays

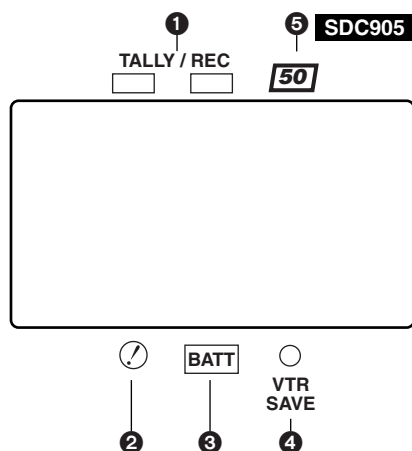

Viewfinder pictured here is the AJ-VF20WB. (For details concerning viewfinder, refer to the operating instructions of each viewfinder.)

1 TALLY/REC (recording) lamp

This lights up (red) during recording. It flashes when a problem has occurred. For details, refer to the appropriate section in "6-3 Warning system."

2 (abnormal operating status warning) lamp

This lights when the unit is set to an abnormal operating status for any of the items set to "ON" on the "ILED" screen of the setting menu.

For details on selecting the items which are to be indicated with the (abnormal operating status warning) lamp, refer to the <ILED> screen items in "Chapter 7 Menu description tables."

3 BATT (battery) lamp

This starts flashing when the battery voltage has dropped to the level where the battery will no longer be usable in several minutes' time, and it lights when the battery is no longer usable. To prevent operation from being interrupted, replace the battery before it has discharged completely. For details, refer to the appropriate section in "6-3 Warning system."

4 VTR SAVE (VTR power-saving) lamp

This lights when the VTR SAVE/STBY switch is set to SAVE. It goes off during recording.

<Note>

In the rec-pause mode, the SAVE mode is established automatically, and the lamp lights after the time set for the pause timer (temporary stop time) has elapsed.

After two minutes in the play-pause mode, the SAVE mode is established automatically, and the lamp lights.

5 50 (50 Mbps recording/playback) lamp SDC905

This lights when a tape is being played back at 50 Mbps while the mode for recording or playback at 50 Mbps is selected.

4-7-2 Viewfinder screen status display configuration

All the items that can be displayed are laid out inside the viewfinder as shown in the figure below.

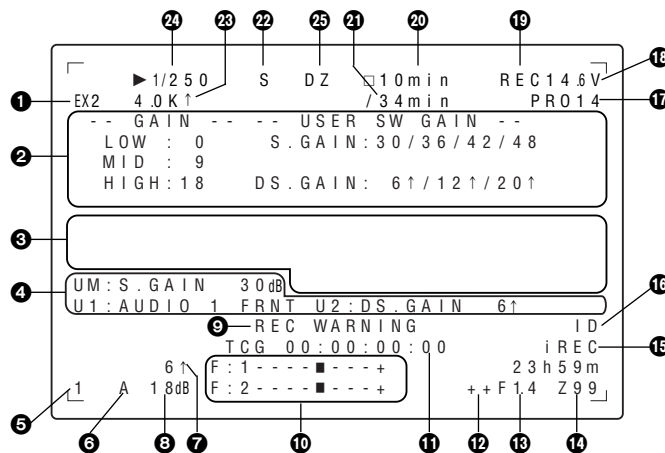

For details, refer to the following pages.

4-7-3 Selecting the viewfinder screen display items

To select which items are to be displayed on the viewfinder screen, perform menu operations to open the <VF INDICATOR1> screen or <VF INDICATOR2> screen from the VF page, and select ON or OFF for the display or select the type desired for each item concerned.

For details on operation, refer to "4-6-2 Basic menu operations."

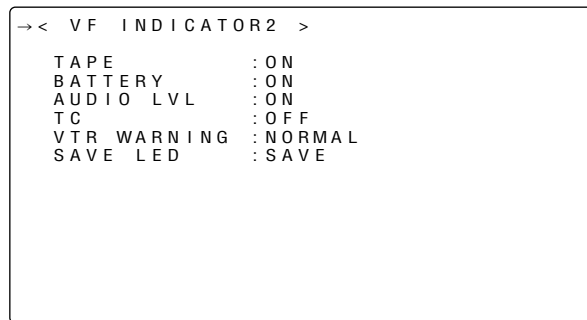
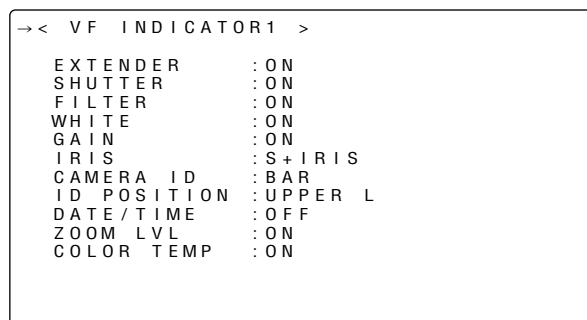

Chapter 4 Adjustments and settings for recording

Display item	What is displayed	Status when display appears
① Extender	EX2	This appears when the lens extender is in use.
② MODE CHECK dedicated display area (STATUS: master gain, user switch gain)	LOW/MID/HIGH -3 to 30 S.GAIN30/36/42/48 DS.GAIN6 ↑ /12 ↑ /20 ↑	This indicates the master gain setting. Example: LOW = 0 When S.GAIN and DS.GAIN functions have been allocated to the user switches, the corresponding gain values are displayed. The user switch displays do not appear unless the S.GAIN and DS.GAIN functions have been allocated.
(Causes for ! LED to light: Displayed on the entire screen.) • An exclamation mark (!) appears next to items selected on the ! LED menu. • An exclamation mark (!) appears next to items for which the ! LED lights.	GAIN (0 dB) GAIN (-3 dB) DS.GAIN SHUTTER WHITE PRE. EXTENDER BLACK STR. MATRIX COLOR COR. FILTER SUPER V 25M/50M SDC905 ATW D.ZOOM	This indicates the current GAIN status. This indicates the current GAIN status. This indicates the current DS.GAIN value. This indicates the current shutter status. This indicates the current WHITE BAL status. This indicates whether the current extender setting is on EX2 or OFF. This indicates whether the current black stretch setting is ON or OFF. This indicates whether the current MATRIX setting is A, B or OFF. This indicates whether the current COLOR CORRECTION setting is ON or OFF. This indicates the current filter status. This indicates whether the current SUPER V setting is ON or OFF. This indicates whether the current memory mode setting is 25M or 50M. This indicates whether the current ATW setting is ON or OFF. This indicates whether the current digital zoom setting is ON or OFF.
(FUNCTION: VIDEO OUT)	SW: VTR/CAM/OFF SELECT: VBS/VF/Y CHAR: ON/OFF	This indicates the position of the OUTPUT SEL switch. This indicates the setting status of the VIDEO OUT SEL menu. This indicates the position of the VIDEO OUT CHARACTER switch.
(FUNCTION: MONI OUT)	SW: VTR/CAM/OFF CHAR: ON/OFF	This indicates the setting status of the VIDEO OUT SEL menu. This indicates the setting status of the MONITOR OUT CHAR menu.
(AUDIO: front controls enable/disable)	CH1: ON/OFF CH2: ON/OFF	ON appears if the front CH1 control is enabled and OFF appears if it is disabled. ON appears if the front CH2 control is enabled and OFF appears if it is disabled.
(AUDIO: microphone power status)	FRONT: ON/OFF REAR: ON/OFF	This indicates the status of the front microphone's power. This indicates the menu setting status for the rear microphone's power.
(AUDIO: channel input signals and levels)	FRONT/W.L./REAR CH1/2	This indicates the input signals and levels for the individual channels.
③ Camera warning and message display area (Displays related to the AWB, ABB and switch operations)	AWB A ACTIVE AWB B ACTIVE AWB A OK *.*K AWB B OK *.*K AWB BREAK *.*K AWB NG COLOR TEMP LOW COLOR TEMP HIGH LEVEL OVER LOW LIGHT TIME OVER AWB PRESET *.*K ATW MODE CHECK FILTER AWB A VAR *.*K AWB B VAR *.*K	This appears during an AWB operation for channel A. This appears during an AWB operation for channel B. This appears when the AWB operation has been completed satisfactorily for channel A. This appears when the AWB operation has been completed satisfactorily for channel B. This appears when the AWB operation has been forcibly terminated. This appears when the AWB operation has not been completed satisfactorily. The status is indicated on the second line. This warns the user that the color temperature is too low. This warns the user that the color temperature is too high. This warns the user that the brightness is too high. This warns the user that the brightness is too low. This warns the user that the processing could not be executed within the operation time. This appears when the AWB switch has been set to PRE and AWB cannot be performed. This indicates that AWB cannot be executed during an ATW operation. This warns the user to recheck the position of the filter selector control during the AWB operation. This indicates that channel A is set to VAR and AWB operation is not possible. This indicates that channel B is set to VAR and AWB operation is not possible.

Chapter 4 Adjustments and settings for recording

Display item	What is displayed	Status when display appears
3 Camera warning and message display area (Displays related to the AWB, ABB and switch operations)	ABB ACTIVE ABB OK ABB BREAK ABB NG W-SHD ACTIVE W-SHD OK W-SHD BREAK W-SHD NG LVL OVER B-SHD READY B-SHD ACTIVE B-SHD OK B-SHD BREAK B-SHD NG B-SHD LVL OVER	This appears during an ABB operation. This appears when the ABB operation has been completed satisfactorily. This appears when the ABB operation has been forcibly terminated. This appears when the ABB operation has not been completed satisfactorily. This appears during a WHITE SHADING operation. This appears when the WHITE SHADING operation has been completed satisfactorily. This appears when the WHITE SHADING operation has been forcibly terminated. This indicates that white shading has not been completed satisfactorily as the brightness level was excessively high during the WHITE SHADING operation. This appears when the BLACK SHADING operation is ready to be performed as a result of holding down the ABB switch for a length of time during an ABB operation. This appears during a BLACK SHADING operation. This appears when the BLACK SHADING operation has been completed satisfactorily. This appears when the BLACK SHADING operation has been forcibly terminated. This appears when the BLACK SHADING operation has been not completed satisfactorily. This warns the user that the brightness is too high during the BLACK SHADING operation.
(Switch selection displays)	WHITE: # *. *K AUTO KNEE: ON/OFF GAIN: **dB SS: 1/***** SS: ► 1/***** SS: SUPER V FILTER: * *. *K EXTENDER: ON/OFF IRIS: ** F * *	This appears when the position of the WHITE BAL switch has been changed. "A," "B" or "PRE" appears at #. VAR *. * K is displayed when channel A, Y is set to VAR. ATW MODE is displayed when ATW is assigned to channel B. This appears when the AUTO KNEE switch has been set to ON or OFF. This appears when the gain has been selected using the GAIN selector switch or USER button. This indicates the shutter speed value when the shutter speed has been selected. This appears when synchro scan has been selected as the shutter speed. This appears when SUPER V has been selected as the shutter speed. This appears when the filter setting has been selected. This appears when the lens extender has been set to ON or OFF. This appears when the iris overwrite correction value has been changed.
(LOW LIGHT warning display)	LOW LIGHT	This appears when the brightness has dropped.
(Y GET value)	***. *%	With the Y GET ON setting, the output brightness level near the center marker is displayed as "%."
(CALL display)	CALL	This appears when the call command has been issued from the extender.
(MARKER display)	MKR: A/B/OFF	This indicates the type of marker presently being displayed.
4 Information allocated to USER buttons UM: USER MAIN U1: USER1 button U2: USER2 button	INH S.GAIN **dB/OFF DS.GAIN ** ↑ /OFF S.IRIS ON/OFF I.OVR ON/OFF S.BLK -** /OFF B.STR ON/OFF AUDIO CH1 AUDIO CH2	"INH" is indicated when the operation of the USER button has been disabled. This indicates the value selected for S.GAIN. This indicates the value selected for DS.GAIN. This indicates whether S.IRIS is set to ON or OFF. This appears when the IRIS OVERRIDE setting is enabled (ON). This indicates whether SUPER BLACK is set to ON or OFF and, if it is set to ON, it also indicates its value. This indicates whether BLACK STRETCH (black level gradation compensation) is set to ON or OFF. This appears when the input signal to recorded on audio channel 1 has been switched. This appears when the input signal to recorded on audio channel 2 has been switched.

Chapter 4 Adjustments and settings for recording

Display item	What is displayed	Status when display appears
④ Information allocated to USER buttons UM: USER MAIN U1: USER1 button U2: USER2 button	REC SW Y GET ON RET SW ATW ON/OFF D.ZOOM ON/OFF	This appears only during MODE CHECK button operations while the USER button functions as the REC switch. This appears when the function for measuring the output brightness level (in % units for approx. 3 seconds for the area near the center marker) is ON. This appears only during MODE CHECK button operations while the USER button functions as the RET switch. This appears when ATW is operating. This indicates whether D.ZOOM is set to ON or OFF.
⑤ Filter positions	1 to 4 –	This indicates the position of the filter. This indicates that the filter has not been set to a proper position.
⑥ WHITE BAL switch position	A B P T	This indicates that the WHITE BAL switch is set to channel A. This indicates that the WHITE BAL switch is set to channel B. This indicates that the WHITE BAL switch is set to PRE. This indicates that the ATW mode has not been set. It flashes when the brightness and color are outside the operating range.
⑦ Cumulative gain display	6 ↑ /12 ↑ /20 ↑	This indicates the value of the cumulative gain (DS.GAIN) when this gain function is working.
⑧ Gain value	**dB	This indicates the current gain value.
⑨ VTR warnings, information	REC WARNING SLACK E-*** HUMID SERVO RF 1394 BACKUP BATT EMPTY WIRELESS-RF	This indicates that a problem has occurred during recording. This indicates that a problem has occurred in a mechanism. Depending on the nature of the trouble concerned, the power may be turned off automatically. This indicates that condensation has formed. This indicates that servo lock has not been initiated during recording or playback. This indicates that the level of the signals from the tape has dropped. This indicates that there is something wrong with the signals supplied to the DVCPRO connector. This signals that it is time to replace the backup battery. This indicates that the level of the RF signal from the wireless microphone receiver has dropped. <Note> For details on the codes displayed in this area, refer to “6-3-2 Error codes.”
⑩ AUDIO input system and level meter	- - - - ■ - - - + F W R	This indicates the audio channels selected and their audio levels. This appears when the AUDIO IN switch is at the FRONT position. This appears when the AUDIO IN switch is at the WIRELESS position. This appears when the AUDIO IN switch is at the REAR position.
⑪ Time code display	TCG 12:59:59:20 TCR 12:59:59:20 (V)UBG AB CD EF 00 (V)UBR 12 34 56 78 CTL -01:59:59:20	This indicates the TCG (time code generator) value. This indicates the TCR (time code reader) value. This indicates the UBG VUBG display. This indicates the UBR VUBR display. This indicates the CTL-COUNTER value.
⑫ Iris override display	++ + (No display) – --	When the iris override function is working, this indicates how much compensation is provided. ++: The aperture is opened by a full stop. +: The aperture is opened by a half stop. – -: The aperture is closed by a full stop. –: The aperture is closed by a half stop. No display: Reference status
⑬ Iris, f-value	NC OPEN F1.7 to F16 CLOSE	This appears when the lens cable is not connected. This appears when the lens aperture is open. This indicates the aperture value (f-value) of the lens. This appears when the lens aperture is closed. <Note> These displays appear when using a lens equipped with an aperture value display function. They flash while the aperture is being changed for the iris override.

Chapter 4 Adjustments and settings for recording

Display item	What is displayed	Status when display appears
14 Zoom display	Z00 to Z99	This indicates the amount of zoom. Note that this item is not displayed even if the display setting is ON if the lens is not equipped with a zoom position return function.
15 Interval, pre-rec display	i (flashing) iREC (lighting) iREC (flashing) **h**m/**s P-REC (flashing) *s	This appears in the INTERVAL REC mode during the times when the operation of the REC button is not acknowledged before the start of or at the end of recording. This appears during an INTERVAL REC operation. This appears during INTERVAL REC standby to indicate the wait time until the next recording. This indicates the amount of time remaining until the end of the set PRE REC time during PRE REC operation.
16 ID recording display	ID	This appears when the setting to superimpose the ID onto the camera image and record the image with the ID has been established.
17 Battery type	PRO14 to AC-ADPT	This indicates the type of battery selected on the menu. "AC ADPT" appears when an AC adapter has been input.
18 Remaining battery charge/voltage	**.*V ***% EMP MAX	This indicates the remaining battery charge in 0.1V increments. This indicates the remaining digital battery charge in percent. This appears when the battery has no charge left. This appears when the battery has a full charge.
19 Unit's REC display	REC	This appears when the extender unit and 26-pin connector (BOTH) have been connected to indicate the unit's recording status using characters. It lights during recording, and it flashes while the unit's mode is transferring to recording or when a warning has been issued.
20 Remaining tape	***min END INH	Under normal conditions, "***min" lights, and this starts flashing while the tape is reaching the end. When the tape has reached the end, "END" lights. When recording has been inhibited, "INH" lights.
21 Total length of cassette tape	***min	This indicates the total length of the cassette tape. (This appears during a mode check.)
22 Super iris ON/ super black ON	S B SB	This appears when S.IRIS has been set to ON. This appears when S.BLK has been set to ON. This indicates the color temperature during the AWB operation.
23 Color temperature	*.*K	This indicates the color temperatures assigned to the A, B, and PRE positions of the WHITE BAL switch. (These may be memory values during AWB operation or menu setting values.) This indication does not appear in the ATW MODE.
24 Shutter speed/mode	▶1/**.* 1/60 - 1/2000 SUPER V	This indicates that the shutter speed is set to SYNCHRO SCAN. This indicates that a fixed shutter speed has been set. This appears when the SUPER V (mode with high vertical resolution) has been set.
25 D.ZOOM	DZ	This appears when the D.ZOOM mode has been established.

Chapter 4 Adjustments and settings for recording

Viewfinder screen display selection

	Whether a display is to be shown or not can be selected on a menu.	Status displayed when established	Displayed only by MODE CHECK button (*1)	Display can be cleared	Displayed during playback
① Extender	○	○	●	○	-
② MODE CHECK dedicated display area	-	-	○	○	-
③ Camera warning, message display area	-	○	○	○	-
④ Information allocated to USER buttons	-	○	○	○	-
⑤ Filter positions	○	-	●	○	-
⑥ WHITE BAL switch position	○	-	●	○	-
⑦ Cumulative gain display	○	-	●	○	-
⑧ Gain value	○	-	●	○	-
⑨ VTR warnings, information	○	○	●	○	-
⑩ AUDIO input system and level meter	○	-	All input information for 2 channels	○	-
⑪ Time code display	○	-	●	○	○(dependent upon menu)
⑫ Iris override display	○	○	●	○	-
⑬ Iris, f-value	○	-	●	○	-
⑭ Zoom display	○	-	●	○	-
⑮ Interval, pre-rec display	-	○	●	○	-
⑯ ID recording display	-	○	●	-	-
⑰ Battery type	-	-	●	○	-
⑱ Remaining battery charge/voltage	○	-	●	○	-
⑲ Unit's REC display	○	○	●	○	-
⑳ Remaining tape	○	-	●	○	-
㉑ Total length of cassette tape	-	-	●	○	-
㉒ Super iris ON/super black ON	○	○	●	○	-
㉓ color temperature	○	○	●	○	-
㉔ Shutter speed/mode	○	○	●	○	-
㉕ D.ZOOM	-	○	●	○	-

*1 ○: The display does not appear when OFF has been selected for the STATUS item setting on the <MODE CHK IND> screen.

●: Display always appears regardless of the menu.

Chapter 4 Adjustments and settings for recording

4-7-4 Display modes and setting changes/adjustment result messages

By setting the display mode item, it is possible to select various display methods for the changes made in the settings and for the messages advising the user of the adjustment results: for instance, the items displayed can be limited to a select number or not displayed at all. To select the display mode, perform menu operations to open the <VF DISPLAY> screen from the VF page and select the setting for the DISP MODE item.

For details on operation, refer to “4-6-2 Basic menu operations.”

```

->< VF DISPLAY >
DISP CONDITION      : NORMAL
DISP MODE           : 3
VF OUT              : Y
VF DTL              : 3
ZEBRA1 DETECT       : 070%
ZEBRA2 DETECT       : 085%
ZEBRA2              : SPOT
LOW LIGHT LVL       : 35%
ECU MENU DISP       : OFF
50M INDICATOR       : OFF
MARKER / CHAR LVL   : 50%
    
```

Setting change/adjustment result messages and display modes

Situation in which message is displayed	Message	Display mode setting		
		1	2	3
When the filter selection has been changed	FILTER: n (n=1, 2, 3, 4)	x	x	○
When the gain setting has been changed	GAIN: n dB (n= -3, 0, 3, 6, 9, 12, 15, 18, 21, 24, 27, 30)	x	x	○
When the WHITE BAL switch setting has been changed	WHITE: n (n=ACH, BCH, PRESET)	x	x	○
When the OUTPUT/AUTO KNEE switch has been set to AUTO KNEE or OFF	AUTO KNEE: ON (or OFF)	x	○	○
When the shutter speed/mode setting has been changed	SS: 1/60 (or 1/120, 1/250, 1/500, 1/1000, 1/2000, S.SCAN)	x	○	○
When the white balance (AWB) has been adjusted	Example) AWB A OK 3.2K	x	○	○
When the black balance (ABB) has been adjusted	Example) ABB OK	x	○	○
When the extender has been selected	Example) EXTENDER ON	x	x	○
When a user button has been selected	Example) UM: S.GAIN 30 dB	x	○	○
When a marker select button has been selected	Example) MKR: A	x	x	○
When in iris overwrite status	Example) ++ F 5.6	x	○	○

○: Message is to be displayed.
x: Message is not to be displayed.

4-7-5 Setting the marker displays

ON, OFF or the display type can be selected for the displays of the center marker, safety zone markers, safety zone area and frame marker. To make the selection, perform menu operations to open the <VF MARKER> screen from the VF page and select the display mode for each item.

For details on operation, refer to “4-6-2 Basic menu operations.”

```

->< VF MARKER >
TABLE           : A
CENTER MARK     : 1
SAFETY ZONE     : 2
SAFETY AREA     : 90%
FRAME SIG       : 4 : 3
FRAME MARK     : OFF
FLAME LVL       : 15
MKR : A
    
```

<Note>

The MKR: A indication at the upper right of the screen shows the display status. To check the settings for TABLE B, press the MARKER SELECT so that MKR:B is displayed.

4-7-6 Setting the camera ID

The camera ID is set on the CAMERA ID screen. Up to ten alphanumeric, symbols and spaces can be used.

<Note>

The camera ID is not displayed while the setting menu is displayed even if color bar signals are output.

1 Perform a menu operation to open the <CAMERA ID> screen from the OPERATION page.

```

->< CAMERA ID >
ID1 : ABCDEFGHIJ
ID2 : ABCDEFGHIJ
ID3 : ABCDEFGHIJ
    
```

2 Turn the JOG dial button to move the arrow (cursor) to the “ID 1: to 3:” item.

Chapter 4 Adjustments and settings for recording

3 When the JOG dial button is pressed, the arrow (cursor) moves to the ID input area, and the input mode is established.

4 Press the JOG dial button again and turn it until the character to be set is displayed.
When the button is turned, the character displayed is switched in the following sequence:

- Space: □
- ↓
- letters: A—Z
- ↓
- numbers: 0—9
- ↓
- symbols: ', >, <, /, -

5 Press the JOG dial button to enter the character.

6 Turn the JOG dial button to move the arrow (cursor) to the next position (right), and repeat steps 4 and 5 to set the characters.

7 When the characters have been input, turn the JOG dial button to move the arrow (cursor) to the “:” position.

8 When the JOG dial button is pressed, the arrow (cursor) returns to the ID 1:, ID 2: or ID 3: item.

9 Press the MENU button to exit the menu operations.
The setting menu is cleared, and the displays showing the unit’s current statuses appear at the top and bottom of the viewfinder screen.

<Note>

The camera ID is recorded at the same time as the color bar signals if “CAMERA ID” on the VF INDICATOR screen has been set to “BAR.”

4-7-7 Mode check screen displays (MODE CHECK button function)

The screens enabling the unit’s settings and modes to be checked can be displayed in the viewfinder.

Each time the unit’s MODE CHECK button is pressed, one of the four screen displays is selected in the following sequence: STATUS screen display → ILED screen display → FUNCTION screen display → AUDIO screen display.

Each screen is displayed for about 3 seconds. When the MODE CHECK button is pressed while one screen is displayed, the next screen is displayed.

To select whether to display the screens, perform menu operations to open the <MODE CHECK IND> screen from the VF page and select ON or OFF for each screen display.

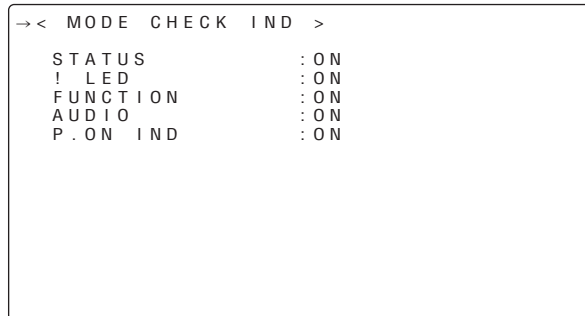

4-7-8 Marker check screen displays (MARKER SELECT button function)

The screens enabling the unit’s marker statuses to be checked can be displayed in the viewfinder.

Each time the unit’s MARKER SELECT button is pressed, one or none of the two screen displays is selected in the following sequence: A marker screen display → B marker screen display → no display.

When the MARKER SELECT button is pressed while one screen is displayed, the next screen is displayed. Before this, perform menu operations to open the <VF MARKER> screen from the VF page, select A as the TABLE item setting, and select the marker information for the other items.

Next, select B as the TABLE item setting, and select the marker information for the other items.

If, for instance, “16:9” is selected for the FRAME SIG item as the A marker information and “4:3” is selected for the FRAME SIG item as the B marker information, then the 16:9 and 4:3 aspect ratios can be checked easily by operating the MARKER SELECT button as and when required.

4-7-9 Checking the return video signal on the viewfinder

The return video signal which has been input to the GENLOCK IN connector can be viewed in the viewfinder while the RET button on the lens is held down.

To activate this function, perform menu operations to open the <SW MODE> screen from the OPERATION page, and select CAM RET as the RET SW item setting.

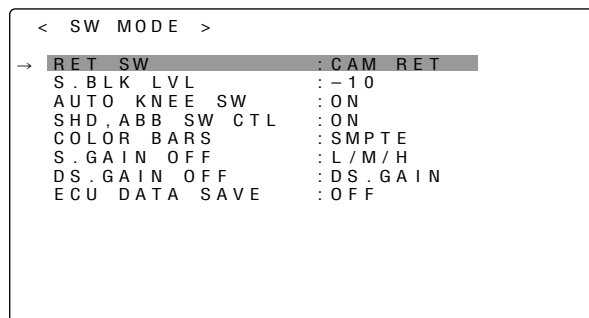

Chapter 4 Adjustments and settings for recording

4-8 Menu-driven function setup

The functions can be set up using the unit's menus.

4-8-1 Setting the USER SW GAIN switching

In addition to the standard gain settings of L, M and H, the S.GAIN (super gain) mode function that provides an analog gain increase of 30 dB or more and the DS.GAIN (digital super gain) mode function that provides a cumulative-type gain increase can be used with this unit.

To select these functions, perform menu operations to open the <USER SW GAIN> screen from the OPERATION page and select the gain settings to be used using the S.GAIN item and DS.GAIN item.

If, for instance, the S.GAIN and DS.GAIN functions have been allocated to the USER MAIN button, USER1 button or USER2 button, three different types of gain increases can be made by the combinations of the three USER buttons.

1) To increase the gain without increasing the perceptible noise

Combine the L, M or H value with the DS.GAIN function.

2) To increase the normal analog gain (in which case, the amount of noise will increase)

Use only the S.GAIN function.

3) To use the unit in the ultra-high-sensitivity mode

Use the S.GAIN function and DS.GAIN function in combination. (This enables an increase in gain of up to 68 dB.)

However, caution should be observed since the higher the DS.GAIN increase, the more noticeable the after image becomes with moving subjects.

Use a gain increase of up to +12 dB ↑ with moving subjects.

```

->< USER SW GAIN >

S . G A I N
* 3 0 d B
* 3 6 d B
* 4 2 d B
* 4 8 d B

D S . G A I N
* 6 d B ↑ ( 1 / 2 5 )
* 1 2 d B ↑ ( 1 / 1 2 )
* 2 0 d B ↑ ( 1 / 5 )
    
```

Setting items and details

S.GAIN: An analog gain increase with an asterisk is one that is valid. One without an asterisk is invalid.

DS.GAIN: A cumulative gain increase with an asterisk is one that is valid. One without an asterisk is invalid.

4-8-2 Selecting the video output signals

The signals which are output from the VIDEO OUT connector and MON OUT connector can be selected. To select this function, perform menu operations to open the <OUTPUT SEL> screen from the SYSTEM SETTING page, select the VIDEO OUT signal for the VIDEO OUT SEL item, select the type of characters to be superimposed onto the VIDEO OUT signal and MONITOR OUT signal for the OUTPUT CHAR item and MONITOR OUT CHAR item, and select whether or not the characters are to be superimposed onto the MONITOR OUT signal.

```

->< OUTPUT SEL >

V I D E O   O U T   S E L       : V B S
O U T P U T   C H A R         : M E N U   O N L Y
M O N I T O R   O U T   C H A R : O F F
V F   M O D E                 : E E / P B
    
```

Setting items and details

Item	Variable range	Remarks
VIDEO OUT SEL	VBS VF Y	For selecting the output signal of the VIDEO OUT connector. VBS: The normal composite signal is output. VF: The viewfinder's Y signal is output. The status display is also superimposed. Y: The component Y signal is output.
OUTPUT CHAR	TC STATUS MENU ONLY	For setting the type of characters to be superimposed onto the output signals of the VIDEO OUT connector and MON OUT connector. TC: The time code is displayed. (The menu appears when the menu is displayed.) <Note> The time code display position moves vertically in accordance with the camera ID position. STATUS: All the same characters as the ones superimposed on the viewfinder are displayed. (The menu appears when the menu is displayed.) MENU ONLY: Only appears when the menu is displayed. Normally, nothing is displayed
MONITOR OUT CHAR	ON OFF	For selecting whether characters are to be superimposed onto the MON OUT connector signals. (It is not linked with the VIDEO OUT CHARACTER switch.) The characters which are superimposed are the ones which are selected using the OUTPUT CHAR menu item. ON: The characters are superimposed. OFF: The characters are not superimposed.

Chapter 4 Adjustments and settings for recording

4-8-3 Selecting the F.AUDIO LEVEL control function

This function enables the recording level to be adjusted using the F.AUDIO LEVEL control.

To select this function, perform menu operations to open the <MIC/AUDIO> screen from the VTR MENU page, and set whether to enable or disable the F.AUDIO LEVEL controls for the system selected as the input signals using the FRONT VR CH1 and FRONT VR CH2 items.

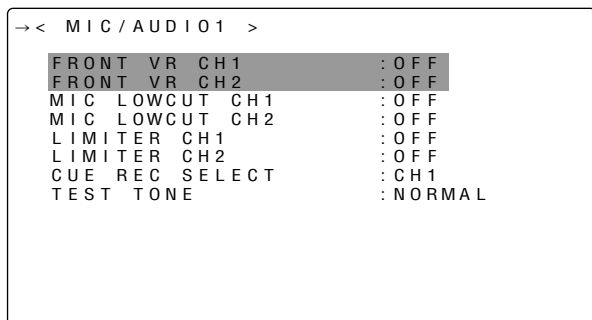

4-8-4 Allocating functions to the USER MAIN, USER1 and USER2 buttons

The desired functions can be allocated to the USER MAIN, USER1 and USER2 buttons.

To select this function, perform menu operations to open the <USER SW> screen from the OPERATION page, and set the desired function each with the USER MAIN SW item, USER1 SW item and USER2 SW item.

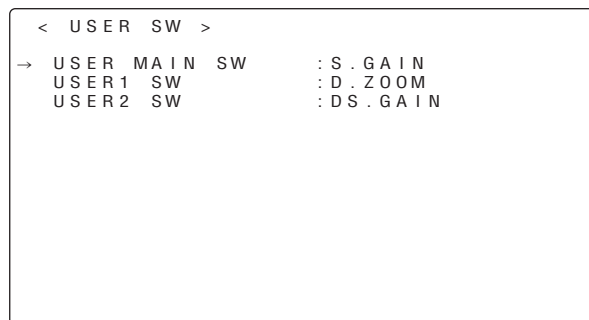

Setting items and what is set

Item	Variable range	Remarks
FRONT VR CH1	FRONT W.L REAR ALL OFF	For selecting whether or not to enable the F.AUDIO LEVEL control for the input signals which have been selected for audio CH1. FRONT: The control works only when FRONT has been selected. W.L.: The control works only when WIRELESS has been selected. REAR: The control works only when REAR has been selected. ALL: The control works regardless of which input has been selected. OFF: The control does not work regardless of which input has been selected. Even if it is rotated, the recording level will not change.
FRONT VR CH2	FRONT W.L REAR ALL OFF	For selecting whether or not to enable the F.AUDIO LEVEL control for the input signals which have been selected for audio CH2 FRONT: The control works only when FRONT has been selected. W.L.: The control works only when WIRELESS has been selected. REAR: The control works only when REAR has been selected. ALL: The control works regardless of which input has been selected. OFF: The control does not work regardless of which input has been selected. Even if it is rotated, the recording level will not change.

Functions which can be selected

INH:

No functions are allocated.

S.GAIN:

The S.GAIN function is allocated.

DS.GAIN:

The DS.GAIN function is allocated.

S.IRIS:

The SUPER IRIS function is allocated. This is useful when providing backlight compensation.

I.OVR:

The IRIS override function is allocated.

This changes the target (reference) value in the auto iris mode.

To change the target value, first establish this mode, and then press the JOG dial button to enable the target value to be changed. The target value is changed by turning the JOG dial button clockwise or counterclockwise. "+," "+ +," "-" or "- -" is displayed on the left of the iris display area on the viewfinder screen. Stop turning the JOG dial button at the position to be changed, and press the JOG dial button to enter the change in the target value.

The reference value is restored when this mode is released or the power is turned off.

+: The aperture is opened by a half stop.

+ +: The aperture is opened by a full stop.

-: The aperture is stopped down by a half stop.

- -: The aperture is stopped down by a full stop.

No display:

The reference value remains unchanged.

S.BLK:

The SUPER BLACK function is allocated. This function reduces the black level to below the pedestal level.

B.STR:

The BLACK stretch function is allocated. This function highlights the black gradations.

Chapter 4 Adjustments and settings for recording

UDIO CH1:

The function for switching the channel 1 input signal is allocated. Each press advances the setting through the sequence FRONT → W.L. → REAR. Note that it is also possible to change the setting by operating the AUDIO IN switch. Whichever control is operated last takes precedence.

AUDIO CH2:

The function for switching the channel 2 input signal is allocated. Each press advances the setting through the sequence FRONT → W.L. → REAR. Note that it is also possible to change the setting by operating the AUDIO IN switch. Whichever control is operated last takes precedence.

REC SW:

The function of the VTR's START button is allocated.

Y GET:

The function for displaying the brightness level of the center marker area is allocated.

RET SW:

The function of the RET button on the lens is allocated.

ATW:

The automatic tracking type of white balance function is allocated.

D.ZOOM:

The lens zooms in on the aspect ratio at double the width and height.

4-8-5 Setting the color temperature manually

The white balance can be adjusted manually using the color temperature settings. These manual color temperature settings can be performed for the PRST, A and B settings of the WHITE BAL switch.

Perform menu operations to open the <WHITE BALANCE MODE> screen from the OPERATION page, and select VAR as the setting for the AWB A item and AWB B item. The manual color temperature adjustment function is now valid. The color temperatures are set using the COLOR TEMP PRE item, COLOR TEMP A item and COLOR TEMP B item.

```
→< WHITE BALANCE MODE >
  FILTER INH       : ON
  SHOCKLESS AWB   : NORMAL
  AWB AREA        : 25%
  AWB&ABB OFFSET  : OFF

  COLOR TEMP PRE  : 3200K
  AWB A           : MEM
  COLOR TEMP A    : 3200K
  AWB B           : MEM
  COLOR TEMP B    : 3200K
  ATW SPEED       : NORMAL
```

4-9 Data handling

Setup card

Use of the setup memory card (optional accessory) enables the setting menu contents to be saved. Use of this data speeds up the process of reproducing suitable setup statuses.

- Multimedia cards or SD memory cards can be used as the setup cards.

4-9-1 Handling the setup card

The setup card can be inserted or removed before or after the power is switched on.

Inserting the setup card

Open the switch cover, position the setup card (optional accessory) with its cutout facing up, insert it into the setup card insertion slot, and close the switch cover.

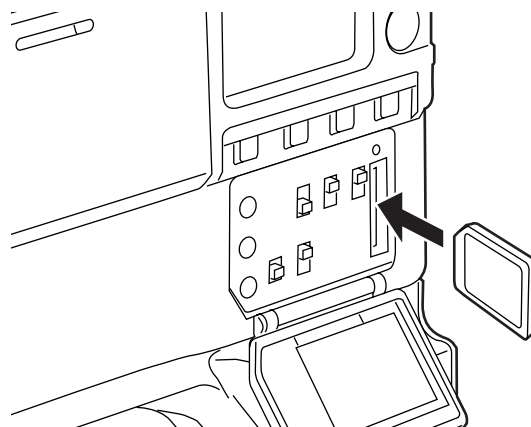

<Note>

Before inserting the setup card, check that it is pointed in the correct direction. If the card meets with resistance and if it is difficult to insert, it may mean that it is the wrong way round or upside down. Do not force the card into the slot but check its direction again and insert it properly.

Removing the setup card

Open the switch cover, check that the BUSY lamp is not lighted, and push the setup card further into the unit. This causes the card to partially pop out from the insertion slot. Take hold of the card, remove it, and close the switch cover.

Bear in mind the following points when using and saving the setup cards.

- Avoid high temperatures and high humidity levels.
- Keep the cards away from water.
- Avoid exposing the cards to electrical charges.

Keep the setup card inside the unit with the cover closed.

Chapter 4 Adjustments and settings for recording

4-9-2 Setup card operations

To format the setup card, save the setting data on the card or read the saved data from the card, first perform a menu operation to open the <CARD READ/WRITE> screen from the FILE page.

```
→< CARD READ/WRITE >
R. SELECT      : 1
  READ
W. SELECT      : 1
  WRITE
CARD CONFIG
TITLE READ

TITLE :
1 : ***** 5 : *****
2 : ***** 6 : *****
3 : ***** 7 : *****
4 : ***** 8 : *****
```

Formatting the setup card

- 1 Perform the menu operations, and display the “CARD READ/WRITE” screen.
- 2 Turn the JOG dial button to move the arrow (cursor) to the CARD CONFIG item.
- 3 When the JOG dial button is pressed, the following message appears on the screen.

```
CONFIG?
YES
→ NO
```

- 4 To proceed with the formatting of the setup card, turn the JOG dial button to move the arrow (cursor) to YES, and press the JOG dial button. When the formatting of the card is completed, the following message appears.

```
CONFIG OK
```

If one of the following messages appears when the JOG dial button is pressed, the card will not be formatted

Error message	Remedial action
CONFIG NG NO CARD (setup card has not been inserted)	Insert the card.
CONFIG NG ERROR (the card cannot be formatted)	The card may be defective. Replace it.
CONFIG NG WRITE PROTECT	Remove the card to cancel write protect.

- 5 Press the MENU button to exit the menu operations. The setting menu is cleared, and the displays showing the unit’s current statuses appear at the top and bottom of the viewfinder screen.

<Note>

Data titles cannot be recognized when the setup card was inserted while the CARD READ/WRITE screen was open. Move the arrow (cursor) to the TITLE READ item, and press the JOG dial button. The data title is recognized, and the title is displayed.

Saving the data settings on the card

- 1 Perform the menu operations, and display the “CARD READ/WRITE” screen.

Selecting the file No.

- 2 Turn the JOG dial button to move the arrow (cursor) to the W.SELECT item and press the JOG dial button.

```
< CARD READ/WRITE >
R. SELECT      : 1
  READ
→ W. SELECT      : 1
  WRITE
CARD CONFIG
TITLE READ

TITLE :
1 : ***** 5 : *****
2 : ***** 6 : *****
3 : ***** 7 : *****
4 : ***** 8 : *****
```

- 3 Turn the JOG dial button to select a number from 1 to 8, and press the JOG dial button.

Chapter 4 Adjustments and settings for recording

Giving a title to the selected file

- 4 Turn the JOG dial button to move the arrow (cursor) to the "TITLE:" item.

```

< CARD READ/WRITE >
R. SELECT      : 1
READ
W. SELECT      : 1
WRITE
CARD CONFIG
TITLE READ
→ TITLE:
1: ***** 5: *****
2: ***** 6: *****
3: ***** 7: *****
4: ***** 8: *****
    
```

- 5 When the JOG dial button is pressed, the arrow (cursor) moves to the title input area, and the input mode is established.

```

< CARD READ/WRITE >
R. SELECT      : 1
READ
W. SELECT      : 1
WRITE
CARD CONFIG
TITLE READ
↓
TITLE:
1: ***** 5: *****
2: ***** 6: *****
3: ***** 7: *****
4: ***** 8: *****
    
```

- 6 Press the JOG dial button again and turn it until the character to be set is displayed. When the button is turned, the character displayed is switched in the following sequence:

- Space: □
- ↓
- letters: A—Z
- ↓
- numbers: 0—9
- ↓
- symbols: ', >, <, /, -

- 7 Press the JOG dial button to enter the character.

- 8 Turn the JOG dial button to move the arrow (cursor) to the next position (right), and repeat steps 6 and 7 to set the characters (maximum of 8).

Saving the data settings to the selected file

- 9 When the title has been input, turn the JOG dial button to move the arrow (cursor) to the ":" position.

```

< CARD READ/WRITE >
R. SELECT      1
READ
W. SELECT      1
WRITE
CARD CONFIG
TITLE READ
↓
TITLE:
1: ***** 5: *****
2: ***** 6: *****
3: ***** 7: *****
4: ***** 8: *****
    
```

- 10 When the JOG dial button is pressed, the arrow (cursor) returns to the TITLE: item.

- 11 Turn the JOG dial button to move the arrow (cursor) to the WRITE item.

- 12 When the JOG dial button is pressed, the following message appears.

```

WRITE?
  YES
→  NO
TITLE:
    
```

If one of the following messages appears when the JOG dial button is pressed, the data cannot be saved.

Error message	Remedial action
WRITE NG NO CARD (setup card has not been inserted)	Insert the card.
WRITE NG FORMAT ERROR (formatting error)	The card was formatted by a device other than the unit. Replace the card.
WRITE NG ERROR (the data cannot be saved)	The card may be defective. Replace it.
WRITE NG WRITE PROTECT	Remove the card to cancel write protect.

Chapter 4 Adjustments and settings for recording

- 13 Turn the JOG dial button to move the arrow (cursor) to YES, and press the JOG dial button.
When the data saving is completed, the following message appears.

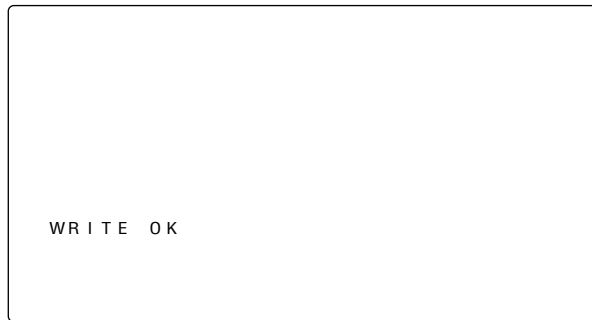

- 14 Press the MENU button to exit the menu operations.
The setting menu is cleared, and the displays showing the unit's current statuses appear at the top and bottom of the viewfinder screen.

Loading the data saved on the card

- 1 Perform the menu operations, and display the "CARD READ/WRITE" screen.
If the data is given a title when it is saved, the title will also be displayed.

Selecting the file No

- 2 Turn the JOG dial button to move the arrow (cursor) to the R.SELECT item and press the JOG dial button.

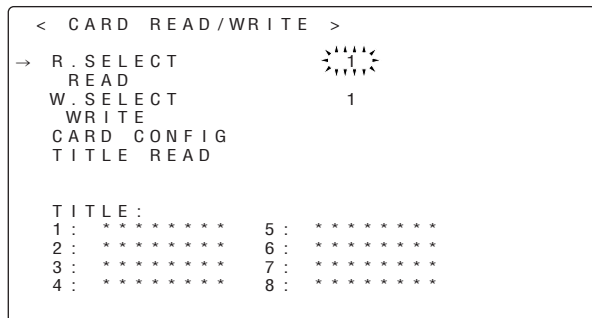

- 3 Turn the JOG dial button to select any number from 1 to 8, and press the JOG dial button.

Loading the data of the selected file

- 4 Turn the JOG dial button to move the arrow (cursor) to the READ item.

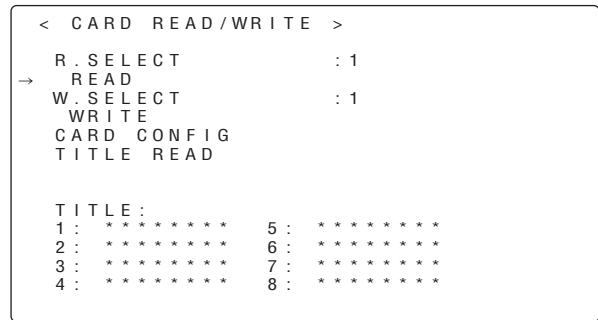

- 5 When the JOG dial button is pressed, the following message appears.



- 6 Turn the JOG dial button to move the arrow (cursor) to YES, and press the JOG dial button.
When the data loading is completed, the following message appears.



Chapter 4 Adjustments and settings for recording

If one of the following messages appears when the JOG dial button is pressed, the data cannot be loaded.

Error message	Remedial action
READ NG NO CARD (setup card has not been inserted)	Insert the card.
READ NG FORMAT ERROR (formatting error)	The card was formatted by a device other than the unit. Replace the card.
READ NG NO FILE (file not found)	Save the file data.
READ NG ERROR (the data cannot be loaded)	Data saved by devices other than unit cannot be loaded.

- Press the MENU button to exit the menu operations. The setting menu is cleared, and the displays showing the unit's current statuses appear at the top and bottom of the viewfinder screen.

4-9-3 How to use the user data

The setting data can be written in the user area of the unit's internal memory and data written in the memory can be read from this area.

Use of this data speeds up the process of reproducing suitable setup statuses.

To write the data, first perform a menu operation to open the <INITIALIZE> screen from the FILE page, and to read the user data that has been written, first perform a menu operation to open the <SCENE> screen from the FILE page.

```

->< INITIALIZE >
  READ FACTORY DATA
  WRITE USER DATA
  RESET LENS FILES
    
```

```

->< SCENE >
  READ USER DATA
  SCENE SEL          : 1
  READ
  WRITE
  RESET

  TITLE1 : *****
  TITLE2 : *****
  TITLE3 : *****
  TITLE4 : *****
    
```

Writing the setting data in the user area

- Perform a menu operation to open the <INITIALIZE> screen.
- Turn the JOG dial button to move the arrow (cursor) to the WRITE USER DATA item.

```

< INITIALIZE >
  READ FACTORY DATA
-> WRITE USER DATA
  RESET LENS FILES
    
```

- When the JOG dial button is pressed, the following message appears.

```

  WRITE?
  YES
-> NO
  YES
    
```

- Turn the JOG dial button to move the arrow (cursor) to YES, and press the JOG dial button. The setting data is now written in the user area of the unit's internal memory.
- Press the MENU button to exit the menu operations.

Loading the user data

- Perform a menu operation to open the <SCENE> screen.
- Turn the JOG dial button to move the arrow (cursor) to the READ USER DATA item.

Chapter 4 Adjustments and settings for recording

- 3 When the JOG dial button is pressed, the following message appears.



- 4 Turn the JOG dial button to move the arrow (cursor) to YES, and press the JOG dial button.
The data written in the user area of the unit's internal memory is now read, and the setting is completed.

- 5 Press the MENU button to exit the menu operations.

4-9-4 How to use the scene file data

The setting data can be written in the scene file area of the unit's internal memory and the data written can be read from this area. Up to four scene files can be registered. By using this data, the appropriate setup statuses can be established speedily.

At the factory, the unit's default statuses were set in TITLE1-4.

Writing the setting data used for the scene files

- 1 Perform a menu operation to open the <SCENE> screen.
- 2 Turn the JOG dial button to move the arrow (cursor) to the SCENE SEL item.
- 3 When the JOG dial button is pressed, the scene file number starts flashing. Turn the JOG dial button to select the scene file in which data is to be saved.

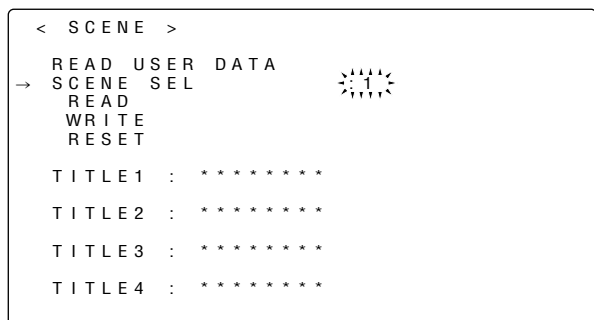

- 4 Press the JOG dial button to enter the scene file.

- 5 Turn the JOG dial button to move the arrow (cursor) to the WRITE item.

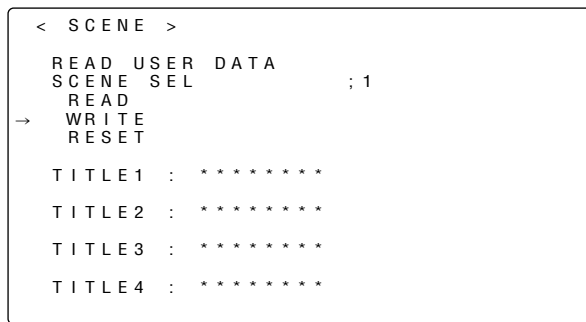

- 6 When the JOG dial button is pressed, the following message appears.

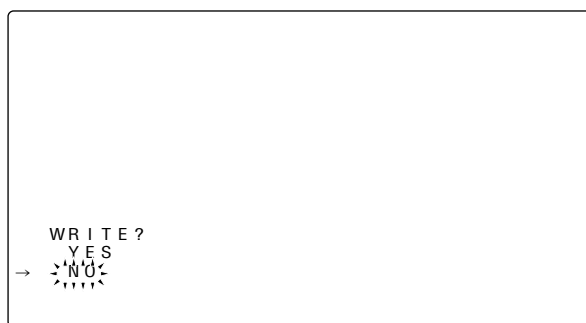

- 7 Turn the JOG dial button to move the arrow (cursor) to YES, and press the JOG dial button.
The setting data is now stored in the scene file area of the unit's internal memory.

- 8 Press the MENU button to exit the menu operations.

Reading the setting data used for the scene files

- 1 Perform a menu operation to open the <SCENE> screen.
- 2 Turn the JOG dial button to move the arrow (cursor) to the SCENE SEL item.
- 3 When the JOG dial button is pressed, the scene file number starts flashing. Turn the JOG dial button to select the scene file whose data is to be loaded.

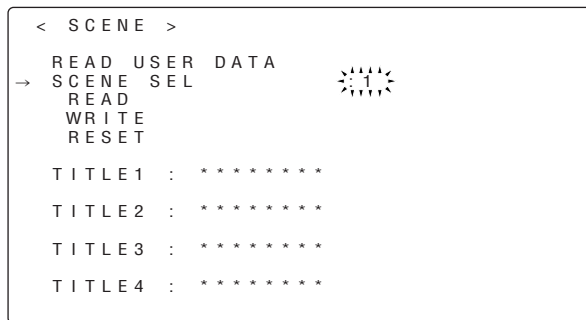

Chapter 4 Adjustments and settings for recording

4 Press the JOG dial button to enter the scene file.

5 Turn the JOG dial button to move the arrow (cursor) to the READ item.

```
< SCENE >
READ USER DATA
SCENE SEL          : 1
→ READ
WRITE
RESET

TITLE1 : *****
TITLE2 : *****
TITLE3 : *****
TITLE4 : *****
```

6 When the JOG dial button is pressed, the following message appears.

```
READ?
→ YES
  NO
```

7 Turn the JOG dial button to move the arrow (cursor) to YES, and press the JOG dial button. The data stored in the scene file area of the unit's internal memory is read, and the setting is completed.

8 Press the MENU button to exit the menu operations.

Returning the setting data used for the scene files to the factory settings

1 Perform a menu operation to open the <SCENE> screen.

2 Turn the JOG dial button to move the arrow (cursor) to the SCENE SEL item.

3 When the JOG dial button is pressed, the scene file number starts flashing. Turn the JOG dial button to select the scene file whose data is to be reset.

```
< SCENE >
READ USER DATA
→ SCENE SEL          : 1
READ
WRITE
RESET

TITLE1 : *****
TITLE2 : *****
TITLE3 : *****
TITLE4 : *****
```

4 Press the JOG dial button to enter the scene file.

5 Turn the JOG dial button to move the arrow (cursor) to the RESET item.

```
< SCENE >
READ USER DATA
SCENE SEL          : 1
READ
WRITE
→ RESET

TITLE1 : *****
TITLE2 : *****
TITLE3 : *****
TITLE4 : *****
```

6 When the JOG dial button is pressed, the following message appears.

```
RESET?
→ YES
  NO
```

7 Turn the JOG dial button to move the arrow (cursor) to YES, and press the JOG dial button. The data stored in the scene file area of the unit's internal memory is reset and the factory settings are restored.

8 Press the MENU button to exit the menu operations.

Chapter 4 Adjustments and settings for recording

Appending titles to the setting data used for the scene files

- 1 Perform a menu operation to open the <SCENE> screen.
- 2 Turn the JOG dial button to move the arrow (cursor) to the scene file TITLE1, 2, 3 or 4 item where the title is to be appended.

```
< SCENE >
READ USER DATA
SCENE SEL          : 1
READ
WRITE
RESET
-> TITLE1 : *****
TITLE2 : *****
TITLE3 : *****
TITLE4 : *****
```

- 3 When the JOG dial button is pressed, the arrow (cursor) moves to the title input area, and the input mode is established.

```
< SCENE >
READ USER DATA
SCENE SEL          : 1
READ
WRITE
RESET
TITLE1 : * *****
TITLE2 : *****
TITLE3 : *****
TITLE4 : *****
```

- 4 Press the JOG dial button again and turn it until the character to be set is displayed. When the button is turned, the character displayed is switched in the following sequence:

Space: □
↓
letters: A—Z
↓
numbers: 0—9
↓
symbols: ', >, <, /, -

- 5 Press the JOG dial button to enter the character.
- 6 Turn the JOG dial button to move the arrow (cursor) to the next position (right), and repeat steps 4 and 5 to set the characters (maximum of 8).
- 7 When the title has been input, turn the JOG dial button to move the arrow (cursor) to the “:” position.

- 8 When the JOG dial button is pressed, the arrow (cursor) returns to the TITLE1, 2, 3 or 4 item.
- 9 Turn the JOG dial button to move the arrow (cursor) to the WRITE item.
- 10 When the JOG dial button is pressed, the following message appears.

```
WRITE?
YES
-> NO
TITLE :
```

- 11 Turn the JOG dial button to move the arrow (cursor) to YES, and press the JOG dial button. The title is stored in the scene file area of the unit's internal memory.

- 12 Press the MENU button to exit the menu operations.

Chapter 4 Adjustments and settings for recording

4-9-5 How to return the menu settings to the user standard settings

The setting statuses of the unit's menus can be returned to the user standard settings registered in 4-9-3. There are two ways to do this: one method is to read (load) the USER DATA as described in "4-9-3 How to use the user data" and the other enables the return without performing any menu operations.

Operation method without performing FILE menu operations

- 1 Set the POWER switch to the OFF position.
- 2 Set the WHITE BAL switch to the PRST position.

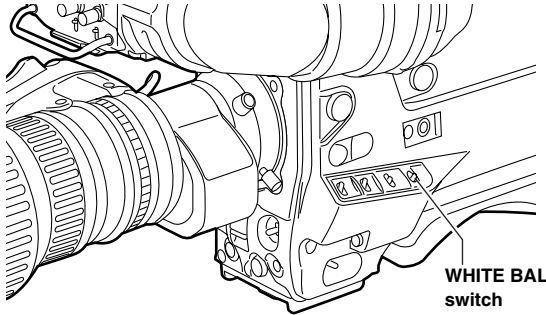

- 3 Set the POWER switch to the ON position while holding down the AUTO W/B BAL switch. The USER menu item settings are all returned together to the standard user data.

4-9-6 How to return the menu settings to the factory standard settings

The unit's menu setting statuses can be returned to the factory standard settings. To do this, first perform a menu operation to open the <INITIALIZE> screen from the FILE page.

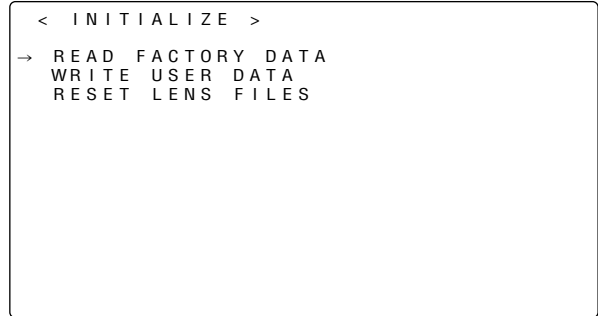

How to return the menu settings (except for the lens file data) to the factory standard settings

- ① Select the READ FACTORY DATA menu item on the <INITIALIZE> screen, and press the jog dial button.
- ② Turn the jog dial button, and move the arrow (cursor) to YES on the READ? screen.
- ③ Press the jog dial button. The menu settings are now returned to the factory standard settings.

How to return the lens file data to the factory standard settings

- ① Select the RESET LENS FILES menu item on the <INITIALIZE> screen, and press the jog dial button.
- ② Turn the jog dial button, and move the arrow (cursor) to YES on the RESET ALL LENS DATA? screen.
- ③ Press the jog dial button. The lens file data is returned to the factory standard settings.

4-9-7 How to use the lens file data

This unit comes with a white shading compensation function for the lens. This function enables up to six white shading compensation settings of the lens to be stored as the lens file data. Using this lens file data, the appropriate white shading adjustment can be accomplished speedily even after the lens is changed.

For details on data storing, reading and other operations, refer to "5-3 Attaching the lens and performing the flange back and white shading adjustments."

Chapter 5 Preparation

5-1 Supplying the power

A battery pack or an AC power source can be used as this unit's power supply.

To use the battery pack, there is the following choice of makes of batteries:

- Panasonic
- Anton-Bauer
- IDX
- PACO
- Sony

<Notes>

- Batteries of other makes can also be supported by changing the setting menu but no guarantees are made for the system when they are actually used with this unit.
- Before using the battery pack, recharge the battery using the battery charger.
(For details on the recharging method, refer to the operating instructions of the battery concerned.)

```
→< BATTERY / TAPE >
BATTERY SELECT : PRO14
EXT DC IN SELECT : AC-ADPT
BATT NEAR END ALARM : OFF
BATT NEAR END CANCEL : ON
BATT END ALARM : ON
BATT REMAIN FULL : 70%

TAPE NEAR END ALARM : ON
TAPE NEAR END TIME : 2min
TAPE END ALARM : ON
TAPE REMAIN / ■ : 3min / ■
```

5-1-1 Attaching the battery and setting the battery type

Using the Anton Bauer battery pack

1 Attach the battery pack made by Anton Bauer.

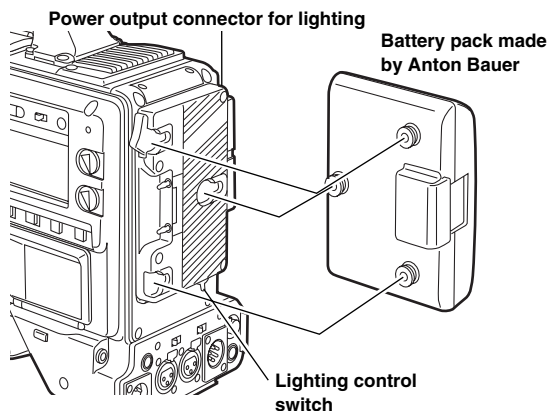

<Reference>

A battery holder made by Anton Bauer is equipped with a power output connector for the lighting and a lighting control switch to enable a light to be easily attached. For details on the lighting systems available, contact Anton Bauer.

2 Insert the battery pack and slide it in the direction of the arrow.

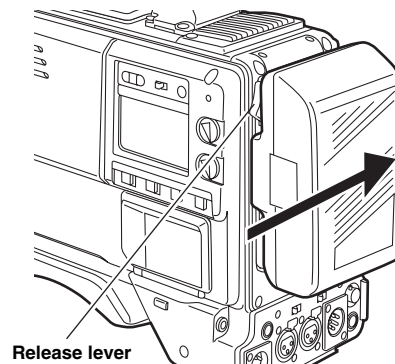

<Reference>

To remove the battery pack, slide it in the opposite direction to the one in which it was attached while keeping the release lever on the battery holder pulled down all the way.

3 Set the battery type.

Select the battery type using the BATTERY SELECT menu item. This item is selected from the <BATTERY/TAPE> screen on the VTR FUNCTION page. For details, refer to "7-8-3 BATTERY SETTING1."

Anton Bauer batteries which can be used

- DIONIC90
- DIONIC160
- HYTRON50
- HYTRON100
- HYTRON120
- PRO14
- TRIM14

<Note>

Use the DIONIC80 at the DIONIC90 setting.

Chapter 5 Preparation

Using the BP-90 type battery pack

1 Remove the battery holder.

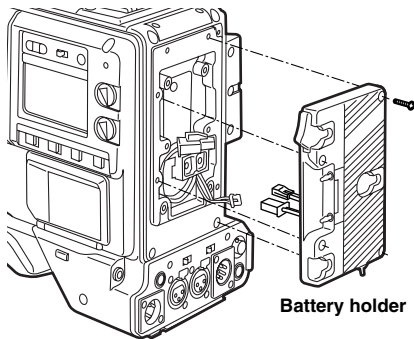

2 Attach the battery case to the unit.

- ① Connect the unit's cable with the cable of the BP-90 type battery case.
- ② Use a screwdriver to attach the BP-90 type battery case to the unit.

The holes for tightening the screws can be seen when the cover is opened and the rubber caps are raised. Use a screwdriver to tighten the screws, and attach the battery case to the unit. Ensure that the screws are tightened up as far as they will go.

<Note>

- Do not pull the rubber caps with great force.
- Be careful not to catch up the cables when attaching the battery case.

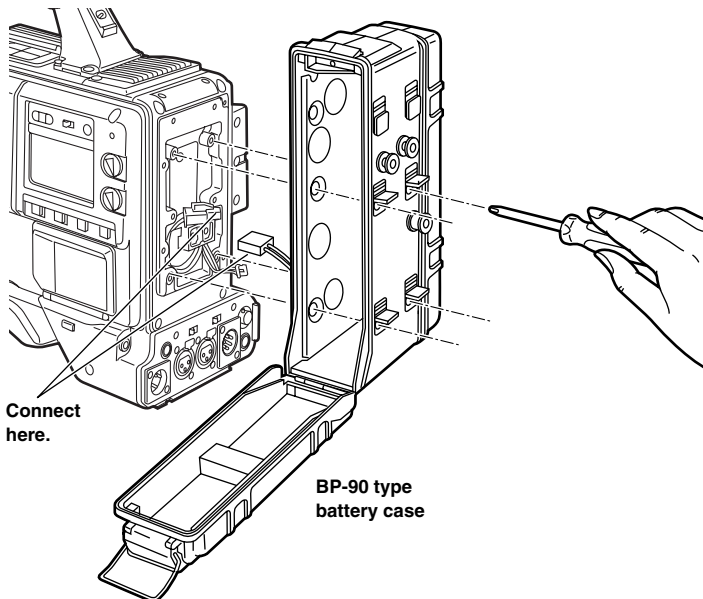

3 Connect the plug of the battery pack to the connector inside the battery case, and insert the battery pack into the case.

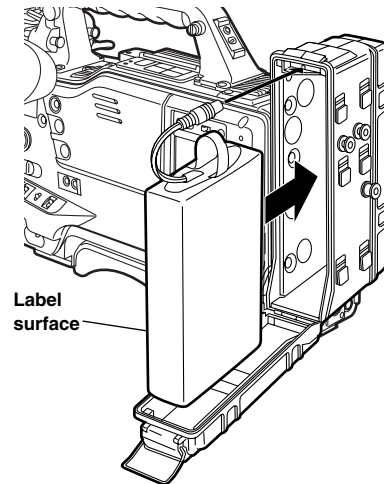

<Note>

Ensure that the power is turned off before connecting or disconnecting the plugs.

4 Set the battery type. Select the battery type using the BATTERY SELECT menu item. This item is selected from the <BATTERY/TAPE> screen on the VTR FUNCTION page. For details, refer to "7-8-3 BATTERY SETTING1."

Chapter 5 Preparation

Using the NP-1 type battery pack

- 1 Remove the battery holder.
- 2 Attach the NP-1 type battery case to the unit.
 - ① Tighten the mounting screws.
 - ② Tighten the power contact screws.
 - ③ Insert the top of the detached cover in the direction shown by the arrows.
 - ④ Align the holes in the bottom of the cover (metal part) with the holes at the bottom of the case, and use the screws to attach the case.

<Note>

When mounting the battery holder, take care not to pinch the connecting cord.

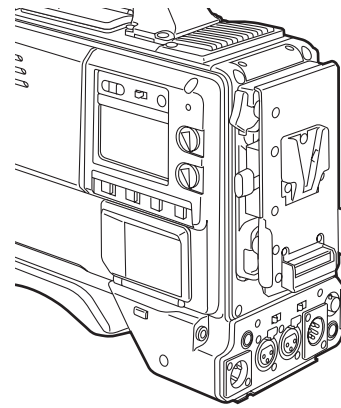
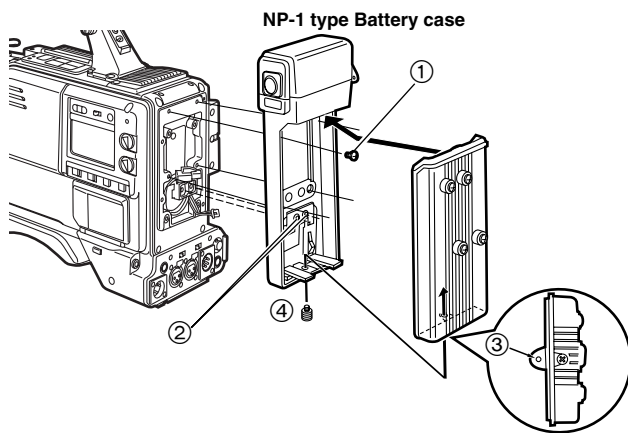

- 3 Set the battery type.

Select the battery type using the BATTERY SELECT menu item. This item is selected from the <BATTERY/TAPE> screen on the VTR FUNCTION page. When using a nickel-cadmium battery which cannot be selected using the BATTERY SELECT item setting, select NiCd14(14V), NiCd13(13 V) or NiCd12(12 V), whichever setting corresponds to the battery's voltage, and set the items that correspond to the characteristics of the battery.

If the battery is not a nickel-cadmium battery, select TYPE A or TYPE B, and set the items that correspond to the characteristics of the battery.

For details, refer to "7-8-4 BATTERY SETTING2."

<Note>

Address all inquiries concerning the V-mount adapter plate to your dealer.

Using the V-mount type battery pack

Attach the V-mount adapter plate.
Insert it in the direction shown by the arrows, and slide it into place.

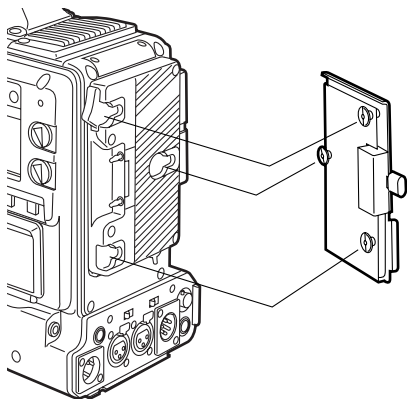

Chapter 5 Preparation

5-1-2 Using an AC power supply

When the AJ-B75 AC adapter made by Panasonic is used

- 1 Connect the DC OUT connector on the AJ-B75 AC adapter to the DC IN socket on the unit.

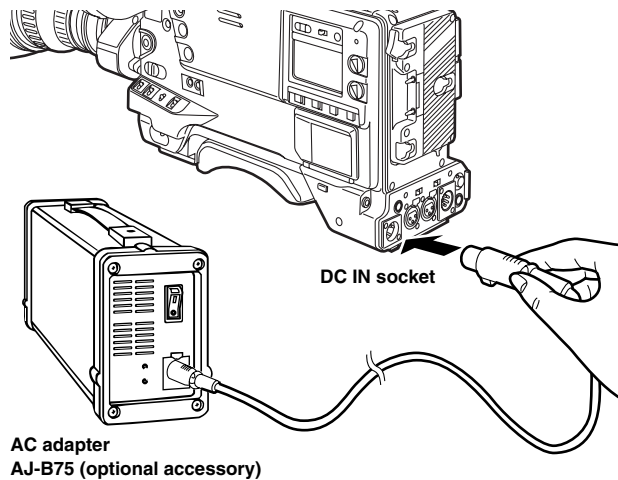

- 2 Set the power of the AC adapter to ON.
- 3 Set the unit's power switch to ON.

When using an external power supply other than the AJ-B75 AC adapter, check the pin signals of its external DC input connector and use the polarities correctly. Supplying +12V power to the GND terminal by mistake may give rise to ignition, resulting in a fire, or it may cause injury.

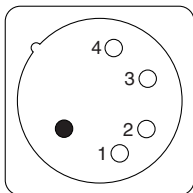

External DC input socket

Pin no.	Signal
1	GND
2, 3	-
4	+12V

<Notes>

- Power from the AC adapter takes precedence when both a battery pack and AC adapter have been connected. It is also possible to attach/remove a battery while the AC adapter is being used.
- When using the AC adapter, be absolutely sure to first set the power of the AC adapter to ON and then set the unit's power switch to ON. If the power is turned on in the reverse sequence, the output voltage of the AC adapter will rise gradually, and the unit may malfunction as a result.

5-2 Attaching the viewfinder and adjusting its position

Refer to the instructions accompanying the viewfinder. A slide rail is required for attaching a viewfinder (AJ-VF15 or AJ-VF20W) other than the AJ-VF15B or AJ-VF20WB.

- If you wish to install the slide rail, ask your dealer to obtain it as an accessory part.
 - Slide rail (VFC3995) 1
 - Attachment screw (XSB3+8VZ) . . . 2

How to install the slide rails

- 1 Remove the two screws on the top of the AJ-VF15 or AJ-VF20W, and remove the mounting unit. Leave the screws attached to the mounting unit.

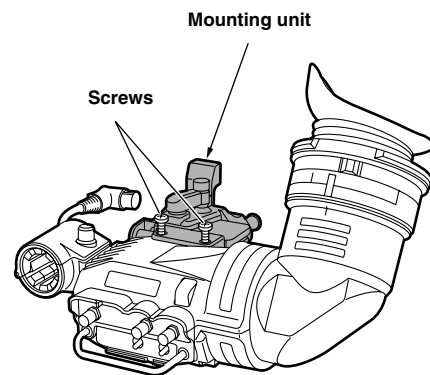

- 2 Install the slide rail by screwing it into place using the two screws that come with the rail.

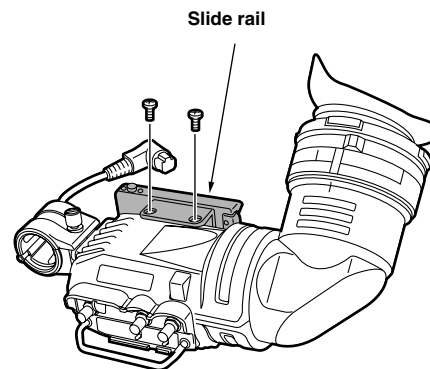

Chapter 5 Preparation

5-3 Attaching the lens and performing the flange back and white shading adjustments

Attaching the lens

- 1 Raise the lever for securing the lens, and detach the mount cap.

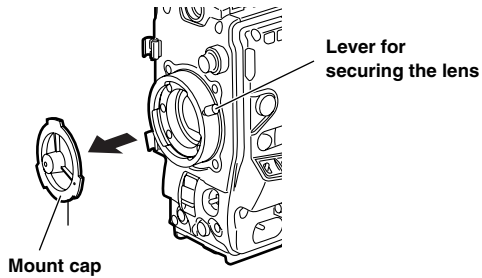

- 2 Align the center mark of the lens with the groove in the top center of the lens mount, and attach the lens.

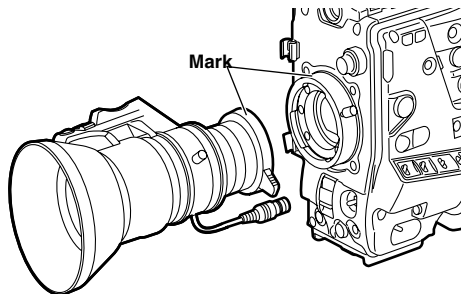

- 3 Push down the lever for securing the lens to secure the lens.

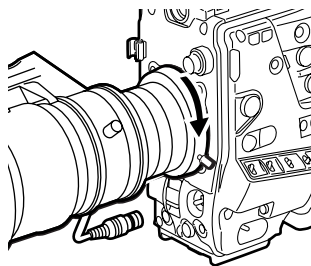

- 4 Push the cable into the cable clamp, and connect it to the LENS socket.

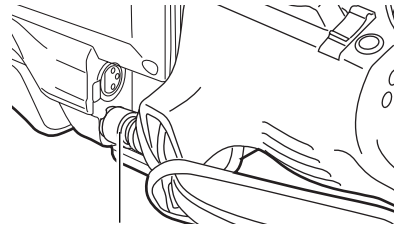

LENS socket

- 5 Proceed with the flange back adjustment for the lens.

<Notes>

- For details on how to handle the lens, refer to the operating instructions of the lens.
- While the lens is removed, attach the mount cap to protect the unit.

Chapter 5 Preparation

Adjusting the lens flange

If the subject is not focused properly in the telephoto and wide-angle modes during zoom operations, adjust the flange back (distance from the lens mounting surface to the image-forming surface).

Once this adjustment is done, it need not be redone unless the lens is replaced.

<Note>

For details on the adjustment method and lens positions, refer also to the operating instructions that accompany the lens.

- 1 Attach the lens to the camera.
At this stage, do not forget to connect the lens cable.
- 2 Set the lens aperture to manual and open the aperture.

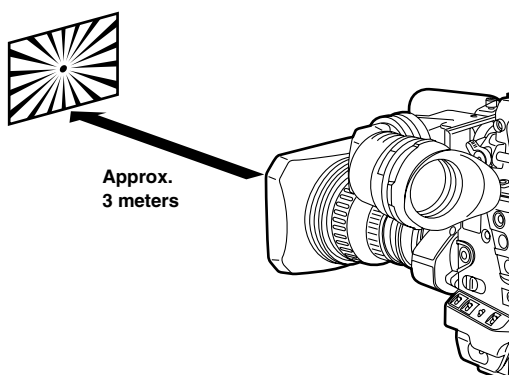

- 3 Set the lighting in such a way that the appropriate video output level is achieved at a distance of about 3 meters away from the chart used for the flange back adjustment. If the video level is too high, use the filters and shutter.

- 4 Loosen the screw securing the F.f (flange focus) ring.

<Note>

On some lenses, this may be marked as F.b (flange back) ring.

- 5 Set the zoom ring to the telephoto position either manually or electrically.

- 6 Shoot the chart used for the flange back adjustment, and turn the distance ring to adjust the focus.

- 7 Set the zoom ring to the wide-angle position, and turn the F.f ring to adjust the focus.
Take care not to move the distance ring during this process.

- 8 Repeat steps 5 to 7 until the focus is adjusted at both the telephoto and wide-angle positions.

- 9 Tighten the screw securing the F.f ring.

Adjusting the white shading of the lens

The white shading is adjusted as follows.

<Notes>

- Coloring may occur in the vertical direction near where the lens aperture is open even when the white shading has been adjusted. This is something that is inherent to lenses and optical systems and is therefore not indicative of a failure or malfunctioning.
- The white shading cannot be adjusted when the digital zoom function is working. To adjust the white shading, release the digital zoom function first (by pressing again the USER button to which D.ZOOM is allocated).

- 1 Attach the lens to the camera.
At this stage, do not forget to connect the lens cable.
- 2 Set the electronic shutter to OFF and the gain to "L (0 dB)."
- 3 If the extender is attached to the lens, release the extender function.
- 4 Perform a menu operation to open the <VF DISPLAY> screen from the VF page, check that the settings selected for the ZEBRA1 DETECT item, ZEBRA2 DETECT item and ZEBRA2 item match the settings shown in the figure below. If they differ, make the appropriate changes, and then close the menu screen.

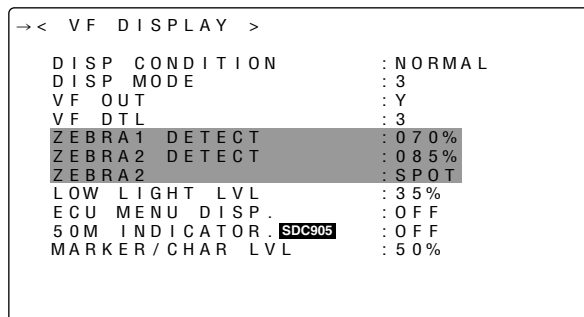

- 5 Set the ZEBRA switch on the viewfinder to ON.
- 6 Shoot a white sheet of paper with no unevenness of color.

<Note>

Since fluorescent lights, mercury lamps and other such kinds of lighting tend to flicker, use a light source which is free from flicker such as sunlight or a halogen lamp.

Chapter 5 Preparation

7 Set the lens aperture control to manual, and adjust it so that the zebra pattern covers the whole screen. Check that the lens aperture is between F4 and F11.

<Notes>

- The zebra pattern will not cover the whole screen if there is any unevenness in the lighting. In this case, make adjustments to the position of the lighting, etc.
- Make adjustments to the position of the lighting, etc. also when the lens aperture is not between F4 and F11.
- Be absolutely sure to leave the electronic shutter at OFF.

8 ① Set the WHITE BAL selector switch to “A” or “B,” and use the AUTO W/B BAL switch to adjust the white balance automatically (AWB).

② Use the AUTO W/B BAL switch to adjust the black balance automatically (ABB).

③ Again, use the AUTO W/B BAL switch to adjust the white balance automatically (AWB).

9 Repeat step 7.

10 Perform a menu operation to open the <WHITE SHADING> screen from the MAINTENANCE page.

11 Turn the JOG dial button to move the arrow (cursor) to the DETECTION (V.SAW) item, and press the JOG dial button to execute white shading compensation.

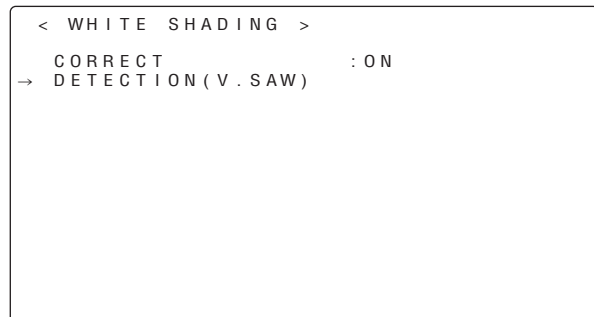

12 When the JOG dial button is pressed, the following message appears.

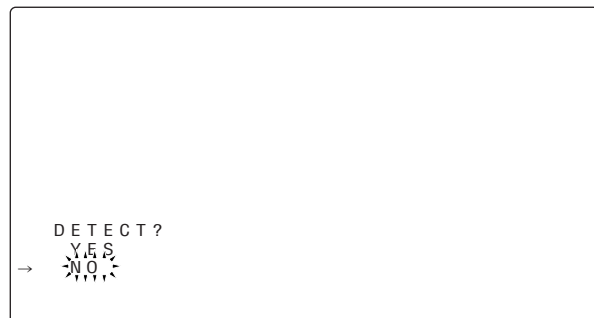

13 Turn the JOG dial button to move the arrow (cursor) to YES, and press the JOG dial button.

ACTIVE now appears on the screen. This indicates that the white shading is now being automatically compensated. Upon completion of the adjustments, W-SHD OK is displayed.

<Note>

Depending on the KNEE settings, “LEVEL OVER” may appear on the screen and white shading compensation may not be possible. If this is the case, either stop down the lens or set the AUTO KNEE OUTPUT switch to OFF, then perform a menu operation to open the <KNEE/LEVEL> screen from the PAINT screen, select “OFF” as the MANUAL KNEE item setting, and repeat steps 4 through 9. After “W-SHD OK” has appeared on the display, select “ON” again as the MANUAL KNEE item setting.

14 If the extender is attached to the lens, turn on the extender function or, alternatively, if the ratio converter is attached, turn on the ratio converter function. In either case, repeat steps 7 through 13.

The compensation values for 3 patterns—namely, when the lens extender is used, when the ratio converter is used and when neither the lens extender nor ratio converter is used—are stored in the unit as the data of one lens file.

This now completes the white shading adjustments. The adjustment values are now stored in the non-volatile memory so that even when the unit’s power is turned off, there will be no further need to perform the white shading adjustment.

Chapter 5 Preparation

Storing the lens file data

The white shading adjustment values can be stored in the unit as lens file data.

Selecting the file No.

- 1 Perform a menu operation to open the <LENS FILE> screen from the FILE page, and turn the JOG dial button to move the arrow (cursor) to the FILE NO. item.
- 2 When the JOG dial button is pressed, the file number starts flashing. Turn the JOG dial button and select the lens file (1 to 8) in which the data is to be stored.

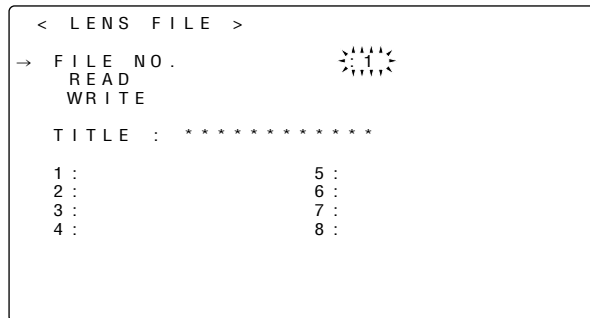

- 3 Press the JOG dial button to enter the lens file.

Giving a title to the selected file NO.

- 4 Turn the JOG dial button to move the arrow (cursor) to the "TITLE:" item.

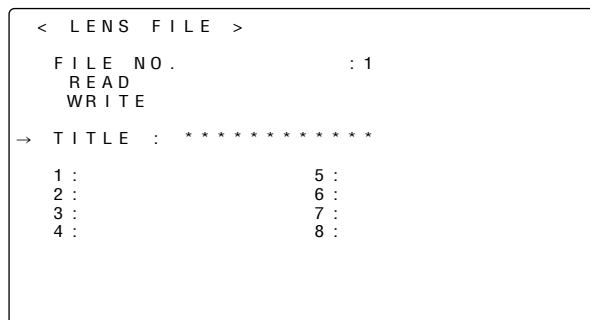

- 5 When the JOG dial button is pressed, the arrow (cursor) moves to the title input area, and the input mode is established.

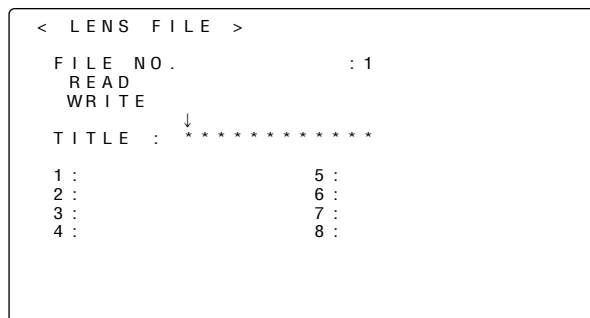

- 6 Press the JOG dial button again and turn it until the character to be set is displayed. When the button is turned, the character displayed is switched in the following sequence:

Space: □
↓
letters: A—Z
↓
numbers: 0—9
↓
symbols: ', >, <, /, -, •, ×

- 7 Press the JOG dial button to enter the character.
- 8 Turn the JOG dial button to move the arrow (cursor) to the next position (right), and repeat steps 6 and 7 to set the characters. (No more than 12 characters may be entered.)
- 9 When the characters have been input, turn the JOG dial button to move the arrow (cursor) to the ":" position.
- 10 When the JOG dial button is pressed, the arrow (cursor) returns to the "TITLE:" item.

- 11 Turn the JOG dial button to move the arrow (cursor) to the "WRITE" item.

- 12 When the JOG dial button is pressed, the following message appears.

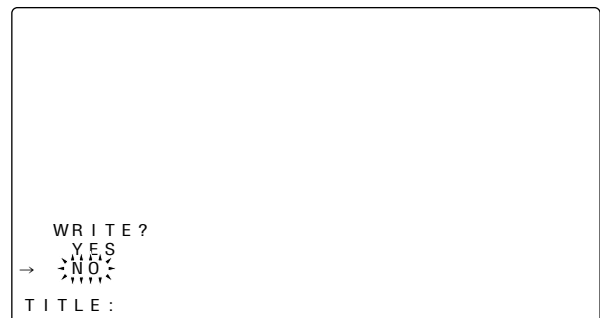

- 13 Turn the JOG dial button to move the arrow (cursor) to YES, and press the JOG dial button. When writing is complete, "WRITE OK" is displayed, indicating that the setting data and title have been stored in the lens file area of internal memory.

- 14 Press the MENU button to exit the menu operations.

Chapter 5 Preparation

Reading the lens file data

- 1 Refer to steps 1 to 3 in “Storing the lens file data,” and enter the lens file.
- 2 Turn the JOG dial button to move the arrow (cursor) to the “READ” item.
- 3 When the JOG dial button is pressed, the following message appears.



- 4 Turn the JOG dial button to move the arrow (cursor) to YES, and press the JOG dial button.
When reading is complete, “READ OK” is displayed, indicating that the lens file data has been read from memory.
- 5 Press the MENU button to exit the menu operations.

How to return the lens file data to the factory standard settings

All the lens file data can be returned to the factory standard settings.

For details, refer to “4-9-6 How to return the menu settings to the factory standard settings.”

Chapter 5 Preparation

5-4 Audio input signal preparations

Prepare to connect the audio components which will supply the audio signals to the unit.

5-4-1 When using the front microphone

The microphone of the AJ-MC700P mic kit (optional accessory) can be attached to the viewfinder.

- 1 Open the mic holder.

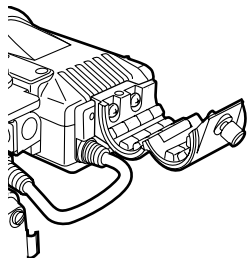

- 2 Attach the microphone, and tighten the locking screw.

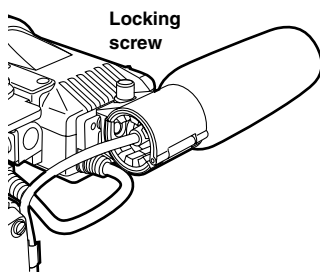

- 3 Connect the microphone's connecting cable to the MIC IN jack on the camera.

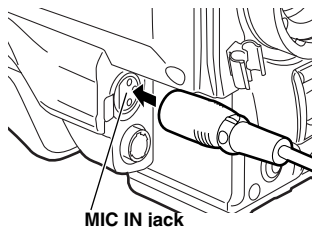

- 4 Set the AUDIO IN switch or switches to "FRONT" in accordance with the audio channel or channels whose sound is to be recorded.

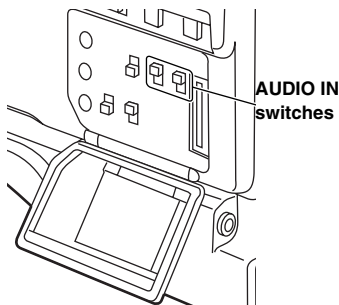

5-4-2 When using an external microphone

First attach the AJ-MH700P mic holder (optional accessory).

- 1 Remove the screws used to attach the mic holder.

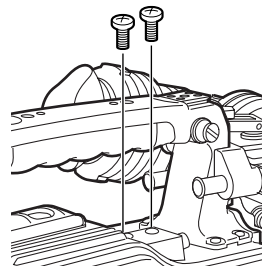

- 2 Attach the mic holder to the main unit using the screws provided with the AJ-MH700P mic holder.

Screws provided with mic holder

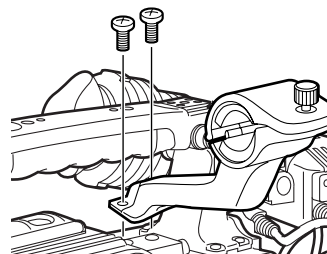

- 3 Attach the microphone to the mic holder, and tighten the locking screw.

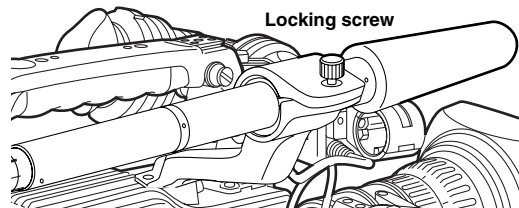

- 4 Connect the microphone's connecting cable to the MIC IN jack on the camera.

- 5 Set the AUDIO IN switch or switches to "FRONT" in accordance with the audio channel or channels whose sound is to be recorded.

Chapter 5 Preparation

5-4-3 When using a wireless receiver

When using an externally connected wireless receiver

Attach the wireless receiver when a wireless system is to be used.

- 1 Attach the wireless receiver to the camera attachment.
- 2 Align the grooves in the camera attachment with the pins on the battery case, etc. to attach the wireless receiver.

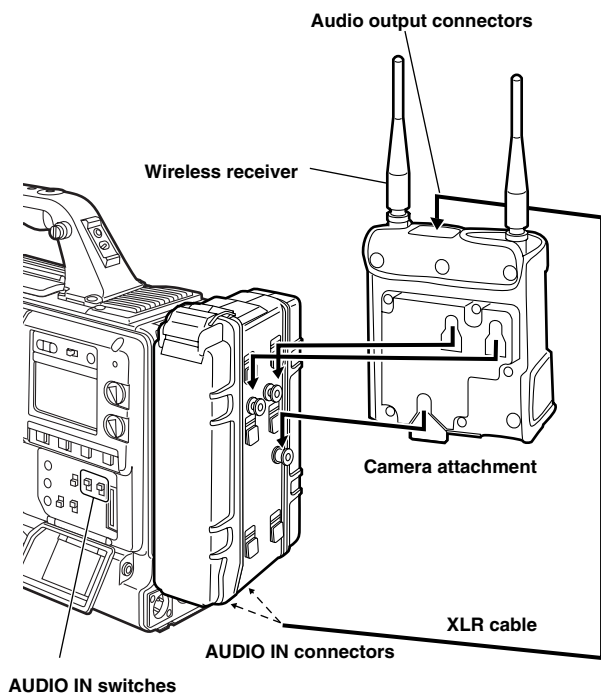

AUDIO IN switches

- 3 Connect the AUDIO IN connectors on the camera with the wireless receiver using the XLR cable.
- 4 Set the AUDIO IN switch or switches for the channel or channels to which the XLR cable has been connected to "REAR."
- 5 Set the LINE/MIC/+48V selector switch on the rear panel to "MIC."

When detaching the wireless receiver, push up the lever on the bottom panel of the camera attachment to disengage it.

<Note>

For details on the operations and other aspects of the wireless receiver, refer to the operating instructions which accompany the receiver.

When using a UniSlot® wireless receiver

- 1 Remove the slot cover, insert the wireless receiver, and screw it down.

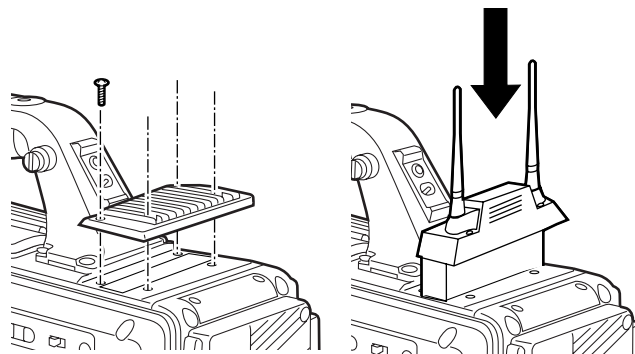

- 2 Set the AUDIO IN switches to WIRELESS for the audio channels whose audio signals are to be recorded.

5-4-4 When using an audio component

- 1 Connect the AUDIO IN connectors on the camera with the audio component using the XLR cable.
- 2 Set the AUDIO IN switch or switches for the channel or channels to which the audio component has been connected to "REAR."
- 3 Set the LINE/MIC/+48V selector switch on the rear panel to "LINE."

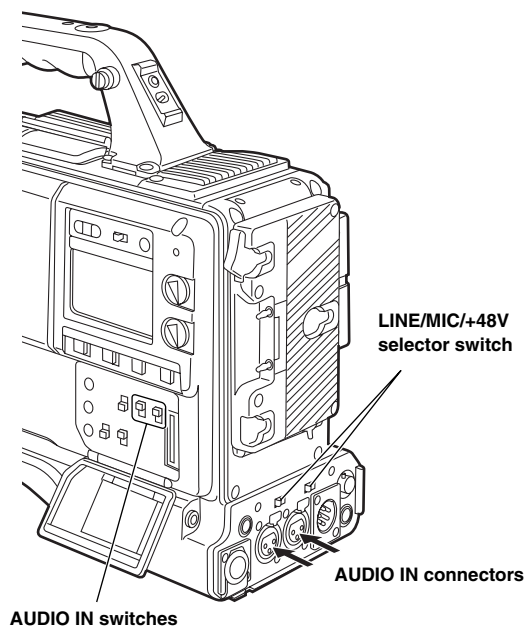

Chapter 5 Preparation

5-5 Mounting the unit on a tripod

Use the tripod attachment to mount the unit on a tripod.

1 Mount the tripod attachment on the tripod.

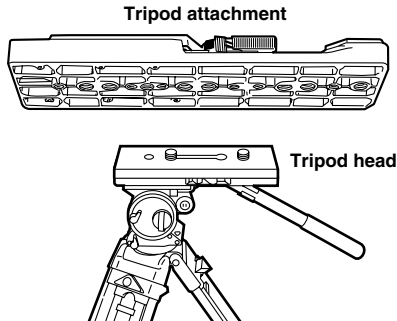

<Note>

Take account of the center of gravity of the unit and that of the tripod attachment when selecting the attachment hole. Check that the diameter of the hole selected matches the diameter of the tripod head screw.

2 Mount the unit on the tripod attachment.

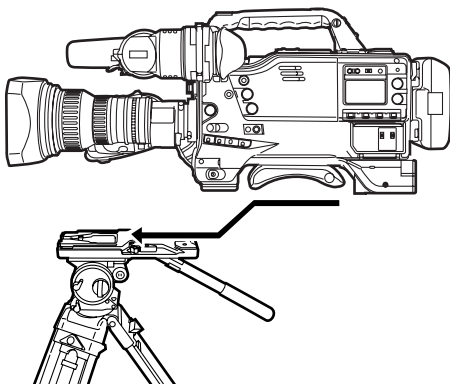

Slide the unit along the groove toward the front until it clicks into place.

Detaching the unit from the tripod attachment

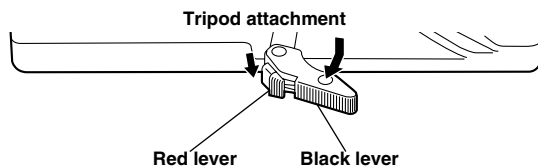

While pushing down the red lever, move the black lever in the direction of the arrow and slide the unit toward the back to remove it.

<Note>

If the pin of the tripod attachment fails to return to its original position after the unit has been detached, again move the black lever in the direction of the arrow while pushing down the red lever, and return the pin to its original position. Bear in mind that the unit cannot be attached if the pin remains in the center.

5-6 Attaching the shoulder belt

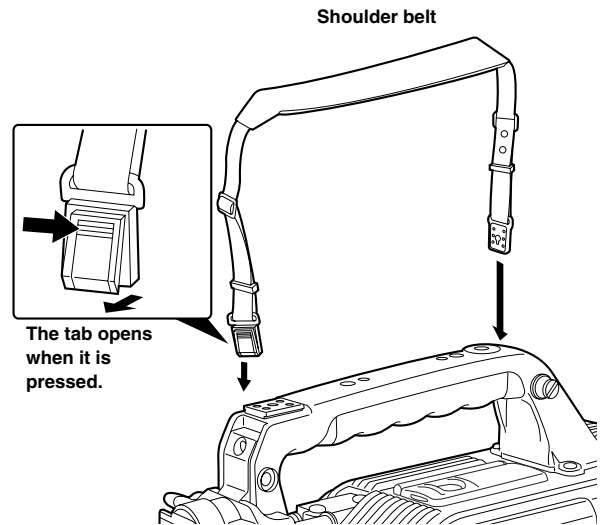

To disengage the shoulder belt, press the tabs.

<Note>

Check that the shoulder belt is attached securely.

5-7 Adjusting the position of the shoulder pad

The shoulder pad can be moved while the slide lever is held down. Its position can be adjusted in 3 mm steps (up to max. of 10 steps or 30 mm) in either the front or back direction.

While holding down the slide lever, move the shoulder pad toward the front or back to the optimum shooting position.

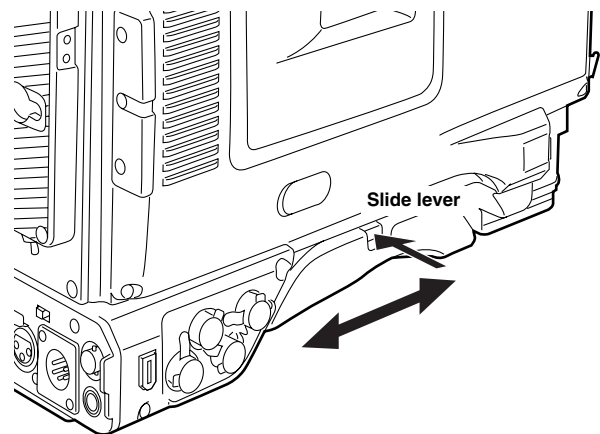

Chapter 5 Preparation

5-8 Attaching the rain cover

Example showing use of the SHAN-RC700 rain cover

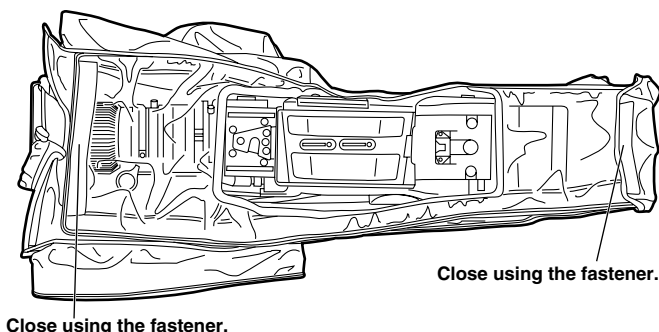
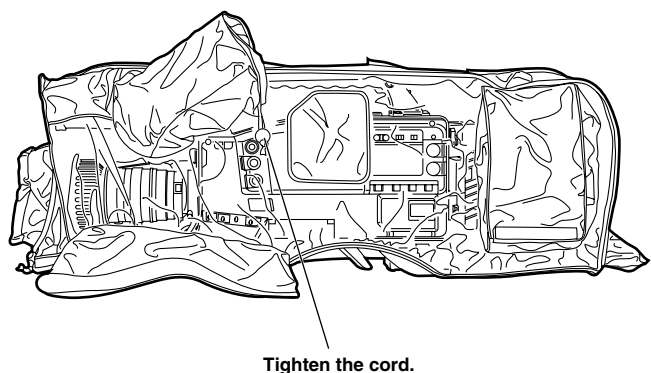

5-9 Connecting the extension control unit (AJ-EC3E)

By connecting the AJ-EC3E extension control unit (optional accessory), some of the functions can be operated by remote control.

When the AJ-EC3E is connected and the POWER switches on the unit and AJ-EC3E are set to ON, the unit is automatically set to the remote control mode.

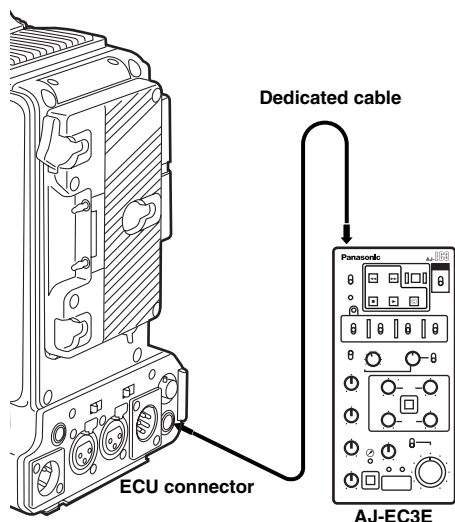

<Notes>

- Before connecting or disconnecting the dedicated cable, be absolutely sure to set the POWER switches on the unit and the AJ-EC3E to OFF.
- If the ECU DATA SAVE item on the <SW MODE> screen is set to OFF, the camera related settings among the adjustments and settings performed using the AJ-EC3E will be erased when the unit's POWER switch is set to OFF. In addition, it will not be possible to write this data to the setup card. It is however possible for the menu content settings to be written on the setup card. When the unit is connected once again to the AJ-EC3E, the settings of the AJ-EC3E are restored.
- When ON has been selected as the ECU DATA SAVE item setting on the <SW MODE> screen, the adjustments and settings performed using the AJ-EC3E will not be erased even when the unit's POWER switch is set to the OFF position.
- The unit's USER switch does not function when the AJ-EC3E is connected.
- When the AJ-EC3E is used to control the unit's shutter, the shutter speed settings on the unit's menu are used rather than the shutter speeds engraved on the AJ-EC3E. The correspondence between the shutter speed indications on the AJ-EC3E and the unit's shutter speed settings are shown in the table below.

AJ-EC3E shutter speed indication	Unit shutter speed setting
100 (60)	POSITION1
120	POSITION2
250	POSITION3
500	POSITION4
1000	POSITION5
2000	POSITION6

5-10 Attaching the FRONT AUDIO LEVEL control knob

When the FRONT AUDIO LEVEL control is to be operated frequently, the accessory knob can be attached to make it easier to operate the control.

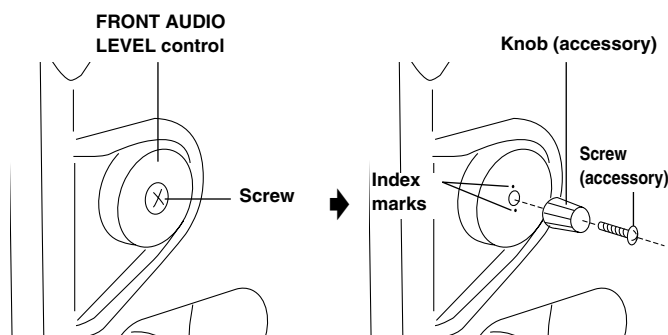

Remove the screw at the center of the FRONT AUDIO LEVEL control, and secure the accessory knob to the control and unit behind using the same screw (accessory). Make sure that the index mark on the knob side is aligned with the index mark on the control side.

Chapter 6 Maintenance and inspections

6-1 Inspections prior to shooting

Before setting off for a shooting session, perform the following inspections to verify that the system is functioning correctly. It is recommended that a color video monitor be used to check the images.

6-1-1 Preparation for inspections

- 1 Insert a fully charged battery.
- 2 Set the POWER switch to ON, and check that the HUMID display has not come on and that at least 5 segments of the BATTERY display are lighted.
 - If the HUMID display has come on, wait until it goes off.
 - If fewer than 5 segments of the BATTERY display have lighted, replace the battery with one having an adequate charge.

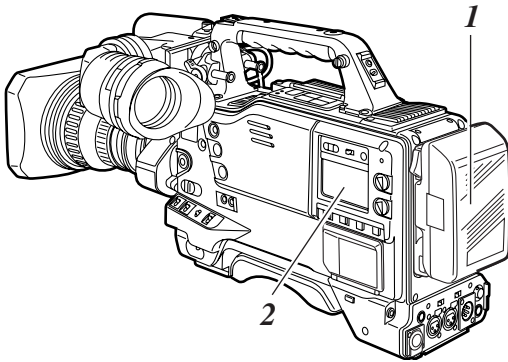

- 3 Check that there are no cables near the cassette holder or top panel, and then press the EJECT button to open the cassette holder.
- 4 After checking the following points, insert the cassette tape and close the cassette holder.
 - The cassette tape must not be set to the accidental erasure prevention mode.
 - There must be no tape slack.
 - The tape must be free from condensation.

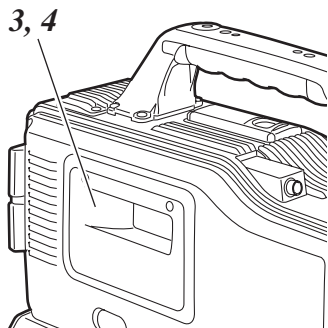

6-1-2 Inspecting the camera unit

- 1 Set the zoom to the motorized zoom mode, and check its operations in this mode.
Check that the image changes when the zoom is set to the telephoto and wide-angle positions.
- 2 Set the zoom to the manual zoom mode, and check its operations in this mode.
Turn the manual zoom lever, and check that the image changes when the zoom is set to the telephoto and wide-angle positions.
- 3 Set the aperture to the auto adjustment mode, point the lens at some objects with different brightness levels, and check that the auto aperture adjustment works.
- 4 Set the aperture to the manual adjustment mode, turn the aperture ring, and check that the manual aperture is adjusted.
- 5 While holding down the auto instantaneous aperture adjustment button, point the lens at some objects with different brightness levels, and check that the auto instantaneous aperture adjustment function works.
- 6 Return the aperture to the auto adjustment mode, switch the GAIN switch setting to L, M and H, and check that:
 - The aperture is adjusted for objects of the same brightness level in tandem with the switching of the gain setting.
 - The gain displayed on the viewfinder screen is switched in tandem with the switching of the gain setting.
- 7 When a lens with an extender has been installed, set the extender to the operating position, and check that it works properly.

Chapter 6 Maintenance and inspections

6-1-3 Inspecting the VTR unit

Perform all the steps outlined in section “1. Tape travel inspection” through section “4. Earphone and speaker inspection” one after the other.

1. Tape travel inspection

- 1** Set the VTR SAVE/STBY switch to SAVE, and check that the VTR SAVE lamp inside the viewfinder lights.
- 2** Set the VTR SAVE/STBY switch to STBY, and check that the VTR SAVE lamp goes off.
- 3** Set the TCG switch to R-RUN.
- 4** Set the DISPLAY switch to CTL.
- 5** Press the unit’s VTR START button, and check that:
 - The tape reels rotate.
 - The figure shown on the counter display changes.
 - The REC lamp inside the viewfinder lights.
 - The RF and SERVO displays do not appear in the display window.
- 6** Press the unit’s VTR START button again. Check that the tape stops and the REC lamp inside the viewfinder goes off.
- 7** Use the lens VTR button to check the same operations as in steps 5 and 6.
- 8** Press the RESET button, and check that “00:00:00:00” appears on the counter display.
- 9** Set the LIGHT switch to ON, and check that the display window illuminates.
- 10** Press the REW button, and after the tape has been rewound for a few seconds, press the PLAY/PAUSE button.
Check that the tape is recorded, played back and rewound properly.
- 11** Press the FF button, and check that the tape is fast forwarded properly.

2. Automatic audio level adjustment function inspection

- 1** Set the AUDIO SELECT CH1 and CH2 switch to AUTO.
- 2** Set the AUDIO IN CH1 and CH2 switches to FRONT.
- 3** Point the microphone connected to the MIC IN jack at a suitable sound source, and check that the changes in the level displays for both CH1 and CH2 reflect the changes in the strength of the sound.

3. Manual audio level adjustment function inspection

- 1** Set the AUDIO IN CH1 and CH2 switches to FRONT.
- 2** Set the AUDIO SELECT CH1 and CH2 switch to MAN.
- 3** Turn the AUDIO LEVEL CH1 and CH2 controls. Check that when they are turned clockwise, the level displays increase.

4. Earphone and speaker inspection

- 1** Set the VTR SAVE/STBY switch to STBY.
- 2** Turn the MONITOR control, and check that the speaker volume changes.
- 3** Connect the earphones to the PHONES jack. Check that the sound from the speaker is muted, and that the microphone’s sound is heard in the earphones.
- 4** Turn the MONITOR control, and check that the earphone volume changes.

Chapter 6 Maintenance and inspections

5. Inspection using external microphones

- 1 Connect external microphones to the AUDIO IN CH1 and CH2 jacks.
- 2 Set the AUDIO IN CH1 and CH2 switches to REAR.
- 3 Set the LINE/MIC/+48V selector switch on the back panel to MIC or +48V in accordance with the external mic's power supply type.
MIC : Internal power supply mic.
+48V : External power supply mic.
- 4 Point the microphones at the sound source, and check that the changes in the audio levels displayed on the audio level meter of the display window and in the viewfinder reflect the changes in the strength of the sound.
This inspection can also be performed for each channel by connecting one of the microphones to each channel in turn.

6. Inspections relating to the time code and user bits

- 1 Set the user bits as required.
For details on the setting procedure, refer to "4-5-1 Setting the user bits."
- 2 Set the time code.
For details on the setting procedure, refer to "4-5-3 Setting the time code."
- 3 Set the TCG switch to R-RUN.
- 4 Press the VTR START button.
Check that the figure on the counter display changes as the tape travels.
- 5 Press the VTR START button again.
Check that the tape stops and the figure shown on the counter display stops changing.
- 6 Set the TCG switch to F-RUN.
Check that the figure on the counter display changes irrespective of the tape travel.
- 7 Set the DISPLAY switch to UB.
Check that pressing the HOLD button advances the display value through the sequence VTCG → DATE → TIME → no display (time zone) → TCG.

6-1-4 Self-diagnosis function

Simplified checks can be undertaken on the unit's system at such times when, for instance, a color video monitor is not available.

Perform menu operations to open the <SYSTEM CHECK> from the MAINTENANCE page. Check the camera output level setting under the COLOR CHECK item.

```
→ < SYSTEM CHECK >
      COLOR CHECK : OFF

      Y : 0%      R : 0%
      G : 0%      B : 0%
```

Chapter 6 Maintenance and inspections

6-2 Maintenance

6-2-1 Condensation

The water vapor in the air may form as tiny droplets on the head drum when the unit is moved from a cold location to a warm location or used in a very humid place. This phenomenon is known as condensation, and running the tape under these conditions is liable to cause the tape to stick to the drum.

Note the following points:

- Remove the tape when the unit's operation is to be started in conditions where condensation may form.
- Before loading the tape, set the power switch to ON, and check that the HUMID display is not lighted in the display window.

<Note>

For safety reasons, the HUMID display will flash and the drum will rotate for 80 minutes after condensation detection is released.

During this time, the operation buttons cannot be operated.

6-2-2 Head cleaning

Use the AJ-CL12MP cleaning cassette if the heads need to be cleaned. Take care to read the instructions accompanying the cleaning tape since the video heads may be damaged if the tape is not used in the correct way.

6-2-3 Cleaning inside the viewfinder

- Do not use thinners or any other solvent to remove dirt.
 - Use a lens cleaner available on the market to wipe the lens.
 - NEVER wipe the mirror.
- If dirt or dust has found its way onto the mirror, remove it using an air blower at retail outlets.

6-2-4 Phenomena inherent to CCD cameras

Smear

This phenomenon may occur when very bright subjects are shot.

The faster the electronic shutter speed, the more likely it is that it will occur.

6-2-5 Replacing the backup battery

The backup battery is already installed when the unit is shipped.

When it has discharged, the "BACK UP BATT EMPTY" display appears for 3 seconds on the viewfinder screen when the POWER switch is set to ON.

Moreover, the time code value of the TCG will be set to "00:00:00:00" and the backup of the time code value will no longer be possible: this means that the backup battery should be replaced.

Consult with your nearest service center, and replace the spent battery with a new battery (CR2032).

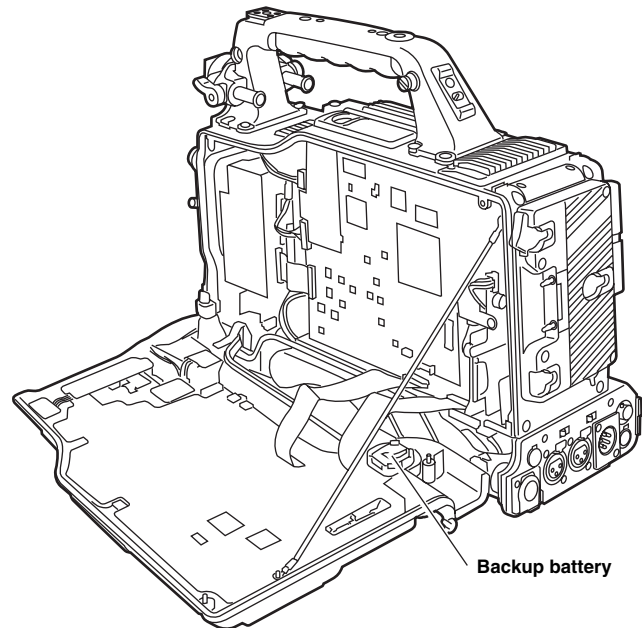

CAUTION:

These servicing instructions are for use by qualified service personnel only. To reduce the risk of electric shock, do not perform any servicing other than that contained in the operating instructions unless you are qualified to do so.

Chapter 6 Maintenance and inspections

6-2-6 Connectors and signals

DC IN	
1	GND
2	NC
3	NC
4	+12V

Matsushita part number K1AA104H0024
 Maker part number HA16RX-4P(SW1)
 (Hirose Denki)

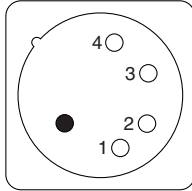

<Note>

Ensure that the polarities are used correctly for a power supply from an external source.

FRONT MIC IN	
1	GND
2	AUDIO IN(H)
3	AUDIO IN(C)

Matsushita part number K1AB103B0013
 Maker part number NC3FBH2
 (NEUTRIK)

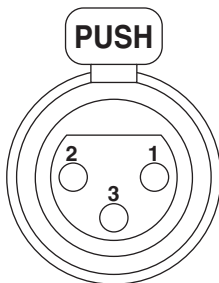

DVCPRO (IEEE 1394)	
1	NC
2	VG
3	PB -
4	PB +
5	PA -
6	PA +

Matsushita part number K1FA106E0001
 Maker part number AXJ2111502T
 (Matsushita Electric Works)

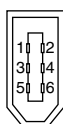

AUDIO IN	
1	GND
2	AUDIO IN(H)
3	AUDIO IN(C)

Matsushita part number K1AB103A0007
 Maker part number HA16PRM-3SG
 (Hirose Denki)

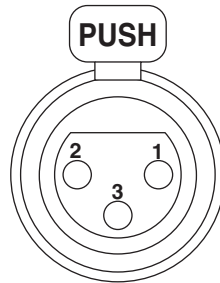

GPS	
1	GPS TXA
2	GPS RXA
3	GPS VBAT
4	START
5	GPS VCC
6	GPS GND

Matsushita part number K1AB106J0010
 Maker part number HR10A-7R-6SC
 (Hirose Denki)

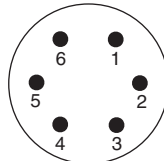

<Note>

The unit's VTR START/STOP signal is assigned to pin 4.

AUDIO OUT	
1	GND
2	L CH OUT (H)
3	L CH OUT (C)
4	R CH OUT (H)
5	R CH OUT (C)

Matsushita part number K1AA105H0007
 Maker part number HA16RD-5P
 (Hirose Denki)

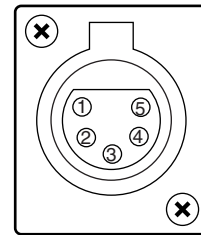

ECU	
1	CAM CONT
2	CAM DATA
3	NC
4	ECU ON
5	UNREG 12V
6	GND

Matsushita part number K1AB106J0010
 Maker part number HR10A-7R-6SC
 (Hirose Denki)

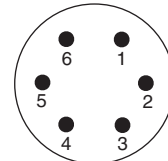

DC OUT	
1	GND
2	NC
3	NC
4	+12V OUT

Matsushita part number VJS3824A004
 Maker part number HR10A-7R-4SC
 (Hirose Denki)

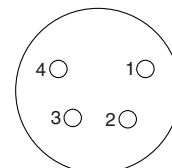

Chapter 6 Maintenance and inspections

6-3 Warning system

6-3-1 Warning description tables

When an error or a problem is detected immediately after the power is turned on or while an operation is underway, the WARNING lamp and lamps inside the viewfinder serve to alert the user.

<Note>

Items are displayed in the following sequence of priority: WARNING lamp > tally lamp > warnings inside the viewfinder. The display accords with this sequence when more than one error has occurred at the same time. However, WIRELESS RF may not be displayed depending on the menu setting selected.

1. SLACK

Indications on LCD screen	"SLACK" appears and an error code flashes.
WARNING lamp	Flashes four times a second.
Tally lamp	Flashes four times a second.
Viewfinder	"SLACK" appears and an error code lights up.
Alarm	Sounds continuously.
Warning description	Motor, solenoid or other mechanism-related trouble, etc.
VTR unit operation	Operation is stopped. Power is turned off if solenoid trouble has been detected.
Corrective action	Check "6-3-2 Error codes," and consult your nearest service center.

2. BATTERY END

Indications on LCD screen	The bar display that shows the remaining battery charge starts flashing.
WARNING lamp	Lights.
Tally lamp	Flashes once a second.
Viewfinder	BATT LED lights.
Alarm	Sounds continuously.
Warning description	The battery charge is now depleted.
VTR unit operation	All operations are stopped, and the tape is unloaded. Only cassette tape eject is accepted.
Corrective action	Replace the battery.

3. TAPE END

Indications on LCD screen	The bar display that shows the remaining tape amount starts flashing.
WARNING lamp	Lights (during stop and standby OFF).
Tally lamp	Flashes four times a second (during stop and standby OFF).
Viewfinder	"END" flashes (during stop and standby OFF).
Alarm	Sounds continuously (during stop and standby OFF).
Warning description	The tape has come to its end.
VTR unit operation	Operation is stopped during recording, playback and fast forwarding.
Corrective action	Rewind the tape or replace the cassette tape.

4. REC WARNING

Indications on LCD screen	The code 11 display lights.
WARNING lamp	Flashes four times a second (for at least 3 seconds during recording).
Tally lamp	Flashes four times a second (for at least 3 seconds during recording).
Viewfinder	REC WARNING display lights (for at least 3 seconds during recording).
Alarm	Sounds four times a second (for at least 3 seconds during recording).
Warning description	Problem with the recording control signal.
VTR unit operation	Recording continues but the signals may not be recorded correctly while the warning remains displayed.
Corrective action	Rewind the tape or replace the cassette tape.

Chapter 6 Maintenance and inspections

5. HUMID

Indications on LCD screen	"HUMID" display lights if condensation is detected. "HUMID" display flashes for an additional 10 to 90 minutes after condensation detection is canceled.
WARNING lamp	Lights for 90 minutes following the release of the condensation detection after the condensation formation was detected.
Tally lamp	Flashes 4 times per second for 90 minutes after condensation detection is canceled.
Viewfinder	"HUMID" display flashes from the time condensation is detected until 90 minutes after the condensation detection is released.
Alarm	Sounds continuously (4 times a second during recording).
Warning description	Condensation has formed.
VTR unit operation	The recording operation continues but if the tape sticks, recording will stop. For 80 minutes after the condensation detection is released, the drum is rotated and no operations are accepted.
Corrective action	Stop the tape travel and turn off the power. If the "HUMID" display fails to be cleared even when the power is turned back on, wait until it clears.

6. SERVO

Indications on LCD screen	"SERVO" display lights (during recording and playback).
WARNING lamp	Flashes four times a second (during recording and playback).
Tally lamp	Flashes four times a second (during recording and playback).
Viewfinder	"SERVO" display lights (during recording and playback).
Alarm	Sounds four times a second (during recording and playback).
Warning description	The servo is disturbed.
VTR unit operation	Operation continues but the unit may not operate correctly.
Corrective action	Turn off the power and consult your dealer. The warning display may flash for a moment and then disappear when tape transport commences: this is normal and not indicative of a failure or malfunctioning.

7. RF

Indications on LCD screen	"RF" display flashes (during standby and recording).
WARNING lamp	Flashes four times a second (during recording).
Tally lamp	Flashes four times a second (during recording).
Viewfinder	"RF" display lights (during recording).
Alarm	Sounds four times a second (during recording).
Warning description	The video heads have become clogged. There is a problem in the video system.
VTR unit operation	The cleaning rollers are activated to clean the heads (for a maximum of 10 seconds). Recording continues but the signals may not be recorded correctly. The indications on LCD screen are retained until the REC/PAUSE status is established. They go off as soon as the unit transfers from the REC/PAUSE mode to another mode.
Corrective action	Clean the heads. If the signals cannot be recorded correctly even after cleaning, consult your nearest service center.

8. 1394

Indications on LCD screen	"1394 E-**" display flashes.
WARNING lamp	Flashes four times a second (during recording).
Tally lamp	Flashes four times a second (during recording).
Viewfinder	<ul style="list-style-type: none"> When error code 92 appears, "1394 INITIAL ERROR" display lights (during standby and recording). With all other error codes or when 1394 is selected as the REC SIGNAL menu item setting, the error is not displayed in the viewfinder.
Alarm	Sounds four times a second (during recording).
Warning description	There is something wrong with the signals supplied to the DVCPRO connector.
VTR unit operation	Operation continues, but something is wrong with the signals supplied to the DVCPRO connector.
Corrective action	Check the IEEE 1394 cable and DVCPRO connector connections and the settings of the external units or menu settings, and then turn the power off and back on. If the warning display is not cleared, check "6-3-2 Error codes," and consult your nearest service center.

9. WIRELESS RF

Indications on LCD screen	No indication
WARNING lamp	Flashes four times a second (during standby and recording).
Tally lamp	Flashes four times a second (during recording).
Viewfinder	"WIRELESS RF" display lights for at least 3 seconds during recording.
Alarm	Sounds four times a second (for at least 3 seconds during standby and recording).
Warning description	Poor wireless signal reception.
VTR unit operation	Operation continues but the signals from the wireless microphone cannot be received.
Corrective action	Check the microphone's power supply and the reception condition of the receiver.

Chapter 6 Maintenance and inspections

10. BATTERY NEAR END

Indications on LCD screen	The bar display that shows the remaining battery charge starts flashing.
WARNING lamp	Flashes once a second.
Tally lamp	Flashes once a second.
Viewfinder	BATT LED starts flashing.
Alarm	Sounds four times a second.
Warning description	The battery charge is nearly depleted.
VTR unit operation	Operation continues.
Corrective action	Replace the battery when it becomes necessary.

11. TAPE NEAR END

Indications on LCD screen	The bar display that shows the remaining tape amount starts flashing.
WARNING lamp	Flashes once a second (during recording).
Tally lamp	Flashes once a second (during recording).
Viewfinder	<ul style="list-style-type: none"> The remaining tape display starts flashing (in the EE mode). "" flashes for 3 seconds one minute before the tape reaches the end.
Alarm	Sounds once a second.
Warning description	The tape is close to its end (about 2 minutes remain).
VTR unit operation	Operation continues.
Corrective action	Replace the cassette tape when it becomes necessary.

6-3-2 Error codes

One of the following error codes appears in the display window when an error has occurred in the unit for some reason.

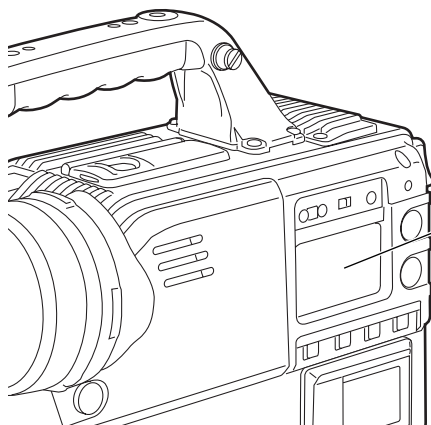

Code No.	Description of error
04	Pinch solenoid problem
08	Cleaning solenoid problem
0B	Supply reel problem
0C	Take-up reel problem
0D	Capstan problem
0E	Cylinder problem
0F	Loading problem
38	Servo transmission problem
3F	Camera transmission problem
6F	Reference signal problem
11	Video initialization problem
81	The signals supplied to the DVCPRO connector are not ×1 speed transfer signals in the DVCPRO (25 Mbps) format.
82	The signals supplied to the DVCPRO connector are not ×1 speed transfer signals in the DVCPRO50 (50 Mbps) format.
83	The video signals supplied to the DVCPRO connector are not the correct signals.
84	The signals supplied to the DVCPRO connector are not in the DVCPRO format.
87	The audio signals supplied to the DVCPRO connector are not the correct signals.
90	No signals are supplied to the DVCPRO connector.
92	Something is wrong with the DVCPRO connector connection. ("1394 INITIAL ERROR" is displayed in the viewfinder.)

Error codes (81 to 92) relating to the DVCPRO connector

When an error has occurred while recording the signals which are input to the DVCPRO connector, the error status is indicated by a code which flashes once every two seconds in the time code display area.

Even after the cause of the error is eliminated, the code continues to flash for another six seconds.

Error codes 81 to 90

When recording is paused, the applicable error code lights up on the display for as long as the MODE CHECK button is held down.

Error code 92

Whenever recording is paused, error code 92 lights up and remains lighted.

Chapter 6 Maintenance and inspections

6-3-3 Emergency eject

If the cassette cannot be ejected by pressing the EJECT button, use a screwdriver or similar tool to press and turn the emergency eject screw. This enables the cassette to be removed.

- 1 Set the power to OFF.
- 2 Remove the rubber cap where shown in the figure. Insert a Phillips head screwdriver into the cross-shaped part of the emergency eject screw (red).
- 3 While pushing in with the screwdriver, turn the emergency eject screw counterclockwise until the tape is ejected.
 - This screw needs to be rotated through about 20 turns after the first turn until the unloading can be started.
 - It also needs to be rotated through about 90 turns after the first turn until the tape is ejected.
- 4 Remove the cassette.
- 5 Return the rubber cap to its original position.

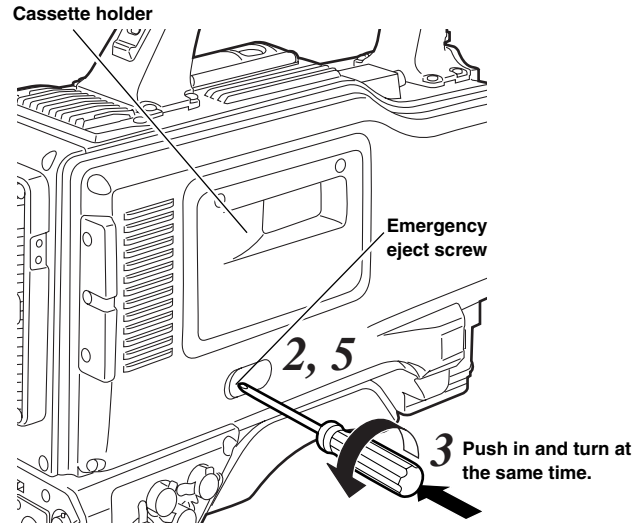

<Notes>

- Do not turn the emergency eject screw except in an emergency.
- **Do not turn the screw clockwise. Stop turning the screw as soon as the tape is ejected. Otherwise, the mechanism may be damaged.**
- After the tape is ejected, the cassette holder will not lock into place even when an attempt is made to close it. Be sure to turn the power off and turn it back on to reset the mechanism's operation, and then close the cassette holder.
- A clicking sound will be heard when the emergency eject screw is turned: this sound is made by the reel drive operation and is therefore not indicative of a malfunction.

Chapter 7 Menu description tables

7-1 Menu configuration

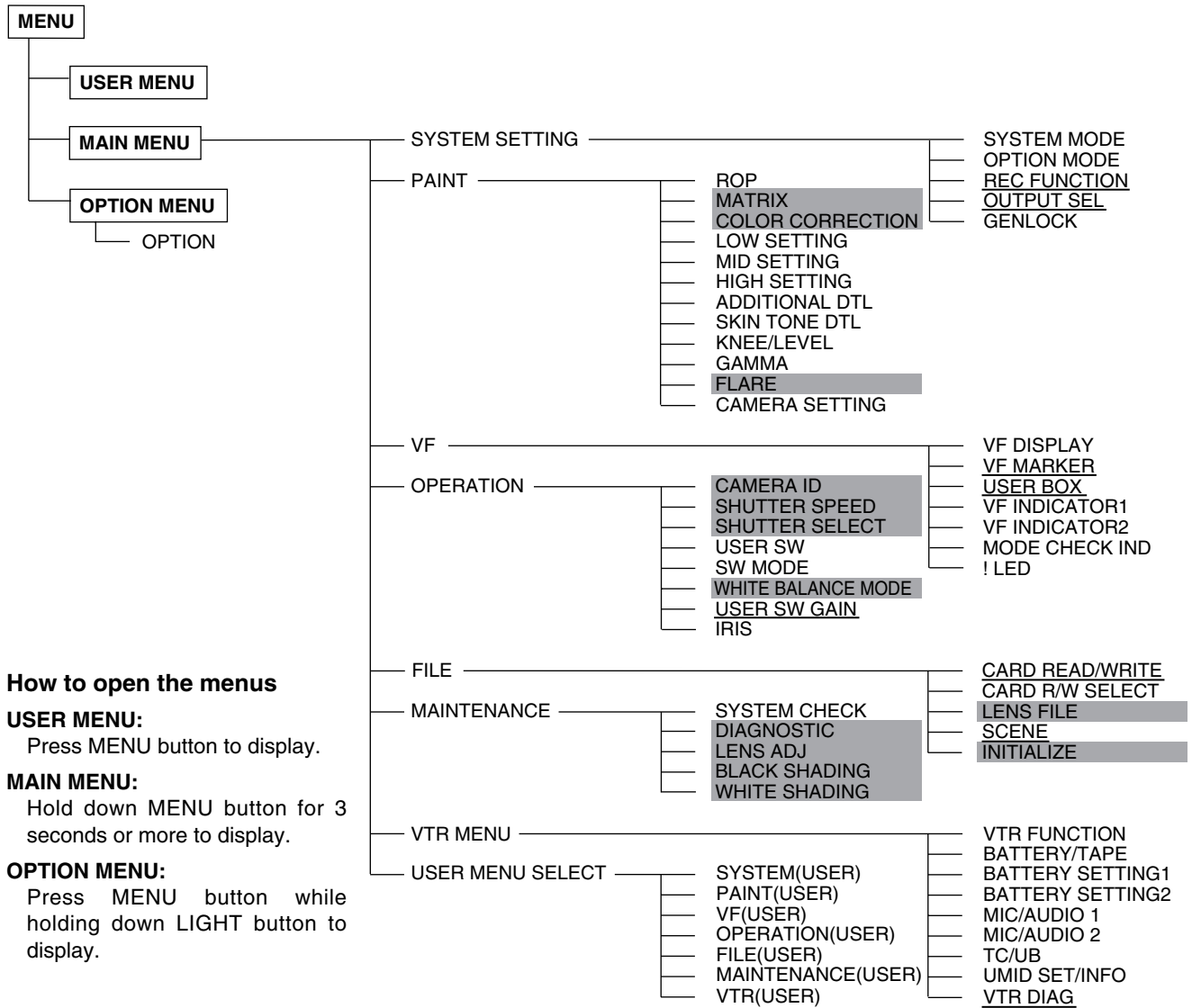

How to open the menus

USER MENU:
Press MENU button to display.

MAIN MENU:
Hold down MENU button for 3 seconds or more to display.

OPTION MENU:
Press MENU button while holding down LIGHT button to display.

<Notes>

- There is a total of 42 camera-related items on three pages (14 items per page) and 14 VTR-related items on one page which can be set.
- The items with the shading cannot be selected using <USER MENU SELECT>.
- The items with the underlining can be selected only using <USER MENU SELECT> on condition that all the items (equivalent to the number of items on one page) are selected together. Individual items cannot be selected.

How to interpret the menu lists

The following abbreviations indicate whether the menu changes are stored (written) in the corresponding data or loaded (read) from the data. The changes cannot be stored or loaded when “/” is indicated.

- S:** The changes can be stored or loaded as scene file data.
- C:** The changes can be stored or loaded using CARD READ/WRITE.
- U:** The changes can be stored or loaded as user data. Refer to sections “7-6-4 SCENE” and “7-6-5 INITIALIZE.”
- F:** The changes can be stored or loaded as READ FACTORY DATA. Refer to section “7-6-5 INITIALIZE.”
- E:** The changes can be stored or loaded using ECU DATA SAVE. Refer to section “5-9 Connecting the extension control unit (AJ-EC3E).”

Item/ Data storage	Variable range	Remarks
REC SIGNAL / C U F E	CAM VIDEO 1394	For selecting the video input signals. CAM: The signals from the camera are recorded. VIDEO: The signals ----

This column indicates the variable range in which the item can be set and the choice of the settings which can be selected for the item.

Described in this column are the operations which can be expected to result when the item's settings are selected.

Chapter 7 Menu description tables

7-2 SYSTEM SETTING

7-2-1 SYSTEM MODE

Item/ Data storage	Variable range	Remarks
REC SIGNAL C U F E	<u>CAM</u> VIDEO 1394	For selecting the video input signals. CAM: The signals from the camera are recorded. VIDEO: The signals from the GENLOCK IN connector are recorded. 1394: The signals from the DVCPRO connector are recorded. <Note> CAM is always set when the power is next turned on after it being turned off.
REC MODE SDC905 C U F E	<u>16:9/50M</u> 4:3/50M 16:9/25M 4:3/25M	For selecting the mode in which to record the signals on the VTR. 16:9/50M: <16:9> signals are recorded at 50 Mbps. 4:3/50M: <4:3> signals are recorded at 50 Mbps. 16:9/25M: <16:9> signals are recorded at 25 Mbps. 4:3/25M: <4:3> signals are recorded at 25 Mbps.
ASPECT SDC615 C U F E	<u>16:9</u> 4:3	For selecting the mode in which to record the signals on the VTR. 16:9: <16:9> signals are recorded. 4:3: <4:3> signals are recorded.
PB MODE SDC905 C U F E	MANUAL <u>AUTO</u>	For selecting the playback mode. MANUAL: The playback mode accords with the 25M or 50M setting of the REC MODE item. Operation proceeds with 16:9 or 4:3 read from the tape. AUTO: In this mode, the recording mode is automatically detected and playback is performed in the same mode.
REC TALLY C U F E	<u>RED</u> GREEN CHAR	For selecting the method used to inform the user that the unit is recording when a system using an extender or other device is configured and BOTH is selected as the 26-PIN CONTROL menu item setting while the system is used in the remote control mode. RED: The red tally lamp lights. GREEN: The green tally lamp lights. CHAR: The letters "REC" appear on the viewfinder.

The underlining in the variable range column indicates the setting in the preset mode.

Chapter 7 Menu description tables

7-2-2 OPTION MODE

Item/ Data storage	Variable range	Remarks
P.OFF GPS DATA C U F	<u>HOLD</u> <u>CLEAR</u>	For selecting whether or not to hold the UMID GPS position information while the power is off and record the information as the data still held as the previous value until another measurement can be taken after the power is next turned on. HOLD: The data is held and recorded. CLEAR: The data is cleared at the same time as the power is turned off, and all zeros (no information) are recorded from the time the power is turned on until the measurement is next taken.
COMPONENT OUT C U F	<u>ON</u> <u>OFF</u>	For selecting whether to conserve the power of the component output to peripheral units. ON: Component signals are output to the peripheral units. OFF: Output stops during power save. (Note that this setting is forced ON if a camera adapter is connected and a tally signal is detected from pin 26. Otherwise it is OFF.)
1394 SPEED C U F	<u>S100</u> <u>S200</u> <u>S400</u>	For setting the transfer speed of the signals to be output from the DVCPRO connector. S100: 100 Mbps S200: 200 Mbps S400: 400 Mbps
1394 IN CH C U F	0 : 63 <u>AUTO</u>	For setting the input channel for the signals to be output from the DVCPRO connector. 0-63: The channel is fixed at the specified number. AUTO: The channel corresponding to the setting of the externally connected unit is selected.
1394 OUT CH C U F	0 : 63 <u>AUTO</u>	For setting the output channel for the signals to be output from the DVCPRO connector 0-63: The channel is fixed at the specified number. AUTO: The channel corresponding to the setting of the externally connected unit is selected.
26PIN VIDEO SELECT C U F	<u>COMPONENT</u> <u>VIDEO OUT</u>	For setting the video signals to be output from pin #4 of the 26-pin connector when a 26-pin camera adapter is connected. COMPONENT: The component Y signal is output. VIDEO OUT: The same signal (composite signal) as the VIDEO OUT connector signal is output.

Item/ Data storage	Variable range	Remarks
26PIN CONTROL C U F	<u>OFF</u> <u>BOTH</u>	For setting whether recording is to be controlled by the unit or by both the unit and the external VTR which is connected to the 26-pin camera adapter. OFF: Recording is performed by the unit only. (It is not performed using the external VTR.) BOTH: Recording is performed by both the unit and the external VTR. The tally lamp indicates the status of the tally signal of the 26-pin connector. (The tally lamp setting can be established using REC TALLY in the SYSTEM MODE.)
26PIN CTL DEFAULT C U F	<u>NORMAL</u> <u>SPECIAL</u>	For setting the control signal of the VTR to be output from pin #12 of the 26-pin connector when using a VTR connected to a 26-pin camera adapter. NORMAL: STOP "low," START "high" (for AJ-D92) SPECIAL: STOP "high," START "low"

The underlining in the variable range column indicates the setting in the preset mode.

Chapter 7 Menu description tables

7-2-3 REC FUNCTION

Item/ Data storage	Variable range	Remarks
INTERVAL REC MODE / / / / F /	ON ONE SHOT <u>OFF</u>	For setting the INTERVAL REC function. ON (MEMORY): Interval recording is possible in single-frame units using memory. ONE SHOT: Recording is performed only once for the time set in the REC TIME item, after which it stops. OFF: Interval recording is not performed.
REC TIME SDC905 / C U F /	<u>00s01f</u> : 59s24f	For setting the recording time (one cut). The shortest time is one frame.
SDC615 / C U F /	<u>02s00f</u> : 59s24f	The shortest time is two seconds.
PAUSE TIME SDC905 / C U F /	00h00m00s01f : 00h04m59s24f : 23h59m59s24f	For setting the recording pause time. The shortest time is one frame.
SDC615 / C U F /	00h00m02s00f : 00h04m59s24f : 23h59m59s24f	The shortest time is two seconds.
TAKE TOTAL TIME / C U F /	<u>NONE</u> : 5day	For setting the time required for shooting. Select a setting from NONE (shooting continues until it is stopped manually) to 5DAY (5 days).
TOTAL REC TIME / / / / / / / /	00m00s01f : 90m59s24f OVER 100min <u>NONE</u>	For displaying the total recording time. The setting for this time cannot be changed. The total time yielded by adding the REC TIME, PAUSE TIME and TOTAL TAKE TIME is displayed.
AUDIO REC / C U F /	<u>OFF</u> ON	For setting whether or not to record the sound.
START DELAY / C U F /	<u>0SEC</u> : 10SEC	For setting the time taken until recording is to start after the REC START button is pressed in the INTERVAL REC mode.
PRE REC MODE SDC905 / C U F /	OFF 0SEC : <u>6SEC</u>	For setting the PRE REC function. OFF: The PRE REC function is not operable. 0-6SEC: The duration for which pre-recording can be performed after the REC START button is pressed is set here.
NEWS REC MODE SDC615 / C U F /	<u>OFF</u> 0.2SEC : 2.0SEC	For setting the NEWS REC time.
RETAKE MODE / / / / F /	ON <u>OFF</u>	For selecting whether or not to allow retake operations (MODE CHECK switch + RET switch).

The underlining in the variable range column indicates the setting in the preset mode.

Chapter 7 Menu description tables

7-2-4 OUTPUT SEL

Item/ Data storage	Variable range	Remarks
VIDEO OUT SEL	<u>VBS</u> VF Y	For selecting the output signal of the VIDEO OUT connector. VBS: The normal composite signal is output. VF: The viewfinder's Y signal is output. The status display is also superimposed. Y: The component Y signal is output.
OUTPUT CHAR	TC STATUS <u>MENU</u> ONLY	For setting the type of characters to be superimposed onto the output signals of the VIDEO OUT connector and MON OUT connector. TC: The time code is displayed. (The menu appears when the menu is displayed.) <Note> The time code display position moves vertically in accordance with the camera ID position. STATUS: All the same characters as the ones superimposed on the viewfinder are displayed. (The menu appears when the menu is displayed.) MENU ONLY: Only appears when the menu is displayed. Normally, nothing is displayed
MONITOR OUT CHAR	ON <u>OFF</u>	For selecting whether to superimpose characters onto the MON OUT connector signal. (It is not linked with the VIDEO OUT CHARACTER switch.) The characters which are superimposed are the ones which are selected using the OUTPUT CHAR menu item. ON: The characters are superimposed. OFF: The characters are not superimposed.
VF MODE	<u>EE/PB</u> EE	EE/PB: The images are played back in the playback mode. EE: The camera images are displayed all the time.

7-2-5 GENLOCK

Item/ Data storage	Variable range	Remarks
GENLOCK	INT EXT 26P EXT	For selecting the sync signal among the camera signals. INT: For synchronizing with the internal reference signal regardless of the reference signal which has been supplied to the GENLOCK IN connector. EXT: For synchronizing with the reference signal which has been supplied to the GENLOCK IN connector. 26P EXT: For synchronizing with the signal input via the 26-pin jack.
H PHASE COARSE	-50 : <u>+00</u> : +50	For making coarse adjustments to the horizontal phase when setting up a system.
H PHASE FINE	-128 : <u>+000</u> : +127	For making fine adjustments to the horizontal phase when setting up a system. <Note> This adjustment also affects the SC phase.
SC PHASE COARSE	0 : <u>1</u> : 3	For coarsely adjusting the SC phase during genlock.
SC PHASE FINE	-75 : <u>+00</u> : +75	For finely adjusting the SD phase during genlock. <Note> When making GENLOCK adjustments to the unit, adjust H PHASE first, followed by SC PHASE.

The underlining in the variable range column indicates the setting in the preset mode.

Chapter 7 Menu description tables

7-3 PAINT

7-3-1 ROP

Item/ Data storage	Variable range	Remarks
MASTER PED	-200 : <u>+010</u> : :	For setting the master pedestal level.
S <u>/</u> U F E	+200	
MASTER DTL	-31 : <u>+00</u> : :	For setting the H detail/V detail level.
S C U F E	+31	
MASTER GAMMA	0.35 : <u>0.45</u> : :	For setting the master gamma in 0.01 steps.
S <u>/</u> U F E	0.75	
KNEE POINT	70.0% : <u>85.0%</u> : :	For setting the master knee position in 0.5% steps.
S <u>/</u> U F E	107.0%	
KNEE SLOPE	0 : <u>50</u> : :	For setting the knee slope.
S <u>/</u> U F E	99	
R GAIN	-200 : <u>+000</u> : :	For setting the R channel gain.
S C U F E	+200	
G GAIN	-200 : <u>+000</u> : :	For setting the G channel gain.
S C U F E	+200	
B GAIN	-200 : <u>+000</u> : :	For setting the B channel gain.
S C U F E	+200	
R PEDESTAL	-100 : <u>+000</u> : :	For setting the R channel pedestal level.
S C U F E	+100	
G PEDESTAL	-100 : <u>+000</u> : :	For setting the G channel pedestal level.
S C U F E	+100	
B PEDESTAL	-100 : <u>+000</u> : :	For setting the B channel pedestal level.
S C U F E	+100	

7-3-2 MATRIX

Item/ Data storage	Variable range	Remarks
■ MATRIX TABLE	A	For selecting the color correction table used to perform the adjustments.
S C U F E	B	
MATRIX R-G	-31 : <u>+30</u> : :	For performing the R-G color adjustment.
S C U F E	+31	
MATRIX R-B	-31 : <u>+04</u> : :	For performing the R-B color adjustment.
S C U F E	+31	
MATRIX G-R	-31 : <u>+21</u> : :	For performing the G-R color adjustment.
S C U F E	+31	
MATRIX G-B	-31 : <u>+19</u> : :	For performing the G-B color adjustment.
S C U F E	+31	
MATRIX B-R	-31 : <u>+17</u> : :	For performing the B-R color adjustment.
S C U F E	+31	
MATRIX B-G	-31 : <u>-02</u> : :	For performing the B-G color adjustment.
S C U F E	+31	
■ MATRIX TABLE	OFF	For selecting the color correction table which is to take effect.
S C U F E	A B	

<Note>

Items with ■ in front of their names are set by the PAINT MENU SW (■) R/W menu items on the <CARD R/W SELECT> screen.

Items without ■ in front of their names are set by the PAINT MENU LEVEL R/W menu item.

For details, refer to "7-6-2 CARD R/W SELECT."

The underlining in the variable range column indicates the setting in the preset mode.

Chapter 7 Menu description tables

7-3-3 COLOR CORRECTION

Item/ Data storage	Variable range	Remarks
R (SAT/PHASE)	-63 :00 +63	For performing the red color correction (saturation and hue).
S C U F E		
R-Mg (SAT/PHASE)	-63 :00 +63	For performing the color correction (saturation and hue) between red and magenta.
S C U F E		
Mg (SAT/PHASE)	-63 :00 +63	For performing the magenta color correction (saturation and hue).
S C U F E		
Mg-B (SAT/PHASE)	-63 :00 +63	For performing the color correction (saturation and hue) between magenta and blue.
S C U F E		
B (SAT/PHASE)	-63 :00 +63	For performing the blue color correction (saturation and hue).
S C U F E		
B-Cy (SAT/PHASE)	-63 :00 +63	For performing the color correction (saturation and hue) between blue and cyan.
S C U F E		
Cy (SAT/PHASE)	-63 :00 +63	For performing the cyan color correction (saturation and hue).
S C U F E		
Cy-G (SAT/PHASE)	-63 :00 +63	For performing the color correction (saturation and hue) between cyan and green.
S C U F E		
G (SAT/PHASE)	-63 :00 +63	For performing the green color correction (saturation and hue).
S C U F E		
G-YI (SAT/PHASE)	-63 :00 +63	For performing the color correction (saturation and hue) between green and yellow.
S C U F E		
YI (SAT/PHASE)	-63 :00 +63	For performing the yellow color correction (saturation and hue).
S C U F E		
YI-R (SAT/PHASE)	-63 :00 +63	For performing the color correction (saturation and hue) between yellow and red.
S C U F E		
■ COLOR CORRECT	ON OFF	For selecting ON or OFF for the color correction.
S C U F E		

7-3-4 LOW SETTING

Item/ Data storage	Variable range	Remarks
■ MASTER GAIN	-3dB :0dB :30dB	For setting the master gain to -3, 0, 3, 6, 9, 12, 15, 18, 21, 24, 27 or 30 dB.
S C U F E		
H.DTL LEVEL	00 :17 :63	For performing the H.DTL LEVEL setting.
S C U F E		
V.DTL LEVEL	00 :24 :31	For performing the V.DTL LEVEL setting.
S C U F E		
DTL CORING	00 :02 :15	For performing the DTL CORING setting.
S C U F E		
H.DTL FREQ.	00 :20 :31	For performing the H.DTL FREQ setting.
S C U F E		
LEVEL DEPEND.	0 :1 :5	For performing the LEVEL DEPEND setting.
S C U F E		
MASTER GAMMA	0.35 :0.45 :0.75	For setting the MASTER GAMMA in 0.01 steps.
S C U F E		
BLACK STRECH	-3 :OFF :3	For setting the gamma curve of the dark areas.
S C U F E		
■ MATRIX TABLE	OFF A B	For selecting the color correction table.
S C U F E		
■ COLOR CORRECT	ON OFF	For selecting ON or OFF for the color correction.
S C U F E		

<Note>

Items with ■ in front of their names are set by the PAINT MENU SW (■) R/W menu items on the <CARD R/W SELECT> screen.

Items without ■ in front of their names are set by the PAINT MENU LEVEL R/W menu item.

For details, refer to "7-6-2 CARD R/W SELECT."

The underlining in the variable range column indicates the setting in the preset mode.

Chapter 7 Menu description tables

7-3-5 MID SETTING

Item/ Data storage	Variable range	Remarks
■ MASTER GAIN	-3dB : 9dB : 30dB	For setting the master gain to -3, 0, 3, 6, 9, 12, 15, 18, 21, 24, 27 or 30 dB.
S C U F E		
H.DTL LEVEL	00 : 14 : 63	For performing the H.DTL LEVEL setting.
S C U F E		
V.DTL LEVEL	00 : 20 : 31	For performing the V.DTL LEVEL setting.
S C U F E		
DTL CORING	00 : 03 : 15	For performing the DTL CORING setting.
S C U F E		
H.DTL FREQ.	00 : 20 : 31	For performing the H.DTL FREQ setting.
S C U F E		
LEVEL DEPEND.	0 : 1 : 5	For performing the LEVEL DEPEND setting.
S C U F E		
MASTER GAMMA	0.35 : 0.45 : 0.75	For setting the MASTER GAMMA in 0.01 steps.
S C U F E		
BLACK STRECH	-3 : OFF : +3	For setting the gamma curve of the dark areas.
S C U F E		
■ MATRIX TABLE	OFF A B	For selecting the color correction table.
S C U F E		
■ COLOR CORRECT	ON OFF	For selecting ON or OFF for the color correction.
S C U F E		

7-3-6 HIGH SETTING

Item/ Data storage	Variable range	Remarks
■ MASTER GAIN	-3dB : 18dB : 30dB	For setting the master gain to -3, 0, 3, 6, 9, 12, 15, 18, 21, 24, 27 or 30 dB.
S C U F E		
H.DTL LEVEL	00 : 12 : 63	For performing the H.DTL LEVEL setting.
S C U F E		
V.DTL LEVEL	00 : 17 : 31	For performing the V.DTL LEVEL setting.
S C U F E		
DTL CORING	00 : 08 : 15	For performing the DTL CORING setting.
S C U F E		
H.DTL FREQ.	00 : 20 : 31	For performing the H.DTL FREQ setting.
S C U F E		
LEVEL DEPEND.	0 : 2 : 5	For performing the LEVEL DEPEND setting.
S C U F E		
MASTER GAMMA	0.35 : 0.55 : 0.75	For setting the MASTER GAMMA in 0.01 steps.
S C U F E		
BLACK STRECH	-3 : OFF : +3	For setting the gamma curve of the dark areas.
S C U F E		
■ MATRIX TABLE	OFF A B	For selecting the color correction table.
S C U F E		
■ COLOR CORRECT	ON OFF	For selecting ON or OFF for the color correction.
S C U F E		

<Note>

Items with ■ in front of their names are set by the PAINT MENU SW (■) R/W menu items on the <CARD R/W SELECT> screen.

Items without ■ in front of their names are set by the PAINT MENU LEVEL R/W menu item.

For details, refer to "7-6-2 CARD R/W SELECT."

The underlining in the variable range column indicates the setting in the preset mode.

Chapter 7 Menu description tables

7-3-7 ADDITIONAL DTL

Item/ Data storage	Variable range	Remarks
KNEE APE LVL	OFF 1 2 5	For performing the KNEE APE LEVEL setting.
S C U F E		
CHROMA DTL	<u>OFF</u> 1 5	For performing the CHROMA DTL setting. The chroma edge is detected and placed on the Y signal to bolster H.DTL. The higher the number, the greater the correction.
S C U F E		
DTL GAIN(+)	-31 +00 +31	For changing the DTL "+" direction level.
S C U F E		
DTL GAIN(-)	-31 +00 +31	For changing the DTL "-" (down) direction level.
S C U F E		
DTL CLIP	00 63	For changing the level at which the maximum value of the DTL signal is clipped.
S C U F E		
DTL SOURCE	(R+G)/2 (G+B)/2 2G+R+B/4 (3G+R)/4 R G	For setting the signal source of the DTL signal components.
S C U F E		
H.DTL LINE MIX	1H 2H	For setting the scanning lines for generating the H.DTL signal.
S C U F E		
■ CORNER DTL	ON OFF	For selecting ON or OFF for the mode in which the resolution is improved in the corners of the screen.
S C U F E		

<Note>

Items with ■ in front of their names are set by the PAINT MENU SW (■) R/W menu items on the <CARD R/W SELECT> screen.

Items without ■ in front of their names are set by the PAINT MENU LEVEL R/W menu item.

For details, refer to "7-6-2 CARD R/W SELECT."

7-3-8 SKIN TONE DTL

Item/ Data storage	Variable range	Remarks
■ SKIN TONE DTL	ON OFF	For selecting ON or OFF for the skin tone DTL.
S C U F E		
SKIN TONE ZEBRA	ON OFF	For selecting ON or OFF for ZEBRA in the SKIN TONE range.
S C U F E		
■ SKIN DTL CORING	0 5 7	For setting the SKIN TONE DTL coring effect.
S C U F E		
SKIN TONE GET	—	This item is executed when determining the hue which is to serve as the SKIN TONE DTL reference. Align the center marker with the subject serving as the reference, and then execute. <Note> When SKIN TONE GET is executed, the settings on the MATRIX screen and COLOR CORRECTION screen are canceled.
S C U F E		
Y MAX	000 190 255	For setting the maximum luminance signal value for applying the SKIN TONE effect.
S C U F E		
Y MIN	000 010 255	For setting the minimum luminance signal value for applying the SKIN TONE effect.
S C U F E		
I CENTER	000 022 255	For setting the center position on the I axis (setting the area to which the SKIN TONE effect is to be applied).
S C U F E		
I WIDTH	000 010 255	For setting the width of the area to which the SKIN TONE effect is to be applied on the I axis centered on the I CENTER.
S C U F E		
Q WIDTH	000 005 255	For setting the width of the area to which the SKIN TONE effect is to be applied on the Q axis centered on the I CENTER.
S C U F E		
Q PHASE	-128 +00 +127	For setting the phase of the area to which the SKIN TONE effect is to be applied as referenced to the Q axis.
S C U F E		

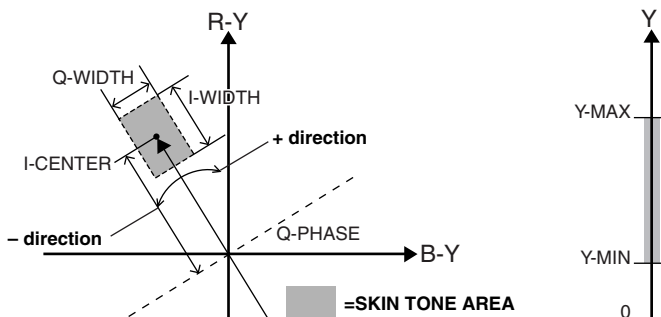

The underlining in the variable range column indicates the setting in the preset mode.

Chapter 7 Menu description tables

7-3-9 KNEE/LEVEL

Item/ Data storage	Variable range	Remarks
MASTER PED S C U F E	-200 :010 +200	For performing the MASTER PEDESTAL setting.
■ MANUAL KNEE S C U F E	ON OFF	For setting the mode which is to be established when the AUTO KNEE switch is at OFF. The KNEE POINT/SLOPE setting value is active when ON is selected.
KNEE POINT S C U F E	70.0% :85.0% 107.0%	For setting the KNEE POINT position in 0.5% steps.
KNEE SLOPE S C U F E	00 :50 99 (98)	For performing the KNEE width setting. Same as KNEE OFF when set to 0. <Note> The range of values that can be selected using the AJ-EC3E is 00 to 98.
■ WHITE CLIP S C U F E	ON OFF	For selecting ON or OFF for the WHITE CLIP function. The WHITE CLIP LVL setting value is active when ON is selected.
WHITE CLIP LVL S C U F E	90% :105% 109%	For performing the WHITE CLIP LEVEL setting.
A.KNEE POINT S C U F E	80% :85% 107%	For setting the AUTO KNEE POINT position in 0.5% steps. This item is active when the OUTPUT/AUTO KNEE selector switch is set to CAM.AUTO KNEE ON.
A.KNEE LVL S C U F E	100 :105 109	For performing the AUTO KNEE level setting.
A.KNEE RESPONSE S C U F E	1 :4	For setting the AUTO KNEE response speed.

<Note>

Items with ■ in front of their names are set by the PAINT MENU SW (■) R/W menu items on the <CARD R/W SELECT> screen.

Items without ■ in front of their names are set by the PAINT MENU LEVEL R/W menu item.

For details, refer to "7-6-2 CARD R/W SELECT."

7-3-10 GAMMA

Item/ Data storage	Variable range	Remarks
MASTER GAMMA S / U F E	0.35 :0.45 0.75	For setting the MASTER GAMMA in 0.01 steps.
R GAMMA S C U F E	-15 :00 +15	For setting the R channel GAMMA.
B GAMMA S C U F E	-15 :00 +15	For setting the B channel GAMMA.

7-3-11 FLARE

Item/ Data storage	Variable range	Remarks
R FLARE S C U F E	000 :100	For performing the R FLARE setting.
G FLARE S C U F E	000 :100	For performing the G FLARE setting.
B FLARE S C U F E	000 :100	For performing the B FLARE setting.



The underlining in the variable range column indicates the setting in the preset mode.

Chapter 7 Menu description tables

7-3-12 CAMERA SETTINGS

Item/ Data storage	Variable range	Remarks
DETAIL	ON OFF	For selecting ON or OFF for DTL (H, V).
S C U F E		
2D LPF	ON OFF	For selecting ON or OFF for the 2-dimensional LPF that reduces cross color.
S C U F E		
HIGH COLOR	ON OFF	For selecting ON or OFF for the mode in which the dynamic range of the colors is expanded.
S C U F E		
GAMMA	ON OFF	For selecting ON or OFF for the gamma circuit.
S C U F E		
TEST SAW	ON OFF	For selecting ON or OFF for the test signals.
S C U F E		
FLARE	ON OFF	For selecting ON or OFF for the flare compensation.
S C U F E		
H-F COMPE.	ON OFF	For selecting ON or OFF for the mode in which the wide-band DTL is increased.
S C U F E		

Zebra pattern display

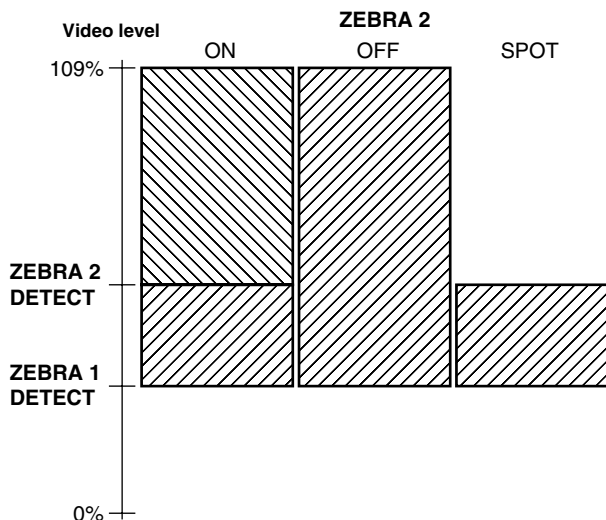

7-4 VF

7-4-1 VF DISPLAYS

Item/ Data storage	Variable range	Remarks
DISP CONDITION	NORMAL HOLD	NORMAL: The statuses are displayed at all times. HOLD: The statuses are displayed only when the MODE CHECK switch is pressed.
∕ C U F E		
DISP MODE	1 2 3	For performing the DISP MODE setting. This item is used to select the camera's warning or message displays. For details, refer to "4-7-4 Display modes and setting changes/adjustment result messages."
∕ C U F E		
VF OUT	Y NAM R G B	For selecting the VF output. Y: Luminance signal NAM: The signal with the highest level among the R, G and B signals is output. R: R channel signal G: G channel signal B: B channel signal
∕ C U F E		
VF DTL	0 3 5	For performing the VF DTL selection. This item is used to further emphasize the DTL of the VF signals. If 0 is set, the DTL will be the same as that of the main line signals.
∕ C U F E		
ZEBRA1 DETECT	0% 70% 109%	For setting the ZEBRA1 detection level (IRE level).
∕ C U F E		
ZEBRA2 DETECT	0% 85% 109%	For setting the ZEBRA2 detection level (IRE level).
∕ C U F E		
ZEBRA2	ON SPOT OFF	For selecting ON or OFF for ZEBRA2 or selecting SPOT.
∕ C U F E		
LOW LIGHT LVL	OFF 10% 15% 20% 25% 30% 35%	For setting how much lower the camera's input light quantity should be in order for "LOW LIGHT" to be displayed.
∕ C U F E		
ECU MENU DISP.	ON OFF	For selecting ON or OFF for displaying the MENU on the viewfinder when the ECU is connected.
∕ C U F E		
50M INDICATOR SDC905	ON OFF	For selecting ON or OFF for the displays during 50M recording.
∕ C U F E		
MARKER/ CHAR LVL	50% 60% 70% 80% 90% 100%	For setting the brightness of the markers and characters displayed in the viewfinder.
∕ C U F E		

The underlining in the variable range column indicates the setting in the preset mode.

Chapter 7 Menu description tables

7-4-2 VF MARKER

Item/ Data storage	Variable range	Remarks
TABLE	A B	For selecting the VF MARKER setting table. This item is used to set the current values of table A or B which have been selected using the menu items listed below.
<input type="checkbox"/> C <input type="checkbox"/> U <input type="checkbox"/> F <input type="checkbox"/> E		
CENTER MARK	OFF 1 2 3 4	For selecting the center marker. OFF: The center marker is not displayed. 1: + (large) 2: Center blank (large) 3: + (small) 4: Center blank (small)
<input type="checkbox"/> C <input type="checkbox"/> U <input type="checkbox"/> F <input type="checkbox"/> E		
SAFETY ZONE	OFF 1 2	For selecting the type of safety zone frame. OFF: The safety zone frame is not displayed. 1: Box 2: Corner frames
<input type="checkbox"/> C <input type="checkbox"/> U <input type="checkbox"/> F <input type="checkbox"/> E		
SAFETY AREA	80% 90% 100%	For setting the position of the safety zone.
<input type="checkbox"/> C <input type="checkbox"/> U <input type="checkbox"/> F <input type="checkbox"/> E		
FRAME SIG	4:3 13:9 14:9 VISTA	For setting the frame marker. Note that this setting takes effect only when REC MODE is set to 16:9. The VISTA setting is 16:8.65.
<input type="checkbox"/> C <input type="checkbox"/> U <input type="checkbox"/> F <input type="checkbox"/> E		
FRAME MARK	ON OFF	For selecting ON or OFF for the frame marker.
<input type="checkbox"/> C <input type="checkbox"/> U <input type="checkbox"/> F <input type="checkbox"/> E		
FRAME LVL	00 15	For setting the level of the frame marker. 0: Equivalent to signal OFF 15: Same brightness as center area However, this setting has no effect if FRAME SIG is set to VISTA.
<input type="checkbox"/> C <input type="checkbox"/> U <input type="checkbox"/> F <input type="checkbox"/> E		

7-4-3 USER BOX

Item/ Data storage	Variable range	Remarks
USER BOX	ON OFF	For setting whether or not to display the user box.
<input type="checkbox"/> C <input type="checkbox"/> U <input type="checkbox"/> F <input type="checkbox"/> E		
USER BOX WIDTH	001 013 100	For setting the horizontal width of the user box.
<input type="checkbox"/> C <input type="checkbox"/> U <input type="checkbox"/> F <input type="checkbox"/> E		
USER BOX HEIGHT	001 013 144	For setting the vertical height of the user box.
<input type="checkbox"/> C <input type="checkbox"/> U <input type="checkbox"/> F <input type="checkbox"/> E		
USER BOX H POS	-50 +00 +50	For setting the horizontal position of the user box center.
<input type="checkbox"/> C <input type="checkbox"/> U <input type="checkbox"/> F <input type="checkbox"/> E		
USER BOX V POS	-144 +000 +144	For setting the vertical position of the user box center.
<input type="checkbox"/> C <input type="checkbox"/> U <input type="checkbox"/> F <input type="checkbox"/> E		

7-4-4 VF INDICATOR1

Item/ Data storage	Variable range	Remarks
EXTENDER	ON OFF	For selecting ON or OFF for the extender display.
<input type="checkbox"/> C <input type="checkbox"/> U <input type="checkbox"/> F <input type="checkbox"/> E		
SHUTTER	ON OFF	For selecting ON or OFF for the shutter speed display.
<input type="checkbox"/> C <input type="checkbox"/> U <input type="checkbox"/> F <input type="checkbox"/> E		
FILTER	ON OFF	For selecting ON or OFF for the filter No. display.
<input type="checkbox"/> C <input type="checkbox"/> U <input type="checkbox"/> F <input type="checkbox"/> E		
WHITE	ON OFF	For selecting ON or OFF for the AWB PRE/A/B display.
<input type="checkbox"/> C <input type="checkbox"/> U <input type="checkbox"/> F <input type="checkbox"/> E		
GAIN	ON OFF	For selecting ON or OFF for the currently selected gain, S.GAIN and DS.GAIN display.
<input type="checkbox"/> C <input type="checkbox"/> U <input type="checkbox"/> F <input type="checkbox"/> E		
IRIS	OFF IRIS S+IRIS S	OFF: Neither the super iris ON status nor the aperture value is displayed. IRIS: Only the aperture value is displayed. S+IRIS: Both the super iris ON status and aperture value are displayed. S: The super iris ON status is displayed. (The display or non-display of the aperture value and that of the iris override are linked.)
<input type="checkbox"/> C <input type="checkbox"/> U <input type="checkbox"/> F <input type="checkbox"/> E		
CAMERA ID	BAR CAM ALWAYS OFF	For setting the ID configuration during recording. BAR: The ID is recorded when color bar signals are provided. CAM: The ID is recorded when the camera images are provided. ALWAYS: The ID is recorded at all times. OFF: The ID is not recorded at any time. <Note> If ON is selected as the ID MIX INH menu item setting on the OPTION screen, it is not possible to record the camera ID when the images of the camera are to be recorded even if CAM or ALWAYS is selected as this menu item's setting.
<input type="checkbox"/> C <input type="checkbox"/> U <input type="checkbox"/> F <input type="checkbox"/> E		
ID POSITION	UPPER R UPPER L LOWER R LOWER L	For setting the location where the camera ID is to be recorded. UPPER R: Top right UPPER L: Top left LOWER R: Bottom right LOWER L: Bottom left
<input type="checkbox"/> C <input type="checkbox"/> U <input type="checkbox"/> F <input type="checkbox"/> E		
DATE/TIME	ON OFF	For specifying whether or not the date and time are mixed simultaneously when the CAMERA ID is recorded.
<input type="checkbox"/> C <input type="checkbox"/> U <input type="checkbox"/> F <input type="checkbox"/> E		
ZOOM LVL	ON OFF	For selecting ON or OFF for the zoom position display.
<input type="checkbox"/> C <input type="checkbox"/> U <input type="checkbox"/> F <input type="checkbox"/> E		
COLOR TEMP	ON OFF	For selecting ON or OFF for the color temperature display.
<input type="checkbox"/> C <input type="checkbox"/> U <input type="checkbox"/> F <input type="checkbox"/> E		

The underlining in the variable range column indicates the setting in the preset mode.

Chapter 7 Menu description tables

7-4-5 VF INDICATOR2

Item/ Data storage	Variable range	Remarks
TAPE / C U F E	ON OFF	For selecting ON or OFF for the remaining tape amount display.
BATTERY / C U F E	ON OFF	For selecting ON or OFF for the battery voltage display.
AUDIO LVL / C U F E	ON OFF	For selecting ON or OFF for the audio level meter display.
TC / C U F E	TCG TCR TCG/TCR OFF	For selecting the time code which is to be displayed. TCG: The time code generator value is displayed in the E-E mode. TCR: The time code reader value is displayed in the V-V mode. TCG/TCR: The time code generator value is displayed in the E-E mode, and the time code reader value is displayed in the V-V mode. OFF: The time code is not displayed at any time.
VTR WARNING / C U F E	ALWAYS NORMAL OFF	For selecting how VTR warnings are displayed. ALWAYS: It is displayed every time a warning has occurred. NORMAL: It is displayed for 3 seconds when a warning has occurred and also for 3 seconds after recording has started and after recording has finished. OFF: It is not displayed at any time.
SAVE LED / C U F E	SAVE& TAPE SAVE	For setting the operation of the SAVE lamp. SAVE&TAPE: The lamp lights up when the VTR SAVE/STBY switch has been set to the SAVE position. It is off during recording. As the tape is approaching the end, it starts flashing in tandem with the warning alarm. SAVE: The lamp lights up when the VTR SAVE/STBY switch has been set to the SAVE position. It is off during recording.

7-4-6 MODE CHECK IND

Item/ Data storage	Variable range	Remarks
STATUS / C U F E	ON OFF	For setting whether or not to display the status when the MODE CHECK switch is used.
!LED / C U F E	ON OFF	For setting whether or not to display the cause display screen if the !LED has lighted when the MODE CHECK switch is used.
FUNCTION / / / / /	ON OFF	For setting whether or not to display the function display screen when the MODE CHECK switch is used.
AUDIO / C U F E	ON OFF	For setting whether or not to display the audio display screen when the MODE CHECK switch is used.
P.ON IND / C U F E	ON OFF	For setting whether or not to display the status display screen after the power has been turned on.

7-4-7 !LED

Item/ Data storage	Variable range	Remarks
GAIN(0dB) / C U F E	ON OFF	For selecting whether or not the display is to come on when the gain is other than 0 dB.
GAIN(-3dB) / C U F E	ON OFF	For selecting whether or not the display is to come on when the gain is other than -3 dB.
DS.GAIN / C U F E	ON OFF	For selecting whether or not the display is to come on when the DS.GAIN (cumulative gain) has been entered.
SHUTTER / C U F E	ON OFF	For selecting whether or not the display is to come on when the shutter is ON.
WHITE PRESET / C U F E	ON OFF	For selecting whether or not the display is to come on when the AWB CH is set to PRESET.
EXTENDER / C U F E	ON OFF	For selecting whether or not the display is to come on when the lens is in the extender mode.
BLACK STR / C U F E	ON OFF	For selecting whether or not the display is to come on when BLACK STRETCH is being used.
MATRIX / C U F E	ON OFF	For selecting whether or not the display is to come on when MATRIX is ON.
COLOR CORRECTION / C U F E	ON OFF	For selecting whether or not the display is to come on when COLOR CORRECTION is ON.
FILTER / C U F E	ON OFF	For selecting whether or not the display is to come on when a filter other than the 3200K filter is selected.
SUPER V / C U F E	ON OFF	For selecting whether or not the display is to come on when SUPER V is ON.
25M/50M SDC905 / C U F E	OFF 25M 50M	For selecting whether or not the display is to come on when the 25M or 50M mode is established.
ATW / C U F E	ON OFF	For selecting whether or not the display is to come on when ATW is ON.
D.ZOOM / C U F E	ON OFF	For selecting whether or not the display is to come on during digital zoom operations.

<Note>

When "ON" has been selected for both the GAIN (0 dB) and GAIN (-3 dB) settings, the GAIN lamp will light when the gain is neither 0 dB nor -3 dB.

Chapter 7 Menu description tables

7-5 OPERATION

7-5-1 CAMERA ID

Item/ Data storage	Variable range	Remarks
ID1: C U F E	*****	CAMERA ID setting 1
ID2: C U F E	*****	CAMERA ID setting 2
ID3: C U F E	*****	CAMERA ID setting 3

<Note>

If READ FACTORY DATA is selected, this setting will be cleared.

7-5-2 SHUTTER SPEED

Item/ Data storage	Variable range	Remarks
SYNCHRO SCAN C U F E	ON OFF	For selecting SYNCHRO SCAN as the shutter speed to be used.
SUPER V C U F E	ON OFF	For selecting SUPER V as the shutter speed to be used.
POSITION1 C U F E	ON OFF	For selecting POSITION1 as the shutter speed to be used.
POSITION2 C U F E	ON OFF	For selecting POSITION2 as the shutter speed to be used.
POSITION3 C U F E	ON OFF	For selecting POSITION3 as the shutter speed to be used.
POSITION4 C U F E	ON OFF	For selecting POSITION4 as the shutter speed to be used.
POSITION5 C U F E	ON OFF	For selecting POSITION5 as the shutter speed to be used.
POSITION6 C U F E	ON OFF	For selecting POSITION6 as the shutter speed to be used.

7-5-3 SHUTTER SELECT

Item/ Data storage	Variable range	Remarks
SUPER V MODE C U F E	FRM1 FRM2	For selecting the SUPER V mode switching. FRM1: Normal mode FRM2: After image reduction mode <Note> In the SUPER V mode, the signals of the photodiodes in the vertical direction of the CCDs are not mixed with the output signals so that the vertical resolution is enhanced. The storage time is 1/30 sec. at the FRM1 setting and 1/60 sec. at the FRM2 setting where the sensitivity is halved.
POSITION1 SEL C U F E	1/60 1/120 1/250 1/500 1/1000 1/2000	For selecting the shutter speed.
POSITION2 SEL C U F E	1/60 1/120 1/250 1/500 1/1000 1/2000	For selecting the shutter speed.
POSITION3 SEL C U F E	1/60 1/120 1/250 1/500 1/1000 1/2000	For selecting the shutter speed.
POSITION4 SEL C U F E	1/60 1/120 1/250 1/500 1/1000 1/2000	For selecting the shutter speed.
POSITION5 SEL C U F E	1/60 1/120 1/250 1/500 1/1000 1/2000	For selecting the shutter speed.
POSITION6 SEL C U F E	1/60 1/120 1/250 1/500 1/1000 1/2000	For selecting the shutter speed.

7

The underlining in the variable range column indicates the setting in the preset mode.

Chapter 7 Menu description tables

7-5-4 USER SW

Item/ Data storage	Variable range	Remarks					
USER MAIN SW	INH S.GAIN DS.GAIN S.IRIS I.OVR S.BLK B.STR AUDIO CH1 AUDIO CH2 REC SW Y GET RET SW ATW D.ZOOM	For allocating the USER MAIN switch function.					
<table border="1" style="width: 100%; text-align: center;"> <tr><td> </td><td>C</td><td>U</td><td>F</td><td>E</td></tr> </table>		C	U	F	E		
	C	U	F	E			
USER1 SW	INH S.GAIN DS.GAIN S.IRIS I.OVR S.BLK B.STR AUDIO CH1 AUDIO CH2 REC SW Y GET RET SW ATW D.ZOOM	For allocating the USER1 switch function.					
<table border="1" style="width: 100%; text-align: center;"> <tr><td> </td><td>C</td><td>U</td><td>F</td><td>E</td></tr> </table>		C	U	F	E		
	C	U	F	E			
USER2 SW	INH S.GAIN DS.GAIN S.IRIS I.OVR S.BLK B.STR AUDIO CH1 AUDIO CH2 REC SW Y GET RET SW ATW D.ZOOM	For allocating the USER2 switch function.					
<table border="1" style="width: 100%; text-align: center;"> <tr><td> </td><td>C</td><td>U</td><td>F</td><td>E</td></tr> </table>		C	U	F	E		
	C	U	F	E			

7-5-5 SW MODE

Item/ Data storage	Variable range	Remarks					
RET SW	REC CHECK CAM RET	For selecting the RET switch function. REC CHECK: The REC CHECK operation is performed. CAM RET: The return signal output operation is performed.					
<table border="1" style="width: 100%; text-align: center;"> <tr><td> </td><td>C</td><td>U</td><td>F</td><td>E</td></tr> </table>		C	U	F	E		
	C	U	F	E			
S.BLK LVL	OFF -10 -20 -30	For setting the super black level.					
<table border="1" style="width: 100%; text-align: center;"> <tr><td> </td><td>C</td><td>U</td><td>F</td><td>E</td></tr> </table>		C	U	F	E		
	C	U	F	E			
AUTO KNEE SW	ON OFF	For selecting whether or not the AUTO KNEE switch is to be used.					
<table border="1" style="width: 100%; text-align: center;"> <tr><td> </td><td>C</td><td>U</td><td>F</td><td>E</td></tr> </table>		C	U	F	E		
	C	U	F	E			
SHD,ABB SW CTL	ON OFF	For selecting whether or not digital dark shading is to be activated by pressing the ABS switch for a prolonged time (at least 8 seconds).					
<table border="1" style="width: 100%; text-align: center;"> <tr><td> </td><td>C</td><td>U</td><td>F</td><td>E</td></tr> </table>		C	U	F	E		
	C	U	F	E			
COLOR BARS	SMPTE FULL BARS SPLIT	For selecting the color bars to be used. SMPTE: SMPTE color bars FULL BARS: Full color bars SPLIT: SPLIT color bars					
<table border="1" style="width: 100%; text-align: center;"> <tr><td> </td><td>C</td><td>U</td><td>F</td><td>E</td></tr> </table>		C	U	F	E		
	C	U	F	E			
S.GAIN OFF	L/M/H S.GAIN	For selecting the method used to release the super gain mode. L/M/H: The mode is released by making a change in the L/M/H switch position. S.GAIN: The mode is released using only the S.GAIN switch (USER switch).					
<table border="1" style="width: 100%; text-align: center;"> <tr><td> </td><td>C</td><td>U</td><td>F</td><td>E</td></tr> </table>		C	U	F	E		
	C	U	F	E			
DS.GAIN OFF	L/M/H DS.GAIN	For selecting the method used to release the digital super gain mode (cumulative gain). L/M/H: The mode is released by making a change in the L/M/H switch position. DS.GAIN: The mode is released using only the DS.GAIN switch (USER switch).					
<table border="1" style="width: 100%; text-align: center;"> <tr><td> </td><td>C</td><td>U</td><td>F</td><td>E</td></tr> </table>		C	U	F	E		
	C	U	F	E			
ECU DATA SAVE	ON OFF	ON: The settings controlled by the ECU are stored in the memory when the ECU is disconnected from the camera recorder. OFF: No camera related settings are stored in memory.					
<table border="1" style="width: 100%; text-align: center;"> <tr><td> </td><td>C</td><td>U</td><td>F</td><td>E</td></tr> </table>		C	U	F	E		
	C	U	F	E			

The underlining in the variable range column indicates the setting in the preset mode.

Chapter 7 Menu description tables

7-5-6 WHITE BALANCE MODE

Item/ Data storage	Variable range	Remarks
FILTER INH	ON OFF	For selecting whether or not to keep the AWB memory (Ach, Bch) data for each filter. ON: The data is kept in the two Ach and Bch memories for each filter used. OFF: The data is kept for each filter.
<input type="checkbox"/> C <input type="checkbox"/> U <input type="checkbox"/> F <input type="checkbox"/> E		
SHOCKLESS AWB	OFF FAST NORMAL SLOW1 SLOW2 SLOW3	For selecting ON (FAST/NORMAL/SLOW1-3) or OFF for SHOCKLESS AWB which ensures that the setting of the white balance switch to PRST, A or B is not accompanied by a shock. In addition, the switching time can be selected.
<input type="checkbox"/> C <input type="checkbox"/> U <input type="checkbox"/> F <input type="checkbox"/> E		
AWB AREA	25% 50% 90%	For selecting the AWB detection area. 25%: An area near the screen center equivalent to 25% of the screen is detected. 50%: An area near the screen center equivalent to 50% of the screen is detected. 90%: An area equivalent to 90% of the screen is detected.
<input type="checkbox"/> C <input type="checkbox"/> U <input type="checkbox"/> F <input type="checkbox"/> E		
AWB & ABB OFFSET	ON OFF	For selecting whether or not to reset the GAIN and PED values on the ROP menu when AWB or ABB is executed. ON: The values are not reset. OFF: The values are reset.
<input type="checkbox"/> C <input type="checkbox"/> U <input type="checkbox"/> F <input type="checkbox"/> E		
COLOR TEMP PRE	<u>3200K</u> 5600K	For selecting the AWB PRE color temperature.
<input type="checkbox"/> C <input type="checkbox"/> U <input type="checkbox"/> F <input type="checkbox"/> E		
AWB A	MEM VAR	For selecting the allocation of the WHITE BAL switch position and Ach. MEM: The switch position and Ach are allocated as memory values when AWB is executed. VAR: The color temperature of A can be set to vary using the COLOR TEMP A menu item.
<input type="checkbox"/> C <input type="checkbox"/> U <input type="checkbox"/> F <input type="checkbox"/> E		
COLOR TEMP A	<u>3200K</u> 5600K	For setting the color temperature when AWB A has been set to VAR.
<input type="checkbox"/> C <input type="checkbox"/> U <input type="checkbox"/> F <input type="checkbox"/> E		
AWB B	MEM ATW VAR	For selecting the allocation of the WHITE BAL switch position and Bch. MEM: The switch position and Bch are allocated as memory values when AWB is executed. ATW: The position and Bch are allocated as ATW start switch functions. VAR: The color temperature of B can be set to vary using the COLOR TEMP B menu item.
<input type="checkbox"/> C <input type="checkbox"/> U <input type="checkbox"/> F <input type="checkbox"/> E		
COLOR TEMP B	<u>3200K</u> 5600K	For setting the color temperature when AWB B has been set to VAR.
<input type="checkbox"/> C <input type="checkbox"/> U <input type="checkbox"/> F <input type="checkbox"/> E		
ATW SPEED	NORMAL SLOW FAST	For selecting the ATW control speed.
<input type="checkbox"/> C <input type="checkbox"/> U <input type="checkbox"/> F <input type="checkbox"/> E		

7-5-7 USER SW GAIN

Item/ Data storage	Variable range	Remarks
S.GAIN 30 dB	* ●	For selecting whether or not to enable a setting of 30 dB for SUPER GAIN. * : The 30 dB setting is enabled. ● : The 30 dB setting is disabled.
<input type="checkbox"/> C <input type="checkbox"/> U <input type="checkbox"/> F <input type="checkbox"/> E		
36 dB	* ●	For selecting whether or not to enable a setting of 36 dB for SUPER GAIN. * : The 36 dB setting is enabled. ● : The 36 dB setting is disabled.
<input type="checkbox"/> C <input type="checkbox"/> U <input type="checkbox"/> F <input type="checkbox"/> E		
42 dB	* ●	For selecting whether or not to enable a setting of 42 dB for SUPER GAIN. * : The 42 dB setting is enabled. ● : The 42 dB setting is disabled.
<input type="checkbox"/> C <input type="checkbox"/> U <input type="checkbox"/> F <input type="checkbox"/> E		
48 dB	* ●	For selecting whether or not to enable a setting of 48 dB for SUPER GAIN. * : The 48 dB setting is enabled. ● : The 48 dB setting is disabled.
<input type="checkbox"/> C <input type="checkbox"/> U <input type="checkbox"/> F <input type="checkbox"/> E		
DS.GAIN 6 dB ↑ (1/25)	* ●	For selecting whether or not to enable a setting increase of 6 dB for DS.GAIN. * : The 6 dB setting increase is enabled. ● : The 6 dB setting increase is disabled.
<input type="checkbox"/> C <input type="checkbox"/> U <input type="checkbox"/> F <input type="checkbox"/> E		
12 dB ↑ (1/12)	* ●	For selecting whether or not to enable a setting increase of 12 dB for DS.GAIN. * : The 12 dB setting increase is enabled. ● : The 12 dB setting increase is disabled.
<input type="checkbox"/> C <input type="checkbox"/> U <input type="checkbox"/> F <input type="checkbox"/> E		
20 dB ↑ (1/5)	* ●	For selecting whether or not to enable a setting increase of 20 dB for DS.GAIN. * : The 20 dB setting increase is enabled. ● : The 20 dB setting increase is disabled.
<input type="checkbox"/> C <input type="checkbox"/> U <input type="checkbox"/> F <input type="checkbox"/> E		

7

The underlining in the variable range column indicates the setting in the preset mode.

Chapter 7 Menu description tables

7-5-8 IRIS

Item/ Data storage	Variable range	Remarks
A.IRIS LEVEL	000 : 060 : 100	For setting the AUTO IRIS target value.
<u>C</u> <u>U</u> <u>F</u> <u>E</u>		
A.IRIS PEAK/AVE	000 : 040 : 100	For determining the ratio of the peak to the AUTO IRIS reference. The higher the ratio, the greater the response to the peak inside the iris detection window; the lower the ratio, the greater the response to the average value inside the iris detection window.
<u>C</u> <u>U</u> <u>F</u> <u>E</u>		
A.IRIS MODE	NORM1 NORM2 <u>CENTR</u>	For selecting the auto iris detection window. NORM1: Window from the screen center NORM2: Window from the bottom of the screen CENTR: Window in the shape of a spot at the screen center
<u>C</u> <u>U</u> <u>F</u> <u>E</u>		
S.IRIS LEVEL	000 : 080 : 100	For setting the SUPER IRIS target value.
<u>C</u> <u>U</u> <u>F</u> <u>E</u>		
IRIS GAIN	CAM <u>LENS</u>	For selecting the IRIS GAIN adjustment. <Note> With lenses equipped with an extender function (×2, ×0.8 etc.) sold before the DIGI POWER type manufactured by FUJINON, iris corrective control is performed with the extender function on at the LENS setting. As such, this unit's iris control will not function correctly when CAM has been selected as the setting for this item.
<u>C</u> <u>U</u> <u>F</u> <u>E</u>		
IRIS GAIN VALUE	01 : 08 : 20	For setting the IRIS GAIN adjustment value. The setting takes effect when IRIS GAIN has been set to CAM.
<u>C</u> <u>U</u> <u>F</u> <u>E</u>		

7-6 FILE

7-6-1 CARD READ/WRITE

Item/ Data storage	Variable range	Remarks
R.SELECT	1 : 8	For selecting the number of the file whose data is to be read.
<u>F</u>		
READ		For reading the data on the setup card.
<u>F</u>		
W.SELECT	1 : 8	For selecting the number of the file in which the data is to be written.
<u>F</u>		
WRITE		For writing the camera data onto the setup card.
<u>F</u>		
CARD CONFIG		For formatting the setup card.
<u>F</u>		
TITLE READ		For reading the titles given to the data on the setup card.
<u>F</u>		
TITLE1 - 8:		For setting a title consisting of not more than 8 characters.
<u>F</u>		

7-6-2 CARD R/W SELECT

Item/ Data storage	Variable range	Remarks
ID READ/WRITE	ON OFF	For selecting whether or not to handle the CAMERA ID during CARD READ/WRITE data operations.
<u>F</u>		
USER MENU SELECT R/W	ON OFF	For selecting whether or not to handle the FILE MENU settings during CARD READ/WRITE data operations.
<u>F</u>		
SYSTEM MENU R/W	ON OFF	For selecting whether or not to handle the SYSTEM SETTING items during CARD READ/WRITE data operations.
<u>F</u>		
PAINT MENU LEVEL R/W	ON OFF	For selecting whether or not to handle the PAINT MENU adjustment values during CARD READ/WRITE data operations.
<u>F</u>		
PAINT MENU SW (■) R/W	ON OFF	For selecting whether or not to handle the PAINT MENU settings during CARD READ/WRITE data operations.
<u>F</u>		
VF MENU R/W	ON OFF	For selecting whether or not to handle the VF MENU settings during CARD READ/WRITE data operations.
<u>F</u>		
OPERATION MENU R/W	ON OFF	For selecting whether or not to handle the OPERATION MENU settings during CARD READ/WRITE data operations.
<u>F</u>		
MAINTENANCE MENU R/W	ON OFF	For selecting whether or not to handle the MAINTENANCE MENU settings during CARD READ/WRITE data operations.
<u>F</u>		
VTR MENU R/W	ON OFF	For selecting whether or not to handle the VTR MENU settings during CARD READ/WRITE data operations.
<u>F</u>		

The underlining in the variable range column indicates the setting in the preset mode.

Chapter 7 Menu description tables

7-6-3 LENS FILE

Item/ Data storage	Variable range	Remarks
FILE NO. / / / / / / / /	<u>1</u> 8	For selecting the number of the lens file.
READ / / / / / / / /		For reading the data from the lens file.
WRITE / / / / / / / /		For writing the data in the lens file.
TITLE 1-8 / / / / / / / /	*****	For setting a title consisting of not more than 12 characters.

7-6-4 SCENE

Item/ Data storage	Variable range	Remarks
READ USER DATA / / / / / / / /		For reading the data from the memory's user area.
SCENE SEL / / / / / / / /	<u>1</u> 4	For selecting the scene file.
READ / / / / / / / /		For reading the data from the scene file.
WRITE / / / / / / / /		For writing the data in the scene file.
RESET / / / / / / / /		For returning the SCENE FILE values to the initial values.
TITLE 1-4 / / / / / / / /	*****	For creating a title for a scene file.

7-6-5 INITIALIZE

Item/ Data storage	Variable range	Remarks
READ FACTORY DATA / / / / / / / /		For resetting all MENU (USER MENU, MAIN MENU, OPTION MENU) values to factory settings.
WRITE USER DATA / / / / / / / /		For saving the user-specific menu data in the camera memory.
RESET LENS FILES / / / / / / / /		For returning all the lens file data (TITLE1 to TITLE8) created on the <LENS FILE> screen to the factory standard settings.

7-7 MAINTENANCE

7-7-1 SYSTEM CHECK

Item/ Data storage	Variable range	Remarks
COLOR CHECK / / / / / / / /	ON <u>OFF</u>	For selecting ON or OFF for checking whether or not the camera recorder is functioning correctly. The Y and RGB values at the center are displayed in the viewfinder, and whether the signals of each system are being processed correctly from the optical system to the digital system is indicated.

7-7-2 DIAGNOSTIC

Item/ Data storage	Variable range	Remarks
CAMSOFT (IN) / / / / / / / /		For displaying the version of the software used for the flash memory incorporated in the microcomputer.
CAMSOFT (OUT) / / / / / / / /		For displaying the version of the software used for the externally connected flash memory.
CAM TABLE / / / / / / / /		For displaying the version of the tables.
FONT ROM / / / / / / / /		For displaying the version of the font used for the characters.
FPGA (CHARX) / / / / / / / /		For displaying the version of the program software used for the characters.
FPGA (FMX) / / / / / / / /		For displaying the version of the program software used for the memory.
FPGA (TGA) / / / / / / / /		For displaying the version of the program software used for the CCD drive.

7-7-3 LENS ADJ

Item/ Data storage	Variable range	Remarks
F2.8 ADJ / / / / / / / /	ON <u>OFF</u>	The iris is set to f/2.8 only when ON is set for this item.
F16 ADJ / / / / / / / /	ON <u>OFF</u>	The iris is set to f/16 only when ON is set for this item.

The underlining in the variable range column indicates the setting in the preset mode.

Chapter 7 Menu description tables

7-7-4 BLACK SHADING

Item/ Data storage	Variable range	Remarks
CORRECT C U F E	ON OFF	For selecting ON or OFF for the digital black shading compensation.
DETECTION (DIG)	—	For executing the digital black shading compensation.

7-7-5 WHITE SHADING

Item/ Data storage	Variable range	Remarks
CORRECT C U F E	ON OFF	For selecting ON or OFF for the white shading compensation.
DETECTION (V SAW)	—	For executing the white shading compensation.

7-8 VTR MENU

7-8-1 VTR FUNCTION

Item/ Data storage	Variable range	Remarks
HUMID OPE C U F E	ON OFF	For selecting whether or not to continue operation when HUMID alarm state has occurred.
REC START C U F E	ALL NORMAL	For selecting how recording start is to be accepted.
PAUSE TIMER C U F E	10min 20min 30min 60min	For selecting the time during which REC/PAUSE is to continue.
ECU REC CHK SW C U F E	R.REVIEW RETAKE	For setting the unit's operation to be performed using the REC check button on the ECU. R.REVIEW: The rec-review operation is performed. RETAKE: The retake operation is performed, after which playback is initiated automatically.

The underlining in the variable range column indicates the setting in the preset mode.

Chapter 7 Menu description tables

7-8-2 BATTERY/TAPE

Item/ Data storage	Variable range	Remarks
BATTERY SELECT	PRO14 TRIM14 HYTRON50 HYTRON100 HYTRON120 DIONIC90 DIONIC160 HP-90L BP-H120 NP-L50 ENDURA50 ENDURA80 BP-L60/90 NiCd14 NiCd13 NiCd12 TYPE A TYPE B	For selecting the type of battery to be used. The remaining charge is detected in accordance with the battery which has been selected. The variable range is changed by the item settings selected on the "7-8-3 BATTERY SETTING1" and "7-8-4 BATTERY SETTING2" menus. Note that the initial value for TYPE A corresponds to the PROFORMER and for initial value for TYPE B to the HYTRON100, both of which are manufactured by Anton Bauer.
<input type="checkbox"/> C <input type="checkbox"/> U <input type="checkbox"/> F <input type="checkbox"/>		
EXT DC IN SELECT	AC ADPT PRO14 TRIM14 HYTRON50 HYTRON100 HYTRON120 DIONIC90 DIONIC160 HP-90L BP-H120 NP-L50 ENDURA50 ENDURA80 BP-L60/90 NiCd14 NiCd13 NiCd12 TYPE A TYPE B	The variable range is changed by the item settings selected on the "7-8-3 BATTERY SETTING1" and "7-8-4 BATTERY SETTING2" menus.
<input type="checkbox"/> C <input type="checkbox"/> U <input type="checkbox"/> F <input type="checkbox"/>		
BATT NEAR END ALARM	ON OFF	For setting whether or not to output the warning tone when the battery charge is nearly depleted.
<input type="checkbox"/> C <input type="checkbox"/> U <input type="checkbox"/> F <input type="checkbox"/>		
BATT NEAR END CANCEL	ON OFF	When this item is set to ON, the warning tone and the warning display which are being output can be canceled by pressing the MODE switch when the battery charge is nearly depleted.
<input type="checkbox"/> C <input type="checkbox"/> U <input type="checkbox"/> F <input type="checkbox"/>		
BATT END ALARM	ON OFF	For setting whether or not to output the warning tone when the battery charge is depleted.
<input type="checkbox"/> C <input type="checkbox"/> U <input type="checkbox"/> F <input type="checkbox"/>		
BATT REMAIN FULL	100% 70%	For setting when the remaining charge display bar on the LCD is to be displayed when a digital battery is used. 70%: A full charge is indicated with a 70% display 100%: A full charge is indicated with a 100% display.
<input type="checkbox"/> C <input type="checkbox"/> U <input type="checkbox"/> F <input type="checkbox"/>		
TAPE NEAR END ALARM	ON OFF	For setting whether or not to output the warning tone when the tape is nearly at its end.
<input type="checkbox"/> C <input type="checkbox"/> U <input type="checkbox"/> F <input type="checkbox"/>		
TAPE NEAR END TIME	3min 2min	For setting the remaining tape time at which to sound the warning that the tape has only the designated amount of time (2min. or 3min.) remaining.
<input type="checkbox"/> C <input type="checkbox"/> U <input type="checkbox"/> F <input type="checkbox"/>		
TAPE END ALARM	ON OFF	For setting whether or not to output the warning tone when the tape reaches the end.
<input type="checkbox"/> C <input type="checkbox"/> U <input type="checkbox"/> F <input type="checkbox"/>		
TAPE REMAIN/■	5min/■ 3min/■	For setting the time of each segment (■) that makes up the remaining time display bar on the LCD. 5min: Each segment denotes a remaining time of 5 minutes. 3min: Each segment denotes a remaining time of 3 minutes.
<input type="checkbox"/> C <input type="checkbox"/> U <input type="checkbox"/> F <input type="checkbox"/>		

7-8-3 BATTERY SETTING1

Item/ Data storage	Variable range	Remarks
PRO14	* /	For enabling or disabling the selection made for the BATTERY SELECT item. *: The selection is enabled. /: The selection is disabled.
	AUTO MANUAL	For selecting how the voltage at which the battery charge is considered nearly depleted is to be set. AUTO: The voltage is set automatically. MANUAL: The voltage is set manually.
	11.0 13.8	For selecting the voltage at which the battery charge is to be considered nearly depleted in 0.1 V steps when MANUAL has been selected as the setting for the menu item above.
<input type="checkbox"/> C <input type="checkbox"/> U <input type="checkbox"/> F <input type="checkbox"/>	15.0	
TRIM14	* /	For enabling or disabling the selection made for the BATTERY SELECT item. *: The selection is enabled. /: The selection is disabled.
	AUTO MANUAL	For selecting how the voltage at which the battery charge is considered nearly depleted is to be set. AUTO: The voltage is set automatically. MANUAL: The voltage is set manually.
	11.0 13.6	For selecting the voltage at which the battery charge is to be considered nearly depleted in 0.1 V steps when MANUAL has been selected as the setting for the menu item above.
<input type="checkbox"/> C <input type="checkbox"/> U <input type="checkbox"/> F <input type="checkbox"/>	15.0	
HYTRON50	* /	For enabling or disabling the selection made for the BATTERY SELECT item. *: The selection is enabled. /: The selection is disabled.
	AUTO MANUAL	For selecting how the voltage at which the battery charge is considered nearly depleted is to be set. AUTO: The voltage is set automatically. MANUAL: The voltage is set manually.
	11.0 13.8	For selecting the voltage at which the battery charge is to be considered nearly depleted in 0.1 V steps when MANUAL has been selected as the setting for the menu item above.
<input type="checkbox"/> C <input type="checkbox"/> U <input type="checkbox"/> F <input type="checkbox"/>	15.0	
HYTRON100	* /	For enabling or disabling the selection made for the BATTERY SELECT item. *: The selection is enabled. /: The selection is disabled.
	AUTO MANUAL	For selecting how the voltage at which the battery charge is considered nearly depleted is to be set. AUTO: The voltage is set automatically. MANUAL: The voltage is set manually.
	11.0 13.1	For selecting the voltage at which the battery charge is to be considered nearly depleted in 0.1 V steps when MANUAL has been selected as the setting for the menu item above.
<input type="checkbox"/> C <input type="checkbox"/> U <input type="checkbox"/> F <input type="checkbox"/>	15.0	

Chapter 7 Menu description tables

Item/ Data storage	Variable range	Remarks
HYTRON120	* /	For enabling or disabling the selection made for the BATTERY SELECT item. * : The selection is enabled. / : The selection is disabled.
	AUTO MANUAL	For selecting how the voltage at which the battery charge is considered nearly depleted is to be set. AUTO: The voltage is set automatically. MANUAL: The voltage is set manually.
	11.0 13.1 15.0	For selecting the voltage at which the battery charge is to be considered nearly depleted in 0.1 V steps when MANUAL has been selected as the setting for the menu item above.
<input type="checkbox"/> C <input type="checkbox"/> U <input type="checkbox"/> F <input type="checkbox"/>		
DIONIC90	* /	For enabling or disabling the selection made for the BATTERY SELECT item. * : The selection is enabled. / : The selection is disabled.
	AUTO MANUAL	For selecting how the voltage at which the battery charge is considered nearly depleted is to be set. AUTO: The voltage is set automatically. MANUAL: The voltage is set manually.
	11.0 13.6 15.0	For selecting the voltage at which the battery charge is to be considered nearly depleted in 0.1 V steps when MANUAL has been selected as the setting for the menu item above.
<input type="checkbox"/> C <input type="checkbox"/> U <input type="checkbox"/> F <input type="checkbox"/>		
DIONIC160	* /	For enabling or disabling the selection made for the BATTERY SELECT item. * : The selection is enabled. / : The selection is disabled.
	AUTO MANUAL	For selecting how the voltage at which the battery charge is considered nearly depleted is to be set. AUTO: The voltage is set automatically. MANUAL: The voltage is set manually.
	11.0 13.3 15.0	For selecting the voltage at which the battery charge is to be considered nearly depleted in 0.1 V steps when MANUAL has been selected as the setting for the menu item above.
<input type="checkbox"/> C <input type="checkbox"/> U <input type="checkbox"/> F <input type="checkbox"/>		
HP-90L *1	* /	For enabling or disabling the selection made for the BATTERY SELECT item. * : The selection is enabled. / : The selection is disabled.
	AUTO MANUAL	For selecting how the voltage at which the battery charge is considered nearly depleted is to be set. AUTO: The voltage is set automatically. MANUAL: The voltage is set manually.
	11.0 12.4 15.0	For selecting the voltage at which the battery charge is to be considered nearly depleted in 0.1 V steps when MANUAL has been selected as the setting for the menu item above.
<input type="checkbox"/> C <input type="checkbox"/> U <input type="checkbox"/> F <input type="checkbox"/>		

Item/ Data storage	Variable range	Remarks
BP-H120	* /	For enabling or disabling the selection made for the BATTERY SELECT item. * : The selection is enabled. / : The selection is disabled.
	AUTO MANUAL	For selecting how the voltage at which the battery charge is considered nearly depleted is to be set. AUTO: The voltage is set automatically. MANUAL: The voltage is set manually.
	11.0 11.7 15.0	For selecting the voltage at which the battery charge is to be considered nearly depleted in 0.1 V steps when MANUAL has been selected as the setting for the menu item above.
<input type="checkbox"/> C <input type="checkbox"/> U <input type="checkbox"/> F <input type="checkbox"/>		
NP-L50	* /	For enabling or disabling the selection made for the BATTERY SELECT item. * : The selection is enabled. / : The selection is disabled.
	AUTO MANUAL	For selecting how the voltage at which the battery charge is considered nearly depleted is to be set. AUTO: The voltage is set automatically. MANUAL: The voltage is set manually.
	11.0 13.1 15.0	For selecting the voltage at which the battery charge is to be considered nearly depleted in 0.1 V steps when MANUAL has been selected as the setting for the menu item above.
<input type="checkbox"/> C <input type="checkbox"/> U <input type="checkbox"/> F <input type="checkbox"/>		
ENDURA50	* /	For enabling or disabling the selection made for the BATTERY SELECT item. * : The selection is enabled. / : The selection is disabled.
	AUTO MANUAL	For selecting how the voltage at which the battery charge is considered nearly depleted is to be set. AUTO: The voltage is set automatically. MANUAL: The voltage is set manually.
	11.0 12.9 15.0	For selecting the voltage at which the battery charge is to be considered nearly depleted in 0.1 V steps when MANUAL has been selected as the setting for the menu item above.
<input type="checkbox"/> C <input type="checkbox"/> U <input type="checkbox"/> F <input type="checkbox"/>		

*1: Select this item for the PHD-90L manufactured by PACO.

The underlining in the variable range column indicates the setting in the preset mode.

Chapter 7 Menu description tables

7-8-4 BATTERY SETTING2

Item/ Data storage	Variable range	Remarks
ENDURA80	* /	For enabling or disabling the selection made for the BATTERY SELECT item. * : The selection is enabled. / : The selection is disabled.
	AUTO MANUAL	For selecting how the voltage at which the battery charge is considered nearly depleted is to be set. AUTO: The voltage is set automatically. MANUAL: The voltage is set manually.
	11.0 : <u>13.6</u> :	For selecting the voltage at which the battery charge is to be considered nearly depleted in 0.1 V steps when MANUAL has been selected as the setting for the menu item above.
	<input type="checkbox"/> C <input type="checkbox"/> U <input type="checkbox"/> F <input type="checkbox"/>	15.0
BP-L60/90	* /	For enabling or disabling the selection made for the BATTERY SELECT item. * : The selection is enabled. / : The selection is disabled.
	AUTO MANUAL	For selecting how the voltage at which the battery charge is considered nearly depleted is to be set. AUTO: The voltage is set automatically. MANUAL: The voltage is set manually.
	11.0 : <u>15.0</u> :	For selecting the voltage at which the battery charge is to be considered nearly depleted in 0.1 V steps when MANUAL has been selected as the setting for the menu item above.
	<input type="checkbox"/> C <input type="checkbox"/> U <input type="checkbox"/> F <input type="checkbox"/>	

<Note>

In the case of a digital battery (PRO14, TRIM14, HYTRON50, HYTRON100, HYTRON120, DIONIC90, DIONIC160 or NP-L50), the remaining battery charge displayed in the viewfinder appears as a percentage.

What is displayed to warn the user that the end of the remaining battery charge is approaching is determined by the setting on the <BATTERY SETTING> screen regardless of the percentage display.

Item/ Data storage	Variable range	Remarks
NiCd14	* /	For enabling or disabling the selection made for the BATTERY SELECT item. * : The selection is enabled. / : The selection is disabled.
	NEAR END	11.0 : <u>13.6</u> : 15.0
	END	11.0 : <u>13.2</u> : 15.0
	<input type="checkbox"/> C <input type="checkbox"/> U <input type="checkbox"/> F <input type="checkbox"/>	
NiCd13	* /	For enabling or disabling the selection made for the BATTERY SELECT item. * : The selection is enabled. / : The selection is disabled.
	NEAR END	11.0 : <u>12.7</u> : 15.0
	END	11.0 : <u>12.2</u> : 15.0
	<input type="checkbox"/> C <input type="checkbox"/> U <input type="checkbox"/> F <input type="checkbox"/>	
NiCd12	* /	For enabling or disabling the selection made for the BATTERY SELECT item. * : The selection is enabled. / : The selection is disabled.
	NEAR END	11.0 : <u>11.5</u> : 15.0
	END	11.0 : <u>11.2</u> : 15.0
	<input type="checkbox"/> C <input type="checkbox"/> U <input type="checkbox"/> F <input type="checkbox"/>	

7

The underlining in the variable range column indicates the setting in the preset mode.

Chapter 7 Menu description tables

7-8-5 MIC/AUDIO1

Item/ Data storage	Variable range	Remarks
TYPE A	* /	For enabling or disabling the selection made for the BATTERY SELECT item. * : The selection is enabled. / : The selection is disabled.
FULL	12.0 15.0 17.0	For selecting in 0.1 V steps the voltage at which FULL is to be displayed.
NEAR END	11.0 13.5 15.0	For selecting in 0.1 V steps the voltage at which the battery charge is to be considered nearly depleted.
END	11.0 11.9 15.0	For selecting in 0.1 V steps the voltage at which the battery charge is to be considered depleted.
<input type="checkbox"/> C <input type="checkbox"/> U <input type="checkbox"/> F <input type="checkbox"/>		
TYPE B	* /	For enabling or disabling the selection made for the BATTERY SELECT item. * : The selection is enabled. / : The selection is disabled.
FULL	12.0 15.5 17.0	For selecting in 0.1 V steps the voltage at which FULL is to be displayed.
NEAR END	11.0 13.1 15.0	For selecting in 0.1 V steps the voltage at which the battery charge is to be considered nearly depleted.
END	11.0 12.6 15.0	For selecting in 0.1 V steps the voltage at which the battery charge is to be considered depleted.
<input type="checkbox"/> C <input type="checkbox"/> U <input type="checkbox"/> F <input type="checkbox"/>		

Item/ Data storage	Variable range	Remarks
FRONT VR CH1	FRONT W.L. REAR ALL OFF	For setting whether or not to make the audio control operational for the input system selected for CH1.
<input type="checkbox"/> C <input type="checkbox"/> U <input type="checkbox"/> F <input type="checkbox"/>		
FRONT VR CH2	FRONT W.L. REAR ALL OFF	For setting whether or not to make the audio control operational for the input system selected for CH2.
<input type="checkbox"/> C <input type="checkbox"/> U <input type="checkbox"/> F <input type="checkbox"/>		
MIC LOWCUT CH1	FRONT REAR W.L. OFF	For selecting the microphone low-cut filter for CH1.
<input type="checkbox"/> C <input type="checkbox"/> U <input type="checkbox"/> F <input type="checkbox"/>		
MIC LOWCUT CH2	FRONT REAR W.L. OFF	For selecting the microphone low-cut filter for CH2.
<input type="checkbox"/> C <input type="checkbox"/> U <input type="checkbox"/> F <input type="checkbox"/>		
LIMITER CH1	ON OFF	For selecting the limiter for CH1.
<input type="checkbox"/> C <input type="checkbox"/> U <input type="checkbox"/> F <input type="checkbox"/>		
LIMITER CH2	ON OFF	For selecting the limiter for CH2.
<input type="checkbox"/> C <input type="checkbox"/> U <input type="checkbox"/> F <input type="checkbox"/>		
CUE REC SELECT	CH1 CH2 CH1+CH2	For selecting the signals to be recorded for the CUE channel.
<input type="checkbox"/> C <input type="checkbox"/> U <input type="checkbox"/> F <input type="checkbox"/>		
TEST TONE	NORMAL ALWAYS OFF CHSEL	For selecting the test signal. NORMAL: The test tone signal is output to all the channels when the CAM/BAR switch has been set to BAR and the CH1 AUDIO IN switch has been set to FRONT. ALWAYS: The test tone signal is always output to all the channels when the CAM/BAR switch has been set to BAR. OFF: The test tone signal is not output. CHSEL: The test tone signal is output to the channels for which the CH1 or CH2 AUDIO IN switch has been set to FRONT when the CAM/BAR switch is set to BAR. It is not output to CH3 or CH4.
<input type="checkbox"/> C <input type="checkbox"/> U <input type="checkbox"/> F <input type="checkbox"/>		

Chapter 7 Menu description tables

7-8-6 MIC/AUDIO2

Item/ Data storage	Variable range	Remarks
FRONT MIC POWER / C U F /	ON OFF	For selecting the phantom power supply for the front microphone.
REAR MIC POWER / C U F /	ON OFF	For selecting the phantom power supply for the rear microphone.
AUDIO OUT / C U F /	ON OFF	For setting the audio output circuit. OFF: The power to the output circuit is shut down, and the signals of the circuit are not output. ON: The signals of the audio output circuit are output.
MONITOR SELECT SDC905 / C U F /	STEREO MIX	For selecting the format of the signals to be output to the monitor.
FRONT MIC LEVEL / C U F /	-40dB -50dB	For selecting the input level of the front microphone.
REAR MIC CH1 LVL / C U F /	-50dB -60dB	For selecting the input level of the rear microphone.
REAR MIC CH2 LVL / C U F /	-50dB -60dB	For selecting the input level of the rear microphone.
REAR LINE IN LVL / C U F /	0dB +4dB	For selecting the rear line input level.
AUDIO OUT LVL / C U F /	0dB +4dB	For selecting the rear audio output level.
HEADROOM / C U F /	18dB 20dB	For setting the headroom (reference level).
WIRELESS WARN / C U F /	ON OFF	For selecting whether or not to output warnings when the reception of the wireless receiver is poor.

7-8-7 TC/UB

Item/ Data storage	Variable range	Remarks
UB MODE / C U F /	USER TIME DATE EXT TCG FRM RATE REGEN	For selecting the UB mode. USER: Selects the UB value set in the LCD section. TIME: Selects the local time (hour, minute, second). DATE: Selects the local date and time (last 2 digits of year, month, date, hour) EXT: When CAM or VIDEO is selected as the REC SIGNAL menu item setting on the <SYSTEM MODE> screen, the user bits of the signal supplied to the TC IN connector are used as the reference. When 1394 is selected, user bits of the signal supplied to the DVCPRO connector are used as reference. If the user bits cannot be read, the user bits which are set in the unit are retained. TCG: Inputs the TCG value unchanged. FRM RATE: Selects the same camera shooting data (frame rate, etc.) as the VAUX UB (VITC UB). REGEN: Reads the value recorded on the tape and then continues to record from that value.
VITC UB MODE / C U F /	USER/EXT TIME DATE TCG FRM RATE REGEN	For selecting the VAUX TC (VITC) UB mode. USER/EXT: When EXT is selected as the UB MODE setting, the value concerned applies; with any other setting, the USER value set by UB is recorded. TIME: The local time (in hours, minutes and seconds) is selected. DATE: The local date (last 2 digits of AD year, month, day and hours) is selected. TCG: The TCG value is used as is for UB. FRM RATE: The same shooting information (frame rate, etc.) of the camera as for VAUX UB (VITC UB) is selected. REGEN: The value recorded on the tape is read and recorded continuously.

7

The underlining in the variable range column indicates the setting in the preset mode.

Chapter 7 Menu description tables

7-8-9 VTR DIAG

Item/ Data storage	Variable range	Remarks
TCG SET HOLD C U F	ON <u>OFF</u>	For selecting ON or OFF for the function that without fail uses what was previously set as the TCG value for recording when the TCG value had been set before the power was turned off and recording was then performed after the power was turned back on again.
FIRST REC TC C U F	REGEN <u>PRESET</u>	For selecting whether or not to regenerate the time code as the value on the tape during the first recording after the power was turned on, the cassette was inserted or a playback or search operation was performed.
P.OFF LCD DISPLAY C U F	ON <u>OFF</u>	For selecting whether or not to set the LCD's time code and display its count while the power is off. ON: The time code can be set and displayed even while the power is off. OFF: While the power is off, the power to the LCD section is turned off, and the time code can be neither set nor displayed.
TC OUT C U F	TCG <u>TCG/TCR</u>	For selecting the TC OUT output. TCG: The time code generator value is always output. TCG/TCR: The time code generator value is output with the E-E setting and the time code reader value is output with the playback mode.

7-8-8 UMID SET/INFO

Item/ Data storage	Variable range	Remarks
COUNTRY C U F	<u>NO-INFO</u>	For inputting the name of the user's country. "NO-INFO" is displayed until this is input.
ORGANIZATION C U F	<u>NO-INFO</u>	For inputting the name of the user's organization or company. "NO-INFO" is displayed until this is input.
USER C U F	<u>NO-INFO</u>	For inputting the user's name. "NO-INFO" is displayed until this is input.
DEVICE NODE / / / / /		For displaying the ID number of the product.

Item/ Data storage	Variable range	Remarks
OPERATION / / / / /		For displaying the total time during which the power has been on.
DRUM RUNNING / / / / /		For displaying the total time during which the drum has rotated.
THREADING / / / / /		For displaying the total number of times cassettes have been loaded.
DRUM RUNNING R / / / / /		For displaying the total time during which the drum has rotated after resetting.
THREADING R / / / / /		For displaying the total number of times cassettes have been loaded after resetting.
VTR SYSCON / / / / /		For displaying the software version of the VTR SYSCON microcomputer.
SERVO / / / / /		For displaying the software version of the SERVO microcomputer.
FRONT / / / / /		For displaying the software version of the LCD microcomputer.
FPGA (PRE RECX) SDC905 FPGA (VMX) SDC615 / / / / /		For displaying the version of the software used for pre-recording.
FPGA (PRE PROX) / / / / /		For displaying the compressed image software version.
1394 FPGA / / / / /		For displaying the 1394 control software version.

The underlining in the variable range column indicates the setting in the preset mode.

Chapter 7 Menu description tables

7-9 OPTION MENU

7-9-1 OPTION

Item/ Data storage	Variable range	Remarks
ENG SECURITY / C / / / /	<u>ON</u> OFF	For selecting whether or not to place a restriction on the opening and closing of the MENU screen. ON: The MENU screen can no longer be opened. To release this restriction, consult your nearest service center. OFF: No restriction is placed on the opening and closing of the MENU screen.
ID MIX INH / C / / / /	<u>ON</u> OFF	For selecting whether or not to turn off the function that mixes the ID with the camera image. ON: Mixing is turned off. The ID is not mixed with the camera image. OFF: Mixing is enabled. The CAMERA ID settings for VF INDICATOR1 are used.
1394 CONFIG / C / / / /	<u>DFLT</u> 1 : : 255	Menu item for expansion purposes. Normally, DFLT is used.
1394 GAP COUNT / C / / / /	0 : <u>40</u> : 63	For setting the communication response time of the DVCPRO connector.

The underlining in the variable range column indicates the setting in the preset mode.

Chapter 8 Specifications

[GENERAL]

Power supply:	DC 12 V (11.0 - 17.0 V)
Power consumption:	24 W SDC615
	25 W SDC905

 indicates safety information.

Ambient operating temperature:

0°C to +40°C

Storage temperature:

-20°C to +60°C

Ambient operating humidity:

Within 10% to 85% (relative humidity)

Continuous operation time:

Approx. 120 min. (using the Hytron50 made by Anton Bauer)

Dimensions (W×H×D):

129×204×313 mm (excluding handle)

Weight:

Approx. 4.1 kg (main unit only)

[CAMERA UNIT]

Pickup devices:

2/3-inch CCD ×3

Filter:

- 1: 3200 K (CLEAR)
- 2: 5600 K+1/8ND
- 3: 5600 K
- 4: 5600 K+1/64ND

Quantizing:

12 bits/18 MHz

Digital signal processing:

36 MHz

Horizontal drive frequency:

18 MHz

Programmable gain values:

Any 3 positions (L, M, H) can be set from among -3, 0, 3, 6, 9, 12, 15, 18, 21, 24, 27 and 30 dB

S.GAIN function:

30, 36, 42 or 48 dB selectable

DS.GAIN function:

+6, +12 or +20 dB gain increase selectable

Shutter speeds:

1/60, 1/120, 1/250, 1/500, 1/1000 and 1/2000

Synchro scan shutter:

1/50.4 to 1/248.0

Lens mount:

2/3-inch Bayonet type

Optical system:

F1.4 prism system

Sensitivity:

F13 (2000 lux, 89.9% reflection)

Minimum subject brightness:

0.01 lux (at F1.4, 48 dB + gain increase of 20 dB)

Video signal-to-noise ratio:

62 dB (typical)

Horizontal resolution:

750 lines (center, typical)

Vertical resolution:

450 or 500 lines (SUPER V mode)

Registration:

Less than 0.05% (entire area, excluding lens distortion)

[VTR UNIT]

Video System

Analog component output

Band:

DVCPRO:

Y: 25 Hz to 5.75 MHz +1.0/-3.0 dB

DVCPRO 50 **SDC905**:

Y: 25 Hz to 5.75 MHz +1.0/-3.0 dB

PB/Pr: 25 Hz to 2.75 MHz +1.0/-3.0 dB

Signal-to-noise ratio:

55 dB

Audio System

Sampling frequency:

48 kHz (synchronized with video)

Quantizing:

16 bits

Frequency response:

20 Hz to 20 kHz ±1.0 dB (reference level)

Dynamic range:

Better than 85 dB (at 1 kHz, AWTD)

Distortion:

Less than 0.1% (at 1 kHz, reference level)

Wow and flutter:

Below measurable limits

Head room:

18 dB

Chapter 8 Specifications

Tape Transport System

Tape speed:

DVCPRO:

33.854 mm/sec

DVCPRO 50 **SDC905**:

67.708 mm/sec

Recording time:

DVCPRO:

66 minutes (when AJ-P66MP is used)

DVCPRO 50 **SDC905**:

33 minutes (when AJ-5P33MP is used)

Fast forwarding time:

Approx. 1 min. 30 sec. (when AJ-P66MP is used)

Approx. 1 min. 30 sec. (when AJ-5P33MP is used) **SDC905**

Rewinding time:

Approx. 1 min. 30 sec. (when AJ-P66MP is used)

Approx. 1 min. 30 sec. (when AJ-5P33MP is used) **SDC905**

[CONNECTOR SECTION]

Audio Input Connectors

AUDIO IN CH1/CH2 (XLR ×2, 3 pins):

LINE/MIC/MIC + 48 V switching type

LINE: 0 dBu (0 or +4 dBu, selected on menu)

MIC: -60 dBu (-60 or -50 dBu, selected on menu)

MIC + 48 V:

Phantom power supply + 48 V supported,

-60 dBu (-60 or -50 dBu, selected on menu)

MIC IN (XLR, 3 pins):

Phantom + 48 V:

ON or OFF, 3 k Ω , balanced, -50 or -40 dBu, selected on menu

WIRELESS IN (25 pins):

D-SUB, -40 dBu

Audio Output Connectors

AUDIO OUT CH1/CH2 (XLR, 5 pins):

+0 dBu (0 or +4 dBu, selected on menu, balanced low impedance)

Earphone (stereo mini jacks ×2)

Video Input Connector

GEN LOCK IN (BNC):

1.0 Vp-p, 75 Ω

Video Output Connector

MON OUT (BNC):

1.0 Vp-p, 75 Ω

VIDEO OUT (BNC):

1.0 Vp-p, 75 Ω

Time Code Input Connector

TC IN (BNC):

0.5 to 8 Vp-p, high impedance

Time Code Output Connector

TC OUT (BNC):

2.0 Vp-p, low impedance

Other Connectors

DC IN (XLR, 4 pins, male):

DC 12 V (DC 11 to 17 V)

DC OUT (4 pins):

DC 12 V (DC 11 to 17 V), max. 1 A

PHONE OUT (stereo mini jacks ×2)

LENS (multi 12 pins)

EVF (multi 20 pins)

GPS (6 pins, connector used for AJ-GPS900G)

ECU (6 pins, connector used for AJ-EC3E)

DVCPRO (6 pins):

Compliant with IEEE 1394

[ACCESSORIES]

Shoulder strap

Control knob

Screw (M2×6 mm) (XYNZ + J6FZ) ×1

Panasonic Broadcast Europe
Panasonic Marketing Europe GmbH

Hagenauer Str. 43, 65203 Wiesbaden-Biebrich Deutschland Tel: 49-611-235-481



Printed in Japan
VQT0M92-1

F0604W1074-F 