

# Panasonic Broadcast Mechanical Parts List

Model No. : AG-HVX200AP/AN, AG-HVX201AE, AG-HVX202AEN

---

Note:

1. \*Be sure to make your orders of replacement parts according to this list.
2. Unless otherwise specified, all resistors are in OHMS, K=1,000 OHMS, all capacitors are in MICROFARADS ( $\mu\text{F}$ ), P= $\mu\mu\text{F}$ .
3. The P.C. Board unit marked with "■" shown below the main assembled parts.
4. The parts marked with (E) on the exploded view show the electric parts.
5. IMPORTANT SAFETY NOTICE  
Components identified with the mark  $\Delta$  have the special characteristics for safety. When replacing any of these components, use only the same type.
6. The marking (RTL) indicates the retention time is limited for this item.  
After the discontinuation of this assembly in production, it will no longer be available.
7. "M" in Remark column indicates needed in the periodical maintenance.

## CONTENTS

FRAME & CASING PARTS ASSEMBLY (1).....	MPL-1
FRAME & CASING PARTS ASSEMBLY (2).....	MPL-3
HANDLE EVF PARTS ASSEMBLY .....	MPL-5
LCD PARTS ASSEMBLY .....	MPL-7
PACKING PARTS .....	MPL-9

# FRAME & CASING PARTS ASSEMBLY (1)

Components identified with the mark  have the special characteristics for safety. When replacing any of these components, use only the same type.

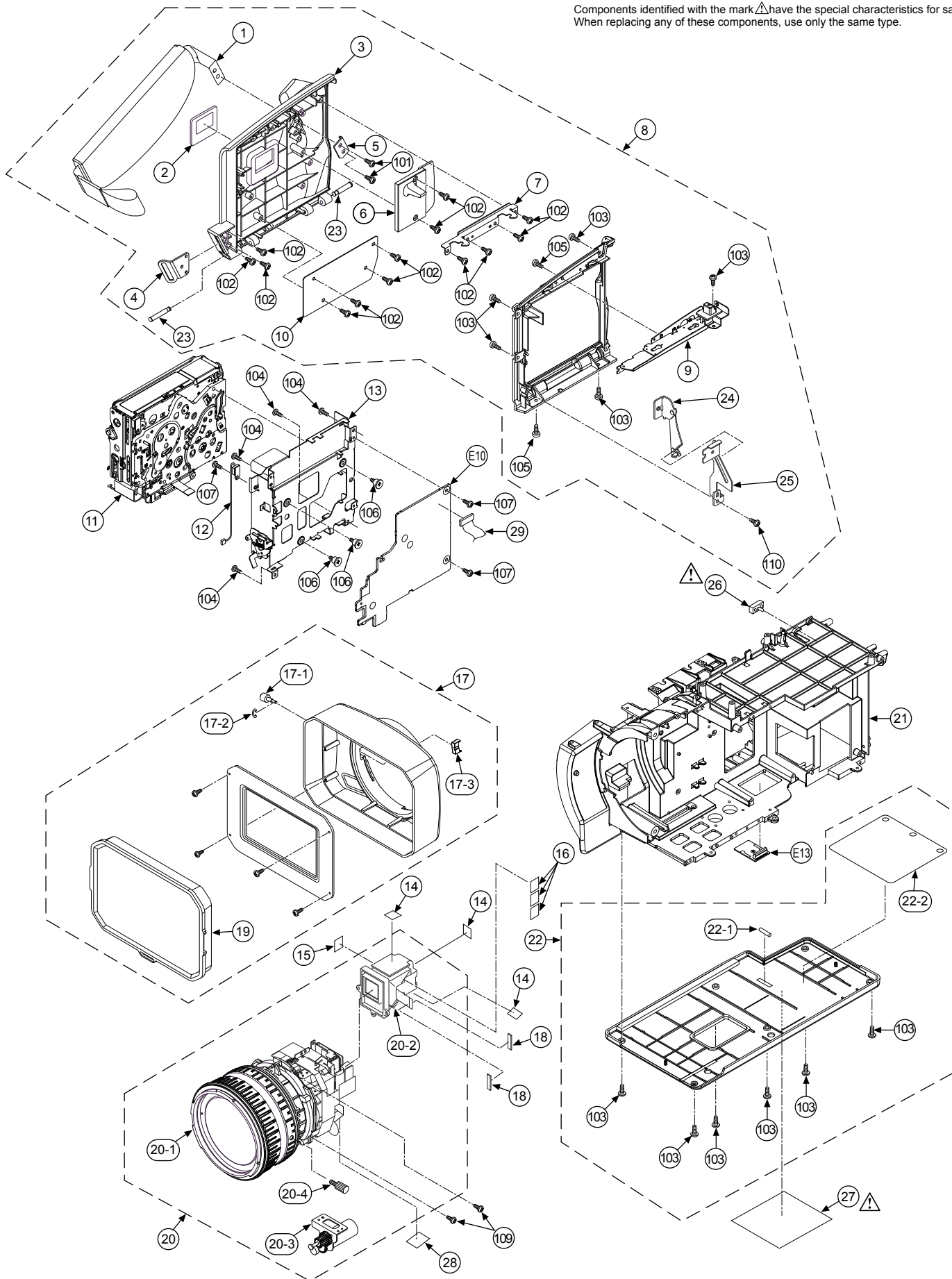



# FRAME & CASING PARTS ASSEMBLY (2)

Components identified with the mark  $\triangle$  have the special characteristics for safety. When replacing any of these components, use only the same type.

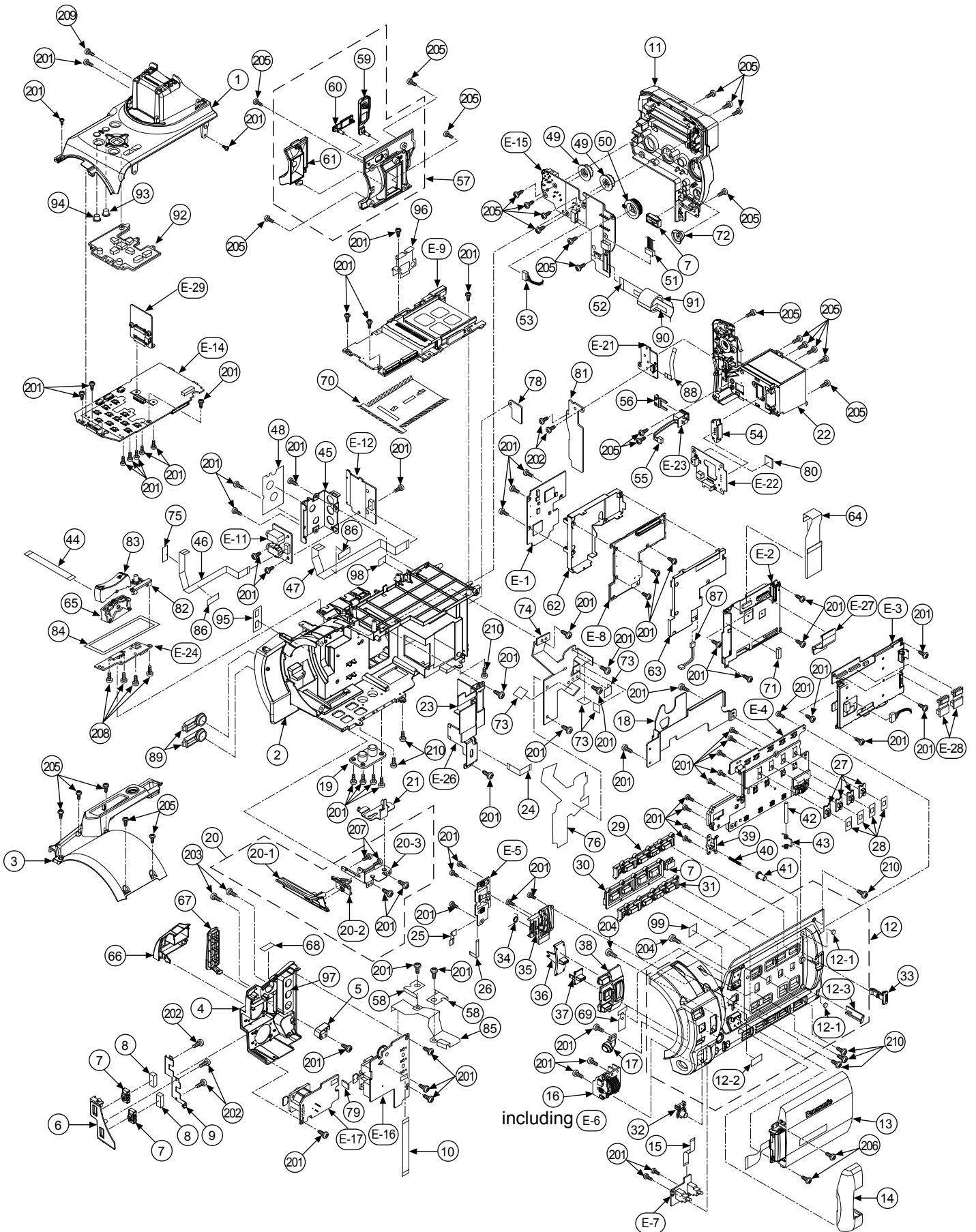

## FRAME & CASING PARTS ASSEMBLY(2)

Ref.No.	Part No.	Part Name & Description	Pcs	Remarks	Ref.No.	Part No.	Part Name & Description	Pcs	Remarks
1	VGM2154	TOP PANEL U	1		71	VMG1727	LENS CUSHION	1	
2	VKM6880	MAIN FRAME	1		72	VGU9219	CAMERA/VCR BUTTON	1	
3	VYK1U94	ZOOM SW CASE U	1		73	VSC5833	CERAMIC SEAT HEAT RADIATION	4	
4	VGM2280	JACK FRAME	1		74	VSC5824	CDS HEAT SINK	1	
5	VKW3303	AWB SENSOR WINDOW	1		75	VMZ3465	CD CON CUSHION	1	
6	VGG8838	AUDIO SW COVER	1		76	VSC5845	CDS RADIATION SHEET	1	
7	VGU0A01	MODE SW KNOB	4		78	VYF3081	EVR COVER U	1	
8	VMT1761	FRONT MIC SW SHEET	2		79	VMT1766	EVF FPC CUSHION	1	
9	VMP8589	AUDIO SW PLATE	1		80	VMZ3631	C. B. A. BARRIER	1	
10	VWJ12H2040L0	12PIN40MM FFC	1		81	VGF1050	DUSTPROOF SHEET	1	
11	VYK1Y37	BACK PANEL 1U	1		82	VGU9925	REC CHECK BUTTON	1	
12	VYK2J42	SIDE CASE R 1U	1		83	VGU9215	ZOOM LEVER	1	
12-1	VMG1286	CUSHION RUBBER	2		84	VMZ3406	ZOOM PCB BLIND SHEET	1	
12-2	VMZ3757	FPC PROTECTION SHEET A	1		85	VWJ1844	SIDE JACK FPC	1	
12-3	VYQ3806	IR SENSOR WINDOW	1		86	VMT1749	FFC FIX SHEET	2	
13	VYK1U47	LCD U	1		87	VEE1C05	BATTERY-POWER CABLE	1	
14	VGG8773	LCD HINGE COVER	1		88	VWJ06H2060L0	6PIN FFC	1	
15	VWJ06H2033L0	6PIN33MM FFC	1		89	VJF1468	XLR CAP	2	
16	VEKOJ73	IRIS DIAL U	1		90	VMT1774	CORE TAPE	1	
17	VGU9929	AWB BUTTON	1		91	JOKD00000103	CORE	1	
18	VSC5806	SIDE R HEAT SINK	1		92	VGU0D09	TOP OPERATION BUTTON	1	
19	VMP8615	TRIPOD FRAME	1		93	VGU9195	VTR KNOB	1	
20	VYQ3733	CLUTCH U	1		94	VGU9210	REC/DUB BUTTON	1	
20-1	VGU9936	CLUTCH KNOB	1		95	VMZ3768	RCA INSULATING SHEET	1	
20-2	VGP6167	CLUTCH PANEL	1		96	VSC6051	USB GROUND ANGLE	1	
20-3	VMP8557	CLUTCH FRAME	1		97	VYQ3897	RCA PLATE U	1	
21	VMP8558	CLUTCH ARM ANGLE	1		98	VMT1907	SOFT HIGH SHIELD GASKET	1	
22	VYK1Y38	BATTERY CASE 1U	1		99	VMT1896	FPC HOLD CUSHION	1	
23	VSC5801	CCD HEAT SINK	1						
24	VWJ10H2030L0	10PIN30MM FFC	1						
25	VWJ12H2050L0	12PIN50MM FFC	1		201	XQN2+B4FN	SCREW	76	
26	VWJ06H2045L0	6PIN45MM FFC	1		202	XQN2+BJ5FJK	SCREW	5	
27	VGU9894	SLIDE KNOB	4		203	XYN26+A6FJK	SCREW	2	
28	VGH4857	SLIDE KNOB SHEET	4		204	XQN2+BJ6FJ	SCREW	2	
29	VGU9931	LCD BUTTON B	1		205	XQN2+B4FJK	SCREW	27	
30	VGU9935	COUNTER BUTTON	1		206	XYN2+C5FJ	SCREW	2	
31	VGU9930	LCD BUTTON A	1		207	XQN2+BJ4FJK	SCREW	2	
32	VGU9937	EVF DTL BUTTON	1		208	XQN16+BJ4FJK	SCREW	4	
33	VGU9197	MONITOR LOCK KNOB	1		209	XQN2+A5FJK	SCREW	1	
34	VMB4017	FOCUS SPRING	1		210	VHD1887	SCREW	7	
35	VGG8772	CAM OP BACKUP	1						
36	VGU9928	ND KNOB	1						
37	VGU9926	FOCUS KNOB	1						
38	VGU9927	CAM OP BUTTON	1		E1	VEP03G90C	VTR C. B. A.	1	FOR AG-HVX200AP/AAN
39	VMP7331	OPENER HOLDER ANGLE	1		E1	VEP03G90D	VTR C. B. A.	1	FOR AG-HVX201AE/AEN/AMC/AER
40	VMB3996	POP UP SPRING	1		E2	VEP23655D	CAMERA C. B. A.	1	FOR AG-HVX200AP/AAN
41	VGG6901	MONITOR KNOB	1		E2	VEP23655E	CAMERA C. B. A.	1	FOR AG-HVX201AE/AEN/AMC/AER
42	VMS7187	LCD LOCK SHAFT	1		E3	VEP03G89F	CODEC C. B. A.	1	FOR AG-HVX200AP/AAN
43	VMB3659	MONITOR OPENER SPRING	1		E3	VEP03G89G	CODEC C. B. A.	1	FOR AG-HVX201AE/AEN/AMC/AER
44	VWJ06H2033L0	6PIN33MM FFC	1		E4	VEP001M6A	R SIDE C. B. A.	1	
45	VMP8552	JACK ANGLE	1		E5	VEP06G20A	CAM OP1 C. B. A.	1	
46	VWJ12H2120L0	12PIN120MM FFC	1		E6	VEP06G21A	CAM OP2 C. B. A.	1	
47	VWJ16H2145L0	16PIN145MM FFC	1		E7	VEP06G22A	CAM OP3 C. B. A.	1	
48	VGH4874	JACK PLATE	1		E8	VEP01978A	POWER C. B. A.	1	
49	VGU9721	AUDIO VR KNOB	2		E9	VEP03G92C	P2 CARD C. B. A.	1	
50	VYQ3547	MODE DIAL U	1		E11	VEP04904A	SIDE JACK2 C. B. A.	1	
51	VEE1C06	AUDIO CABLE	1		E12	VEP001P2A	SD CARD C. B. A.	1	
52	VWJ24H2030L0	24PIN30MM FFC	1		E14	VEP001M1C	TOP OP C. B. A.	1	
53	VEE1C12	1394 CABLE	1		E15	VEP001M2B	BACK PANEL C. B. A.	1	
54	K4Z204000036	BATTERY TERMINAL	1		E16	VEP04902C	SIDE JACK 1 C. B. A.	1	
55	VEE1C20	DC IN-BATTERY CABLE	1		E17	VEP04903B	EXT MIC 2 C. B. A.	1	
56	VMP7340	DCIN ANGLE	1		E21	VEP001M4A	POWER SW C. B. A.	1	
57	VYK1U97	SIDE COVER LU	1		E22	VEP01979A	BATTERY C. B. A.	1	
58	VGG9900	LINE SHEET	2		E23	VEP01971A	DC IN P. C. BOARD	1	
59	VJF1544	SD CARD CAP	1		E24	VEP001M5B	ZOOM SW C. B. A.	1	
60	VJF1545	USB COVER	1		E26	VEP22370A	GYRO C. B. A.	1	
61	VJF1541	JACK COVER	1		E27	VEP03G96A	CAMERA TOP FPC C. B. A.	1	
62	VSC5805	SHIELD PLATE B	1		E28	VEP03G94A	CODEC P2 FPC C. B. A.	2	
63	VSC5804	SHIELD PLATE A	1		E29	VEP001N2A	TOP CON C. B. A.	1	
64	VWJ1845	CAMERA TO SIDE CASE-R FPC	1						
65	VYQ3807	ZOOM SW 1 U	1						
66	VJF1543	SIDE JACK CAP B	1						
67	VJF1542	SIDE JACK CAP A	1						
68	VGH4876	JACK NAME PLATE 2	1						
69	VMZ3758	HINGE FPC HOLD SHEET	1						
70	VSC5850	P2 CARD SHIELD PLATE	1						

# HANDLE EVF PARTS ASSEMBLY

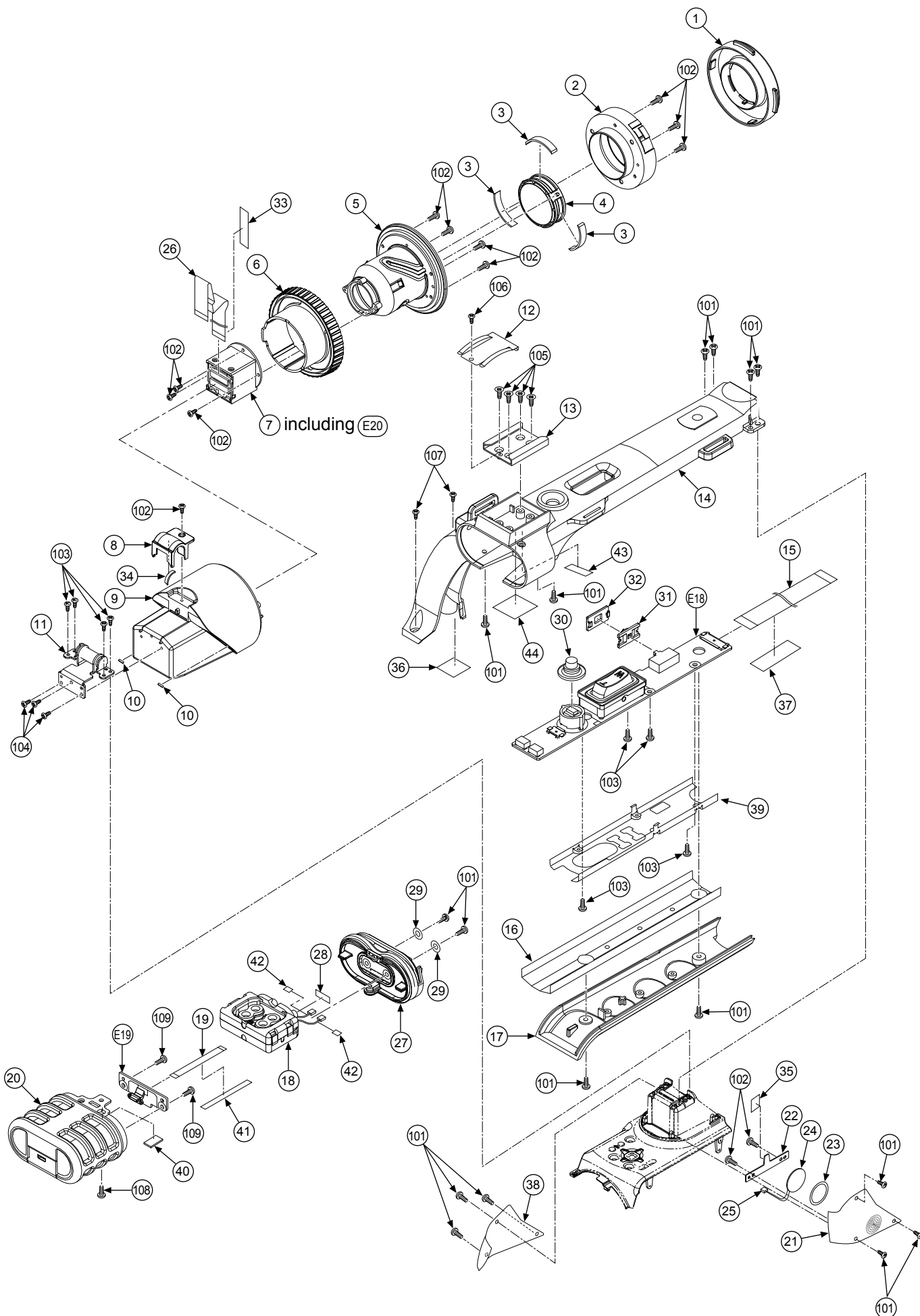



# LCD PARTS ASSEMBLY

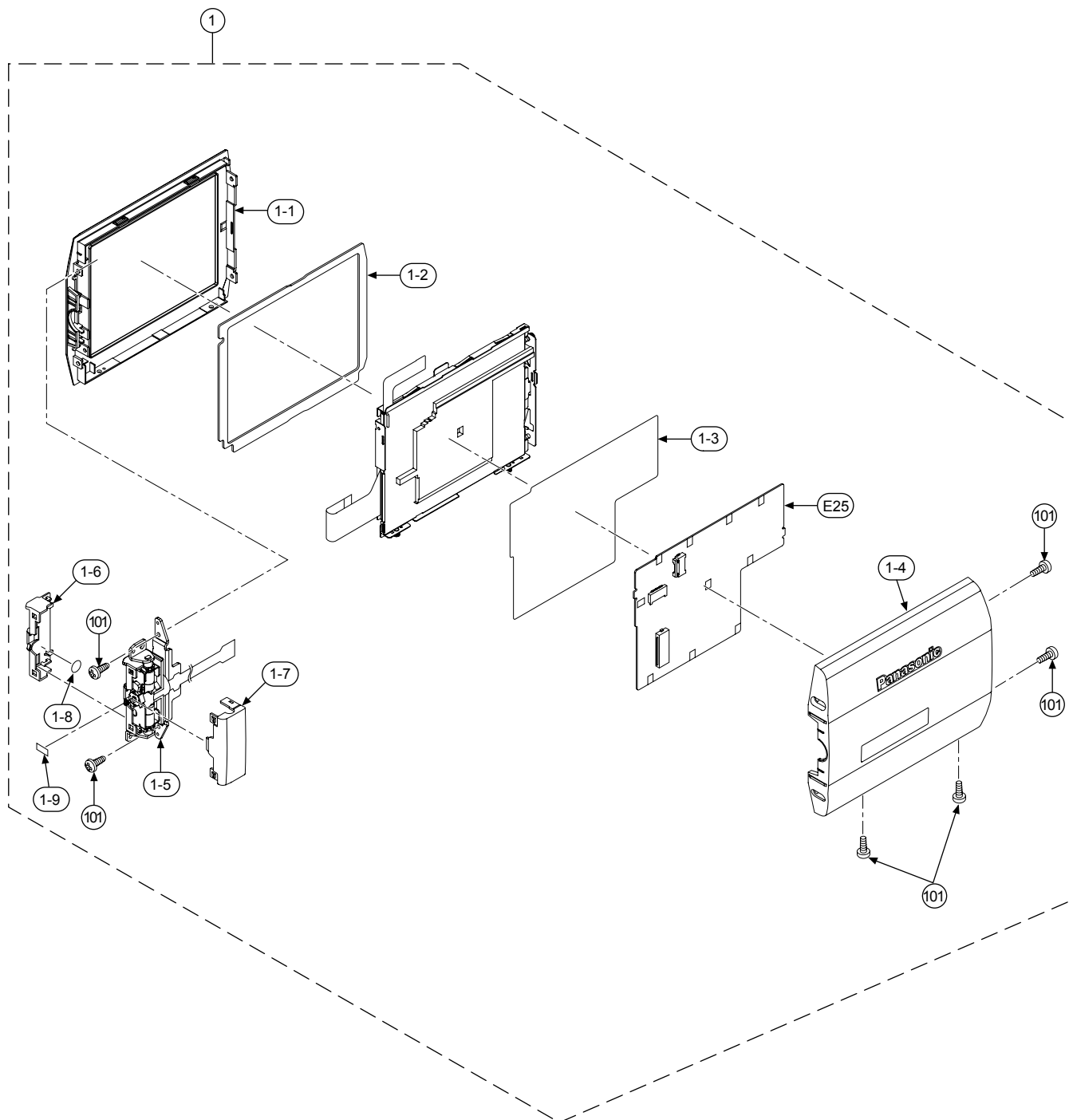





# PACKING PARTS ASSEMBLY

Components identified with the mark  have the special characteristics for safety. When replacing any of these components, use only the same type.

