

Einlochmischer
Mitigeur monotrou
Miscelatori monoforo
Mezclador monoblock
Single-hole faucets

mit festem Auslauf
avec bec fixe
con bocca fissa
con boca fija
with fixed spout

und Bidet
et pour bidet
e bidet
y para bidet
and for bidet

KWC DOMO
KWC ORCINO
KWC VITA
KWC FORMA
KWC STAR
KWC TRISTAR

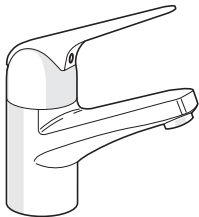

KWC DOMO
K.12.61.40/41/50/51

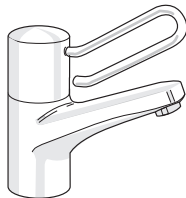

KWC VITA-UNO
K.12.U1.41/51

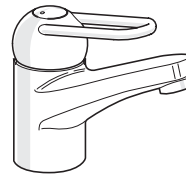

KWC VITA-DUO
K.12.T1.41/51

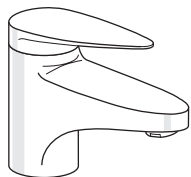

KWC ORCINO
K.12.71.42/52

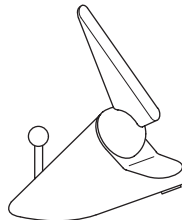

KWC FORMA
K.12.F1.41

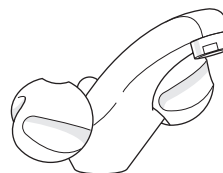

KWC STAR
K.12.41.42/52



KWC DOMO
K.25.R1.51

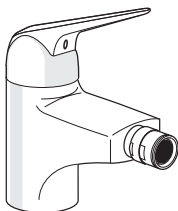

KWC DOMO
K.13.61.41

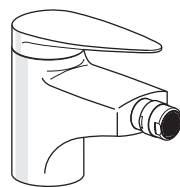

KWC ORCINO
K.13.71.41

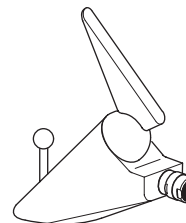

KWC FORMA
K.13.F1.41



KWC STAR
K.13.41.41

D Betriebsdaten:
 Idealer Betriebsdruck : 3 bar
 Max. Betriebsdruck : 5 bar
 Ideale Wassertemperatur : 60 °C
 Max. Wassertemperatur : 90 °C

F Caractéristiques de fonctionnement
 Pression de service idéale : 3 bar
 Pression de service max. : 5 bar
 Température idéale de l'eau : 60 °C
 Température max. de l'eau : 90 °C

I Caratteristiche di funzionamento
 Pressione di servizio ideale : 3 bar
 Pressione di servizio mass. : 5 bar
 Temperatura acqua calda ideale : 60 °C
 Temperatura acqua calda mass. : 90 °C

Achtung:
 ⚠ Vor Montage die Leitungen gründlich durchspülen!

Attention:
 ⚠ Rincer à fond la tuyauterie avant le montage!

Attenzione:
 ⚠ Risciacquare bene le tubazioni prima del montaggio!

Sp Características de funcionamiento
 Presión ideal de servicio : 3 bar
 Presión máxima de servicio : 5 bar
 Temperatura ideal del agua : 60 °C
 Temperatura máxima del agua : 90 °C

E Operating data
 Ideal operating pressure : 3 bar (45 PSI)
 Max. operating pressure : 5 bar (70 PSI)
 Ideal water temperature : 60 °C (140 °F)
 Max. water temperature : 90 °C (194 °F)

Atención:
 ⚠ Limpiar escrupulosamente las tuberías antes del montaje!

Attention:
 ⚠ Before installation flush pipes thoroughly!

Schweiz, Suisse:
 KWC AG
 Hauptstrasse 57
 CH-5726 Unterkulm

Deutschland:
 KWC Deutschland GmbH
 Rigipsstraße 15
 71083 Herrenberg 6

France:
 KWC Robinetterie S.a.r.l.
 Quartier d'Entreprises
 Rue Ettore Bugatti
 67200 Eckbolsheim

Italia:
 KWC Italia SRL
 Via A. Meucci, 54
 36057 Arcugnano (VI)

Oesterreich:
 KWC Armaturen GmbH
 Rottfeld 7
 5020 Salzburg

USA:
 KWC Faucets Inc.
 1770 Corporate Drive, #580
 Norcross, GA 30093

Tel. : 062 768 67 77
 Fax : 062 768 61 69

Tel. : 07032 7809 0
 Fax : 07032 7809 30

Tel. : 0388 78 88 08
 Fax : 0388 76 55 32

Tel. : 0 444 96 48 20
 Fax : 0 444 96 47 35

Tel. : 0662 433 100 0
 Fax : 0662 433 100 20

Phone: 678 334 2121
 Fax: 678 334 2128

Befestigung

Fixation

Fissaggio

Fijación

Connection

1**Stutzenbefestigung**

Fixation par tube fileté

Fissaggio con con codolo filettato

Fijación de las tubuladuras

Threaded connection mounting

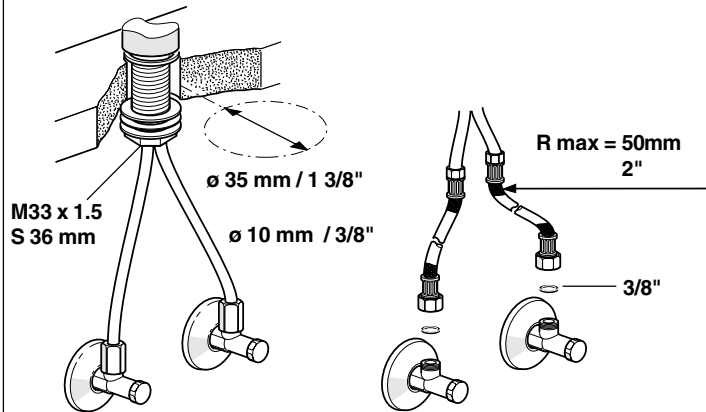
**Z.503.315**

D Für grössere Auflagedicken gibt es Verlängerungsmuttern 40 mm.
- Bohrung hierfür min.36 mm



F Pour les épaisseurs supérieures, utiliser l'écrou prolongé 40 mm.
- Perçage nécessaire au moins 36 mm

I Per spessori superiori ci sono i dadi prolungati 40 mm.
- Occorre un foro di almeno ø36 mm

Sp Para espesores de superficies de apoyo mayores se dispone tuercas de prolongación 40 mm.
- Perforación para tal caso, min. 36 mm

E Available for larger mounting surface thicknesses:
extension nuts 40 mm / 1 1/2"
- Bore for extension nut min. 36 mm / 1 1/2"

Stehbolzenbefestigung

Fixation par tige filetée

Fissaggio con asta filettata

Fijación de los espárragos

Stud bolt mounting

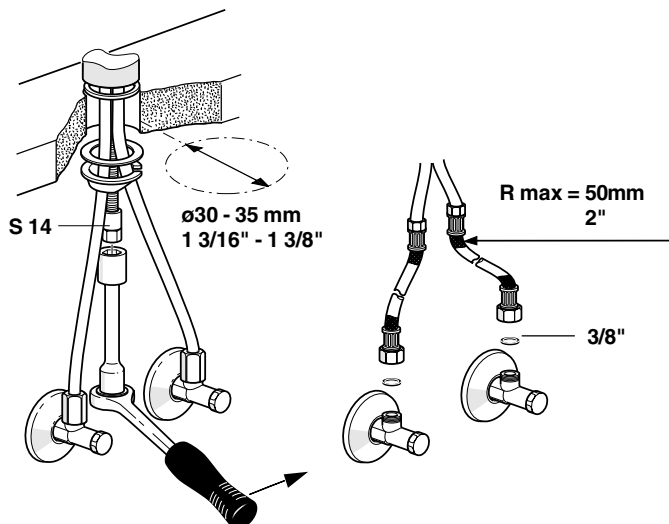
**Inbetriebsetzung**

Mise en service

Messa in funzione

Puesta en servicio

Taking in service

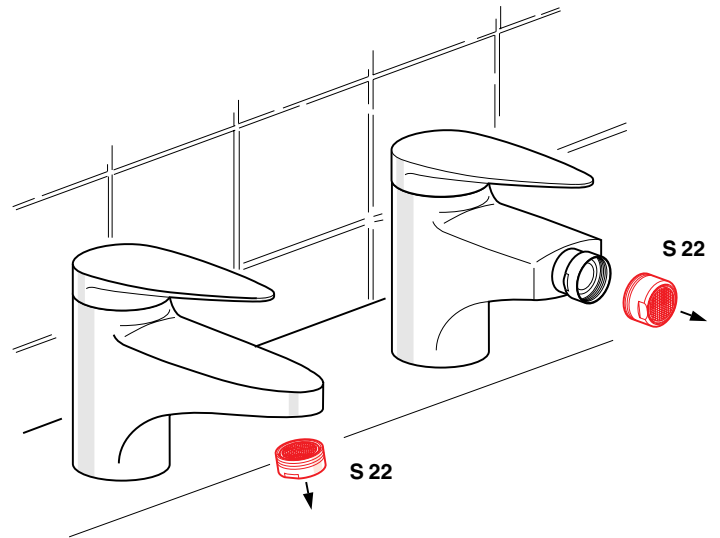
2

D - Eckreguliertventile öffnen.
- Mischer spülen.
(zuerst Neoperl demonstrieren).

F - Ouvrir les robinets d'arrêt.
- Rincer le mitigeur.
(démonter d'abord le Neoperl).

I - APrire i rubinetti a gomito.
- Sciacquare il miscelatore.
(dopo aver smontato il Neoperl).

Sp - Abrir las válvulas en ángulo de regulación.
- Lavar el mezclador.
(desmontar primero el aerador).

E - Open corner regulating valves.
- Flush with cold and hot water.
(First remove Neoperl aerator).

Mengenbegrenzung

Limitation du débit

Limitazione della portata

Limitación del caudal

Limitation of faucet flow rate

3

KWC ORCINO KWC DOMO KWC VITA-DUO

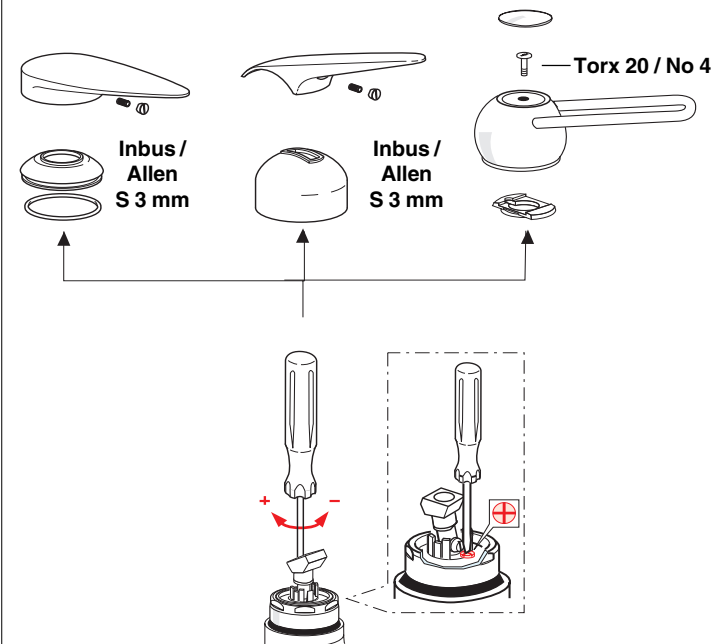

KWC VITA

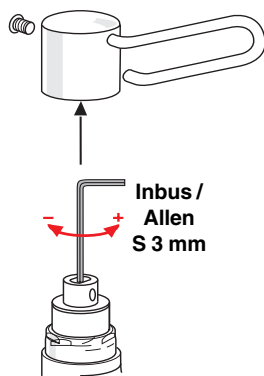

KWC STAR (Bidet)

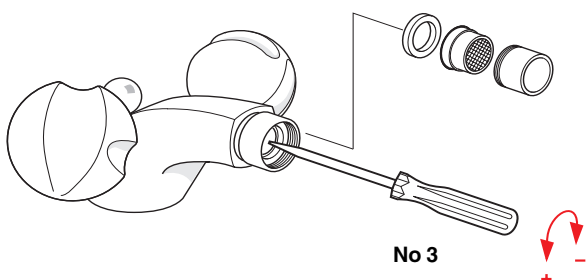

Höchsttemperaturbegrenzung

Limitation de la température max.

Limitazione della temperatura massima

Limitación de la temperatura máxima

Maximum temperature limitation

4

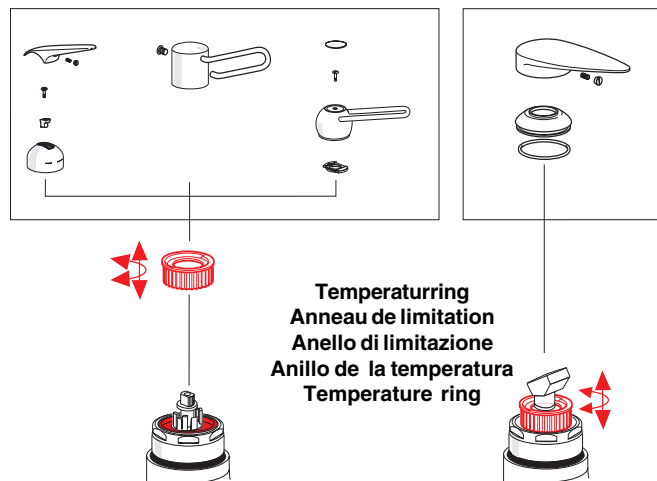

Max. Temperaturbereich :
 Plage de température max. :
 Campo di temperatura mass. :
 Gama de temperaturas máx. :
 Max. temperature range :

Begrenzter Temperaturbereich :
 Plage de température réduite :
 Campo di temperatura ridotto :
 Gama de temperaturas reducidas :
 Reduced temperature range :

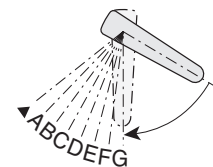
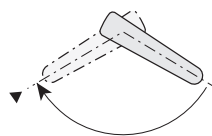
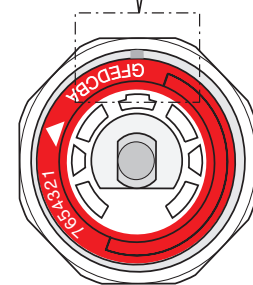
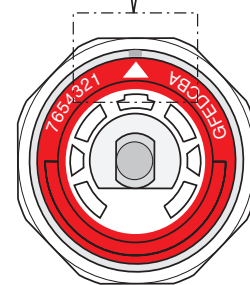
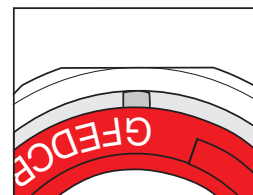
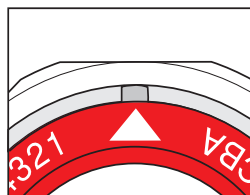

Pfeil auf Kerbe.
 Flèche sur encoche.
 Freccia su scanalatura.
 Flecha en la hendidura.
 Arrow on groove.

Position A - G.
 Position A - G.
 Position A - G.
 Posición A - G.
 Positions A - G.

Austausch der Steuerpatrone
Remplacement de la cartouche
Sostituzione della cartuccia
Recambio del cartucho de mando
Replacing of the control cartridge

5

KWC ORCINO KWC DOMO

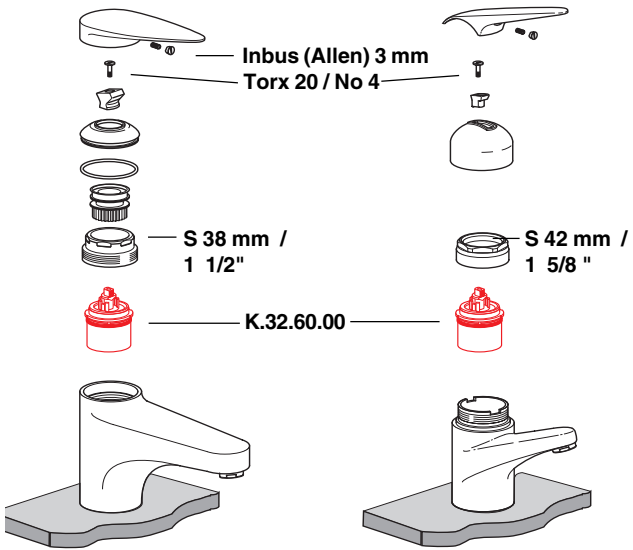

KWC VITA- UNO / DUO

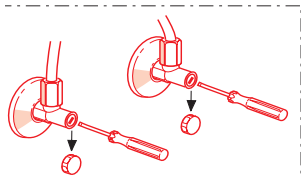
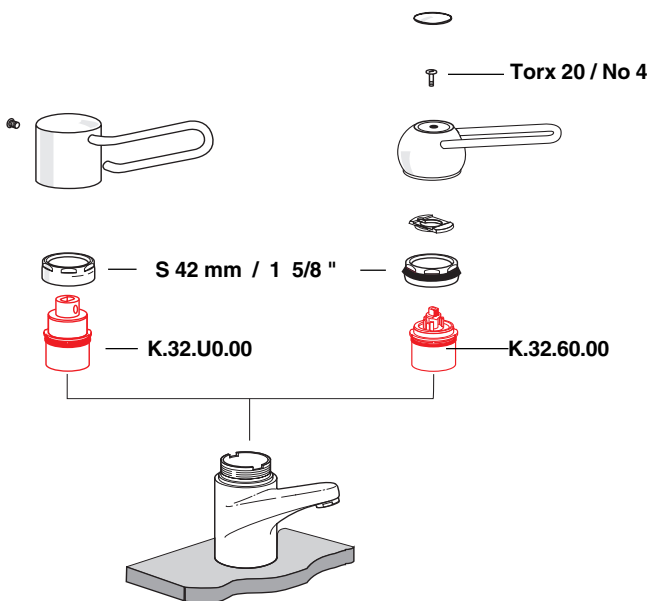

Kalt- und Warmwasser absperrn.
Fermer eau froide et chaude.
Chiudere acqua fredda e calda.
Interrumpir la salida de agua fría y caliente.
Turn off cold and hot water.

Ersatzteile
Pièces de rechange
Pezzi di ricambio
Repuestos
Spare parts

6

KWC ORCINO

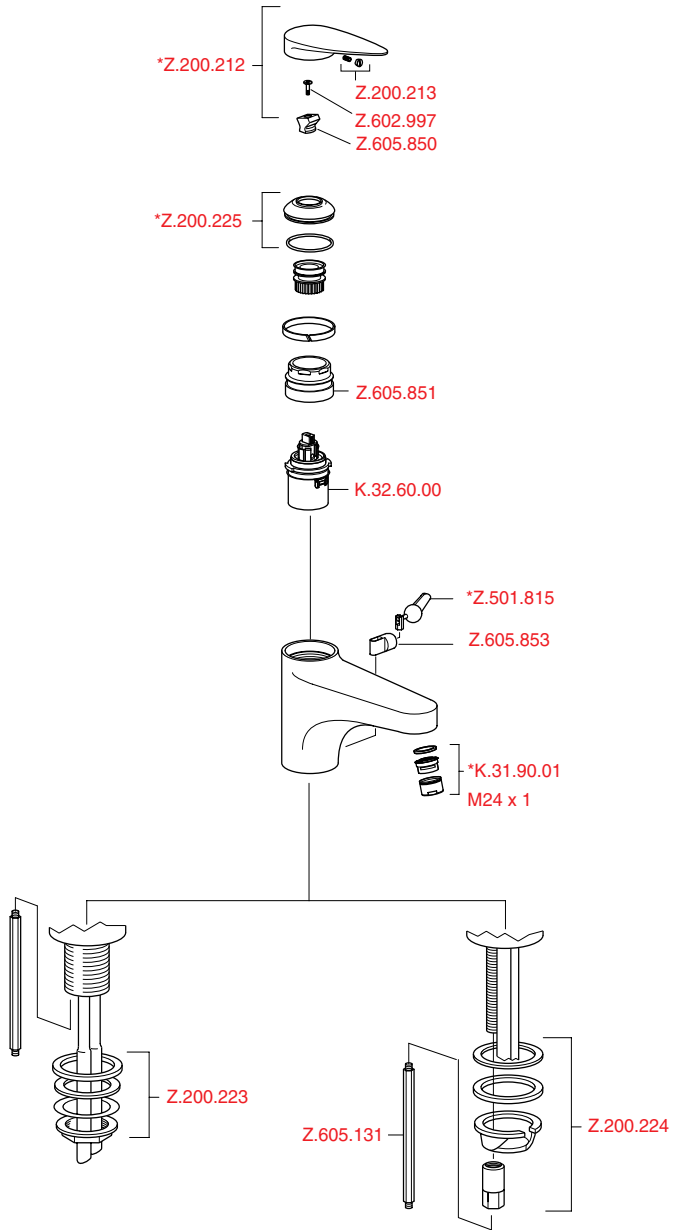

KWC DOMO

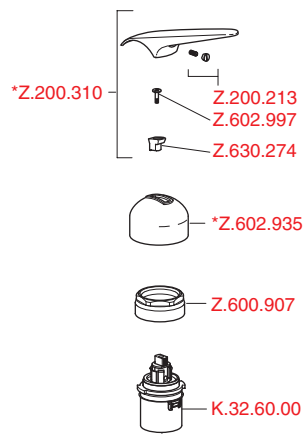

KWC VITA-UNO

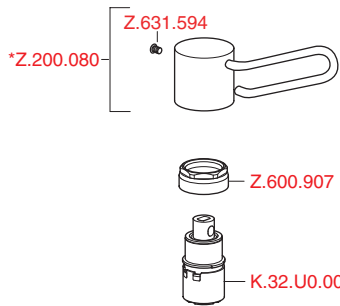

KWC VITA-DUO

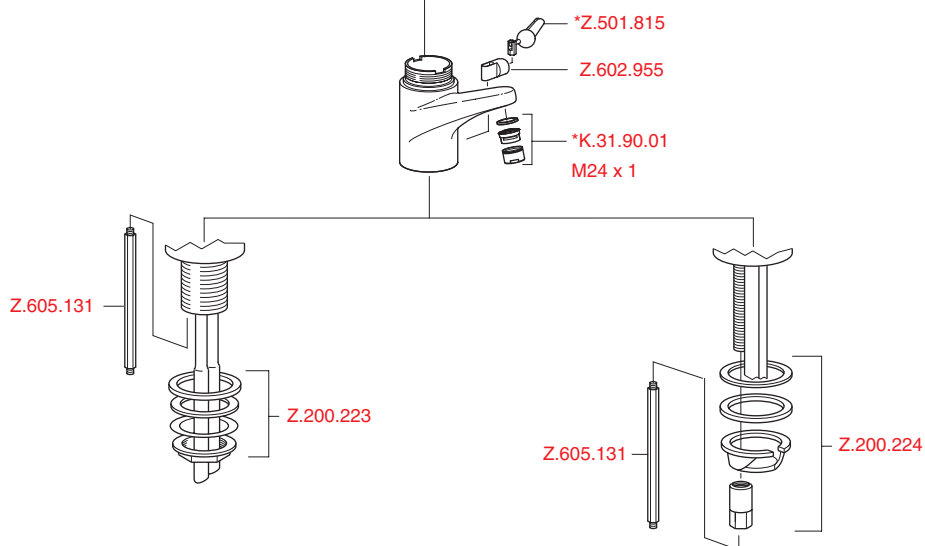
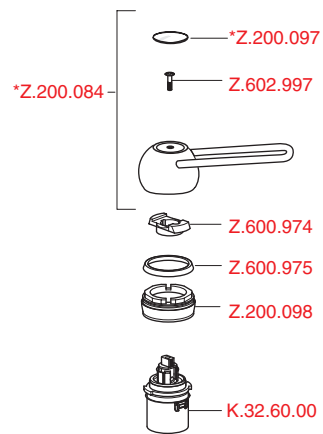

KWC FORMA

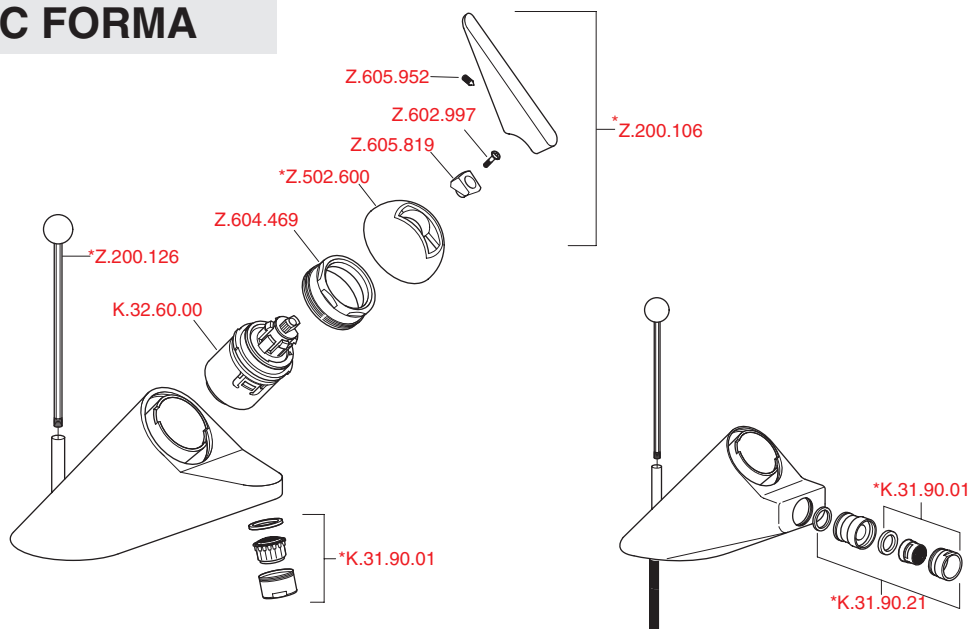

KWC DOMO

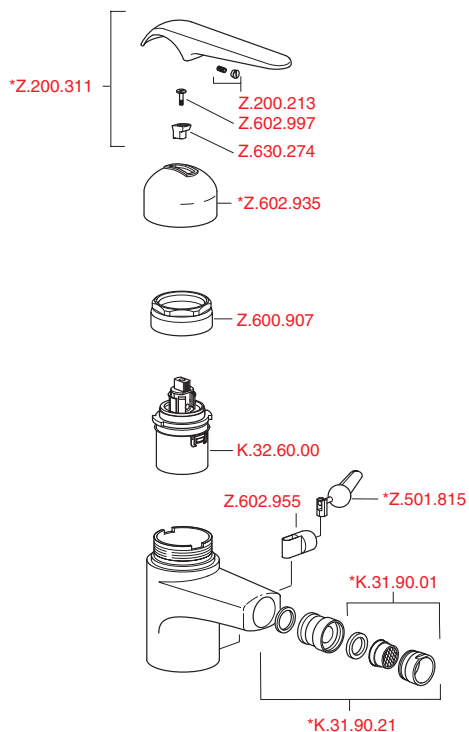

KWC ORCINO

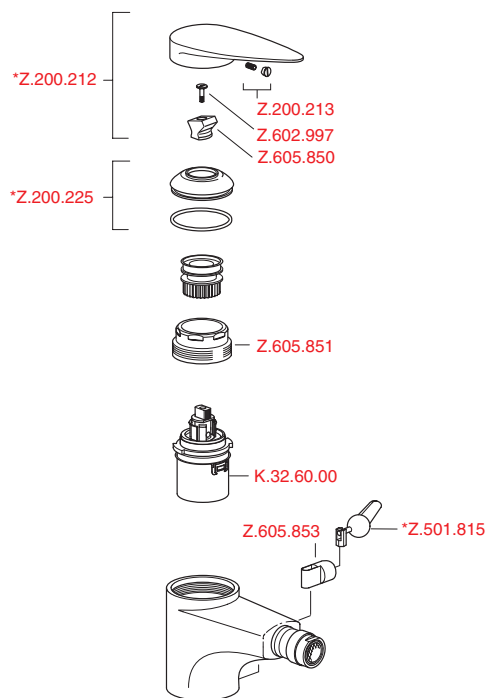

KWC STAR

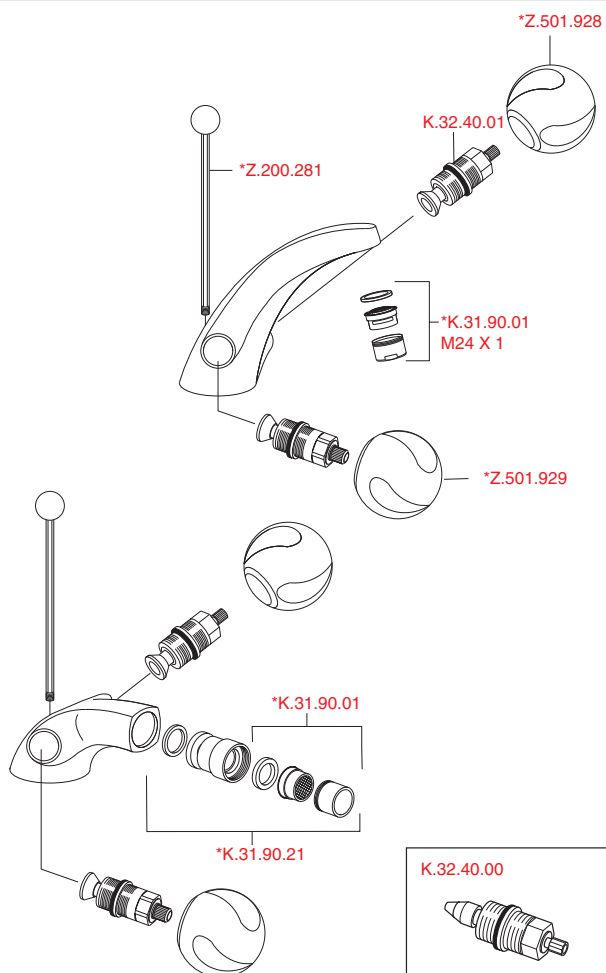

KWC TRISTAR

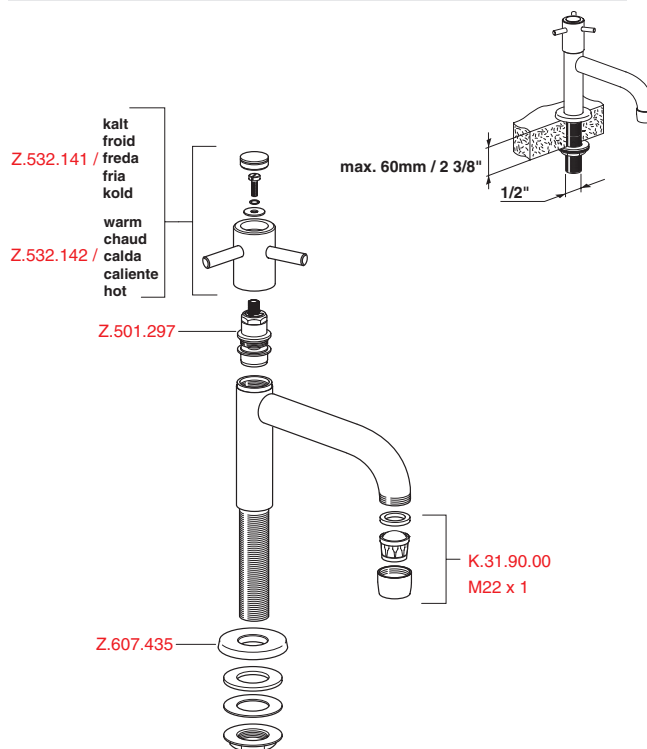

D * Bitte bei Bestellung Farbe angeben.
F * Lors de la commande, veuillez indiquer la couleur, s.v.p.
I * P.f., nell' ordinazione indicare il colore.
Sp * Rogamos indique el color al hacer el pedido.
E * Please specify the color when placing your order.