

# *Grizzly* *Industrial, Inc.*®

## MODEL H8213 14-PIECE ANGLE DIE GRINDER KIT INSTRUCTION MANUAL



COPYRIGHT © AUGUST, 2007 BY GRIZZLY INDUSTRIAL, INC.  
WARNING: NO PORTION OF THIS MANUAL MAY BE REPRODUCED IN ANY SHAPE  
OR FORM WITHOUT THE WRITTEN APPROVAL OF GRIZZLY INDUSTRIAL, INC.  
#JM9836 PRINTED IN CHINA

 **WARNING!**

**This manual provides critical safety instructions on the proper setup, operation, maintenance and service of this machine/equipment.**

**Failure to read, understand and follow the instructions given in this manual may result in serious personal injury, including amputation, electrocution or death.**

**The owner of this machine/equipment is solely responsible for its safe use. This responsibility includes but is not limited to proper installation in a safe environment, personnel training and usage authorization, proper inspection and maintenance, manual availability and comprehension, application of safety devices, blade/cutter integrity, and the usage of personal protective equipment.**

**The manufacturer will not be held liable for injury or property damage from negligence, improper training, machine modifications or misuse.**

 **WARNING!**

**Some dust created by power sanding, sawing, grinding, drilling, and other construction activities contains chemicals known to the State of California to cause cancer, birth defects or other reproductive harm. Some examples of these chemicals are:**

- **Lead from lead-based paints.**
- **Crystalline silica from bricks, cement and other masonry products.**
- **Arsenic and chromium from chemically-treated lumber.**

**Your risk from these exposures varies, depending on how often you do this type of work. To reduce your exposure to these chemicals: Work in a well ventilated area, and work with approved safety equipment, such as those dust masks that are specially designed to filter out microscopic particles.**

# SAFETY

## **WARNING**

### **For Your Own Safety Read Instruction Manual Before Operating This Equipment**

The purpose of safety symbols is to attract your attention to possible hazardous conditions. This manual uses a series of symbols and signal words which are intended to convey the level of importance of the safety messages. The progression of symbols is described below. Remember that safety messages by themselves do not eliminate danger and are not a substitute for proper accident prevention measures.



Indicates an imminently hazardous situation which, if not avoided, **WILL** result in death or serious injury.



Indicates a potentially hazardous situation which, if not avoided, **COULD** result in death or serious injury.



Indicates a potentially hazardous situation which, if not avoided, **MAY** result in minor or moderate injury. It may also be used to alert against unsafe practices.

**NOTICE**

This symbol is used to alert the user to useful information about proper operation of the equipment.

## **WARNING**

### **Safety Instructions For Pneumatic Tools**

- 1. READ THIS MANUAL.** This tool may cause personal injury if used incorrectly. This manual contains proper safety and operating instructions that must be followed to reduce this risk.
- 2. WEAR EYE PROTECTION.** This tool may throw small fragments during operation, which may cause serious eye injury. Always wear ANSI approved safety glasses or face shield to reduce your risk from this hazard.
- 3. WEAR A RESPIRATOR.** This tool may produce fine dust during operation, which can cause respiratory injury if inhaled. Always wear a respirator NIOSH approved for the type of material being processed.
- 4. WEAR HEARING PROTECTION.** Operating this tool for prolonged time periods may damage your hearing. Your risk depends on length and frequency of use. To reduce your risk of this hazard, wear hearing protection.
- 5. MAINTAIN SAFETY GUARDS.** Your tool may be equipped with safety guards or other structural components designed to reduce the risk of injury during operation. Never modify or operate this tool with any guards or components removed or damaged.
- 6. KEEP CHILDREN AWAY.** Prevent children from injury by keeping them away from this tool. Disconnect and lock the tool away when not in use.

7. **AVOID ENTANGLEMENTS.** Do not wear loose clothing, gloves, neckties, rings, bracelets, or other jewelry, which may get caught in moving parts, when operating this tool. Wear a protective hair covering to contain long hair.
8. **USE CORRECT AIR PRESSURE.** Exceeding the maximum PSI rating of this tool may cause unpredictable operation or bursting.
9. **DISCONNECT AIR PRESSURE** before servicing, changing accessories, or moving to another location. Never leave this tool unattended when connected to air.
10. **SECURE TOOLING.** Always verify tooling is secure before operation.
11. **SHARP SURFACES.** DO NOT place hands near the tooling surfaces when in operation.
12. **REMOVE ADJUSTING KEYS AND WRENCHES AFTER USE.** These tools become dangerous projectiles if left on the tool when it is started.
13. **AVOID FLAMMABLES.** Do not use this tool around any flammables that may be ignited by sparks.
14. **SECURE WORK.** Use clamps or a vise to hold work when practical. It is safer than using your hand and frees both hands to operate tool.
15. **MAINTAIN TOOLS WITH CARE.** Keep tools lubricated and clean for best and safest performance. Follow instructions for lubricating and changing accessories.
16. **DO NOT FORCE TOOL.** It will do the job better and safer at the rate for which it was designed.
17. **CHECK FOR DAMAGED PARTS BEFORE USING.** Check for binding and alignment of parts, broken parts, part mounting, loose bolts, and any other conditions that may affect operation. Repair or replace damaged parts before operating.
18. **USE GOOD LIGHTING.** Keep work area well lighted. Dark work areas increase risk of accidental injury.
19. **AVOID UNINTENTIONAL OPERATION.** Always disconnect air when not in use, and do not carry tool with hand on trigger.
20. **USE THE RECOMMENDED ACCESSORIES.** Consult owner's manual for recommended accessories. Using improper accessories may increase the risk of injury.
21. **NEVER ALLOW UNTRAINED USERS TO USE THIS TOOL WHILE UNSUPERVISED.**
22. **IF YOU ARE UNSURE OF THE INTENDED OPERATION, STOP USING TOOL.** Seek formal training or research books or magazines that specialize in pneumatic tools.
23. **BE AWARE OF HOSE LOCATION.** Hoses can easily become a tripping hazard when laid across the floor in a disorganized fashion.
24. **DO NOT USE UNDER THE INFLUENCE OF DRUGS OR ALCOHOL, OR WHEN TIRED.**

## CAUTION

No list of safety guidelines is complete, because every work environment is different. Always consider safety first and use common sense. Failure to use this tool with caution and respect could result in serious personal injury.

# INTRODUCTION

## Foreword

The specifications, details, and photographs in this manual represent the Model H8213 as supplied when the manual was prepared. However, owing to Grizzly's policy of continuous improvement, changes may be made at any time with no obligation on the part of Grizzly.

If you have any comments regarding this manual, please write to us at the following address:

Grizzly Industrial, Inc.  
C/O Technical Documentation  
P.O. Box 2069  
Bellingham, WA 98227-2069  
E-Mail: manuals@grizzly.com

Most importantly, we stand behind our tools. If you have any service questions or parts requests, please call or write us at the location listed below.

Grizzly Industrial, Inc.  
1203 Lycoming Mall Circle  
Muncy, PA 17756  
Phone: (570) 546-9663  
Fax: (800) 438-5901  
E-Mail: techsupport@grizzly.com  
Web Site: <http://www.grizzly.com>

## Specifications

Collet Size..... $\frac{1}{4}$ " and  $\frac{1}{8}$ "  
No Load Speed.....20,000 RPM  
Air Consumption.....3 CFM  
Air Inlet..... $\frac{1}{4}$ "  
Required PSI.....90 PSI  
Maximum Sound Level.....94 dB

## Inventory

H8213 Inventory	Qty
A. Case.....	1
B. $\frac{1}{4}$ " Angle Die Grinder.....	1
C. Wrenches (12mm, 17mm).....	1 each
D. $\frac{1}{4}$ " NPT Male Quick Connect Fitting..	1
E. $\frac{1}{8}$ " Collet.....	1
F. Grinder Stone Bits.....	10

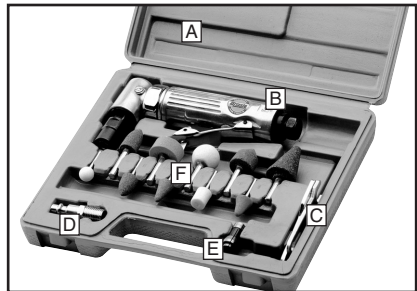
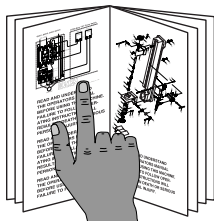

Figure 1. Model H8213 Inventory.

# OPERATIONS

## **!WARNING**



Read the manual before operation. Become familiar with this tool, its safety instructions, and its operation before beginning any work. Serious personal injury may result if safety or operational information is not understood or followed.

## **!WARNING**

DO NOT use bits or cutters with a cutting diameter larger than 1". The bit or cutter could break apart under the stresses of high speed use, causing serious personal injury.

## **!WARNING**

Like all tools there is potential danger when operating this tool. Accidents are frequently caused by lack of familiarity or failure to pay attention. If normal safety precautions are overlooked or ignored, serious personal injury may occur.

## Installing Bits

The Model H8213 uses bits and cutters with a 1/4" and 1/8" diameter shaft. See the Grizzly catalog or [www.grizzly.com](http://www.grizzly.com) for a complete listing of available bits and accessories.

### To install a bit:

1. DISCONNECT THE GRINDER FROM THE AIR SUPPLY!
2. Use the two included wrenches to loosen the collet nut, as shown in **Figure 2**.

**Note:** It is not necessary to completely remove the collet nut from the shaft unless you are also changing the collet.



**Figure 2.** Loosening the collet.

3. Insert at least 1/2" of the bit into the collet.
4. Hand tighten the collet nut, then use the collet wrenches to fully tighten. Verify that the tooling bit is secure and will not pull out.

## Using the Grinder

Always test the tooling bit on a scrap piece of material similar to the workpiece. Trial and error is the best way to determine the ideal setup.

### To use the grinder:

1. Attach the 1/4" NPT male quick connect fitting to the air inlet plug.
2. Attach the grinder to an air supply set at 90 PSI.
3. Hold the grinder securely.
4. Turn the grinder **ON** by depressing the trigger.
5. Securely holding the grinder, ease the working end of the bit against the workpiece with a light, but steady, pressure.
6. To turn the grinder **OFF**, release the trigger.
7. To avoid accidental starting, disconnect the grinder from the air supply when it is not in use.

## Daily Maintenance

The die grinder **MUST** have 2-6 drops of oil directly dropped into the air fitting before each use. In addition, we recommend using an in-line filter, lubricator, and regulator, as shown in **Figure 3**.

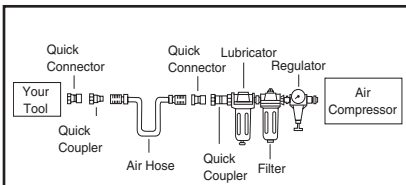

**Figure 3.** Installed filter lubricator regulator.

<b>! WARNING</b>	
	<b>LUNG/EAR INJURY HAZARD!</b> Wear protective equipment when using this tool.
	<b>ACCIDENTAL START HAZARD!</b> Disconnect before service or tool changes.
	<b>AIR PRESSURE HAZARD!</b> Never exceed max PSI rating for tool.
	<b>EYE INJURY HAZARD!</b> Wear protective equipment when using this tool.

The die grinder **MUST** also have 2-6 drops of gear lubricating oil directly dropped into the oil valve located in the angle housing, as shown in **Figure 4**.

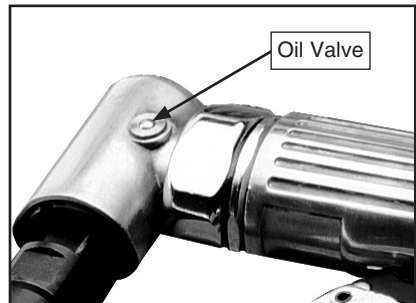
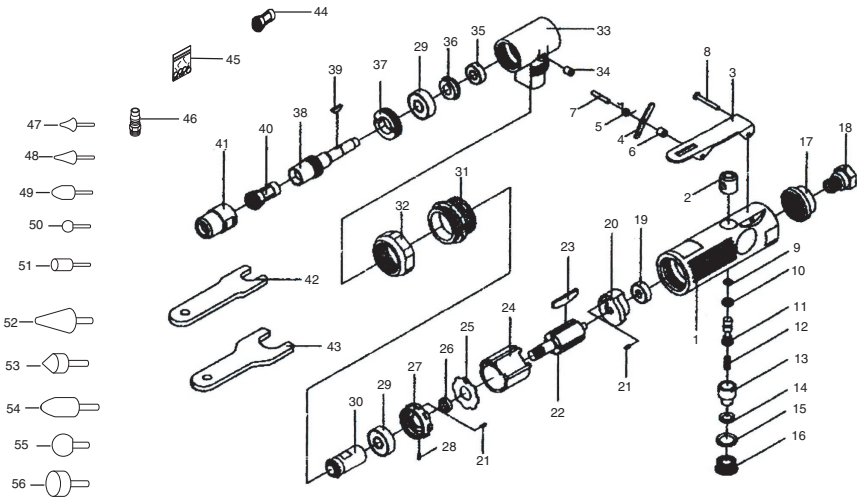

**Figure 4.** Oil valve location.

**These procedures should be done after each use:**

- Wipe the motor housing and tool bits with a dry cloth, or blow off the dust and debris with compressed air.
- Check for damage to tooling, hoses, housing or other accessories.

# PARTS LIST



REF PART #	DESCRIPTION
1	PH8213001 HOUSING
2	PH8213002 VALVE STEM SEAT
3	PH8213003 TRIGGER
4	PH8213004 TRIGGER THROTTLE
5	PH8213005 TORSION SPRING
6	PH8213006 TRIGGER RING
7	PH8213007 ROLL PIN 1.5 X 20
8	PRP16M ROLL PIN 3 X 25
9	PORS004 O-RING 3.5 X 1.5 S4
10	POR0004 O-RING 4 X 2
11	PH8213011 VALVE STEM
12	PH8213012 COMPRESSION SPRING
13	PH8213013 AIR REGULATOR
14	PORP007 O-RING 6.8 X 1.9 P7
15	PORP011-2 O-RING 11 X 2.4 P11.2
16	PH8213016 SCREW CAP
17	PH8213017 MUFFLE COVER
18	PH8213018 AIR INLET PLUG
19	P625 BALL BEARING 625ZZ
20	PH8213020 END PLATE
21	PH8213021 BOLT M2-.4 X 6
22	PH8213022 ROTOR
23	PH8213023 ROTOR BLADE
24	PH8213024 CYLINDER
25	PH8213025 WASHER
26	PH8213026 BUSHING
27	PH8213027 FRONT PLATE
28	PRP54M ROLL PIN 1.5 X 4

REF PART #	DESCRIPTION
29	P608A BALL BEARING 608
30	PH8213030 GEAR WHEEL
31	PH8213031 RETAINER RING
32	PH8213032 SCREW CAP
33	PH8213033 ANGLE HOUSING
34	PH8213034 OIL VALVE
35	PH8213035 BALL BEARING R4
36	PH8213036 GEAR WHEEL
37	PH8213037 THREADED RING
38	PH8213038 ROTATION AXIS
39	PH8213039 SEMICIRCULAR KEY
40	PH8213040 COLLET 1/4"
41	PH8213041 COLLET NUT
42	PH8213042 12MM FLAT WRENCH
43	PH8213043 17MM FLAT WRENCH
44	PH8213044 1/4" NPT MALE FITTING
45	PH8213045 O-RING KIT
46	PH8213046 COLLET 1/8"
47	PH8213047 PINK MUSHROOM 1/8"
48	PH8213048 GRAY MUSHROOM 1/8"
49	PH8213049 GRAY BULLET 1/8"
50	PH8213050 WHITE BALL 1/8"
51	PH8213051 WHITE CYLINDER 1/8"
52	PH8213052 GRAY CONE 1/4"
53	PH8213053 GRAY POINTED CYLINDER 1/4"
54	PH8213054 GRAY BULLET 1/4"
55	PH8213055 WHITE BALL 1/4"
56	PH8213056 PINK CYLINDER 1/4"