

INSTALLATION, OPERATION and MAINTENANCE MANUAL
for Cres Cor
CONVECTION and RETHERM OVENS
with MICROPROCESSOR CONTROLS



CO151FUA12B-Q1
CO151FPUA12B-Q1
CO151F1818B-Q1
RO151FUA18B-Q1
RO151F1332B-Q1



CO151HUA6B-Q1
CO151H189B-Q1
CO151XUA5B-Q1
CO151X185B-Q1

Ovens with Microprocessor Controls	FL-2269
Rev. 10 (6/08)	Page 2 of 13

TABLE OF CONTENTS

SUBJECT	PAGE
INSTALLATION INSTRUCTIONS	3, 4
OPERATING INSTRUCTIONS	4, 5, 6
Illustration, Figure 1	4
MAINTENANCE INSTRUCTIONS	
How to Clean the Unit	6
Trouble Shooting Guide	6, 7
Replacement Parts	8, 9
Illustrations; Hot Unit (Figures 3 and 4)	10, 11
Wiring Diagrams	12
OPTIONAL PRODUCT KEYS	13
SERVICE POLICY and AGENCY LIST	FL-1400

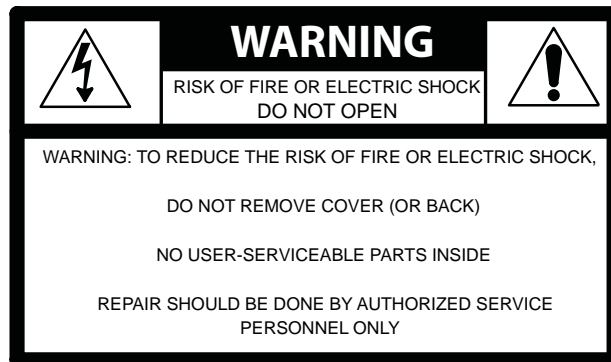

INSTALLATION INSTRUCTIONS

VENTING YOUR OVEN:

- The purpose of ventilating hoods is to direct and capture smoke, grease-laden vapors, heat, odors, or fumes.
- Low temperature equipment (maximum temperature 250°F/121°C) does not produce heat, odors, fumes, grease-laden vapors or smoke and is not required to be vented.
- Most jurisdictions consider our low-temperature ovens (maximum temperature is 350°F/177°C) as low-heat appliances not requiring vent hoods.
- Installation must conform with local codes. The authority having jurisdiction of enforcement of the codes will have the responsibility for making interpretations of the rules.

UNIT SPECIFICATIONS: All units use three (3) elements (2670 watts each).

All units are rated 8200 watts. Water units have one (1) immersion element (1850 watts).

MODEL NOS.	ELECTRICAL SPECS (AC SERVICE)			ELEC. LOAD		POWER SUPPLY REQUIREMENT ALL 3 PHASE IS 3 WIRE + GROUND			
	Volts	Ph	Hz.	Amps	Volts	Amps	Ph	Volts	NEMA
CONVECTION OVENS									
CO151FUA12B2081Q1	208	1	60	39	208	50	1	208	6-50P
CO151FUA12B2401Q1	240	1	60	34	240	50	1	240	6-50P
CO151FUA12B2083Q1	208	3	60	23	208	30	3	208	L15-30P
CO151FUA12B2403Q1	240	3	60	20	240	30	3	240	L15-30P
CO151FPUA12B2081Q1	208	1	60	39	208	50	1	208	6-50P
CO151FPUA12B2401Q1	240	1	60	34	240	50	1	240	6-50P
CO151FPUA122083Q1	208	3	60	23	208	30	3	208	L15-30P
CO151FPUA122403Q1	240	3	60	20	240	30	3	240	L15-30P
CO151F1818B2081Q1	208	1	60	39	208	50	1	208	6-50P
CO151F1818B2401Q1	240	1	60	34	240	50	1	240	6-50P
CO151F1818B2083Q1	208	3	60	23	208	30	3	208	L15-30P
CO151F1818B2403Q1	240	3	60	20	240	30	3	240	L15-30P
RETHERM OVENS									
RO151FUA18B2081Q1	208	1	60	39	208	50	1	208	6-50P
RO151FUA18B2401Q1	240	1	60	34	240	50	1	240	6-50P
RO151FUA18B2083Q1	208	3	60	23	208	30	3	208	L15-30P
RO151FUA18B2403Q1	240	3	60	20	240	30	3	240	L15-30P
RO151F1332B2081Q1	208	1	60	39	208	50	1	208	6-50P
RO151F1332B2401Q1	240	1	60	34	240	50	1	240	6-50P
RO151F1332B2083Q1	208	3	60	23	208	30	3	208	L15-30P
RO151F1332B2403Q1	240	3	60	20	240	30	3	240	L15-30P
HALF-SIZE OVENS Are rated at 4700 watts (three [3] heaters at 1470 watts each)									
CO151HUA6B2081Q1	208	1	60	24	208	30	1	208	6-30P
CO151HUA6B2401Q1	240	1	60	21	240	30	1	240	6-30P
CO151HUA6B2083Q1	208	3	60	15	208	20	3	208	L15-20P
CO151HUA6B2403Q1	240	3	60	13	240	20	3	240	L15-20P
CO151H189B2081Q1	208	1	60	24	208	30	1	208	6-30P
CO151H189B2401Q1	240	1	60	21	240	30	1	240	6-30P
CO151H189B2083Q1	208	3	60	15	208	20	3	208	L15-20P
CO151H189B2403Q1	240	3	60	13	240	20	3	240	L15-20P
CO151XUA5B2081Q1	208	1	60	24	208	30	1	208	6-30P
CO151XUA5B2401Q1	240	1	60	21	240	30	1	240	6-30P
CO151XUA5B2083Q1	208	3	60	15	208	20	3	208	L15-20P
CO151XUA5B2403Q1	240	3	60	13	240	20	3	240	L15-20P
CO151X185B2081Q1	208	1	60	24	208	30	1	208	6-30P
CO151X185B2401Q1	240	1	60	21	240	30	1	240	6-30P
CO151X185B2083Q1	208	3	60	15	208	20	3	208	L15-20P
CO151X185B2403Q1	240	3	60	13	240	20	3	240	L15-20P

All models are designed for AC Service. Model numbers may have the letters: **P, L, M, I, Q5, Q10** or **S**.

Ovens with Microprocessor Controls	FL-2269
Rev. 10 (6/08)	Page 4 of 13

INSTALLATION INSTRUCTIONS *(continued)*

HOW TO INSTALL CABINETS:

1. Remove all packing material from inside and outside of cabinet.
2. Position cabinet on level floor; install the cabinet interior (pan slides) if not already installed.
3. Plug power cord into proper wall receptacle.

Note: Cold food is NOT to be added when unit is operating in HOLD mode. For HOLD mode, preheat unit to 180°F/82°C for 60 minutes.



To install stacking units, refer to instruction sheet FL-2211, **Stacking Installation.**

OPERATING INSTRUCTIONS

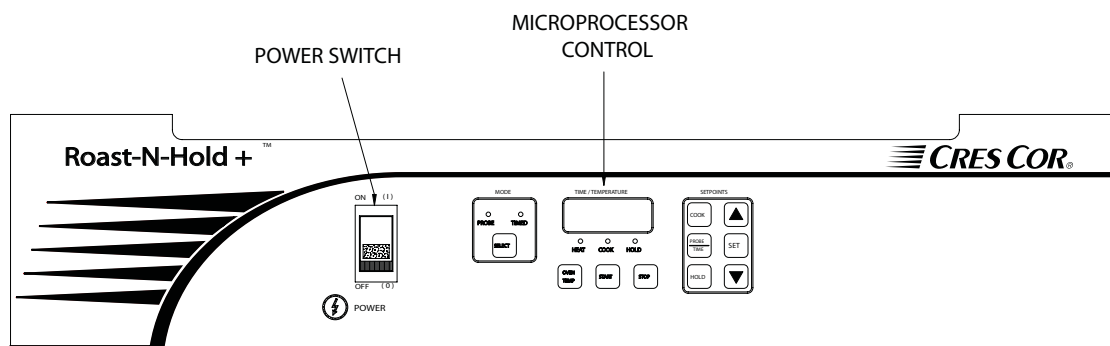

Figure 1: Control Panel

HOW TO START UNIT:

(for first-time operation only)

A new oven needs to “burn off” factory oils and glue before it’s first use. **Do NOT load food into oven until this has been done!**

1. Push power switch to “ON”.
2. Press the SELECT button; choose the TIMED mode.
3. Press the **COOK** button and set the temperature to 350°F/177°C.
4. Press the **HOLD** button and set the temperature to 150°F/66°C.
5. Press the PROBE/TEMP button and set the timer to one (1) hour.
6. Allow oven to run automatically for one (1) hour of **COOK/RETERM** cycle and 30 minutes of **HOLD** cycle.

HOW TO SET THE CONTROL FOR TIMED COOK OPERATION:

Press the SELECT button to choose the TIMED mode.

COOKING TIME:

1. Press the PROBE/TIME button. The display will show the cook/retherm time.
2. Use the UP and DOWN arrows to set the desired time.
3. Press the SET button to enter the time into the control.

COOKING TEMPERATURE:

1. Press the COOK button and the display will show the cook/retherm temperature.
2. Use the UP and DOWN arrows to set the desired temperature.
3. Press the SET button to enter the temperature into the control.

NOTE: Press the OVEN TEMP button at any time to view the actual oven temperature.

HOLDING TEMPERATURE:

For HOLD mode, preheat unit to 180°F/82°C for 60 minutes.

1. Press the HOLD button; the display will show the holding temperature.
2. Use the UP and DOWN arrows to set the desired temperature.

NOTE: Proper food holding temperature is 140°F/60°C or higher.

3. Press the SET button to enter the temperature into the control.
4. Press the START button and the display shows the remaining time in the cook/retherm cycle.

NOTE: The control will beep after it times down to zero; it will then automatically switch to the HOLD mode. The display will then show the hold setpoint temperature.

OPERATING INSTRUCTIONS (*continued*)

HOW TO SET THE CONTROL, *continued*

FOR PROBE COOK OPERATION:

Press the SELECT button to choose the probe mode.

PROBE TEMPERATURE:

1. Press the PROBE/TIME button. The display will show the probe setpoint temperature.
2. Use the UP and DOWN arrows to set the desired temperature.
3. Press the SET button to enter the temperature into the control.

NOTE: Press the OVEN TEMP button at any time to view the actual oven temperature. Press the START button and the display will show the actual probe temperature.

NOTE: The control will beep when the probe setpoint temperature has been reached and then will automatically switch to HOLD mode. The display will then show the hold setpoint temperature.

To manually end the COOK/RETERM, PROBE, or HOLD mode:

Press the STOP button during any of the above modes and the control will end that mode. If in the Cook/Retherm or Probe mode, the control will automatically switch into the HOLD mode.

HOW TO OPERATE WITH FOOD:

Manual (Timed mode) Operation

See “HOW TO SET THE CONTROL” (on page 4) for programming instructions.

1. Push power switch to “ON”.
2. Press the SELECT button and choose the TIMED mode.
3. Press the COOK button and set to desired temperature.
4. Press the PROBE/TIME button and set to the desired time.
5. Press the HOLD button; set desired temperature.
6. Place the food into oven. Close door and double check cooking time and temperatures. Then press the START button to start the cooking/retherm cycle and the Cook LED will light up.

7. The oven will beep and automatically switch to the HOLD mode at the end of the cooking cycle. The Cook lamp will go out and the Hold lamp will light up.

Probe Cooking

See “HOW TO SET THE CONTROL” (on page 5) for programming instructions.

1. Push power switch to “ON”.
2. Press the SELECT button and choose the Probe mode.
3. Insert the probe jack into the receptacle located inside the oven top, near the fans. The probe temperature display will show the digital temperature of the probe.
4. Put sanitized probe into center of food product. Make sure food is in the center of the pan and the pan is centered in the oven.
5. Press the start button. The cook lamp will light up and the display will show the internal temperature of the food being cooked.

NOTE: Do NOT change the mode of the controls (probe or timed) while oven is operating in a Cook/Retherm cycle. Oven must be in the HOLD cycle to change the timer or probe operation.

HOW TO SET HOLD-ONLY MODE:

1. Push power switch to “ON”.
2. Press the STOP button and oven will switch to HOLD cycle.
3. Press the HOLD button and set the desired hold temperature.

NOTE: Cold food is **NOT** to be added when unit is operating in **HOLD** mode. For **HOLD** mode, preheat unit to 180°F/82°C for 60 minutes.

HOW TO SHUT DOWN OVEN:

Push switch to “OFF”.



Ventilating fans will continue to run until the cabinet is cool. Do **NOT** disconnect the power supply to the cabinet while the ventilating fan is still operating.

Ovens with Microprocessor Controls	FL-2269
Rev. 10 (6/08)	Page 6 of 13

OPERATING INSTRUCTIONS (*continued*)

WARNING

BEFORE cleaning the cabinet:

1. **Unplug cord from wall. Allow cabinet to cool.**
2. **Do NOT hose cabinet with water.**
3. **Do NOT get water on controls.**
4. **Do NOT use abrasives or harsh chemicals.**
 - Wipe up spills as soon as possible.
 - Clean regularly to avoid heavy dirt build-up.

Cleaning Hints:

1. Use the mildest cleaning procedure that will do the job.
2. Always rub in the direction of the polish lines to avoid scratching the surface.
3. Use only a soft cloth, sponge, fibrous brushes, plastic or stainless steel pad for cleaning and scouring.
4. Rinse thoroughly with fresh water after every cleaning operation.
5. Always wipe dry to avoid water marks.

HOW TO CLEAN THE UNIT:

	SOIL	CLEANER	METHOD
CABINET Inside and Outside (Stainless Steel)	ROUTINE CLEANING	Soap, ammonia or mild detergent* and water.	1. Sponge on with cloth 2. Rinse
	STUBBORN SPOTS, STAINS	Mild abrasive made for Stainless Steel.	1. Apply with damp sponge or cloth. 2. Rub lightly.
	BURNT ON FOODS OR GREASE	Chemical oven cleaner made for Stainless Steel.	Follow oven cleaner manufacturer's directions.
	HARD WATER SPOTS & SCALE	Vinegar	1. Swab or wipe with cloth. 2. Rinse and dry.
* <i>Mild detergents include soaps and non-abrasive cleaners</i>			

MAINTENANCE INSTRUCTIONS TROUBLE-SHOOTING GUIDE

WARNING

**IF UNIT GETS TOO HOT OR WON'T SHUT OFF, DISCONNECT
POWER AT BRANCH PANEL. DO NOT UNPLUG CORD!**

If hot unit is *NOT* working, first check the following causes:

1. Cord is unplugged from wall outlet.
2. Circuit breaker/fuse to wall outlet is blown.
3. Switch is turned off.
4. Thermostat is turned off, or is set too low.

MAINTENANCE INSTRUCTIONS TROUBLE-SHOOTING GUIDE *(continued)*

PROBLEM	POSSIBLE CAUSE	SOLUTION
Cabinet does not heat, or doesn't heat properly	<ol style="list-style-type: none"> 1. Fuse 2. Control 3. Sensor 4. Heater contactor 5. Loose wiring at heater contactor 6. On/Off Switch 	<ol style="list-style-type: none"> 1. Replace 2. Replace 3. Replace 4. Replace 5. Replace 6. Replace
Blowers do not operate	<ol style="list-style-type: none"> 1. On/Off Switch 2. Fuse 3. Blower 4. Control 	<ol style="list-style-type: none"> 1. Replace 2. Replace 3. Replace 4. Replace
Heater will not shut off	<ol style="list-style-type: none"> 1. Control defective 	<ol style="list-style-type: none"> 1. Replace
Vent fans do not shut off	<ol style="list-style-type: none"> 1. Vent fan switch defective 2. Control compartment is still hot. 	<ol style="list-style-type: none"> 1. Replace 2. Wait until it cools Check "Heater will not shut off"
Vent fans do not operate (See Note)	<ol style="list-style-type: none"> 1. Fuse 2. Vent fan switch defective 3. Vent fan defective 	<ol style="list-style-type: none"> 1. Replace 2. Replace 3. Replace
Control will not switch from "COOK" to "HOLD" (timed mode)	<ol style="list-style-type: none"> 1. Oven is in "PROBE" mode. 2. Control defective 	<ol style="list-style-type: none"> 1. Switch to "TIMED" mode 2. Replace
Control will not switch from "COOK" to "HOLD" (probe mode)	<ol style="list-style-type: none"> 1. Oven is in the "TIMED" mode 2. Probe not plugged in 3. Control defective 	<ol style="list-style-type: none"> 1. Switch to "PROBE" mode 2. Plug in probe 3. Replace
Control will not switch to "COOK" (probe mode)	<ol style="list-style-type: none"> 1. Oven in "TIMED" mode 2. Probe temperature setting lower than probe temperature 3. Probe not plugged in 4. Control defective 	<ol style="list-style-type: none"> 1. Switch to "PROBE" mode 2. Set probe temperature to desired temperature 3. Plug in probe 4. Replace

NOTE: Vent fans will not operate until the control compartment requires ventilation to limit temperatures. Replacement of electrical components must be done by a qualified electrician.
Refer to our *Service Agency list, FL-1400* (found in the back of this manual), of authorized service centers.
Instructions for replacing parts are included in replacement parts list.

REPLACEMENT PARTS

Include all information on nameplate when ordering parts

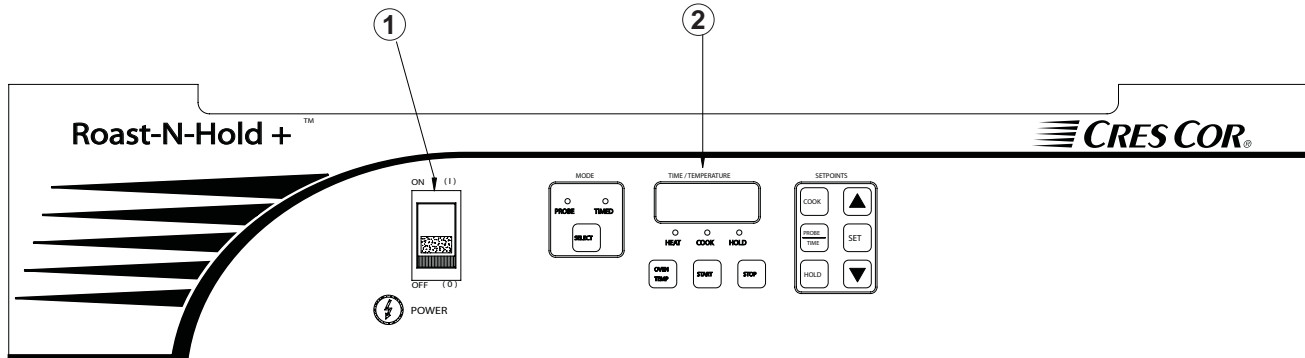

FIGURE 2: CONTROL PANEL

Hot Unit Replacement Parts

ITEM DESCRIPTION	Part No.
1. Switch (On/Off)	0808-113-01-K
2. Thermostat/Timer, Cooking/ Holding	0848-070-02
3. Vent Fan	0769-174
4. Fan Guard	0769-167
5. Fuse (Before 7-08)	0807-058
Fuse (After 7-08)	0807-151
Fuse Holder (Before 7-08)	0807-048
Fuse Holder (After 7-08)	0807-150
8. Terminal Block, front	0852-096
9. Terminal Block, rear	0852-093
10. Switch, Fan	0848-034
11. Hi Limit Switch	0848-079
12. Sensor	0848-073-01
13. Sensor Bushing	0818-014
14. Connector, probe (receptacle)	0848-059-01
Probe 1.5" long	0848-059-02
Probe 6" long	0848-059-04

ITEM DESCRIPTION	Part No.
PARTS for 8200W, 1-PH UNITS	
21. Power Cord	0810-124
Power Cord (Pass-thru)	0810-161
22. Heater Kit, 208V	0811-261
Heater Kit, 240V	0811-262
23. Strain Relief	0818-061
PARTS for 8200W, 3-PH UNITS	
21. Power Cord	0810-132
Power Cord (Pass-thru)	0810-162
22. Heater Kit, 208V	0811-261
Heater Kit, 240V	0811-262
23. Strain Relief	0818-050
PARTS for 4700W, 1-PH UNITS	
21. Power Cord	0810-163
22. Heater Kit, 208V	0811-020-K
Heater Kit, 240V	0811-020-01-K
23. Strain Relief	0818-050
PARTS for 4700W, 3-PH UNITS	
21. Power Cord	0810-164
22. Heater Kit, 208V	0811-020-K
Heater Kit, 240V	0811-020-01-K
23. Strain Relief	0818-050

REPLACEMENT PARTS *(continued)*

FULL SIZE CABINET REPLACEMENT PARTS:

MODEL PREFIX CO-151, RO-151 ("Q" Series)				
DESCRIPTION	-F1332	-FUA (12), (18)	-FPUA (12), (18)	-F1818
Hot Unit, 208V, 1PH	HU675058Q1	HU675017Q1	HU675062Q1	HU675021Q1
Hot Unit, 208V, 3PH	HU675060Q1	HU675018Q1	HU675064Q1	HU675022Q1
Hot Unit, 240V, 1PH	HU675059Q1	HU675019Q1	HU675063Q1	HU675023Q1
Hot Unit, 240V, 3PH	HU675061Q1	HU675020Q1	HU675065Q1	HU675024Q1
Door Latch Kit	1006-120-01-K	1006-120-01-K	1006-120-01-K	1006-120-01-K
Door Strike Kit	1006-120-02-K	1006-120-02-K	1006-120-02-K	1006-120-02-K
Door Hinge	0519-074-K	0519-074-K	0519-074-K	0519-074-K
Door Assembly	1221-543-K	1221-525-K	1221-525-K	1221-541-K
Door Gasket	0861-184	0861-185-K	0861-185-K	0861-197-K
Angles/Racks	1104-108	0621-281-K	0621-281-K	1104-106
Side Handles (2), Black Recessed	0911-102	0911-102	0911-102	0911-102

HALF SIZE CABINET REPLACEMENT PARTS:

MODEL PREFIX CO-151, RO-151 ("Q" Series)				
DESCRIPTION	-HUA6	-H189	-X185	-XUA5
Hot Unit, 208V, 1PH	HU675033Q1	HU675041Q1	HU675033Q1	HU675041Q1
Hot Unit, 208V, 3PH	HU675034Q1	HU675042Q1	HU675034Q1	HU675042Q1
Hot Unit, 240V, 1PH	HU675035Q1	HU675043Q1	HU675035Q1	HU675043Q1
Hot Unit, 240V, 3PH	HU675036Q1	HU675044Q1	HU675036Q1	HU675044Q1
Door Latch Kit	1006-120-01-K	1006-120-01-K	1006-120-01-K	1006-120-01-K
Door Strike Kit	1006-120-02-K	1006-120-02-K	1006-120-02-K	1006-120-02-K
Door Hinge	0519-074-K	0519-074-K	0519-074-K	0519-074-K
Door Assembly	1221-525-K	1221-541-K	1221-546-K	1221-545-K
Door Gasket	0861-185-K	0861-197-K	0861-251	0861-250-K
Angles/Racks	0621-281-K	1104-106	1104-107	0621-281-K

Ovens with Microprocessor Controls	FL-2269
Rev. 10 (6/08)	Page 10 of 13

REPLACEMENT PARTS
for OVENS CO or RO151F SERIES
Include all information on nameplate when ordering parts

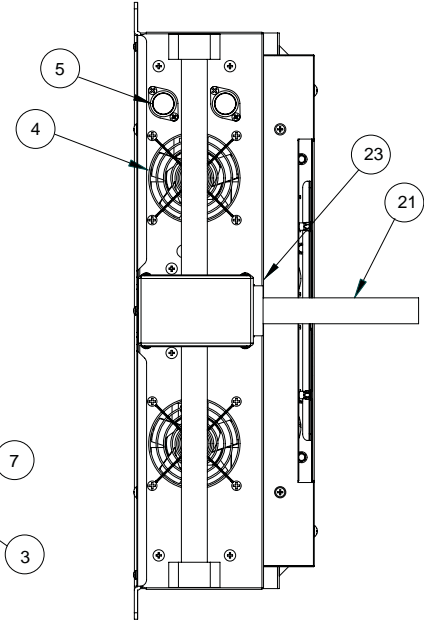
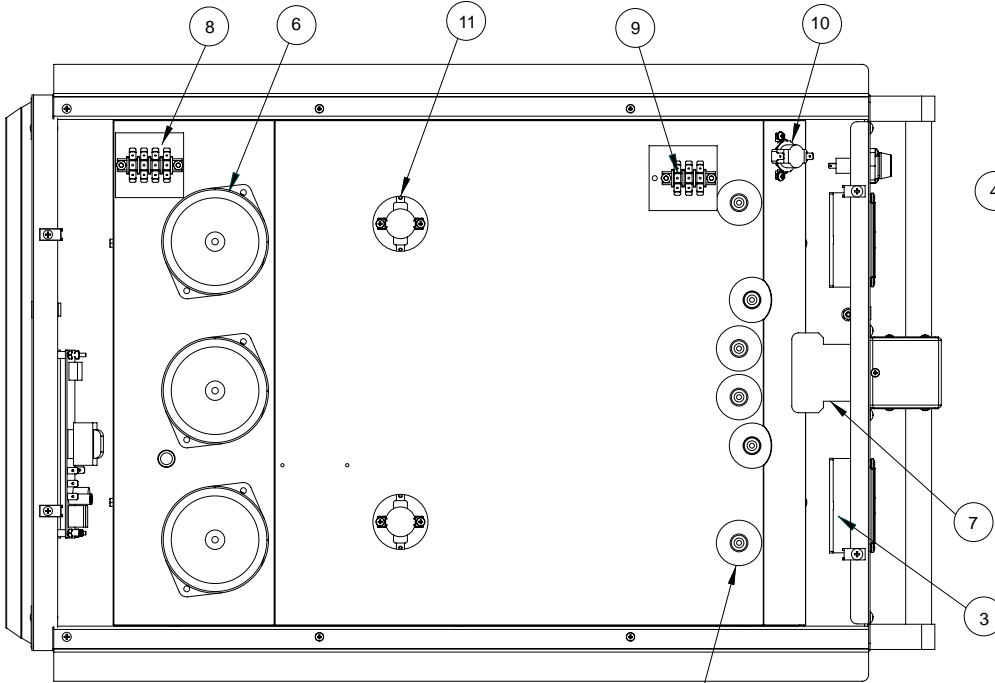

FIGURE 3;
Hot Unit w/o Top cover
(For parts description, refer to page 8.)

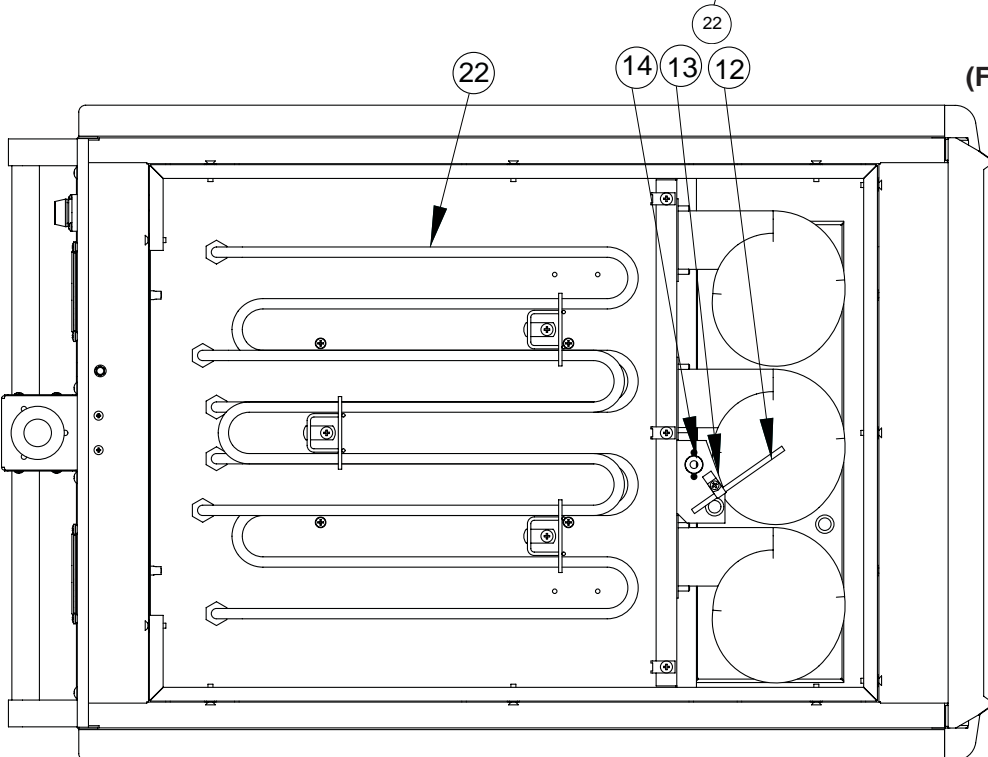

FIGURE 4;
Bottom of Hot Unit, Cover Removed
(For parts description, refer to page 8.)

REPLACEMENT PARTS
for "PASS-THRU" OVENS CO or RO151FPUA SERIES
Include all information on nameplate when ordering parts

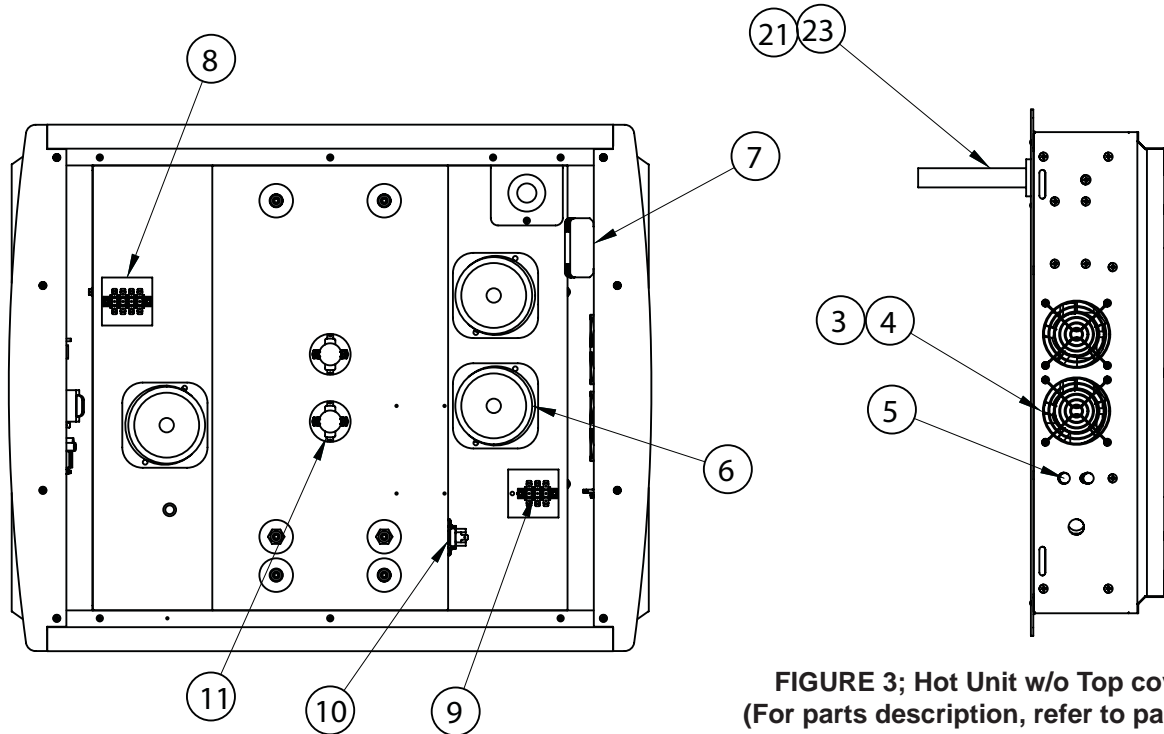
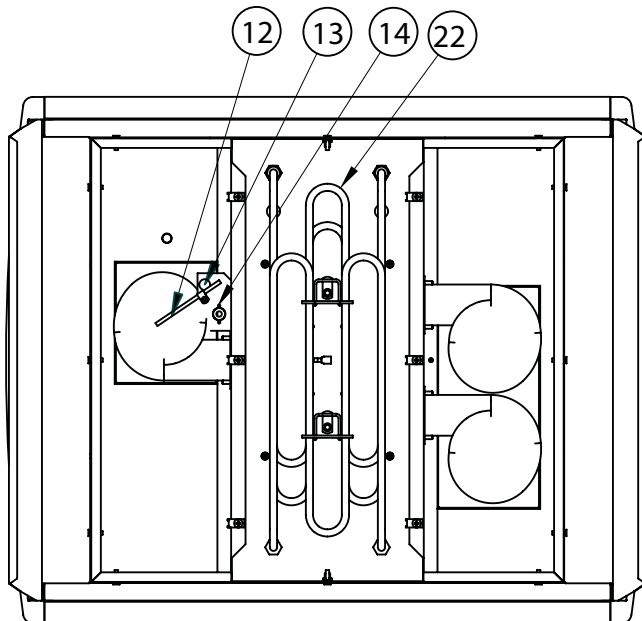
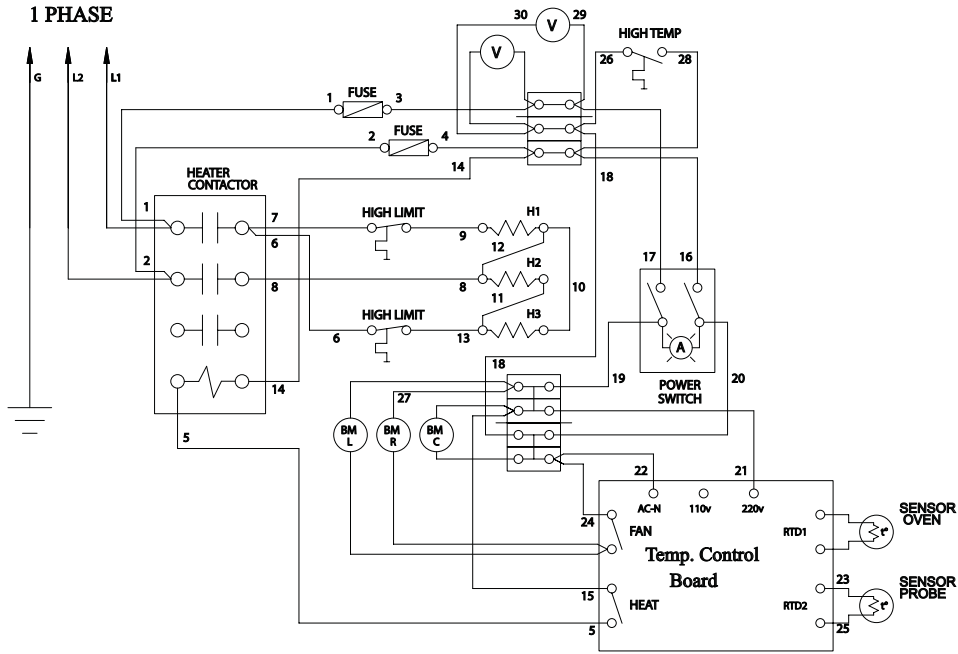

FIGURE 3; Hot Unit w/o Top cover
 (For parts description, refer to page 8.)

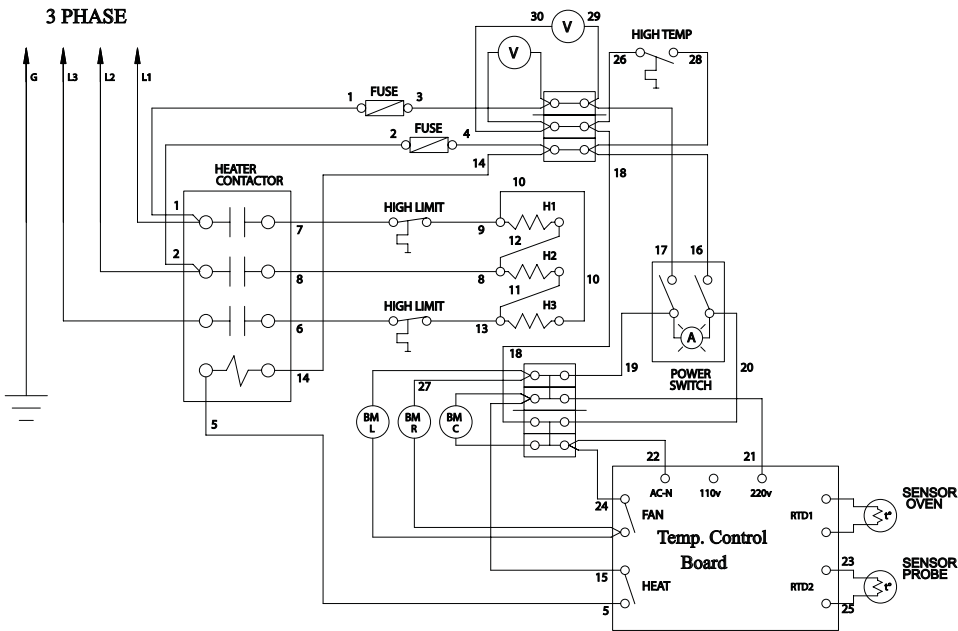

**FIGURE 4; Bottom of Hot Unit, Cover Re-
 moved (For parts description, refer to page 8.)**

WIRING DIAGRAM



SINGLE PHASE



THREE PHASE

OPERATING INSTRUCTIONS FOR OVENS WITH OPTIONAL PRODUCT KEYS

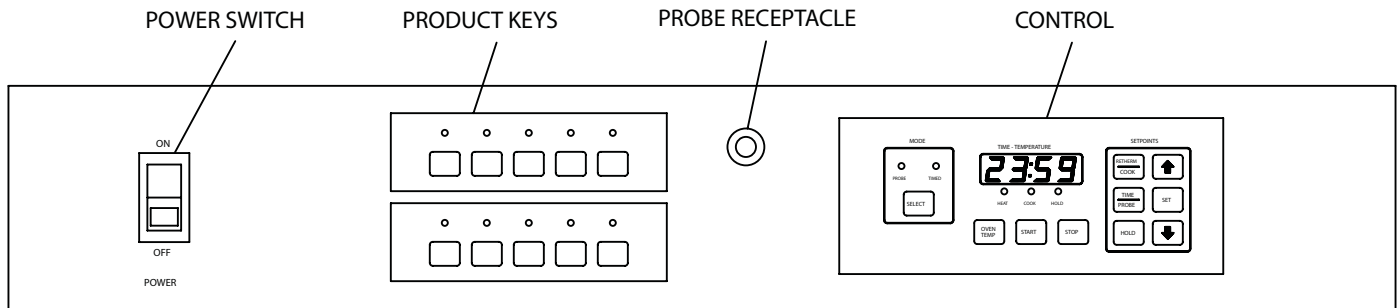

CONTROL PANEL

The Product Keys provide automatic menu selections (arranged in banks of 5 keys, max. 10 keys). Each Product Key can be user programmed for desired mode (PROBE or TIMED) and the required COOK, HOLD, and PROBE or TIME setpoints.

Each Product Key Lights up when pressed “ON”. The Product Key Light will go “OFF” when pressed a second time or when changing any setpoint value. This returns the control to manual operation.

Product Key Programming

1. Press the desired Product Key.
2. Press and hold the SET key until the Product Key light begins to flash.
3. Enter the desired Mode, Cook, Hold and Probe/Time values.

NOTE: Press the SET key after each value is changed or added to accept and store a new setpoint.

4. To exit; Press the SET key for a few seconds until the Product Key light is extinguished.

Extra Replacement Parts:

Product Key (5 Keys) 0848-072

For Hot Unit Replacement, See Page 9:

The Hot Unit suffix number will be Q5 (5 Keys) or Q10 (10 Keys) instead of Q1