

# NordicTrack® *REVITALIZE™* INVERSION SYSTEM

Model No. 30792.0

Serial No. \_\_\_\_\_

Write the serial number in the space above for future reference.

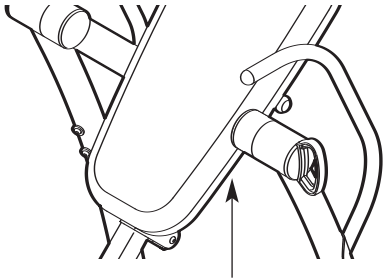

Serial Number Decal (Under Seat)

## USER'S MANUAL

### QUESTIONS?

As a manufacturer, we are committed to providing complete customer satisfaction. If you have questions, or if parts are damaged or missing, PLEASE CONTACT OUR CUSTOMER SERVICE DEPARTMENT DIRECTLY.

CALL TOLL-FREE:

**1-888-936-4266**

Mon.–Fri., 8:00 until 17:00 EST  
(excluding holidays)

OR E-MAIL US:

[customerservice@iconcanada.ca](mailto:customerservice@iconcanada.ca)

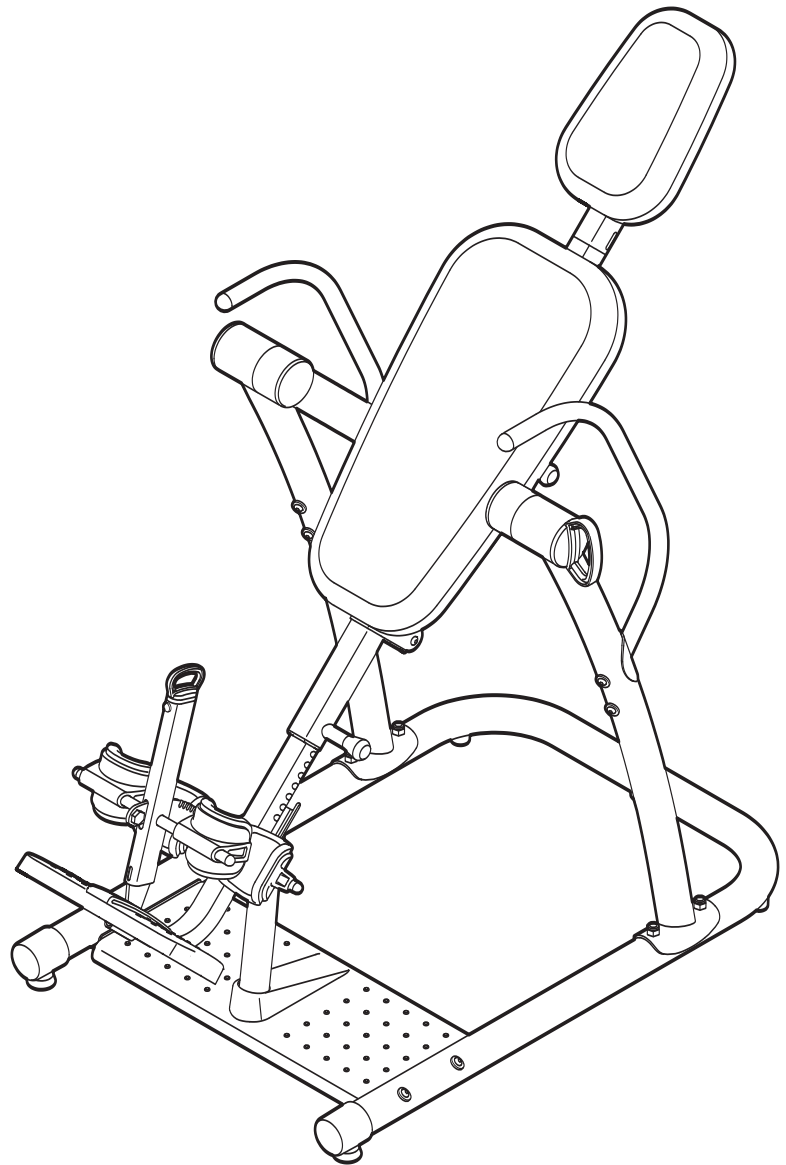

### CAUTION

Read all precautions and instructions in this manual before using this equipment. Save this manual for future reference.



Visit our website at

[www.nordictrack.com](http://www.nordictrack.com)

new products, prizes,  
fitness tips, and much more!

# **NordicTrack**<sup>®</sup> *REVITALIZE*<sup>™</sup> *INVERSION SYSTEM*

---

## **TABLE OF CONTENTS**

|                                       |             |
|---------------------------------------|-------------|
| IMPORTANT PRECAUTIONS .....           | 3           |
| BEFORE YOU BEGIN .....                | 4           |
| PART IDENTIFICATION CHART .....       | 5           |
| ASSEMBLY .....                        | 6           |
| ADJUSTMENT .....                      | 13          |
| ROTATING ON THE INVERSION TABLE ..... | 15          |
| DEVELOPING A PROGRAM .....            | 16          |
| PART LIST .....                       | 18          |
| EXPLODED DRAWING .....                | 19          |
| ORDERING REPLACEMENT PARTS .....      | .Back Cover |
| LIMITED WARRANTY .....                | Back Cover  |

# IMPORTANT PRECAUTIONS

**⚠️ WARNING:** To reduce the risk of serious injury, read the following important precautions before using the inversion table.

1. Read all instructions in this manual before using the inversion table. Use the inversion table only as described in this manual.
2. It is the responsibility of the owner to ensure that all users of the inversion table are adequately informed of all precautions.
3. The inversion table is intended for home use only. Do not use the inversion table in any commercial, rental, or institutional setting.
4. Keep the inversion table indoors, away from moisture and dust. Do not put the inversion table in a garage or covered patio, or near water.
5. Use the inversion table only on a level surface. Cover the floor beneath the inversion table to protect the floor.
6. Make sure that all parts are properly tightened each time the inversion table is used. Replace any worn parts immediately.
7. Keep children under 12 and pets away from the inversion table at all times.
8. The inversion table is designed to support a maximum user weight of 300 lbs. (136 kg). Do not use weights with the inversion table.
9. Always wear athletic shoes with laces to help secure your feet in the inversion table, and for foot protection while exercising.
10. The inversion table should be used only by persons 6 ft. 6 in. (198 cm) tall or less.
11. Keep hands and feet away from moving parts.
12. Always make sure that the ankle lock is secured snugly against your ankles and that the short knob is fully tightened before you use the inversion table.
13. Perform all activities on the inversion table in a slow, controlled manner. Aggressive exercise can cause the inversion table to tip over.
14. Always exercise with a partner. Your partner should be ready to return the backrest to the upright position if you cannot complete the rotation.
15. If you feel pain or dizziness while exercising, stop immediately and begin cooling down.
16. Following is a list of factors and conditions that may make inverting inadvisable (this list is not exhaustive; it is intended only for reference). If one or more factors or conditions apply to you, consult your physician before using the inversion table.
  - Pregnancy
  - Hiatal hernia or ventral hernia
  - Glaucoma, retinal detachment, or conjunctivitis
  - High blood pressure, hypertension, or recent stroke or transient ischemic attack
  - Heart or circulatory disorders for which you are being treated
  - Middle ear infection and extreme obesity
  - Spinal injury, cerebral sclerosis, or acutely swollen joints
  - Bone weakness (osteoporosis), recent unhealed fractures, medullary pins, or surgically implanted orthopedic supports
  - The use of anticoagulants, including high doses of aspirin
17. The decal shown on page 4 has been placed on the inversion table. If the decal is missing or illegible, call the toll-free telephone number on the front cover of this manual and order a free replacement decal. Apply the decal in the location shown.

**⚠️ WARNING:** Before beginning this or any exercise program, consult your physician. This is especially important for persons over the age of 35 or persons with pre-existing health problems. Read all instructions before using. ICON assumes no responsibility for personal injury or property damage sustained by or through the use of this product.

# BEFORE YOU BEGIN

Thank you for selecting the NordicTrack® REVITALIZE™ INVERSION SYSTEM inversion table. The inversion table will increase your intervertebral dimension, decrease pressure on intervertebral discs, stretch and relax your muscles, and temporarily relieve back pain associated with the listed conditions.

**For your benefit, read this manual carefully before using the inversion table.** If you have questions after

reading this manual, please see the front cover of this manual. To help us assist you, note the product model number and serial number before contacting us. The model number is 30792.0. The serial number can be found on a decal attached to the inversion table (see the front cover of this manual).

Before reading further, please review the drawing below and familiarize yourself with the parts that are labeled.

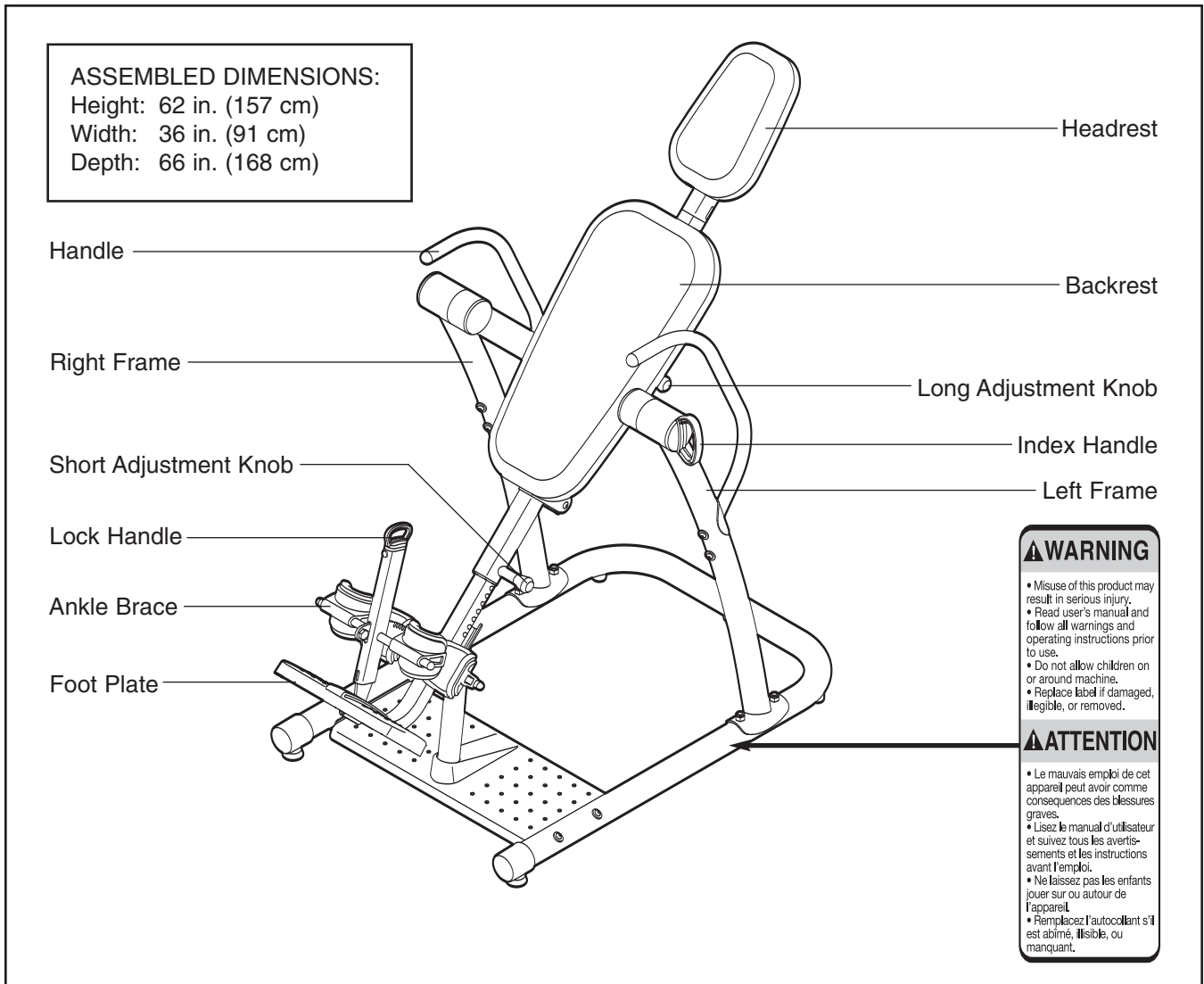

# PART IDENTIFICATION CHART

See the drawings below to identify small parts used in assembly. The number in parentheses by each drawing is the key number of the part, from the PART LIST on page 18. **Note: Some small parts may have been pre-assembled. If a part is not in the parts bag, check to see if it has been preassembled.**

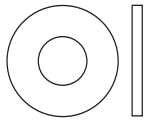

M6 Washer (62)

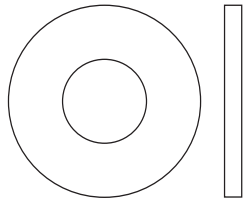

M10 Washer (68)

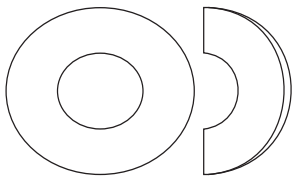

M10 Curved Washer (50)

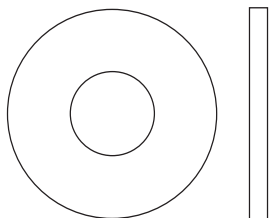

M10 Large Washer (64)



M8 Nylon  
Locknut (72)



M10 Nylon  
Locknut (65)

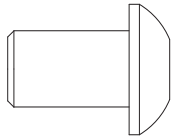

M10 x 16mm  
Button Screw (54)

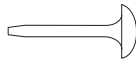

M4 x 15mm  
Screw (58)

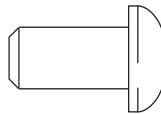

M8 x 16mm  
Button Bolt (61)

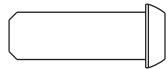

M6 x 18mm  
Button Screw (55)

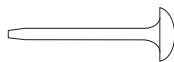

M4 x 20mm  
Screw (71)

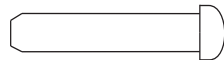

M5 x 25mm  
Screw (59)

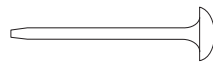

M4 x 25mm  
Screw (60)

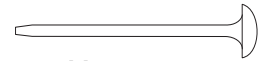

M4 x 30mm  
Screw (63)

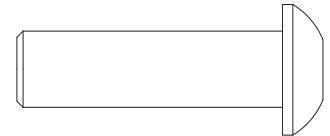

M10 x 35mm  
Button Bolt (53)

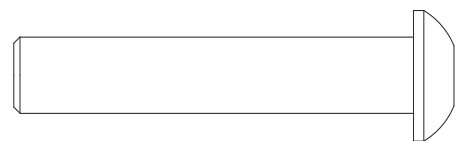

M10 x 53mm Button Bolt (49)

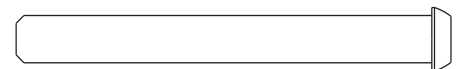

M6 x 55mm Button Screw (56)

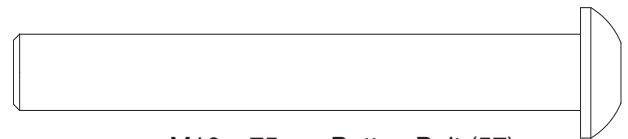

M10 x 75mm Button Bolt (57)

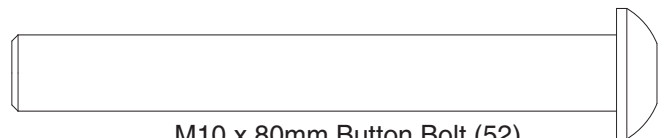

M10 x 80mm Button Bolt (52)

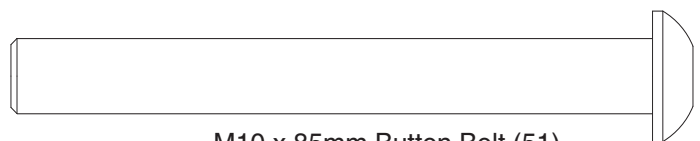

M10 x 85mm Button Bolt (51)

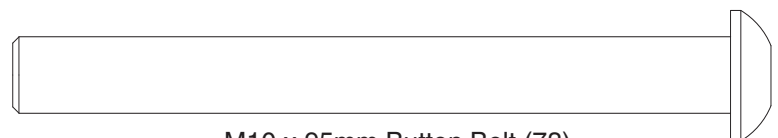

M10 x 95mm Button Bolt (73)

# ASSEMBLY

## Make Assembly Easier





This manual is designed to ensure that the inversion table can be assembled successfully by almost anyone. However, the inversion table has many parts, and the assembly process will take time. Most people find that if they set aside plenty of time, assembly goes smoothly.

**Before beginning assembly, carefully read the following information and instructions:**

- **Assembly requires two persons.**
- Because of its weight and size, the inversion table should be assembled in the location where it will be used. Make sure that there is enough clearance to walk around the inversion table as you assemble it.
- Place all parts in a cleared area and remove the packing materials. Do not dispose of the packing materials until assembly is completed.

- Tighten all parts as you assemble them, unless instructed to do otherwise.
- As you assemble the inversion table, **make sure that all parts are oriented as shown in the drawings.**
- **For help identifying small parts, use the PART IDENTIFICATION CHART on page 5.**

In addition to the included hex key  and grease packets, the following tools (not included) may be required for assembly:

- **two adjustable wrenches** 
- **one rubber mallet** 
- **one standard screwdriver** 
- **one Phillips screwdriver** 

Assembly will be more convenient if you have a socket set, a set of open-end or closed-end wrenches, or a set of ratchet wrenches.

1.

**Before beginning assembly, make sure that you understand the information in the box above. For help identifying small parts, see page 5.**

Attach a Foot (42) to the Left Base (1) with an M4 x 20mm Screw (71). Next, tighten a Leveling Foot (41) into the Left Base (1).

Press a 63mm Round Cap (40) onto the Left Base (1).

**Repeat this step for the Right Base (2).**

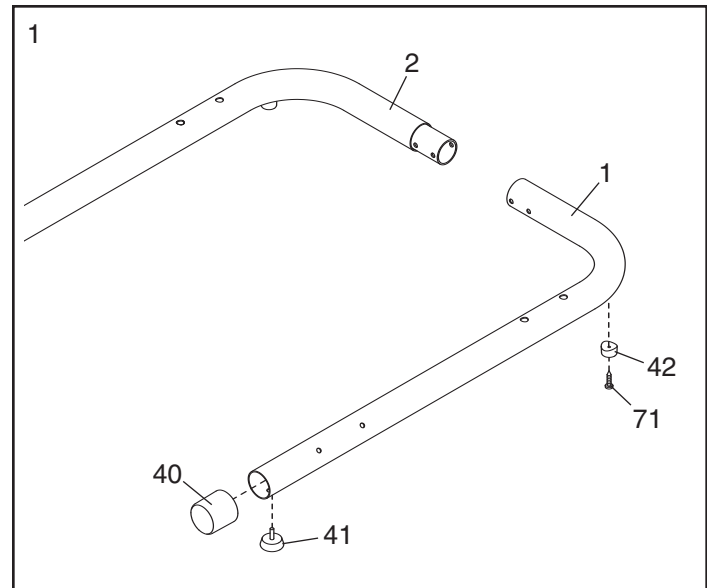

- Attach the Left Base (1) to the Right Base (2) with two M10 x 80mm Button Bolts (52), four M10 Curved Washers (50), and two M10 Nylon Locknuts (65).

Attach another Foot (42) to the Right Base (2) with an M4 x 20mm Screw (71).

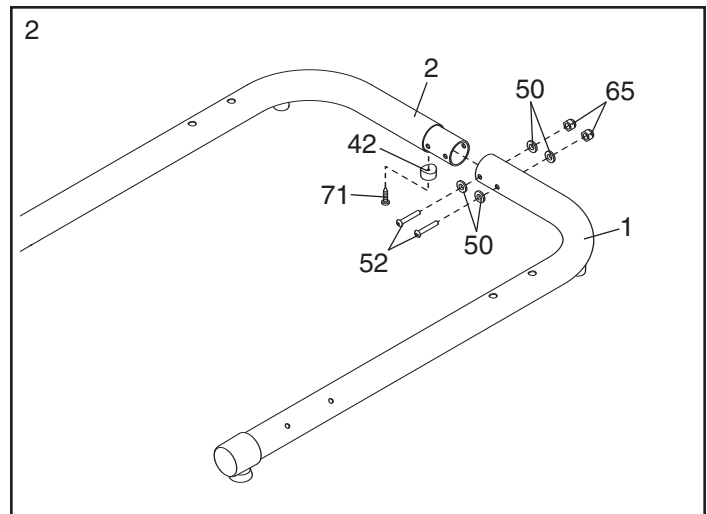

- Attach the Support Leg (13) to the Center Base (3) with three M10 x 35mm Button Bolts (53) and three M10 Nylon Locknuts (65).

Attach the Base Plate (14) to the Center Base (3) with four M5 x 25mm Screws (59).

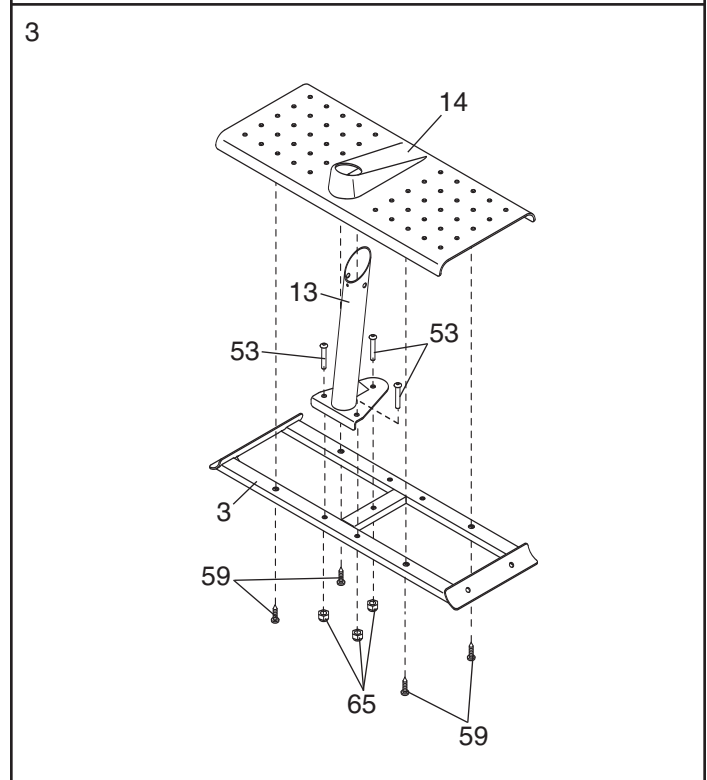

- Attach the Support Bracket (15) to the Support Leg (13) with two M4 x 15mm Screws (58).

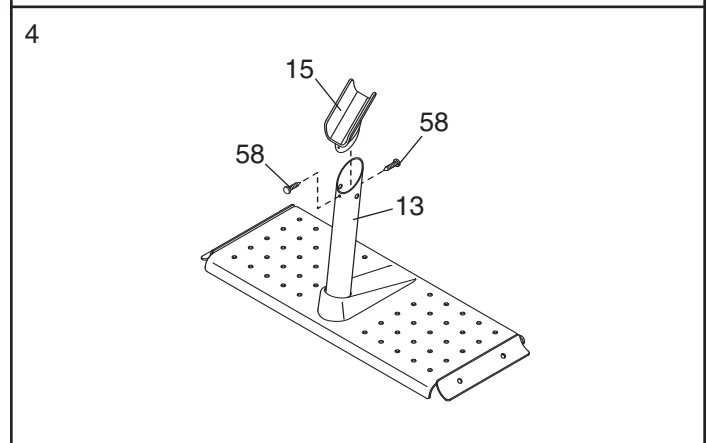

- Attach the Center Base (3) to the Left and Right Bases (1, 2) with four M10 x 80mm Button Bolts (52), four M10 Curved Washers (50), and four M10 Nylon Locknuts (65).

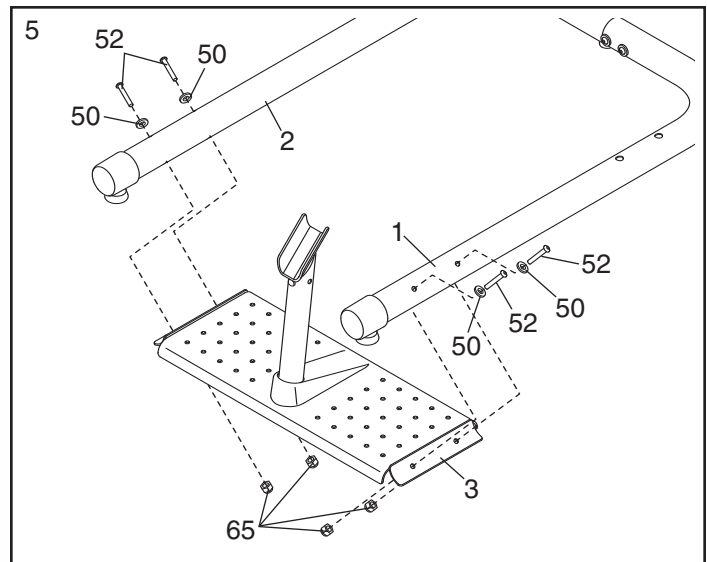

- See the inset drawing.** Identify the Center Frame (7).

Apply some of the included grease to both sides of the Left Large Spacer (31).

Attach the Left Large Spacer (31) and the Left Frame (4) to the Center Frame (7) with an M10 Nylon Locknut (65), an M10 Large Washer (64), and a 29mm Spacer (48). Then, press an 89mm Cap (32) into the Center Frame.

**Repeat this step with the Right Large Spacer (70) and the Right Frame (5).**

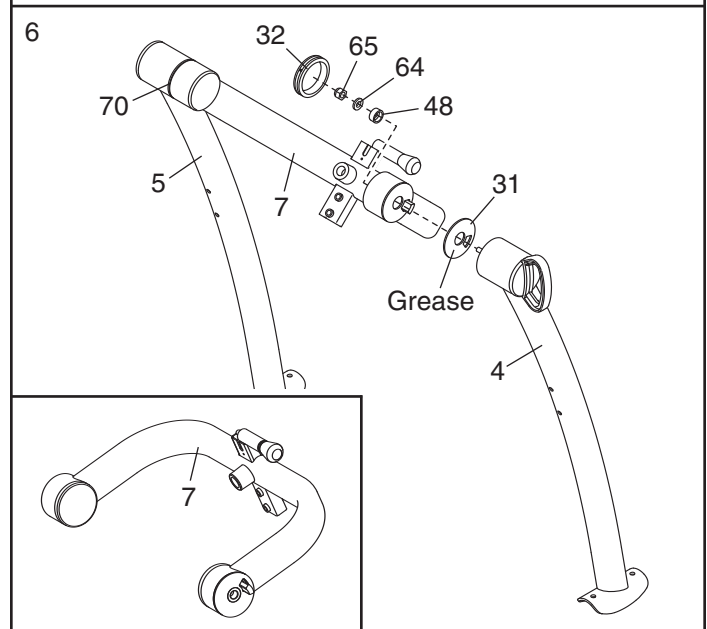

- Attach the Left and Right Frames (4, 5) to the Left and Right Bases (1, 2) with four M10 x 85mm Button Bolts (51) and four M10 Nylon Locknuts (65).

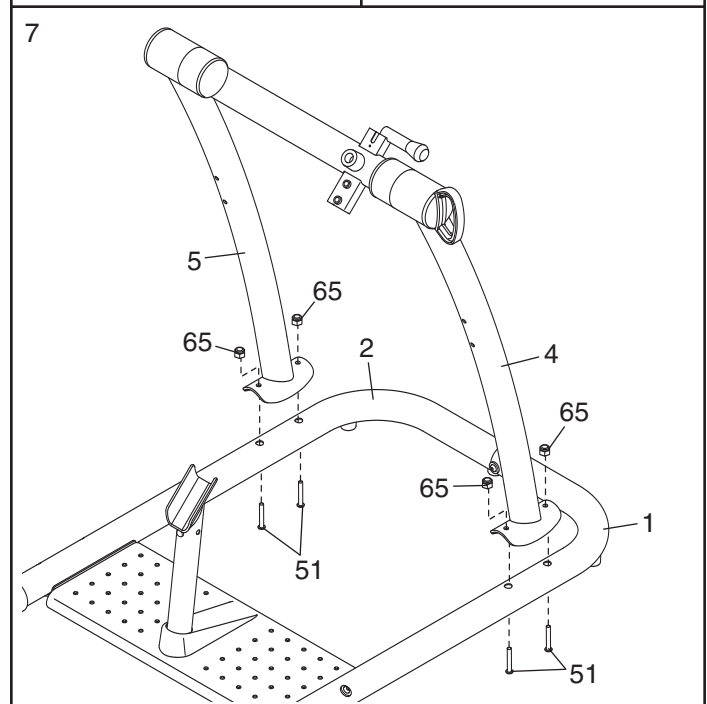



- Attach the Top Cover (23) and the Bottom Cover (24) to the Center Frame (7) with two M4 x 15mm Screws (58) and an M4 x 30mm Screw (63).

Attach the Center Frame Extension (6) to the Center Frame (7) with two M10 x 53mm Button Bolts (49) and two M10 Nylon Locknuts (65).

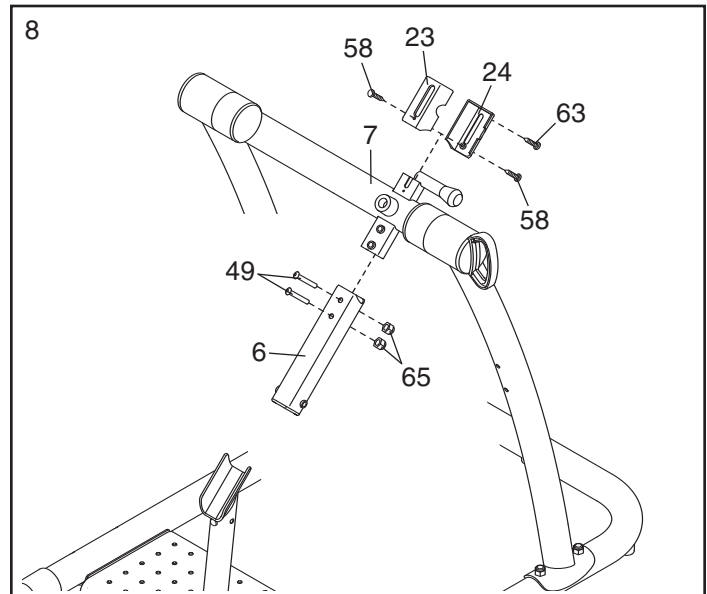

- Orient the Headrest Frame (9) and the Backrest Frame (8) as shown. Attach the Headrest Frame to the Backrest Frame with two M10 x 16mm Button Screws (54).

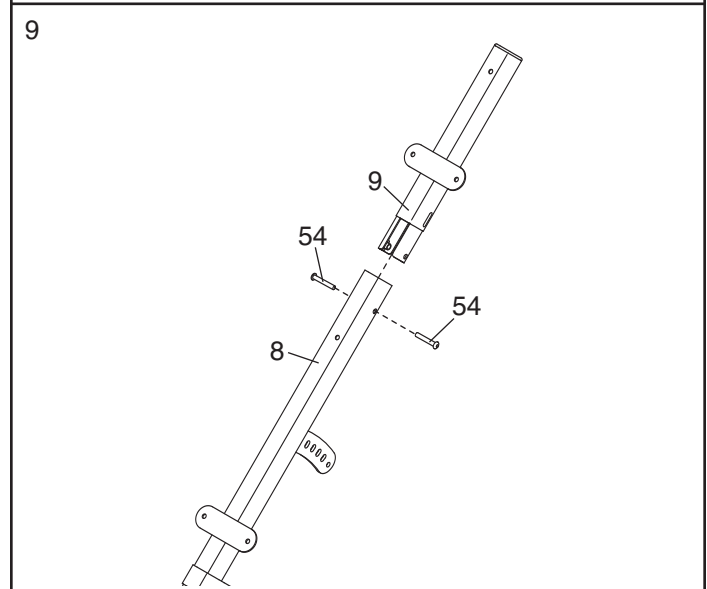

- Apply a small amount of grease to an M10 x 95mm Button Bolt (73).

Pull the Long Adjustment Knob (37) out as far as it will go. Insert the bracket on the Backrest Frame (8) into the Top Cover (23). Next, attach the Backrest Frame to the Center Frame Extension (6) with the M10 x 95mm Button Bolt (73) and an M10 Nylon Locknut (65). Then, engage the Long Adjustment Knob into one of the holes in the bracket.

**See the inset drawing.** Attach an M8 x 16mm Button Bolt (61) and an M8 Nylon Locknut (72) to the hole in the end of the bracket on the Backrest Frame (8).

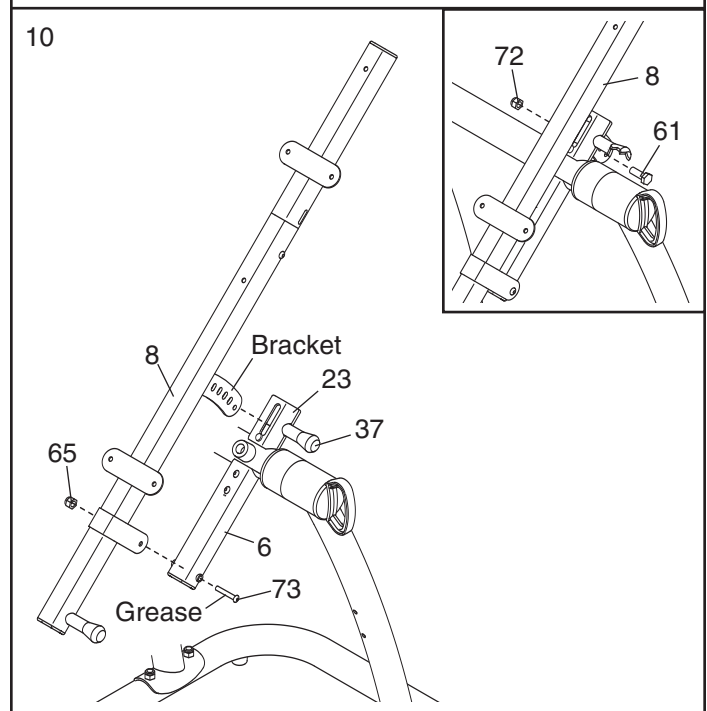

11. **See the left inset drawing.** Identify the Top Tube (16), the Bottom Tube (17), and the Ankle Brace Tube (18); the Tubes have different lengths and holes in different positions.

Orient the Top Tube (16) and the Bottom Tube (17) so that the largest holes are on top (**see the right inset drawing**), and insert them into the indicated holes in the Leg Frame (10). Attach each Tube with an M4 x 15mm Screw (58).

Orient the Ankle Brace Tube (18) as shown, and insert it into the Leg Frame (10). Attach the Ankle Brace Tube with two M4 x 15mm Screws (58).

**Make sure that the M4 x 15mm Screws (58) are tightened into the holes in the bottoms of the Tubes (16, 17, 18).**

12. Set the Foot Plate (19) on the Top Tube (16) and the Bottom Tube (17). **Finger tighten** four M4 x 25mm Screws (60) through the Tubes into the Foot Plate. **Do not tighten the Screws yet.**

13. Slide the Lock Frame (11) onto the notched bracket on the Leg Frame (10), and insert the lower end of the Lock Frame into the slot in the Foot Plate (19). Attach the Lock Frame with an M10 x 75mm Button Bolt (57), two M10 Washers (68), two 16mm Spacers (46), and an M10 Nylon Locknut (65) as shown. **Make sure that the Button Bolt is inserted through the hole in the lower end of the Lock Frame.**

**See step 12. Tighten the four M4 x 25mm Screws (60).**

Pull the Lock Handle (33) upward and pivot the Lock Frame (11) over the indicated notch in the bracket on the Leg Frame (10). Release the Lock Handle and engage the Lock Frame into the notch.

**See the inset drawing.** Attach an M8 x 16mm Button Bolt (61) and an M8 Nylon Locknut (72) to the hole in the end of the bracket on the Leg Frame (10).

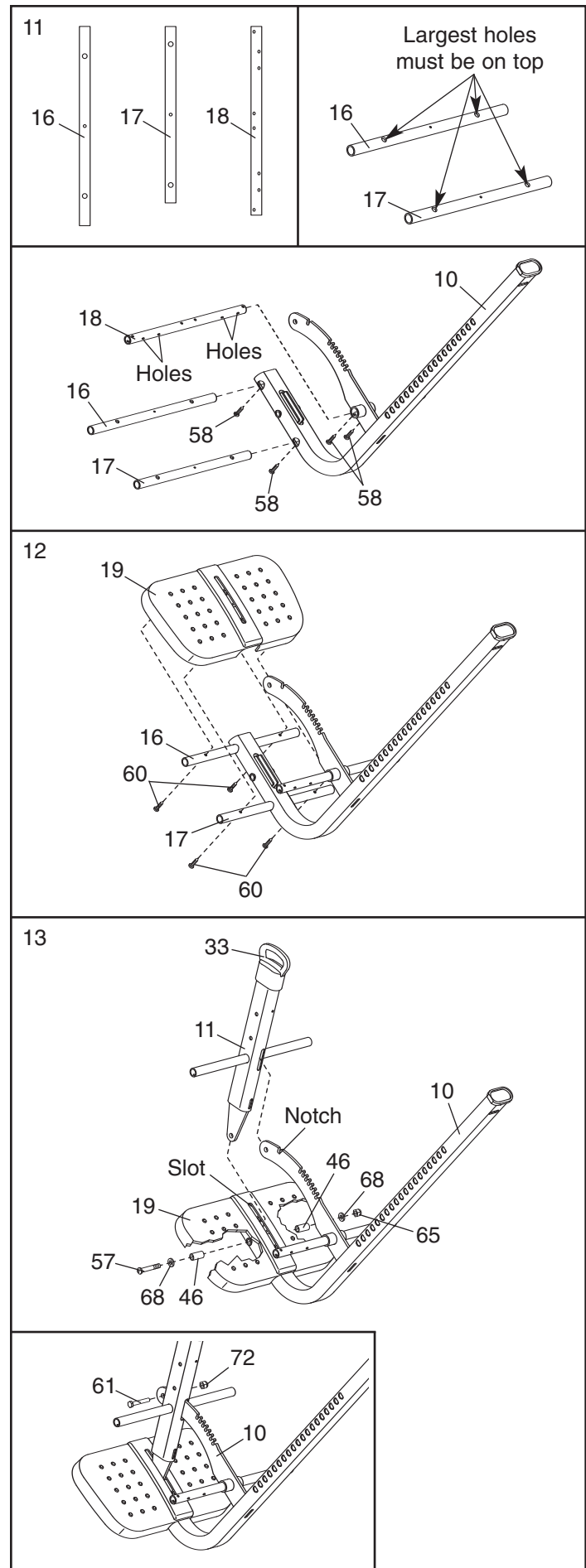

14. Identify the two Rear Ankle Braces (34), which have holes in the indicated locations.

Slide a Rear Ankle Brace (34) onto the Ankle Brace Tube (18). Attach the Rear Ankle Brace with two M4 x 15mm Screws (58). **Make sure that the Screws are tightened into the indicated holes in the Ankle Brace Tube.** Next, press a 19mm Round Cap (45) into the Ankle Brace Tube, and attach the Round Cap with an M4 x 15mm Screw (58).

**Attach the other Rear Ankle Brace (34) to the Ankle Brace Tube (18) in the same way.**

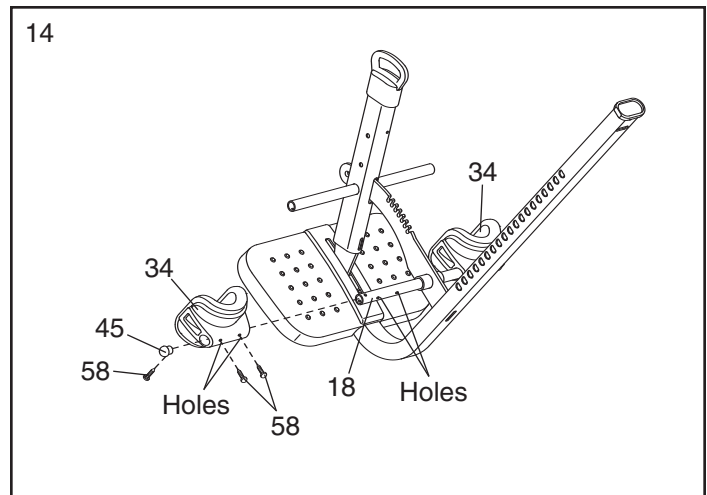

15. Slide a Front Ankle Brace (22) onto the round tube on the Lock Frame (11). Next, press a 19mm Round Cap (45) into the round tube, and attach the Round Cap with an M4 x 15mm Screw (58).

**Attach the other Front Ankle Brace (22) in the same way.**

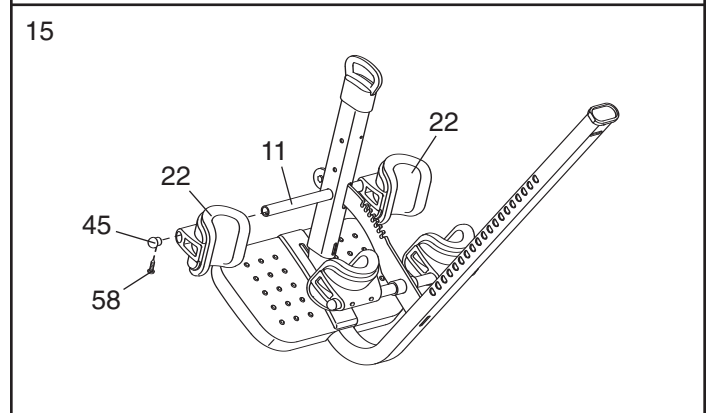

16. Pull the Short Adjustment Knob (74) out as far as it will go, and insert the end of the Leg Frame (10) a few inches into the Backrest Frame (8).

**See the inset drawing.** Press the round tab on the Leg Frame Bushing (38), and press the Leg Frame Bushing upward into the Backrest Frame (8). **Make sure that the round tab is in the indicated hole in the Backrest Frame.**

Then, slide the Leg Frame (10) farther into the Backrest Frame (8), and engage the Short Adjustment Knob (74) into one of the holes in the Leg Frame.

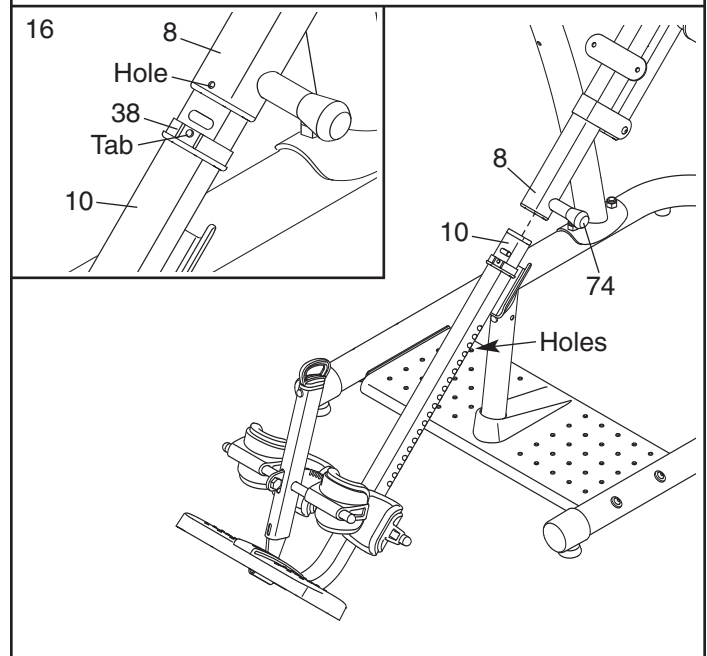

17. Attach the Headrest (20) to the Headrest Frame (9) with two M6 x 18mm Button Screws (55), an M6 x 55mm Button Screw (56), and three M6 Washers (62).

Attach the Backrest (21) to the Backrest Frame (8) in the same way.

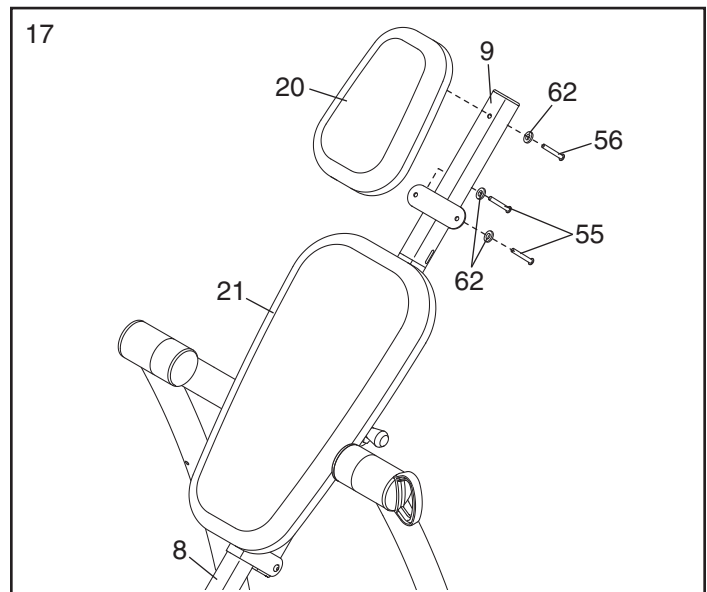

18. Attach a Handle (12) to the Left Frame (4) with two M10 x 80mm Button Bolts (52), two M10 Curved Washers (50), and two M10 Nylon Locknuts (65).

Attach the other Handle (12) in the same way.

Make sure that all parts are properly tightened before you use the inversion table.

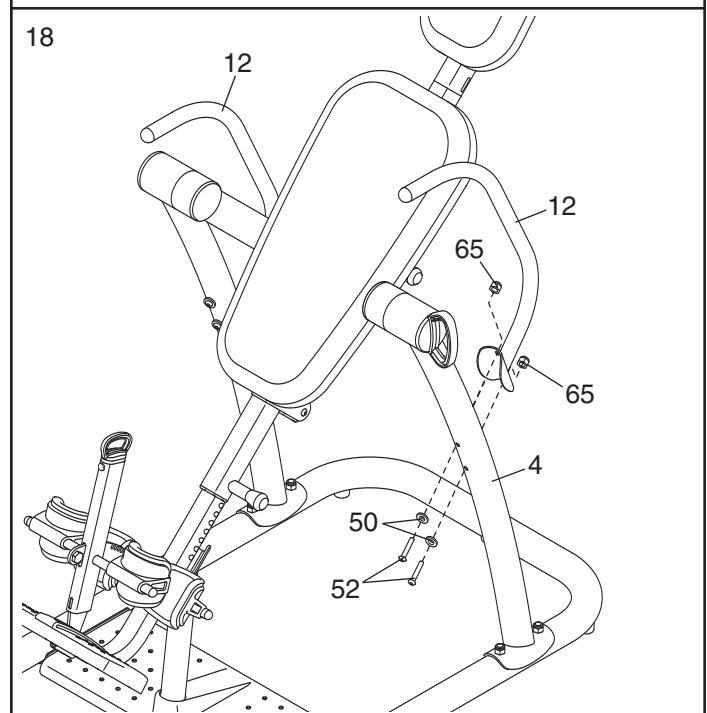

## **⚠ WARNING:**

### **HOW TO LOCK THE INVERSION TABLE FOR STORE DISPLAY OR TO PREVENT UNSUPERVISED USE**

When the inversion table is displayed in a store, or when it is not in use, it should be locked to prevent unsupervised use. First, insert the threaded end of the Lock Pin (35) into the Support Leg (13), and position the other end of the Lock Pin on top of the Leg Frame (10). Then, tighten an M10 Nylon Locknut (65) onto the Lock Pin.

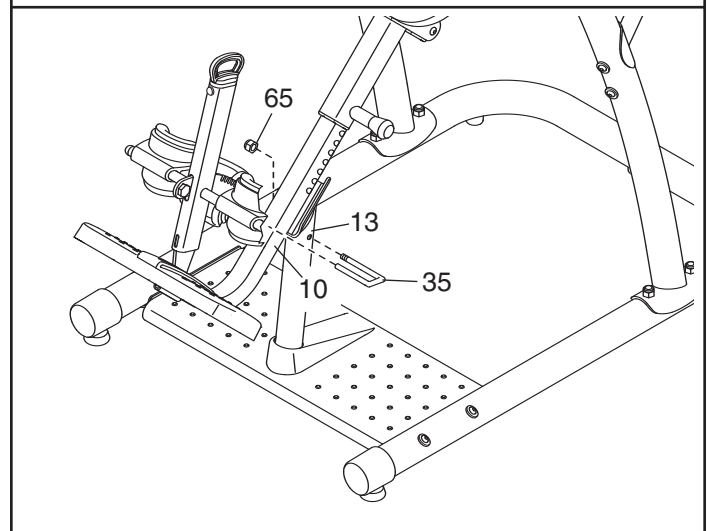

# ADJUSTMENT

This section explains how to adjust the inversion table. See DEVELOPING A PROGRAM on page 16 for important information about how to get the most benefit from the inversion table.

Make sure that all parts are properly tightened each time you use the inversion table. Replace any worn parts immediately. The inversion table can be cleaned with a damp cloth and a mild, non-abrasive detergent. **Do not use solvents to clean the inversion table.**

## SELECTING THE BACKREST FRAME POSITION

See the inset drawing. The bracket on the Backrest Frame (8) has four adjustment holes. The correct hole to use will depend on your body weight and the desired level of responsiveness. See the chart to determine which hole to use. For example, if you weigh between 200 and 250 pounds and you are a beginning user, the chart recommends that you use hole A.

To adjust the Backrest Frame (8), first pull the Long Adjustment Knob (37) out as far as it will go. Move the Backrest Frame and engage the Long Adjustment Knob into the desired hole in the bracket on the Backrest Frame.

Try the inversion table with the Backrest Frame (8) adjusted to each position to determine which one is best for you.

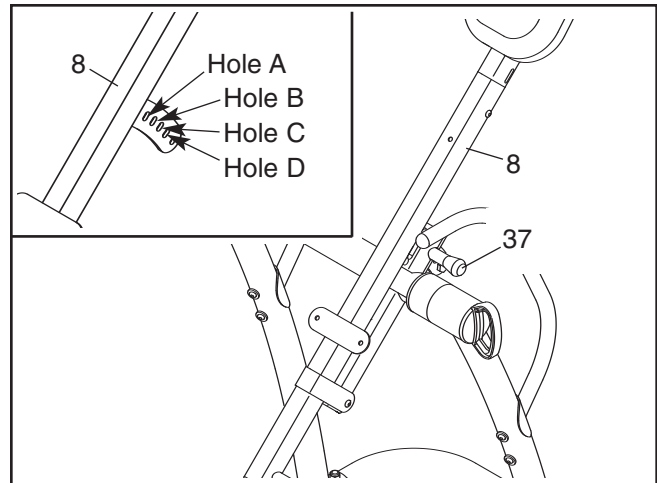

|                      |              | Responsiveness               |                           |
|----------------------|--------------|------------------------------|---------------------------|
|                      |              | Beginner (Partial Inversion) | Advanced (Full Inversion) |
| Note: 1 lb. = 2.2 kg |              |                              |                           |
| User Weight          | 250–300 lbs. | Hole A                       | Hole B                    |
|                      | 200–250 lbs. | Hole A                       | Hole B                    |
|                      | 150–200 lbs. | Hole B                       | Hole C                    |
|                      | 80–150 lbs.  | Hole C                       | Hole D                    |

## ADJUSTING THE LEG FRAME

The length of the Leg Frame (10) can be adjusted to correspond to your height. Pull the Short Adjustment Knob (74) out as far as it will go. Slide the Leg Frame into or out of the Backrest Frame (8) so that the first or second measurement greater than your height is covered by the Backrest Frame. Then, engage the Short Adjustment Knob into adjustment holes in the Leg Frame and the Backrest Frame.

Use the inversion table with the Leg Frame (10) adjusted to a few different lengths to determine which length is best for you.

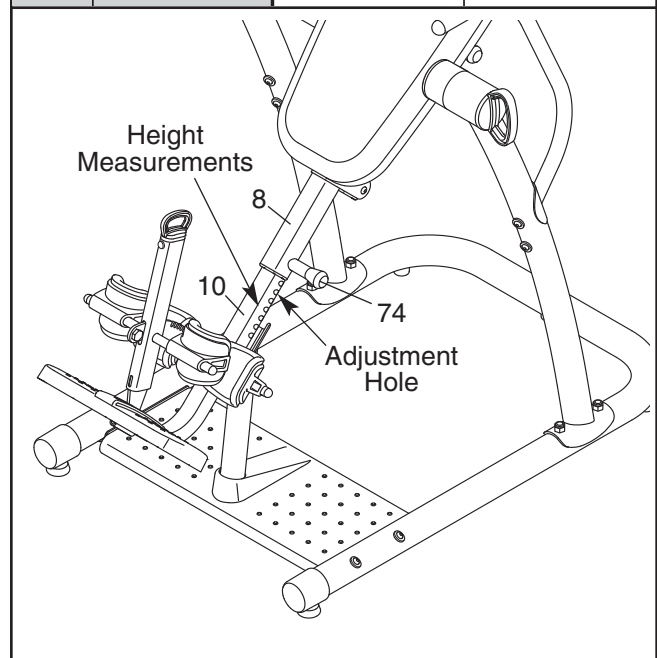

**WARNING:** The inversion table is designed to be used by persons 6 ft. 6 in. (198 cm) tall or less.

## USING THE ANKLE LOCK

To secure your ankles in the inversion table, pull the Lock Handle (33) out as far as it will go, and move the Lock Frame (11) away from the Leg Frame (10). Stand on the Foot Plate (19), with the backs of your legs against the Rear Ankle Braces (34). Then, push the Lock Frame against your ankles and engage the Lock Handle into a notch in the Leg Frame.

**⚠ WARNING:** Always make sure that the Lock Frame (11) is secured snugly against your ankles before using the inversion table. Always wear athletic shoes with laces to help secure your feet in the inversion table.

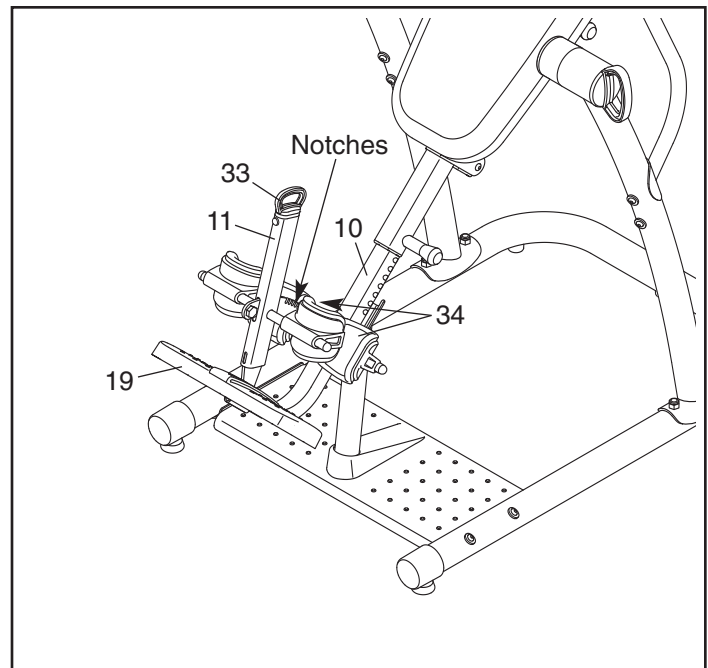

## SETTING THE INVERSION ANGLE

The inversion table can be set to rotate between 15° and 90°, in 15° increments. To set the inversion angle, pull the Index Handle (25) out as far as it will go, and turn the Index Handle until the arrow on top of the Index Handle points to the desired degree setting. Then, release the Index Handle; **make sure that the Index Handle is fully engaged.**

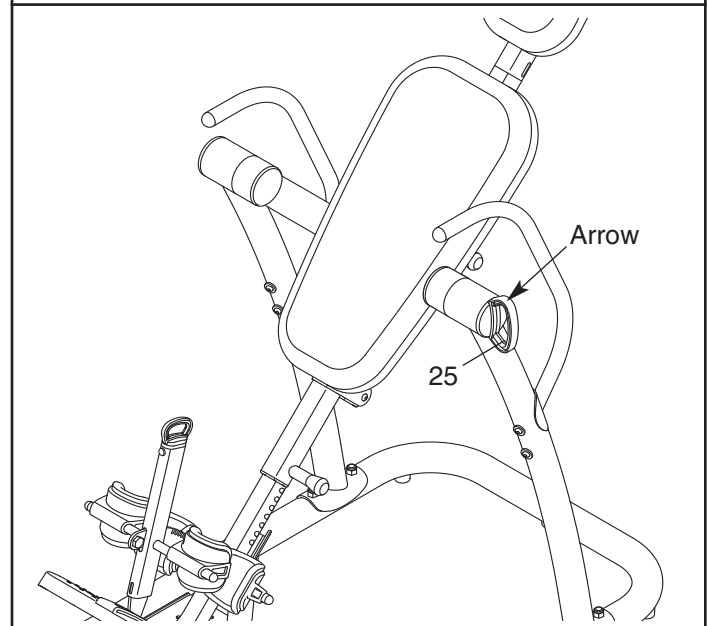

## LEVELING THE INVERSION TABLE

If the inversion table rocks slightly on your floor, turn one or both of the Leveling Feet (41) until the inversion table is level.

## LOCKING THE INVERSION TABLE

To lock the inversion table when you are not using it, insert the threaded end of the Lock Pin (35) into the Support Leg (13), and position the other end of the Lock Pin on top of the Leg Frame (10). Then, tighten an M10 Nylon Locknut (65) onto the Lock Pin.

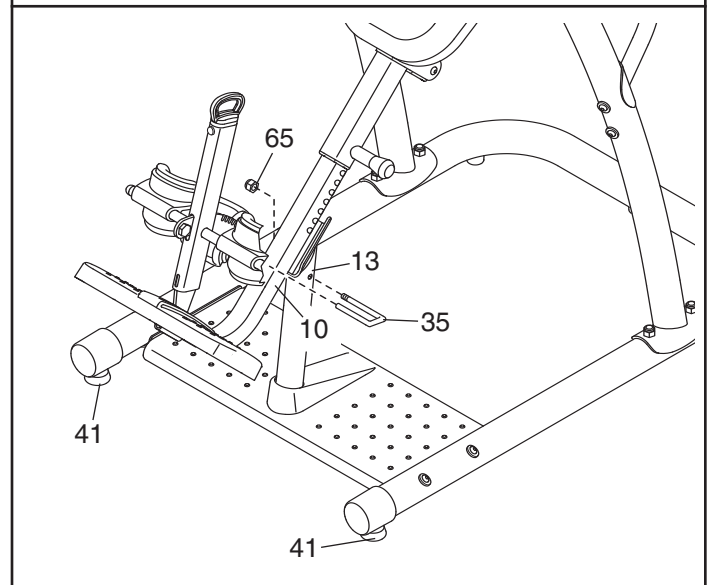

---

# ROTATING ON THE INVERSION TABLE

This section explains how to rotate back on the inversion table, and then return to the starting position. **Before using the inversion table, see the ADJUSTMENT section starting on page 13 to correctly set up the inversion table.** It may be helpful to have a second person ready to assist you as you learn to use the inversion table.

## ROTATING BACK ON THE INVERSION TABLE

To rotate back on the inversion table, slowly lift your arms over your head until you reach the desired position. The speed at which you lift your arms will determine how quickly the inversion table will rotate. Rest your arms in a comfortable position that does not cause the inversion table to rotate. Note: The inversion table will rotate only to the degree setting set by the index handle.

## ROTATING UP ON THE INVERSION TABLE

To return to the starting position, move your hands toward your waist until you rotate to a horizontal position. Rest in a horizontal position for 30 to 60 seconds before rotating to the starting position. This will allow your body to readjust. Return to the starting position slowly. Dizziness after using the inversion table is an indication that you have returned to the starting position too quickly.

To rotate up from the fully inverted position, pull yourself up using the handles.

**Do not sit up to return to the starting position.**

---

# DEVELOPING A PROGRAM

This section contains information and suggestions about using the inversion table. Make sure that all parts are properly tightened each time you use the inversion table. Replace any worn parts immediately. **See the ADJUSTMENT section starting on page 13 to identify parts referred to in this section.**

## **BENEFITING FROM USING THE INVERSION TABLE INTERMEDIATE PROGRAM**

If you feel nauseated while using the inversion table, return to the starting position. Note that it may take a few weeks of use for your inner ear to become accustomed to being inverted.

Do not use the inversion table right after you have eaten.

Moving while using the inversion table may make it a more comfortable experience, and may help joints and muscles stretch and relax. Always move in a slow, controlled manner.

The greater the angle at which the inversion table is used, the shorter the time that you should rotate back before rotating up. Increase the amount of inverted time and the angle of use gradually.

Always pay attention to how your body feels as you use the inversion table. Increase the level of intensity only as it is comfortable for you. When you feel like you have had enough, return to the starting position.

### **BEGINNER PROGRAM**

The following are suggestions for persons who are just starting to use the inversion table.

Set the index handle to allow the backrest frame to rotate to 15° or less for the first one or two weeks. This will allow your body time to adjust to the change in gravitational pull.

Use the inversion table for one or two minutes at a time, two or three times a day.

Stay inverted only for as long as it is comfortable. This may be only a few seconds at first.

The following are suggestions for persons who have become comfortable using the inversion table as described under the BEGINNER PROGRAM.

Increase the angle to which the inversion table can rotate, as it is comfortable. Adjust the index handle to allow the inversion table to rotate to up to 60°, a few degrees at a time.

Start to do gentle stretching while using the inversion table.

Gradually increase the amount of time that you use the inversion table to ten minutes or more, two or three times a day. Routines can be varied from rotating back for one or two minutes and then up for 30 seconds, to rotating back and up for equal amounts of time.

### **FULL INVERSION PROGRAM**

The following are suggestions for persons who have become comfortable using the inversion table as described under the INTERMEDIATE PROGRAM and desire to rotate to greater angles. Note that all the benefits of inversion can be gained by rotating to 60°. **Do not attempt to do sit-ups.**

Increase the angle to which the inversion table can rotate, as it is comfortable. Adjust the index handle to allow the inversion table to rotate until it comes in contact with the center frame.

Adjust the backrest frame so that the long adjustment knob is in the top hole (see SELECTING THE BACKREST FRAME POSITION on page 13). If you weigh 220 lbs. (100 kg) or more, adjust the long adjustment knob to the center hole in the backrest frame. Rotate back and up as described on page 15.



---

# NOTES

# PART LIST—Model No. 30792.0

R0107A

| Key No. | Qty. | Description            | Key No. | Qty. | Description             |
|---------|------|------------------------|---------|------|-------------------------|
| 1       | 1    | Left Base              | 40      | 2    | 63mm Round Cap          |
| 2       | 1    | Right Base             | 41      | 2    | Leveling Foot           |
| 3       | 1    | Center Base            | 42      | 3    | Foot                    |
| 4       | 1    | Left Frame             | 43      | 1    | M6 Nut                  |
| 5       | 1    | Right Frame            | 44      | 2    | 32mm Round Cap          |
| 6       | 1    | Center Frame Extension | 45      | 4    | 19mm Round Cap          |
| 7       | 1    | Center Frame           | 46      | 2    | 16mm Spacer             |
| 8       | 1    | Backrest Frame         | 47      | 2    | Pivot Bushing           |
| 9       | 1    | Headrest Frame         | 48      | 2    | 29mm Spacer             |
| 10      | 1    | Leg Frame              | 49      | 2    | M10 x 53mm Button Bolt  |
| 11      | 1    | Lock Frame             | 50      | 12   | M10 Curved Washer       |
| 12      | 2    | Handle                 | 51      | 4    | M10 x 85mm Button Bolt  |
| 13      | 1    | Support Leg            | 52      | 10   | M10 x 80mm Button Bolt  |
| 14      | 1    | Base                   | 53      | 3    | M10 x 35mm Button Bolt  |
| 15      | 1    | Support Bracket        | 54      | 2    | M10 x 16mm Button Screw |
| 16      | 1    | Top Tube               | 55      | 4    | M6 x 18mm Button Screw  |
| 17      | 1    | Bottom Tube            | 56      | 2    | M6 x 55mm Button Screw  |
| 18      | 1    | Ankle Brace Tube       | 57      | 1    | M10 x 75mm Button Bolt  |
| 19      | 1    | Foot Plate             | 58      | 20   | M4 x 15mm Screw         |
| 20      | 1    | Headrest               | 59      | 4    | M5 x 25mm Screw         |
| 21      | 1    | Backrest               | 60      | 4    | M4 x 25mm Screw         |
| 22      | 2    | Front Ankle Brace      | 61      | 2    | M8 x 16mm Button Bolt   |
| 23      | 1    | Top Cover              | 62      | 7    | M6 Washer               |
| 24      | 1    | Bottom Cover           | 63      | 1    | M4 x 30mm Screw         |
| 25      | 1    | Index Handle           | 64      | 2    | M10 Large Washer        |
| 26      | 1    | Index Ring             | 65      | 24   | M10 Nylon Locknut       |
| 27      | 1    | Cup Washer             | 66      | 1    | M6 x 15mm Screw         |
| 28      | 1    | Small Spring           | 67      | 2    | M5 x 15mm Screw         |
| 29      | 1    | Cup Bushing            | 68      | 2    | M10 Washer              |
| 30      | 1    | Index Cup              | 69      | 1    | 30mm x 60mm Cap         |
| 31      | 1    | Left Large Spacer      | 70      | 1    | Right Large Spacer      |
| 32      | 3    | 89mm Cap               | 71      | 3    | M4 x 20mm Screw         |
| 33      | 1    | Ankle Lock Assembly    | 72      | 2    | M8 Nylon Locknut        |
| 34      | 2    | Rear Ankle Brace       | 73      | 1    | M10 x 95mm Button Bolt  |
| 35      | 1    | Lock Pin               | 74      | 1    | Short Adjustment Knob   |
| 36      | 1    | Bumper                 | 75      | 1    | M6 x 60mm Button Bolt   |
| 37      | 1    | Long Adjustment Knob   | #       | -    | User's Manual           |
| 38      | 1    | Leg Frame Bushing      | #       | -    | Hex Key                 |
| 39      | 2    | 42mm x 70mm Cap        | #       | -    | Grease Packet           |

Note: “#” indicates a non-illustrated part. Specifications are subject to change without notice. See the back cover of this manual for information about ordering replacement parts.

# EXPLODED DRAWING—Model No. 30792.0

R0107A

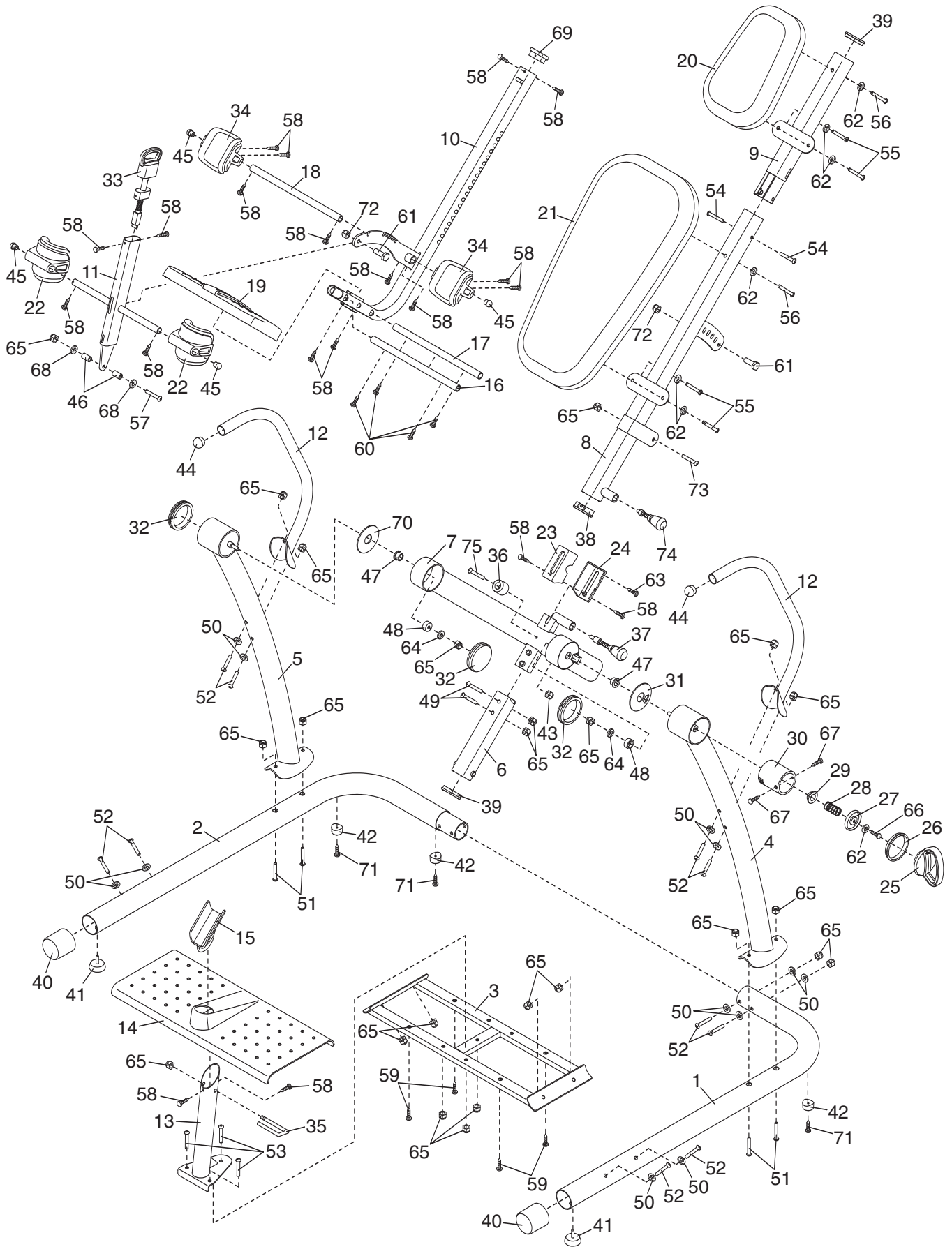

---

## ORDERING REPLACEMENT PARTS

To order replacement parts, please see the front cover of this manual. To help us assist you, be prepared to provide the following information when contacting us:

- the MODEL NUMBER of the product (30792.0)
- the NAME of the product (NordicTrack REVITALIZE INVERSION SYSTEM inversion table)
- the SERIAL NUMBER of the product (see the front cover of this manual)
- the KEY NUMBER and DESCRIPTION of the part(s) (see the PART LIST and the EXPLODED DRAWING on pages 18 and 19)

---

## LIMITED WARRANTY

ICON of Canada, Inc. (ICON) warrants this product to be free from defects in workmanship and material, under normal use and service conditions. The frame is warranted for five (5) years after the date of purchase. ICON warrants all other parts and labor for one (1) year. This warranty extends only to the original purchaser. ICON's obligation under this warranty is limited to replacing or repairing, at ICON's option, the product through one of its authorized service centers. All repairs for which warranty claims are made must be pre-authorized by ICON. This warranty does not extend to any product or damage to a product caused by or attributable to freight damage, abuse, misuse, improper or abnormal usage or repairs not provided by an ICON authorized service center; products used for commercial or rental purposes; or products used as store display models. No other warranty beyond that specifically set forth above is authorized by ICON.

ICON is not responsible or liable for indirect, special or consequential damages arising out of or in connection with the use or performance of the product or damages with respect to any economic loss, loss of property, loss of revenues or profits, loss of enjoyment or use, costs of removal or installation or other consequential damages of whatsoever nature. Some provinces do not allow the exclusion or limitation of incidental or consequential damages. Accordingly, the above limitation may not apply to you. The warranty extended hereunder is in lieu of any and all other warranties and any implied warranties of merchantability or fitness for a particular purpose is limited in its scope and duration to the terms set forth herein. Some provinces do not allow limitations on how long an implied warranty lasts. Accordingly, the above limitation may not apply to you.

This warranty gives you specific legal rights. You may also have other rights which vary from province to province.

**ICON of Canada, Inc., 900 de l'Industrie, St. Jérôme, QC J7Y 4B8**