

SONY.

VAIO Digital Studio™ Reference Manual

PCV-R532DS



Notice to Users

© 1999 Sony Electronics Inc. All rights reserved. This manual and the software described herein, in whole or in part, may not be reproduced, translated, or reduced to any machine-readable form without prior written approval.

SONY ELECTRONICS INC. PROVIDES NO WARRANTY WITH REGARD TO THIS MANUAL, THE SOFTWARE, OR OTHER INFORMATION CONTAINED HEREIN AND HEREBY EXPRESSLY DISCLAIMS ANY IMPLIED WARRANTIES OF MERCHANTABILITY OR FITNESS FOR ANY PARTICULAR PURPOSE WITH REGARD TO THIS MANUAL, THE SOFTWARE, OR SUCH OTHER INFORMATION. IN NO EVENT SHALL SONY ELECTRONICS INC. BE LIABLE FOR ANY INCIDENTAL, CONSEQUENTIAL, OR SPECIAL DAMAGES, WHETHER BASED ON TORT, CONTRACT, OR OTHERWISE, ARISING OUT OF OR IN CONNECTION WITH THIS MANUAL, THE SOFTWARE, OR OTHER INFORMATION CONTAINED HEREIN OR THE USE THEREOF.

Sony Electronics Inc. reserves the right to make any modification to this manual or the information contained herein at any time without notice. The software described herein may also be governed by the terms of a separate user license agreement.

Sony, VAIO, VAIO Digital Studio and the VAIO logo are trademarks of Sony. Microsoft, Windows, and the Windows 98 logo are registered trademarks of Microsoft Corporation. Intel is a trademark of Intel Corporation. K56flex is a trademark of Lucent Technologies Inc. and Rockwell International. All other trademarks are trademarks of their respective owners.

Safety Information

Owner's Record

The model number and serial number are located on the back of your VAIO computer. Record the serial number in the space provided here. Refer to the model and serial number when you call your Sony Service Center.

Model Number: PCV-R532DS

Serial Number: _____

WARNING

- To prevent fire or shock hazard, do not expose your VAIO computer to rain or moisture.
- Never install modem or telephone wiring during a lightning storm.
- Never install telephone jacks in wet locations unless the jack is specifically designed for wet locations
- Never touch uninsulated telephone wire or terminals unless the telephone line has been disconnected at the network interface.
- Use caution when installing or modifying telephone lines.
- Avoid using the modem during an electrical storm.
- Do not use the modem or a telephone to report a gas leak in the vicinity of the leak.

! The use of optical instruments with this product will increase eye hazard.

Regulatory Information

Declaration of Conformity

Trade Name: SONY
Model No.: PCV-R532DS
Responsible Party:
Sony Electronics Inc.
Address:
1 Sony Drive
Park Ridge, NJ 07656
Telephone No: 201-930-6970

This device complies with Part 15 of FCC Rules. Operation is subject to the two following conditions: (1) This device may not cause harmful interference, and (2) this device must accept any interference received, including interference that may cause undesired operation.

This equipment has been tested and found to comply with the limits for a Class B digital device, pursuant to Part 15 of the Rules. These limits are designed to provide reasonable protection against harmful interference in a residential installation. This equipment generates, uses, and can radiate radio frequency energy and, if not installed and used in accordance with the instructions, may cause harmful interference to radio communications. However, there is no guarantee that interference will not occur in a particular installation. If this equipment does cause harmful interference to radio or television reception, which can be determined by turning the equipment off and on, the user is encouraged to try to correct the interference by one or more of the following measures:

- Reorient or relocate the receiving antenna.
- Increase the separation between the equipment and the receiver.
- Connect the equipment into an outlet on a circuit different from that to which the receiver is connected.

- Consult the dealer or an experienced radio/TV technician for help.

You are cautioned that any changes or modifications not expressly approved in this manual could void your authority to operate this equipment.

Only peripherals (computer input/output devices, terminals, printers, etc.) that comply with FCC Class B limits may be attached to this computer product.

Operation with non-compliant peripherals is likely to result in interference to radio and television reception.

All cables used to connect peripherals must be shielded and grounded.

Operation with cables, connected to peripherals, that are not shielded and grounded, may result in interference to radio and television reception.

FCC Part 68

This equipment complies with Part 68 of the FCC rules. The ringer equivalence number (REN) and the FCC registration number are printed on the modem board. If requested, this information must be supplied to the telephone company.

The REN is used to determine the quantity of devices which may be connected to the phone line. Excessive REN's on the telephone line may result in the devices not ringing in response to an incoming call. In most, but not all areas, the sum of the REN's should not exceed five (5.0). To be certain of the number of devices that may be connected to the line, as determined by the total REN's, contact the telephone company to determine the maximum REN for the calling area.

This modem uses the USOC RJ-11 telephone jack.

If this equipment causes harm to the telephone network, the telephone company will, when practical, notify you in advance that temporary discontinuance of service may be required. If advance notice isn't practical, the telephone company will notify you as soon as possible. Also, you will be advised of your right to file a complaint with the FCC if you believe it is necessary.

The telephone company may make changes in its facilities, equipment, operations or procedures that could affect the operations of the equipment. If this happens, the telephone company will notify you in advance, in order for you to make the necessary modifications in order to maintain uninterrupted service.

If trouble is experienced with this modem, for repair or warranty information, please contact 1-888-4SONYPC, or write to the Sony Customer Information Center, One Sony Drive, Park Ridge, NJ 07656.

This equipment cannot be used on telephone-company-provided coin service. Connection to Party Line Service is subject to state tariffs.

Repair of the modem should be made only by a Sony Service Center or Sony authorized agent. For the Sony Service Center nearest you, call 1-800-222-SONY (1-800-222-7669).

Telephone Consumer Protection Act of 1991

The Telephone Consumer Protection Act of 1991 makes it unlawful for any person to use a computer or other electronic device to send any message via a telephone facsimile machine unless such message clearly contains, in a margin at the top or bottom of each transmitted page or on the first page of the transmission, the date and time it is sent and an identification of the business, other entity, or individual sending the message, and the telephone number of the sending machine or such business, other entity, or individual.

In order to program this information into your facsimile, see your fax software documentation.



You are cautioned that any changes or modifications not expressly approved in this manual could void your authority to operate this equipment.

Contents

Notice to Users	ii
Safety Information	ii
Regulatory Information.....	iii
FCC Part 68	iv
Telephone Consumer Protection Act of 1991.....	iv

Chapter 1 — Identifying Components

Front View	2
Drives	3
Buttons and Switches	4
Indicators	5
Connectors	6
Rear View	7
Icons	8
I/O Connectors	10
Expansion Slots	14

Chapter 2 — Configuring Your System

Accessing the BIOS Setup Utility.....	16
Changing the Display's Power Management Settings.....	17
Configuring the System Board	19

Chapter 3 — Removing, Installing, and Replacing Components

Removing the Cover	22
Removing the Front Panel	24
Replacing the Front Panel	25
Replacing the Cover	26
Installing an Add-In Card	28
Removing an Add-in Card	29
Replacing the Lithium Battery	31
Installing System Memory	34
Removing a Memory Module	37
Removing a Slot Cover	39
Covering an Open I/O Slot	40
Installing a 3½" Internal Hard Disk Drive	41
Installing a 5¼" Internal Hard Disk Drive	45
Removing the Power Supply	48
Replacing the Power Supply	51

Chapter 4 — System Board

Connectors.....	54
Front Panel Header (J25)	54
Diskette Drive Connector	55
Memory Module (DIMM) Connectors	56
PCI Slot Connectors.....	57
IDE Connectors	58
Power Connector	58
KEYBOARD and MOUSE Connectors	59
USB Connectors	60
SERIAL 1, PRINTER, and MONITOR Connectors	61
Fan Connectors	64
GAME Connector.....	65
HEADPHONES, LINE IN, MIC Connectors	66
CD-IN Connector	67
Modem Connector	68
AUX-IN Connector	69
Configuration Jumper	70

Chapter 5 — Fax/Modem Card

Chapter 6 — i.LINK[®] Card

Chapter 7 — CMOS Setup Options

Main Screen	77
Advanced Screen	79
Power Screen.....	85
Boot Screen	87
Exit Screen	88

Chapter 8 — Miscellaneous Technical Information

About User and Supervisor Passwords	90
Beep Code Error Messages	91
PCI Configuration Status and Error Messages	92
DMA Channel Assignments	94
System I/O Address Map	95
Memory Map	97
IRQ Settings	98

Chapter 9 — Specifications

Processor	99
Chipset	99
PCI Bus	99
Memory Modules (DIMMs)	99
DIMM Configurations	100
L2 Cache	100
Graphics	100
Audio	101
Communications	101
I/O and Expansion Slots	101
Drives and Controllers	102
System BIOS	102

Chapter 1

Identifying Components

The following sections identify and describe each component that is visible from the exterior of the VAIO Digital Studio™ Computer. Internal components are identified in the appropriate section of this manual.

Front View

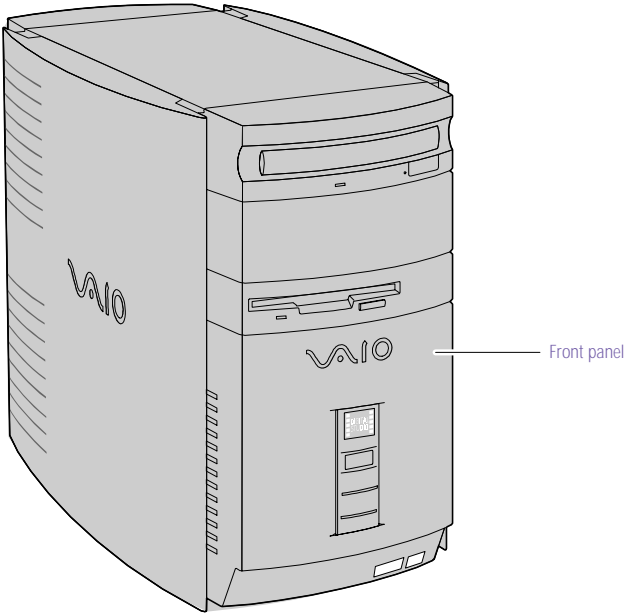

Drives

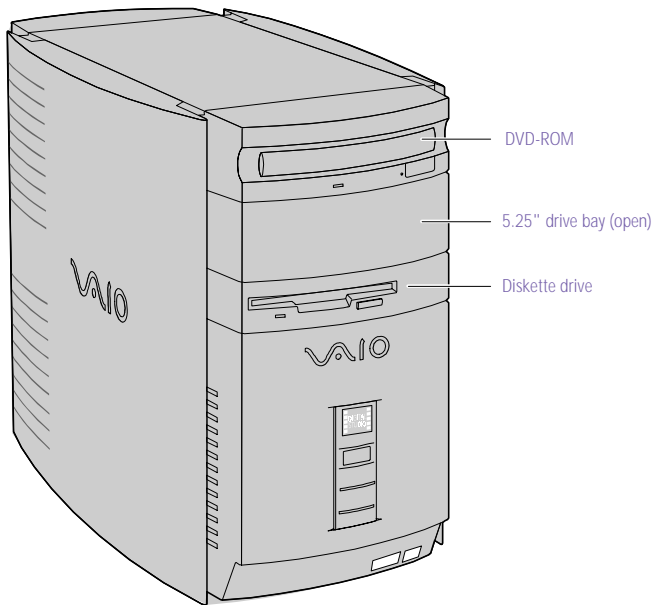

FRNTPNLA.VSD

<i>Drive</i>	<i>Description</i>
Diskette drive	3.5-inch, 1.44 Mbyte.
DVD-ROM drive	DVD-ROM read: 8X (maximum performance). CD-ROM read: 40X (maximum performance).

* Data on a DVD-ROM is read at a variable transfer rate, ranging from 3.3X at the innermost track to 8X at the outermost track (the data transfer standard 1X rate is 1385 kbytes/s). The average data transfer rate is 5.6X (7634 kbytes/s). Data on a CD-ROM is read at a variable transfer rate, ranging from 17.2X at the innermost track to 40X at the outermost track (the data transfer standard 1X rate is 150 kbytes/s). The average data transfer rate is 28.6X (4293 kbytes/s).

Buttons and Switches

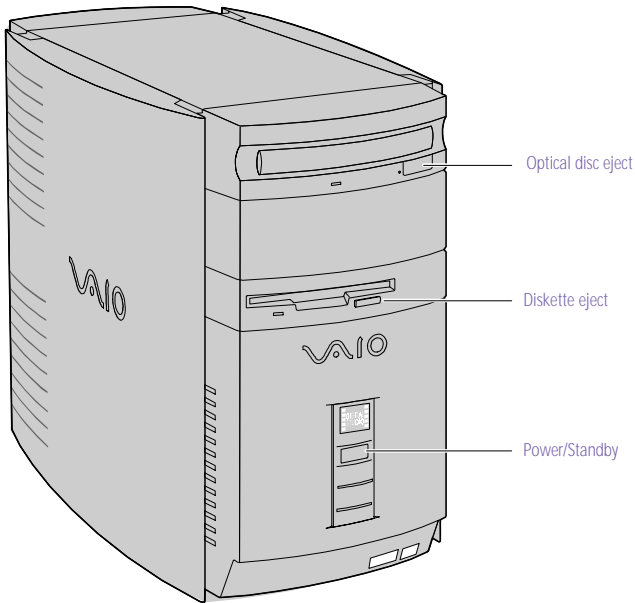

FRNTPNLB.VSD

<i>Button or switch</i>	<i>Description</i>
Power/Standby switch	Turns system power on, off, or into standby mode.
Diskette eject button	Ejects a diskette.
Optical disc eject button	Automatically opens and closes the optical drive tray.

Indicators

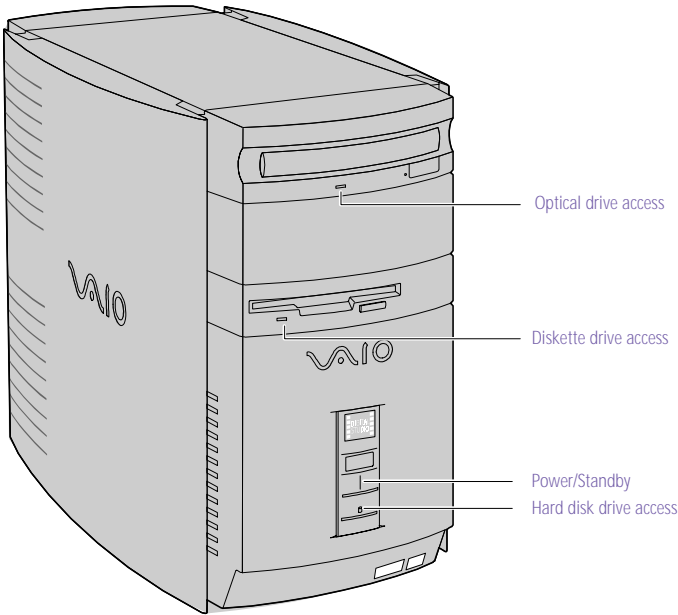

FRNTPNLC.VSD

<i>Indicator</i>	<i>Description</i>
Power/Standby indicator	Standby (amber) indicates the computer is in standby mode. On (green) indicates the computer is out of standby mode, ready to use. Off (no color) indicates the computer is turned off.
Diskette drive access indicator	On (green) indicates diskette drive activity.
Optical drive access indicator	On (orange) indicates CD-ROM activity.
Hard disk drive access indicator	On (orange) indicates hard disk drive activity.

Connectors

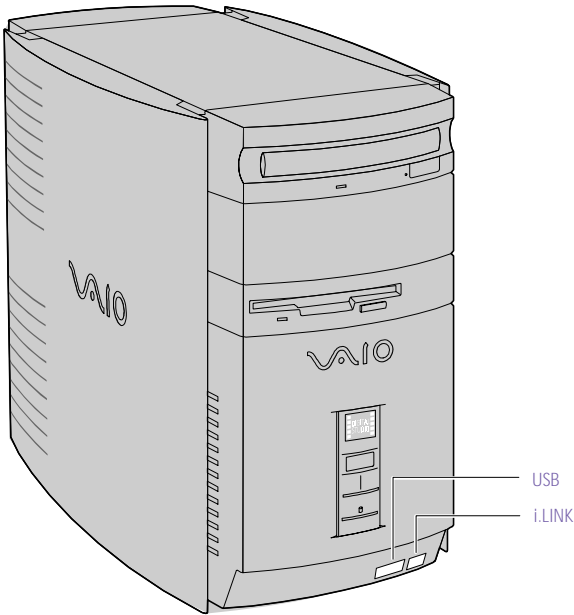

FRNTPNLD.VSD

<i>Connector</i>	<i>Description</i>
i.LINK® (IEEE-1394)*	Connects to a digital device that has a 4-pin i.LINK connector.
USB	Connects to USB devices.

* To connect to a 6-pin i.LINK device, use the i.LINK connector on the back of the system. A 6-pin i.LINK connector can supply power from the computer to the device if the device also has a 6-pin i.LINK connector. A 4-pin i.LINK connector cannot supply power to the device.



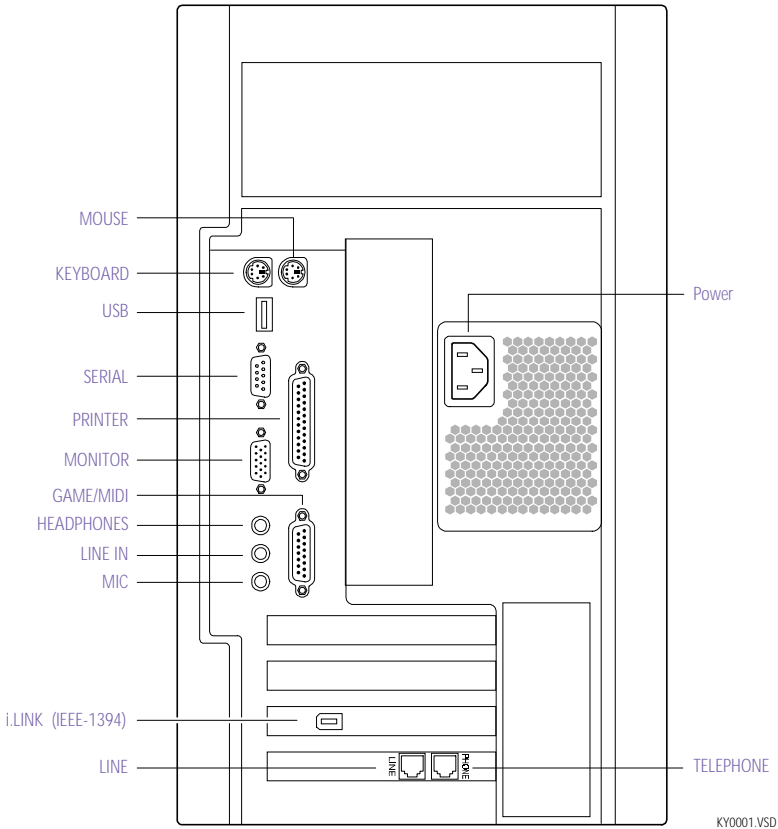



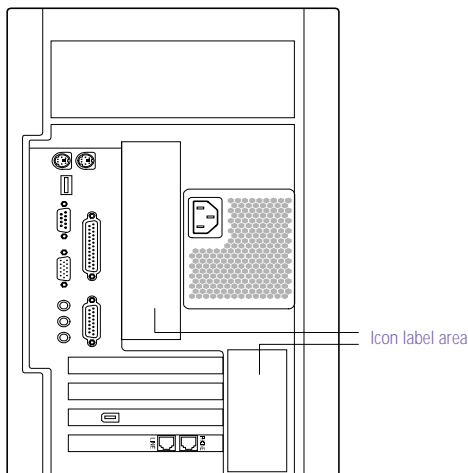



Rear View





Icons



OM04692X.VSE

<i>Icon</i>	<i>Description</i>
	MOUSE connector
	KEYBOARD connector
	USB (Universal Serial Bus) connector
	SERIAL connector
	PRINTER connector
	GAME/MIDI connector
	HEADPHONES connector
	LINE IN jack (audio)
	MIC (microphone) jack
	MONITOR connector
	LINE (for telephone line from primary service jack)

<i>Icon</i>	<i>Description</i>
	TELEPHONE (for phone)
	i.LINK (IEEE-1394)

I/O Connectors

The following section identifies the various I/O connectors.

KEYBOARD and MOUSE

The KEYBOARD and MOUSE connectors are physically identical and have the same pinout. They are standard 6-pin PS/2[®]-type female connectors.

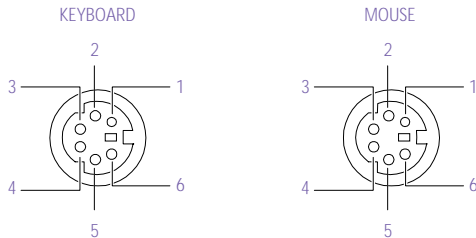

KY0002.VS

USB Connectors

The USB connectors are standard 4-pin USB connectors. A USB connector is located at the front and rear of the system.

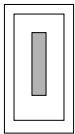

KY0003.VS

SERIAL Connector

The SERIAL connector is a standard 9-pin DB-9 male connector.

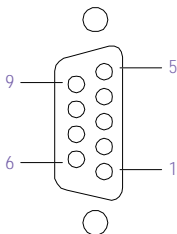

KY0057.VSD

PRINTER Connector

The **PRINTER** connector is a standard 25-pin DB-25 female connector.

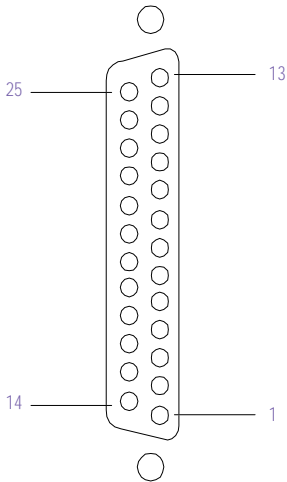

KY0005.VSD

MONITOR

The **MONITOR** connector is a standard 15-pin female high-density VGA-type connector.

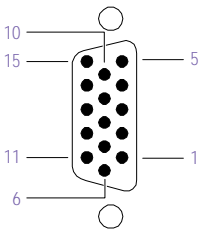

KY0004.VSD

GAME Connector

The GAME connector is a standard 15-pin DB-15 female connector. The GAME connector is also used to connect MIDI devices.

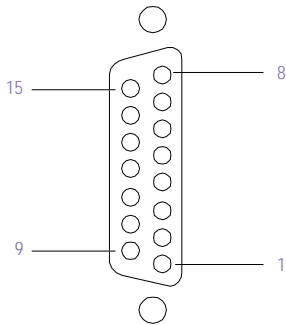

KY0012.VSD

MIC, LINE IN, and HEADPHONES

The MIC, LINE IN, and HEADPHONES jacks are physically identical, but have different connections. They are standard 3.5 mm stereo mini-jacks.

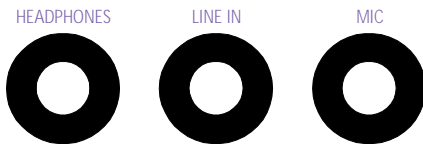

KY0013.VSC

<i>Connector</i>	<i>Description</i>
HEADPHONES	1.0 Vrms (typical).
MIC	Electrolet condenser microphone input.
LINE IN	1.0 Vrms (typical), 10 Kohm impedance.

TELEPHONE and LINE

The TELEPHONE and LINE jacks are physically identical and have identical connections. They are standard RJ-11 female phone jacks. However, the LINE jack is for connecting to a telephone line that comes from the wall, and the TELEPHONE jack is for connecting the computer to a telephone.

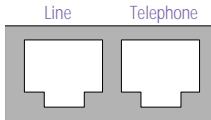

KY0014.VSD



Accidentally plugging a phone line from the wall into the modem's TELEPHONE jack, and a telephone into the LINE jack, will not damage the modem card or telephone equipment. However, the modem will not work correctly.

i.LINK® (IEEE-1394) Connectors

The 6-pin i.LINK connector on the back of the system can supply power from the computer to a device if the device also has a 6-pin i.LINK connector. The 6-pin connector supplies 10V to 12V and a maximum power of 6 watts.

The 4-pin i.LINK connector at the bottom of the front panel does not supply power.

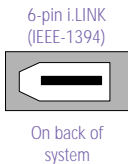

4-pin i.LINK
(IEEE-1394)



At bottom of
front panel

KY0087.VSD

Expansion Slots

There are four PCI slots, two of which are available for expansion (PCI #1 and PCI #2). The other two PCI slots are occupied by the i.LINK card (PCI #3) and the fax/modem card (PCI #4).

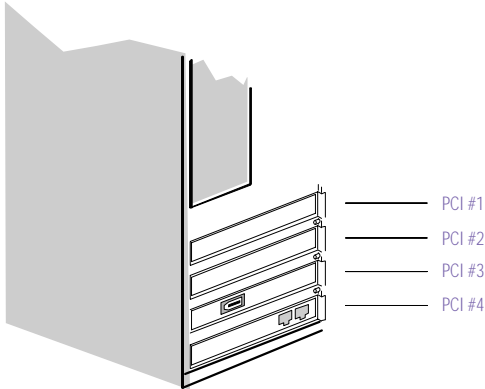

OM04577B.VSD

Chapter 2

Configuring Your System

This chapter contains information on configuring your system. Configuring your system can consist of the following:

- ❑ Making changes to the BIOS settings
- ❑ Making changes to the display's power management settings
- ❑ Changing the system board jumper position

Accessing the BIOS Setup Utility

You must access the BIOS Setup Utility to make changes to the BIOS settings (see “CMOS Setup Options” on page 75 for information on BIOS settings).

! Before rebooting the system, save any open files and exit the Microsoft® Windows® operating system.

- 1 Reboot the system.
- 2 When the Sony logo appears, press F3. The following message appears at the bottom of the screen.

Press <F2> for setup.

- 3 Press F2.

Each menu presents options for modifying the system configuration. Use the left and right arrow keys to select a menu from the menu bar. Use the up and down arrow keys to select items within a menu. Once an item is highlighted, use the plus/minus (+/-) keys to modify a setting.

If an item has a triangle (▶) to its left, this indicates that a sub-menu of options is available. Press ENTER to access a sub-menu. If a sub-menu contains items with a triangle, there is another layer of options from which to select.

- 4 Once you select an option, press ESC to back out of each menu until you reach the top level, where the menu bar appears.
- 5 To exit the BIOS setup utility, press ESC from any top-level screen and follow the prompts.

Changing the Display's Power Management Settings

A display that has power management capability is designed to operate on reduced power or shut itself off after the system has been idle for a specified period of time.

- 1 From the Start menu, point to Settings, then click Control Panel.
- 2 Double-click the Display icon.
- 3 Click the Screen Saver tab.

If your display is Energy-Star compliant or has other energy-saving features, the Energy saving features of the monitor dialog box appear. Otherwise, the options in the dialog box are grayed out.



- 4 Click Settings.

The Power Management Properties dialog box opens, with the Power Schemes tab displayed.

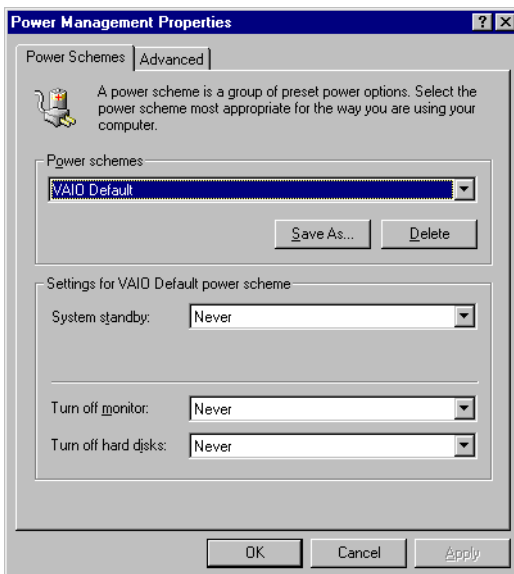

- 5 Select the power scheme that is most appropriate for the way you use your computer.

To change a power scheme, change the settings for System standby, Turn off monitor, and Turn off hard disks.

The System standby option allows you to specify the period of inactivity (in minutes) that you want to elapse before your computer goes on standby when your computer is running on AC power. Power is reactivated when you click the left mouse button or press a key.

The Turn off monitor option allows you to specify the period of inactivity (in minutes) that you want to elapse before your monitor turns off when your computer is running on AC power. The display reactivates when you move the mouse or press a key.

The Turn off hard disks option allows you to specify the period of inactivity (in minutes) that you want to elapse before your hard disks turn off when your computer is running on AC power.

- 6 To save a new power scheme, first modify the settings, click Save As, type a descriptive name, and then click OK.
- 7 Click the Advanced tab.



- 8 Select the desired settings, and then click OK.

Configuring the System Board

The system board contains a CMOS Clear configuration jumper, and two sets of reserved jumper blocks (do not change).

The CMOS and Non-Volatile RAM (NVRAM) settings are only cleared if the checksum test returns false. Access to specific setup fields is controlled by a supervisor password or user password.

The Clear CMOS mode removes the password that is stored in CMOS. No other parameters are cleared.

 The configuration jumpers should never need changing unless otherwise directed by a technical support or service technician.

! Before opening the system, save any open files, exit the Microsoft® Windows® operating system, turn off the power of the computer and all attached peripherals, and unplug the power cord.

- 1 Remove the cover (see “[Removing the Cover](#)” on page 22).
- 2 Set the jumpers as directed by a service technician (also see “[Configuration Jumper](#)” on page 70).

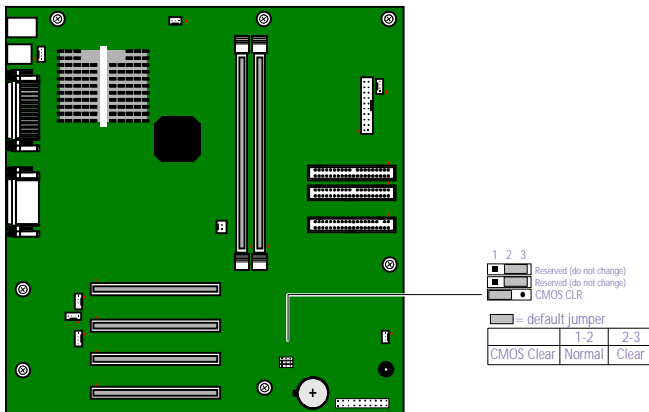

OM04588.VSD

- 3 Reinstall the cover (see “[Replacing the Cover](#)” on page 26).
- 4 Reinstall the front panel (see “[Replacing the Front Panel](#)” on page 25).

Chapter 3

Removing, Installing, and Replacing Components

This chapter describes removing, installing, and replacing major components for upgrading, reconfiguring, and troubleshooting the components.

! Before opening the system unit, save any open files, exit the Windows® operating system, turn off the power of the computer and all attached peripherals, and then unplug the power cord.

Removing the Cover

You must remove the cover to access the system board, add-in cards, power supply, battery, memory, and internal drives.

- 1 From the rear of the unit, press the two tabs on the right side.
- 2 Remove the frame from the unit by gently pulling it from left to right.

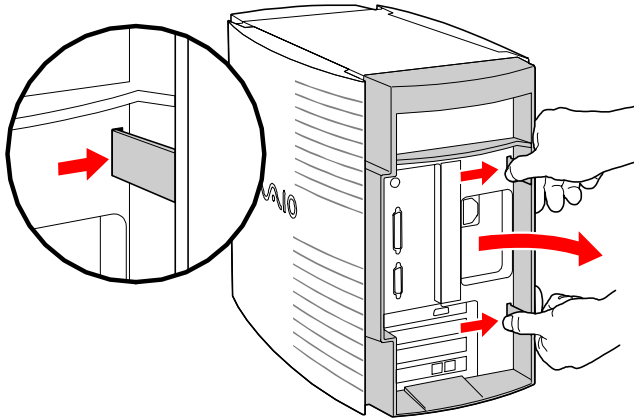

KY0064B.VSD

- 3 Remove the three screws from the metal back plate. The screws are located at the top center, and the lower left and right corners.

- 4 Lift the three-sided outer panel up and over the unit by pulling up on the large tab that extends from the top rear.

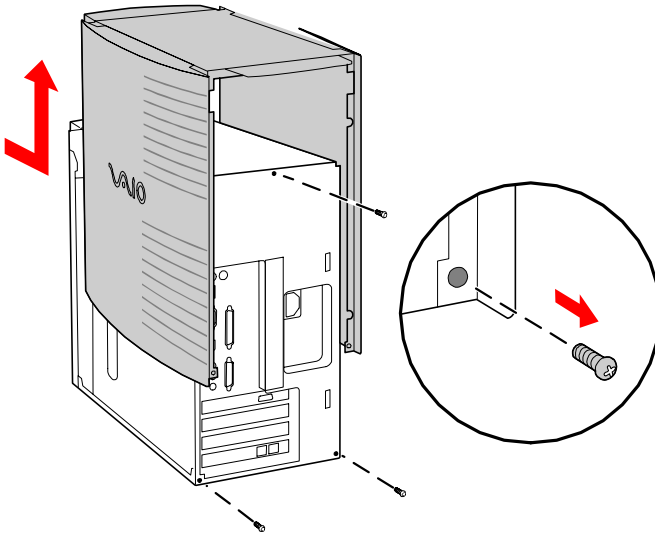

Removing the Front Panel

You must remove the front panel to install a 5¼" device.

- 1 Remove the cover (see "Removing the Cover" on page 22).
- 2 Push down and out on the two plastic tabs from inside the bottom of the chassis to release the bottom end of the front panel.

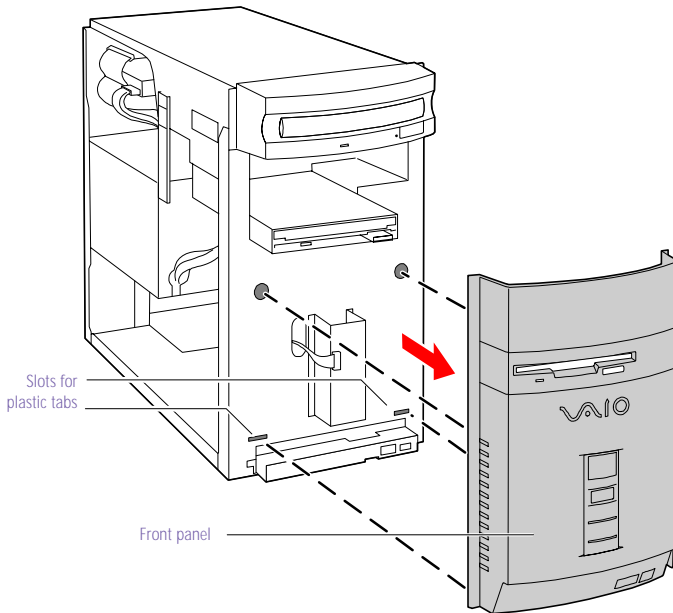

KY0091.VSD

- 3 Pull out the top end of the front panel to remove it.

Replacing the Front Panel

- 1 Insert the two plastic tabs (located on the bottom of the front panel) into the slots at the bottom of the chassis.
- 2 Push the bottom of the front panel in until the tabs snap into place.
- 3 Push the top of the front panel in until it is flush with the chassis .

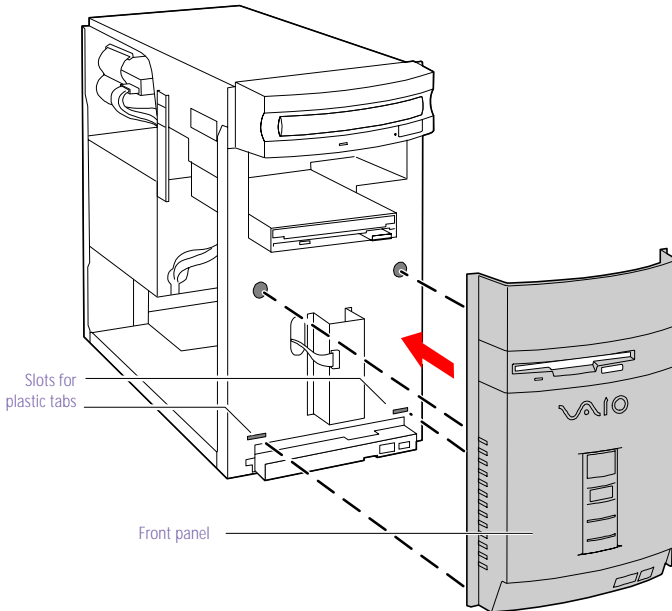

Replacing the Cover

- 1 Align the three-sided outer panel over the chassis and lower it onto the unit so that the tabs slip into the lips on the unit.
- 2 Insert the three screws (removed earlier) to secure the panel.

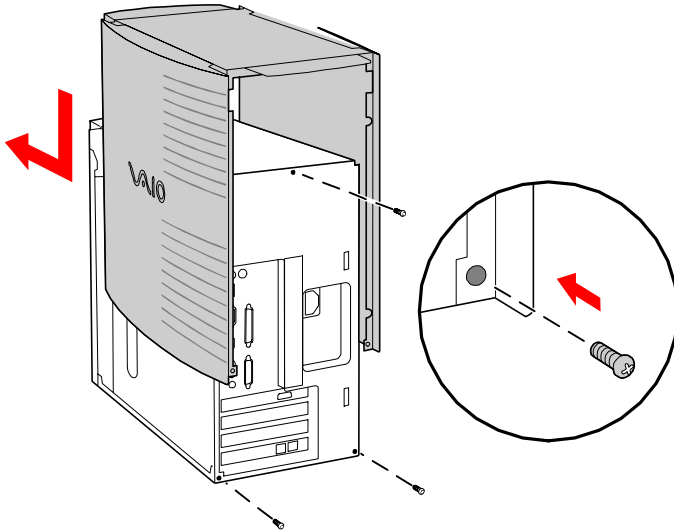

KY0067.VSD

- 3 Insert the three small tabs on the frame into the slots on the left side of the unit.
- 4 Slip the two larger tabs on the frame into the slots on the right side of the unit.

- 5 Gently press the frame in until it clicks into position.

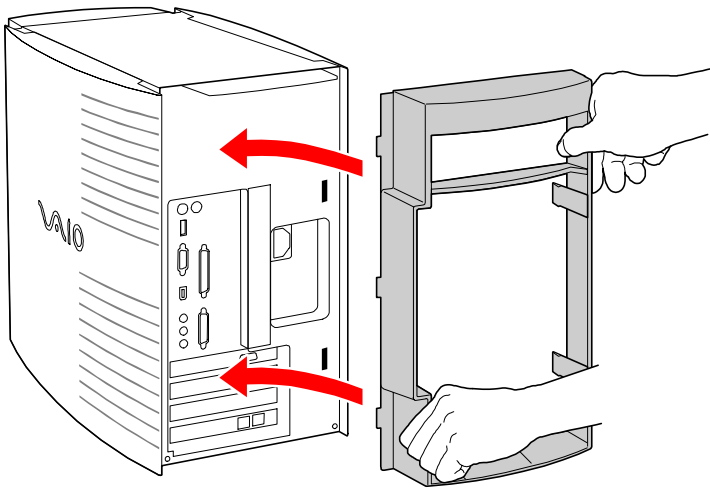

Installing an Add-In Card

! Before opening the system unit, save any open files, exit Windows, turn off the power of the computer and all attached peripherals, and then unplug the power cord.

- 1 Remove the cover (see “[Removing the Cover](#)” on page 22).
- 2 Locate an available expansion slot connector.
- 3 Remove the slot cover adjacent to the selected slot connector (see “[Removing a Slot Cover](#)” on page 39).
- 4 Insert the add-in card into the PCI slot connector. Use a gentle rocking motion, pressing down until the card is fully seated.

 Align the card's bracket so that the bottom of the bracket fits into the slot at the bottom of the chassis. Assure that the top of the bracket fits snugly against the chassis lip after the card is fully inserted.

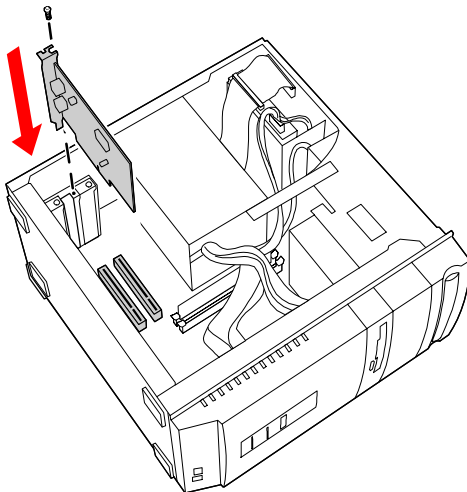

KY0070.VSD

- 5 Replace the screw that secures the card.
- 6 Attach any necessary cables to the card (see the instructions that came with the add-in card).
- 7 Replace the cover (see “[Replacing the Cover](#)” on page 26).
- 8 Turn on the computer and follow any instructions that came with the add-in card.

Removing an Add-in Card

! Before opening the system unit, save any open files, exit the Windows® operating system, turn off the power of the computer and all attached peripherals, and then unplug the power cord.

- 1 Remove the cover (see “Removing the Cover” on page 22).
- 2 Disconnect any cables attached to the add-in card you want to remove.
- 3 Remove the screw that secures the add-in card to the chassis.
- 4 Remove the add-in card from the PCI slot connector and store the card in an anti-static wrapper for future use.

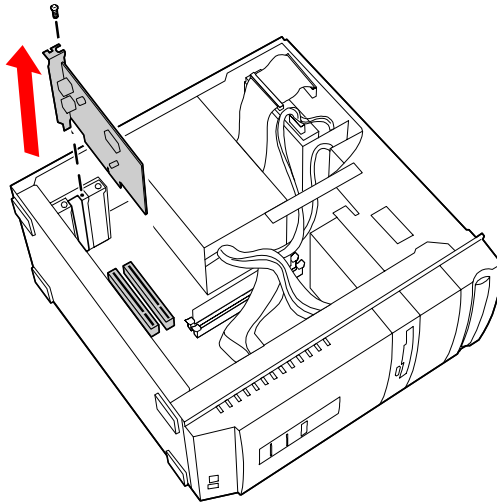

KY0071.VSD

 Grasp the card with one hand on each end, and gently pull up as you rock the card from side to side.

! Hold the add-in card by its edges and do not touch any components or connector contacts on the card. Static electricity in your body may damage sensitive components on the card. As a precaution, touch any exposed metal part on the metal chassis (preferably the metal part on the power supply) before handling an add-in card to discharge any static electricity in your body.

- 5 If you do not replace the card or install another add-in card, install a slot cover over the vacant slot at the rear of the chassis (see “[Covering an Open I/O Slot](#)” on page 40).
- 6 Replace the cover (see “[Replacing the Cover](#)” on page 26).

Replacing the Lithium Battery

You may need to replace the lithium battery if your computer consistently loses the date or time settings after turning it off. The lithium battery has a typical life of three years, after which the battery may be too weak to power the CMOS memory.

! When you remove the lithium battery, all values stored in the CMOS memory (BIOS setup values and Plug and Play values) may be lost. Although the computer can hold the charge for a short time while replacing the battery, it is safer to assume that the settings will be lost. When the values are lost, the BIOS values revert to their factory-default settings (see “[Accessing the BIOS Setup Utility](#)” on page 16).

Do not handle damaged or leaking batteries.

The lithium battery may explode if mistreated. Do not disassemble it or dispose of it in fire.

- 1 Reboot your computer by selecting Shut Down... from the Start menu, and then selecting Restart the computer.
- 2 If the error message “Error: Check date and time settings” appears during the reboot sequence, press F2 during the reboot process to access the BIOS Setup Utility. Otherwise it is not necessary to replace the battery at this time, and you can skip all remaining steps.
- 3 Compare all the BIOS options to their default settings (see “[CMOS Setup Options](#)” on page 75). Make a list of all the BIOS options that are different from their default values. You will refer to this list when you restore the BIOS settings later.
- 4 Select Exit Discarding Changes from the main menu using the right arrow key.
- 5 Press Enter, type Y when prompted to discard changes, then press Enter to exit the BIOS Setup Utility.
- 6 Turn off the computer and unplug the power cord.
- 7 Remove the cover (see “[Removing the Cover](#)” on page 22).

- 8 If necessary, remove any add-in cards (see “[Removing an Add-in Card](#)” on page 29) to gain access to the battery. You may also need to disconnect some cables.

! Touch any exposed metal part of chassis to discharge static electricity in your body before handling an add-in card or other sensitive electronic component.

- 9 Insert a small flathead screwdriver into the small space at the top of the battery holder.

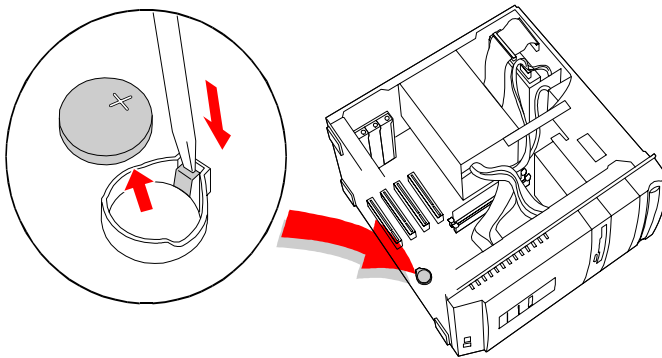

KY0072.VSD

- 10 Gently pry the battery out and dispose of it according to the instructions that came with the new battery.
- 11 Insert the new battery into the battery holder, with the plus (+) side up.



The Sony CR2032 battery is recommended. Using a type of battery other than a CR2032 may present a risk of fire or explosion.

- 12 Replace any add-in cards that were removed.
- 13 Reconnect any cables that were disconnected.
- 14 Replace the cover (see “[Replacing the Cover](#)” on page 26).
- 15 Reconnect the power cord and turn on the computer.

- 16 If the error message “Error: Check date and time settings.” appears during the reboot sequence, press F2 during the reboot process to access the BIOS Setup Utility. If no error message displays, the computer’s BIOS settings were retained during the battery replacement and you can skip the remaining steps.
- 17 Refer to the list you made in step 3 and restore any non-default BIOS settings (see “[CMOS Setup Options](#)” on page 75).
- 18 Select Exit Saving Changes from the main menu using the right arrow key.
- 19 Press Enter; type Y when prompted to discard changes, then press Enter to exit the BIOS Setup Utility.

The computer’s BIOS settings are now restored.

Installing System Memory

! Before opening the system unit, save any open files, exit Windows, turn off the power of the computer and all attached peripherals, and then unplug the power cord.

- 1 If necessary, remove the memory module you wish to replace (see “Removing a Memory Module” on page 37).
- 2 Remove the new memory module(s) from its anti-static package. Hold the memory module only by its edges to prevent static-electricity damage.
- 3 Choose the size of the memory module and configuration as shown in the following table. Memory modules can vary in size and speed between sockets. The minimum memory size is 8 MB; the maximum memory size is 256 MB. The BIOS automatically detects the type, size and speed of the memory modules.

Memory module configurations (MB)*

<i>DIMM1</i>	<i>DIMM2</i>
0, 8, 16, 32, 64, 128	0, 8, 16, 32, 64, 128

* The PCV-R532DS ships with 64 MB. SDRAM is expandable to 256 MB.

! Touch any exposed metal part of the chassis to discharge static electricity in your body before handling a memory module.



Use only 100 MHz FSB-supported memory. Do not mix 66 MHz memory with 100 MHz memory. Supports SDRAM memory. Does not support EDO memory or buffered DIMM memory.

- 4 Disconnect the power cord from the computer.
- 5 Remove the cover (see “Removing the Cover” on page 22).
- 6 Remove the power supply (see “Removing the Power Supply” on page 48).

- 7 Align the module over the appropriate socket, noting the location of pin 1 on the module and pin 1 on the socket.

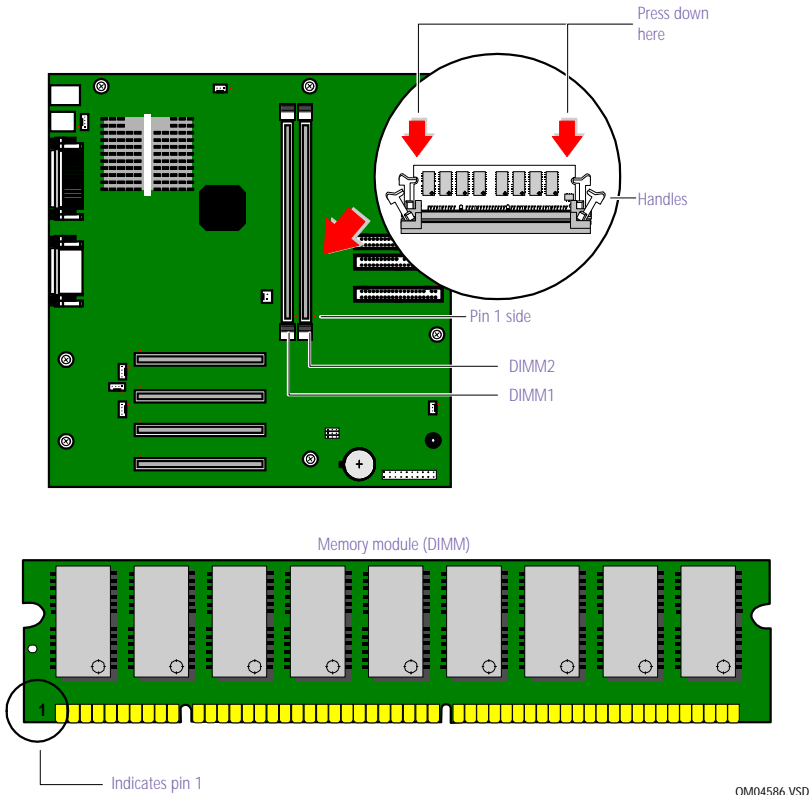

- 8 Carefully but firmly insert the edge of the module into the socket.
- 9 Press down firmly and evenly at both corners until the module is fully seated.

 When the module is fully seated, the handles on each side are straight up and locked into the slot on each side of the module. If the handles are not totally straight upright, continue to press down on each side of the module until the handles lock into place.

- 10 Replace the power supply (see “Replacing the Power Supply” on page 51).
- 11 Replace the cover (see “Replacing the Cover” on page 26).

12 Reconnect the power cord and turn on the computer.

Your computer automatically recognizes the extra memory and will configure itself accordingly when you turn on the computer. No further action is required.

Removing a Memory Module

You may need to remove a memory module if you change the memory configuration or replace a bad module.

! Before opening the system unit, save any open files, exit the Windows[®] operating system, turn off the power of the computer and all attached peripherals, and then unplug the power cord.

- 13 Remove the cover (see “Removing the Cover” on page 22).
- 14 Locate the memory module you wish to remove.

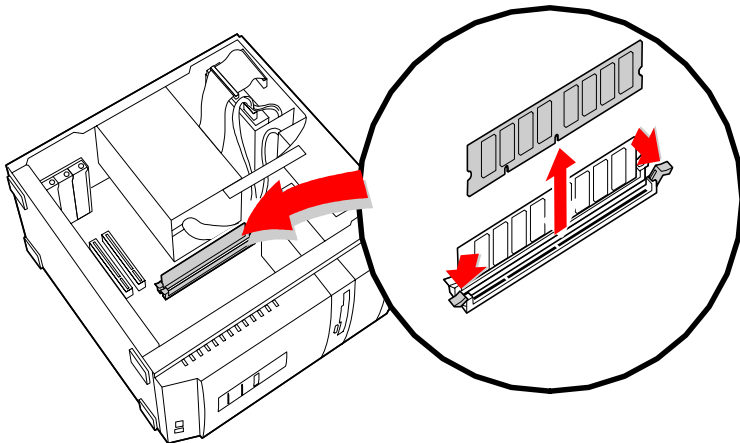

KY0073.VSD

 The memory modules are located beneath the power supply. You do not need to remove the power supply to reach the memory modules.

- 15 Reach around each side of the power supply and push down the handle on each side of the memory module to eject the module from its socket.

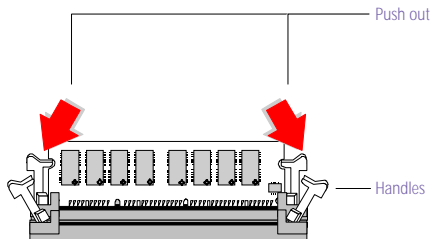

KY0042.VSD

- 16 Grasp one edge of the memory module and lift out. Store the module in a static-free bag.

! Touch any exposed metal part of the chassis to discharge static electricity in your body before handling the memory module.

Removing a Slot Cover

You remove a slot cover when you install an add-in card that occupies a previously-empty slot.

- 1 Disconnect the power cord from the computer.
- 2 Remove the cover (see “[Removing the Cover](#)” on page 22).
- 3 Locate the slot whose cover you want to remove.
- 4 Lay the system on its side.
- 5 Remove the screw from the slot cover.
- 6 Remove the loose slot cover and retain it for future use.

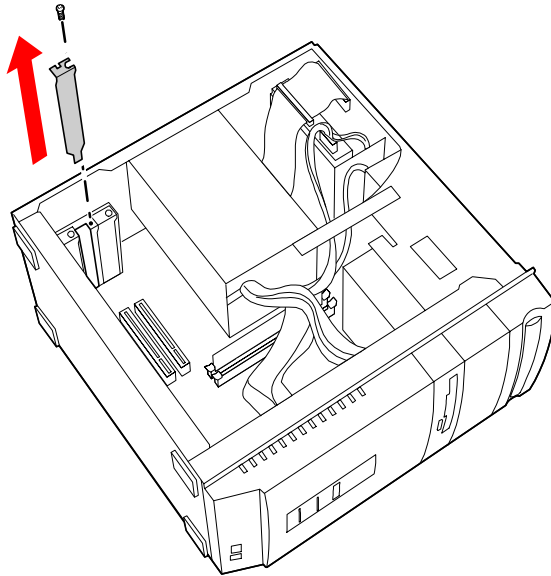

Covering an Open I/O Slot

Slot covers prevent air from escaping through the empty hole. If air escapes, the components inside the computer cannot be properly cooled. This may damage some components, especially the main processor (which generates the most heat).

- 1 Slide the tip of the slot cover (removed earlier) between the chassis and system board.

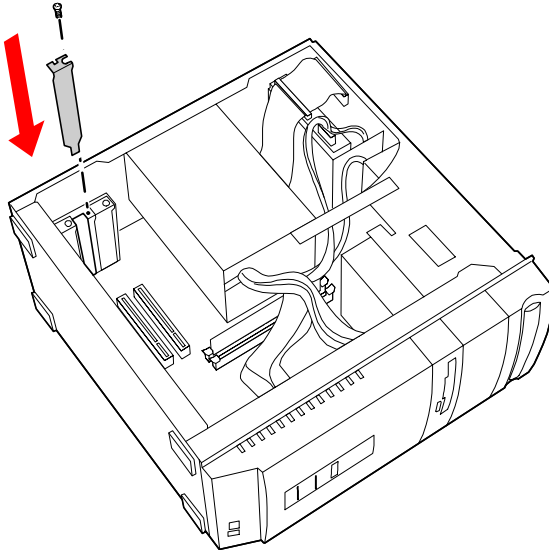

KY0076.VSD

- 2 Push the slot cover down until it rests firmly on the lip in the chassis. All add-in card brackets and slot covers rest on this lip.
- 3 Replace the screw (removed earlier) to secure the I/O slot cover.

Installing a 3½" Internal Hard Disk Drive

Your system comes with an available bay to hold an additional 3½" hard disk drive. The drive you install must not require front panel access. The hard disk drive access light blinks when either internal drive is active.

! Before opening the system unit, save any open files, exit Windows, turn off the power of the computer and all attached peripherals, and then unplug the power cord.

- 1 Configure the jumpers on the new drive as a primary slave (see your drive's documentation for configuration instructions).

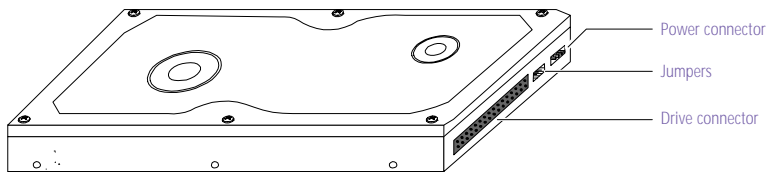

KY0084.VSD

- 2 Disconnect the power cord from the computer.
- 3 Remove the cover (see “[Removing the Cover](#)” on page 22).
- 4 Remove the four screws (A in next diagram) that secure the drive holder to the top of the chassis.

- 5 Slide the drive holder forward (B), and then out.

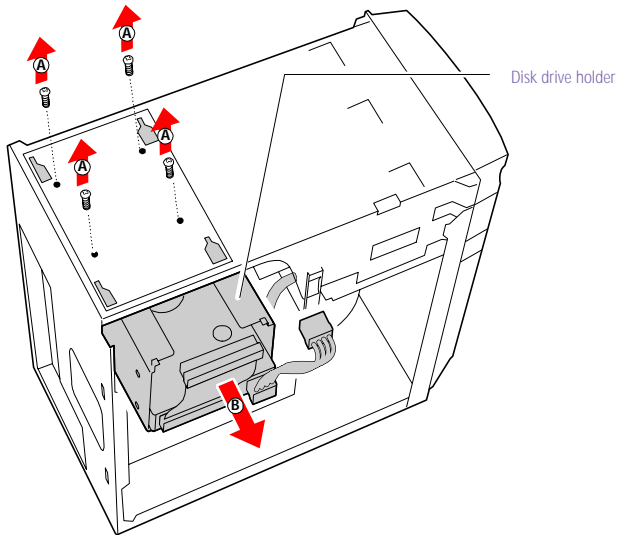

KY0081.VSD

- 6 Place the drive holder on top of the power supply.
- 7 Slide the new drive into the drive holder and align the holes on each side of the drive holder.

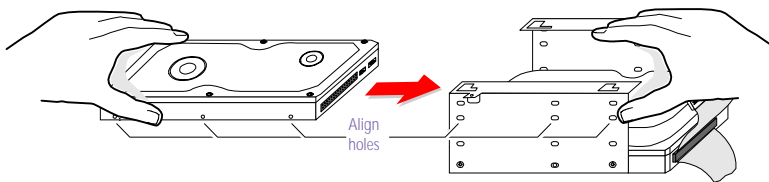

KY0083.VSD

- 8 Secure the drive to the drive holder using the two holes on each side of the drive holder (screws are provided with the new drive). Do not overtighten the screws.
- 9 Connect the second drive connector to the new drive (see next diagram).

- 10 Connect the second power connector to the new drive.

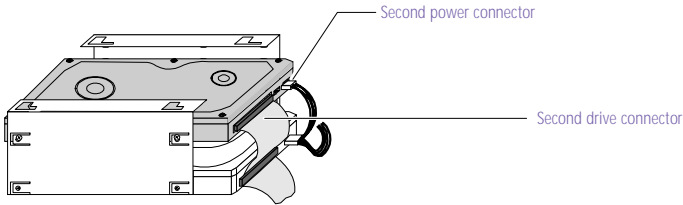

KY0085_VSD

- 11 Make sure the drive connector is connected securely to the motherboard.
- 12 Lower the drive holder down and slide it back into the chassis (A in next diagram). Be sure to align all four slots on the drive holder with the tabs on top of the chassis.
- 13 Slide the drive holder back so that the tabs slip into the notches.

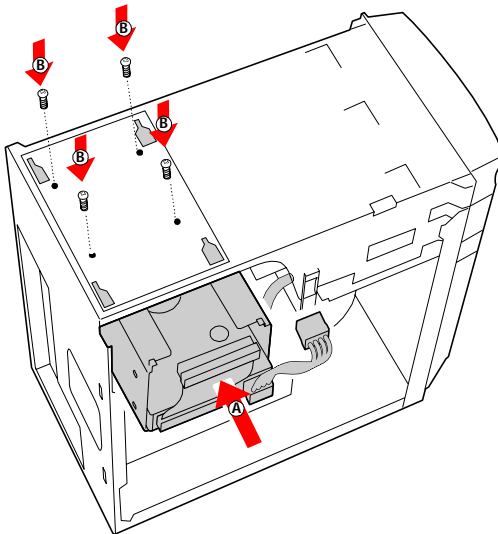

KY0086_VSD

- 14 Replace the four screws (B) that secure the drive holder to the chassis.
- 15 Replace the cover (see "Replacing the Cover" on page 26).

16 Reconnect the power cord and then turn on your computer.

Your computer automatically recognizes the new drive and configures itself accordingly when you turn it on. Format and partition the new drive following the instructions provided with the drive.

Installing a 5¼" Internal Hard Disk Drive

Your system comes with an available 5¼" bay to hold an additional 3½" or 5¼" hard disk drive. The drive you install can access the front panel. The hard disk drive access light blinks when either internal drive is active.

! Before opening the system unit, save any open files, exit the Windows® operating system, turn off the power of the computer and all attached peripherals, and then unplug the power cord.

- 1 Configure the jumpers on the new drive as a secondary slave (see your drive's documentation for configuration instructions).

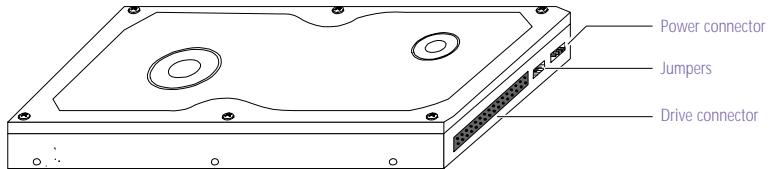

KY0084.VSD

- 2 Disconnect the power cord from the computer.
- 3 Remove the cover (see "Removing the Cover" on page 22).
- 4 Remove the front panel (see "Removing the Front Panel" on page 24).
- 5 Lay the system on its side (see following diagram).

- 6 Remove the drive bay cover (shiny and silver) by pushing it from behind (use a long object or your finger). Store for future use.

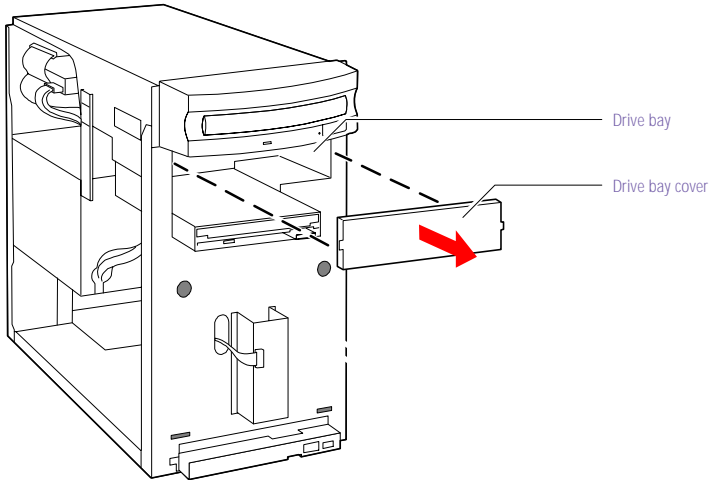

KY0092.VSD

- 7 Slide the drive into the drive bay until the holes on each side of the drive align with the holes on each side of the chassis.

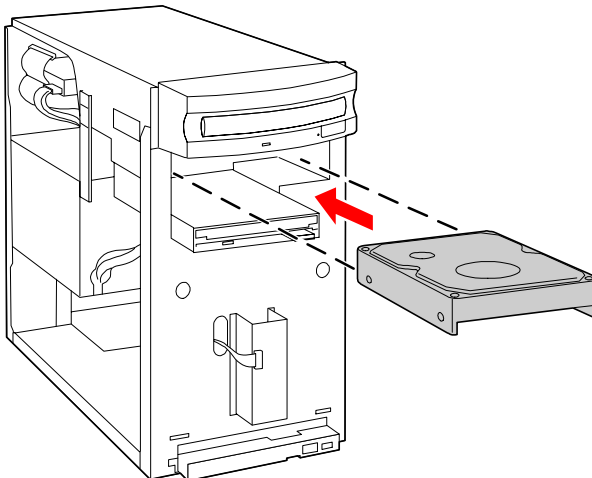

KY0094.VSD

 If the drive you are installing is a 3½" drive, you must attach conversion brackets so that the 3½" drive can fit inside of a 5¼" bay. See the instructions that came with your new drive.

- Secure the drive with four screws (provided with new drive). Do not overtighten the screws.

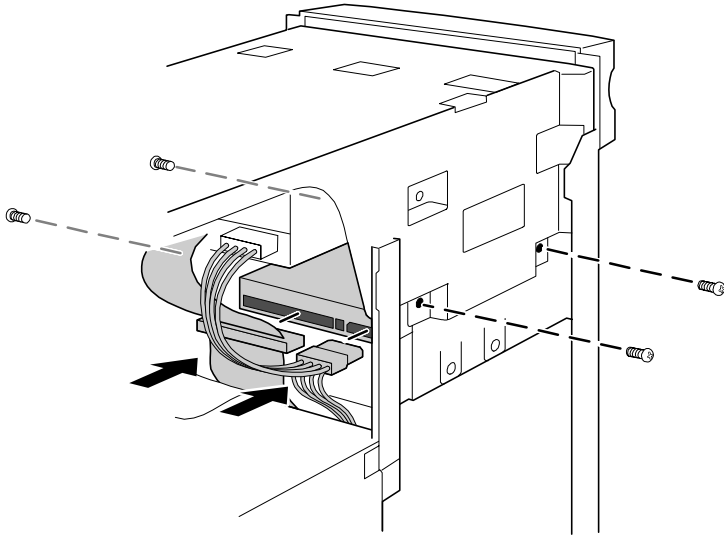

KY0095_VSD

- Attach the drive connector and power cable to the drive. Make sure the drive connector is connected securely to the motherboard.
- Replace the cover (see [“Replacing the Cover”](#) on page 26).
- Replace the front panel (see [“Replacing the Front Panel”](#) on page 25).
- Reconnect the power cord and then turn on your computer.

Your computer automatically recognizes the new drive and configures itself accordingly when you turn it on. Format and partition the new drive following the instructions provided with the drive.

Removing the Power Supply

You remove the power supply when you insert a memory module (see “Installing System Memory” on page 34).

- 1 Remove the three screws (A in next diagram) from the rear of the chassis.
- 2 Remove the screw (B) from the power supply bracket.

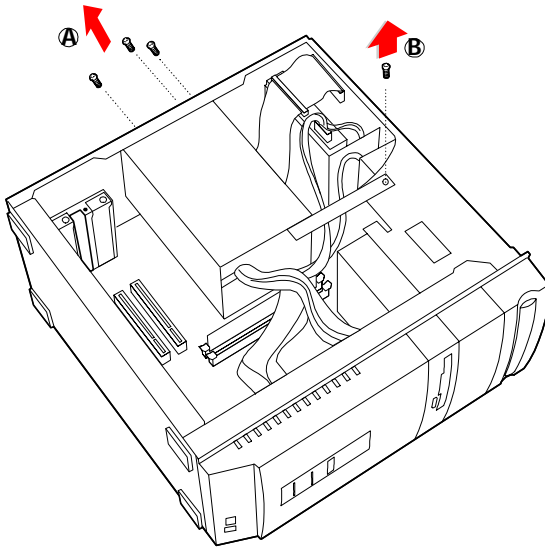

- 3 Slide the power supply back (towards the 3½" drive bay) about ½" (or until the power supply detaches from the chassis tabs), then lift up until the power supply clears the chassis lip.

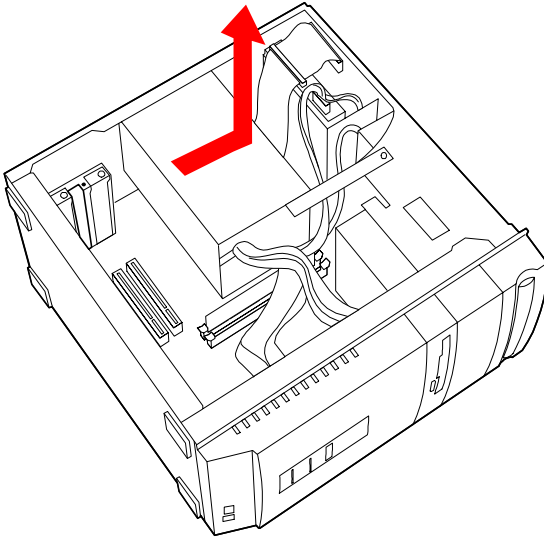

- 4 Rotate the power supply horizontally by 180 degrees counterclockwise and rest it on top of the chassis where the CD-ROM/DVD-ROM drive is located.

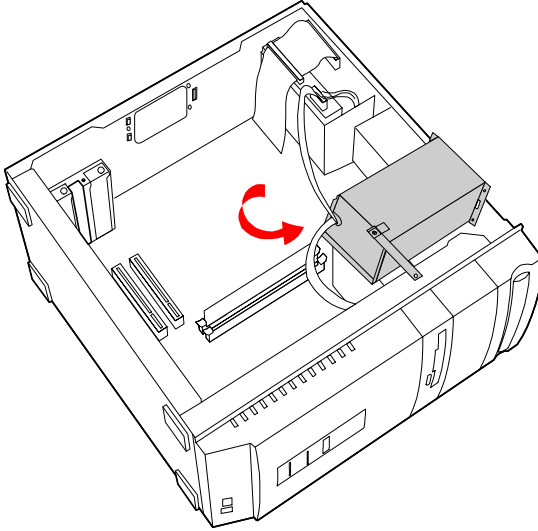

Replacing the Power Supply

- 1 Rotate the power supply horizontally by 180 degrees clockwise and lower it into the chassis until it is flush against the square hole at the rear of the chassis.
- 2 Slide the power supply forward (away from the 3½" drive bay) until the power supply latches onto the chassis tabs.
- 3 Replace the three screws that secure the power supply to the rear of the chassis.
- 4 Replace the screen that secures the power supply bracket to the chassis.

Chapter 4

System Board

This chapter identifies each component on the system board and provides a detailed description of each connector, jumper, and switch on the system board.

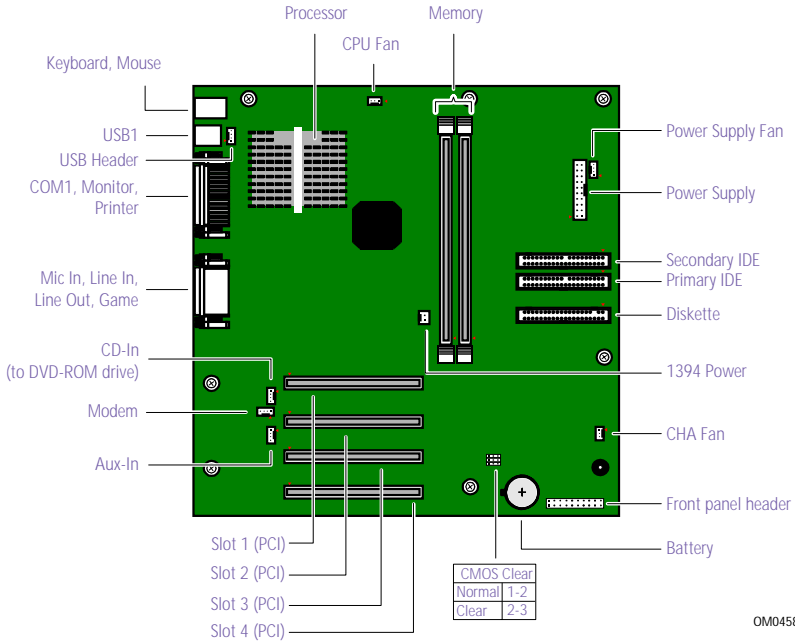

OM04581.VSD

Connectors

Front Panel Header (J25)

The front panel header is a 20-pin header (1 pin is removed for the key) that provides connections to various front panel functions. A 20-pin connector with only eight wires is used to interface the system board to the front panel.

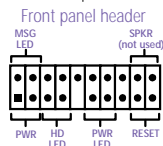
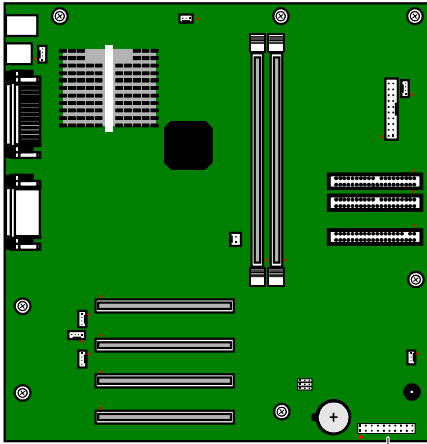

KY0031.VSD

<i>Name</i>	<i>Description</i>
SPEAKER	(not used)
PWR LED	Connects to the power-on indicator light on the front panel
HD LED	Connects to the hard disk drive access light on the front panel
SLEEP	(not used)
PWR	Connects to the power-on switch on the front panel
RESET	(not used)
MSG LED	Connects to the standby indicator light on the front panel.

Diskette Drive Connector

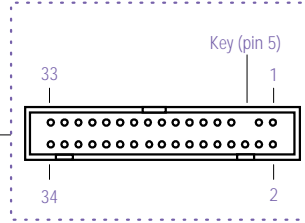
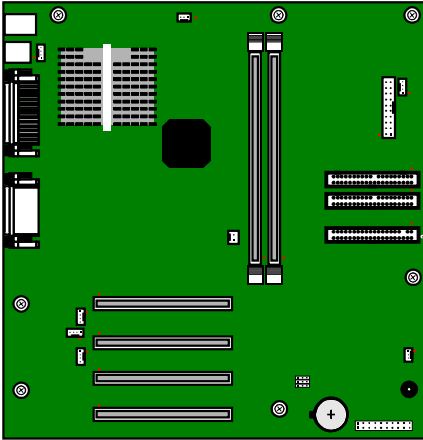

Memory Module (DIMM) Connectors

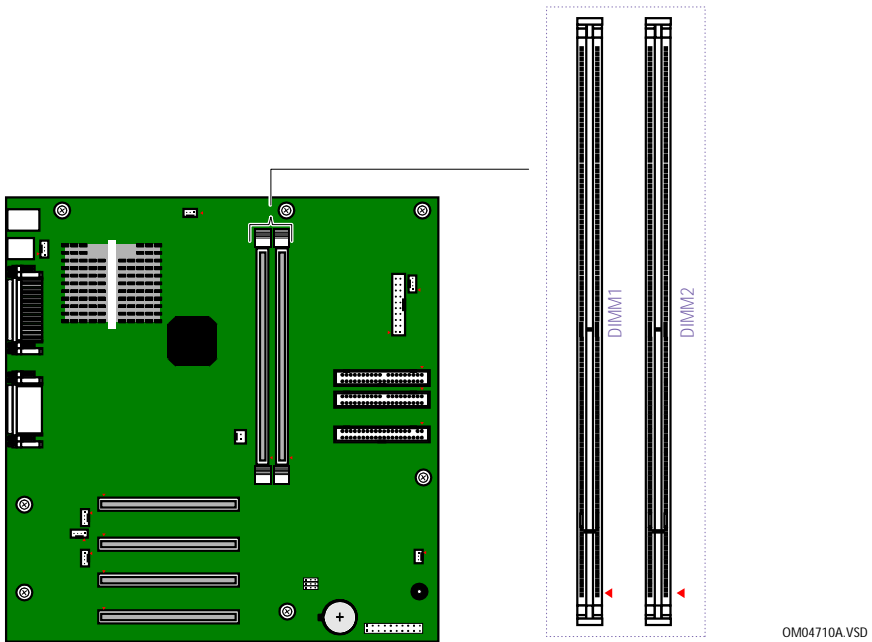

Both sides of each Dual Inline Memory Module (DIMM) look very similar. The side with pin 1 has a small "1" to the left of pin 1. Be sure to orient a DIMM correctly in the DIMM connector (a small triangle on the connector indicates pin 1).

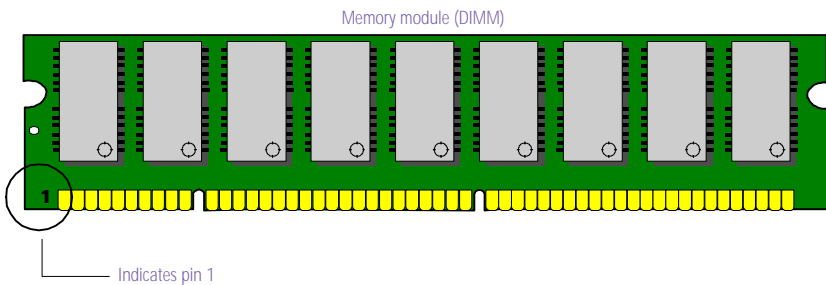

PCI Slot Connectors

There are a total of four PCI slot connectors (slot #1 to #4). Two PCI slot connectors (#1 and #2) are available. The other two PCI slots are occupied by the i.LINK[®] card and the fax/modem card. The PCI slots support 32-bit 5V and Universal (3.3/5V) PCI add-in cards.

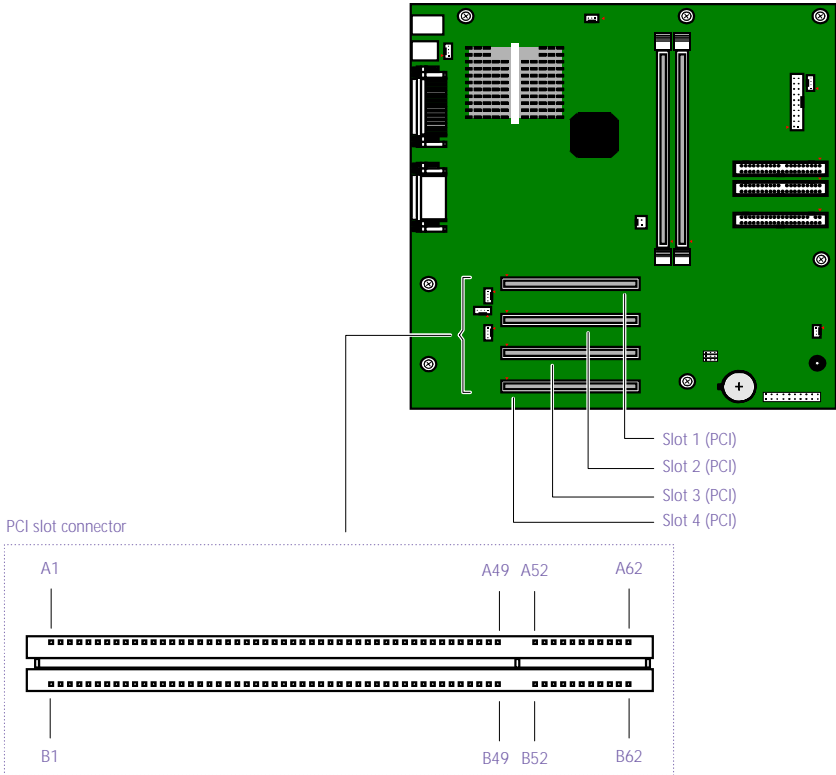

IDE Connectors

There are two IDE (Integrated Drive Electronics) connectors on the system board: a Primary IDE and a Secondary IDE connector.

Each IDE connector supports up to two IDE drives using a ribbon cable with two connectors.

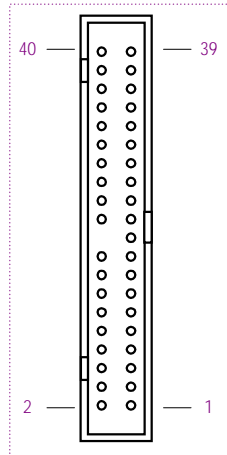
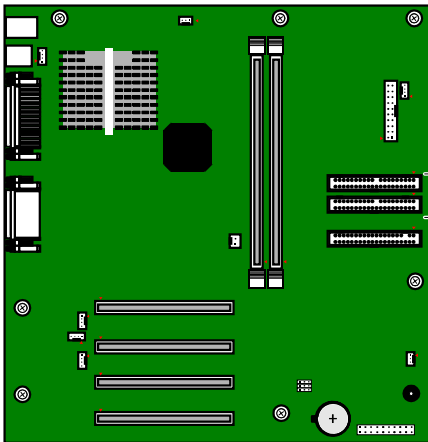

OM04701G.VSD

Power Connector

The power supply connector on the system board connects to the power supply connector labelled P1.

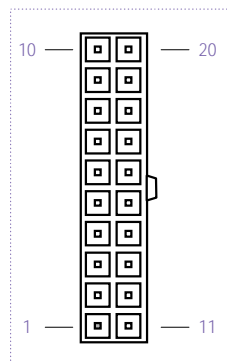
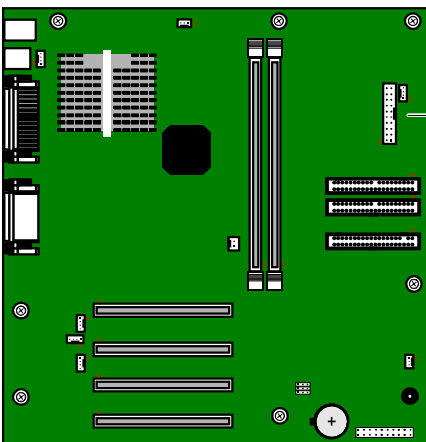

OM04701I.VSD

KEYBOARD and MOUSE Connectors

The KEYBOARD connector and the MOUSE connector are 6-pin female PS/2-type (mini-DIN) connectors. They have identical pinouts.

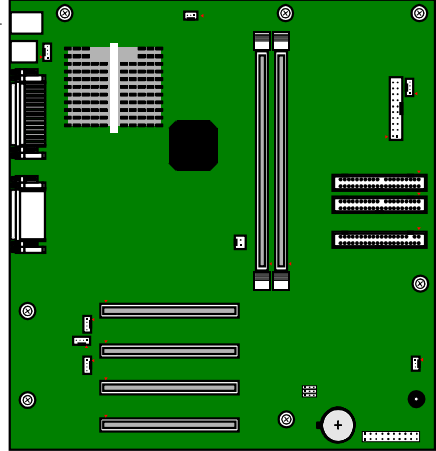
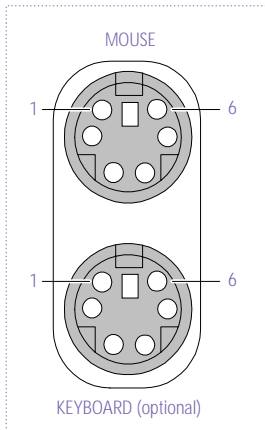

KY0032.VSD

KEYBOARD and MOUSE

Pin	Signal Name
1	DATA
2	NC
3	LOGIC GND
4	+5V (fused)
5	CLOCK
6	NC

USB Connectors

There are two USB ports that permit connection of two USB peripheral devices directly to the system without having to use an external hub.

USB2 is a standard USB connector accessible from the rear panel.

USBHEAD is a 4-pin single-line header that connects to a standard USB connector (USB1) accessible at the bottom of the front panel. An internal cable connects USBHEAD to an interface board behind the front panel.

If more USB devices are needed, connect an external hub to either USB1 or USB2.

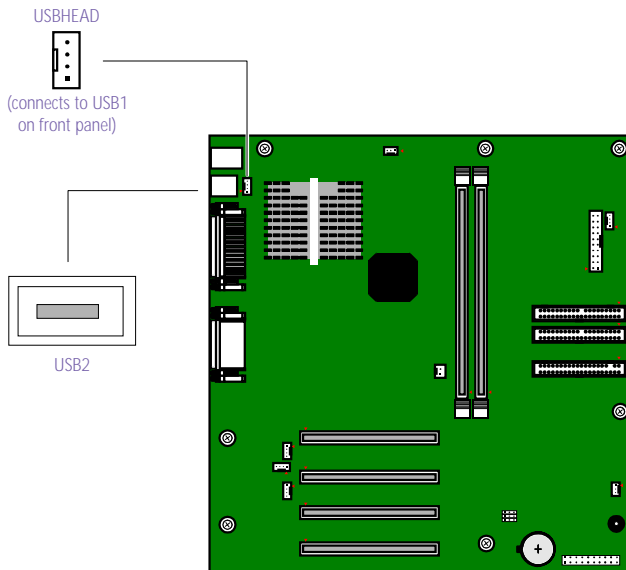

KY0033.VSD

USBHEAD (connects to USB1 on front panel)

Pin Signal Name

1 USBVCC2

2 USBP1#

3 USBP1

4 Ground

USB2

<i>Pin</i>	<i>Signal Name</i>
1	USBVCC1*
2	USBP0#
3	USBP0
4	Ground
5	USBVCC2*
6	USBP1#
7	USBP1
8	Ground

* Uses over-current protector.

SERIAL 1, PRINTER, and MONITOR Connectors

The SERIAL 1, PRINTER, and MONITOR connectors are mounted in a single bracket on the system board. The SERIAL 1 connector is a DB-9 male connector. The PRINTER connector is a DB-25 female connector. The MONITOR connector is a standard 15-pin female high-density VGA-type connector.

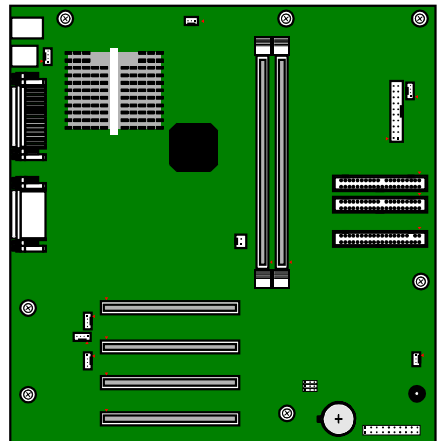
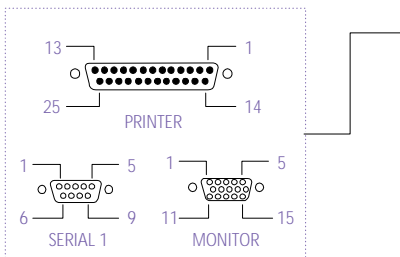

SERIAL 1 connector*Pin* *Signal Name*

1	DCD
2	RXD
3	TXD
4	DTR
5	LOGIC GND
6	DSR
7	RTS
8	CTS
9	RI

PRINTER connector*Pin* *Signal Name*

1	STROBE -
2	DATA BIT 0
3	DATA BIT 1
4	DATA BIT 2
5	DATA BIT 3
6	DATA BIT 4
7	DATA BIT 5
8	DATA BIT 6
9	DATA BIT 7
10	ACK -
11	BUSY
12	PE
13	SELECT
14	AUTO-FEED -
15	ERROR -
16	INIT -
17	SELECT-IN -
18	LOGIC GND
19	LOGIC GND
20	LOGIC GND
21	LOGIC GND
22	LOGIC GND

23	LOGIC GND
24	LOGIC GND
25	LOGIC GND

MONITOR connector*Pin* *Signal Name*

1	RED
2	GREEN
3	BLUE
4	GND
5	DDC GND
6	RED GND
7	GREEN GND
8	BLUE GND
9	NC
10	GND
11	GND
12	SDA
13	HORIZONTAL SYNC
14	VERTICAL SYNC
15	SCL

Fan Connectors

The CPU-FAN, PWR-FAN, and CHA-FAN connectors are 1 x 3-pin straight header connectors. PWR-FAN connects to the power supply and controls the power supply cooling fan. CPU-FAN and CHA-FAN connectors are not used.

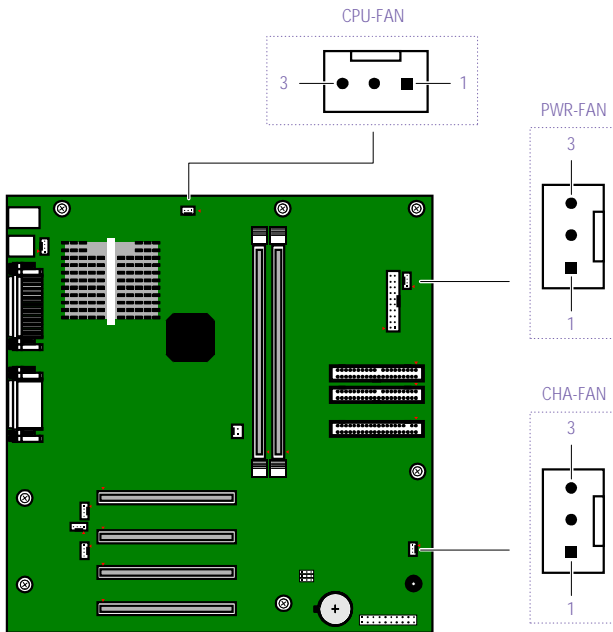

KY0034.VSD

CPU-FAN and PWR-FAN Connector

Pin	Signal Name
1	Ground
2	FAN_CTRL (+12V)
3	FAN_SEN

CHA-FAN Connector

Pin	Signal Name
1	Ground
2	FAN_CTRL (+12V)
3	FAN_SEN

GAME Connector

The GAME connector is a female DB-15 connector for connecting to a game controller/joystick or MIDI device.

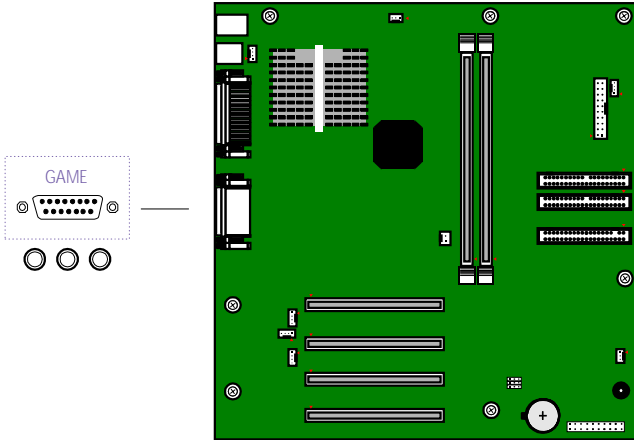

KY0056.VSD

GAME Connector

Pin *Signal Name*

1	GAMEVCC
2	JPYB0
3	JOYA0
4	GND
5	GND
6	JOYA1
7	JOYA2
8	GAMEVCC
9	GAMEVCC
10	JOYB2
11	JOYA2
12	MIDI_TxD
13	JOYA3
14	JOYB3
15	MIDI_RxD

HEADPHONES, LINE IN, MIC Connectors

The HEADPHONES jack is a stereo mini-jack (3.5 mm) that connects to headphones. The LINE IN jack is a stereo mini-jack (3.5 mm) that connects to a stereo audio source (not an audio source from a video device). The MIC In jack is a stereo mini-jack (3.5 mm) that connects to a microphone.

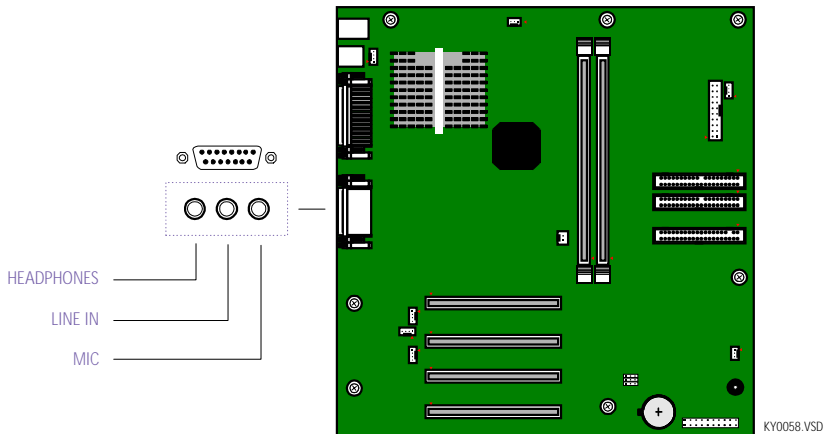

HEADPHONES

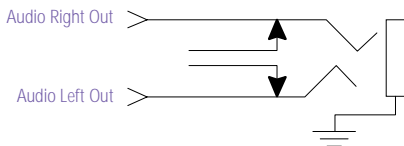

OM04713.VSD

LINE IN

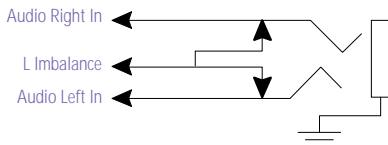

OM04713B.VSD

MIC

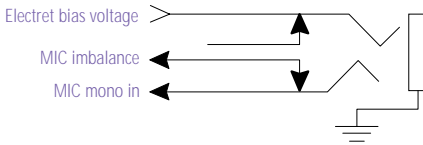

OM04713A.VSE

CD-IN Connector

The CD-IN connector on the system board is a 1 x 4-pin header connector that connects to the DVD-ROM drive's audio output connector.

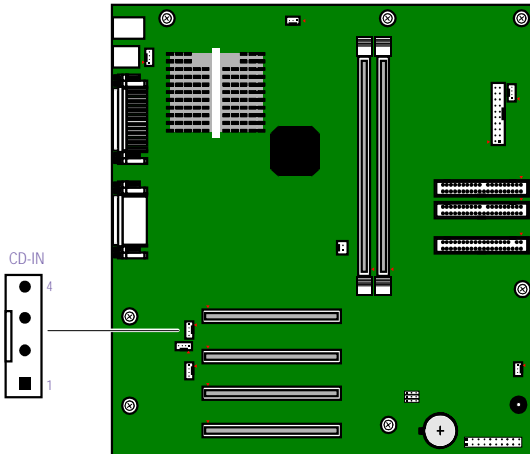

KY0062.VSD

CD-IN

Pin	Signal Name
1	Left Line In
2	Ground
3	Ground
4	Right Line In

Modem Connector

The Modem connector on the system board is a 1 x 4-pin header that is not in use.

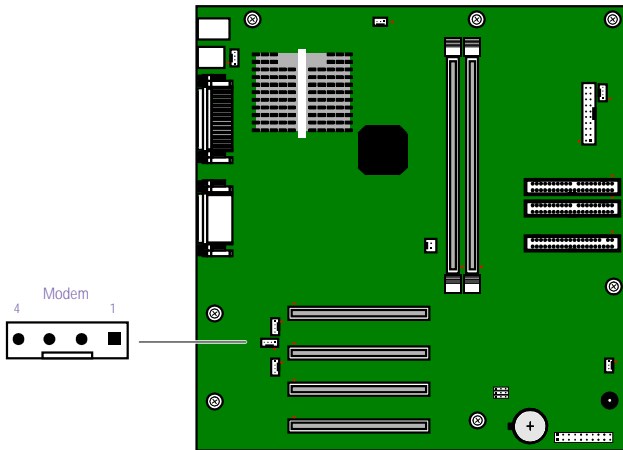

KY0062C.VSD

Modem

<i>Pin</i>	<i>Signal Name</i>
------------	--------------------

1	Ground
---	--------

2	Modem Out
---	-----------

3	Ground
---	--------

4	Phone In
---	----------

AUX-IN Connector

The AUX-IN connector on the system board is a 1 x 4-pin header connector that is not in use.

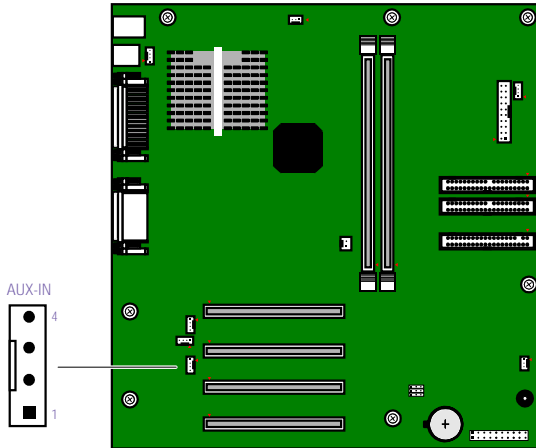

KY0062B.VSD

AUX-IN

<i>Pin</i>	<i>Signal Name</i>
------------	--------------------

1	Left Line In
---	--------------

2	Ground
---	--------

3	Ground
---	--------

4	Right Line In
---	---------------

Configuration Jumper

There is one user-configurable jumper for CMOS Clear. The other two jumpers are reserved (do not change).

The computer ships with CMOS Clear in the Normal position. Do not change the position of this jumper unless directed by a technical support person.

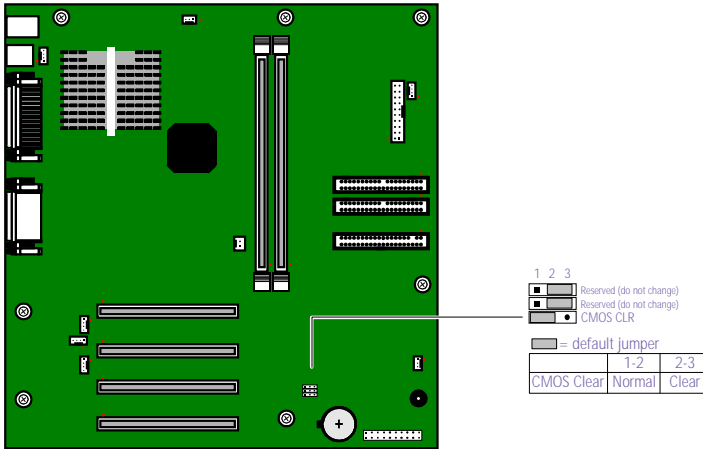

OM04588.VSD

Chapter 5

Fax/Modem Card

The fax/modem card occupies PCI slot #4. There are two RJ-11 jacks: one to connect a telephone line, and one to connect a phone.

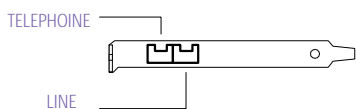

KY0038.VSC

Connectors

<i>Name</i>	<i>Connector Type</i>	<i>Description</i>
TELEPHONE	RJ-11	Connects to phone
LINE	RJ-11	Connects to telephone line

Chapter 6

i.LINK[®] Card

The i.LINK (IEEE-1394) card occupies PCI slot #3. There are four header connectors, but only two are used: CN3 connects to the power supply, and CN4 connects to the 4-pin i.LINK connector on the front chassis through an interface board on the front chassis.

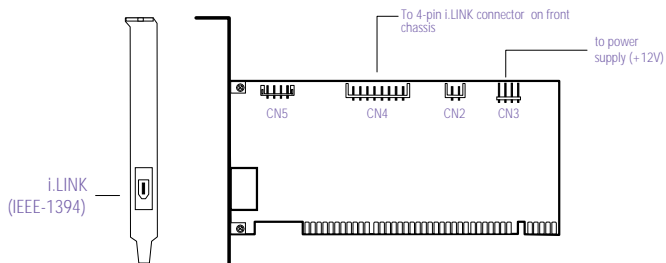

KY0088.1

Chapter 7

CMOS Setup Options

This chapter describes each screen in the PhoenixBIOS Setup Utility (see “Accessing the BIOS Setup Utility” on page 16).

The Award BIOS setup has five menu items on the menu bar. These are:

- ❑ Main
- ❑ Advanced
- ❑ Power
- ❑ Boot
- ❑ Exit

Options that you can change are enclosed in brackets. Text that is not enclosed in brackets cannot be changed.

A small triangle (▶) indicates that there is a sub-menu with additional information and options. Press Enter to display the sub-menu. The information and options in a sub-menu are context-sensitive (they appear or disappear, depending on which options you select).

The item shown in [brackets] in this guide is the default option. The option shown in [brackets] on the screen is the option currently set for your system.

The other available options for each item are shown without brackets directly below the default option in this guide. The available options are listed in the order they occur when you press the + key.

Use the left and right arrow keys to choose a menu item. Use the up and down arrow keys to select an option. Press Enter to display a list of options, or press the + or - key to cycle through the other options.

If you display the list of options, use the up and down arrow keys to select an option in the list, then press Enter to choose the selection.

Press Esc to go back to the main menu.

Press F10 to save the changes and exit, or press Esc to discard the changes.

Follow the on-screen prompts for other choices. The bottom of the screen presents a summary of the keys to use for navigation and control.

Main Screen

System Time	[00:00:00]
System Date	[01/01/1999]
Legacy Diskette A	[1.44M, 3.5 in.] 2.88M, 3.5 in. None 360K, 5.25 in. 1.2M, 5.25 in. 720K, 3.5 in.
Legacy Diskette B	[None] 360K, 5.25 in. 1.2M, 5.25 in. 720K, 3.5 in. 1.44M, 3.5 in. 2.88M, 3.5 in.
Floppy 3 Mode Support	[Disabled] Drive A Drive B Both
▶Primary Master (see “IDE Sub-Menus” on page 78)	
▶Primary Slave (see “IDE Sub-Menus” on page 78)	
▶Secondary Master (see “IDE Sub-Menus” on page 78)	
▶Secondary Slave (see “IDE Sub-Menus” on page 78)	
Language	[English]
Supervisor Password	[Disabled]
User Password	[Disabled]
Halt On	[All but Keyboard] All but Disk All but Disk/Keyboard All Errors No Error
Installed Memory	63 MB

▶IDE Sub-Menus

Type	[Auto] User Type HDD CD-ROM LS-120 ZIP-100 MO Other ATAPI None
Translation Method*	[LBA] Large Normal Match Partition Table Manual
Cylinders [†]	[1024]
Heads [†]	[255]
Sectors [‡]	[63]
CHS Capacity*	8422MB
Maximum LBA Capacity*	10262MB
Multi-Sector Transfers*	[Maximum] Disabled 2 Sectors 4 Sectors 8 Sectors 16 Sectors 32 Sectors
SMART Monitoring*	[Disabled] Enabled
PIO Mode**	[4]
ULTRA DMA Mode [†]	[2]
Set Device As ^{††}	[Auto] Floppy Hard Disk

* This option appears when Type is set to User Type HDD.

† This option appears when Type is set to Auto or User Type HDD.

‡ This option appears when Type is set to Auto or User Type HDD.

** This option appears when Type is not set to None.

†† This option appears when Type is set to ZIP-100 or MO.

Advanced Screen

CPU Core:Bus Freq. Multiplier	[2.0x] 2.5x 3.0x 3.5x 4.0x 4.5x 5.0x 5.5x 6.0x 6.5x 7.0x 7.5x 8.0x
CPU Level 1 Cache	[Enabled] Disabled
CPU Level 2 Cache	[Enabled] Disabled
CPU Level 2 Cache ECC Check	[Disabled] Enabled
BIOS Update	[Enabled] Disabled
PS/2 Mouse Function Control	[Auto] Enabled
USB Legacy Support	[Auto] Disabled Enabled
OS/2 Onboard Memory > 64M	[Disabled] Enabled
Volume	[MEDIUM] HIGH MUTE LOW

- ▶ Chip Configuration (see “[Chip Configuration Sub-Menu](#)” on page 80)
- ▶ I/O Device Configuration (see “[I/O Device Configuration Sub-Menu](#)” on page 81)
- ▶ PCI Configuration (see “[PCI Configuration Sub-Menu](#)” on page 82)
- ▶ Shadow Configuration (see “[Shadow Configuration Sub-Menu](#)” on page 84)

► Chip Configuration Sub-Menu

SDRAM Configuration	[By SPD] User Define 7ns (143MHz) 8ns (125MHz)
SDRAM CAS Latency	[2T]
SDRAM RAS to CAS Delay	[2T]
SDRAM RAS Precharge Time	[2T]
SDRAM Cycle Time (Tras, Trc)	[5T, 7T] 6T, 8T
SDRAM Address Setup Time	[1T Delay] No Delay
SDRAM Page Closing Policy	[All Banks] One Bank
CPU Latency Timer	[Enabled] Disabled
Onboard VGA	[Enabled] Disabled
Display Cache Paging Mode	[Page Open] Page Close
Video Memory Cache Mode	[UC] USWC
Memory Hole At 15M-16M	[Disabled] Enabled
PCI 2.1 Support	[Enabled] Disabled
High Priority PCI Mode	[Enabled] Disabled
Onboard PCI IDE Enable	[Both] Primary Secondary Disabled

▶I/O Device Configuration Sub-Menu

Onboard AC97 Audio Controller	[Auto] Disabled
Onboard FDC Swap A & B	[No Swap] Swap AB
Floppy Disk Access Control	[R/W] Read Only
Onboard Serial Port 1	[3F8H/IRQ4] 2F8H/IRQ3 3E8H/IRQ4 2E8H/IRQ10 Disabled
Onboard Parallel Port	[378H/IRQ7] 278H/IRQ5 Disabled 3BCH/IRQ7
Parallel Port Mode	[Normal] EPP ECP ECP+EPP
Onboard Game Port	[Disabled] 200H-207H 208H-20FH

▶ PCI Configuration Sub-Menu

Slot 1 IRQ to Slot 4 IRQ	[Auto] NA 3 4 5 7 9 10 11 12 14 15
PCI/VGA Palette Snoop	[Disabled] Enabled
PCI Latency Timer	[32]
SYMBIOS SCSI BIOS	[Auto] Disabled
USB Function	[Enabled] Disabled
ONB VGA BIOS First	[No] Yes
Onboard Audio	[Enabled] Disabled

▶ PCI/PNP ISA IRQ Resource Exclusion

(see “PCI/PNP ISA IRQ Resource Exclusion Sub-Menu” on page 83)

▶ PCI/PNP ISA DMA Resource Exclusion

(see “PCI/PNP ISA DMA Resource Exclusion Sub-Menu” on page 83)

▶ PCI/PNP ISA UMB Resource Exclusion

(see “PCI/PNP ISA UMB Resource Exclusion Sub-Menu” on page 83)

▶ PCI/PNP ISA IRQ Resource Exclusion Sub-Menu

IRQ 3 Used By ISA	[No/ICU] Yes
IRQ 4 Used By ISA	[No/ICU] Yes
IRQ 5 Used By ISA	[Yes] No/ICU
IRQ 7 Used By ISA	[No/ICU] Yes
IRQ 9 Used By ISA	[No/ICU] Yes
IRQ 10 Used By ISA	[No/ICU] Yes
IRQ 11 Used By ISA	[No/ICU] Yes
IRQ 12 Used By ISA	[No/ICU] Yes
IRQ 14 Used By ISA	[No/ICU] Yes
IRQ 15 Used By ISA	[No/ICU] Yes

▶ PCI/PNP ISA DMA Resource Exclusion Sub-Menu

DMA 1 Used By ISA	[No/ICU] Yes
DMA 2 Used By ISA	[No/ICU] Yes
DMA 3 Used By ISA	[No/ICU] Yes

▶ PCI/PNP ISA UMB Resource Exclusion Sub-Menu

ISA MEM Block BASE	[No/ICU] C800 CC00 D000 D400 D800 DC00
--------------------	--

▶ Shadow Configuration Sub-Menu

Video ROM BIOS Shadow	[Enabled] Disabled
D0000-D7FFF Shadow	[Disabled] Enabled
D8000-DBFFF Shadow	[Disabled] Enabled
DC000-DFFFF Shadow	[Disabled] Enabled

Power Screen

Power Management	[User Define] Disabled Min Saving Max Saving
Video Off Option	[Suspend -> Off] Always On
Video Method	[DPMS OFF] DPMS Reduce ON Blank Screen V/H SYNC+Blank DPMS Standby DPMS Suspend
HDD Power Down	[Disabled] 1 Min 2 Min 3 Min 4 Min 5 Min 6 Min 7 Min 8 Min 9 Min 10 Min 11 Min 12 Min 13 Min 14 Min 15 Min
ACPI Mode	[S1] S3
Suspend Mode	[Disabled] 1~2 Min 2~3 Min 4~5 Min 8~9 Min 20 Min 30 Min 40 Min 1 Hour
PWR Button < 4 Secs	[Suspend] Soft Off

▶ Power Up Control (see “Power Up Control Sub-Menu” on page 86)

▶ Hardware Monitor (see “Hardware Monitor Sub-Menu” on page 86)

▶Power Up Control Sub-Menu

AC PWR Loss Restart	[Disabled] Enabled
PWR Up On Modem Act	[Disabled] Enabled
Wake On LAN	[Disabled] Enabled

▶Hardware Monitor Sub-Menu

MB Temperature	[Ignore] (displays actual temperature)
CPU Temperature	[(displays actual temperature)] Ignore
CPU Fan Speed	[Ignore] N/A
Power Fan Speed	[(displays actual RPM)] Ignore
Chassis Fan Speed	N/A
VCORE Voltage	[(displays actual voltage)] Ignore
+3.3V Voltage	[(displays actual voltage)] Ignore
+5V Voltage	[(displays actual voltage)] Ignore
+12V Voltage	[(displays actual voltage)] Ignore
-12V Voltage	[(displays actual voltage)] Ignore
-5V Voltage	[(displays actual voltage)] Ignore

Boot Screen

1. ATAPI CD-ROM	[(displays installed drive)] Disabled
2. Removable Device	[Legacy Floppy] LS120 ZIP-100 ATAPI MO Disabled
3. IDE Hard Drive	[(displays installed drive)] Disabled
4. Other Boot Device	[Disabled] Network SCSI Boot Device
Plug & Play O/S	[No] Yes
Boot Virus Detection	[Enabled] Disabled
Quick Power On Self Test	[Enabled] Disabled
Boot Up Floppy Seek	[Disabled] Enabled
Boot Up Num Lock Status	[On] Off
Silent Boot	[Enabled] Disabled
BOOT Sound	[Enabled] Disabled

Exit Screen

Exit Saving Changes

Exit Discarding Changes

Load Setup Defaults

Discard Changes

Save Changes

Chapter 8

Miscellaneous Technical Information

This chapter contains information on the following subjects:

- ❑ User and Supervisor password
- ❑ Beep code error messages
- ❑ PCI configuration status and error messages
- ❑ DMA channel assignments
- ❑ IRQ assignments
- ❑ System I/O address map
- ❑ Memory map
- ❑ PCI configuration space map

About User and Supervisor Passwords

The system allows you to specify up to two passwords (a User password and a Supervisor password) in the CMOS Setup Utility. The User password is required; the Supervisor password is optional.

Access to the CMOS Setup Utility depends on which passwords were previously set, as indicated next.

<i>If you set these passwords...</i>	<i>...the following passwords are required:</i>
User password only	User password is required at bootup.
Supervisor password only	No password is required at bootup. Supervisor password is required by most setup options.
Both passwords	User password is required at bootup. Supervisor password is required by most setup options.

Beep Code Error Messages

During a normal bootup, a single short beep signifies that the system is OK. Other beep patterns signify errors. The number of beeps indicates the specific error that occurred.

The Sony Online Support technical representative will need to know how many beeps your system produces if there is an error, so be sure to count the number of beeps before calling for support.

PCI Configuration Status and Error Messages

The following is a list of status and error messages that may appear on your system from time to time.

<i>Message</i>	<i>Meaning</i>
Floppy Disk Controller Resource Conflict	The diskette controller has requested a resource that is already in use.
CMOS Checksum Error, CMOS Cleared	The CMOS data was reinitialized due to a CMOS checksum error.
CMOS Data Invalid, CMOS Cleared	Invalid entry in the CMOS.
Parallel Port Resource Conflict	The parallel port has requested a resource that is already in use.
PCI Error Log is Full	This message is displayed when more than 15 PCI conflict errors are detected. No additional PCI errors can be logged.
PCI I/O Port Conflict	Two devices requested the same resource, resulting in a conflict.
PCI IRQ Conflict	Two devices requested the same resource, resulting in a conflict.
PCI Memory Conflict	Two devices requested the same resource, resulting in a conflict.
Primary Boot Device Not Found	The designated primary boot device (hard disk drive, diskette drive, CD-ROM drive, or network drive) could not be found.
Primary IDE Controller Resource Conflict	The primary IDE controller has requested a resource that is already in use.
Primary Input Device Not Found	The designated primary input device (keyboard, mouse, or other, if input is redirected) could not be found.
Primary Output Device Not Found	The designated primary output device (display, serial port, or other, if input is redirected) could not be found.
Secondary IDE Controller Resource Conflict	The secondary IDE controller has requested a resource that is already in use.
Serial Port 1 Resource Conflict	Serial port 1 has requested a resource that is already in use.
Static Device Resource Conflict	A non-Plug and Play ISA card has requested a resource that is already in use.

System Board Device Resource
Conflict

A non-Plug and-Play ISA card has
requested a resource that is already in use.

DMA Channel Assignments

This shows the factory default values. The Microsoft® Windows® 98 Second Edition operating system reassigns resources to best meet the needs of a particular configuration.

<i>DMA Channel</i>	<i>Default Assignment</i>
1	Vortex AU8810 Sound Blaster Pro emulation
2	Standard diskette controller
3	ECP printer port (LPT1)/Vortex AU8810 Sound Blaster Pro emulation
4	Direct memory access controller

System I/O Address Map

<i>Address Range (hex)</i>	<i>Description</i>
0000 - 000F	Direct memory access controller
0010 - 001F	Motherboard resources
0020 - 0021	Programmable interrupt controller
0022 - 002D	Motherboard resources
002E - 002F	Motherboard resources
0030 - 003F	Motherboard resources
0040 - 0043	System timer
0044 - 005F	Motherboard resources
0060 - 0060	Standard 101/102-Key or Microsoft Natural Keyboard controller
0061 - 0061	System speaker
0062 - 0063	Motherboard resources
0064 - 0064	Standard 101/102-Key or Microsoft Natural Keyboard controller
0065 - 006F	Motherboard resources
0070 - 0073	System CMOS/real-time clock
0074 - 007F	Motherboard resources
0080 - 0090	Direct memory access controller
0091 - 0093	Motherboard resources
0094 - 009F	Direct memory access controller
00A0 - 00A1	Programmable interrupt controller
00A2 - 00BF	Motherboard resources
00C0 - 00DF	Direct memory access controller
00E0 - 00EF	Motherboard resources
00F0 - 00FF	Numeric data processor
0170 - 0177	Intel 82801AA bus master IDE controller
0170 - 0177	Secondary IDE controller (dual FIFO)
01F0 - 01F7	Intel 82801AA bus master IDE controller
01F0 - 01F7	Primary IDE controller (dual FIFO)
0201 - 0201	Vortex AU8810 gameport interface
0220 - 022F	Vortex AU8810 Sound Blaster Pro emulation
0290 - 0297	Motherboard resources
0330 - 033F	Vortex AU8810 MPU-401 interface

<i>Address Range (hex)</i>	<i>Description</i>
0376 - 0376	Intel 82801AA bus master IDE controller
0376 - 0376	Secondary IDE controller
0378 - 037F	ECP printer port (LPT1)
0388 - 0388	Vortex AU8810 Sound Blaster Pro emulation
03B0 - 03BB	Intel® 810 chipset graphics driver PV2.2
03C0 - 03DF	Intel® 810 chipset graphics driver PV2.2
03F0 - 03F1	Motherboard resources
03F2 - 03F5	Standard diskette controller
03F6 - 03F6	Intel 82801AA bus master IDE controller
03F6 - 03F6	Primary IDE controller (dual FIFO)
03F7 - 03F7	Standart diskette controller
03F8 - 03FF	Communication port (COM1)
04D0 - 04D1	Motherboard resources
0778 - 077A	ECP printer port (LPT1)
0CF8 - 0CFF	PCI bus
A400 - A41F	Intel 82801AA USB universal host controller
A800 - A80F	Intel 82801AA bus master IDE controller
A808 - A80F	Secondary IDE controller (dual FIFO)
B000 - DFFF	Intel 82801AA PCI bridge
B800 - B8FF	LT WinModem
D000 - D007	LT WinModem
D400 - D407	Vortex AU8810 multifunction PCI platform
D400 - D407	Vortex AU8810 PCI audio
D800 - D807	Vortex AU8810 multifunction PCI platform
D800 - D807	Vortex AU8810 PCI audio
E400 - E47F	Motherboard resources
E800 - E80F	Intel® 82801AA SMBus controller
EC00 - EC3F	Motherboard resources



I/O addresses that may be used by add-in cards are not listed.

Memory Map

<i>Address range</i>	<i>Default configuration</i>
00000000 - 0009FFFF	System board extension for ACPI BIOS
000A0000 - 000AFFFF	Intel® 810 chipset graphics driver PV2.2
000B0000 - 000BFFFF	Intel® 810 chipset graphics driver PV2.2
000F0000 - 000FFFFF	System board extension for ACPI BIOS
00100000 - 03FFFFFF	System board extension for ACPI BIOS
E1800000 - E37FFFFF	Intel 82801AA PCI bridge
E3000000 - E303FFFF	Vortex AU8810 multifunction PCI platform
E3000000 - E303FFFF	Vortex AU8810 PCI audio
E3800000 - E387FFFF	Intel® 810 chipset graphics driver PV2.2
E4000000 - E7FFFFFF	Intel® 810 chipset graphics driver PV2.2
FFB80000 - FFBFFFFF	Intel® 82802 firmware hub device
FFF80000 - FFFFFFFF	Intel® 82802 firmware hub device

IRQ Settings

<i>IRQ</i>	<i>Settings</i>
00	System timer
01	Standard 101/102-Key or Microsoft Natural Keyboard
02	Programmable interrupt controller
03	Sony OHCI i.LINK [®] (IEEE-1394) PCI host controller
03	Vortex AU8810 multifunction PCI platform
03	Vortex AU8810 PCI audio
03	ACPI IRQ holder for PCI IRQ steering
04	Communications port (COM1)
05	Vortex AU8810 Sound Blaster Pro emulation
06	Standard diskette controller
07	Printer port (LPT1)
08	System CMOS/real-time clock
09	Intel 82801AA USB universal host controller
09	LT WinModem
09	ACPI IRQ holder for PCI IRQ steering
09	SCI IRQ used by ACPI bus
10	Intel [®] 82801AA SMBus controller
10	ACPI IRQ holder for PCI IRQ steering
11	Intel [®] 810 chipset graphics driver PV2.2
11	ACPI IRQ holder for PCI IRQ steering
12	WheelMouse (PS/2)
13	Numeric data processor
14	Intel 82801AA bus master IDE controller
14	Primary IDE controller (dual FIFO)
15	Intel 82801AA bus master IDE controller
15	Secondary IDE controller (dual FIFO)

Chapter 9

Specifications

This chapter describes the technical specifications for the Sony PCV-R532DS computer.

Processor

466 MHz* Intel Celeron processor (with 66 MHz FSB)

* MHz denotes microprocessor internal clock speed. Other factors may affect application performance.

Chipset

Intel® 810

PCI Bus

PCI Level 2.2, 33 MHz zero wait state

4 PCI slots (2 open)

Memory Modules (DIMMs)

Installed memory	64 Mbytes PC-100 SDRAM (100 MHz)
------------------	----------------------------------

Maximum memory	256 Mbytes (128Mbytes in each socket)
----------------	---------------------------------------

Voltage	3.3 V memory only
---------	-------------------

Pins	168-pins with gold-plated contacts
------	------------------------------------

SDRAM type	PC-100, 60 ns, unrestricted CAS latency 2, unbuffered, Intel 4-clock, 64 bits (non-ECC)
------------	---

DIMM Configurations

<i>DIMM1*</i>	<i>DIMM2*</i>
0, 8, 16, 32, 64, 128	0, 8, 16, 32, 64, 128

* The PCV-R532DS is shipped with 64 MB. SDRAM is expandable to 256 MB. Computer SDRAM is unbuffered DIMM, specification Rev. 1.0 or later. Supports SDRAM memory. Does not support EDO memory or buffered DIMM memory. Memory can be installed in either socket. Memory size can vary between sockets. DIMMs can be single- or double-sided. DIMMs must be 3.3V unbuffered 4-clock, 64-bit or 72-bit 100 MHz SDRAM module.

L2 Cache

Installed	128 kbytes secondary write-back cache (in processor), direct-mapped organization, on-chip cache
-----------	---

Graphics

Chipset	Intel 810
Video memory	Shared with system memory
Resolution (displayed resolution depends on the video monitor you use)	
True color (24 bits)	Up to 1280 x 1024 at 85 Hz non-interlaced
High color (16 bits)	Up to 1280 x 1024 at 85 Hz non-interlaced
256 colors (8 bits)	Up to 1600 x 1200 at 75 Hz non-interlaced

Audio

Sound chip	Aureal 8810 plus AC97 codec
Wave synthesis	Aureal wavetable synthesis
Sound effects	A3D stereo
Audio sampling rate	Up to 48 kHz at 16 bits
Rear panel connectors	MIC (for microphone) LINE IN (from stereo audio source) HEADPHONES (for stereo headphones)

Communications

Modem	V.90-compatible data/fax modem *
Fax	14.4 kbps maximum
i.LINK® (IEEE-1394)	400 Mbps, OHCI chipset

* Due to FCC limitations, the maximum permissible data speed is 53 kbps during download transmissions. Actual data speeds may vary, depending on line conditions.

I/O and Expansion Slots

Serial ports	One high-speed NS16C550-compatible port
Parallel port	One high-speed bi-directional Centronics-compatible port with ECP and EPP modes
Game/MIDI port	One (supports MIDI in/out or two joysticks — adapter cable not supplied)
Modem ports	Two RJ-11 connectors (for line and phone)
USB ports	USB1 (on front panel) USB2 (on rear panel)
PCI slots	Two available slots. Maximum length for add-in cards is 7.75 inches
IDE connectors	Primary and secondary (each supports two IDE drives)
i.LINK (IEEE-1394) ports	One 4-pin connector on front panel One 6-pin connector on rear panel

Drives and Controllers

Diskette controller	765A-compatible (supports up to 2.88 MByte)
Diskette drive	1.44 MByte 3.5-inch MFDD
EIDE controller	Supports up to four EIDE drives (supports PIO Mode 4 EIDE drives and Ultra DMA/33 Mode drives)*
IDE hard drive†	10.2 GByte‡
DVD-ROM drive**	DVD-ROM: 8X (maximum performance). CD-ROM: 40X (maximum performance).

* Controller is ready to support ATA-66 drives by utilizing ATA-66-compliant interface cables and hard drives.

† Bus-mastering EIDE driver installed.

‡ GB means one billion bytes when referring to hard drive capacity. Accessible capacity may vary.

**Data on a DVD-ROM is read at a variable transfer rate, ranging from 3.3X at the innermost track to 8X at the outermost track (the data transfer standard 1X rate is 1385 kbytes/s). The average data transfer rate is 5.6X (7634 kbytes/s). Data on a CD-ROM is read at a variable transfer rate, ranging from 17.2X at the innermost track to 40X at the outermost track (the data transfer standard 1X rate is 150 kbytes/s). The average data transfer rate is 28.6X (4293 kbytes/s)

System BIOS

Make and model	Award-based
ROM	4 Mbit flash-ROM
Passwords	User and supervisor passwords supported
Recovery boot block	Supported
Power management	APM 1.2
Advanced features	ACPI-1.0 compliant hardware for use with APM and PNP BIOS APIs
Plug and Play devices	Supported with steerable DMA channels and interrupts
Special features	PC-98 ready, multi-boot, PCI add-in card auto-configure

Index

A

- add-in card
 - installing 28
 - removing 29
- address map, system 95
- audio specifications 101
- AUX-IN connector 69

B

- battery - See lithium battery
- beep codes 91
- BIOS Setup Utility 16
- BIOS setup utility 16
 - advanced screen 79
 - boot screen 87
 - exit screen 88
 - main screen 77
 - options 75
 - power screen 85
 - screens 75
- BIOS specifications 102

C

- card, modem 71
- CD-IN connector 67
- CD-ROM disc - See DVD-ROM drive
- CD-RW drive
 - location of 3
 - performance of discs 102
 - specifications 102
- CMOS - See Also BIOS
- CMOS Clear configuration jumper 70
- codes, beeps 91
- COM1 port - See SERIAL connector
- communications, specifications 101

- computer safety information ii
- configuration jumper, CMOS Clear 70
- configuring
 - BIOS setup utility 16
 - power management 17
 - system board 19
- connectors
 - 4-pin on modem card 71
 - AUX-IN 69
 - CD-IN 67
 - fan 64
 - GAME 65
 - i.LINK 6
 - IDE 58
 - KEYBOARD 59
 - LINE 71
 - Modem 68
 - modem card 71
 - MONITOR 61
 - MOUSE 59
 - on i.LINK card 73
 - power 58
 - PRINTER 61
 - TELEPHONE 71
 - USB 6, 60
- cover 26
 - removing 22
 - slot 39
- covering I/O slot 40
- CPU - See processor

D

- DIMM - See memory module
- diskette drive
 - connector 55

display, power management 17
DMA channel assignments 94
drive
 CD-RW specifications 102
 IDE connectors 58
 installing an additional 3½" drive 41
 installing an additional 3½" or 5¼" drive 45
 specifications 102
DVD-ROM drive
 performance of discs 3, 102
 plays CD-ROMs 102

E

error messages
 beep codes 91
 PCI configuration 92
expansion slots 14
 specifications for 101
expansion slots - See Also slots

F

fan connectors 64
 CPU-FAN 64
 PWR-FAN 64
fax card - See modem card
fax/modem - See Also communications
FCC Part 68 iv
front panel
 removing 24
 replacing 25
front panel header 54
front view 2
 buttons and switches 4
 connectors 5, 6
 drives 3
 indicators 5

G

GAME connector 12, 65
graphics controller - See graphics
graphics specifications 100

H

header - See front panel header
HEADPHONES connector 12, 66

I

i.LINK card 73
i.LINK connector 6
I/O address map 95
I/O connectors
 GAME 12
 HEADPHONES 12, 66
 i.LINK 13
 KEYBOARD 10
 LINE 13
 LINE IN 12, 66
 MIC 12, 66
 MONITOR 11
 MOUSE 10
 PRINTER 11
 SERIAL 10
 TELEPHONE 13
 USB 10, 60
I/O slot covering 40
I/O slot specifications 101
icons, description of 8
IDE
 connectors 58
 specifications 102
IEEE-1394 - See i.LINK
input devices iii
installing
 3½" hard disk drive 41
 3½" or 5¼" hard disk drive 45
 add-in card 28
 system memory 34
interference iii
IRQ settings 98

J

jumper - See system board

K

KEYBOARD connector 10, 59

L

L2 cache specifications 100
 LINE connector 13
 LINE IN connector 12, 66
 lithium battery, replacing 31

M

map - See Also I/O address map and memory map
 memory - See Also system memory
 memory module
 connector 56
 removing 37
 specifications 99
 messages
 error 91
 status and error 92
 MIC connector 12, 66
 microprocessor - See processor
 model numbers ii
 modem - See Also communications
 modem card 71
 connectors 71
 view of 71
 Modem connector 68
 monitor - See display
 MONITOR connector 11, 61
 MOUSE connector 10, 59

N

notice to users ii

O

output devices iii

P

panel, front 24, 25
 passwords, user and supervisor 90
 PCI
 slot connectors 57
 power connector 58
 power management, configuring 17
 PRINTER connector 11, 61
 processor specifications 99

R

radio interference iii
 RAM - See Also system memory
 rear view 7
 I/O connectors 10
 icons 8
 recording ii
 regulatory information iii
 removing
 add-in card 29
 cover 22
 front panel 24
 memory module 37
 slot cover 39
 replacing 26
 cover 26
 front panel 25
 replacing lithium battery 31
 resolution - See graphics

S

safety information ii
 SERIAL 1 connector 61
 SERIAL connector 10
 serial numbers ii
 serial port - See SERIAL 1
 setup, BIOS 16
 slot - See Also I/O slot
 slot cover, removing 39
 specifications
 audio 101
 BIOS 102
 communications 101
 drives and controllers 102
 graphics 100
 I/O and expansion slots 101
 L2 cache 100
 memory module 99
 processor 99
 status and error messages 92
 supervisor password 90
 system board
 AUX-IN connector 69
 CD-IN connector 67
 configuration jumper 70

configuring **19**
diskette drive connector **55**
fan connectors **64**
front panel header **54**
GAME connector **65**
HEADPHONES connector **66**
IDE connectors **58**
KEYBOARD connector **59**
LINE IN connector **66**
memory module connector **56**
MIC connector **66**
Modem connector **68**
MONITOR connector **61**
MOUSE **59**
PCI slot connectors **57**
power connector **58**

PRINTER connector **61**
SERIAL 1 connector **61**
USB connectors **60**
system I/O address map **95**
system memory, installing **34**

T

TELEPHONE connector **13**
Telephone Consumer Protection Act of
1991 **iv**
TV interference **iii**

U

USB connectors **6, 10, 60**
user password **90**