

# **OPERATOR'S MANUAL**

## **ECONOMY PUSH ROTARY Lawn Mower**

- **Assembly**
  - **Operation**
    - **Maintenance**
      - **Service and Adjustments**
      - **Storage**
      - **Troubleshooting**

# TABLE OF CONTENTS

Safety Rules .....	2	Service and Adjustments.....	21
Assembly .....	9	Storage .....	22
Operation.....	16	Troubleshooting .....	23
Maintenance .....	19		

## SAFETY RULES

**IMPORTANT:** This cutting machine is capable of amputating hands and feet and throwing objects. Failure to observe the following safety instructions could result in serious injury or death.

**⚠** Look for this symbol to point out important safety precautions. It means **CAUTION!!! BECOME ALERT!!! YOUR SAFETY IS INVOLVED.**

**⚠ WARNING:** In order to prevent accidental starting when setting up, transporting, adjusting or making repairs, always disconnect spark plug wire and place wire where it cannot contact plug.

**⚠ WARNING:** Engine exhaust, some of its constituents, and certain vehicle components contain or emit chemicals known to the State of California to cause cancer and birth defects or other reproductive harm.

**⚠ WARNING:** Battery posts, terminals and related accessories contain lead and lead compounds, chemicals known to the State of California to cause cancer and birth defects or other reproductive harm. **Wash hands after handling.**

**⚠ CAUTION:** Muffler and other engine parts become extremely hot during operation and remain hot after engine has stopped. To avoid severe burns on contact, stay away from these areas.

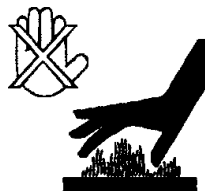

### I. GENERAL OPERATION

- Read, understand, and follow all instructions on the machine and in the manual(s) before starting. Be thoroughly familiar with the controls and the proper use of the machine before starting.
- Do not put hands or feet near or under rotating parts. Keep clear of the discharge opening at all times.
- Only allow responsible individuals, who are familiar with the instructions, to operate the machine.
- Clear the area of objects such as rocks, toys, wire, bones, sticks, etc., which could be picked up and thrown by the blade.
- Be sure the area is clear of other people before mowing. Stop machine if anyone enters the area.
- Do not operate the mower when barefoot or wearing open sandals. Always wear substantial foot wear.
- Do not pull mower backwards unless absolutely necessary. Always look down and behind before and while moving backwards.
- Do not operate the mower without proper guards, plates, grass catcher or other safety protective devices in place.
- See manufacturer's instructions for proper operation and installation of accessories. Only use accessories approved by the manufacturer.
- Stop the blade(s) when crossing gravel drives, walks, or roads.
- Stop the engine (motor) whenever you leave the equipment, before cleaning the mower or unclogging the chute.

- Shut the engine (motor) off and wait until the blade comes to complete stop before removing grass catcher.
- Mow only in daylight or good artificial light.
- Do not operate the machine while under the influence of alcohol or drugs.
- Never operate machine in wet grass. Always be sure of your footing: keep a firm hold on the handle and walk; never run.
- Disengage the self-propelled mechanism or drive clutch on mowers so equipped before starting the engine (motor).
- If the equipment should start to vibrate abnormally, stop the engine (motor) and check immediately for the cause. Vibration is generally a warning of trouble.
- Always wear safety goggles or safety glasses with side shields when operating mower.

## II. SLOPE OPERATION

Slopes are a major factor related to slip and fall accidents which can result in severe injury. All slopes require extra caution. If you feel uneasy on a slope, do not mow it.

### DO:

- Mow across the face of slopes: never up and down. Exercise extreme caution when changing direction on slopes.
- Remove obstacles such as rocks, tree limbs, etc.
- Watch for holes, ruts, or bumps. Tall grass can hide obstacles.

### DO NOT:

- Do not trim near drop-offs, ditches or embankments. The operator could lose footing or balance.
- Do not trim excessively steep slopes.
- Do not mow on wet grass. Reduced footing could cause slipping.

## III. CHILDREN

Tragic accidents can occur if the operator is not alert to the presence of children. Children are often attracted to the machine and the mowing activity. *Never* assume that children will remain where you last saw them.

- Keep children out of the trimming area and under the watchful care of another responsible adult.

- Be alert and turn machine off if children enter the area.
- Before and while walking backwards, look behind and *down* for small children.
- Never allow children to operate the machine.
- Use extra care when approaching blind corners, shrubs, trees, or other objects that may obscure vision.

## IV. SERVICE

- Use extra care in handling gasoline and other fuels. They are flammable and vapors are explosive.
  - Use only an approved container.
  - Never remove gas cap or add fuel with the engine running. Allow engine to cool before refueling. Do not smoke.
  - Never refuel the machine indoors.
  - Never store the machine or fuel container inside where there is an open flame, such as a water heater.
- Never run machine inside a closed area.
- Never make adjustments or repairs with the engine (motor) running. Disconnect the spark plug wire, and keep the wire away from the plug to prevent accidental starting.
- Keep nuts and bolts, especially blade attachment bolts, tight and keep equipment in good condition.
- Never tamper with safety devices. Check their proper operation regularly.
- Keep machine free of grass, leaves, or other debris build-up. Clean oil or fuel spillage. Allow machine to cool before storing.
- Stop and inspect the equipment if you strike an object. Repair, if necessary, before restarting.
- Never attempt to make wheel height adjustments while the engine (motor) is running.
- Grass catcher components are subject to wear, damage, and deterioration, which could expose moving parts or allow objects to be thrown. Frequently check components and replace with manufacturer's recommended parts, when necessary.
- Mower blades are sharp and can cut. Wrap the blade(s) or wear gloves, and use extra caution when servicing them.
- Do not change the engine governor setting or overspeed the engine.

**CONGRATULATIONS** on your purchase of a new Lawn Mower. It has been designed, engineered and manufactured to give you the best possible dependability and performance.

Should you experience any problems you cannot easily remedy, please contact your nearest authorized service center. They have competent, well trained technicians and the proper tools to service or repair this unit.

- Read the SAFETY RULES and this Operator's Manual in its entirety before you attempt to assemble or operate your new lawn mower to insure proper operation and to prevent injury to yourself and others. Save this manual for future reference.
- Your new lawn mower has been assembled at the factory with the exception of those parts left unassembled for shipping purposes. To ensure safe and proper operation of your lawn mower, all parts and hardware you assemble must be tightened securely. Use the correct tools as necessary to ensure proper tightness.
- All parts such as nuts, washers, bolts, etc., necessary to complete the assembly have been placed in the parts bag.

## TO REMOVE MOWER FROM CARTON

- Remove all loose parts from carton.
- Remove lawn mower housing with care. Avoid touching blade under housing. Always wear gloves or other protection when working under or lifting mower.

## THINGS TO KNOW BEFORE YOU ASSEMBLE OR OPERATE YOUR LAWN MOWER

### *Do I have a side or rear discharge lawn mower?*

Look for the grass discharge opening on your mower. If the opening is on the right side of the mower housing, it is a side discharge mower. If the opening is at the back of the mower housing, it is a rear discharge mower. Only rear discharge lawn mowers have a grass catcher included with the mower. Approved grass catchers for side discharge mowers may be purchased from your nearest authorized dealer.

### *Do I have a mulching lawn mower?*

Look for the grass discharge opening on your mower. Raise the discharge guard (rear door on rear discharge mowers). If the opening is closed off by a plate, then your lawn mower is mulcher ready. To convert to a discharging mower, see the Operation section of this manual.

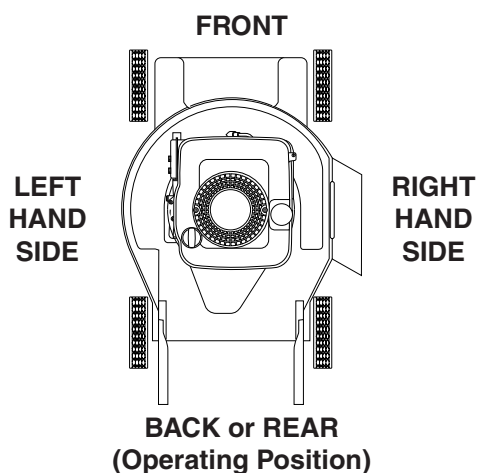

### *What is the right and left side of the lawn mower?*

When right hand (RH) or left hand (LH) is mentioned in this manual, it means when you are in the operating position (standing behind the handle).

### *What kind of engine is on my lawn mower?*

When learning how to operate your new lawn mower, you will need to know what kind of engine powers the mower. A decal on the engine will indicate the manufacturer and type or brand name of the engine.

#### BRIGGS & STRATTON ENGINES

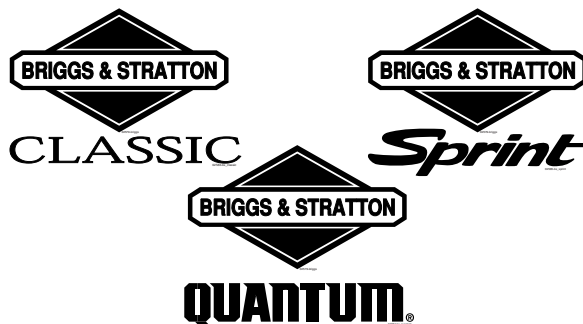

#### TECUMSEH ENGINES



#### HONDA ENGINES



**NOTE:** Depending upon the features on the lawn mower model you purchased, all the parts shown may not be included with your mower. For ease of assembly, aside of your work area, lay out all hardware in the groups shown. Each step of the assembly instructions will identify the group needed for that step.

## PARTS PACKED SEPARATELY IN CARTON

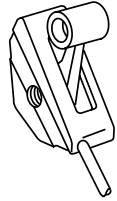
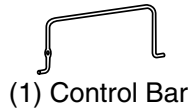

**NOTE:** Some model lawn mowers already have the wheels preassembled to the mower.

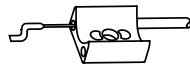
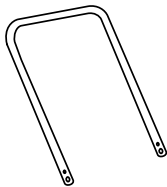
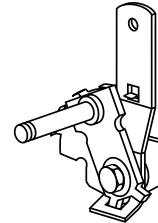
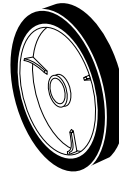
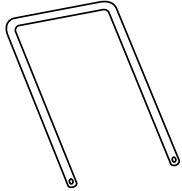

(1) Discharge Guard  
(Side Discharge models only)

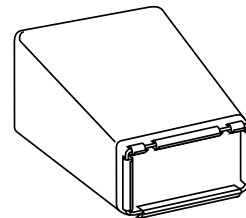
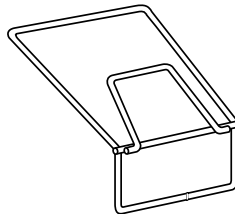
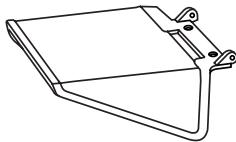



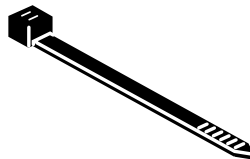
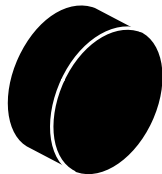

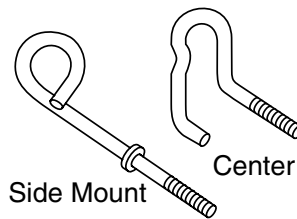

## PARTS BAG CONTENTS NOT SHOWN ACTUAL SIZE

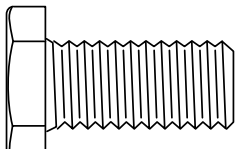
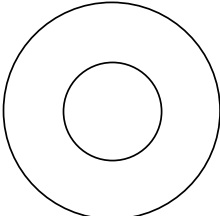
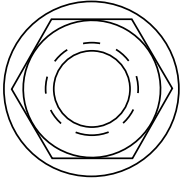
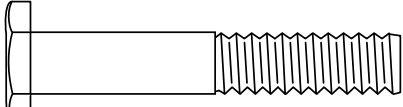
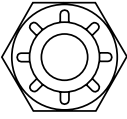
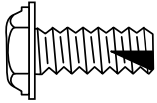
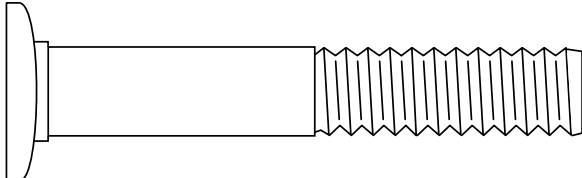
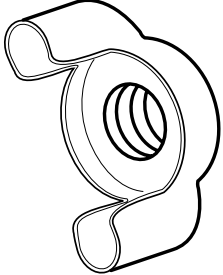

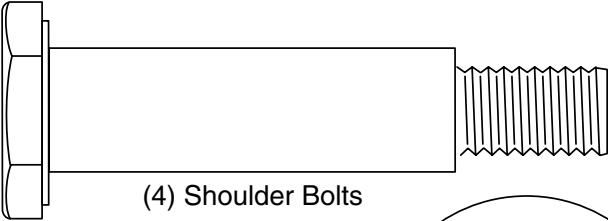
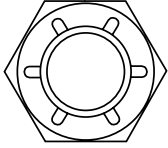
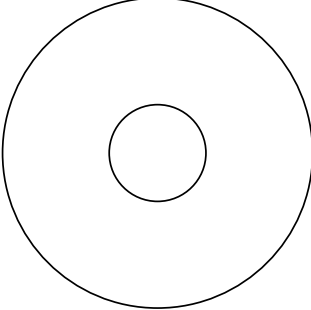
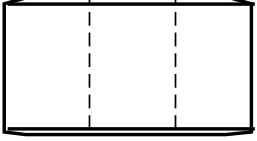
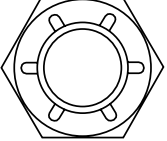

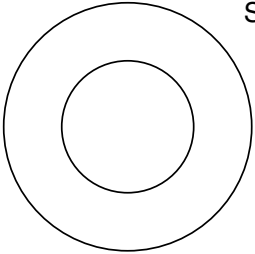
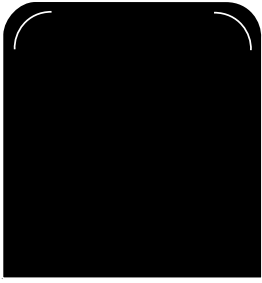
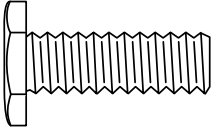
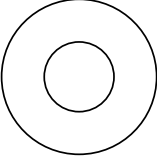
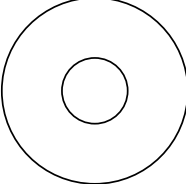
One (1) only of the Starter Rope Guides shown below:

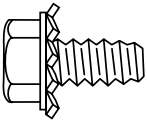

ASSEMBLY LOCATION	PARTS BAG CONTENTS	
<b>GROUP "A"</b>	<b>For models with Bolt-on lower handle only</b>	
<b>LOWER HANDLE TO MOWER DECK</b>	 (4) Hex Bolts 3/8-16 x 3/4	 (4) Washers 7/8" Dia.
	 (4) Flange Locknuts 3/8-16	
<b>GROUP "B"</b>	<b>For models with fixed upper handle only</b>	
<b>UPPER HANDLE TO LOWER HANDLE</b>	 (4) Hex Bolts 3/8-16 x 3/4	 (2) Locknuts 1/4-20
	 (1) Upstop Bracket Screw #10-24 x 1/2	
	<b>For models with folding upper handle only</b>	
	 (2) Handle Bolts	 (2) Wing Nuts

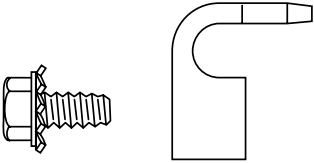
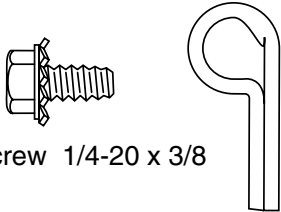
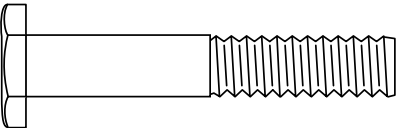
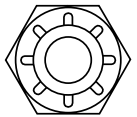
ASSEMBLY LOCATION	PARTS BAG CONTENTS (continued)	
<b>GROUP "C"</b>	<b>For models with bolt-on wheels only</b>	
<b>WHEELS TO MOWER HOUSING</b>	 <p>(4) Shoulder Bolts</p>	 <p>(4) Locknuts 3/8-16</p>  <p>(2 or 4) Washers 1-1/4" Dia.</p>
	 <p>(4) Spacers</p>	<b>For models with "Quick Adjust" wheel height adjusters only</b>
	 <p>(4) Flanged Locknuts 3/8-16</p>	
 <p>(4) Retainer Springs</p>  <p>(4) Washers 1" Dia.</p>  <p>(4) Wheel Adjuster Knobs</p>		
<b>GROUP "D"</b>	<b>For models with bolt-on discharge guard only</b>	
<b>GUARD TO MOWER HOUSING</b> (Side Discharge models only)	 <p>(2) Hex Bolts 1/4-20</p>	 <p>(2) Spacers (If equipped)</p>  <p>(2) Washers 3/4" Dia.</p>  <p>(2) Locknuts 1/4-20</p>
	<p>Screw Mounted</p>  <p>(2) Hex Washer Head Self-tapping Screws 1/4-20 x 3/8</p>	<p style="text-align: center;"><b>For models with spring loaded discharge guard only</b></p> <p style="text-align: right;">Nut Mounted</p> <p>(2) Locknuts 1/4-20</p> 

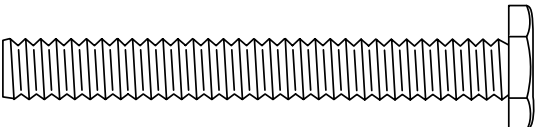
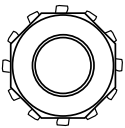
ASSEMBLY LOCATION	PARTS BAG CONTENTS CON'T	
<b>GROUP "E"</b>  <b>REMOTE THROTTLE CONTROL (If equipped) TO ENGINE</b>	  	<p>(1) Diecast Clamp with #10 x 5/8 Hex Head Screw (For Briggs Engines only)</p> <p><b>NOTE:</b> Tecumseh engines have clamp and screw preassembled to engine.</p> <p>(1) Cable Clip with #10 x 5/8 Hex Head Screw (For Briggs Classic &amp; Sprint Engines only with spark plug to front of mower)</p> <p>(2) Screw 1/4-20 x 3/8</p>
<b>GROUP "F"</b>  <b>CONTROL CABLE(S) TO UPPER HANDLE</b>	<p style="text-align: center;"><b>For models without remote throttle control</b></p> <div style="display: flex; justify-content: space-around;"> <div data-bbox="581 842 976 1037">  <p>(1) Hex Bolt 1/4-20 x 1-1/2</p> </div> <div data-bbox="1133 842 1268 1037">  <p>(1) Locknut 1/4-20</p> </div> </div> <p style="text-align: center;"><b>For models with remote throttle control</b></p> <div style="display: flex; justify-content: space-around;"> <div data-bbox="553 1136 683 1339">  <p>(1) Locknuts 1/4-20</p> </div> <div data-bbox="805 1125 1338 1346">  <p>(1) Hex Head Screw 1/4-20 x 2-1/8</p> </div> </div>	
<b>GROUP "G"</b>  <b>STARTER ROPE GUIDE TO HANDLE</b>	<div style="text-align: center;">  <p>(1) Keps Locknut 1/4-20</p> </div>	



# ASSEMBLY

**⚠CAUTION:** Do not operate this mower without the discharge guard or an entire approved grass catcher in place. These guards are for your protection and are required by the American National Standards Institute and Consumer Products Safety Commission.

**⚠CAUTION:** Disconnect spark plug wire from spark plug and place wire where it cannot come in contact with spark plug.

## ASSEMBLE LOWER HANDLE (USE HARDWARE GROUP "A")

### MODELS WITH BOLT-ON LOWER HANDLE

- For ease of lower handle assembly, raise rear of deck and block securely.
- Position lower handle on deck as shown:
  - (20" mowers) cut-off flat forward.
  - (22" mowers) arrow down.
- Align holes in handle with holes in deck as shown and assemble 3/8-16 x 3/4 hex bolts, 7/8" washers and flanged locknuts. Tighten securely.
- Repeat for opposite side of mower.

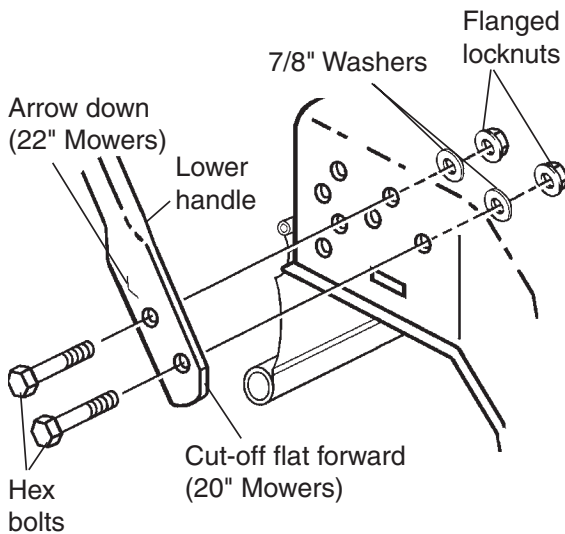

### MODELS WITH DECK HANDLE BRACKETS

- Install lower handle onto handle brackets by squeezing the bottom ends of handle towards each other until the handle will slip onto the mounting pins on the handle brackets.
- Pull handle back to lock in operating position.
- Install the two (2) hairpin cotters supplied onto the mounting pins.

(REAR DISCHARGE MOWER SHOWN)

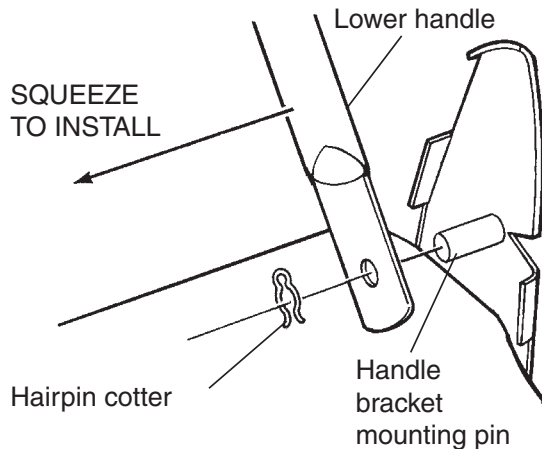

## ASSEMBLE UPPER HANDLE (USE HARDWARE GROUP "B")

### MODELS WITH FIXED (NON-FOLDING) HANDLES

- Position upper handle over lower handle:
  - (20" mowers) small hole for mounting upstop bracket to left hand side.
  - (22" mowers) side of handle with four (4) holes as shown to left hand side.
- Assemble 1/4-20 x 1-1/2 hex bolts and 1/4-20 locknuts. Tighten securely.

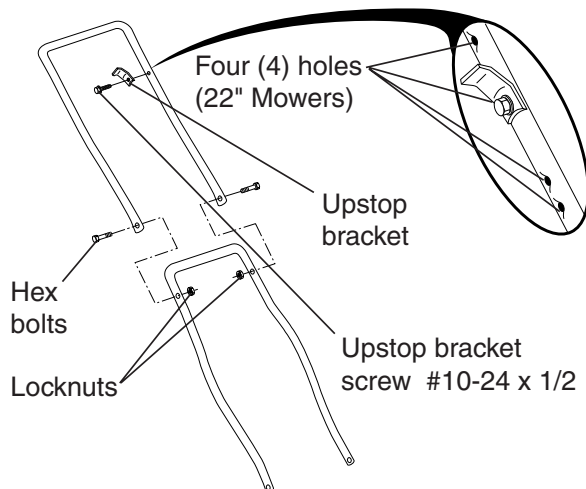

## MODELS WITH FOLDING UPPER HANDLE

- Position upper handle over lower handle with small hole for mounting upstop bracket to left hand side.
- Assemble handle bolts and wing nuts. Tighten securely.

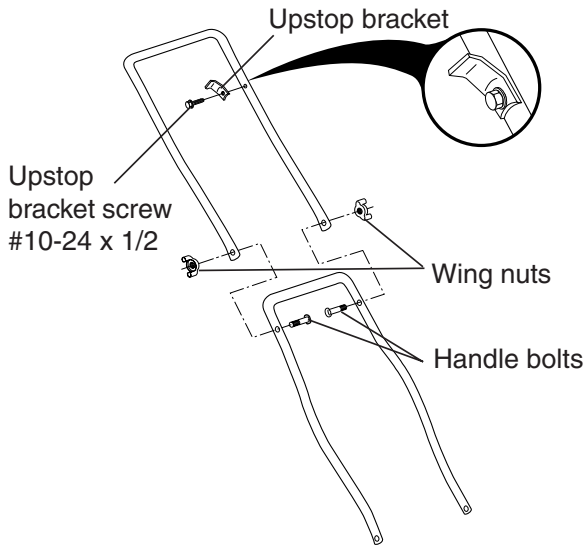

## ASSEMBLE UPSTOP BRACKET (SEE ILLUSTRATION ABOVE)

- Position upstop bracket over hole inside the left side of upper handle and install upstop bracket screw #10-24 x 1/2. Tighten securely.

## ASSEMBLE WHEELS (USE HARDWARE GROUP "C")

**NOTE:** Some model mowers do not have baffles on underside of mower housing. On models without baffle in front and/or rear of housing, use the 1-1/4" washers supplied when you assemble the wheels.

## MODELS WITH BOLT-ON WHEELS

Cutting height is determined by assembling wheels in one of four possible positions on the mower housing. All wheels must be in the same height position for even cutting.

- For each wheel, assemble shoulder bolt, wheel and spacer as shown.
- Assemble 1-1/4" diam. washer (if supplied) and 3/8-16 locknut on inside of mower housing and tighten securely.

## (SIDE DISCHARGE MOWER SHOWN)

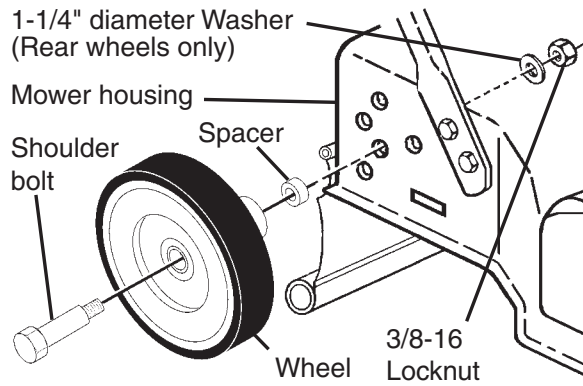

## MODELS WITH "QUICK ADJUST" WHEEL HEIGHT ADJUSTERS

Look carefully at the four (4) adjuster assemblies. Notice that there are two (2) each of two (2) different types.

**Type I** is for the Right Rear and Left Front installation.

**Type II** is for the Right Front and Left Rear installation.

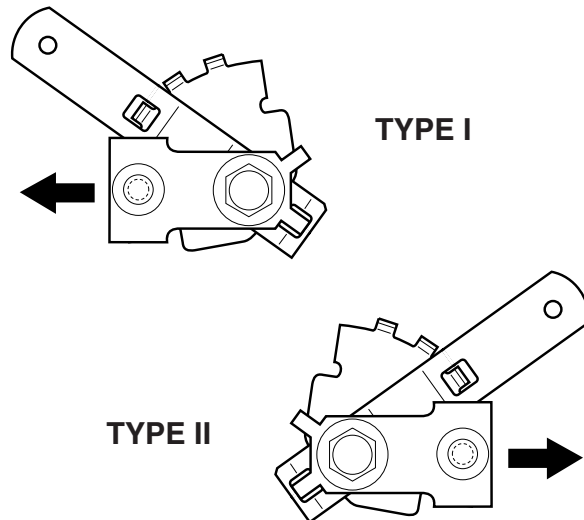

## ASSEMBLE ADJUSTERS TO MOWER DECK

- Position appropriate adjuster at each corner of mower.
- Install each adjuster with adjuster bolt and tab in deck holes as shown and secure with 1-1/4" diam. washer (if supplied) and 3/8-16 locknut. Tighten all adjusters securely.

## SIDE DISCHARGE MOWERS

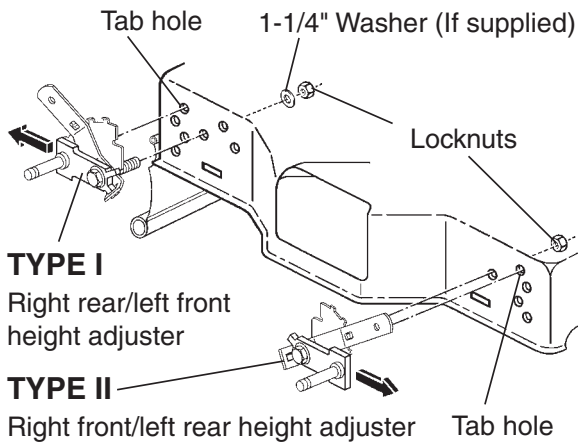

### TYPE I

Right rear/left front height adjuster

### TYPE II

Right front/left rear height adjuster

## REAR DISCHARGE MOWERS

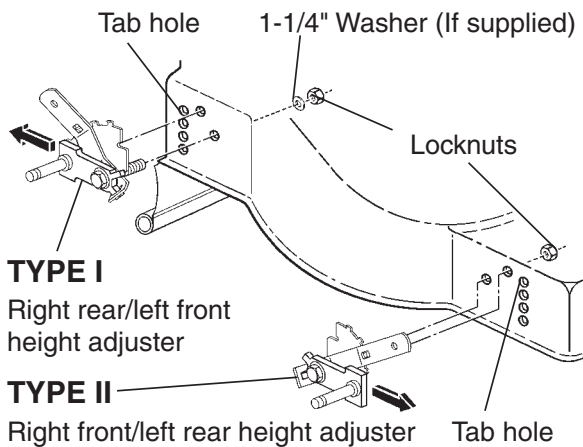

### TYPE I

Right rear/left front height adjuster

### TYPE II

Right front/left rear height adjuster

## ASSEMBLE WHEELS TO ADJUSTER AXLE ARMS

- Secure each wheel with flat washer and retainer spring or flange locknut (if equipped with threaded axle).
- Assemble adjustment knobs to adjuster levers by pressing or tapping lightly.
- If your mower is equipped with hubcaps, install by pressing or tapping lightly until hubcap snaps securely over flat washer.

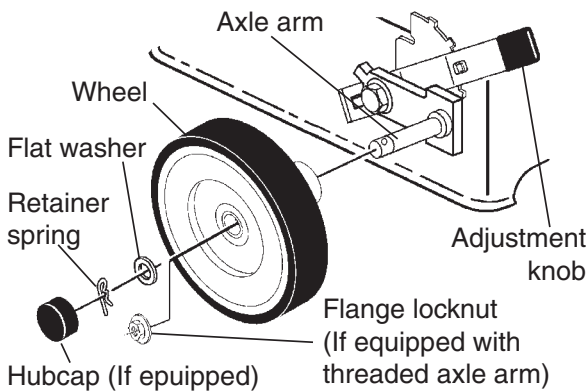

## INSTALL DISCHARGE GUARD (SIDE DISCHARGE MODELS ONLY) (USE HARDWARE GROUP "D")

If your mower is a rear discharge mower, go on to "INSTALL CONTROL BAR".

### MODELS WITH BOLT-ON GUARD

**NOTE:** If your discharge guard has ribbing as shown in the illustration below, there are two (2) spacers which must be placed between guard and mower housing.

- Place discharge guard on top of lawn mower discharge opening.
- Install two (2) 1/4-20 short hex bolts through housing and discharge guard.
- Install two (2) 3/4" washers and two (2) 1/4-20 locknuts. Tighten securely.

### BOLT-ON GUARD WITH RIBBING

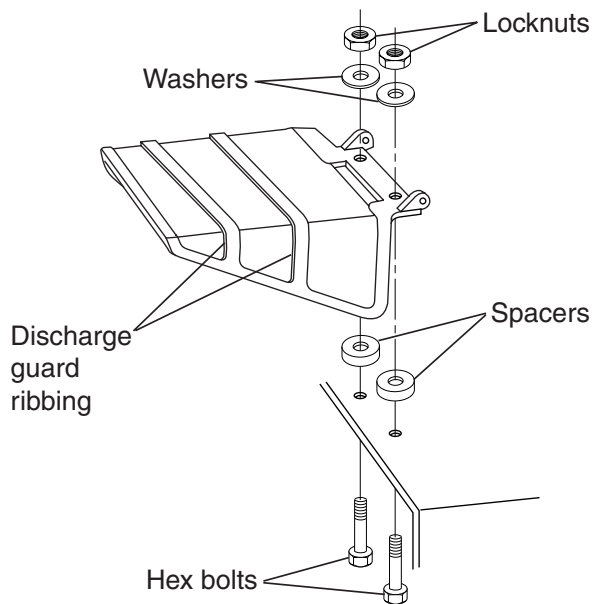

### BOLT-ON GUARD WITHOUT RIBBING

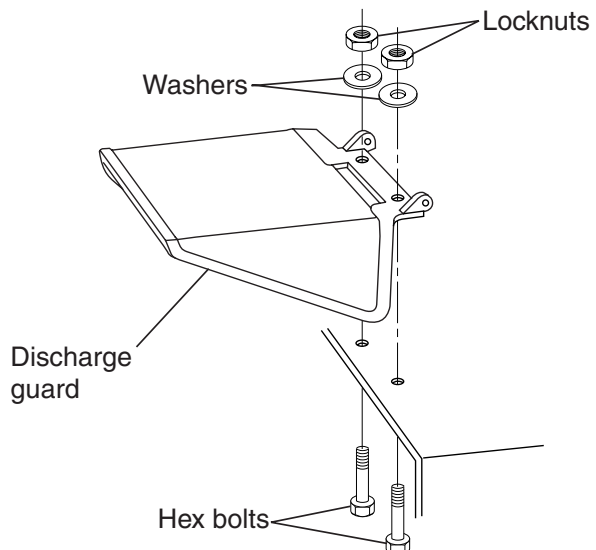

## MODELS WITH SPRING LOADED DISCHARGE GUARD

- Place discharge guard on top of lawn mower discharge opening.
- Install two (2) hex self-tapping screws through housing and into guard mounting bracket or, install two (2) 1/4-20 locknuts (if equipped). Tighten securely.

### SCREW MOUNTED TYPE

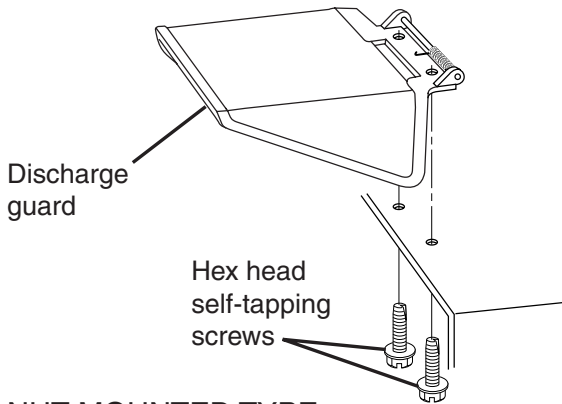

### NUT MOUNTED TYPE

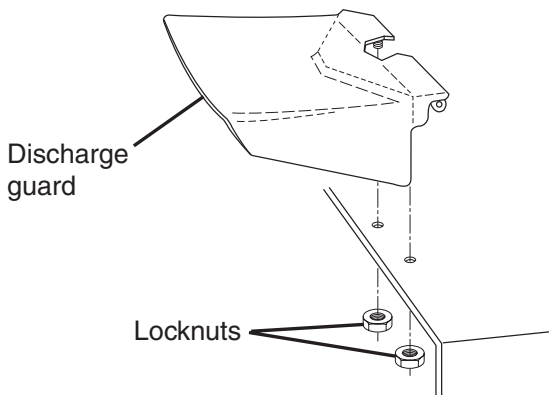

## INSTALL CONTROL BAR (NO HARDWARE REQUIRED)

- Position control bar so flattened section with hole is on opposite side of upstop bracket.
- Insert one end of control bar into hole behind upstop bracket. Carefully push in on opposite end of control bar and insert into formed hole on inside of upper handle.

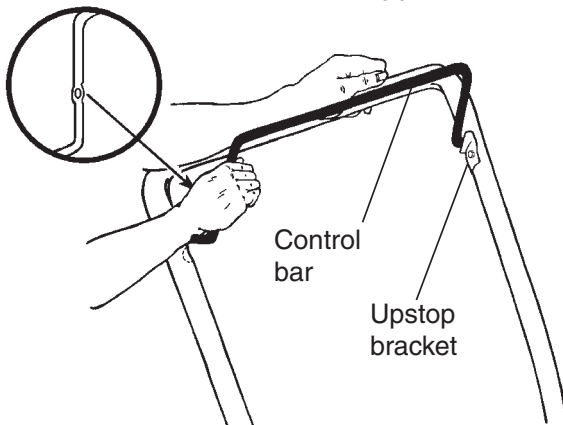

## ASSEMBLE REMOTE THROTTLE CONTROL TO ENGINE (ON MODELS SO EQUIPPED) (USE HARDWARE GROUP "E")

If your mower does not have a remote throttle control, go on to "ASSEMBLE ENGINE ZONE CONTROL CABLE TO ENGINE".

- First, move lever on remote throttle control to the CHOKE (if equipped) or FAST/START position.

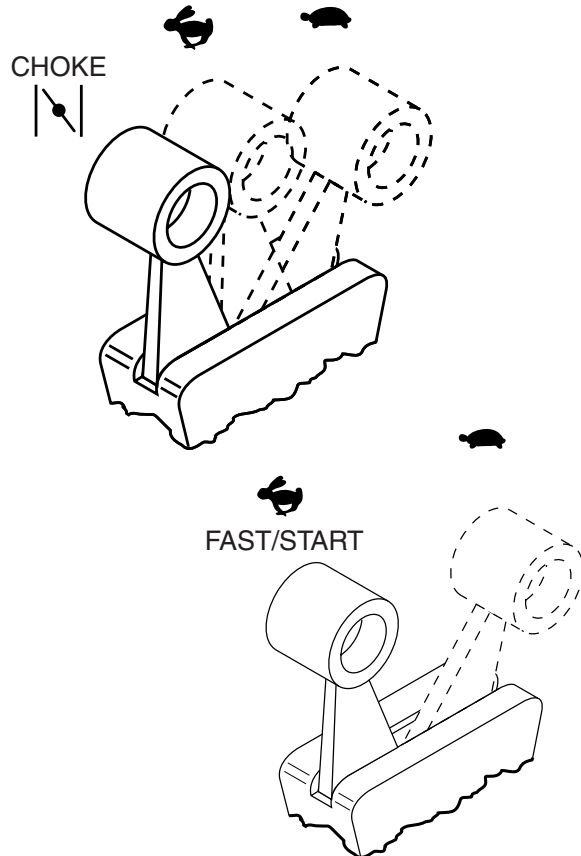

Determine the manufacturer and brand or type engine on your lawn mower and follow the appropriate instructions that follow.

## MODELS WITH BRIGGS & STRATTON CLASSIC OR SPRINT AND TECUMSEH ENGINES

**NOTE:** Tecumseh engines have cable mounting clamp and screw preassembled on engine.

- At engine carburetor, insert wire "Z" bend of throttle control into hole of speed lever (use inner hole on Briggs & Stratton engine).
- (Briggs & Stratton only) Assemble die-cast clamp and #10 x 5/8 screw loosely to engine.
- Position throttle cable under clamp and push cable towards speed lever until speed lever touches boss. Hold cable at this position and tighten clamp screw securely.

**BRIGGS & STRATTON ENGINE SHOWN**  
(Clamp and Screw are preassembled on  
Tecumseh engines)

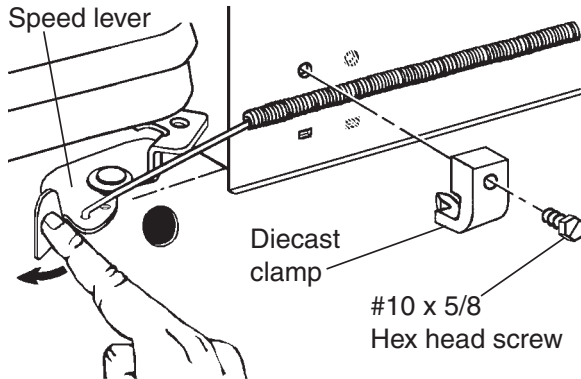

**BRIGGS & STRATTON CLASSIC AND  
SPRINT ENGINES WITH THE SPARK  
PLUG TO FRONT OF MOWER**

- Attach throttle cable to side of engine housing with cable clip and #10 x 5/8 hex washer head screw. Tighten securely.

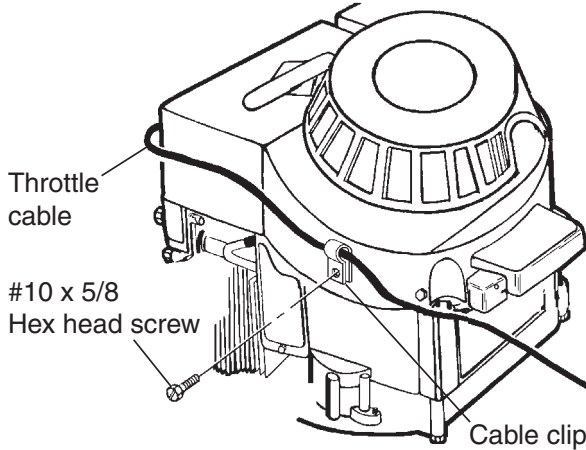

**MODELS WITH BRIGGS &  
STRATTON QUANTUM ENGINES**

- Slide throttle lever on engine to **CHOKE** position (away from spark plug). Push gently beyond first stop to lock in detent (**CHOKE** position).
- Insert wire "Z" bend of throttle cable into throttle lever hole from top side.
- Secure throttle cable to engine with diecast clamp and #10 x 5/8 hex head screw and tighten securely.

**QUANTUM ENGINES -  
SPARK PLUG TO FRONT OF MOWER**

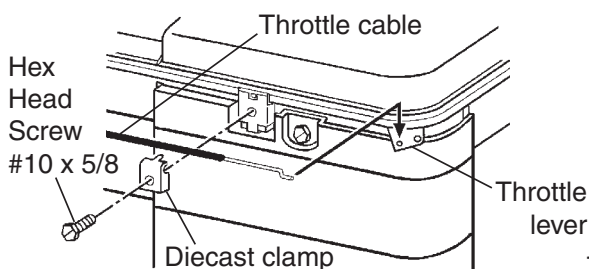

**QUANTUM ENGINES -  
SPARK PLUG TO REAR OF MOWER**

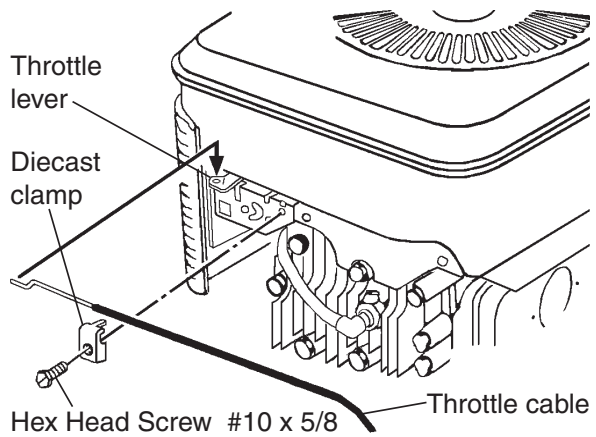

**ASSEMBLE ENGINE ZONE  
CONTROL CABLE TO ENGINE  
(NO HARDWARE REQUIRED)**

Follow the appropriate instructions below for the brand or type of engine on your lawn mower.

**MODELS WITH BRIGGS & STRATTON  
CLASSIC OR SPRINT ENGINE**

Cable attaches under the brake arm cover, which is opposite the spark plug end of engine.

- Straighten cable and find the end with the small plastic fitting.
- Hook the "Z" bend fitting on inner wire of cable into hole in brake arm of engine.
- Align the tapered end of the plastic fitting with the hole in mounting bracket and push in until fitting snaps into place.
- Route cable below crossbar portion of lower handle and up to upper handle control bar.
- Hook "Z" bend fitting on inner wire into hole in control bar (See "ASSEMBLE CABLES TO UPPER HANDLE" in this manual).

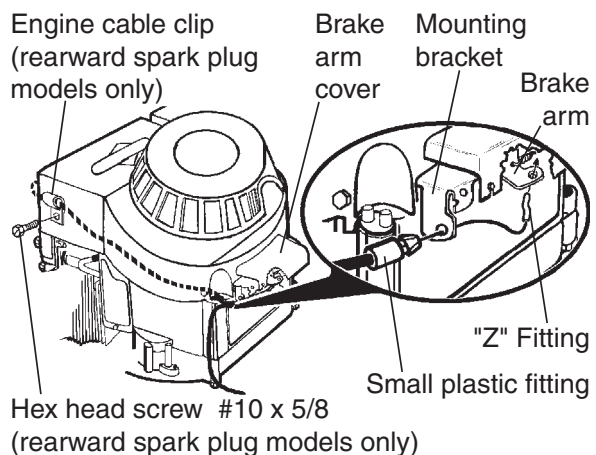

## MODELS WITH SPARK PLUG TO REAR OF MOWER

To prevent cable damage, the cable must be attached to the side of engine, away from the muffler.

- Above the muffler, locate the hole in engine shroud. Install supplied cable clip on cable and assemble to side of engine with supplied hex head screw. Tighten securely.

## MODELS WITH TECUMSEH ENGINE

- Straighten cable and find the end with the small tapered plastic fitting.
- Hook the “Z” bend fitting on inner wire of cable into hole as shown.
- Align the tapered end of the plastic fitting with the hole in the mounting bracket and push in until fitting snaps into place.
- Route cable under crossbar portion of lower handle and up to upper handle control bar.
- Hook “Z” bend fitting on inner wire into hole in control bar (See “ASSEMBLE CABLES TO UPPER HANDLE” in this manual).

## TECUMSEH ENGINES WITH SPARK PLUG FORWARD

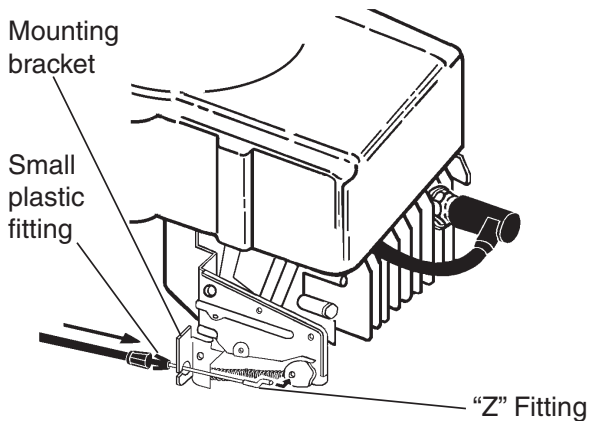

## TECUMSEH ENGINES WITH SPARK PLUG REARWARD

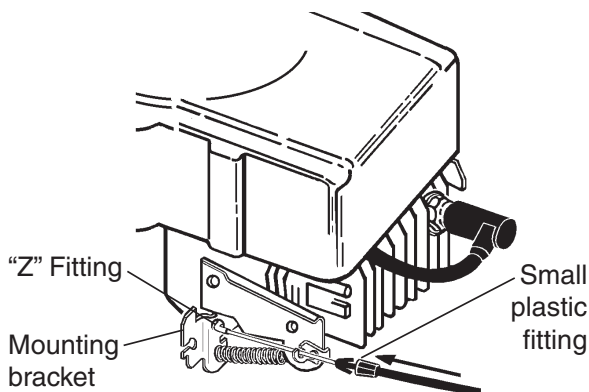

## MODELS WITH BRIGGS & STRATTON QUANTUM ENGINES

- Hook the “Z” bend fitting on inner wire of cable (end with tapered plastic fitting) into hole in brake lever of engine. Correct brake lever to use is determined by position of spark plug on your mower - forward or rearward.
- Position the tapered plastic fitting into the mounting bracket on engine. Snap fitting into place.
- Route cable under crossbar portion of lower handle and up to upper handle control bar.
- Hook “Z” bend fitting on inner wire into hole in control bar (See “ASSEMBLE CABLES TO UPPER HANDLE”).

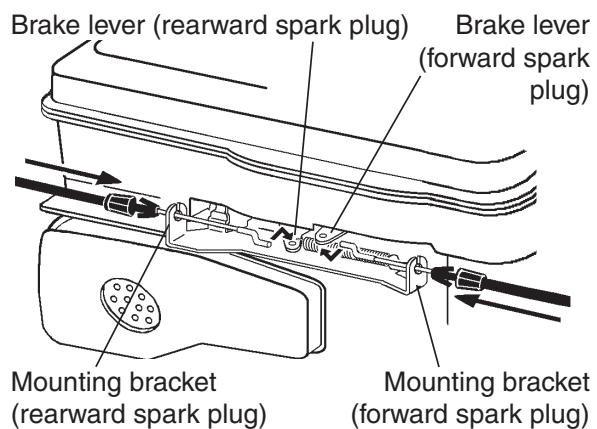

## ASSEMBLE CABLE(S) TO UPPER HANDLE (USE HARDWARE GROUP “F”)

- Assemble cable(s) to opposite side of upstop bracket.
- Be sure to route cable(s) underneath crossbar of lower handle.
- Position throttle control (if equipped) on outside of handle and zone control square fitting on the inside.
- Secure to handle with the 1/4-20 machine screw or hex bolt supplied and locknut as shown. Tighten securely.
- Secure cable(s) to crossbar and lower handle with cable ties as needed.

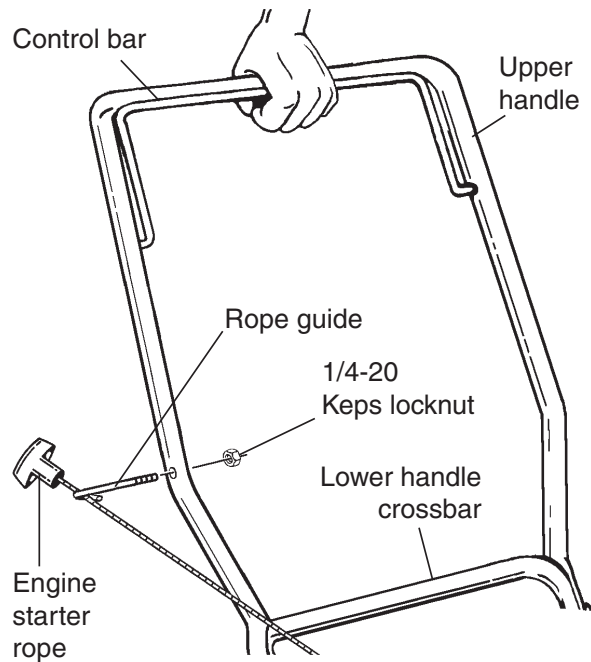
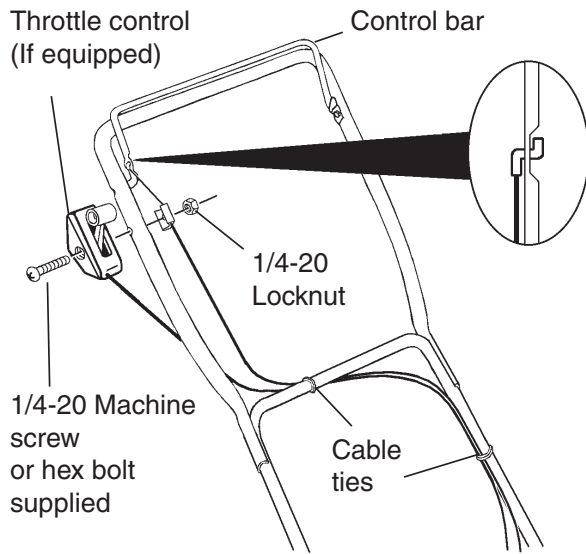

## ASSEMBLE STARTER ROPE GUIDE (USE HARDWARE GROUP "G")

### CENTER MOUNT TYPE

- Install threaded end of rope guide through hole in top of lower handle crossbar.
- Loosely assemble 1/4-20 keps locknut on threaded portion of rope guide. Do not tighten.
- Hold control bar against upper handle and slowly pull starter rope out and up over lower handle crossbar and slip into loop of rope guide.
- Push rope guide down against crossbar and tighten nut securely.

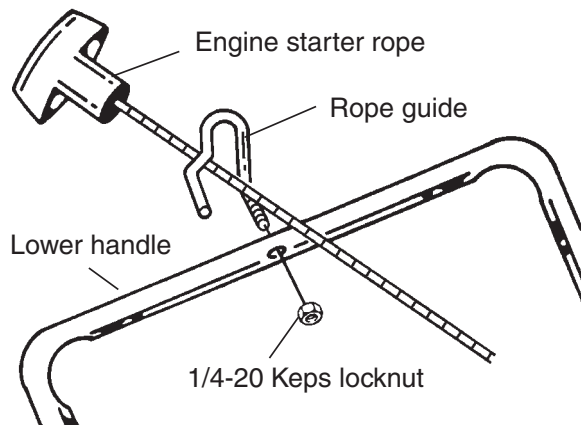

### SIDE MOUNT TYPE

- Put threaded end of rope guide through hole in side of upper handle above lower handle crossbar. Secure with 1/4-20 keps locknut.
- Hold control bar against upper handle and slowly pull starter rope out until rope will slip into loop of rope guide.

## SPARK PLUG BOOT (IF EQUIPPED) (NO HARDWARE REQUIRED)

On some model lawn mowers a spark plug boot is packed loose in the parts bag. If your model has one, install it on spark plug wire and then reconnect plug to spark plug.

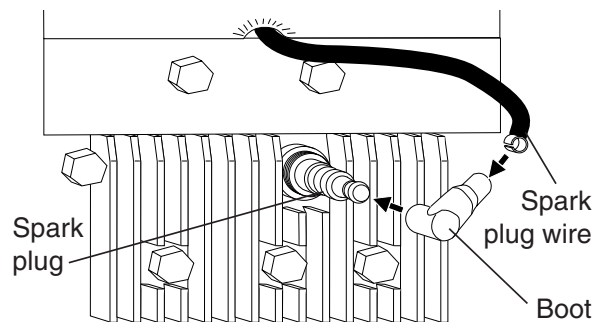

## ASSEMBLE GRASS CATCHER (REAR DISCHARGE MODELS ONLY) (NO HARDWARE REQUIRED)

- Put grass catcher frame into grass bag with rigid part on bottom.
- Slip vinyl bindings over frame. If bindings are too stiff, hold them in warm water for a few minutes. Allow bag to dry before using.

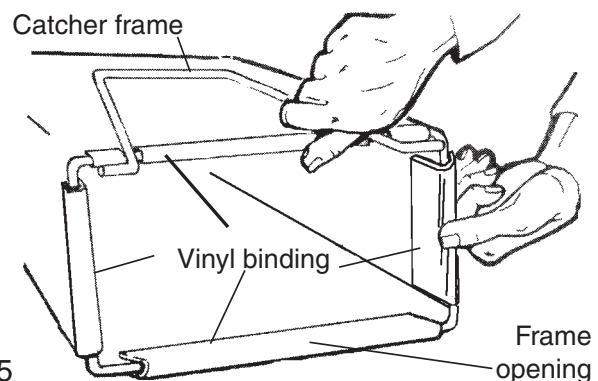

# OPERATION



The operation of any lawn mower can result in foreign objects thrown into the eyes, which can result in severe eye damage. Always

wear safety glasses or eye shields while operating your lawn mower or performing any adjustments or repairs. We recommend standard safety glasses or a wide vision safety mask worn over spectacles.

## HOW TO USE YOUR LAWN MOWER ENGINE SPEED CONTROL

### MODELS WITH REMOTE THROTTLE

Engine speed is controlled by the throttle control located on the upper handle.

- Move lever forward to FAST engine speed for starting and better bagging.
- Move lever backward for SLOW engine speed.
- Some models have engines equipped with a choke feature. Move the lever all the way forward to the CHOKE position when starting a cold engine.

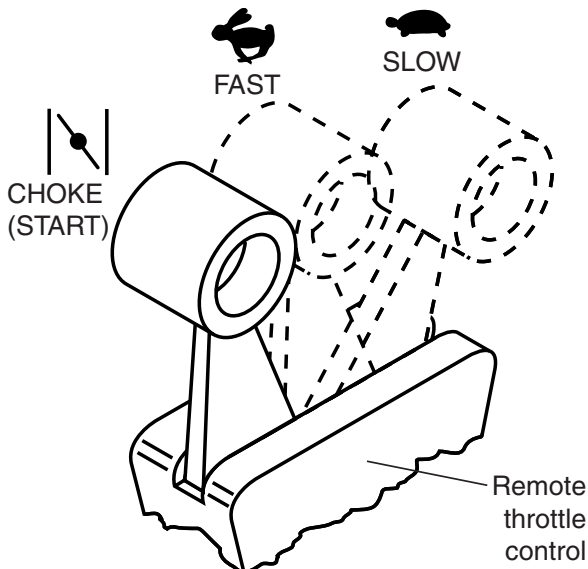

### MODELS WITH ENGINE MOUNTED SPEED CONTROL

The engine speed is controlled by a lever located at the carburetor on the engine. HIGH or FAST position is for starting engine, normal cutting and better grass bagging. LOW or SLOW position is for light cutting, trimming and fuel economy.

### MODELS WITH FIXED SPEED ENGINES

Engine speed was set at the factory for optimum performance. Engine speed is not adjustable.

### BRIGGS & STRATTON CLASSIC or SPRINT ENGINE MOUNTED SPEED CONTROL

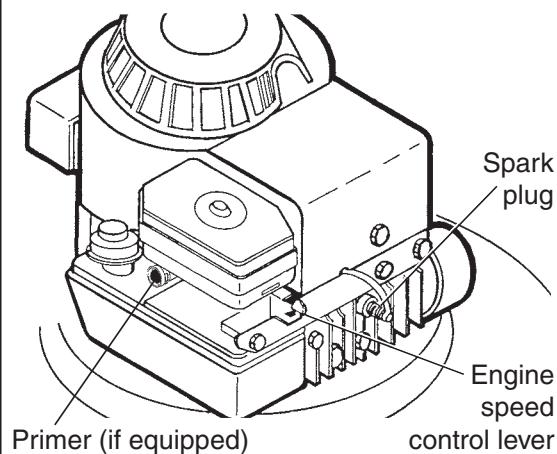

### BRIGGS & STRATTON QUANTUM ENGINE MOUNTED SPEED CONTROL

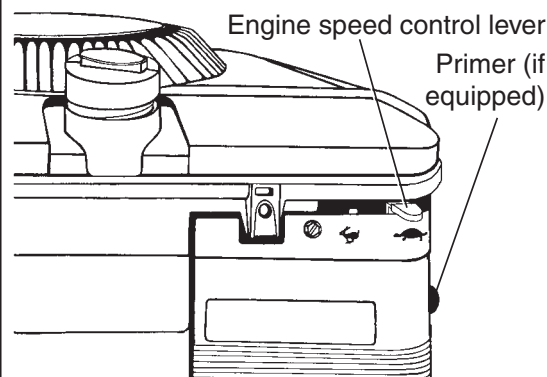

### TECUMSEH ENGINE MOUNTED SPEED CONTROL

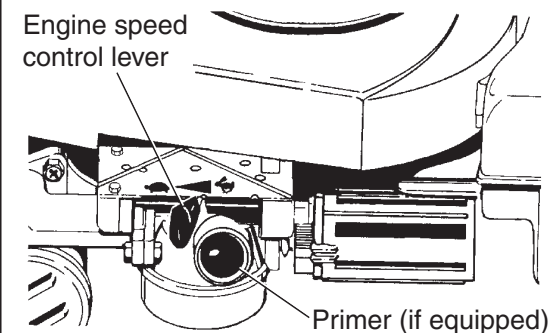



## TO ADJUST CUTTING HEIGHT

Adjust cutting height to suit your requirements. Medium position is best for most lawns. Raise wheels for low cut and lower wheels for high cut.

### MODELS WITH MANUAL ADJUST BOLT-ON WHEELS

- Remove wheel, bolt, and hardware and reassemble in desired adjustment hole.
- Reinstall wheel components in the same order as they were before removal. Tighten securely.
- Make sure all wheels are at the same height.

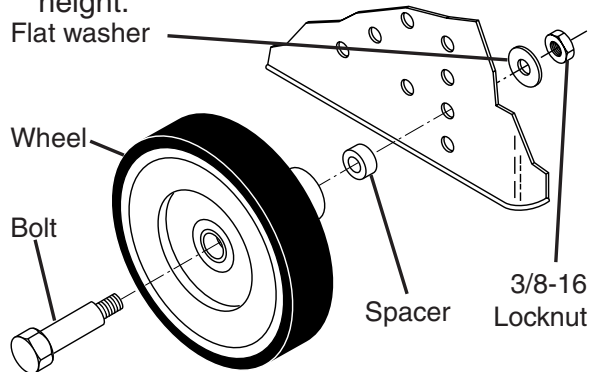

### MODELS WITH "QUICK ADJUST" WHEEL HEIGHT ADJUSTERS

**NOTE:** For shipping purposes, the rear wheels on your lawn mower may not be adjusted to the same position as the front wheels. Before operating mower, adjust all wheels to the same cutting height.

- Raise wheels for low cut and lower wheels for high cut.
- Adjust cutting height to suit your requirements. Medium position is best for most lawns.
- To change cutting height, squeeze adjuster lever toward wheel. Move wheel up or down to suit your requirements. Be sure all wheels are in the same setting.

**NOTE:** Adjuster is properly positioned when plate tab inserts into hole in lever. Also, 9-position adjusters (if so equipped) allow lever to be positioned between the plate tabs.

#### LOWER WHEELS FOR HIGH CUT

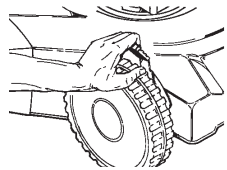

#### RAISE WHEELS FOR LOW CUT

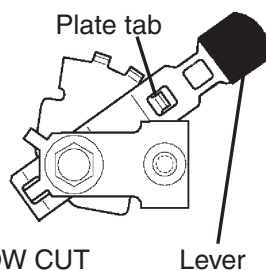

## OPERATOR PRESENCE ENGINE CONTROL BAR

Your lawn mower is equipped with an operator presence engine control bar which requires the operator to be positioned behind the lawn mower handle in order to start and operate the lawn mower.

**CAUTION:** Federal regulations require an engine control to be installed on this lawn mower in order to minimize the risk of blade contact injury. Do not under any circumstances attempt to defeat the function of the operator control. The blade turns when the engine is running.

## GRASS CATCHER (REAR DISCHARGE MODELS ONLY)

### TO ATTACH GRASS CATCHER

- Open rear door. Place frame onto formed tabs on hinge bracket.
- Release rear door and allow to rest on catcher.

### TO REMOVE GRASS CATCHER

- Simply open rear door and lift grass catcher up and away from mower.

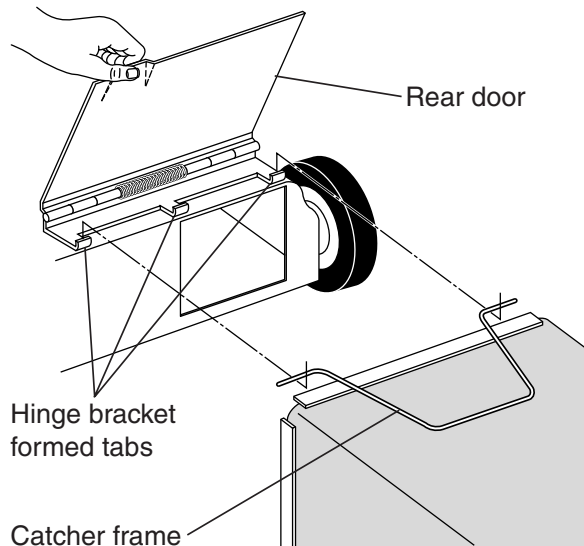

**CAUTION:** Under normal usage, the catcher material is subject to deterioration and wear and should, therefore, be checked frequently for replacement. Any replacement catcher should be checked to ensure compliance with original manufacturer's specifications.

**CAUTION:** Do not run lawn mower without the discharge guard (rear door), approved grass catcher or clipping deflector in place. Never attempt to operate mower with the discharge guard (rear door) removed or propped open.

## BEFORE STARTING ENGINE

Read engine manual packed with your unit.

### FILL ENGINE WITH OIL

Your lawn mower is shipped without oil in the engine.

- Be sure mower is level and area around oil fill is clean.
- Remove engine oil filler plug (oil fill cap/dipstick on models so equipped).
- Slowly add oil. For type and grade of oil to use, see "ENGINE" in the Maintenance section of this manual.
- Fill to the top of slot in filler hole (to "FULL" line on dipstick on models so equipped). Do not overfill.
- Replace plug (oil fill cap/dipstick on models so equipped) and tighten.
- Check oil level before each use. Add oil as needed.
- To change oil, see "TO CHANGE ENGINE OIL" in the Maintenance section of this manual.

### FILL GASOLINE TANK

- Fill gasoline tank with fresh, clean, unleaded gasoline. **DO NOT USE PREMIUM GASOLINE.** BE CAREFUL NOT TO OVERFILL TANK.

**WARNING:** Experience indicates that alcohol blended fuels (called gasohol or using ethanol or methanol) can attract moisture which leads to separation and formation of acids during storage. Acidic gas can damage the fuel system of an engine while in storage. To avoid engine problems, the fuel system should be emptied before storage of 30 days or longer. Drain the fuel tank, start the engine and let it run until fuel lines and carburetor are empty. Use fresh fuel next season. See Storage Instructions for additional information. Never use engine or carburetor cleaner products in fuel tank or permanent damage may occur.

### TO START ENGINE

**CAUTION:** The mower blade rotates whenever the engine is running.

- Move engine speed control to FAST position or to CHOKE/START position on models equipped with choke feature.
- If your mower has a primer, to start a cold engine, push primer the number of times as instructed in the engine manual packed with your mower. Use a firm push. This step is not usually necessary when starting an engine which has already run for a few minutes.

- Hold operator presence control bar down against handle.
- Pull starter handle quickly. Do not allow starter rope to snap back.
- For engines equipped with choke, slowly move engine speed control lever to FAST position after engine starts.
- To STOP engine, release operator presence engine control bar.

**NOTE:** For engines with a primer, it may be necessary to repeat priming steps in cooler weather. In warmer weather, overpriming may cause flooding and engine will not start. If you do flood engine, wait a few minutes before attempting to start and **DO NOT** repeat priming steps.

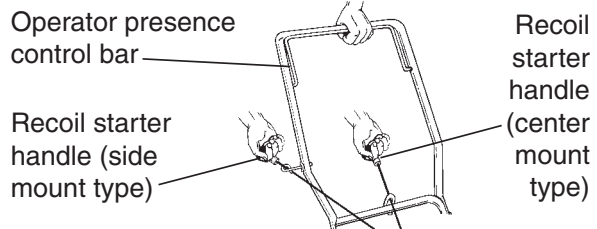

### MOWING TIPS

- For most cutting conditions and better bagging performance, the engine speed should be set in the FAST position.
- Under certain conditions, such as when mowing very tall grass, raise the mower height on the first cut to reduce pushing effort, to avoid overheating the engine, and to avoid leaving clumps of grass clippings. Make the second cut to the desired height.
- For extremely heavy cutting, reduce the width of cut.
- For side discharge lawn mowers, cut in a counterclockwise direction, starting at the outside of the area to be cut, in order to spread grass clippings more evenly and to put less load on the engine. To keep clippings off of walkways, flower beds, etc., make the first cuts in a clockwise direction.
- When using a rear discharge lawn mower in moist, heavy grass, clumps of cut grass may not enter the grass catcher. Reduce ground speed (pushing speed) and/or run the lawn mower over the area a second time.
- If a trail of grass clipping is left on the right side of a rear discharge lawn mower, mow in a clockwise direction with a small overlap to collect the clippings on the next pass.
- Pores in cloth grass catchers can become filled with dirt and dust with use and the catcher will collect less grass. To prevent this, regularly hose catcher off with water and let dry before use.

# MAINTENANCE

<b>MAINTENANCE SCHEDULE</b>		BEFORE EACH USE	AFTER EACH USE	EVERY 10 HOURS	EVERY 25 HOURS OR EVERY SEASON	EVERY 100 HOURS	BEFORE STORAGE	SERVICE DATES								
<b>M O W E R</b>	Lubrication				✓											
	Check Tires	✓														
	Check Drive Wheels (Power-Propelled Mowers)	✓														
	Check for Loose Fasteners	✓									✓					
	Clean/Inspect Grass Catcher (If Equipped)	✓	✓								✓	✓				
	Clean Lawn Mower		✓								✓					
	Clean Under Drive Cover (Power-Propelled Mowers)			✓												
	Check drive belt/pulleys (Power-Propelled Mowers)					✓										
	Check/Sharpen/Replace Blade					✓ <sub>3</sub>					✓					
	Clean Battery/Recharge (Electric Start Mowers)					✓					✓ <sub>4</sub>					
<b>E N G I N E</b>	Check Engine Oil Level	✓ <sub>5</sub>														
	Change Engine Oil				✓ <sub>1,2</sub>											
	Clean Air Filter				✓ <sub>2</sub>											
	Inspect Muffler				✓											
	Replace Spark Plug									✓						
Replace Air Filter Paper Cartridge									✓ <sub>2</sub>							

- 1 - Change more often when operating under a heavy load or in high ambient temperatures.  
 2 - Service more often when operating in dirty or dusty conditions.  
 3 - Replace blades more often when mowing in sandy soil.  
 4 - Charge 48 hours at end of season.  
 5 - And after each 5 hours of use.

## GENERAL RECOMMENDATIONS

The warranty on this lawn mower does not cover items that have been subjected to operator abuse or negligence. To receive full value from the warranty, operator must maintain mower as instructed in this manual. Some adjustments will need to be made periodically to properly maintain your unit. All adjustments in the Service and Adjustments section of this manual should be checked at least once each season.

- Once a year, replace the spark plug, clean or replace air filter element, and check blade for wear. A new spark plug and clean/new air filter element assures proper air-fuel mixture and helps your engine run better and last longer.
- Follow the Maintenance Schedule in this manual.

### BEFORE EACH USE

- Check engine oil level.
- Check for loose fasteners.

### LUBRICATION

Keep unit well lubricated.

**IMPORTANT:** Do not oil or grease plastic wheel bearings. Viscous lubricants will attract dust and dirt that will shorten the life

## LUBRICATION CHART

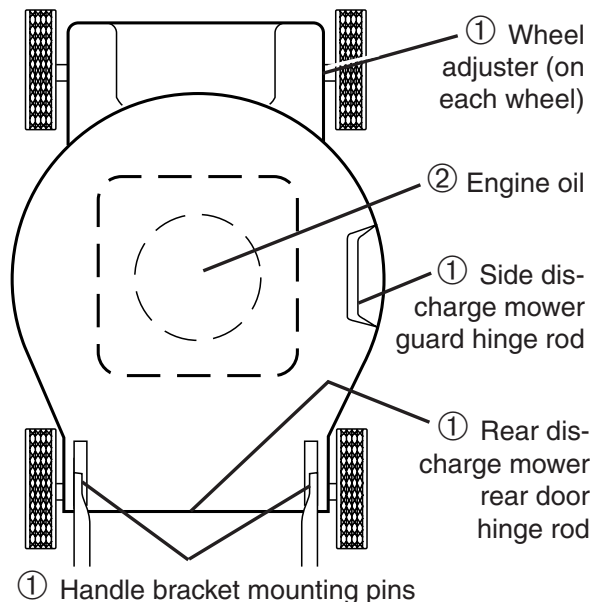

- ① **Spray lubricant**
- ② **See "ENGINE" in Maintenance section.**

of the self-lubricating bearings. If you feel they must be lubricated, use only a dry, powdered graphite type lubricant sparingly.

## LAWN MOWER

Always observe safety rules when performing any maintenance.

### TIRES

- Keep tires free of gasoline, oil, or insect control chemicals which can harm rubber.
- Avoid stumps, stones, deep ruts, sharp objects and other hazards that may cause tire damage.

### BLADE CARE

For best results, mower blade must be kept sharp. Replace bent or damaged blades.

### TO REPLACE BLADE

- Turn lawn mower on it's side. See engine manual for proper direction of turning over the engine.
- Use a wood block between blade and mower housing to prevent blade from turning when removing blade bolt.
- Protect your hands with gloves and/or wrap blade with heavy cloth.
- Remove blade bolt, lock washer and flat washer.
- Remove blade and blade adapter.
- Inspect the key inside blade adapter. Replace adapter if damaged.

**IMPORTANT:** Blade bolt is grade 8 heat treated.

- Install new or sharpened blade with trailing edge up toward the engine.
- Position blade on blade adapter. Align the two (2) holes in blade with raised lugs of adapter.
- Reassemble blade bolt, lock washer and flat washer into blade adapter and crankshaft in exact order as shown.
- Position block of wood between blade and mower housing.
- Tighten blade bolt securely. Recommended tightening torque is 35-40 ft. lbs.

**NOTE:** We do not recommend sharpening the blade - but if you do, be sure the blade is balanced.

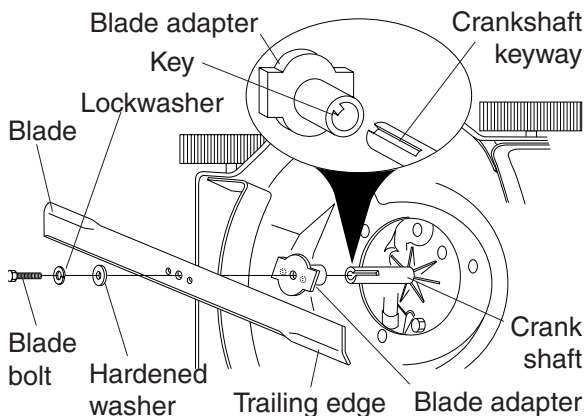

### TO SHARPEN BLADE

Care should be taken to keep the blade balanced. An unbalanced blade will cause excessive vibration and eventual damage to lawn mower and engine.

- The blade can be sharpened with a file or on a grinding wheel. Do not attempt to sharpen while on the mower.
- To check blade balance, drive a nail into a beam or wall. Leave about one inch of the straight nail exposed. Place center hole of blade over the head of the nail. If blade is balanced, it should remain in a horizontal position. If either end of the blade moves downward, sharpen the heavy end until the blade is balanced.

### GRASS CATCHER (IF SO EQUIPPED)

Grass catcher may be hosed with water but must be dry when used.

**CAUTION:** Under normal usage, the catcher material is subject to deterioration and wear and should therefore be checked to ensure compliance with original manufacturer specifications.

### ENGINE

Read the maintenance section of your engine manual.

### LUBRICATION

Change the oil after the first two hours of operation and every 25 hours thereafter or at least once a year if the lawn mower is not used for 25 hours in one year. Refer to engine manual.

### TO CHANGE ENGINE OIL (SEE ENGINE MANUAL)

- Be sure mower is on a level surface.
- Oil will drain more freely when warm.
- Catch oil in a suitable container.
- For engines without dipstick, remove bottom oil drain plug.
- For engines with oil fill cap/dipstick, remove bottom drain plug or remove engine oil cap and turn mower on its side.
- After oil has drained completely, replace oil drain plug and tighten securely.
- Refill engine with oil. Pour slowly. Do not overfill.
- Fill to top of slot inside of filler hole or to "FULL" line on dipstick on models so equipped. Keep oil at proper level.

## AIR FILTER

Your engine will not run properly and may be damaged by using a dirty air filter. Clean the element after every 25 hours of operation, more often if lawn mower is used in very dusty, dirty conditions. See the maintenance section of your engine manual.

## SPARK PLUG

Change the spark plug once a year to make the engine run better and easier to start. Set spark plug gap according to engine manual specifications.

## MUFFLER

Inspect and replace corroded muffler as it could create a fire hazard and/or damage.

## CLEANING

**IMPORTANT:** For best performance, keep mower housing free of grass build-up and trash. Clean the underside of your mower after each use.

- Clean the underside of your lawn mower by scraping to remove buildup of grass and trash.
- Clean engine often to keep trash from accumulating. A clogged engine runs hotter and shortens engine life.
- Keep finished surfaces and wheels free of all gasoline, oil, etc.

We do not recommend using a garden hose to clean your lawn mower unless the electrical system, muffler, air filter, and carburetor are covered to keep water out. Water in engine can shorten engine life.

# SERVICE AND ADJUSTMENTS

**⚠CAUTION:** Before performing any service or adjustments-

- Release operator presence control bar.
- Make sure the blade and all moving parts have completely stopped.
- Disconnect spark plug wire from spark plug and place wire where it cannot come in contact with spark plug.

## LAWN MOWER

### REAR DEFLECTOR (IF EQUIPPED)

The rear deflector, attached between the rear wheels of your mower, is provided to minimize the possibility that objects will be thrown out of the rear of the mower into the operator mowing position. If the deflector becomes damaged, it should be replaced.

## ENGINE

### CARBURETOR

The carburetor has been preset at the factory and adjustment should not be necessary. However, minor adjustment may be required to compensate for differences in fuel, temperature, altitude or load.

- The air filter must be assembled to the carburetor when running engine.
- Best carburetor adjustment is obtained when fuel tank is 1/4 full.
- In order for the engine to run, the operator presence control bar must be held in the operating position. Therefore, an assistant will be required to hold the control bar in the operating position when making final adjustment to the carburetor.

See the adjustment section of your engine manual for further instructions.

### ENGINE SPEED

The engine speed has been factory set. Do not attempt to increase engine speed as it may result in personal injury. If you believe the engine is running too fast or too slow, take your lawn mower to an authorized engine service center for repair and adjustment.

### THROTTLE CONTROL

If it becomes necessary to adjust or replace the throttle control, see the adjustment section of your engine manual.

## STORAGE

Immediately prepare your lawn mower for storage at the end of the season or if the unit will not be used for 30 days or more.

**CAUTION:** Never store the lawn mower with gasoline in the tank inside a building where fumes may reach an open flame or spark. Allow the engine to cool before storing in any enclosure.

### LAWN MOWER

When lawn mower is to be stored for a period of time, clean it thoroughly, remove all dirt, grease, leaves, etc. Store in a clean, dry area.

- Clean entire lawn mower (See “CLEANING” in the Maintenance section of this manual).
- Lubricate as shown in the Maintenance section of this manual.
- Be sure that all nuts, bolts, screws, and pins are securely fastened. Inspect moving parts for damage, breakage and wear. Replace if necessary.
- Touch up all rusted or chipped paint surfaces; sand lightly before painting.

### HANDLE STORAGE (HANDLE BRACKET MODELS ONLY)

Your handle may be folded for storage as shown.

- Squeeze the bottom ends of lower handle towards each other until handle clears the handle brackets and swing handles forward over mower.
- Loosen upper handle mounting hardware enough to allow upper handle to be folded back.

**IMPORTANT:** When folding handles for storage or transportation, be sure to fold handles as shown or you may damage the control cables.

When setting you handles up from the storage position, the lower handle will automatically lock into mowing position.

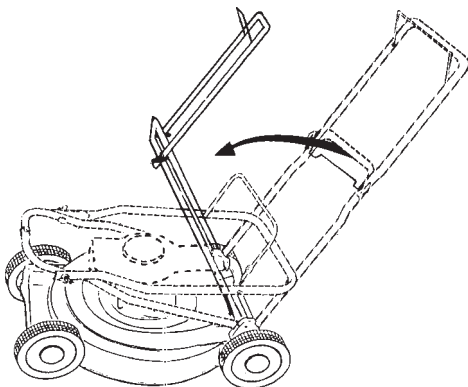

### ENGINE

#### FUEL SYSTEM

**IMPORTANT:** It is important to prevent gum deposits from forming in essential fuel system parts such as carburetor, fuel filter, fuel hose, or tank during storage. Also, experience indicates that alcohol blended fuels (called gasohol or using ethanol or methanol) can attract moisture which leads to separation and formation of acids during storage. Acidic gas can damage the fuel system of an engine while in storage.

- Drain the fuel tank.
- Start the engine and let it run until the fuel lines and carburetor are empty.
- Never use engine or carburetor cleaner products in the fuel tank or permanent damage may occur.
- Use fresh fuel next season.

**NOTE:** Fuel stabilizer is an acceptable alternative in minimizing the formation of fuel gum deposits during storage. Add stabilizer to gasoline in fuel tank or storage container. Always follow the mix ratio found on stabilizer container. Run engine at least 10 minutes after adding stabilizer to allow the stabilizer to reach the carburetor. Do not drain the gas tank and carburetor if using fuel stabilizer.

#### ENGINE OIL

Drain oil (with engine warm) and replace with clean oil. (See “ENGINE” in the Maintenance section of this manual).

#### CYLINDER

- Remove spark plug.
- Pour one ounce (29 ml) of oil through spark plug hole into cylinder.
- Pull starter handle slowly to distribute oil.
- Replace with new spark plug.

#### OTHER

- Do not store gasoline from one season to another.
- Replace your gasoline can if your can starts to rust. Rust and/or dirt in your gasoline will cause problems.
- If possible, store your unit indoors and cover it to protect it from dust and dirt.
- Cover your unit with a suitable protective cover that does not retain moisture. Do not use plastic. Plastic cannot breathe,

which allows condensation to form and will cause your unit to rust.

**IMPORTANT:** Never cover mower while engine and exhaust areas are still warm.

**⚠ CAUTION:** Never store the lawn mower with gasoline in the tank inside a building where fumes may reach an open flame or spark. Allow the engine to cool before storing in any enclosure.

**TROUBLESHOOTING - See appropriate section in this manual unless directed to an authorized service center.**

<b>PROBLEM</b>	<b>CAUSE</b>	<b>CORRECTION</b>
<b>Does not start</b>	<ol style="list-style-type: none"> <li>1. Dirty air filter.</li> <li>2. Out of fuel.</li> <li>3. Stale fuel.</li> <li>4. Water in fuel.</li> <li>5. Spark plug wire is disconnected.</li> <li>6. Bad spark plug.</li> <li>7. Loose blade or broken blade adapter.</li> <li>8. Control bar in released position.</li> <li>9. Control bar defective.</li> <li>10. Fuel valve lever (if so equipped) in OFF position.</li> <li>11. Weak battery (if equipped).</li> <li>12. Disconnected battery connector (if equipped).</li> </ol>	<ol style="list-style-type: none"> <li>1. Clean/replace air filter.</li> <li>2. Fill fuel tank.</li> <li>3. Drain fuel tank and refill tank with fresh, clean gasoline.</li> <li>4. Drain fuel tank and refill tank with fresh, clean gasoline.</li> <li>5. Connect wire to plug.</li> <li>6. Replace spark plug.</li> <li>7. Tighten blade bolt or replace blade adapter.</li> <li>8. Depress control bar to handle.</li> <li>9. Replace control bar.</li> <li>10. Turn fuel valve lever to the ON position.</li> <li>11. Charge battery.</li> <li>12. Connect battery to engine.</li> </ol>
<b>Loss of power</b>	<ol style="list-style-type: none"> <li>1. Rear of lawn mower housing or cutting blade dragging in heavy grass.</li> <li>2. Cutting too much grass.</li> <li>3. Dirty air filter.</li> <li>4. Buildup of grass, leaves, and trash under mower.</li> <li>5. Too much oil in engine.</li> <li>6. Walking speed too fast.</li> </ol>	<ol style="list-style-type: none"> <li>1. Raise cutting height.</li> <li>2. Raise cutting height.</li> <li>3. Clean/replace air filter.</li> <li>4. Clean underside of mower housing.</li> <li>5. Check oil level.</li> <li>6. Cut at slower walking speed.</li> </ol>
<b>Poor cut – uneven</b>	<ol style="list-style-type: none"> <li>1. Worn, bent or loose blade.</li> <li>2. Wheel heights uneven.</li> <li>3. Buildup of grass, leaves and trash under mower.</li> </ol>	<ol style="list-style-type: none"> <li>1. Replace blade. Tighten blade bolt.</li> <li>2. Set all wheels at same height.</li> <li>3. Clean underside of mower housing.</li> </ol>
<b>Excessive vibration</b>	<ol style="list-style-type: none"> <li>1. Worn, bent or loose blade.</li> <li>2. Bent engine crankshaft.</li> </ol>	<ol style="list-style-type: none"> <li>1. Replace blade. Tighten blade bolt.</li> <li>2. Contact a qualified service center.</li> </ol>

**TROUBLESHOOTING (continued) - See appropriate section in this manual unless directed to an authorized service center.**

<b>PROBLEM</b>	<b>CAUSE</b>	<b>CORRECTION</b>
<b>Starter rope hard to pull</b>	<ol style="list-style-type: none"> <li>1. Engine flywheel brake is on when control bar is released.</li> <li>2. Bent engine crankshaft.</li> <li>3. Blade adapter broken.</li> <li>4. Blade dragging in grass.</li> </ol>	<ol style="list-style-type: none"> <li>1. Depress control bar to upper handle before pulling starter rope.</li> <li>2. Contact a qualified service center.</li> <li>3. Replace blade adapter.</li> <li>4. Move lawn mower to cut grass or to hard surface.</li> </ol>
<b>Grass catcher not filling (If so equipped)</b>	<ol style="list-style-type: none"> <li>1. Cutting height too low.</li> <li>2. Lift on blade worn off.</li> <li>3. Catcher not venting air.</li> </ol>	<ol style="list-style-type: none"> <li>1. Raise cutting height.</li> <li>2. Replace blade.</li> <li>3. Clean grass catcher.</li> </ol>
<b>Hard to push</b>	<ol style="list-style-type: none"> <li>1. Grass is too high or wheel height is too low.</li> <li>2. Rear of lawn mower housing or cutting blade dragging in grass.</li> <li>3. Grass catcher too full.</li> <li>4. Handle height position not right for you.</li> </ol>	<ol style="list-style-type: none"> <li>1. Raise cutting height.</li> <li>2. Raise rear of lawn mower housing one (1) setting higher.</li> <li>3. Empty grass catcher.</li> <li>4. Adjust handle height to suit.</li> </ol>