

*Fisher & Paykel*

Freestanding cooker  
OR90SDBGFX models

**Installation instructions  
and User guide**

NZ AU



Safety and warnings	2
Installation instructions	6
Using your seven-function oven for the first time	18
Setting the clock	19
Using your oven	20
Cooking functions	21
Using the rotisserie	23
Using the electronic timer	24
Automatic cooking	25
Using your gas cooktop	26
Care and cleaning	30
Troubleshooting	44
Warranty and service	45

## ***Important!***

### **SAVE THESE INSTRUCTIONS**

*The models shown in this User Guide may not be available in all markets and are subject to change at any time. For current details about model and specification availability in your country, please go to our website [www.fisherpaykel.com](http://www.fisherpaykel.com) or contact your local Fisher & Paykel dealer.*

## 2 Safety and warnings

### Installation

#### WARNING!



##### Electrical Shock Hazard

Always disconnect the cooker from the mains electricity supply before carrying out any maintenance operations or repairs.

Failure to follow this advice may result in death or electrical shock.

#### WARNING!



##### Cut Hazard

Take care - panel edges are sharp.

Failure to use caution could result in injury or cuts.

## *Important safety instructions*

### General

- *To avoid hazard, follow these instructions carefully before installing or using this product.*
- *Please make this information available to the person installing the product as it could reduce your installation costs.*
- *These products are registered:  
in New Zealand at [www.ess.govt.nz](http://www.ess.govt.nz)  
in Australia with AGA at [www.gas.asn.au](http://www.gas.asn.au).*
- *This appliance must be installed in accordance with these installation instructions, local gas fitting regulations, municipal building codes, water supply regulations, electrical wiring regulations, AS/NZS5601.1:2010 - Gas Installations and any other relevant statutory regulations.*
- *Failure to install the cooker correctly could invalidate any warranty or liability claims.*
- *Some appliances have a protective film. Remove this film before using the cooker.*
- *Do not modify this appliance.*
- *Do not operate your appliance by means of an external timer or separate remote-control system.*
- *This appliance is to be installed and serviced only by an authorised person.*

## Electrical

- *This cooker is to be installed and connected to the electricity supply only by an authorised person.*
- *If the installation requires alterations to the domestic electrical system, call a qualified electrician. The electrician should also check that the electrical system is suitable for the electricity drawn by the cooker.*
- *The appliance must be connected to the mains electricity supply, checking that the voltage corresponds to the value given in the rating plate and that the electrical cable sections can withstand the load specified on the plate.*
- *A suitable disconnection switch must be incorporated in the permanent wiring, mounted and positioned to comply with the local wiring rules and regulations. The switch must be of an approved type installed in the fixed wiring and provide a 3 mm air gap contact separation in all poles in accordance with the local wiring rules.  
In Australia and New Zealand, a switch of the approved type with a 3 mm air gap must be installed in the active (phase) conductor of the fixed wiring.*
  
- *The switch must always be accessible.*
- *The power supply cable must not touch any hot parts and must be positioned so that it does not exceed 75 °C at any point.*
- *To connect the cooker to the mains electricity supply, do not use adapters, reducers or branching devices as they can cause overheating and burning.*
- *This cooker must be connected to a suitable double pole control unit adjacent to the cooker. No diversity can be applied to this control unit.*
- *If the electrical supply cord is damaged, it must only be replaced by an authorised person.*
- *This cooker must be connected to electrical supply using V105 insulated cable.*
- *The cooker must be earthed.*

## Power supply

- 220-240V~ 3680W 50/60Hz

## 4 Safety and warnings

### Operation

Your freestanding cooker has been carefully designed to operate safely during normal cooking procedures. Please keep the following guidelines in mind when you are using it:

#### WARNING!



##### Explosion Hazard

Do not store flammable materials such as gasoline near the cooktop.  
Do not store flammable material in the oven or storage compartment.  
Do not spray aerosols near the cooktop during use.  
Failure to follow this advice may result in death or serious injury.

#### WARNING!



##### Electrical Shock Hazard

Switch the cooker off at the wall before replacing fuses or the oven lamp.  
Failure to do so may result in death or electrical shock.

#### WARNING!



##### Hot Surface Hazard

Accessible parts may become hot when this cooker is in use.  
To avoid burns and scalds keep children away.  
Do not touch hot surfaces inside the oven.  
Use oven mitts or other protection when handling hot surfaces such as oven shelves or dishes.  
Take care when opening the oven door.  
Let hot air or steam escape before removing or replacing food.  
Do not touch the cooktop components, burners, trivets/pan supports or the base when hot.  
Before cleaning, turn the cooker off and make sure it is cool.  
Failure to follow this advice could result in burns and scalds.

## ***Important safety instructions***

- *Never leave the appliance unattended when in use. Boilover causes smoking and greasy spillovers that may ignite.*
- *Isolating switch: make sure this cooker is connected to a circuit which incorporates an isolating switch providing full disconnection from the power supply.*
- *Household appliances are not intended to be played with by children.*
- *Children, or persons with a disability which limits their ability to use the appliance, should have a responsible person to instruct them in its use. The instructor should be satisfied that they can use the appliance without danger to themselves or their surroundings.*
- *Safe food handling: leave food in the oven for as short a time as possible before and after cooking. This is to avoid contamination by organisms which may cause food poisoning. Take particular care during warmer weather.*
- *Do not place aluminium foil, dishes, trays, water or ice on the oven floor during cooking as this will irreversibly damage the enamel.*
- *Do not line the walls with aluminium foil.*
- *Do not stand on the door, or place heavy objects on it.*
- *Do not use harsh abrasive cleaners or sharp metal scrapers to clean the oven door glass since they scratch the surface, which may result in shattering of the glass.*
- *Do not use a steam cleaner to clean any part of the cooker.*
- *Do not use an asbestos mat or decorative covers between the flame and the saucepan as this may cause serious damage to your cooktop.*
- *Do not place aluminium foil or plastic dishes on the cooktop burners.*
- *Do not let large saucepans or frying pans overlap the bench as this can deflect heat onto your benchtop and damage the surface.*
- *Do not let large saucepans, frying pans or woks push any other pans aside. This could make them unstable or deflect heat onto your benchtop and damage the surface.*
- *Saucepan handles may be hot to touch. Ensure saucepan handles do not overhang other gas burners that are on. Keep handles out of reach of children.*
- *If the electrical supply cord is damaged, it must only be replaced by an authorised person.*
- *This cooker is not to be used as a space heater, especially if it is installed in marine craft or in a caravan.*
- *The use of a gas cooking appliance results in the production of heat and moisture in the room in which it is installed. Ensure the kitchen is well ventilated. Keep natural ventilation holes open or install a mechanical ventilation device (mechanical extractor hood). Prolonged intensive use of the appliance may call for additional ventilation, for example opening of a window, or more effective ventilation, for example increasing the level of mechanical ventilation where present.*

## 6 Installation instructions

### Dimensions and clearances

Installation clearances and protection of combustible surfaces shall comply with the current local regulations eg. AS/NZS5601.1:2010 Gas Installations code. Installation shall comply with the dimensions in Fig. 1, bearing in mind the following requirements:

#### Overhead Clearances

In no case shall the clearance above the highest part of the cooker be less than 600 mm or, for an overhead exhaust fan, 750 mm. All other downward-facing combustible surfaces less than 600 mm above the cooker surface shall be protected for the full width of the cooking surface in accordance with the standards noted above. In no case shall the clearance be less than 450 mm.

#### Rear and Side Clearances

Where the distance from the periphery of the nearest burner to any vertical combustible surface is less than 200 mm, the surface shall be protected in accordance with the standards to a height of not less than 150 mm above the cooking surface for the full width or depth of the cooking surface.

Where the distance from the periphery of the nearest burner to any horizontal combustible surface is less than 200 mm, the horizontal surface shall be more than 10 mm below the surface of the cooking surface, or the horizontal surface shall be above the trivet (see requirements for vertical combustible surfaces above).

#### Protection of combustible surfaces

The standards above specify that, where required, protection shall ensure that the surface temperature of combustible surfaces does not exceed 65°C above room temperature. Do not install the cooker near flammable materials (eg curtains).

#### Installing the cooker above a plinth without fitting the adjustable feet

In that case the cooker stands directly above the plinth; make sure you provide safety measures to keep it in place. Revise the installation dimensions accordingly considering that the feet have the following measures: min 155 mm - max 180 mm.

If you stand the cooker on a pedestal, make sure you provide safety measures to keep it in place.

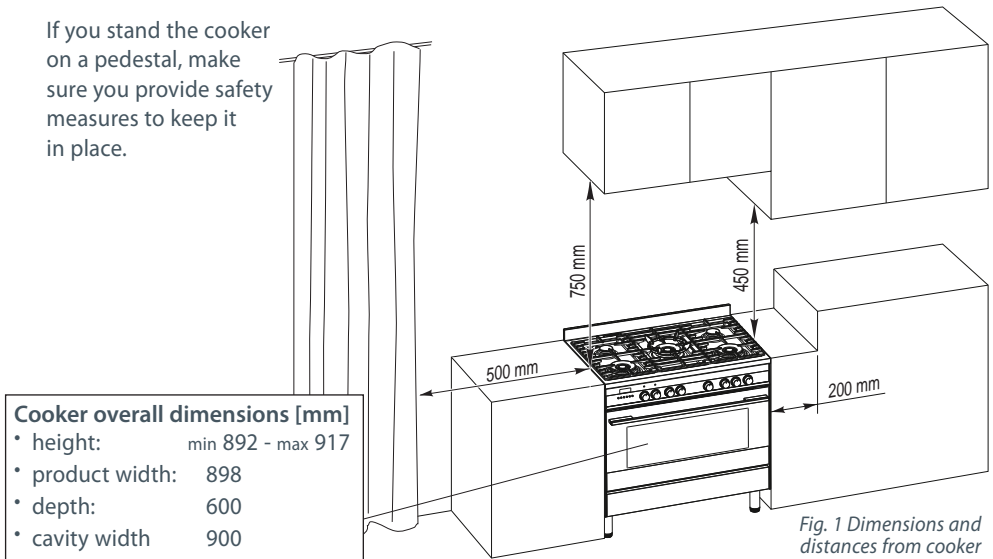

Fig. 1 Dimensions and distances from cooker



## Locating the area for gas and electrical connection

- Area for gas connection
- Area for electrical connection

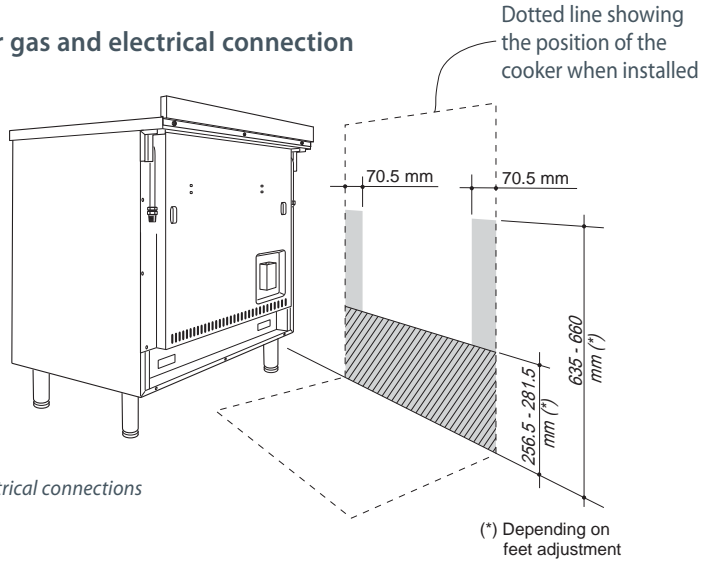

Fig. 2 Area for gas and electrical connections

## Fitting the adjustable feet

### **Important!**

*It is possible to install the cooker above a plinth without fitting the adjustable feet.*

*In that case the cooker will stand directly above the plinth; make sure you provide safety measures to keep it in place.*

Fit the adjustable feet before using the cooker.

- 1 Rest the rear of the cooker on a piece of the polystyrene packaging, exposing the base for fitting the feet.
- 2 Fit the four feet by screwing them tight into the support base as shown.

## Levelling the cooker

Level the cooker by screwing the feet in or out, as shown in Fig.5.

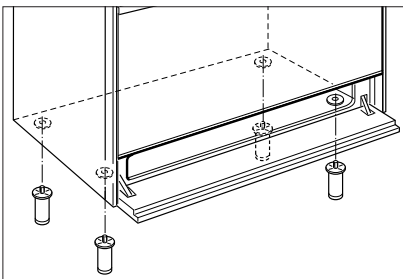

Fig. 3 Location of feet

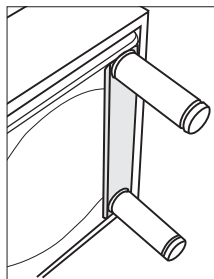

Fig. 4 Top of feet to be screwed in tightly

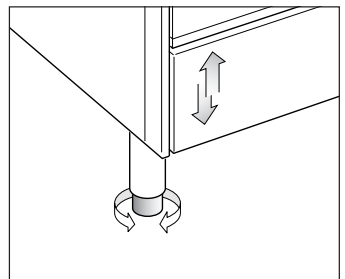

Fig. 5 Levelling the cooker

## Moving the cooker

### **Important!**

To prevent damaging the adjustable feet, ensure the cooker is always lifted by two people.

Do not lift the cooker by the door handles.  
DO NOT DRAG the cooker. Lift the feet clear of the floor.

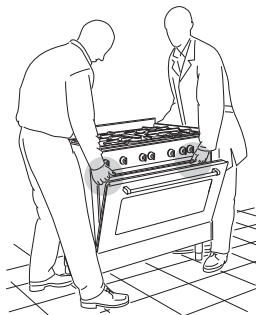

Fig. 6 Correctly lifting the cooker



Fig. 7 Incorrectly moving the cooker

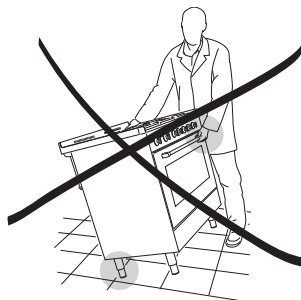

Fig. 8 Incorrectly lifting the cooker

## Fixing the backguard

Before installing the cooker, assemble the backguard "C".

- The backguard "C" can be found packed at the rear of the cooker.
- 1 Before assembling, remove any protective film/adhesive tape.
  - 2 Remove the two spacers "A" and the screw "B" from the rear of the cooktop.
  - 3 Assemble the backguard as shown and fix it by screwing the central screw "B" and the spacers "A".

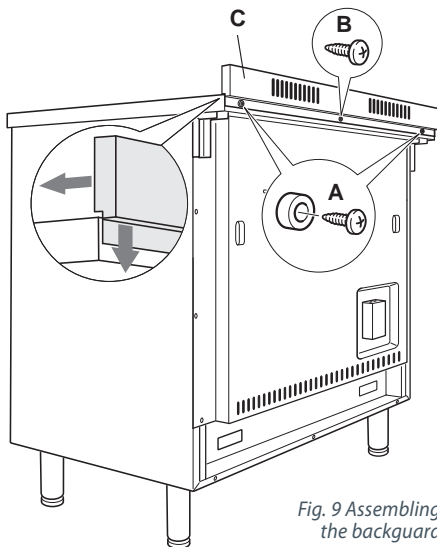

Fig. 9 Assembling the backguard

## Fitting the anti-tilt bracket

### **Important!**

To restrain the appliance and prevent it tipping accidentally, fit a bracket to its rear to fix it securely to the wall. Make sure you also fit the supplied lock pin to the anti-tilt bracket.

If installing the cooker above a plinth (without fitting the adjustable feet), revise the installation dimensions accordingly considering that the feet have the following measures: min 155 mm - max 180 mm.

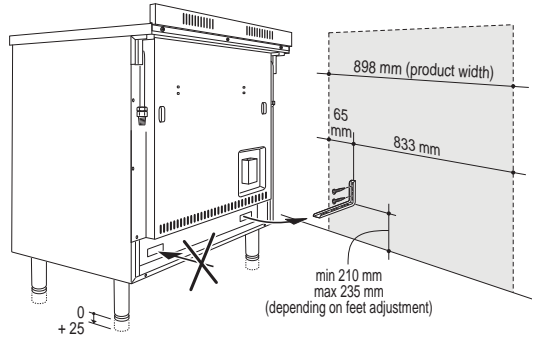

Fig. 10a Fitting the anti-tilt bracket

To fit the anti-tilt bracket:

- 1 After you have located where the cooker is to be positioned, mark on the wall the place where the two screws of the anti-tilt bracket have to be fitted. Please follow the indications given in Fig.10a.
- 2 Drill two 8 mm diameter holes in the wall and insert the plastic plugs supplied.

### **Important!**

Before drilling the holes, check that you will not damage any pipes or electrical wires.

- 3 Loosely attach the anti-tilt bracket with the two screws supplied.
- 4 Move the cooker to the wall and adjust the height of the anti-tilt bracket so that it can engage in the slot on the cooker's back, as shown in Fig.10a.
- 5 Tighten the screws attaching the anti-tilt bracket.
- 6 Push the cooker against the wall so that the anti-tilt bracket is fully inserted in the slot on the cooker's back.
- 7 Access the bracket and fit the lock pin;
  - Open the pivoting panel (Fig. 10b).
  - Fit the lock pin through the bracket, as shown (Fig.10c).
  - Close the pivoting panel.

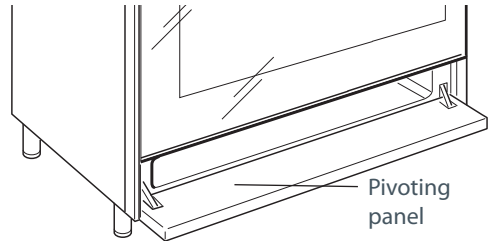

Fig. 10b Opening the pivoting panel

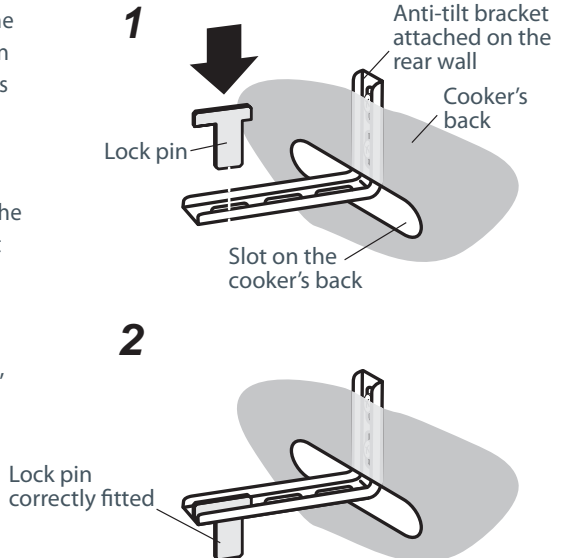

Fig. 10c Fitting the lock pin through the bracket

## Connecting the cooker to the gas supply

- The gas connection must be carried out by an authorised person according to the relevant standards.
- Before connecting the appliance to the gas main, mount the brass conical adaptor onto the gas inlet pipe, upon which the washer has been placed (see Figs 11-12 following). Conical adaptor and washer are supplied with the appliance (packed with conversion kit for use with Natural gas or LPG).
- This appliance is suitable for use with Natural gas or LPG. (Check the “gas type” sticker attached to the appliance).
- For Natural gas, connect the gas supply to the gas pressure regulator which is supplied with the appliance (Fig.12). Adjust the regulator to obtain a test point pressure of 1 kPa with the two semi-rapid burners operating at the maximum.
- For LPG, connect the gas supply to the test point adaptor which is supplied with the appliance (Fig.11). Ensure that the supply pressure is regulated to 2.75 kPa.
- The connection must be made at the rear of appliance (left or right); the pipe is not to cross the cooker.
- Close off the unused inlet with the cap and sealing washer supplied (Fig. 13).
- **IMPORTANT:** Use two spanners to tighten or loosen the connecting pipe (Fig.13).

### Installation with a flexible hose assembly

- If this appliance has to be installed with a hose assembly, the installer shall refer to the network operator or gas supplier for confirmation of the gas type, if in doubt.
- When used with a flexible hose, the connector on the wall should be between 450 mm to 500 mm from the floor and 200 mm to 300 mm from the left-hand side of the appliance as viewed from the front. The hose connection on the appliance shall face downwards.
- It is important that the hose does not come in contact with the metal of the appliance and is secured as per appropriate gas installation codes. A chain 80% of the length of the flexible gas hose must be used to prevent stress being applied to the hose. The chain should be attached securely to the product where shown (see Fig.13), and on the wall.
- Flexible hose assemblies should be AS/NZS 1869 Class B or Class D certified. The thread connection shall be Rp ½” (ISO 7-1) male.
- **Important!**  
*After connection the installer must check that the hose is not kinked, subjected to abrasion or permanently deformed. The installer must check also that the hose is not near or in contact with any hot surfaces.*
- The hose assembly shall be as short as practicable and comply with relevant AS5601 / NZS5261 requirements.

## Gas connection for LPG

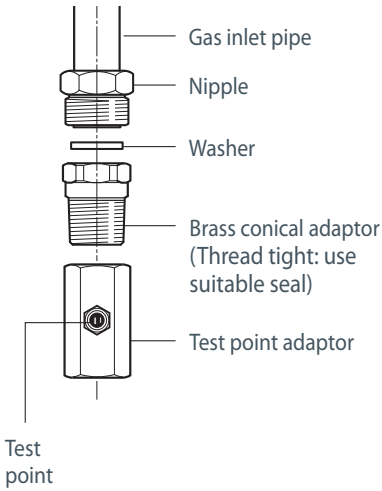

Fig. 11 LPG connection

## Gas connection for NATURAL GAS

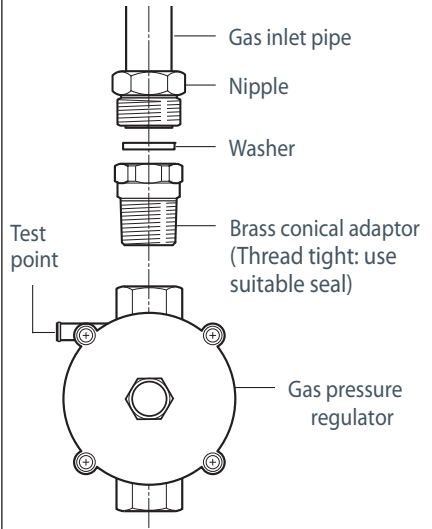

Fig. 12 Natural gas connection

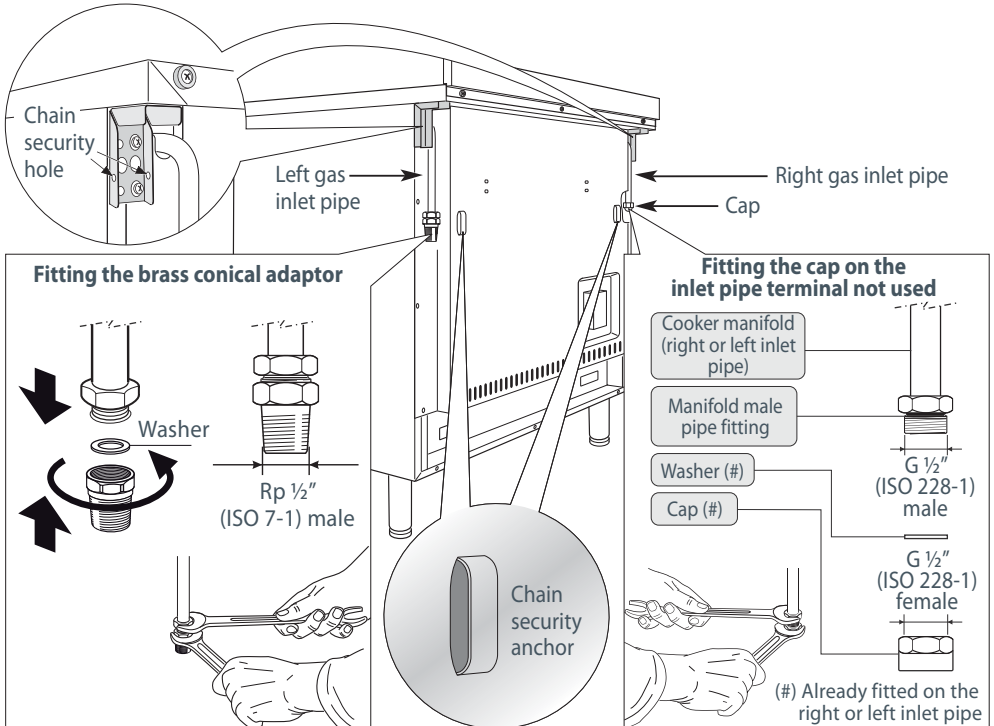

Fig. 13 Gas supply inlets

## Leak-testing and flame-testing the cooker

After installing the freestanding cooker and connecting the gas supply:

- 1 Using a suitable leak detection fluid solution, check each gas connection one at a time by brushing the solution over the connection.

The presence of bubbles will indicate a leak. If there is a leak, tighten the fitting and then recheck for leaks.

**Important!** *Do not use a naked flame to test for leaks.*

- 2 Adjust the test point pressure or supply pressure to the value that is appropriate for the gas type.
- 3 Test the operation of the appliance:
  - Turn on the appliance gas controls and light each burner individually and in combination. Check for a well-defined blue flame without any yellow tipping. If any abnormality is evident, then check that the burner cap is located properly and the injector nipple is aligned correctly.
  - Check the minimum burner setting by quickly rotating the gas control dial from the maximum to the minimum position. The flame must not go out. If you need to adjust the setting, see 'Adjusting the minimum burner setting' following.
- 4 If satisfactory performance cannot be obtained, the installer shall check the installation and notify the local gas supply authority for a gas supply problem, or if it is an appliance problem, our Customer Service Centre should be called to obtain the nearest authorized Service Agent.

## Converting to a different gas type

This appliance is suitable for use with Natural gas or LPG (check the "gas type" sticker attached to the appliance). To convert from one gas type to another, you need to replace the injectors, and then adjust the minimum burning setting.

### Replacing the injectors

- 1 Remove the trivets and burners from the cooktop.
- 2 Using a spanner, remove the injectors (shown in Figs. 14-15-16 following) and replace them with ones according to the gas type (see the 'Table for the choice of injectors').
- 3 Fix the warning label (supplied with the conversion kit) at the back of the cooker, near the gas inlet connections. This label states that the gas cooktop has been converted for use with LPG/ Natural gas.

### Adjusting the minimum burner setting

- 4 Follow the instructions on Page 14, 'Adjusting the minimum burner setting'.

### **Important!**

- *If you are converting the cooker from Natural gas to LPG, remove the gas pressure regulator before connecting the cooker to the gas supply and replace with the test point adaptor supplied with the conversion kit.*
- *If you are converting the cooker from LPG to Natural gas, remove the test point adaptor before connecting the cooker to the gas supply and replace with the gas pressure regulator supplied with the conversion kit.*

Notes:

- The burners are designed so that regulation of primary air is not required.

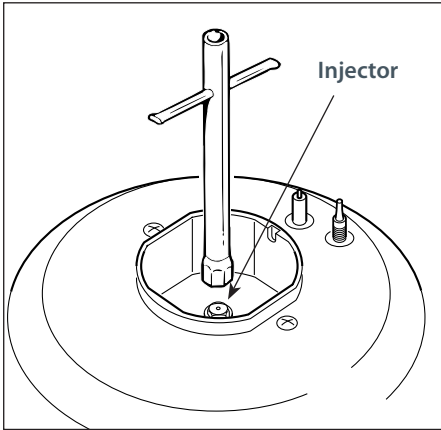

Fig. 14 Semi-rapid burner

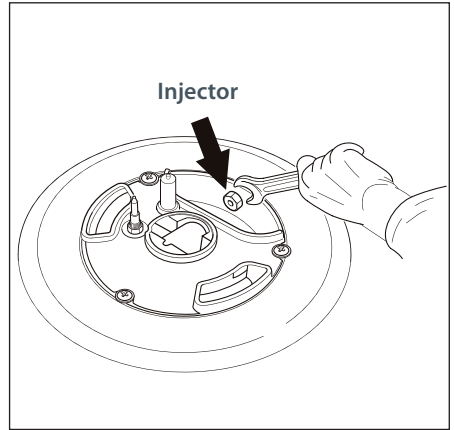

Fig. 15 Triple-ring wok burner

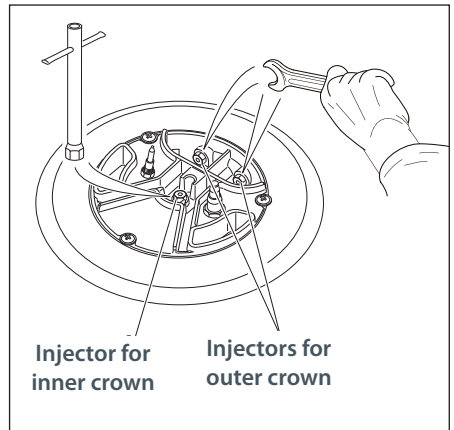

Fig. 16 Dual burner

## Adjusting the minimum burner setting

Check whether the flame spreads to all burner ports when the burner is lit with the gas valve set to the minimum position.

If some ports do not light, increase the minimum gas rate setting. Check whether the burner remains lit even when the gas valve is turned quickly from the maximum to the minimum position.

If the burner does not remain lit, increase the minimum gas rate setting.

To adjust the minimum gas rate setting:

### Semi-rapid and triple-ring burners:

- 1 Turn on the burner.
- 2 Turn the valve to the MINIMUM position.
- 3 Take off the dial.
- 4 Using a small flat screwdriver, turn the screw (see Fig. 17) to the correct regulation.

### Inside crown of dual burner:

- 1 Turn on the burner.
- 2 Turn the valve to the MINIMUM position of the inner crown only.
- 3 Take off the dial.
- 4 Using a small flat screwdriver, turn the screw (see Fig. 18) to the correct regulation.

### Outside crown of dual burner:

- 1 Turn on the burner.
- 2 Turn the valve to the MINIMUM position of the inner and outer crowns.
- 3 Take off the dial.
- 4 Using a small flat screwdriver, turn the screw (see Fig. 18) to the correct regulation.

Note: for LPG, the regulation screw is normally tightened up.

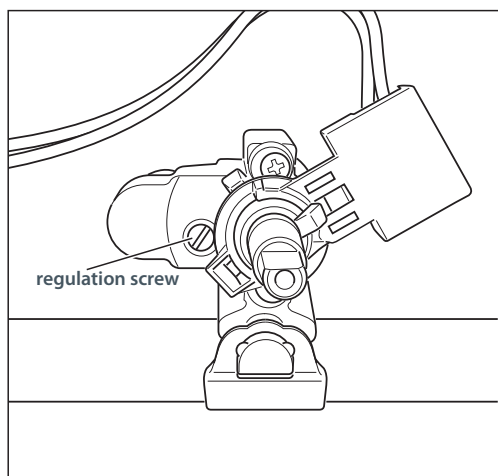

Fig. 17 Adjusting the minimum burner setting: semi-rapid and triple-ring wok burner

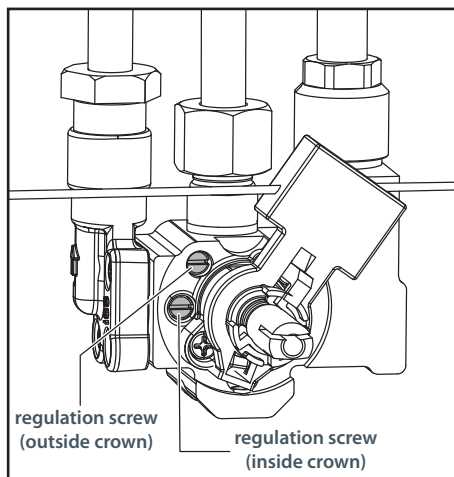
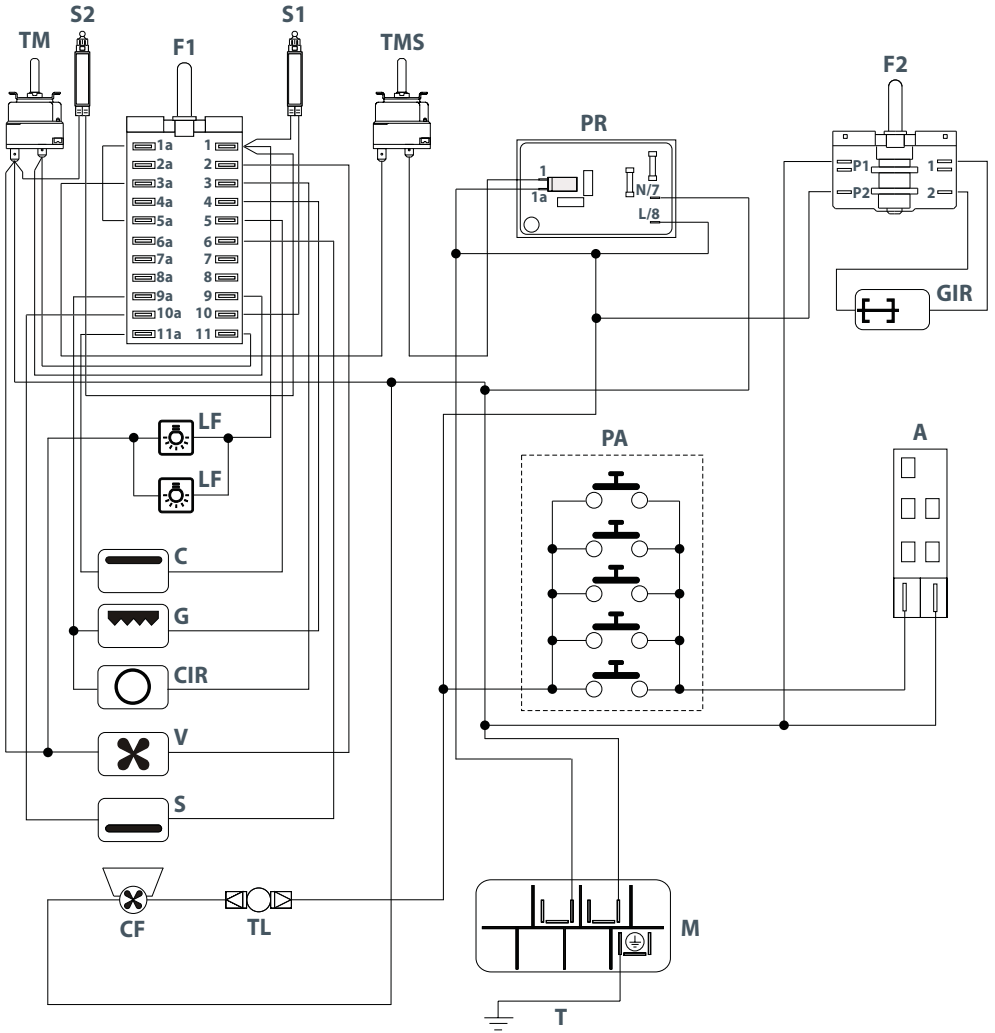

Fig. 18 Adjusting the minimum burner setting: dual burner



	<b>Natural gas</b>		<b>LPG</b>	
Test Point Pressure [kPa]	1.0		2.75	
BURNER	Injector Orifice Dia. [mm]	Gas Consumption [MJ/h]	Injector Orifice Dia. [mm]	Gas Consumption [MJ/h]
Semi-rapid	1.17	6.50	0.70	6.30
Triple-ring wok	1.54	11.88	0.98	12.00
Dual	0.76 (inner crown)	16.20 (inner and outer crowns operating)	0.50 (inner crown)	16.20 (inner and outer crowns operating)
	1.23 - no.2 (outer crown)		0.73 - no.2 (outer crown)	

Wiring diagram



## Wiring diagram key

<b>F1</b>	Oven function selector (switch)
<b>TM</b>	Oven thermostat
<b>TMS</b>	Safety thermostat
<b>TL</b>	Thermal overload (n.o.)
<b>S1</b>	Oven temperature indicator light
<b>S2</b>	Oven ON indicator light
<b>PR</b>	Oven programmer
<b>F2</b>	Rotisserie selector (switch)
<b>GIR</b>	Rotisserie motor
<b>LF</b>	Oven lamps
<b>S</b>	Oven bottom heating element
<b>C</b>	Oven top heating element
<b>G</b>	Oven grill heating element
<b>CIR</b>	Oven fan (circular) heating element
<b>V</b>	Oven fan motor
<b>CF</b>	Cooling fan motor
<b>PA</b>	Ignition switches harness
<b>A</b>	Igniter
<b>M</b>	Terminal block
<b>T</b>	Earth connection

## Using your seven-function oven for the first time

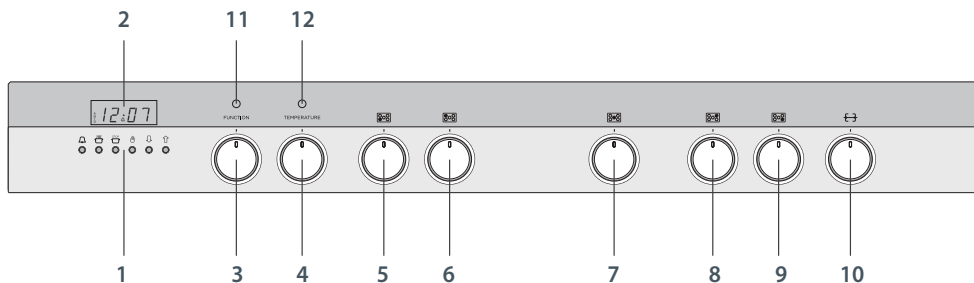





Fig. 19 Control panel

- |  |   |
|--|---|
| 1 Control buttons                          | 7 Central (dual) burner dial            |
| 2 Clock display                            | 8 Rear right (semi-rapid) burner dial   |
| 3 Function dial                            | 9 Front right (triple-ring) burner dial |
| 4 Temperature dial                         | 10 Rotisserie dial                      |
| 5 Front left (triple-ring wok) burner dial | 11 Function indicator light             |
| 6 Rear left (semi-rapid) burner dial       | 12 Temperature indicator light          |

### Before using your new oven, please:

- 1 Read this user guide, taking special note of the 'Safety and warnings' section.
- 2 Remove all accessories and packaging. Peel the protective film off all surfaces and accessories.
- 3 Set the clock. The oven will not work until the clock has been set.
- 4 Slide in the shelves you will need, making sure that:
  - they are between the two wires of a shelf position;
  - the stop notches point down;
  - the guard rail is at the back.
  - Note: the grill tray should be positioned between the two wires of a shelf position and orientated as shown.
- 5 Heat the oven on maximum for:
  - 60 minutes in the  position
  - 30 minutes in the  position
  - 15 minutes in the  position
  - There will be a distinctive smell while you are conditioning your oven. This is normal, but make sure your kitchen is well ventilated during the conditioning.

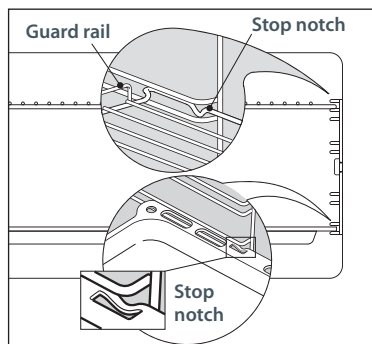







Fig. 20 Correct position of shelves and grill tray

- 6 Once cooled, wipe out the oven with a damp cloth and mild detergent, and dry thoroughly.

## Buttons

-  sets the timer
-  sets the cooking time for automatic cooking
-  sets the stop time for automatic cooking
-  sets the clock, returns oven to manual mode, cancels automatic cooking
-  decreases time and beep volume
-  increases time

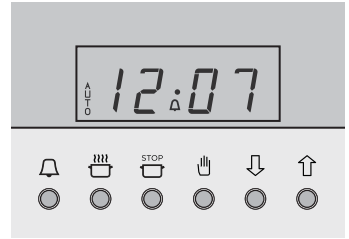







Fig. 21 Clock display and control buttons

## Illuminated symbols

If the display shows	It means that...	Fore more information
<b>A</b> flashing with 	The clock needs to be set.	See instructions below.
<b>U</b> steadily lit	The oven is set for automatic cooking.	
<b>T</b> <b>O</b> flashing and beeping	Automatic cooking has finished or has been set incorrectly (the stop time is before the time of day)	See section 'Automatic cooking'
 steadily lit	The timer is set	
 flashing and beeping	The time is up	See section 'Using the electronic timer'

## To set the clock

When the power to the appliance is turned on or restored after a power failure,  and AUTO will flash in the display.

- 1 Press .
- 2 Press  and  until you have the correct time of the day.

## 20 Using your oven

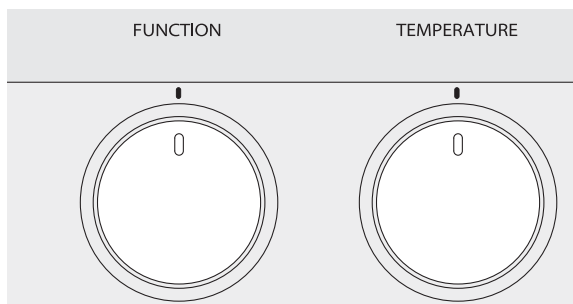

Fig. 22 Function and temperature dials

- 1 Select the function by turning the function dial. The oven lights will come on.
- 2 Select the temperature by turning the temperature control dial clockwise. The oven temperature indicator light, above the temperature dial on the control panel, will glow until the oven has reached the set temperature, and then it will go out. Note: the temperature indicator light may glow and go out again during cooking as the oven maintains the set temperature.
- 3 When you have finished cooking, turn the function and temperature control dials to the 0 (off) position.

Note: press the  button if **AUTO** is flashing or steadily illuminated.



## OVEN LAMP

Only the oven light comes on. It remains on in all the cooking functions.



## BAKE

The upper and lower heating elements come on. BAKE is the traditional method of cooking. It is best to cook on only one shelf at a time in this function. Ideal for large cakes and dishes that bake for several hours.



## GRILL

Grill is the most suitable function for 'finishing off' many meals, for example browning the top of potato gratin and frittata. Use Grill to toast bread or to grill your favourite chicken, fish and steak. Use with the oven door closed and the temperature set to a maximum of 225°C. For best results, use the topmost shelf position when you want quick browning (eg toast).



## DEFROST

Only the oven fan comes on. Use with the temperature dial set to 0 (off). The fan circulates air around the oven, speeding up the defrosting process by approximately 30%.  
Note: this function is not for cooking food.



## FAN FORCED

The circular heating element and the fan come on. The oven set on FAN FORCED can cook several different foods together. Use FAN FORCED for multi-shelf cooking.



## FAN GRILL

Both the grill and the fan come on. Use with the oven door closed and the temperature set to a maximum of 225°C. Ideal for roasting tender cuts of meat and poultry. Use lower shelf positions for larger items eg a whole chicken.



## PASTRY BAKE

Excellent for sweet and savoury pastry foods, for moist breads and brownies and cookies that you want extra chewy.



## FAN BAKE

The upper and lower heating elements and the fan come on. Ideal for dishes like lasagne that need to brown on top and also single trays of small cakes or biscuits that bake in less than an hour.

### **Important!**

*Safe food handling: leave food in the oven for as short a time as possible before and after cooking or defrosting. This is to avoid contamination by organisms which may cause food poisoning. Take particular care during warmer weather.*

## 22 Cooking functions

### Notes on baking:

- Preheat the oven before baking.
- Do not place anything, including water or ice, on the oven floor.
- Remove the fat filter before baking.
- Use the fat filter when roasting meat and poultry on FAN BAKE, FAN GRILL or FAN FORCED. It helps to keep your oven clean and reduces splatter and smoking.
- Always clean the filter after every use. See 'Care and cleaning'.
- Remove the fat filter before baking.

### Baking chart

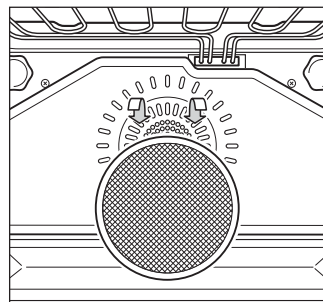

Fig. 23 Fat filter

- The settings in the following chart are guidelines only. Follow the instructions in your recipe or on packaging and be prepared to adjust the oven settings and baking times to achieve the best possible results for you.
- Shelf positions are counted from the oven floor up (1 is the lowest, 4 or 6 the highest).
- Arrange oven shelves before you turn the oven on, then preheat the oven to the required temperature (until the temperature indicator light goes out).
- Single shelf positions below use the flat oven shelf; where a multi shelf arrangement is recommended, the higher position uses the step-down shelf.
- Due to the width of the oven, a single shelf can usually accommodate double the standard recipe.

Food	Note on arrangement	Shelf position(s)	Best function	Temperature (°C)	Time
Small cakes	single shelf	2	<b>Bake</b>	180-190	20-30 mins
	multi shelf	1 and 3	<b>Fan Forced</b>	160-170	30-40 mins
Scones	single shelf	2	<b>Bake</b>	210-230	15-20 mins
	multi shelf	1 and 3	<b>Fan Forced</b>	210-230	15-20 mins
Sponge	two small pans (20 cm), on single shelf	2	<b>Bake</b>	170-180	30-45 mins
	one large pan (26 cm)	2	<b>Bake</b>	175	30-40 mins
Light fruit cake	two pans (21 cm) on single shelf	2	<b>Bake</b>	155-165	1 hr 30 mins
Rich fruit cake	exact baking time will depend on size	2	<b>Bake</b>	130-150	3-6 hrs
Apple pie	single shelf	1	<b>Bake</b>	185	35-45 mins
Custard tart	single shelf	1	<b>Bake</b>	180-200, then 140-150	15, then 30-40 mins
Quiche	single shelf	1	<b>Bake</b>	180-200	30-40 mins
Meringues	single shelf	1	<b>Bake</b>	100-120	1 hr
Bread rolls	single shelf	1	<b>Bake</b>	210-230	15-20 mins
Muffins	2 x 12 muffin trays on single shelf	3	<b>Fan Forced or Fan Bake</b>	190-200	10-15 mins
Pastry case (baked 'blind')	one 21 cm flan tin	1	<b>Pastry Bake</b>	200	10 mins with beans, then 10 mins without



- 1 Prepare the rotisserie supports.
  - Place the grill tray on the benchtop.
  - Insert the supports into the lock studs.
  - Push the supports all the way down to lock them in firmly.
- 2 Secure the meat.

## **Important!**

**Take care, the forks are sharp!**

When securing the meat, ensure that:

- the skewer goes through the centre of the meat
- the forks hold the meat firmly in place
- the fork screws are tightened
- there are no loose or projecting parts. Poultry should be trussed.

Note: the rotisserie can rotate up to 6 kg of meat.

- 3 Position the skewer on the supports.
  - Place the skewer on the supports, and check that the meat does not touch the grill tray.
  - Twist the handle off. It must not be left in the oven.
- 4 Place the rotisserie in the oven.
  - Slide the grill tray all the way to the back on shelf position 1.
  - Push the skewer through the hole cover on the right-hand wall of the oven, then insert it fully into the rotisserie drive hole.
- 5 Start the rotisserie
  - Check that the fat filter is in place.
  - Select the FAN GRILL function.
  - Set the temperature to 180 °C.
  - Turn the the rotisserie dial to ①.

## **Important!**

- Always ensure that poultry is cooked thoroughly.
- During use, the rotisserie components become hot. If you leave the oven door open after using the rotisserie, parts of the control panel may also become hot. Use oven mitts and take extra care, especially when removing the rotisserie support rack from the hot oven.
- Always clean the fat filter after every use. See 'Care and cleaning'.

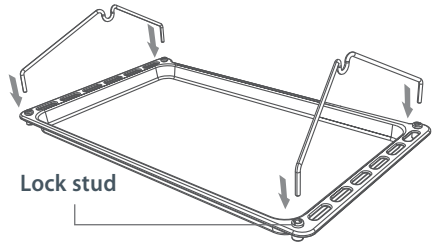

Fig. 24a Prepare the rotisserie supports

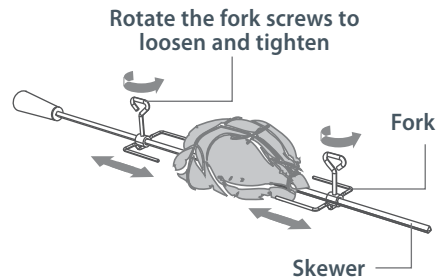

Fig. 24b Secure the meat

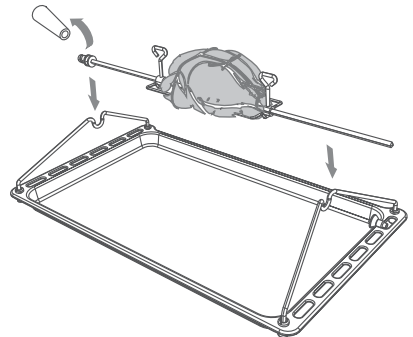

Fig. 24c Position the skewer on the supports

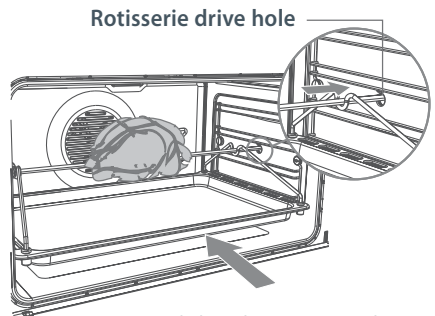

Fig. 24d Place the rotisserie in the oven







## 24 Using the electronic timer

You can use the timer at any time, even when the oven is not in use.

### **Important!**

*The timer does NOT turn the oven off.*



### To set the timer

- 1 Press .  will show and the  symbol will start flashing.
  - 2 Press  and  to set the time you want (up to 23 hours and 59 minutes, in 1-minute steps).
- After a few seconds, the clock will show the time of day within the  symbol steadily lit. The timer is now counting down.



### To check the remaining time

Press .

### To cancel the timer

- 1 Press .
  - 2 Press  until the time is reset to .
- After a few seconds, the clock will show the time of day

### When the set time is up

- The timer will beep and the  symbol will flash. Press  to stop the beeping and turn the timer off.
- After a few seconds, the clock will show the time of day.

### To adjust the beep volume

Press  to hear the next volume level. The last one selected will be stored.

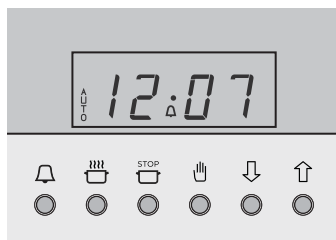





Fig. 25 Clock display and control buttons

## To set the oven for automatic cooking



### 1 Set the oven:

- Check the clock shows the correct time (eg 12:07).
- Select the function and set the temperature.  
The oven will turn on.

### 2 Set the cooking time:

- Decide how long the food will take to cook, allowing time for preheating if necessary (eg 40 minutes).
- Press .
- Use  and  to set the cooking time. AUTO will show in the display.

### 3 Set the stop time:

- Decide when you want your food to be ready by (eg 13:30).
- Press .
- Use  and  to set the stop time.

You can turn the oven on manually and set it to turn off automatically by setting the stop time (step 3 above).

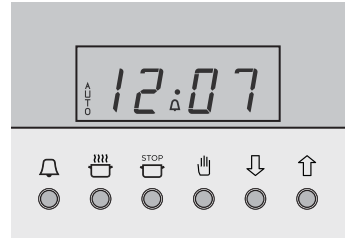





Fig. 26 Clock display and control buttons

## When automatic cooking is set

- If there is time before cooking starts, the oven will turn off and the current time of day and AUTO will show in the clock display, indicating that the oven is set for automatic cooking. Note: the cooling fan may stay on.
- The oven will automatically turn on at the required time (eg 12:50) and turn off at the set stop time (eg 13:30).
- To see the remaining cooking time, press .
- To see the set stop time, press .
- To cancel automatic cooking, press  and turn the function and temperature dials to 0 (off).

## When the stop time is reached

- The oven will turn off, the timer will beep and AUTO will flash.
- 1 Press  to stop the beeping and return the oven to manual mode.
  - 2 Turn the function and temperature dials to 0 (off).

## 26 Using your gas cooktop

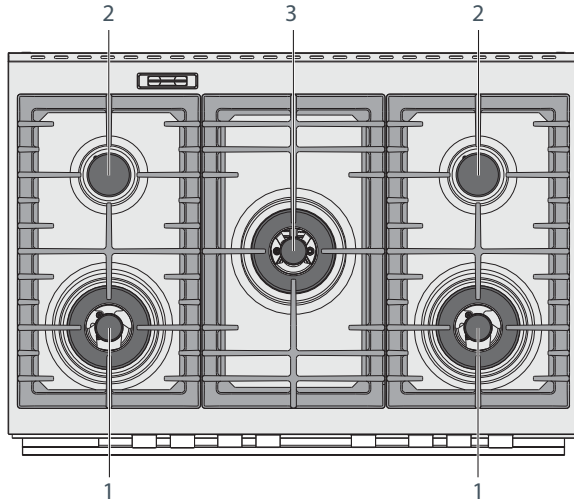

Fig 27 Cooktop layout

- 1 Triple-ring wok burner
- 2 Semi-rapid burner
- 3 Dual burner

### Gas burners

The dial controls the flow of gas through the safety valve.

#### Semi-rapid and triple-ring wok burners

- ○ = closed valve (OFF)
  - ● = maximum flow of semi-rapid and triple-ring burner burners
  - ● = minimum flow of semi-rapid and triple-ring burner burners
- You can choose to cook at any heat between ● and ●, but never between ● and ○ (OFF).

#### Dual burner

- ○ = closed valve (OFF)
- ● = maximum flow of inner crown only (turn dial clockwise)
- ● = minimum flow of inner crown only (turn dial clockwise)
- ● = maximum flow of inner & outer crowns (turn dial anticlockwise)
- ● = minimum flow of inner & crowns (turn dial anticlockwise)

You can choose to cook at any heat between ● and ● or between ● and ●, but never between ● and ○ (OFF) or between ● and ○ (OFF).

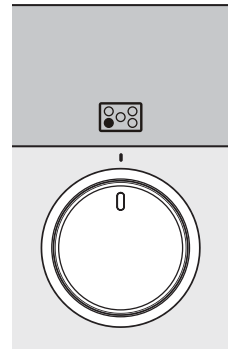















Fig. 28 Burner control dial

## Before using your cooktop

Before using your new cooktop, please:

- Read this user guide, taking special note of the 'Safety and warnings' section.
- Turn the power to the cooker on at the wall.
- Make sure all burner control dials are turned off.

## Using the gas burners

- 1 Choose the control dial for the burner you want to use.
- 2 **Semi-rapid and triple-ring burners:** press the dial in gently and turn it anticlockwise to the  position. The ignitors on all the burners will spark.  
**Dual burner:** press the dial in gently and turn it anticlockwise to the  position (to ignite the inner and outer crowns) or press the dial in gently and turn it clockwise to the  position (to ignite the inner crown only). The ignitors on all the burners will spark.  
Hold in the dial for approximately 10 seconds after the burner has lit. Releasing the dial too soon will extinguish the flame.
- 3 Adjust the flame anywhere between  and  or  or  and  or  and  positions. Do not adjust the flame between  or  or  and 0 (OFF).
- Note: If the burner does not light within 15 seconds, turn the control dial off and wait at least one minute before trying again.
- 4 To turn the burner off, turn the dial clockwise (semi-rapid and triple-ring burners or dual burner when using both crowns) or anticlockwise (dual burner when using the inner crown only) to 0 (OFF) until you hear the safety click.
- 5 After use, always turn the dials to the 0 (OFF) position.

## Flame failure safety feature

The flame failure probe cuts off the gas supply to the burner if the flame is blown out.

When lighting the burner on flame failure models, hold down the dial for approximately 10 seconds after the burner has lit. Releasing the dial too soon will extinguish the flame.

If the flames are accidentally extinguished, turn off the burner and do not try to light it again for at least one minute (to allow the gas to disperse).

### If a burner does not light

Check that:

- The cooker is plugged in and the electricity is switched on.
- The gas is turned on.
- The gas bottle is not empty (if you are using bottled gas).
- You have held down the dial for at least 10 seconds.
- The ignitors are sparking. If the ignitors are not sparking, they may be dirty or wet. Clean them with a toothbrush and methylated spirits, as shown in Fig.31.

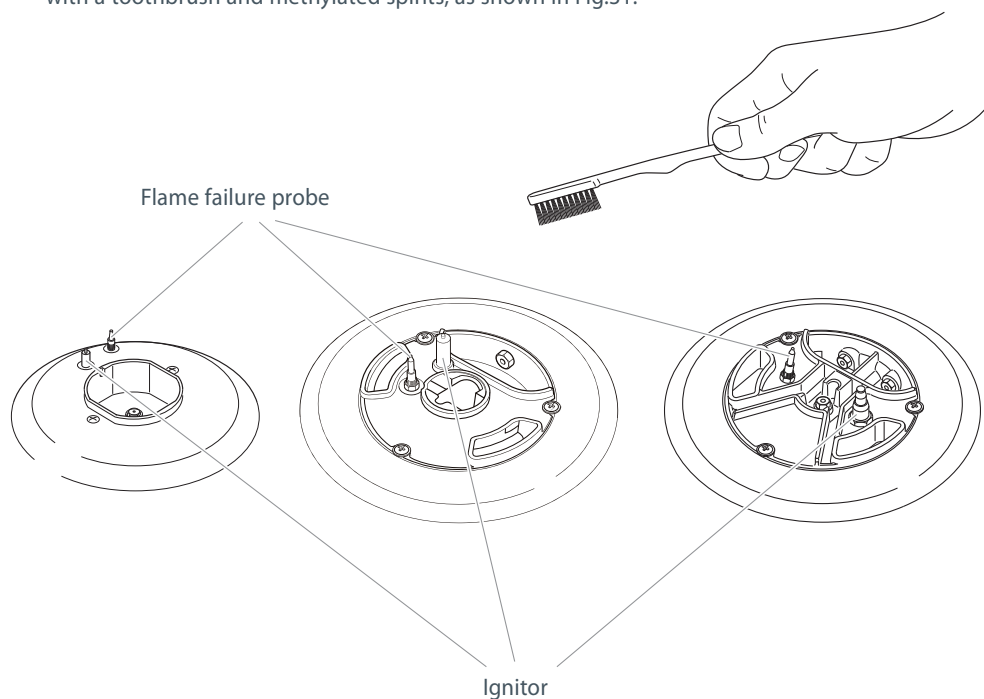

Fig. 29 Cleaning the probe and ignitor

### If the flame is irregular

If the flame is yellow or irregular, check that the burner parts, including the burner cap, are:

- clean and dry.
- positioned correctly. See 'Care and cleaning'.
- See also 'Cooktop troubleshooting'.

## Matching cookware to burner

Use flat-bottomed pans, and make sure they match the size of the burner, as shown in the following table. A small pot on a large burner is not efficient.

### Diameters of pans which may be used on the cooktop

Burners	Minimum	Maximum
Semi-rapid	16 cm	24 cm
Triple-ring wok	26 cm	28 cm
	Maximum diameter for woks 36 cm	
Dual (inner crown only)	12 cm (6 cm with small pan support)	14 cm
Dual (inner and outer crowns)	26 cm	28 cm
	Maximum diameter for woks 36 cm	

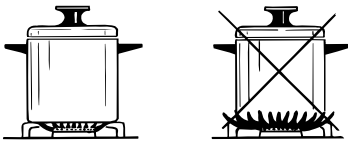

Fig. 30 Correct and incorrect matching of cookware and burner size



Fig. 31 Efficient and inefficient saucepan bottoms

## Small pan support

This pan support is to be placed on top of the dual burner when using small diameter pans, in order to prevent them from tipping over. Use the burner with the inner crown only.



Fig. 32 Small pan support

## Wok stand

The wok stand fits over the triple-ring wok or dual burner trivet.

### Important!

- Using a wok without the stand may cause the wok to tip or the wok or dual burner to operate incorrectly.
- Do not use the stand for ordinary, flat-bottomed saucepans.
- The wok stand **MUST BE PLACED ONLY** over the trivet for the triple-ring wok or dual burner.
- The cooktop becomes very hot during operation. Keep children well out of reach.

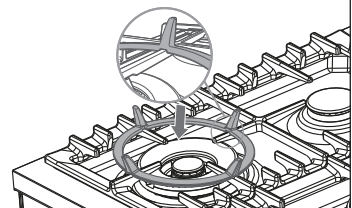
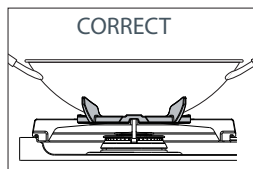
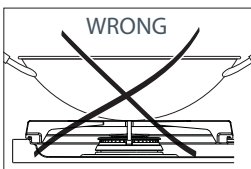

Fig. 33 Correct placement of wok stand

**Important!**

*Before you start cleaning your cooker, please:*

- *Read these cleaning instructions and the 'Safety and warnings' section at the start of this user guide.*
- *Turn the cooker off at the wall.*
- *Make sure the cooker is a safe temperature to touch.*
- *Do not use a steam cleaner.*
- *Do not keep flammable substances in the oven.*

**General advice**

- Wipe down the cooktop and wipe out the oven after every use.
- Wipe up spills. Avoid leaving alkaline or acidic substances (such as lemon juice or vinegar) on the surfaces.
- Do not use cleaning products with a chlorine or acidic base.

**Cleaning the outside of the cooker****Important!**

- *Do not use abrasive cleaners, cloths or pads on the outside surfaces.*
- *Immediately wipe off any caustic cleaners if they are spilled onto the oven door handle.*

Wipe the outside surfaces often, using warm water and a mild household detergent. The stainless steel may also be cleaned with a suitable cleaner and polish.

Note: if you choose to use a commercial stainless steel cleaner, please read the label to make sure it does not contain chlorine compounds as these are corrosive and may damage the appearance of your cooker.

**Cleaning the gas cooktop**

Maintenance Period	Description
Daily	• Clean gas cooktop as per following instructions.
Monthly	• Remove all burner parts, and clean using a non-abrasive detergent. Rinse in cold water, dry thoroughly, and replace. • Clean the ignitor carefully, using a toothbrush and methylated spirits.
Every 3-4 years	• Contact your local authorised gas Service Agent to perform a thorough check on all gas components on the gas cooker.



### Burner parts and trivets

- You can remove and clean these parts with hot soapy water or non-abrasive detergents. Clean spills regularly before they become burnt on. Do not wash these parts in a dishwasher.
- After cleaning, check that the burners and their flame spreaders are dry before replacing correctly.
- It is very important to check that the burner flame spreader and the cap have been correctly positioned. Failure to do so can cause serious problems.
- Note: to avoid damage to the electronic ignition, do not try to light a burner without all burner parts in place.

### Replacing the semi-rapid burners

- Carefully replace the burner parts as per the following Figs. Check that:
  - the ignitor is always clean to ensure trouble-free sparking.
  - The probe is always clean to ensure correct operation of the safety valves (some models only)
 Note: both the ignitor and probe must be very carefully cleaned using a toothbrush and methylated spirits (see Fig.29).

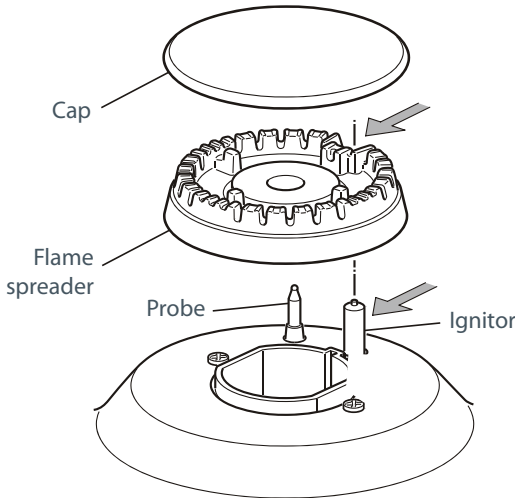

Fig. 34 Correct line-up of semi-rapid burner parts

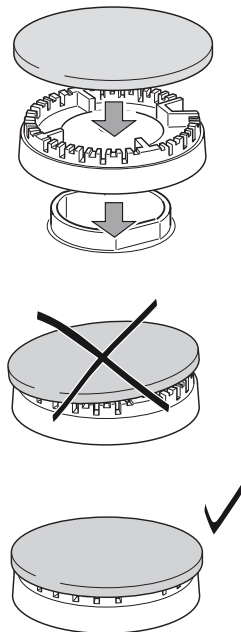

Fig. 35 Replacing the semi-rapid burner caps

### Replacing the triple-ring wok and dual burners

- Carefully replace the burner parts as per the following Figs.  
Fit the flame spreader to the housing as shown by the arrow in the Figs.36a-36b. Make sure the burner is not able to rotate (Fig. 37).

Check that:

- the ignitor is always clean to ensure trouble-free sparking.
  - The probe is always clean to ensure correct operation of the safety valves (some models only)
- Note: both the ignitor and probe must be very carefully cleaned using a toothbrush and methylated spirits (see Fig.29).

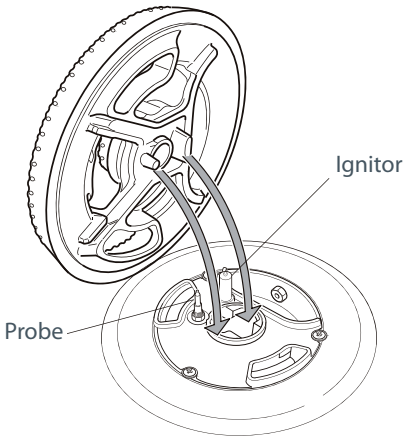

Fig. 36a Correct positioning of flame spreader - triple-ring wok burner

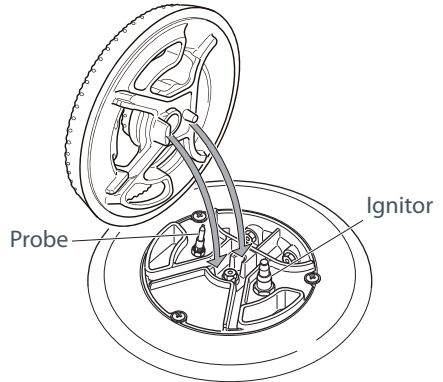

Fig. 36b Correct positioning of flame spreader - dual burner

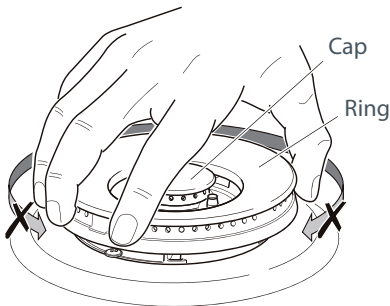

Fig. 37 Correct positioning of cap and ring - triple-ring wok and dual burner

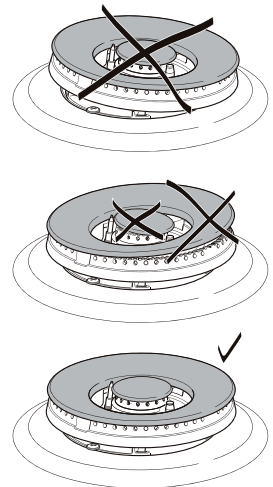

Fig. 38 Incorrect and correct positioning of cap and ring - triple-ring wok and dual burner

## Cleaning the inside of your oven

- Do not use abrasive cleaners, cloths or pads to clean the enamel.
- To make cleaning easier, you can remove the side racks, the oven door, and the fat filter.

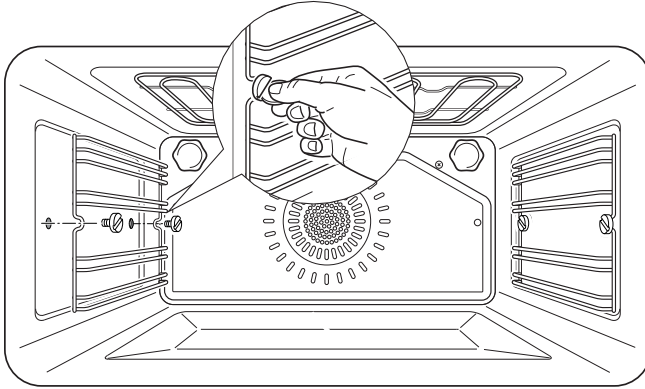

Fig. 39 Removing the side racks

### Drop-down grill element

- To lower the grill element: use a flat-head screwdriver or a small coin to loosen the element fixing screws.
- When you have finished cleaning the oven ceiling, raise the grill element and screw the element fixing screws back onto the studs. Make sure that the fixing screws are tightened and the element is held securely in place. The grill element itself is self-cleaning.

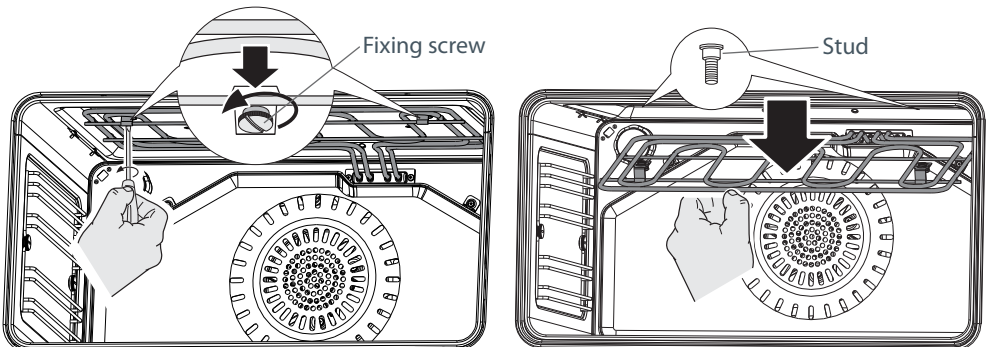

Fig.40 Drop-down grill element

### Cleaning the enamel cavity

Clean the enamel on the inside of the oven when it has cooled down, using household detergents or an ammonia-based cleaner. You may use 'off the shelf' oven cleaners, if you carefully follow the manufacturers' instructions.

### Cleaning the fat filter

Clean the fat filter after every use. If the filter is not cleaned, it will block and shorten the life of the fan element. If the filter is lightly soiled, place it in a dishwasher on normal wash. If the filter is very dirty, place in a saucepan with either two tablespoons of clothes washing powder, or one tablespoon of dishwashing powder. Bring to the boil and leave to soak for at least 30 minutes. Rinse the filter in clean water and dry.

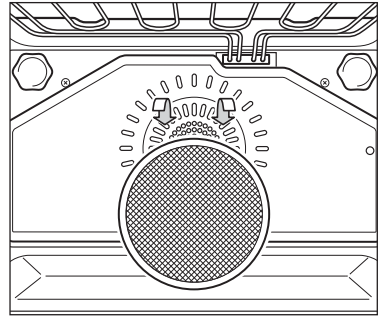

Fig. 41 Fat filter

### Cleaning the grill tray and shelves

Clean these in hot, soapy water.

After cleaning slide in the shelves, making sure that:

- they are between the two wires of a shelf position;
- the stop notches point down;
- the guard rail is at the back.
- Note: the grill tray should be positioned between the two wires of a shelf position and orientated as shown.

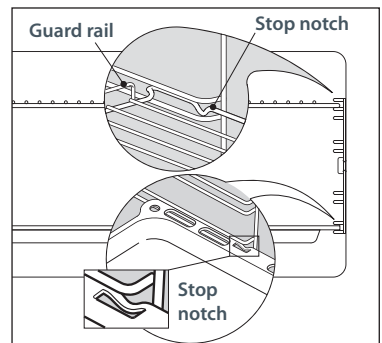

Fig. 42 Oven shelves and grill tray

## Fitting and removing the sliding shelf supports

When fitting the sliding shelf supports, make sure that you fit:

- the side racks first
- the slides to the top wire of a shelf position
- both sides of each pair of slides
- both slides on the same level.

### **Important!**

*Remove the side racks first to make removing the sliding shelf supports easier.*

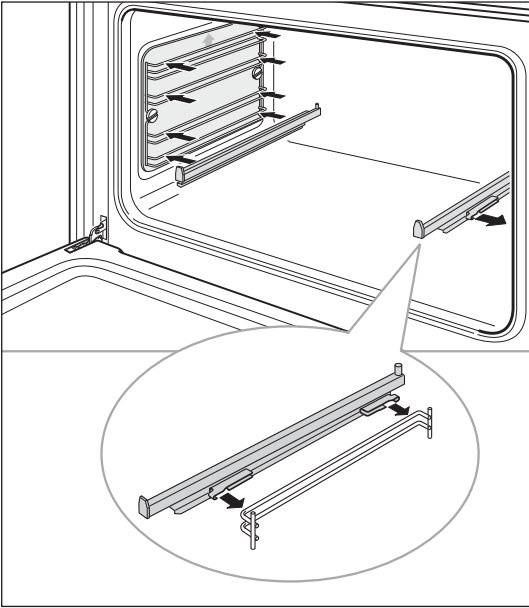

Fig. 43a Fitting the sliding shelf supports

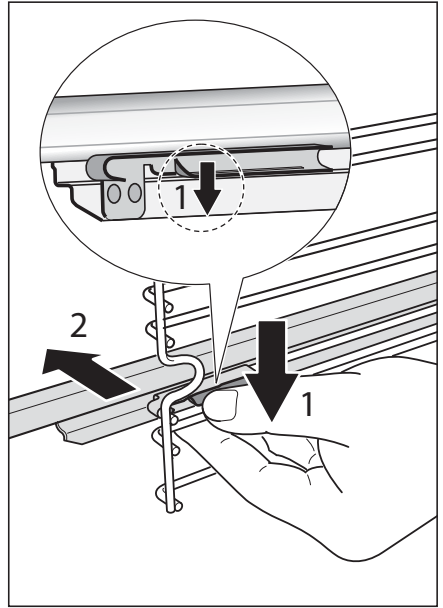

Fig. 43b Removing the sliding shelf supports

### Storage compartment

The storage compartment is accessible through the pivoting panel (Fig.44).

#### **Important!**

*Do not store flammable material in the oven or in the storage compartment.*

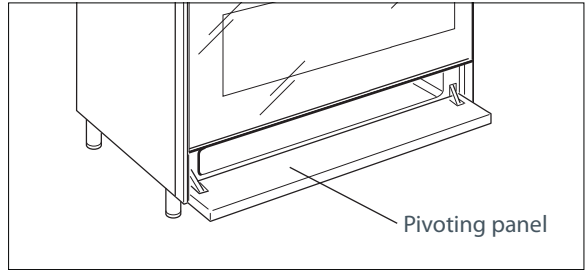

Fig. 44 Storage compartment

### Replacing the oven lamp

- 1 Turn the power to the cooker off at the wall.
- 2 Let the oven cavity and the heating elements cool down.
- 3 Twist the lamp cover off.
- 4 Remove and replace the halogen lamp with a new one suitable for high temperatures (300°C) with the following specifications: 220-240V, E14 and same wattage as the lamp being replaced (25W).

#### **Important!**

*Never replace the bulb with bare hands; contamination from your fingers can cause premature failure. Always use a clean cloth or gloves.*

- 5 Twist the lamp cover back on
- 6 Set the clock.

Note: oven bulb replacement is not covered by your warranty.

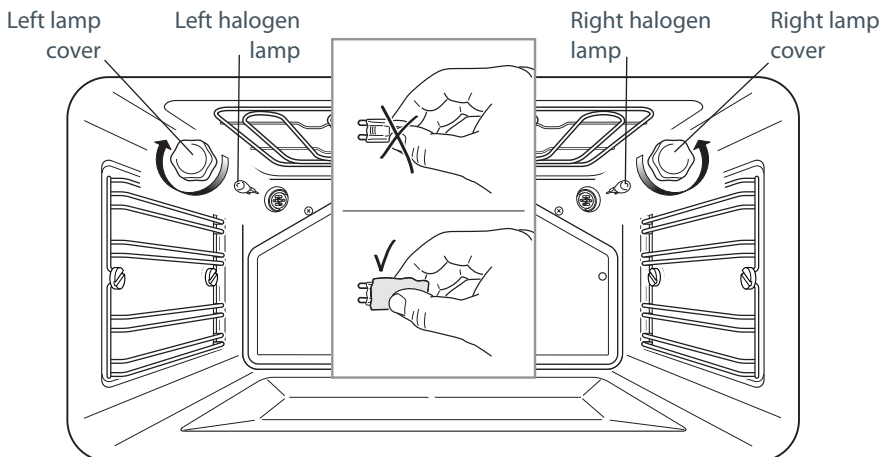

Fig.45 Replacing the oven lamp

## Removing and replacing the inner door glass pane for cleaning

If you wish to clean the inner glass of the door, make sure you follow the precautions and instructions very carefully.

Replacing the glass pane and the door incorrectly may result in damage to the appliance and may void your warranty.

### ***Important!***

- Take care, the oven door is heavy. If you have any doubts, do not attempt to remove the door.
- Make sure the oven and all its parts have cooled down. Do not attempt to handle the parts of a hot oven.
- Take extreme care when handling the glass pane. Avoid the edges of the glass bumping against any surface. This may result in the glass shattering.
- ***CAUTION: Do not use harsh abrasive cleaners or sharp metal scrapers to clean the oven door glass since they can scratch the surface, which may result in shattering of the glass.***
- If you notice any sign of damage on any of the glass panes (such as chipping, or cracks), do not use the oven. Call your Authorised Service Centre or Customer Care.
- Make sure you replace the glass pane correctly. Do not use the oven without glass pane correctly in place.
- If the glass pane feels difficult to remove or replace, do not force it. Call your Authorised Repairer or Customer Care for help.
- Note: service visits providing assistance with using or maintaining the oven are not covered by your warranty.

## Removing the oven door

The oven door can easily be removed as follows:

- Open the door to the full extent (fig. 46a).
- Open the lever 'A' completely on the left and right hinges (fig. 46b).
- Hold the door as shown in fig. 46e.
- Gently close the door (fig. 46c) until left and right hinge levers 'A' are hooked to part 'B' of the door (fig. 46b).
- Withdraw the hinge hooks from their location following arrow 'C' (fig. 46d).
- Rest the door on a soft surface.

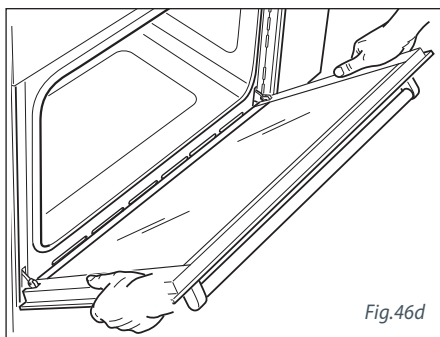
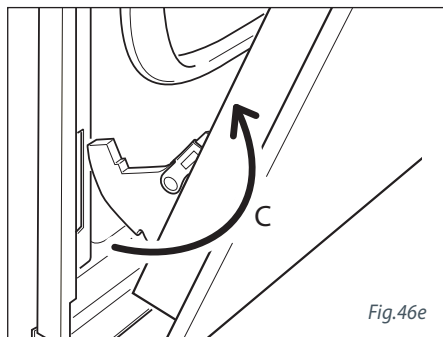
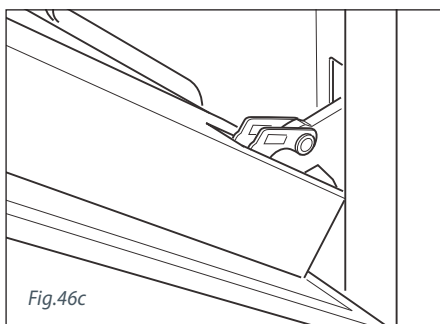
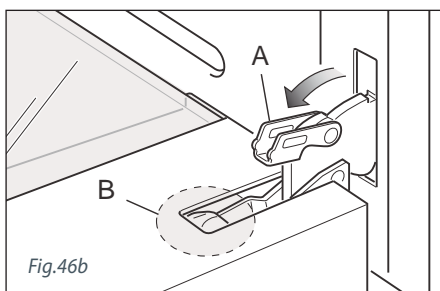
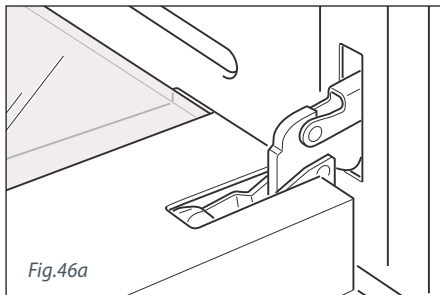



## Removing the inner pane of glass

The oven door is fitted with no. 2 panes:

- no. 1 outside;
- no. 1 inner.

To clean all panes on both sides it is necessary to remove the inner pane as follows:

### Remove the inner glass retainer

- 1 Remove the oven door and place it on a soft surface.  
*IMPORTANT: The door shall be placed horizontally as per Fig. 47.*
- 2 Press down on both tabs to release the glass retainer.
- 3 Remove the glass retainer.

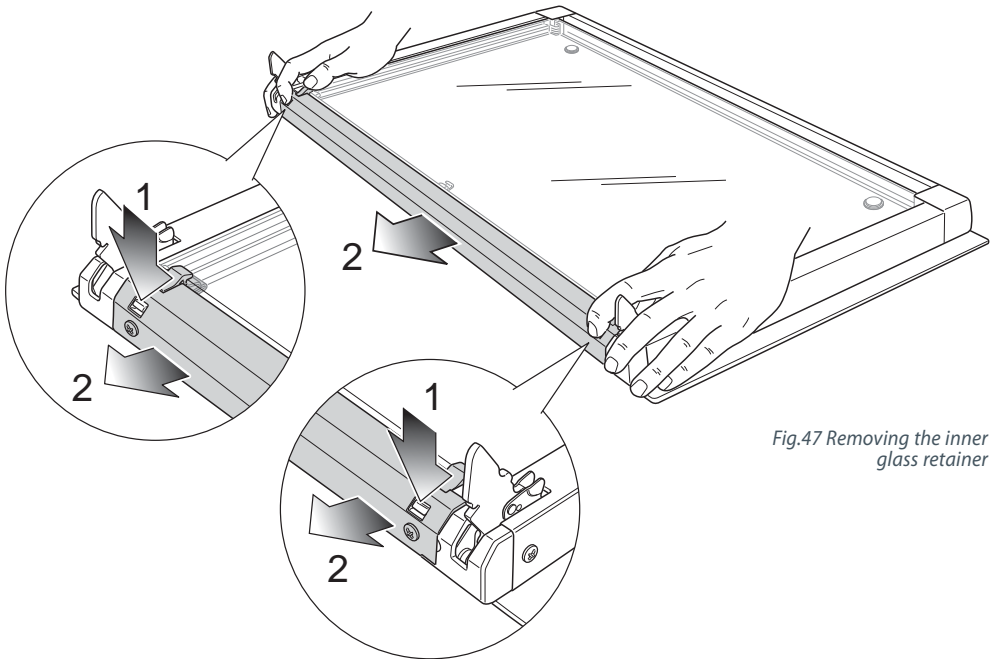
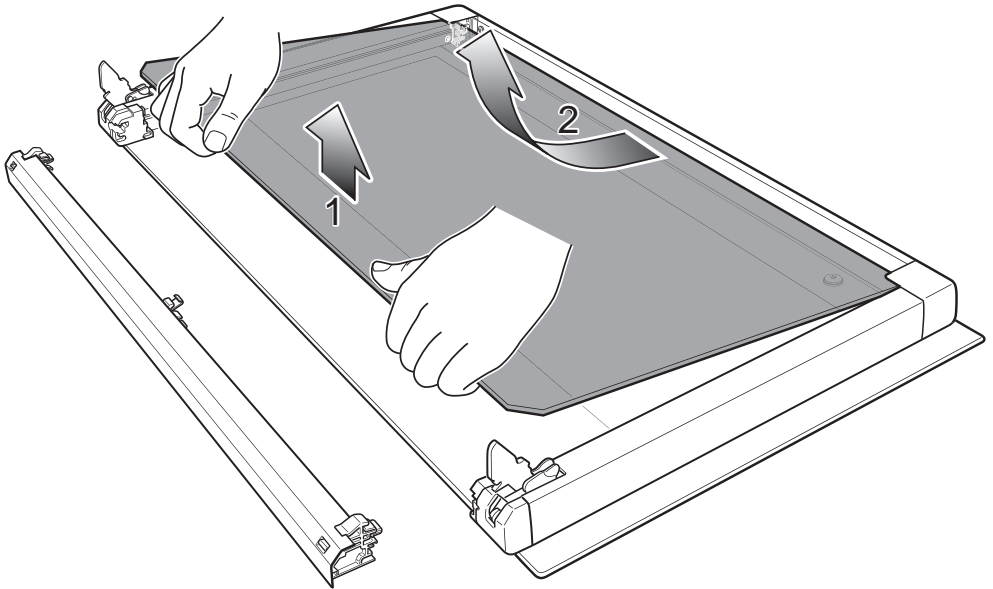

Fig.47 Removing the inner glass retainer

## 40 Care and cleaning

### Remove the inner glass pane

Lift and remove the inner pane slightly, as shown in the figure 48.



*Fig.48 Removing the inner glass pane*

## After cleaning, replace the inner glass pane

When replacing the inner glass pane, make sure that:

- You replace the pane correctly, as shown. The pane must be in the position described below in order to fit into the door and to ensure that the appliance operates safely and correctly.
- You take extra care not to bump the edges of the glass against any object or surface.
- You do not force the pane into place. If you are experiencing difficulties replacing the pane, remove it and start the process again from the beginning. If this still does not help, call Customer Care.
- Check that you are holding the pane the correct way. You should be able to read the wording on it as it faces you.
- Check that the gasket 'A' is in place (Fig. 49). If not, correctly place the gasket in the top edge of the inner glass (in the centre).

- 1 Insert the inner glass pane in the uppermost pair of grooves and push it slightly (arrow 1 in figure 49).
- 2 Gently lower into place (arrow 2 in figure 49).

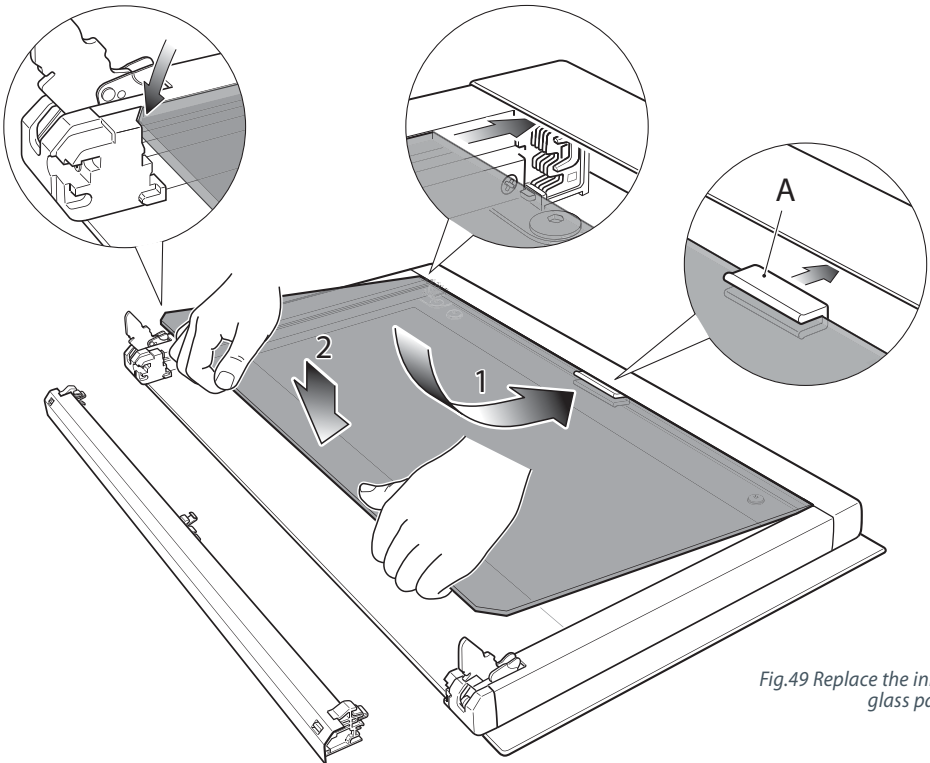

Fig.49 Replace the inner glass pane

### Replace the glass retainer

- 1 Position the glass retainer, as shown in the figure 50. It should sit on the bottom edge of the outer glass. Check that the clamps 'M' are not deformed or damaged.
- 2 Gently push the glass retainer back into place. You should be able to hear the tabs on both sides click as they lock the glass retainer in.

### **Important!**

*Make sure the glass retainer is correctly and firmly in place and that the glass pane is secure.*

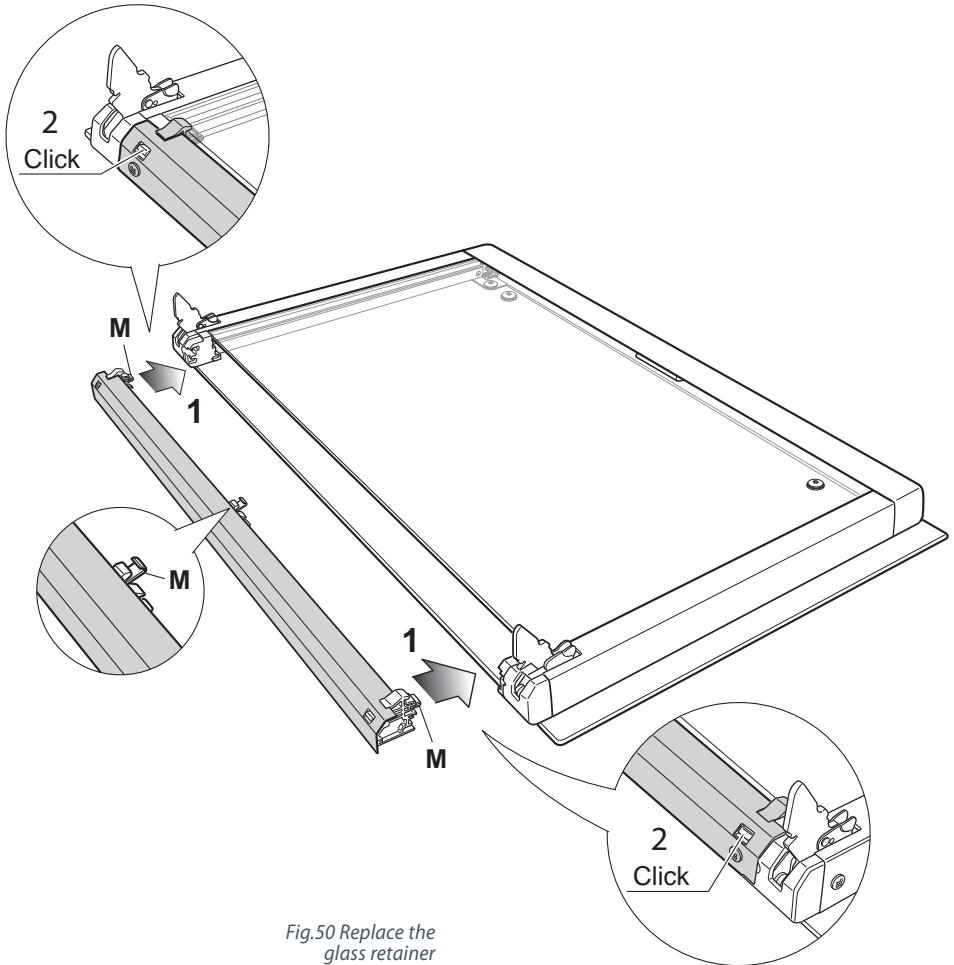
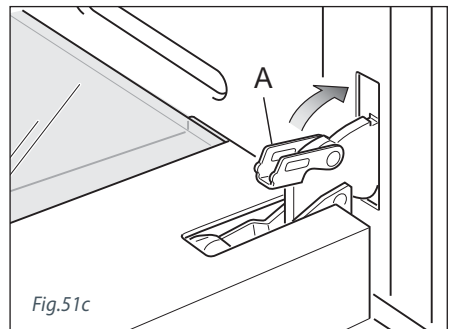
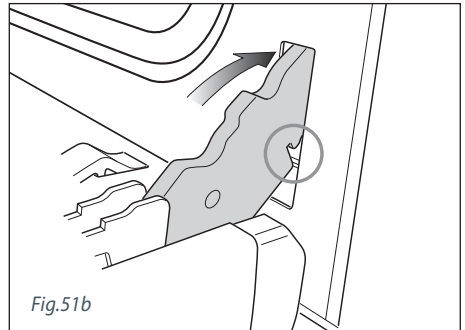
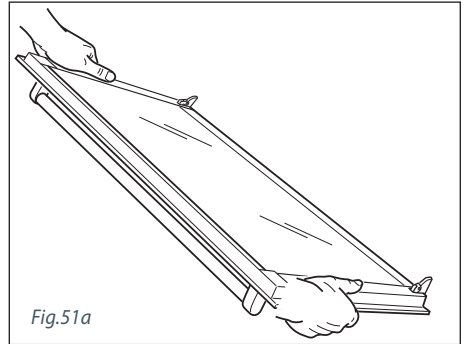

Fig.50 Replace the glass retainer

## Refit the door

- 1 Hold the door firmly (fig.51a).
- 2 Insert the hinge tongues into the slots, making sure that the groove drops into place as shown in the figure 51b.
- 3 Open the door to its full extent.
- 4 Fully close the levers 'A' on the left and right hinges, as shown in the figure 51c.
- 5 Close the door and check that it is properly in place.



Problem	Possible solutions
A burner does not light.	<p>Check the cooker is switched on at the wall.</p> <p>Check the gas supply valve is turned on and the supply to the house is working. You should hear the gas when you turn a burner on.</p> <p>Check the gas bottle is not empty.</p> <p>The ignitors may be dirty. Clean them with a toothbrush and methylated spirits.</p> <p>The burner parts may not be located properly. Check the assembly and make sure the burner cap is sitting flat.</p>
My burner flames are yellow or hard to start.	<p>The burner parts may not be located properly. Check the assembly and make sure the burner cap is sitting flat.</p> <p>If you use bottled gas, this may indicate you are getting near the end of the bottle.</p> <p>Check the burner parts are clean and dry.</p> <p>The gas pressure may not be at the correct level. Check with your service person or installer.</p> <p>Your cooker may not be set up for the gas you are using. Check this with your service person or installer.</p>
One of my burners has an uneven flame.	<p>Check the burner parts are clean and dry. Check the assembly and make sure the burner cap is sitting flat.</p>
The flame goes out at low settings.	<p>The gas supply pressure may be low. Check this with your service person or installer.</p> <p>The low setting may have been adjusted incorrectly. Check this with your service person or installer.</p> <p>If you use bottled gas, this may indicate you are getting near the end of the bottle.</p>
My burners do not turn down much (when running on bottled gas or LPG).	<p>Your cooktop may not have been adjusted correctly. Check this with your service person or installer.</p>
The flame tips are very yellow.	<p>Call your service person to service the cooker.</p>
There are objectionable odours.	<p>Call your service person to service the cooker.</p>
The flame appears to lift off the burner.	<p>Call your service person to service the cooker.</p>
There is an electricity failure.	<p>If there is an electricity failure, you can still use your cooktop. Light the burners by holding a match close to the side of the burner and turning the control dial to the High position. Wait until the flame is burning evenly before adjusting.</p>

## Before you call for service or assistance ...

Check the things you can do yourself. Refer to the installation instructions and your user guide and check that:

- 1 Your product is correctly installed.
- 2 You are familiar with its normal operation.

If after checking these points you still need assistance, please refer to the Service & Warranty book for warranty details and your nearest Authorised Service Centre, or contact us through our website:

**[www.fisherpaykel.com](http://www.fisherpaykel.com)**

This cooker has been designed and constructed in accordance with the following codes and specifications:

In New Zealand and Australia:

AGA101 (AS 4551) Approval Requirements for Domestic Gas cooking appliances

AS/NZS 60335-1 General Requirements for Domestic electrical appliances

AS/NZS 60335-2-6 Particular Requirements for Domestic electrical cooking appliances

AS/NZS 1044 Electromagnetic Compatibility Requirements.

## Product details

Fisher & Paykel Ltd

**Model** ..... **Serial No.** .....

**Date of Purchase** ..... **Purchaser** .....

**Dealer** ..... **Suburb** .....

**Town** ..... **Country** .....











[www.fisherpaykel.co.nz](http://www.fisherpaykel.co.nz)  
[www.fisherpaykel.com.au](http://www.fisherpaykel.com.au)

***Fisher & Paykel***

Copyright © Fisher & Paykel 2012. All rights reserved.

The product specifications in this booklet apply to the specific products and models described at the date of issue. Under our policy of continuous product improvement, these specifications may change at any time. You should therefore check with your Dealer to ensure this booklet correctly describes the product currently available.