

LTH

SERIES

12LTH36

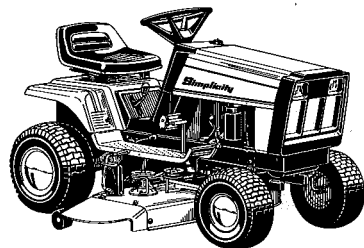

OPERATOR'S
MANUAL

This manual covers the following Manufacturer's Numbers:

12LTH: MFG. NO. 1691931

36" MOWER: MFG. NO. 1691419

Table of Contents

SAFETY RULES	2	SHARPENING & BALANCING THE BLADES	23
DECALS	5	CHECK TRANSMISSION FLUID LEVEL	25
MOWER INSTALLATION AND REMOVAL	6	TRACTOR OFF-SEASON STORAGE	26
OPERATION	10	MOWER OFF-SEASON STORAGE	27
CONTROLS	10	STARTING AFTER STORAGE	27
SAFETY INTERLOCK SYSTEM	11	TROUBLESHOOTING AND REPAIR	28
PUSHING THE TRACTOR BY HAND	12	BATTERY REPLACEMENT	32
BEFORE OPERATING	12	JUMP STARTING	32
STARTING THE ENGINE	12	TRACTOR BELT REPLACEMENT	35
STARTING AND STOPPING OPERATION	13	MOWER BELT REPLACEMENT	36
CLUTCH/BRAKE PEDAL OPERATION	14	ADJUSTMENTS	38
MOWING PATTERN AND TIPS	15	TRACTOR BRAKE	38
NORMAL CARE	16	ENGINE PULLEY BELT STOPS	39
NORMAL CARE SCHEDULE	16	NEUTRAL ADJUSTMENT	39
CHECKING/ADDING GASOLINE	17	MOWER ADJUSTMENTS	40
RAISING HOOD & SEAT DECK	17	SMALL LIFT LEVER	45
LUBRICATING THE TRACTOR	18	LARGE LIFT LEVER	46
LUBRICATING THE MOWER	19	SPECIFICATIONS	47
CHECKING TIRE PRESSURE	21	REPLACEMENT PARTS	48
CHECKING THE FUEL FILTER	21	OPTIONAL ATTACHMENTS & ACCESSORIES	49
SERVICING THE BATTERY	22	PARTS MANUAL AVAILABLE	51
ADJUSTING THE SEAT	22		

NOTE

In this manual "left" and "right" are referred to as seen from the operating position.

Safety Rules



Read these safety rules and follow them closely. Failure to obey these rules could result in loss of control of vehicle, severe personal injury to yourself or bystanders, or damage to property or equipment. The triangle  in the text signifies important cautions or warnings which must be followed.

GENERAL

- Read the Operator's Manual carefully. Be thoroughly familiar with the controls and the proper use of the equipment.
- Never allow children to operate the machine. Do not allow adults to operate it without proper instruction.
- Do not carry passengers.
- Use only attachments or accessories designed for your machine. See your dealer for a complete list of recommended attachments or accessories.
- Keep the area of operation clear of all persons, particularly small children, and pets.
- Never direct discharge of material toward bystanders.
- Make sure:
 - a. tractor and attachments are in good operating condition,
 - b. all safety devices and shields are in place and in good working condition, and
 - c. all adjustments are correct.

PREPARATION

- Handle gasoline with care - it is highly flammable.
 - a. Use approved gasoline container.
 - b. Never remove the fuel tank cap or add gasoline to a running or hot engine, or fill the fuel tank indoors. Wipe up spilled gasoline.
- Do not run the engine indoors. Exhaust fumes are deadly.
- Clear the work area of objects which might be picked up and thrown by attachments.
- Disengage all attachment clutches and move transmission control lever into neutral before attempting to start the engine.
- Wear heavy footwear. Do not operate tractor when barefoot or when wearing open sandals or canvas shoes.

OPERATION

- Engage the parking brake, disengage the PTO, lower the attachment, stop the engine and remove the key before leaving the operator's position for any reason, such as to unclog attachment chutes or to make repairs or adjustments.

Safety Rules

- Stop tractor and attachments and inspect for damage after striking a foreign object. Repair any damage before restarting and operating the equipment.
- Watch out for traffic when crossing or operating near roadways.
- Operate only in daylight or in good artificial light.
- Never make adjustment while the engine is running.
- After operation, place transmission control lever in forward position to help prevent accidental starting.
- Operate only up and down the face of slopes; never across the face. Do not stop or start suddenly on slopes.
- Reduce speed on slopes and in sharp turns to prevent tipping or loss of control. Use extreme caution when changing direction on slopes.
- Be especially careful not to touch tractor or attachment parts which might be hot from operation. Allow such parts to cool before attempting to maintain, adjust, or service.
- Stay alert for holes in the terrain and other hidden hazards. Be extra careful when operating on wet, slippery surfaces.
- If equipment begins to vibrate abnormally, disengage power to attachments and stop engine at once. Inspect for damage and correct before starting up tractor.
- Use care when pulling loads or using heavy equipment.
 - a. Use only drawbar hitch point.
 - b. Limit loads to those you can safely control.

- c. Do not turn sharply. Use care when backing.
 - d. Use weights when recommended in the tractor or attachment Operator's Manual.
- Disengage power to attachment(s) when transporting or not in use.



WARNING

Never place hands near the hydro pump cooling fan when the tractor is running. Cooling fan is located on left-hand side of hydro pump inside the rear frame.

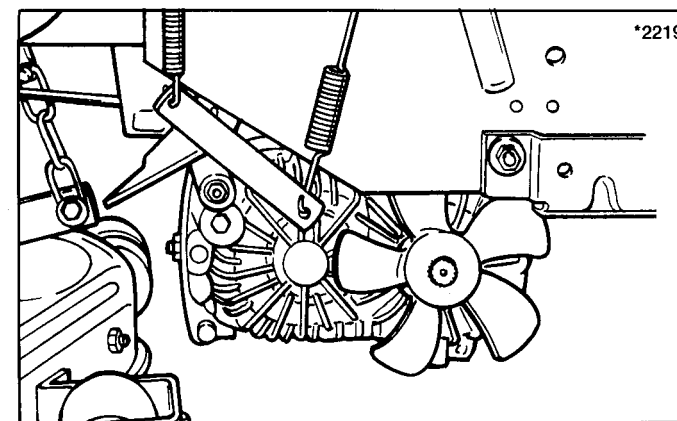

Cooling Fan Location (Shown with left-hand rear tire removed.)

MAINTENANCE & STORAGE

- **Keep all nuts, bolts, and screws tight to be sure the equipment is in safe working condition.**
- **Do not change the engine governor settings or overspeed the engine.**
- **To reduce fire hazard, keep the engine free of grass, leaves, and excess grease.**
- **Never store the equipment with gasoline in the tank inside a building where fumes may reach an open flame or spark. Allow the engine to cool before storing in any enclosure.**

Decals

ALL WARNINGS, CAUTIONS, and instructional messages on your tractor and mower should be carefully read and obeyed. Personal bodily injury can result when these instructions are not followed. The information is for your safety and it is important. The safety messages on this page are on your tractor and mower.

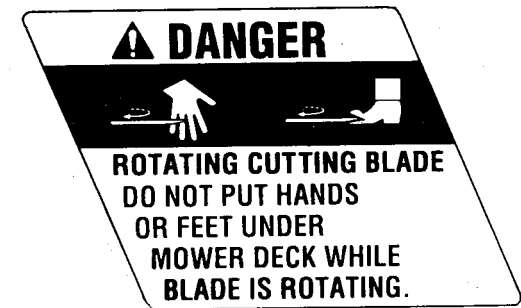
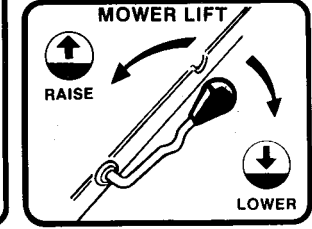
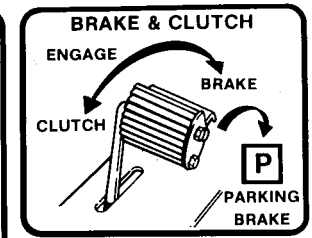
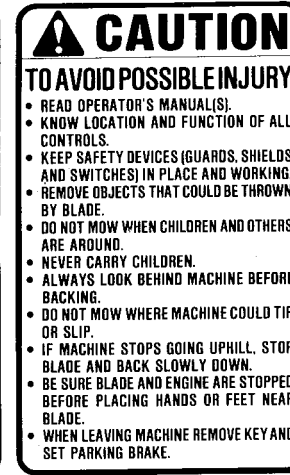
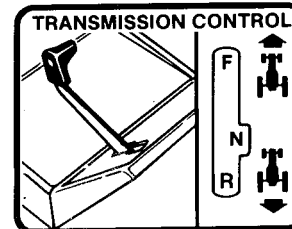
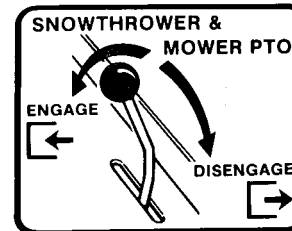
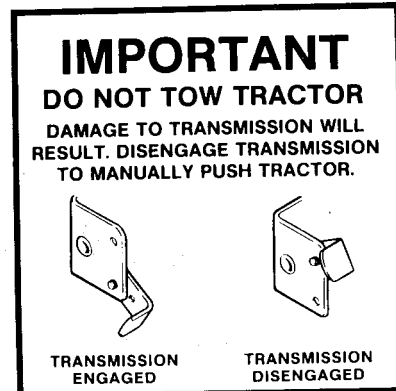

Mower Installation & Removal



WARNING

Engage the parking brake, disengage the PTO, stop the engine and remove the key before attempting to install or remove the mower.

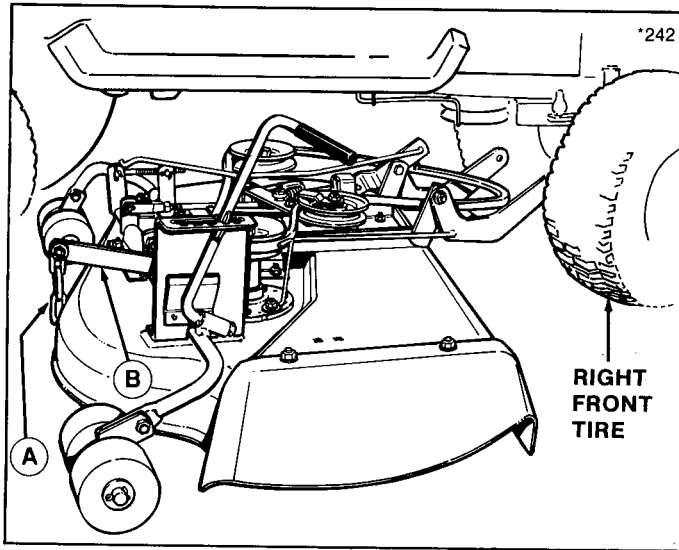

Figure 1. Installing 36" Mower

- A. Lift Chain
- B. Lift Arm
- C. Mower Hitch Arms

NOTE

The lift chain (A, figure 1) should be connected to the rear hole in lift arm (B) unless optional large lift arm (B, figure 8) is used to raise mower. With large lift lever, connect chain in forward hole.

1. Place your tractor on a level surface, with the mower on the right side of the tractor.
2. Turn the tractor front wheels full left (figure 1).
3. Place the mower in lowest cutting position and slide it under the tractor, aligning arms (C, figure 1) with tractor hitch (A, figure 2).

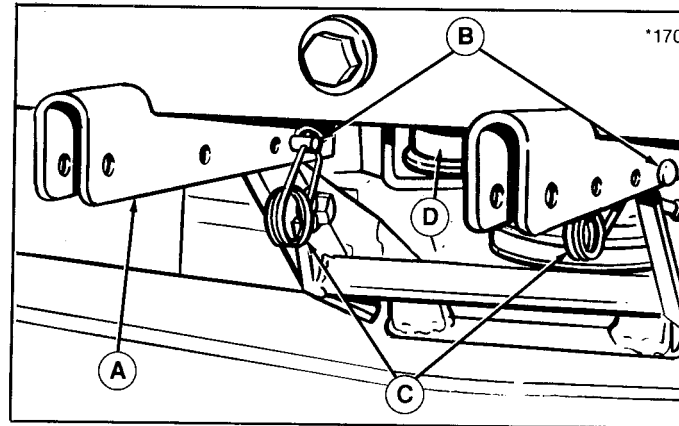

Figure 2. Mower Hitch Arms

- A. Hitch
- B. Pins
- C. Safety Clips
- D. Drive Belt

Mower Installation & Removal

4. Insert the link (A, figure 3) into lift arm (B) then pivot back and down. Secure chain (C) to clevis (D) with pin (E) and clip (F). If chain has four links, be sure to use only three links.

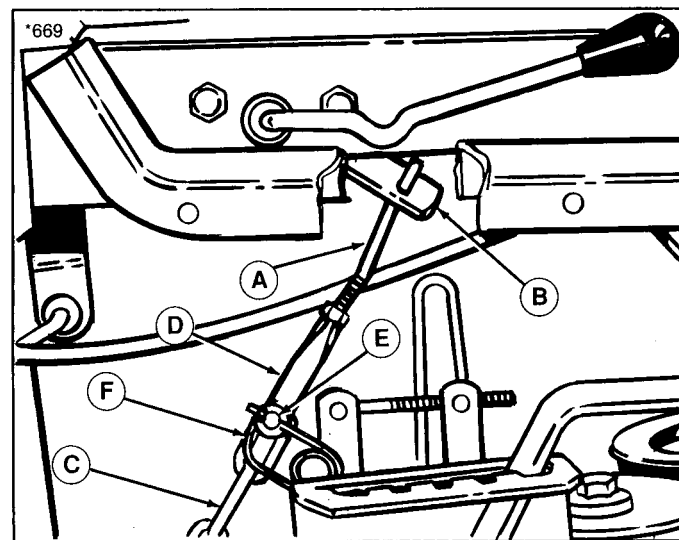

Figure 3. Lift Assembly
A. Lift Link D. Clevis
B. Lift Arm E. Pin
C. Chain F. Clip

5. Lift up front of mower and insert pins (B, figure 2) to attach mower hitch arms to tractor hitch (A). (You can insert a pry bar or wood under front edge to raise deck.) Connect the clips (C) into the pins.
6. Slip the mower drive belt onto the PTO pulley (C, figure 4). Loosen belt stops as necessary. The left-hand belt stop (A) is shown in figure 4. The right-hand belt stop is shown in figure 5. Make sure that the belt is routed between belt stop fingers. Check routing of belt by referring to figure 6.

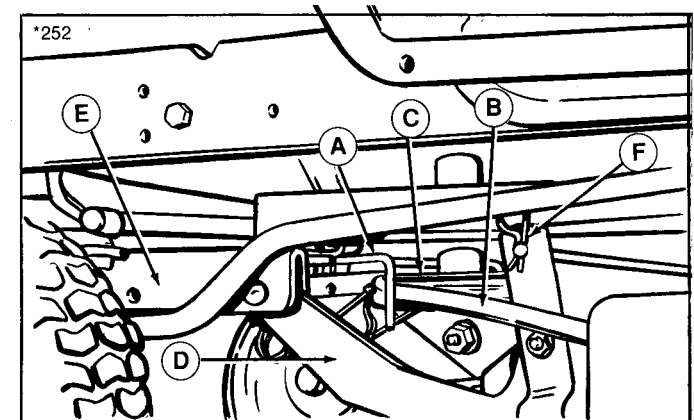

Figure 4. Left-Hand Belt Stop
A. Belt Stop D. Mower Hitch Arm
B. Belt E. Tractor Hitch
C. PTO Pulley F. Spring Clip

Mower Installation & Removal

7. Insert one end of the PTO rod (B, figure 7) in the mower PTO arm (A) and the other end in the tractor PTO arm (C) in hole marked "MOW". The rod must be inserted into the holes from the right-hand side as shown. Refer to figure 7 to make sure the rod is correctly positioned. Install the spring clips (D).
8. If installing mower for the first time, or if a new belt was installed, perform the mower adjustments in the Adjustments section.
9. Reverse the procedure to remove the mower.

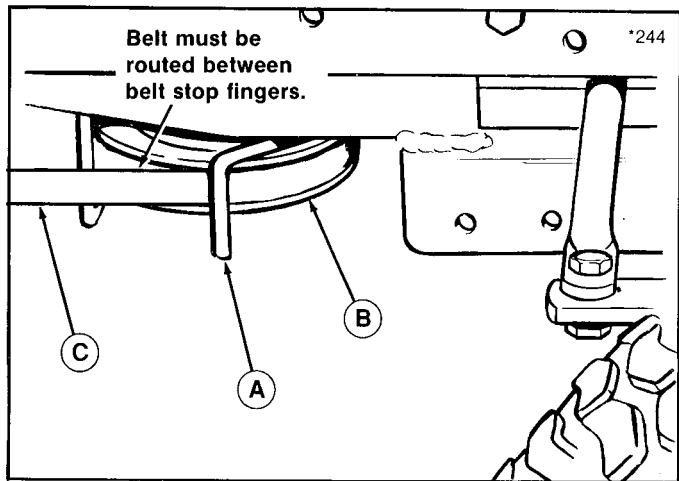

Figure 5. Right-Hand Belt Stop
A. Belt Stop B. PTO Pulley C. Belt

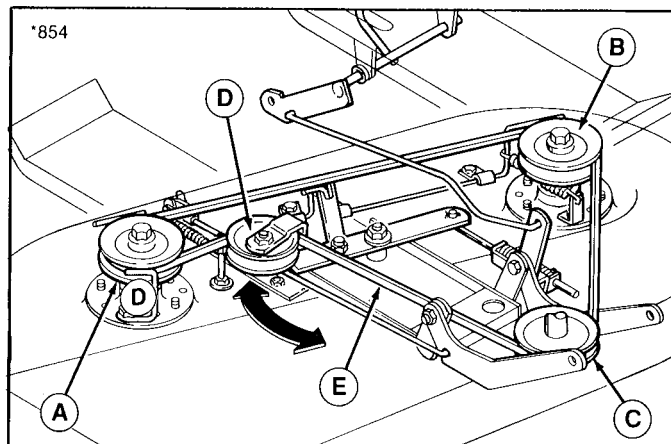

Figure 6. Mower Belt Pattern - 36"

- A. V-Pulley, Right Arbor
- B. V-Pulley, Left Arbor
- C. Engine PTO Pulley
- D. Flat Idler Pulley
- E. Belt

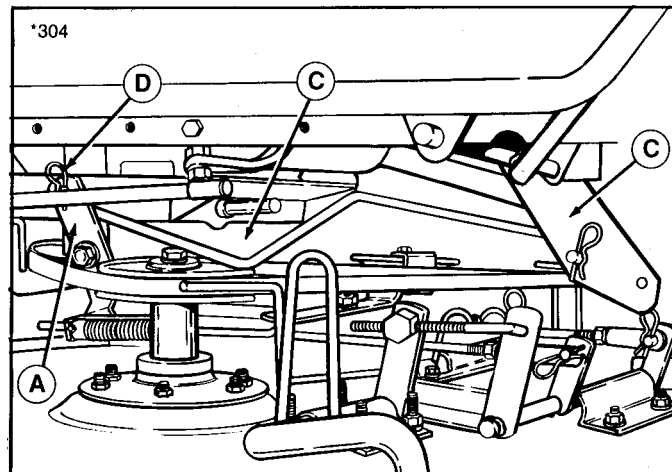

Figure 7. Installing PTO Rod

- A. Mower PTO Arm
- B. PTO Rod
- C. Tractor PTO Arm
- D. Spring Clip

Operation

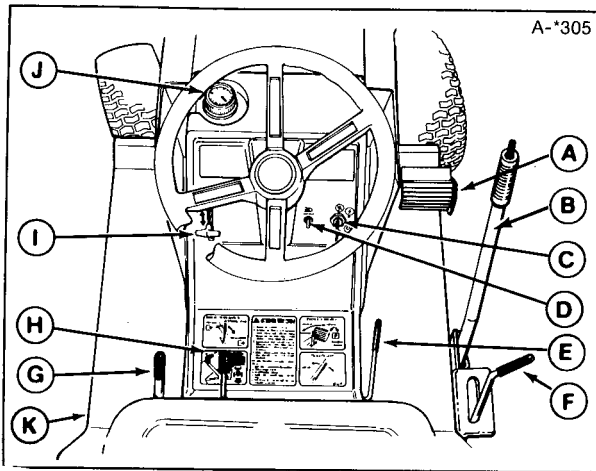

Figure 8. Tractor & Mower Controls

Ref.	Name	Function
A	Clutch-Brake	Disengages tractor clutch when pressed down at least halfway. Applies brake when fully depressed. Engages parking brake when latched over footrest.
B	Optional Lift Lever	Lifts and holds attachments in transport position (only required with attachment other than mower).
C	Ignition Switch	Operates with key to start, run, or stop engine.
D	Light Switch	Switches headlights on or off (if equipped).
E	Mower Lift Lever	Lifts and holds mower in transport position.
F	Mower Height Control Lever	Adjusts mower cutting height.
G	PTO (Power Take Off) Lever	Engages and disengages power to attachments. Pull back to disengage.
H	Transmission Control Lever	Controls ground speed and forward/reverse motion. Push toward left to move out of neutral (center) position. Push down to go forward. Pull up to go rearward.
I	Engine Speed Control	Position from SLOW to FAST to control engine speed. Also position for engine CHOKE.
J	Gas Gauge/Cap	Shows amount of gasoline in the tank and serves as tank cap.
K	Seat Deck Latch	Pull down on latch underneath left foot rest while raising seat deck.

SAFETY INTERLOCK SYSTEM

Your tractor is equipped with a seat switch safety system that will automatically shut the engine off when the operator leaves the seat with the PTO engaged or with the transmission lever in gear. The tractor engine will continue to run when the operator leaves the seat if the PTO is disengaged and the transmission is in neutral.

Check the seat switch (A, figure 9) every fall and spring with the following three tests. Make sure the wiring harness (B) is securely plugged into the switch.

WARNING

If the tractor does not pass the test, do not operate tractor. See your authorized dealer. Under no circumstance should you attempt to defeat the purpose of the safety system.

Test 1 — Engine should not crank if:

- A. Seat not occupied, or;
- B. Transmission lever in gear, or;
- C. PTO engaged.

Test 2 — Engine should crank if:

- A. Seat is occupied, and;
- B. Transmission lever in neutral, and;
- C. PTO disengaged.

Test 3 — Engine should shut off if:

- A. Operator rises off seat with transmission in gear, or;
- B. Operator rises off seat with PTO engaged.

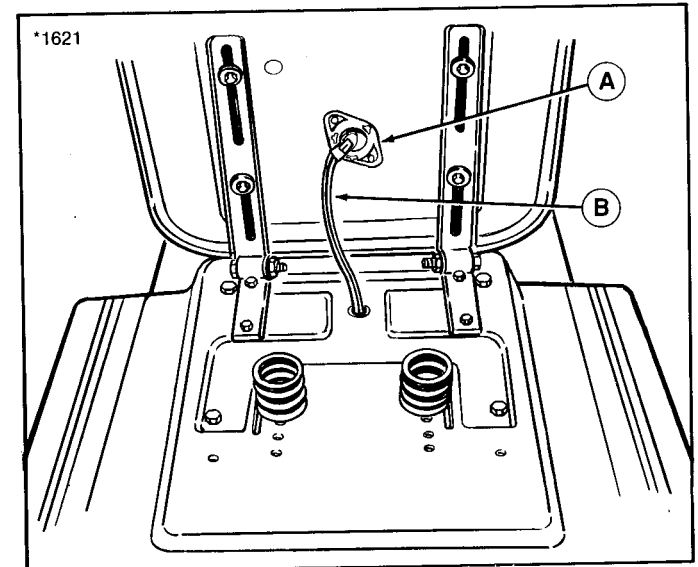

Figure 9. Seat Switch
A. Seat Switch
B. Wiring Harness



CAUTION

Do not tow tractor. Transmission damage may result.

PUSHING THE TRACTOR BY HAND

To push the tractor by hand, the hydro release lever (A, figure 10) must be in the "PUSH" position. Rotate the lever upwards and engage lever capscrew in wrapper hole. To drive tractor, rotate lever downward, making sure that bottom of lever is several inches away from plunger (B).

BEFORE OPERATING

1. Refer to Normal Care Chart and perform any needed care.
2. Clear the work area of any objects which may be caught in or thrown by the attachment.

STARTING THE ENGINE

1. Set the parking brake.
2. Place transmission control lever in NEUTRAL. The lever will snap into NEUTRAL notch when moved to center position.
3. Lift the PTO lever fully back to disengage the attachment.
4. Set engine speed control lever in CHOKE position. (A warm engine may not require choking.)

5. Insert the key into ignition switch and turn to START. Release when engine starts.
6. Move the throttle out of CHOKE position.

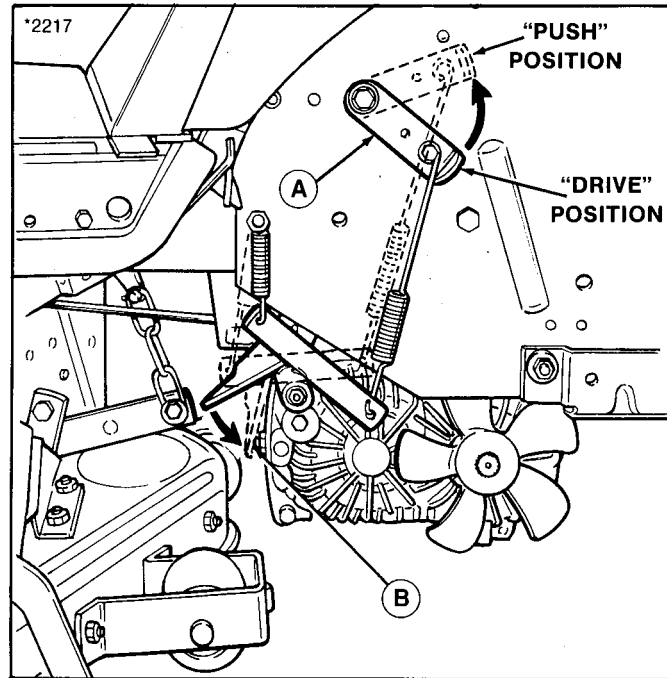

Figure 10.

A. Hydro Release Lever

B. Plunger



WARNING
Before leaving the operator's position for any reason, engage the parking brake, disengage the PTO, stop the engine and remove the key.

STARTING & STOPPING OPERATION

1. Start the engine as described in previous procedure.
2. Place the engine speed control lever between 3/4 and full speed. Full engine speed is recommended, especially if mowing thick grass or blowing heavy snow.
3. Release the parking brake by depressing pedal and unlatching from end of footrest.
4. If possible, the first motion should be straight forward or back. Position the front wheels straight ahead.
5. To go forward, move transmission control lever to left to move out of neutral, then press downward. The farther downward you press, the faster forward ground speed.
 To go rearward, move transmission control lever to left to move out of neutral, then pull up. The farther upward you pull lever, the faster rearward ground speed.
6. Use the ground speed control lever to select appropriate ground speed for conditions. If the terrain is rough, hilly or sloping, drive slowly. You should also drive slowly to cut thick grass or blow heavy snow. On level ground, with light grass or snow, you can use full speed.
7. Use the transmission control lever to slow down for turns or to trim around objects, then increase speed.

8. **To stop**, move the transmission control lever into NEUTRAL position. **For a more rapid stop**, depress the clutch-brake pedal. If you stop by depressing the pedal, move control lever to NEUTRAL before releasing pedal.
9. Before leaving the operator seat:
 - a. Stop tractor motion and engage parking brake.
 - b. Disengage the PTO and lower the attachment.
 - c. Set engine speed control to SLOW. Stopping a hot engine too fast may cause engine damage. Let engine idle for about a minute.
 - d. Turn key to OFF and remove it.



WARNING
Never operate on slopes greater than 30 percent (16.7°) which is a rise of three feet vertically in 10 feet horizontally. When operating on slopes that are greater than 15 percent (8.5°) but less than 30 percent use rear wheel weights (see your dealer). Select slow ground speed before driving onto slope. Mow UP and DOWN the slope, never across the face, use caution when changing directions and DO NOT START OR STOP.



WARNING
To reduce fire hazard, keep the engine, tractor and mower free of grass, leaves and excess grease.

CLUTCH/BRAKE PEDAL OPERATION

Refer to figure 11. Depressing pedal from position A to B disengages transmission drive. Depressing pedal further from position B to C will also apply tractor brake. Parking brake is applied at position C when pedal is latched over foot rest as shown in figure 11.

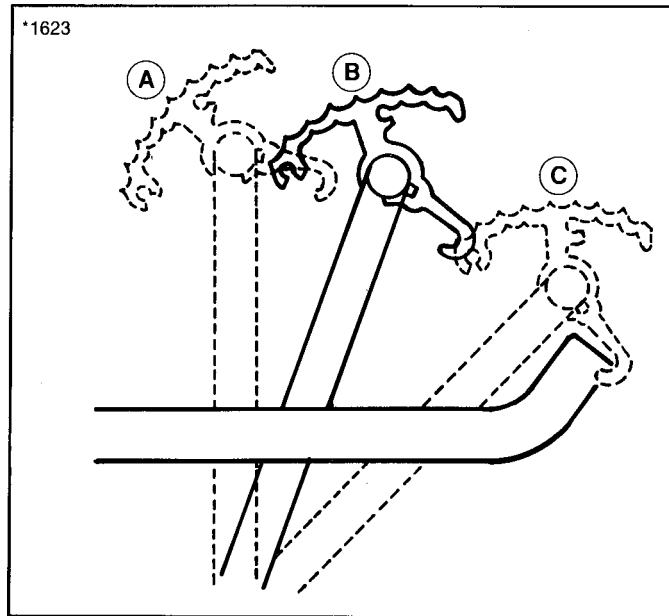

Figure 11. Brake/Clutch Pedal

MOWING PATTERN & TIPS

For the first use of the mower choose a smooth level area. Cut long straight strips overlapping slightly.

The size and type of area to be mowed determine the best mowing pattern to use. Obstructions such as trees, fences and buildings must also be considered. Where possible, make one or two passes in a clockwise direction around the outside of the area to keep cut grass off fences and walks. The remainder of the mower should be done in a counterclockwise direction so the clippings are dispersed on the cut area.

Where possible, keep the left side of the mower toward trees, posts, or other obstacles on the first pass around the obstacles to keep hand trimming to a minimum.

On moderate size, frequently mowed lawns where grass is light and dry, it is sometimes practical to mow in a clockwise direction so clippings are thrown toward the center of the lawn and concentrated for pickup and removal.

Most lawns should be mowed to keep the grass approximately two to three inches (50 to 76 mm) high. Best results are obtained by cutting often and not too short. To help keep a green lawn, never mow more than one third off the height of the grass, or a maximum of one inch (25 mm), in one mowing. For extremely tall grass, set the cutting height at maximum for the first pass, and then reset to the desired height and mow again.

On thick, or springy grass or soft ground, the mower rollers may sink into the ground giving too low a cut. Adjust the cutting height as necessary. For best appearance, grass should be cut in the afternoon or early evening (in daylight) where it is free of external moisture.

Where possible, change patterns occasionally to eliminate matting, graining or a corrugated appearance.

Normal Care

Safety Items	See	Before First Use	Before Each Use	Every 5 Hours	Every 25 Hours	Every 100 Hours	Spring & Fall
Check safety interlock system.	pg. 11	•					•
Check tractor brakes.	pg. 38	•					•
Check mower blade stopping time.	pg. 45	•	After adjustment or mower belt replacement.				•
Normal Care Items							
Check tractor & mower for loose nuts, screws, bolts, oil leaks, etc.		•	•	•			
Check engine oil level.	Eng.Mn.	•	•	•			
Check engine & air filter.	" "				**•		
Change engine oil and filter.*	" "				**•		***•
Lubricate tractor & mower.	pg. 18				**•		
Check fluid levels & tire pressure.	pg. 21	•	•		**•		
Check transmission fluid.	pg. 25	•		•			•
Check fuel filter.	pg. 21					•	
Clean battery & cables.	pg. 23					•	
Clean/sharpen blades.	pg. 27					•	
Inspect spark plug(s).	Eng.Mn.					•	
<p>*Change original engine oil after first 5 hours of operation. **More often in hot (over 85° F: 30° C) weather or dusty operating conditions. ***Only if tractor is used in both summer (over 40° F: 4.5° C). Use SAE 5W-30 engine oil for cold weather operation (under 30° F).</p>							

Normal Care Schedule

NORMAL CARE SCHEDULE

A schedule for normal care is provided in Table 1. If your tractor is not equipped with an optional hourmeter, you will need to keep a record of operating time.

CHECKING/ADDING GASOLINE

Check the gas gauge/cap to be sure there is enough gasoline to complete the job. To add gasoline, remove the gas gauge/cap. Refer to your engine manual for gasoline recommendations. Install and hand tighten the gas gauge/cap.

RAISING HOOD & SEAT DECK

To raise the hood, grasp both sides of the hood near the dash. Pull sides of hood outward and tilt the hood forward.

To raise the seat deck, position yourself as shown in figure 12. Pull down on the release located underneath the left-hand footrest and raise the seat deck.

Do not close the seat deck with the release lever pulled down.

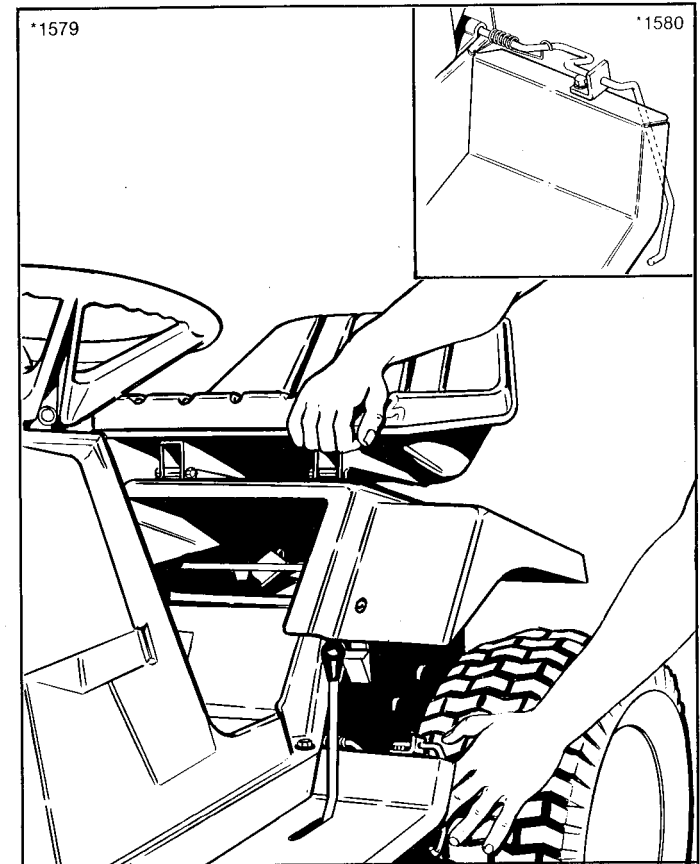

Figure 12. Opening the Seat Deck

LUBRICATING THE TRACTOR

Lubricate the tractor as shown in figures 13 thru 15. When a grease gun is shown, wipe the fitting clean, apply two or three shots of grease, and wipe off excess grease. Ask your dealer or refer to Common Replacement Parts section in this manual for recommended grease. When an oil can is shown, wipe the area clean, apply a few drops of oil (SAE 30), then wipe up drips or spills. Keep oil off belts, brake pads, and pulleys.

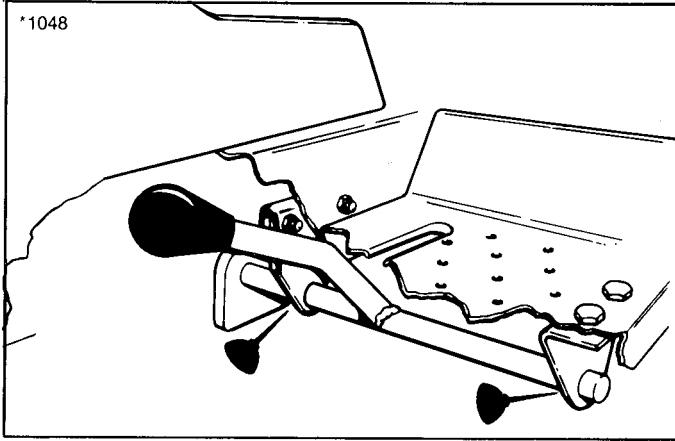

Figure 13. PTO Lever Lubrication

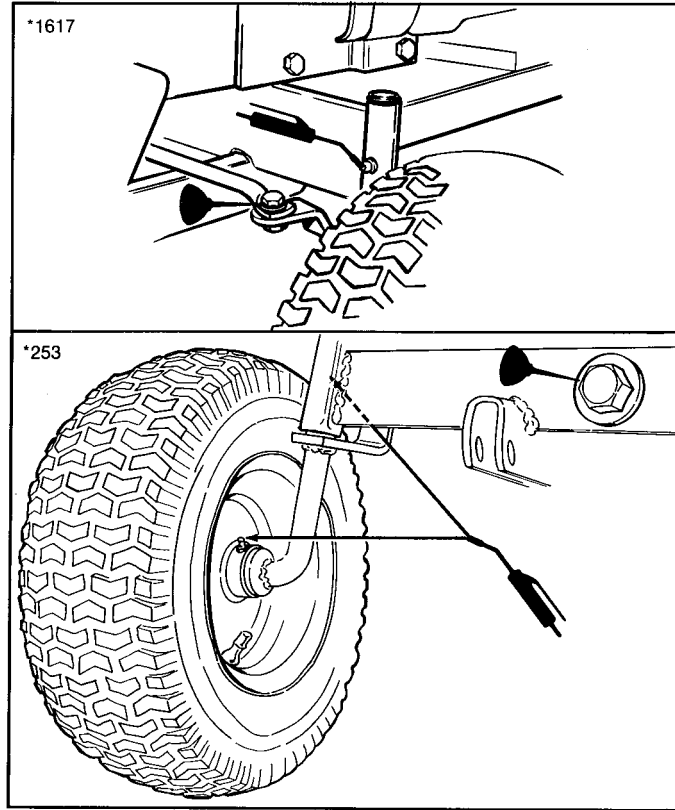

Figure 14. Front Axle Lubrication
(Two grease fittings on each side)

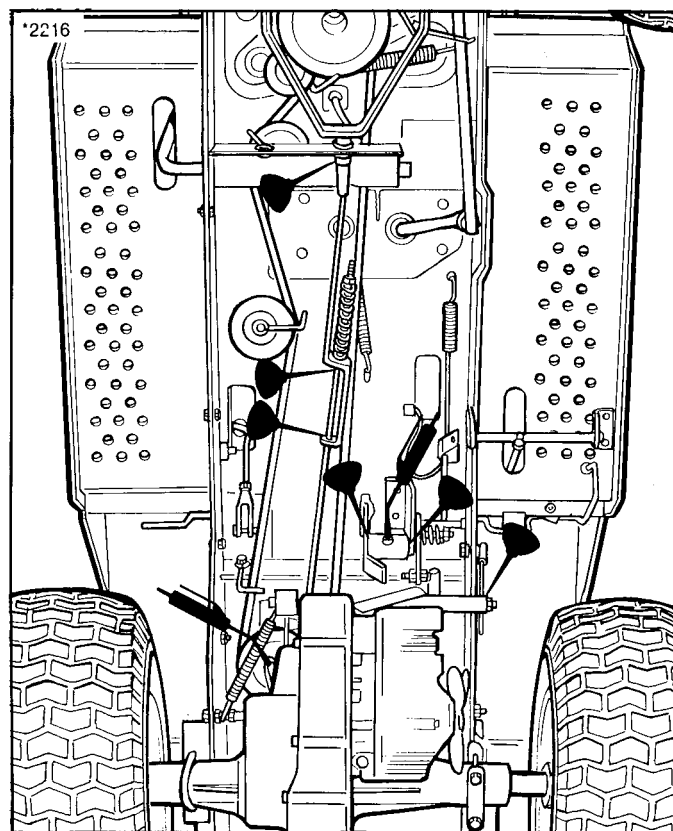

Figure 15. Clutch & Brake Rod Lubrication
(Underneath tractor)

LUBRICATING THE MOWER

Lubricate the mower as shown in figures 16 thru 18. Use an oil can with medium weight (SAE 30) oil. Brush and wipe dirt and grass from the area before applying oil. Wipe up drips and spills. Keep oil off belts and pulleys.

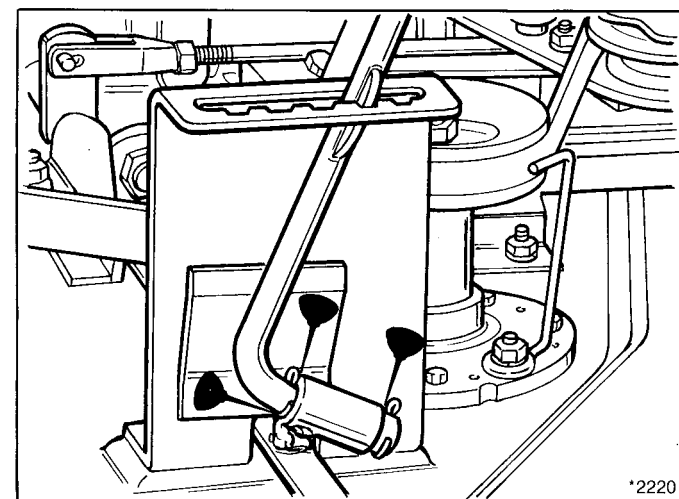

Figure 16. Lubricate Height Control Lever & Point
Where Roller Bar Contacts Bracket.

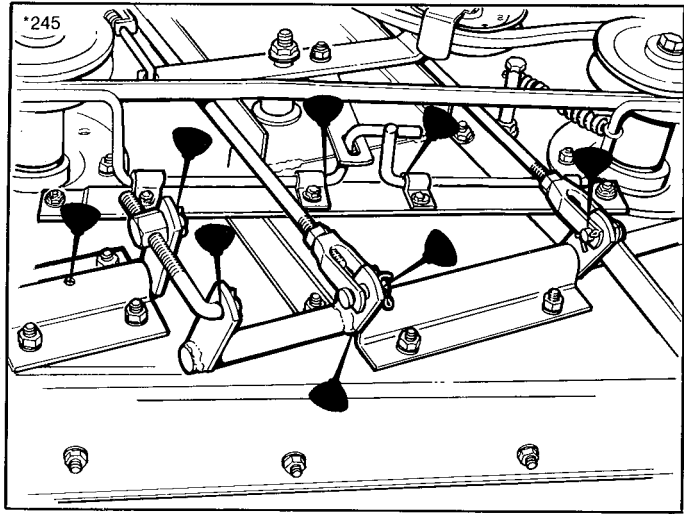

Figure 17. Lubricate Brake Lever, Clevises & Leveling Rod.

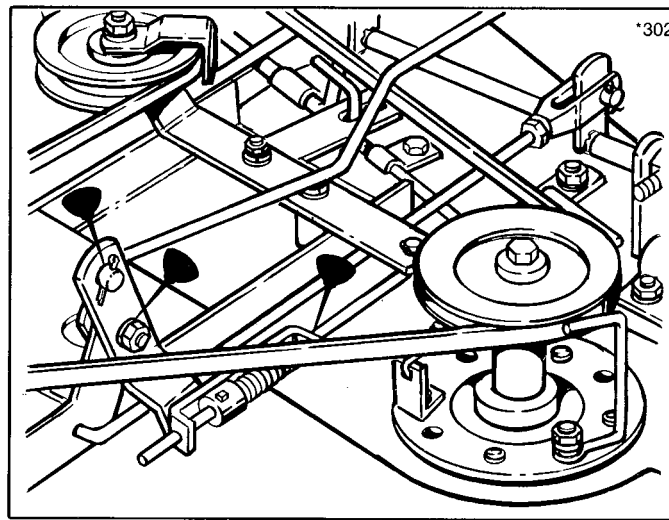

Figure 18. Lubricate Height, PTO Rod and PTO Arm.

CHECKING TIRE PRESSURE

Check air pressure of all four tires. Front tires should be 12 to 15 psi. Rear tires should be 6 to 8 psi. A gauge with one-pound markings will be necessary for an accurate check.

CHECKING THE FUEL FILTER

 **WARNING**

Do not remove fuel filter when engine is hot, as spilled gasoline may ignite. Do not spread hose clamps further than necessary. Insure clamps grip hoses firmly over filter after installation.

The fuel filter is located in fuel line between fuel tank and carburetor. If filter is dirty or clogged, replace as follows. Place a container below filter to catch spilled gasoline.

1. Using a pliers, open and slide hose clamps from fuel filter.
2. Remove hoses from filter.
3. Install new filter in proper flow direction in fuel line. Secure by reclamping with hose clamps. See warning at beginning of procedure.

SERVICING THE BATTERY

Checking Battery Fluid

1. Raise the seat.
2. Remove filler cap.
3. Fluid must be even with split ring full mark (figure 19). If not, add distilled water.
4. Reinstall filler cap.

 **WARNING**

Be careful when handling the battery. Avoid spilling electrolyte. Keep flames and sparks away from the battery.

 **WARNING**

When removing or installing battery cables, disconnect the negative cable FIRST and reconnect it LAST. If not done in this order, the positive terminal can be shorted to the frame by a tool.

Cleaning the Battery & Cables

1. Disconnect the cables from the battery, negative cable first (figure 19).
2. Remove the battery clamp, then remove the battery.

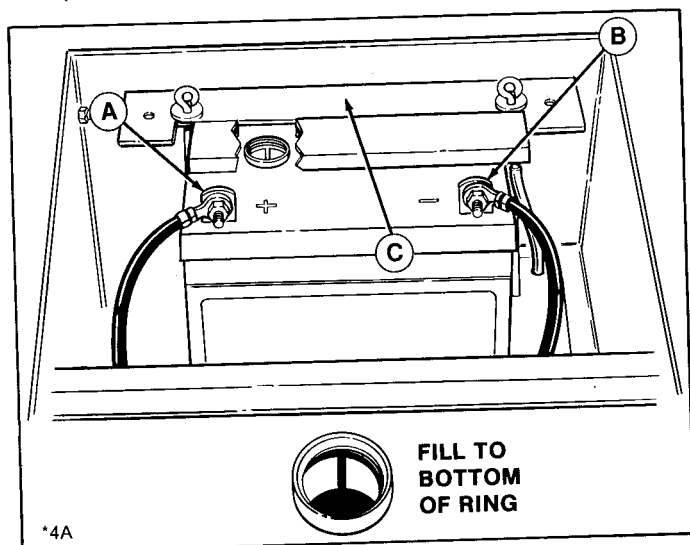

Figure 19. Battery
A. Positive Terminal
B. Negative Terminal
C. Battery Clamp

3. Scrub the battery, cables, and battery compartment with baking soda and water.
4. Clean the battery terminals and cable clamps with a wire brush.
5. Reinstall battery and clamp (figure 19).
6. Connect cables, positive cable first.
7. Coat cable clamps and terminals with grease or petroleum jelly.

ADJUSTING THE SEAT

Raise the seat deck. While holding the seat, loosen the four capscrews that secure seat to seat deck hinges. Position the seat as desired, then tighten the capscrews.

Seat springs can be adjusted for operator comfort. Move springs forward for lighter operator or toward the rear for heavier operator.

SHARPENING & BALANCING THE BLADES

1. Remove mower from tractor and position as in figure 20. Secure the mower so it will not fall.
2. Remove dirt and foreign matter.
3. Use wooden block to hold blade while removing capscrew (figure 20).
4. Sharpen the blade with a file. Remove nicks and dents in blade edge. If blade is damaged, it should be replaced.

WARNING

Blade mounting capscrews must be installed with the cup washer and spline washer (concave side up) and then securely tightened. Torque blade mounting capscrews to 50-70 ft. lbs. (68-76 N.m).

WARNING

Do not handle the mower blades with bare hands. Avoid touching the cutting edge. Careless or improper handling of blades may result in serious injury.

5. Check and balance blade. Use a balancing machine or the fixture shown in figure 21. Center the blade on a nail lubricated with a drop of oil. A balanced blade will remain level. File material off heavier end of blade until it is balanced.

6. Reinstall each blade with the tabs pointing up toward deck and secure with a capscrew, cup washer, and spline washer. Be sure all splines are aligned and washer is flush against blade. Make sure the cup washer is installed concave side up (toward mower deck). Use a wooden block as shown in figure 22 to prevent blade rotation and torque capscrew to 50-70 ft. lbs. (68-74 N.m).

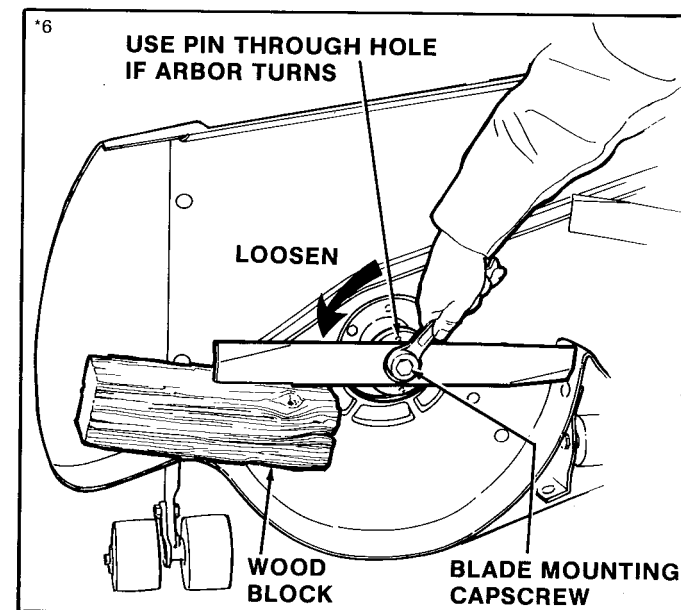

Figure 20. Removing Blade

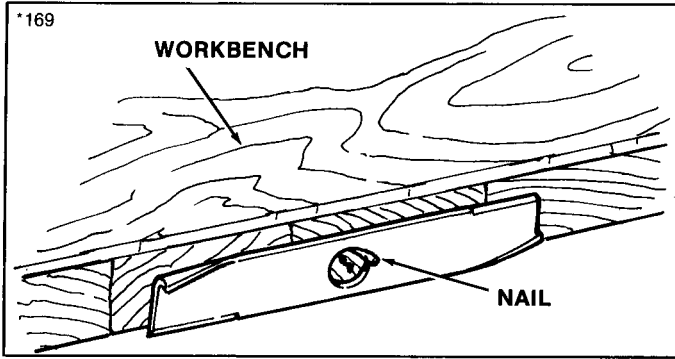

Figure 21. Balancing Blade

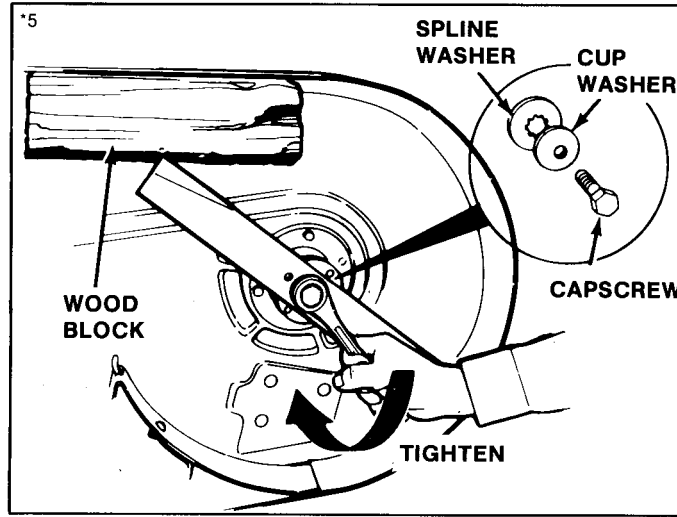

Figure 22. Installing Blade

CHECK TRANSMISSION FLUID LEVEL**Hydrostatic Fluid Level**

1. Allow tractor to cool after operation. Fluid must be cool for an accurate check.
2. The fluid level is visible in the reservoir (figure 23) without removing cap. The level should be between the two lines. If not, go to step 3.
3. Raise the seat deck.
4. Before removing reservoir cap, clear all grass and debris from battery compartment and area around the hydro reservoir.
5. Remove the reservoir cap. If diaphragm does not come out with cap, remove it. Add 30W premium grade nondetergent oil as required. If oil is black or milky, see your dealer to determine cause.
6. Check the level again after operating the tractor a few times. If level is consistently low, see your dealer to check for leaks.

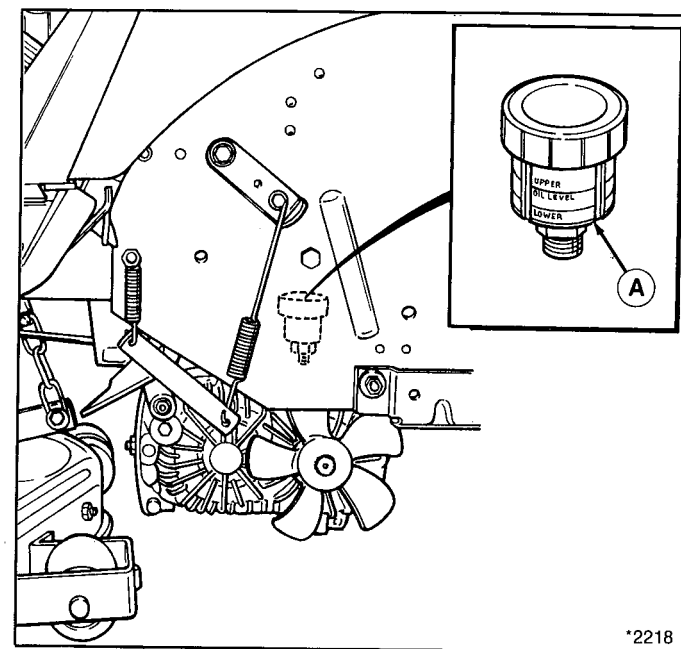

Figure 23. Hydrostatic Reservoir
A. Reservoir

*2218

Transaxle

The transaxle and hydro pump are a sealed unit. The transaxle is packed with grease and does not require any further lubrication unless a service overhaul is performed. Apply two shots of grease every 100 hours to fitting on input shaft of hydro pump.

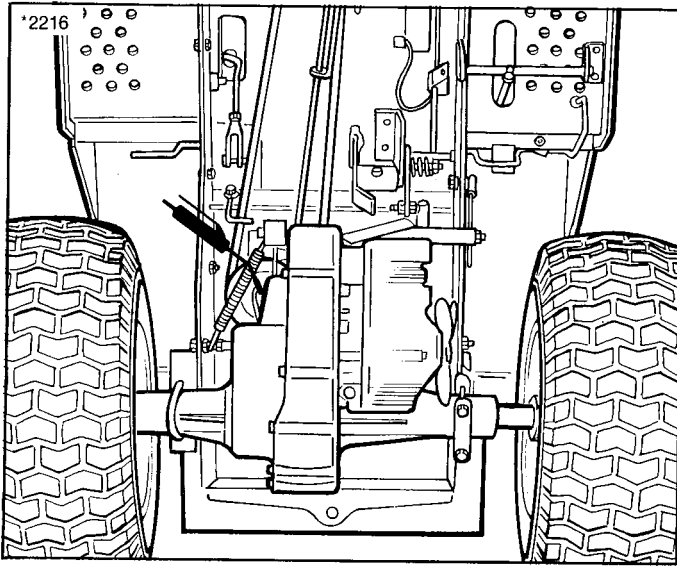

Figure 24. Grease Fitting

TRACTOR OFF-SEASON STORAGE

When the tractor is to be stored for two months or longer, take precautions as follows:

WARNING

Gasoline is highly flammable. Keep open flame or spark away from gasoline and fuel tank. Never store tractor where gasoline fumes may reach an open flame or spark.

1. To empty or prepare fuel tank:
 - a. Run tractor engine until it stops from lack of fuel, or;
 - b. Use a gasoline stabilizer. This additive, available from your dealer, prevents formation of gum and varnish for up to one year. With the additive, fuel may remain in your tank for long periods.
2. Change engine oil while the engine is still warm. Record the type and weight of oil put in crankcase.
3. Remove spark plug. Pour one ounce (30 ml) of SAE 30 oil into engine through spark plug hole. Crank engine a few times to distribute oil and then reinsert the spark plug.
4. Lubricate the tractor.
5. Check battery fluid level. Battery life will be extended if it is removed and stored in a cool, dry place. Battery should be fully charged for storage.
6. Clean tractor thoroughly. Coat all exposed bare metal parts with a good quality paint (obtainable from your dealer) or a light film of grease or oil.

MOWER OFF-SEASON STORAGE

To protect your mower, store it in an enclosed dry area. To prepare the mower for off-season storage, perform the following.

1. Remove mower from tractor if tractor is to be used without mower. (See Mower Installation and Removal section).
2. Clean top and underside of mower to remove all grass and dirt.
3. Coat all bare metal surfaces with a good quality paint (available from your dealer) or a light coat of oil to prevent rusting.
4. Lubricate mower.
5. Check, sharpen and balance the mower blades.
6. The belt should be stored in a cool, dark place away from sunlight or any heat source.

STARTING AFTER STORAGE

1. Replace battery, if removed. Be sure terminals and clamps are clean.
2. Remove the spark plug and wipe dry. Crank engine a few times to blow excess oil out of plug hole. Reinstall the plug.
3. Fill fuel tank with fresh gasoline (unless a fuel stabilizer was used).
4. Clean engine fins and air filter. (See engine manual).
5. Check fluid levels and tire pressure. (See Normal Care Chart.)
6. Start the engine outdoors. Do not run engine at high speeds immediately after starting.

Troubleshooting & Repair

CONTENT OF SECTION

This section of the manual provides troubleshooting and repair instructions for the more common and easily corrected problems. For other problems, it is recommended that you contact your dealer.

TROUBLESHOOTING PROCEDURES

Troubleshooting procedures are provided in Table 2. To use these procedures, first locate the problem description that best describes the trouble that you have encountered. Check the possible causes one at a time in the order that they are listed.



WARNING

To avoid serious injury, perform maintenance on the tractor or mower only when the engine is stopped and the parking brake engaged. Always remove the ignition key and disconnect spark plug wire and fasten away from the plug before beginning the maintenance to prevent accidental starting of the engine.

1. Engine will not start.

- A. Transmission control lever not in NEUTRAL. Move into NEUTRAL.
- B. PTO clutch lever not disengaged. Disengage fully.
- C. Operator not seated. Operator must be in seat to start engine.
- D. Out of fuel. Refill fuel tank.
- E. Engine flooded. Move control out of choke & attempt to start.
- F. Circuit breaker tripped. Wait one minute for automatic reset. Replace if defective (see your dealer).
- G. Battery terminals require cleaning. See Normal Care section.
- H. Battery discharged or dead. Recharge or replace.
- I. Wiring loose or broken. Visually check wiring & replace broken or frayed wires. Tighten loose connections.
- J. Solenoid or starter motor faulty. Repair or replace.
- K. Safety interlock switch faulty. Replace if needed. (See your dealer.)
- L. Spark plug faulty, fouled, or incorrectly gapped. Clean & gap or replace.
- M. Old stale gas. Drain fuel & replace with fresh fuel.

-
2. **Engine starts hard or runs poorly.**
- A. Fuel mixture too rich. Move control out of choke. If problem still exists, clean air filter.
 - B. Carburetor adjusted incorrectly. See your engine manual.
 - C. Spark plug faulty, fouled, or incorrectly gapped. Clean and gap or replace.
-
3. **Engine knocks.**
- A. Low oil level. Check/add oil as required.
 - B. Using wrong grade oil. See Normal Care section.
-
4. **Excessive oil consumption.**
- A. Engine running too hot. Clean engine fins, blower screen and air cleaner. See Normal Care section.
 - B. Using wrong weight of oil See Normal Care section.
 - C. Too much oil in crankcase. Drain excessive oil.
-
5. **Engine exhaust is black or smoky.**
- A. Dirty air filter. Clean air filter.
 - B. Choke not fully open. Move control out of choke and be sure choke opens fully. If problem still exists, check carburetor adjustment.
-
6. **Engine runs, but tractor will not drive or lacks power.**
- A. Check fluid levels (Transmission).
 - B. Drive belt slips. See problem and cause below.
 - C. Transmission control lever in NEUTRAL. Move into forward or reverse.
-
7. **Drive belt slips.**
- A. Pulleys or belt greasy or oily. Clean as required.
 - B. Belt stretched or worn. Replace with correct belt.
 - C. Clutch rod binding in guide. Oil clutch rod. See Tractor Lubrication.

8. Brake will not hold.

- A. Brake is incorrectly adjusted. See Adjustment section.
 - B. Brake pads worn & require replacement. See your dealer.
-

9. Tractor handles poorly.

- A. Steering linkage is loose. Check and tighten any loose connections.
 - B. Improper tire inflation. Check and correct.
 - C. Wheels are spinning and slipping. Use weights to provide additional stability and traction.
 - D. Moving too fast on slopes. Reduce speed.
-

10. Tractor drive belt does not stop when clutch-brake pedal is depressed.

- A. Belt stops out of adjustment. See Adjustments section.
 - B. Linkage not operating properly.
-

TROUBLESHOOTING (Mower)

1. Mower will not raise.

Lift chain not attached or broken. Attach or repair.

2. Uneven cut.

- A. Mower not leveled properly. See leveling adjustment in Mower Adjustment section.
 - B. Tractor tires not inflated equally or properly.
-

3. Mower cut is rough looking.

- A. Engine speed too slow. Set for three-fourths to full speed.
- B. Tractor ground speed too fast. Use lower gear.
- C. Blades dull & require sharpening. See Normal Care section.
- D. Mower drive belt slipping. Belt oily or worn. Clean or replace belt as necessary. Readjust belt tension.

-
- 4. Engine stalls easily with mower engaged.**
- A. Tractor ground speed too fast. Use lower gear.
 - B. Engine speed too slow. Set for three-fourths to full speed.
 - C. Cutting height set too low when mowing tall grass. Cut tall grass at maximum cutting height during first pass.
 - D. Discharge chute jamming with cut grass. Cut grass with discharge pointing toward previously cut area.
-
- 5. Excessive mower vibration.**
- A. Blade mounting screws are loose. Torque to 50-70 ft. lbs. (68-76 N.m). See Normal Care section.
 - B. Mower blades, arbors, or pulleys are bent. Check and replace as necessary.
 - C. Mower blades are out of balance. Remove, sharpen, and balance blades (see Normal Care section).
-
- 6. Excessive belt breakage.**
- A. Belt tension too tight. Readjust belt tension.
 - B. Bent or rough pulleys. Repair or replace.
 - C. Using incorrect belt. See your dealer.
-
- 7. Mower drive belt slips or fails to drive.**
- A. Mower drive belt out of adjustment. See Adjustment section.
 - B. Mower drive belt broken. Replace belt.

BATTERY REPLACEMENT

A dead battery or one too weak to start the engine may not mean the battery needs to be replaced. It may, as an example, mean that the charging system is not working properly or that the battery has lost its charge during storage. First, "Clean Battery & Cables" and "Check Battery Fluid Level". Have the battery recharged if necessary. If there is any doubt about the cause of the problem, see your dealer. If you must replace the battery, remove and install the battery as described in "Clean Battery & Cables".

JUMP STARTING WITH AUXILIARY (BOOSTER) BATTERY

Jump starting is not recommended. First, check the battery as described in "Battery Replacement" above. If jump starting must be done, follow these instructions and refer to figure 25. Both booster and discharged batteries should be treated carefully when using jumper cables. Follow exactly procedures one through five, being careful not to cause sparks.



WARNING

For your personal safety use extreme care when jump starting. Never expose battery to open flame or electric spark - battery action generates hydrogen gas which is flammable and explosive. Do not allow battery acid to contact skin, eyes, fabrics, or painted surfaces. Batteries contain a sulfuric acid solution which can cause serious personal injury or property damage.

1. Both batteries should be of the same voltage (12V).
2. Position the vehicle with the booster battery adjacent to the vehicle with the discharged battery so that booster cables can be connected easily to the batteries in both vehicles. **Make certain vehicles do not touch each other.**
3. Set parking brake and place transmission in "NEUTRAL". Turn off lights and other electrical loads.
4. Remove vent cap from both the booster and the discharged batteries. Lay a cloth over the open vent wells on each battery. These two actions help reduce the explosion hazard always present in either battery when connecting a "live" battery to a "dead" battery.
5. Attach one end of one jumper cable to the positive terminal of the booster battery (identified by a red color, "+" or "P" on the battery case, post or clamp) and the other end of same cable to positive terminal of discharged battery. **DO NOT** permit vehicles to touch each other, as this could establish a ground connection.

6. Attach one end of the remaining cable to the negative terminal (black color, "-" or "N") of the booster battery, and the other end to a bare metal surface on the frame of your tractor AWAY FROM the battery compartment (do not connect directly to negative post of dead battery). Take care that clamps from one cable do not inadvertently touch the clamps on the other cable. Do not lean over the battery when making this connection.
7. The tractor with the discharged battery should now start.

Reverse the jump starting procedure exactly to remove the jumper cables. Then reinstall the vent caps and throw the cloths away as they may have corrosive acid on them.



WARNING

Any procedure other than the above could result in: (1) personal injury caused by electrolyte squirting out of the battery vents, (2) personal injury or property damage due to battery explosion, (3) damage to the charging system of the booster vehicle or the immobilized vehicle.

Do not attempt to jump start a vehicle having a frozen battery because the battery may rupture or explode. If a frozen battery is suspected, examine all fill vents of the battery. If ice can be seen or if the electrolyte fluid cannot be seen, do not attempt to start with jumper cables as long as the battery remains frozen.

THIS HOOK-UP FOR NEGATIVE GROUND VEHICLES

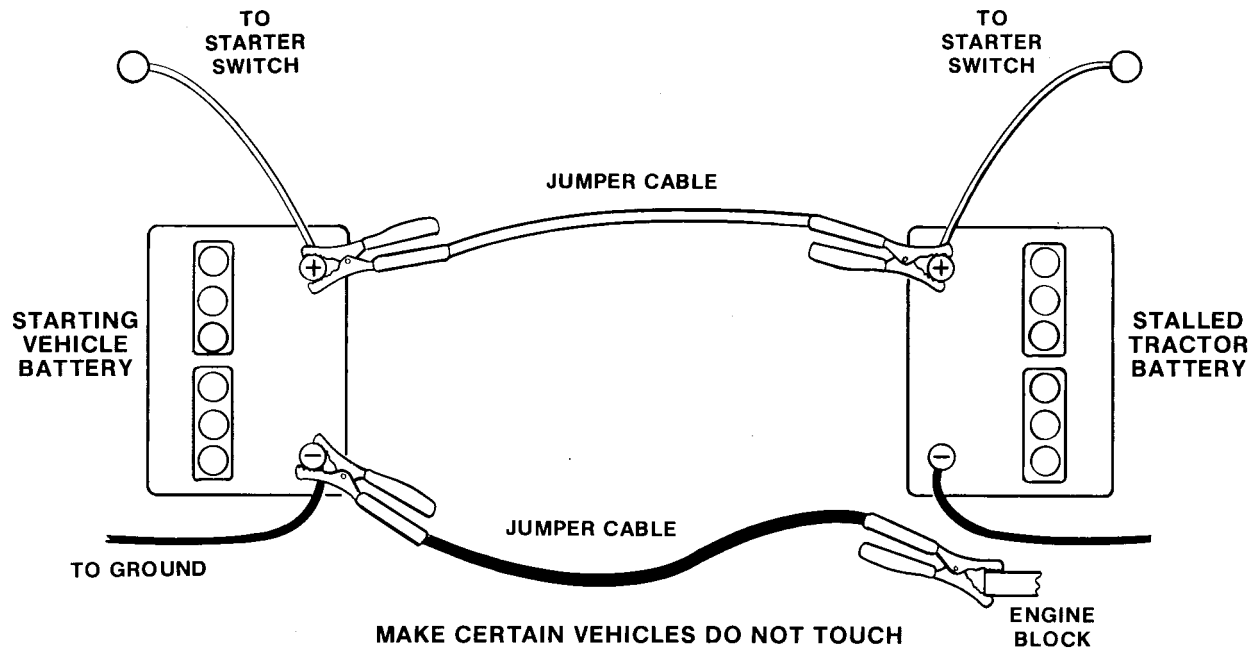

Figure 25.

TRACTOR DRIVE BELT REPLACEMENT

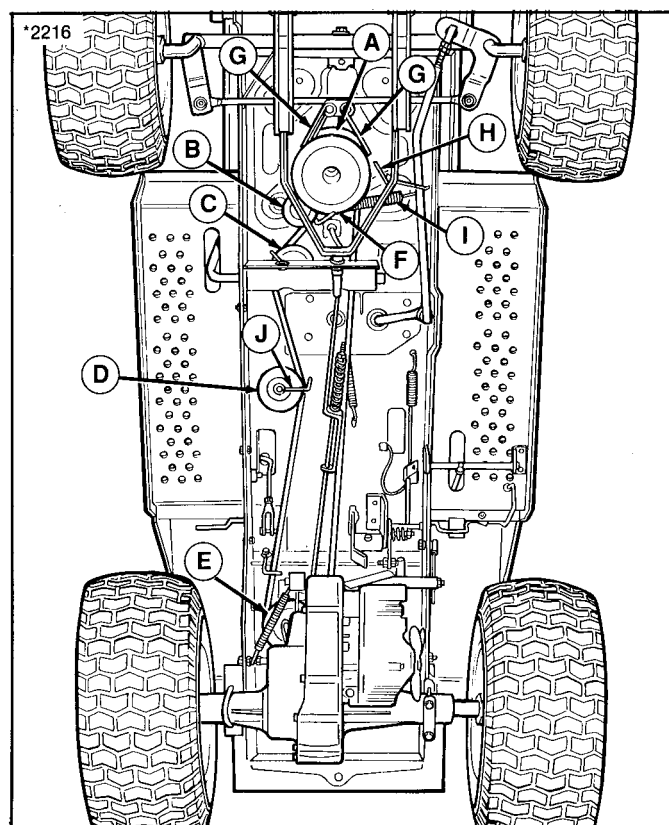

Figure 26. Tractor seen from underneath



CAUTION

To avoid damaging belt, do not pry over pulleys.

1. Remove the mower from the tractor.
2. With the clutch disengaged, remove the idler pulley spring (I).
3. Loosen the PTO pulley belt stops (G, figure 26).
4. Remove the tractor belt from the engine pulley (A) and allow to rest on top of the PTO pulley.
5. Loosen the belt stop on the idler pulley (B) and remove the belt.
6. Loosen the capscrew securing belt stop (J) and remove belt from idler pulley (D).
7. Loosen the belt stop (F, figure 27) and remove the belt from the transmission pulley (E).
8. Remove the belt from PTO pulley (F) and tractor.

A. Engine Pulley
 B. Pulley, Flat
 C. Idler Pulley
 D. Idler Pulley, Flat
 E. Transmission Pulley

F. PTO Pulley
 G. PTO Pulley Belt Stops
 H. Belt Stops, Engine Pulley
 I. Idler Pulley Spring
 J. Idler Pulley Belt Stop

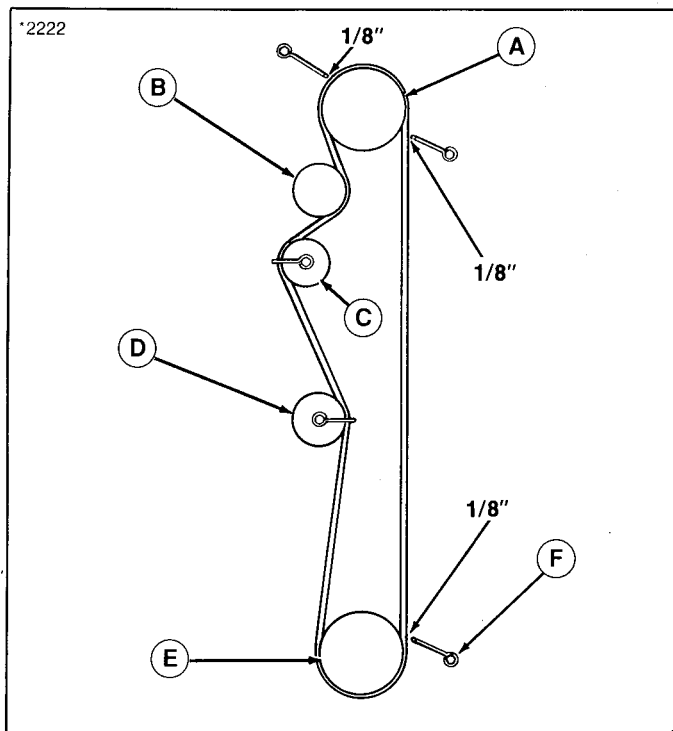

Figure 27. Belt Diagram

- A. Engine Pulley
- B. Idler Pulley
- C. Idler Pulley

- D. Idler Pulley, Middle
- E. Transmission Pulley
- F. Belt Stop

9. Install the new belt by reversing the procedure. Be sure the V side of the belt is against all the pulleys except the flat idler pulleys (B and D, figure 26 and 27). The belt diagram is shown in figure 27.
10. Reinstall belt over idler pulley belt stop (J) and tighten capscrew. Make sure pulley can rotate freely after installation.
11. Reinstall idler pulley spring.
12. Perform "Tractor Brake Adjustment" and all belt stop adjustments. Make sure belt stop (F, figure 27) is positioned 1/8" from transmission pulley (in the forward position).

NOTE

Reference letters in Figure 26 are same as reference letters A thru E in Figure 27.

MOWER BELT REPLACEMENT



CAUTION

To avoid damaging belt do not pry belt off pulleys.

1. Remove mower from the tractor.
2. Loosen the belt guide (C, figure 28) on the idler pulley.
3. Move idler arm (B) toward rear of mower deck to release blade brakes.
4. While holding brake released, remove belt from right and left arbor pulleys.
5. Install the new belt on the pulleys as shown in figure 29.

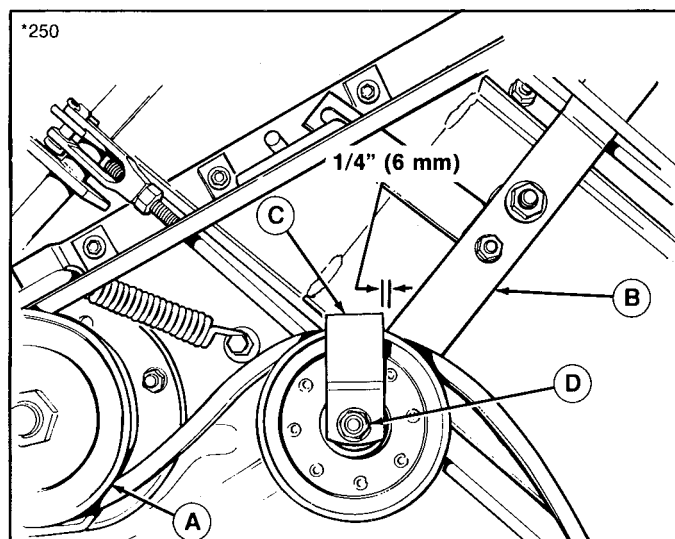

Figure 28. Mower Belt Replacement

- A. Arbor Pulley**
- B. Idler Arm**
- C. Belt Guide**
- D. Nut**

6. Reinstall the mower on the tractor (see Mower Installation). Check mower drive belt tension as outlined in the Adjustment section. Run the mower under no load conditions for about 5 minutes. Recheck belt tension and blade brake adjustment after 1 hour of operation.

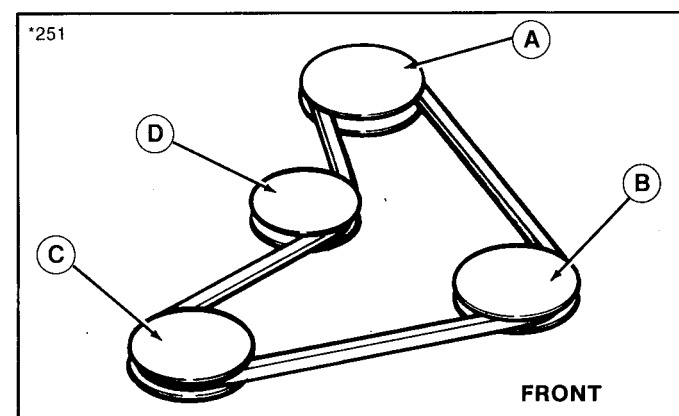

Figure 29. Mower Belt Pattern

- A. V-Pulley, Right Arbor**
- B. V-Pulley, Left Arbor**
- C. Engine PTO Pulley**
- D. Flat Idler Pulley**

7. Reposition the belt guide on the idler pulley (figure 28). Before tightening the nut (D), position the belt guide so it is 1/4 inch (6 mm) behind the idler arm (B) when viewed from above (figure 28). Hold the belt guide when tightening nut.

NOTE

Each time after changing the mower belt tension, perform the remaining mower adjustments: Right-Arbor Belt Stop, Idler Pulley Belt Guide, PTO Pulley Belt Stops, and Blade Brake.

Adjustments

WARNING

To avoid serious injury, perform adjustment only with engine stopped, key removed, and tractor on level ground.

WARNING

Disconnect the battery cables, negative cable first before performing adjustments. If this is not done, the electrical circuit can easily be shorted to the frame by a tool, which could cause sparks or electrical shock.

TRACTOR BRAKE ADJUSTMENT

1. With clutch/brake pedal released, rotate the brake cam (A, figure 30) forward until it stops. There should be 3/16" gap between transaxle housing (B) and rear point of brake cam.
2. If adjustment is required, remove cotter pin and turn adjusting nut (C) until proper 3/16" clearance is achieved. Turning the nut in will decrease clearance and turning the nut out will increase clearance. Reinstall cotter pin after adjustment.
3. Depress the clutch/brake pedal and latch parking brake over footrest. When compressed, the brake spring (A, figure 31) should be 3-3/8", measured between the rod guide (B) and adjusting nut (C).

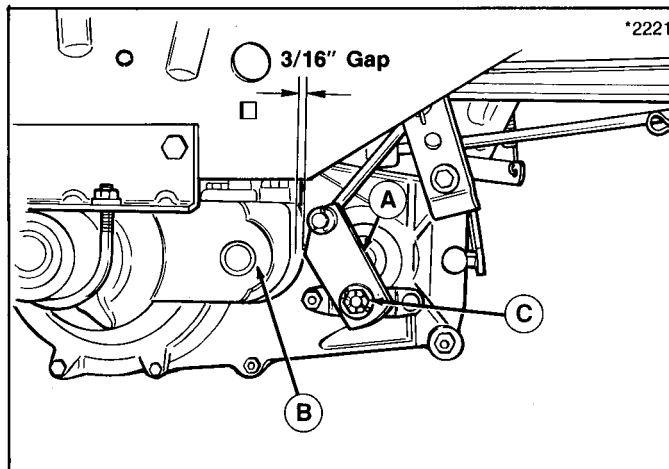

Figure 30. Brake Adjustment

- A. Brake Cam
- B. Transaxle Housing
- C. Adjusting Nut

4. If adjustment is required, turn adjusting nut (C) until proper 3-3/8" spring length is achieved.

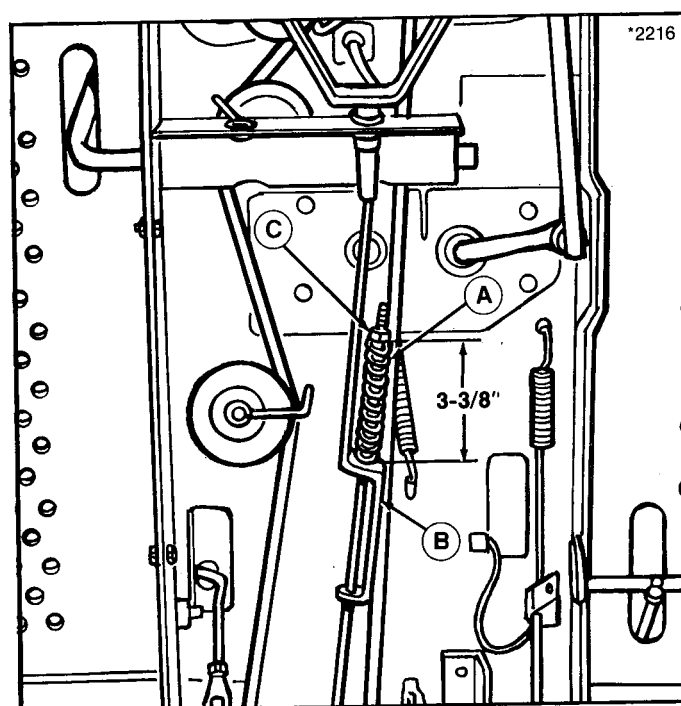

Figure 31. Brake Spring Adjustment

- A. Brake Spring**
- B. Rod Guide**
- C. Adjusting Nut**

ENGINE PULLEY BELT STOPS

Adjust the two belt stops (A, figure 25) so there is 1/8" between belt stops and belt.

NEUTRAL ADJUSTMENT

If the tractor creeps forward or back with transmission in neutral notch, adjust as follows.

1. Seat yourself in the operator's seat and start the engine.
2. Move the lever to position where tractor remains stationary. This is neutral position.
3. Stop the engine.
4. Disconnect the battery cables to avoid causing short circuit or sparks with tools.
5. Raise the seat deck. The control lever quadrant (A, figure 32) is mounted with slotted holes so it can be adjusted. Loosen the two self-tapping screws (C) and move the quadrant so the lever is centered in the quadrant gate. Then tighten the two screws.
6. Connect the battery cables.
7. Lower the seat deck. Start the engine to check again. If the tractor still creeps in neutral, proceed to step 8.
8. Return the quadrant to the center position, if moved. Loosen the front nut (A, figure 33) and rear nut (B) on the hydro shift rod (C). The rear nut is a left-hand thread.

Adjustments

9. Using an open-end wrench, turn the hex shaft (D) three turns upwards (toward the frame) if the tractor is creeping forward, or downward (toward the ground) if the tractor is creeping backwards.
10. Hold hex shaft and tighten front and rear nuts.

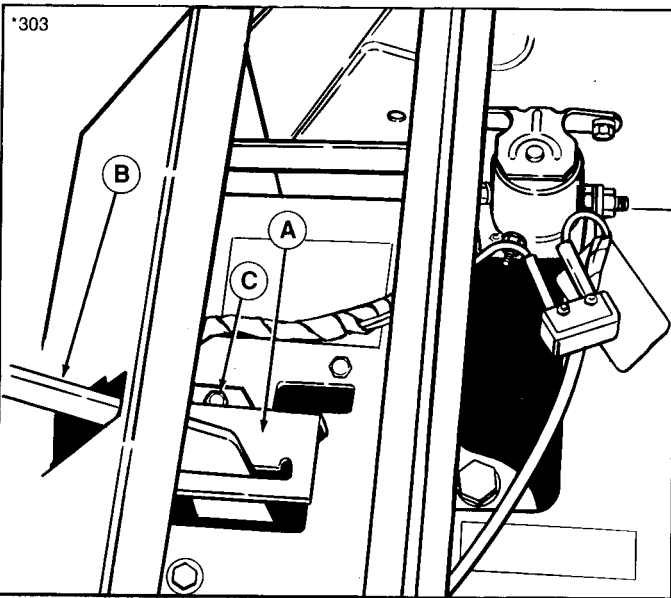

Figure 32. Control Lever Quadrant

- A. Quadrant
- B. Transmission Engagement Lever
- C. Taplite Screw

40

11. Repeat steps 1 through 7 to readjust the hydro lever in the neutral gate.
12. Repeat entire procedure until tractor does not creep with hydro lever in neutral gate.

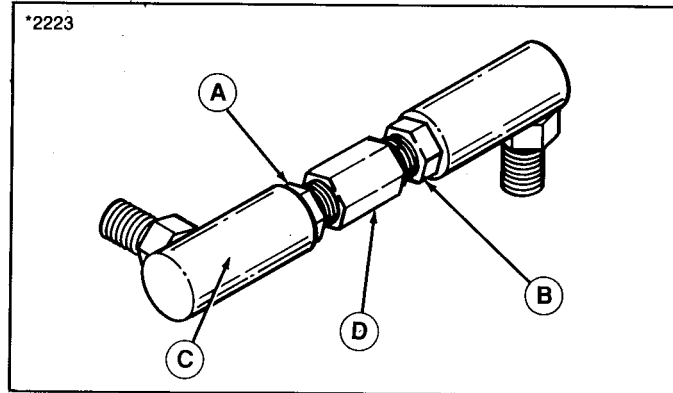

Figure 33.

- A. Front Jam Nut
- B. Rear Jam Nut
- C. Hydro Shift Lever
- D. Hex Shaft

MOWER ADJUSTMENTS**Mower Drive Belt Tension**

Using the mower lift lever, lower the mower. Using the height control lever, place the mower in highest cutting position. Place the PTO lever in engaged position. The gap between the rod guide (A, figure 34) and the set collar (B) should measure 3/8 to 1/2 inch (10 to 13 mm). If not, disengage the PTO. Loosen the setscrew (C). Move the rod forward to increase the gap or back to decrease the gap then tighten the setscrew. Engage the PTO and recheck the adjustment. Readjust if necessary.

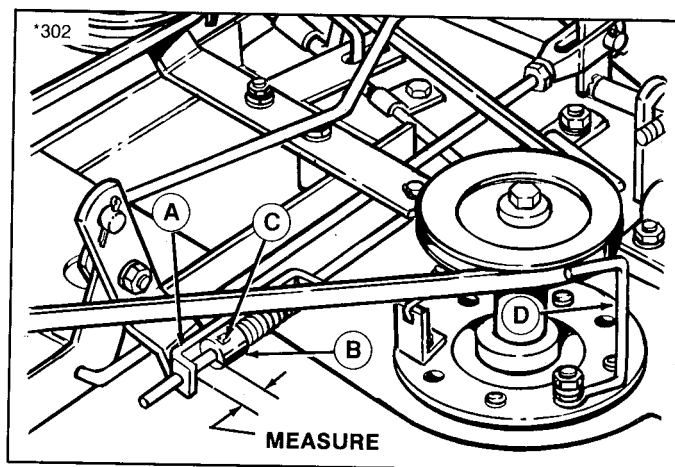

Figure 34. Drive Belt Tension
 A. Rod Guide C. Setscrew
 B. Set Collar D. Belt Stop

Arbor Belt Stops

The arbor belt stops are item D in figure 34 and item B in figure 35. There should be 1/8 inch (3 mm) clearance between the belt stops and belt when the PTO lever is engaged. If not, loosen the nut, move the belt stop and retighten the nut.

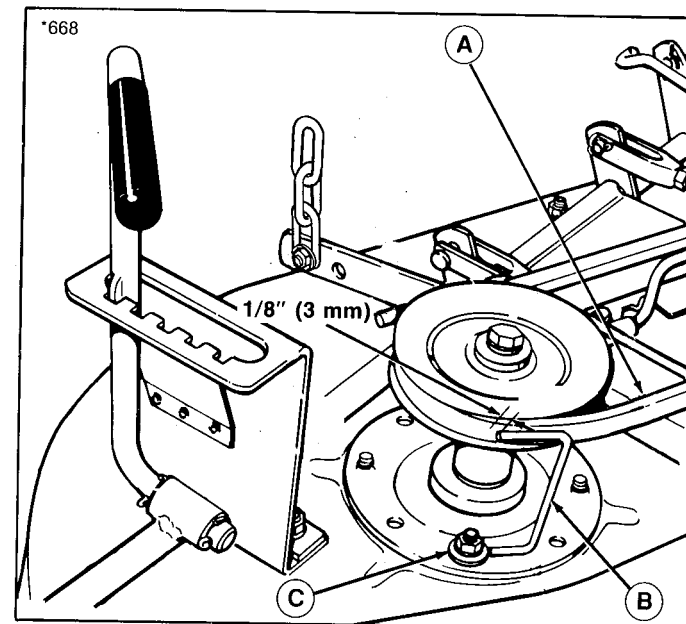

Figure 35. Right Arbor Belt Stop
 A. Belt B. Belt Stop C. Nut

Idler Pulley Belt Guide

The idler pulley belt guide is correctly adjusted when its edge is 1/4 inch (6 mm) from the rear edge of the idler arm (figure 36). If not, loosen the nut (C) and move the belt guide. Tighten the nut and recheck the measurement.

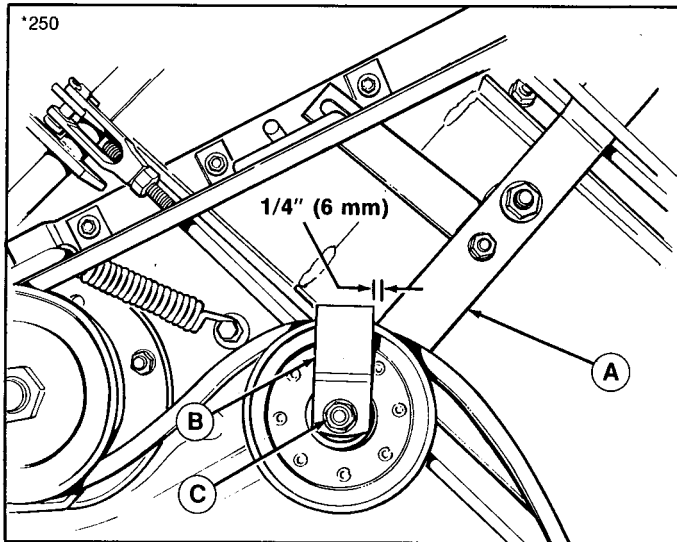

Figure 36. Idler Pulley Belt Guide

- A. PTO Idler Arm
- B. Belt Guide
- C. Nut

PTO Pulley Belt Stops

There are two belt stops at the PTO pulley; one on the left (figure 37) and one on the right (figure 38). With the PTO lever engaged, measure the distance between the belt stop and belt. There should be 1/16 inch (1.5 mm) clearance between each belt stop and the belt. To adjust a belt stop, loosen its mounting capscrew, move the belt stop, and retighten the capscrew. Recheck the measurement.

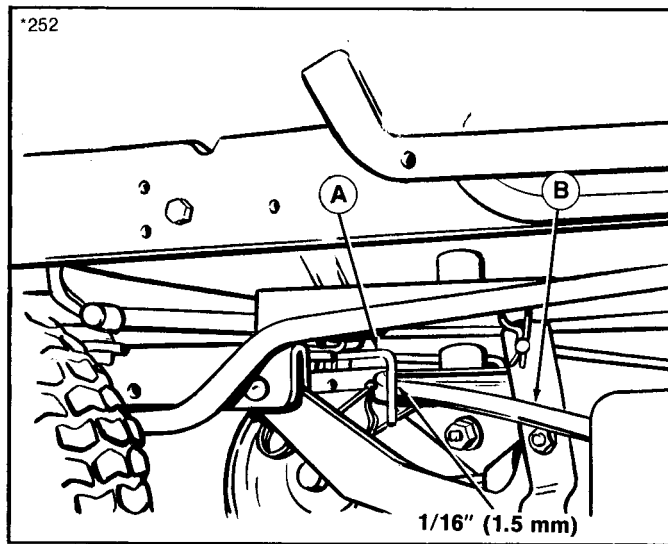

Figure 37. Left PTO Pulley Belt Stop

- A. Belt Stop
- B. Belt

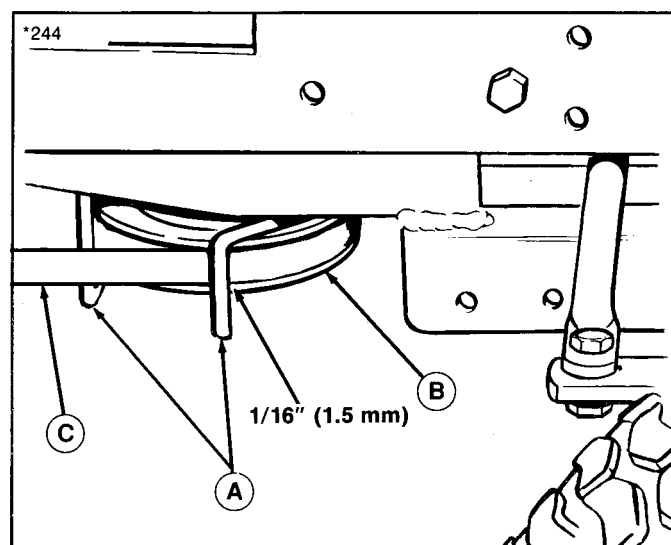

Figure 38. Right PTO Pulley Belt Stop

- A. Belt Stop
- B. PTO Pulley
- C. Belt

Leveling the Mower

If the cut is uneven, the mower may need leveling. Unequal or improper tire pressure may also cause an uneven cut. See page 21.



WARNING

To prevent accidental starting, remove the ignition key and then remove the spark plug wire and fasten it away from the spark plug.

1. With the mower installed, place the tractor on a smooth level surface, such as a concrete floor. Turn the front wheels straight forward.
2. Check for bent blades, and replace if necessary.
3. Disengage the PTO. Arrange the mower blades so that they are both pointing from side-to-side, perpendicular to the tractor. Engage the PTO.
4. Measure the distance between the outside tips of each blade and the ground. If there is more than 1/8 inch (3 mm) difference between the measurements on each side, proceed to step 5. If there is 1/8 inch (3 mm) or less difference, proceed to step 6.
5. Remove the cotter pin (E, figure 39) which secures the mower levelling rod (D). Shorten the rod (D) to raise the left side of the mower or lengthen the rod to lower the left side of the mower. Put the levelling rod back in its hole and recheck the measurements. If the mower is level, install the cotter pin (E).

Adjustments

6. Disengage mower PTO to arrange the blades so they are facing front to back, parallel with the tractor. Engage mower PTO again.
7. Measure the distance to the ground from the front tip of the left blade and the rear tip of the right blade. The measurements should be equal. If they are not, proceed as follows.

NOTE

One full turn of clevis will equal about 1/8 inch.

8. Remove the cotter pins and pins (B) from the hitch clevises (C). Loosen the two nuts (A). Turn each clevis an equal number of turns in the same direction. Shorten the hitch rods to raise the front of the mower or lengthen the hitch rods to lower the front of the mower.

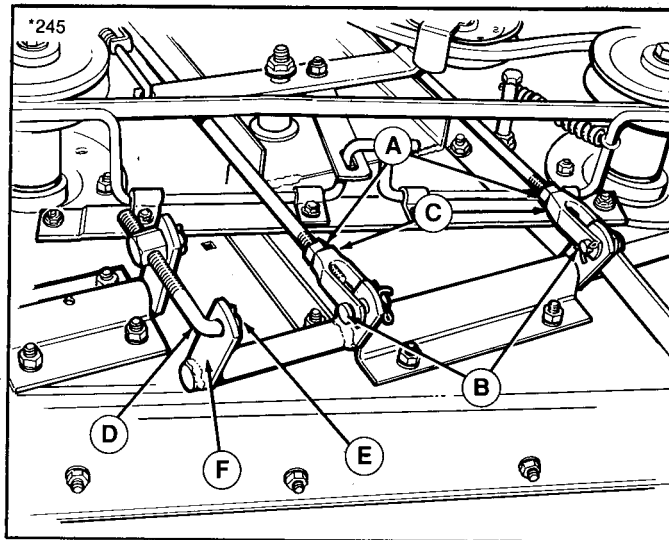

Figure 39. Leveling Mower

- A. Jam Nuts
- B. Pins
- C. Hitch Clevises
- D. Mower Levelling Rod
- E. Cotter Pin
- F. Suspension Arm

Blade Brake Adjustment

Inspect the mower deck with the mower attached and PTO rod released. The blade brake rods (A, figure 40) should firmly contact the belt (B) at the rear of the right and left arbor pulleys. There should be a shaft clearance between the two brake rods in the center.

To adjust blade brake rods, loosen the mounting brackets (C) and adjust rods for clearance. Retighten bracket bolts and check again. Engage the PTO and be sure that brake rods are at least 1/2" from belts.

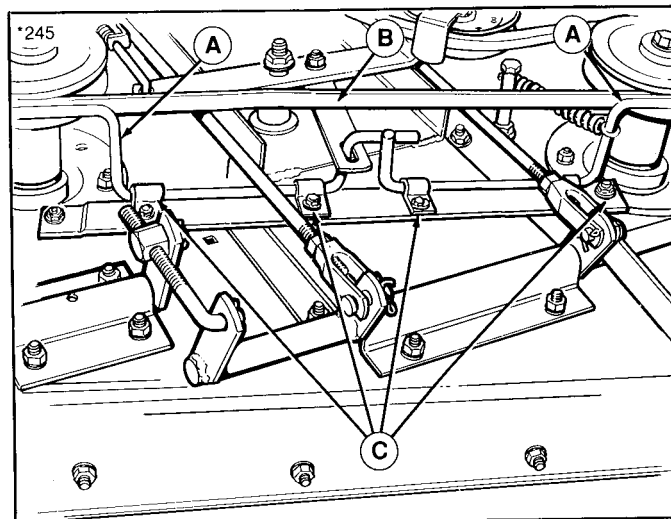

Figure 40. Blade Brake Adjustment
 A. Blade Brake Rods B. Belt C. Mounting Brackets

SMALL LIFT LEVER

NOTE

Use the procedure if small lift lever (E, figure 8) is used. If optional large lift lever (B, figure 8) is used, go to next procedure.

1. Place the mower in low cut position. Using the lift lever, raise the mower.
2. Measure the distance between top of upstop bracket and bottom of footrest (figure 41). The measurement should be 2-13/16 inches.
3. To adjust, disconnect clevis (E) from chain. Loosen nut (A) and turn clevis to raise or lower mower. Re-connect chain to check measurement. When correct, tighten nut against clevis.

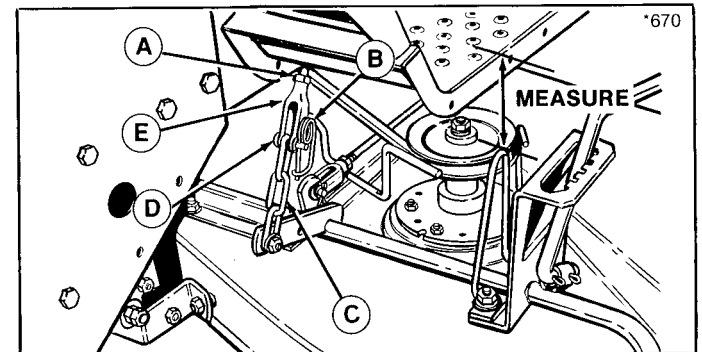

Figure 41. Lift Assembly - Small Lift Lever

- | | | |
|---------|----------|-----------|
| A. Nut | C. Chain | E. Clevis |
| B. Clip | D. Pin | |

LARGE LIFT LEVER

NOTE

Use this procedure if optional large lift lever (B, figure 8) is used. If small lift lever (E, figure 8) is used, see previous procedure.

1. Place the mower in low cut position.

2. Measure the distance from bottom edge of lever bracket to mower deck (figure 42).
3. The measurement should be 5 inches.
4. To adjust, disconnect trunnion (C, figure 43) from lift chain. Loosen the nut, and turn trunnion to raise or lower mower. Tighten nut when measurement is correct.

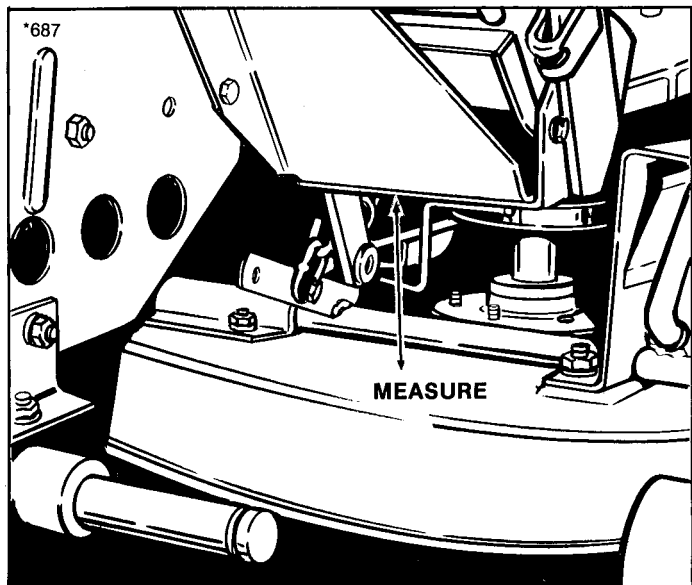

Figure 42. Measurement - Large Lift Lever

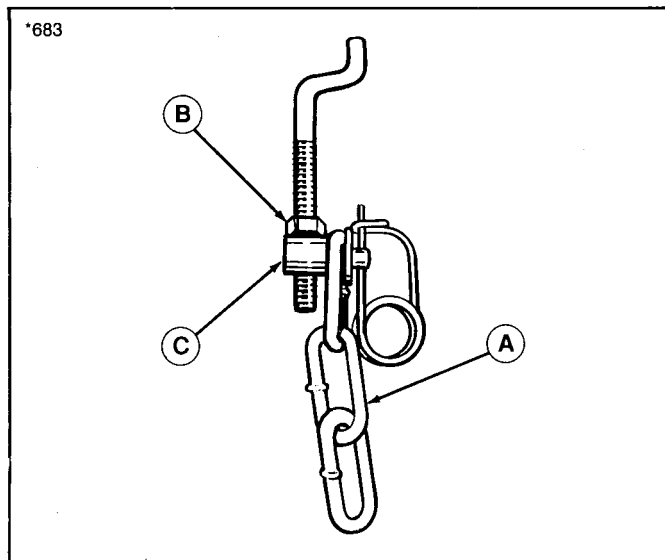

Figure 43. Lift Assembly - Large Lift Lever

- A. Chain
- B. Nut
- C. Trunnion

Specifications

BASIC ENGINE

Make: Briggs & Stratton - 4 cycle, air cooled

Model & Type: See engine I.D. plate

Horsepower: 12 HP @ 3600 rpm (Eng. Mfg's. Rating)

Cylinder: 1 horizontal

Bore & Stroke: 12 HP: 3.44 x 3.06 inches (87 x 78 mm)

Displacement: 12 HP: 28.4 cu. in. (465 cc)

Crankshaft: Vertical, syncrobalanced

Battery: 12 volt, 39 amp. hour

Governor: Mechanical, full throttle - no load setting
@ 3400 ± 100 rpm; idle speed @ 1750 ± 200 rpm

Crankcase Capacity: See engine manual

Ignition: Electronic

Charging: Unregulated 3-amp DC charging circuit

Air Cleaner: Oil foam with reuseable polyurethane element

Fuel Tank: 2.2 gallons (8.3 liters) of "regular" grade leaded or unleaded gasoline.

Starter: 12 volt electric gear drive

TRANSMISSION

Type: Belt drive to hydrostatic transmission

Differential: Gear reduction unit with bevel gears.

Ground speeds @ 3400 rpm:

Forward - 0 - 4.8 mph

Reverse - 0 - 2.6 mph

DIMENSIONS & WEIGHT

Height (at steering wheel): 39 in. (99 cm)

Width: 33.75 in. (88 cm)

Length: 65.25 in. (166 cm)

Clearance - Front Axle: 9 in. (228 mm)

Clearance - Transmission: 4.75 in. (120 mm)

Wheel Base: 45.5 in. (1156 mm)

Turning Radius: 24 in. (610 mm) to inside of rear wheel

Front Tires: 15 x 6.00 x 6 Pneumatic

Rear Tires: 18 x 8.50 x 8 Pneumatic

SPECIFICATIONS SUBJECT TO CHANGE WITHOUT NOTICE.

Common Replacement Parts

Listed below are part numbers for the more common replacement parts. Use the order form at the back of the manual to order a complete, illustrated parts manual. Only genuine Simplicity replacement parts will assure optimum performance and safety. Do not attempt repairs or maintenance unless proper procedures and safety precautions are followed. For assistance in any area, see your dealer.

<u>QTY</u> <u>PER</u> <u>UNIT</u>	<u>DESCRIPTION</u>	<u>PART</u> <u>NUMBER</u>
1	Drive Belt - engine to transmission	1656960
1	Drive Belt - mower	108505
1	Keys - Ignition (2 keys with ring)	122203
2	Headlight Lens	**1665933
2	Blade - Mower (standard)	1657589
3	Cotter Pin - levelling clevises & rod	1918447
1	Spring Clip - Mower PTO Rod	1960074
1	Cotter Pin - Mower PTO Rod	1918448
2	Hitch Pin - Mower	156306
2	Safety Clips - for Hitch Pins	176012
1	39 amp. hr. Battery	1685215
1	Fuel Filter	173206
1	Interlock Switch - PTO	1701580
1	Interlock Switch - Transmission	1665586
1	Interlock Switch - Seat	1700636
	Simplicity SAE 5W-30 Cold Weather Engine Oil	**1685576 (case of 12 qts.)
	Simplicity SAE 15W-40 SS/CD Engine Oil	**1685554 (case of qts.)

<u>QTY</u> <u>PER</u> <u>UNIT</u>	<u>DESCRIPTION</u>	<u>PART</u> <u>NUMBER</u>
	Grease Gun Kit (incl. tube grease)	1685510
	8 Oz. Tube - for above	103077
	Touch-Up Paint	
	Deep Orange Spray Paint, 13 Oz. Can	1685611
	Deep Orange Spray Paint (Case of 12 - 13 Oz. Cans)	1685614
	Deep Orange Paint, 1 Quart	1685612
	White Spray Paint, 13 Oz. Can	103049
	Touch-Up Daubers	
	Deep Orange (6 orange & 6 white - see your dealer for individual daubers.)	1685613
	Pneumatic Tire Seal - Stops Leaks Available in following amounts:	
	11 Oz. Tube	1685523
	Case of 24-11 Oz. Tubes	1685525

* Purchase the bulb (#199) from a local automotive supplier.

** See your dealer to buy individual quarts.

To order a parts manual, see page 51.

Optional Attachments & Accessories

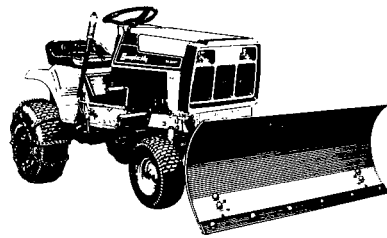

42" DOZER BLADE - For snow removal and light dozing of dirt, gravel, etc.

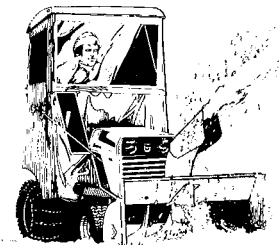

SNOW CAB - Shields operator from blowing snow and wind.

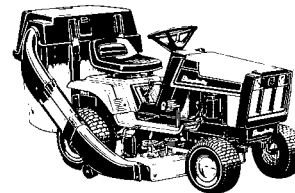

DELUXE TWIN CATCHER - For the best lawn appearance.

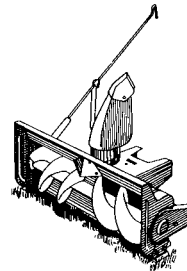

36" SNOWTHROWER - Efficient single stage operation to handle the heaviest of snows.

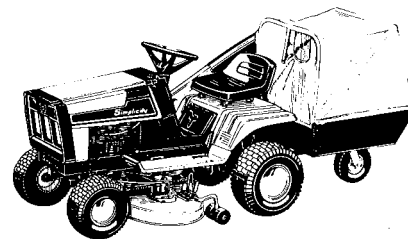

TURBO COLLECTION SYSTEMS - Can be used with either 6.5 bushel twin bag grass catcher or QuadBagger™.

TIRE CHAINS for traction

HOURMETER to record operating time.

FRONT WEIGHT to improve steering and stability with rear mounted attachment.

REAR WHEEL WEIGHTS to improve traction and stability.

DUMP CART for collection systems and hauling chores.

NOTE: Some attachments require accessories. See your dealer or the attachment operator's manual.

Parts Manual Available

Simplicity Parts Manuals are fully illustrated. All of the assemblies are shown in exploded views which show the relationship of the parts and how they go together. Important assembly notes and special torque values are included in the illustrations. For standard hardware, a torque specifications chart is included.

To order enclose the form with a check or money order made out to SIMPLICITY. Address the envelope to:

Simplicity Manufacturing, Inc.
Attn: Cashier
500 N. Spring Street
P.O. Box 997
Port Washington, WI 53074-0997

Parts Manual TP-1120 contains major attachments and service accessories for 12LTH tractors.

**Extend Equipment Life - Use Only Genuine
Simplicity Repair Parts.**

- I would like parts manual (TP-1163) for my 12LTH lawn tractor (Mfg. No. 1691931). Enclosed is a check or money order for \$5.50.
- I would like parts manual TP-1120 for 12LTH/4200 Series Attachments. I have specified the Mfg. Nos. for my attachment(s). Enclosed is a check or money order for \$5.50.
- Enclosed is \$1.50 for shipping and handling.

Attachment	Mfg. No.
1.	_____
2.	_____
3.	_____
4.	_____
5.	_____
6.	_____

Name _____ Tractor Mfg. No. _____
Street or RFD _____
City _____ State _____ Zip _____

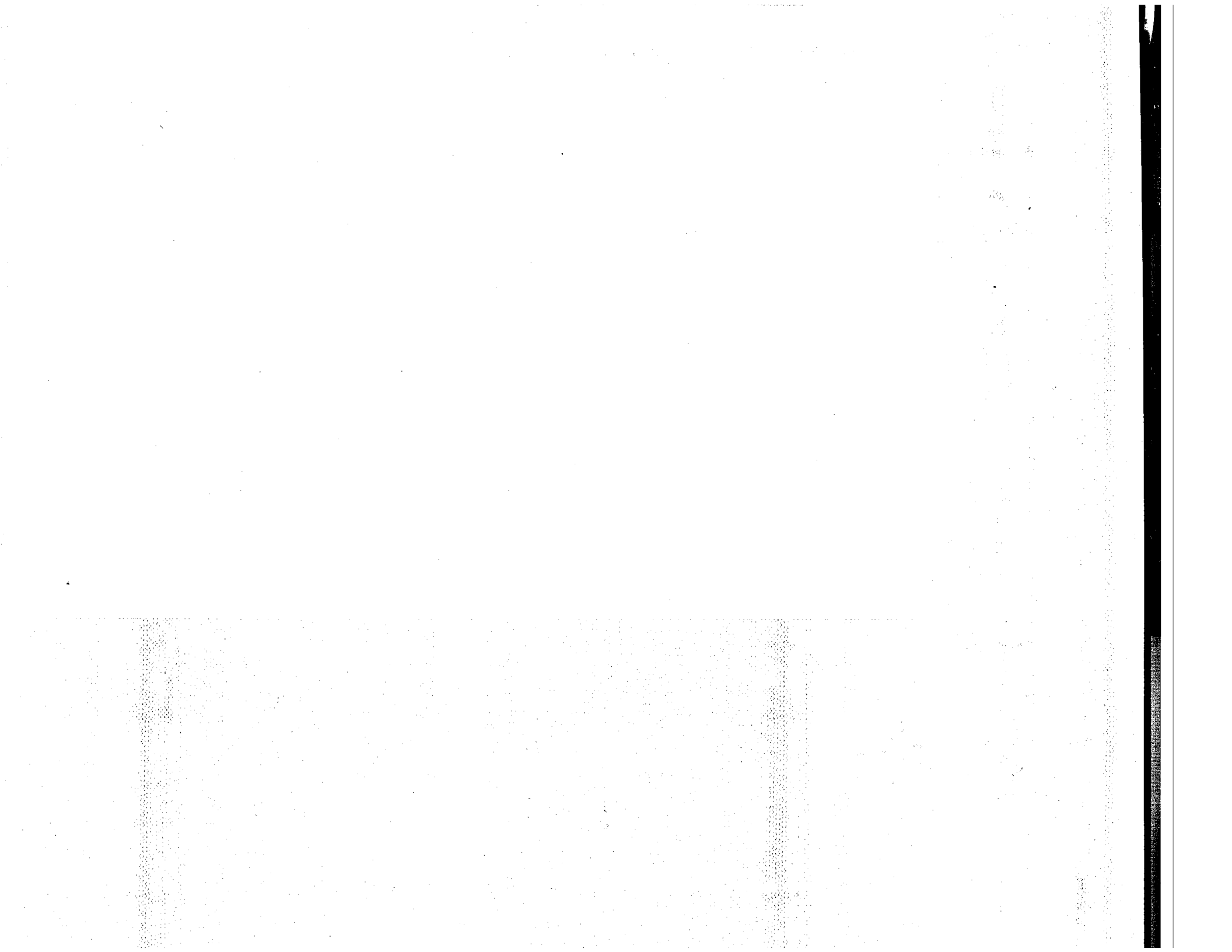

SIMPLICITY MANUFACTURING, INC.
500 N. Spring St., P.O. Box 997
Port Washington, WI USA 53074-0997

FORM - 1705893
PRINTED IN U.S.A.
©1990 6/90