

User's Manual

MR1400S
MR1400W

IN-DASH MARINE CD RECEIVER



BOSS[®]
AUDIO SYSTEMS

1. BUTTONS LOCATION AND FUNCTIONS

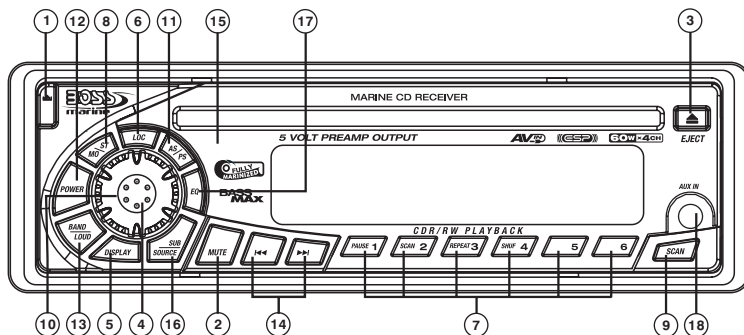

EN

1. Panel Release Button
2. Mute Button
3. CD Eject Button
4. Audio Button
5. Display Button
6. Local / Distant Button
7. Preset Memory Buttons
8. Mono / Stereo Button
9. Scan Button
10. Volume Knob
11. Automatically Store / Preset Scan Button
12. Power Button
13. Band/Loudness Button
14. Tuning Up/Down & Track Up / Down Buttons
15. Remote Control Receiver
16. Source Button
17. Preset Equalizer Button
18. Aux In Jack

PT

1. Tecla para remover o painel frontal
2. Tecla Mute
3. Tecla para ejetar o disco
4. Tecla de ajuste de audio
5. Tecla Display
6. Tecla Local/Distante
7. Teclas de memória de estações
8. Tecla estéreo/mono
9. Tecla Scan
10. Controle de volume
11. Tecla automática (As) /Preset Scan (Ps)
12. Tecla Ligar/desligar
13. Tecla Banda / Loudness
14. Teclas de sintonização de estações / mudança de faixas de música
15. Sensor do controle remoto
16. Tecla Source
17. Tecla Equalizador pré-programado
18. Entrada Auxiliar

DE

1. Entriegel-Taste Bedienteil
2. Stumm-Taste
3. CD-Auswurfaste
4. Audio-Taste
5. Display-Taste
6. Local / Distant-Taste
7. Senderspeichertasten
8. Mono / Stereo-Taste
9. Scan- Taste
10. Lautstärkenregler
11. AMS Taste
12. Einschalt-Taste
13. Frequenzband-Taste
14. Titel AUF / AB - Taste
15. Fernbedienungs-Taste
16. Source-Taste
17. PEQ-Taste
18. Front-Audio-Anschluss

ES

1. Extracción del panel frontal
2. Silenciamiento rápido
3. Apertura del panel motorizado y expulsión del disco
4. Tecla Audio
5. Selección información Display
6. Botón Distancia/Local
7. Botones de estaciones memorizadas
8. Botón selección mono/estéreo
9. Botón De Búsqueda
10. Botón De Volumen
11. Automática de emisoras/ selección de memorias
12. Encendido/Apagado
13. Selector Bandas
14. Botón de selección de emisoras & banda de música
15. Receptor de control remoto
16. Selección modos Radio/CD/Entrada auxiliar
17. Tecla de ecualización
18. Entrada de auxiliar

FR

1. Bouton De Déclenchement Du Panneau
2. Bouton D'assourdissement
3. Bouton Ejection D'un Cd
4. Bouton De Sélection Audio
5. Bouton D'écran / Affichage D'information
6. Bouton Local/distant
7. Boutons Des Stations Préréglées (m1 ~m6)
8. Bouton De La Stéréo Du Mono
9. Bouton Du Scanner
10. Bouton De Volume
11. Bouton De Stockage Des Stations Dans La Mémoire
12. Bouton D'alimentation
13. Bouton De Bande
14. Bouton De Recherche Des Stations/pistes : En Avant / En Arrière
15. Récepteur De La Commande À Distance
16. Bouton De Régime
17. Bouton De PEQ
18. Aux A Jack

IT

1. Tasto Rilascio Frontalino
2. Tasto Mute
3. Tasto Eject
4. Audio Controlla
5. Tasto Display
6. Bottone Distante Locale
7. Tasti Stazioni Memorie Preimpostate
8. Bottone di Stereo/Mono
9. Tasto Scan
10. Tasto Volume
11. Tasto AS/PS
12. Tasto Power
13. Tasto Banda/Forte
14. Tasto sintonizzazione su/gi & traccia su/gi
15. Destinatario di controllo remoto
16. Tasto Mode
17. Bottone di equalizzatore preprogrammato
18. Entrada Aux

2. HANDLING COMPACT DISCS

MOISTURE CONDENSATION

On a rainy day or in a very damp area, moisture may condense on the lenses inside the unit. Should this occur, the unit will not operate properly. In such a case, remove the disc and wait for about an hour until the moisture has evaporated.

NOTES ON CDs

1. A dirty or defective disc may cause sound dropouts while playing. To enjoy optimum sound, handle the disc as follows.
Handle the disc by its edge. To keep the disc clean, do not touch the surface (P.1).

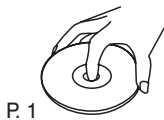

2. Do not stick paper or tape on the disc (P.2).



3. Do not expose the discs to direct sunlight or heat sources such as hot air-ducts, or leave them in a car parked in direct sunlight where there can be a considerable rise in temperature inside the car (P.3).



4. Before playing, clean the discs with an optional cleaning cloth. Wipe each disc from the center out (P.4).



5. Do not use solvents such as benzene, thinner, commercially available cleaners, or antistatic spray intended for analog discs.

NOTES ON DISCS

If you use the discs explained below, the sticky residue can cause the CD to stop spinning and may cause malfunction or ruin your discs.

Do not use second-hand or rental CDs that have a sticky residue on the surface (for example, from peeled-off stickers or from ink, or glue leaking from under the stickers).

**There are paste residue.
Ink is sticky (P.5).**



Do not use CDs with old labels that are beginning to peel off.

Stickers that are beginning to peel away, leaving a sticky residue (P.6).

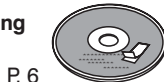

Do not use your CDs with labels or stickers attached.

Labels are attached (P.7).

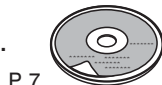

Do Not Use Special Shape CDs

Be sure to use round shape CDs only for this unit and do not use any special shape CDs. Use of special shape CDs may cause the unit to malfunction.(P.8).



Be sure to use CDs with disc mark



Only for this unit.

CD-Rs and CD-RWs which have not undergone finalization processing cannot be played. (For more information on finalization processing, refer to the manual for your CD-R/CD-RW writing software or CD-R/CD-RW recorder.) Additionally, depending on the recording status, it may prove impossible to play certain CDs record on CD-R or CD-RW.

3. INSTALLATION

- Before finally installing the unit, connect the wiring temporarily and make sure it is all connected up properly and the unit and system work properly.
- Use only the parts included with the unit to ensure proper installation. The use of unauthorized parts can cause malfunctions.
- Consult with your nearest dealer if installation requires the drilling of holes or other modifications of the vehicle.
- Install the unit where it does not get in the driver's way and cannot injure the passenger if there is a sudden stop, like an emergency stop.
- If installation angle exceeds 30° from horizontal, the unit might not give its optimum performance.

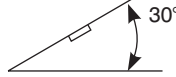

- Avoid installing the unit where it would be subject to high temperature, such as from direct sunlight, or from hot air, from heater, or where it would be subject to dust dirt or excessive vibration.
- Be sure to remove the front panel before installing the unit.

DIN FRONT/REAR-MOUNT

This unit can be properly installed either from “Front” (conventional DIN Front-mount) or “Rear” (DIN Rear-mount installation, utilizing threaded screw holes at the sides of the unit chassis). For details, refer to the following illustrated installation methods A and B.

DIN FRONT-MOUNT (Method A)

Installation the unit

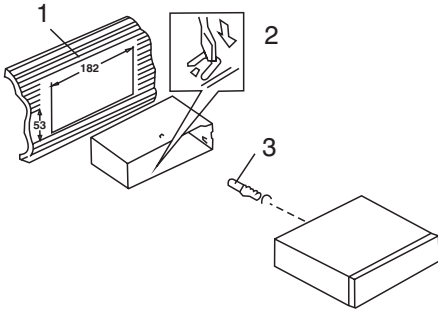

1. Dashboard
2. Holder
After inserting the half sleeve into the dashboard, select the appropriate tab according to the thickness of the dashboard material and bend them inwards to secure the holder in place.
3. Screw

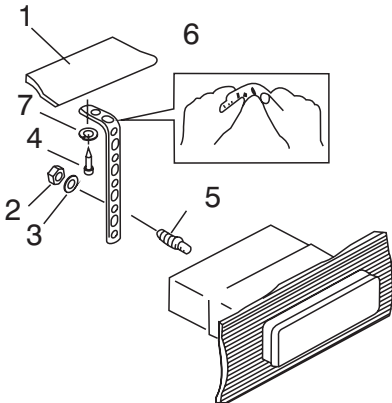

1. Dashboard
2. Nut (5mm)
3. Spring washer
4. Screw (5x15mm)
5. Screw
6. Support Strap
Be sure to use the support strap to secure the back of the unit in place. The strap can be bent by hand to the desired angle.
7. Plain washer

Removing the unit

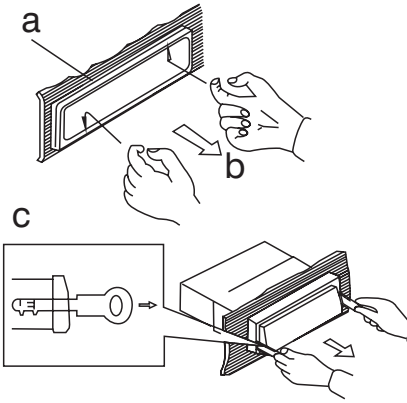

- a. Frame
- b. Insert fingers into the groove in the front of frame and pull out to remove the frame. (When re-attaching the frame, point the side with a groove down wards and attach it.)
- c. Insert the levers supplied with the unit into the grooves at both sides of the unit as shown in figure until they click. Pulling the levers makes it possible to remove the unit from the dashboard.

Trim Plate Installation:

Push the trim plate against the chassis until it is fitted.

You must do this before you install the front panel, otherwise it can't be attached.

DIN REAR-MOUNT (METHOD B)

Installation using the screw holes on the sides of the unit.
Fastening the unit to the factory radio mounting bracket.

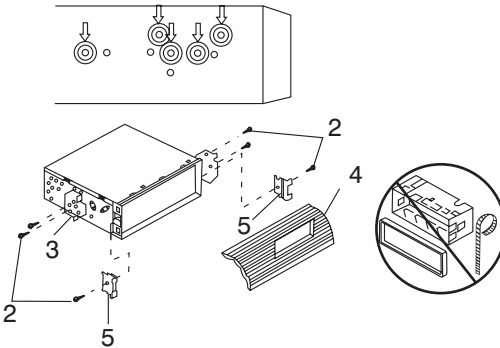

1. Select a position where the screw holes of the bracket and the screw holes of the main unit become aligned (are fitted) and tighten the screws at 2 places on each side.
2. Screw
3. Factory radio mounting bracket.
4. Dashboard or Console
5. Hook (Remove this part)

Note: the mounting box, outer trim ring, and half-sleeve are not used for method B installation.

4. DETACHABLE CONTROL PANEL (D.C.P.)

Removing The Detachable Control Panel (D.C.P.).



1. Turn the power off
2. Press the D.C.P. release button
3. Remove the D.C.P.

Attaching the DCP

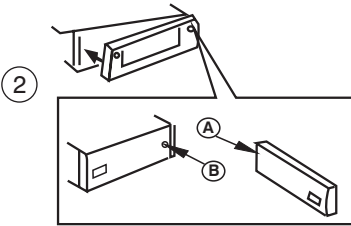

1. Attach the panel at the right side first, with point B on the main unit touching point A on the D.C.P. (As shown on the diagram).
2. Then press the left side of D.C.P. onto the main unit until a "click" sound is heard.

CAUTION

- DO NOT insert the D.C.P. from the left side. Doing so may damage it.
- The D.C.P. can easily be damaged by shocks. After removing it, place it in a protective case and be careful not to drop it or subject it to strong shocks.
- When the release button is pressed and the D.C.P. is unlocked, the car's vibrations may cause it to fall. To prevent damage to the D.C.P., always store it in a protective case after detaching it.
- The rear connector that connects the main unit and the D.C.P. is an extremely important part. Be careful not to damage it by pressing on it with fingernails, pens, screwdrivers, etc.

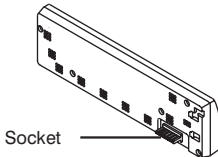

Note:

If the D.C.P. is dirty, wipe off the dirt with soft, dry cloth only. And use a cotton swab soaked in isopropyl alcohol to clean the socket on the back of the D.C.P.

6. BASIC OPERATIONS

1) PANEL RELEASE BUTTON (REL)

Press this button to remove the control panel.

12) POWER ON/OFF BUTTON

Press this button to turn on or off the power.

5) DISPLAY BUTTON (DISP)

Press this button briefly, the LCD will display the clock for about 2 seconds, then return to previous display mode.

Clock Adjustment

Under clock display mode, press DISP button until the LCD flashes, press Tuning Up Button to adjust hour and Tuning Down Button to adjust minute.

15) SOURCE BUTTON (SOURCE)

Press this button to select Radio and CD modes.

The available selections depends on version:

Radio CD Player

Radio > CD > AUX in

Sub-woofer On/Off

Press SOURCE button for more than 3 seconds to activate or turn off the Sub-woofer output.

17) FRONT (AND REAR PANEL) AUXILIARY INPUT JACKS

This unit features AUX IN line input jacks on both the front (headphone type) and rear (RCA type) panels.

PLEASE NOTE:

These two inputs cannot be used simultaneously. If you have a source unit plugged into the rear panel jack and wish to listen to a portable device (such as an MP3 player) by using the front panel jack, be sure to power off the unit plugged into the rear unit to avoid interference.

Similarly, if you have a device plugged into the front panel jack and wish to listen to the unit plugged into the rear panel, be sure to turn off the front panel device.

To select either the front or rear AUX IN device as a listening source, press the SOURCE button to select AUX mode. To cancel AUX IN listening, press SOURCE again.

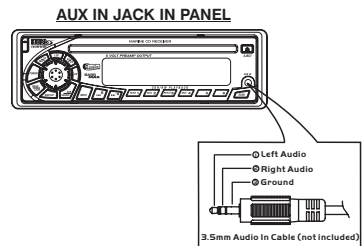

RESET BUTTON

The RESET button is located on the main unit (as shown on the diagram). To press it vertically with a ballpoint pen or metal object will activate it. The reset button is to be activated for the following reasons:

- Initial installation of the unit when all wiring is completed.
- All the function buttons do not operate.
- Error symbol on the display.

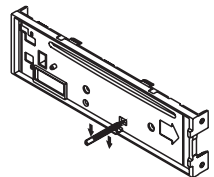

Note: If the unit cannot function normally after resetting, please use a cotton swab soaked in isopropyl alcohol to clean the socket on the back of the control panel.

7. AUDIO OPERATIONS

10) VOLUME KNOB

Turn this knob to adjust desired volume level.

4) AUDIO BUTTON

Press this button to select desired audio function.

ORDER OF FUNCTION:

VOLUME(VOL) -> BASS(BAS) -> TREBLE(TRE) ->BALANCE(BAL) ->FADER(FAD)

While the selected function is displayed, turn Volume Knob to adjust the level within 5 seconds, otherwise the unit will return to volume adjustment mode.

2) MUTE BUTTON (MUTE)

Press this button to mute the sound. Press it again to resume listening.

16) PRESET EQUALIZER BUTTON (EQ)

Press this button to toggle the following EQ settings:

FLAT->CLASSICS->POP M->ROCK M->DSP OFF

At DSP OFF mode, EQ will be controlled by Bass/Treble setting.

13) BAND/LOUDNESS BUTTON (BAND/LOUD)

Press the Band/Loudness Button for couple of seconds to switch the loudness on or off. When Loudness is on, display will show 'Loud On' for a few seconds.

8. RADIO OPERATIONS

11) AUTO MEMORY STORE/PRESET SCAN BUTTON (AS/PS)

1. PRESET SCAN: Press AS/PS button briefly to enter Preset Scan mode, it will scan all the preset stations in the memories, you can hear that it will stay on each station for about 5 seconds.
2. AUTO MEMORY STORE: Press AS/PS button for couple of seconds to enter Auto Store mode, this feature will automatically scan the current band and enter up to 6 strongest stations into the 6 preset memories. To stop Auto Store & Scan, press the AS/PS button again.

7) STATION PRESET BUTTONS (M1-M6)

1. Press these buttons briefly to recall the stored stations in the selected band.
2. Presetting stations manually, Press the BAND button to select the band for the stations to be preset. Use Tuning Up/Down to tune in the stations to be preset. Press the Preset button at which you want to store the station for at least 2 second. The preset number will appear on the display accompanied by a beep, this indicates that the station has been stored into memory.

13) BAND/LOUDNESS BUTTON (BAND/LOUD)

This a dual function button. Press this button shortly to change between BAND FM1, FM2, FM3 or AM bands. Press this button for couple of seconds to turn Loudness function on or off.

14) TUNING / SEEK UP AND TUNING / SEEK DOWN BUTTONS

1. Press these buttons briefly, and the unit will operate in AUTO SEARCH tuning mode, the radio will tune up or down to the next station and remain on that station.
2. Press these buttons for more than 2 seconds, operate as MANUAL SEARCH buttons, under this mode the tuning frequency will advance up or down rapidly when the button is pressed. If the buttons are not pressed within 3 seconds, they will return to auto search mode.

8) MONO STEREO BUTTON (MO/ST)

When you receive a station, "ST" on the display will be on. Press this button to enter Mono mode.

9) SCAN BUTTON(SCAN)

Press this button, the radio will tune up to search stations, the available stations will blink and stay on the display for a few seconds.

6) LOCAL/DISTANT BUTTON (LOC)

During station tuning, this button allows you prior to access strong local station only (Local mode), or to access a wider range of using distant mode (DX). When powered on, DX mode will be defaulted automatically; Press LOC button briefly to select Local mode and "LOCAL" symbol on the LCD will light up for a few seconds.

9. CD OPERATIONS

M1) PAUSE BUTTON (PAUSE)

Press this button to pause CD play, press again to release pause.

M2) SCAN BUTTON (SCAN)

Press this button, the first 10 seconds of each track will be played sequentially until this button is pressed again, then normal play will resume at the current track.

M3) REPEAT BUTTON (REPEAT)

Press this button, the current track will be played repeatedly until this button is pressed again.

M4) SHUFFLE BUTTON (SHUFFLE)

Press this button to play all tracks on CD in random. Press again to deactivate it.

14) TRACK UP AND TRACK DOWN BUTTON

Press the Track Up Button to skip to the next track or previous track. Press the Track Down button during play will return to the beginning of the current track, press it one more time to skip to previous skip. Press and hold Track Up/Down Button to fast forward or fast reverse. CD player starts playing when you release the button.

EJECT BUTTON ▲

Press this button to eject the CD from the unit. The receiver will switch to radio mode automatically.

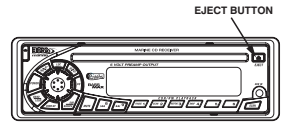

12. SPECIFICATIONS

EN

CD PLAYER

System	Compact disc audio system
Usable disc	Compact disc
Sampling frequency	44,1KHz
No of quantization bits	1bit
Frequency	5-20,000Hz
Number of channels	2 stereo
S/N Ratio	70dB

RADIO SECTION

FM	
Frequency Range	87.5-107.9MHz
Intermediate Frequency	10.7 MHz
Usable Sensitivity	Better than 15dB at S/N 30 dB
Stereo Separation	25 dB at 1KHz
S/N Ratio	50 dB

AM/MW

Frequency Range	530-1710KHz
Intermediate Frequency	450KHz
Usable Sensitivity	Better than 45dB
S/N Ratio	40 dB

GENERAL

Power Supply	DC 11 -14V
Polarity	Negative Ground
Speaker impedance	4 ohms
Power Output	4x 50 Watts

REMARK :

Specifications subject to change without notice.

DE

CD PLAYER

System	Compact Disc Audio System
Abspielbare Discs	Compact Disc
Sampling-Frequenz	44,1 kHz
Anzahl Quantisierungsbits	1 bit
Frequenz	5-20,000Hz
Anzahl Kanäle	2 Stereo
Signalrauschabstand	70 dB

RADIOTEIL

FM	
Frequenzbereich	87.5-107.9MHz
Zwischenfrequenz	10,7 MHz
Nutzbare Empfindlichkeit	Besser als 15 dB bei einem Signalrauschabstand von 30 dB
Stereotrennung	25 dB bei 1 kHz
Signalrauschabstand	50 dB

AM/MW

Frequenzbereich	530-1710KHz
Zwischenfrequenz	450KHz
Nutzbare Empfindlichkeit	Besser als 45 dB
Signalrauschabstand	40 dB

ALLGEMEINES

Stromversorgung	DC 11 -14 V
Polarität	Erde negativ
Lautsprecherimpedanz	4 Ohm
Ausgangsleistung	50 W x 4

ANMERKUNG:

Technische Änderungen ohne Meldepflicht vorbehalten.

FR

LECTEUR CD

Système	Compact disc audio system
Disques utilisables	Compact disc
Fréquence échantillonnage	44,1KHz
Nbre de quantisation bits	1bit
Fréquence	5-20,000Hz
Nombre de canaux	2 stéréo
Ratio S/B	70dB

SECTION RADIO

FM	
Gamme de fréquences	87.5-107.9MHz
Fréquence intermédiaire	10.7 MHz
Sensibilité utilisable	Plus de 15dB à S/B 30 dB
Séparation stéréo	25 dB à 1KHz
Ratio S/B	50 dB

AM/MW

Plage de fréquences	530-1710KHz
Fréquence intermédiaire	450KHz
Sensibilité utilisable	Supérieure à 45 dB
Rapport Signal/Bruit	40 dB

GENERAL

Alimentation	11 -14V DC
Polarité	Masse / négative
Résistance des enceintes	4 ohms
Puissance de sortie	50W x 4

REMARQUE :

Les spécifications sont susceptibles d'être modifiées sans préavis.

PT

CD Player

Sistema:	Sistema áudio CD
Tipo de disco:	CD
Frequência de Amostragem:	44.1KHz
Conversor D/A:	1bit
Resposta de frequência	5-20,000Hz
Número de canais:	2 estéreo
Relação sinal/ruído:	70dB

Rádio FM

Faixa de Frequência:	87.5-107.9MHz
Frequência Intermediária:	10.7 MHz
Sensibilidade útil:	melhor que 15dB a S/N 30dB
Separação estéreo	25 dB at 1KHz
Relação Sinal/Ruído	50 dB

AM/MW

Faixa de frequência:	530-1710KHz
Frequência intermediária:	450KHz
Sensibilidade útil:	Melhor do que 45dB
Relação Sinal/Ruído:	40dB

Geral:

Alimentação:	DC 11-14V
Polaridade:	Terra negativo
Impedância alto-falantes:	4ohms
Potência de saída:	50w x 4

Nota:

As especificações estão sujeitas a alterações sem prévio aviso.

ES

CD PLAYER

Sistema:	Compact disc audio system.
Disco:	Compact Disc.
Frecuencia Muestreo:	44.1KHz.
Cuantificación:	1bit.
Frecuencia:	5-20,000Hz.
Número de canales:	2 stereo.
Relación señal/Ruido S/N Ratio	70dB

RADIO SECCIÓN

FM	
Rango Frecuencia:	87.5-107.9MHz
Frecuencia Intermedia:	10.7MHz.
Sensibilidad Util:	Mejor que 15dB a S/N 30dB.
Separação estereo:	25dB a 1KHz.
S/N Ratio:	50dB.

AM/MW

Rango Frecuencia:	530-1710KHz
Frecuencia Intermedia:	450KHz.
Sensibilidad útil:	Mejor que 45dB.
S/N Ratio:	40dB.

GENERAL

Alimentación:	DC 11-14V.
Polaridad:	Negativo a masa.
Impedancia altavoces:	4 Ohms.
Potencia de salida:	4x50W.

Nota:

Debido al rápido avance tecnológico, estas especificaciones están sujetas a cambios sin previo aviso.

IT

LETTORE CD

Sistema	Sistema di Audio CD
Tipo di disco	CD
Frequenza di campionatura	44.1KHz
N° quantizzazioni Bit	1 bit
Frequenza	5-20,000 Hz
Numero di Canali	2 stereo
Rapporto S/N	70dB

SEZIONE RADIO

FM	
Raggio di Frequenza	87.5-107.9MHz
Frequenza intermedia	10.7 Mhz
Sensibilità	migliore di 15dB a S/N 30 dB
Separazione Stereo	25dB a 1KHz
Rapporto S/N	50dB

AM/MW

Raggio di Frequenza	530-1710KHz
Frequenza intermedia	450KHz
Sensibilità	migliore di 45dB
Rapporto S/N	40dB

GENERALE

Alimentazione	Dc11 14V
Polarità	Terra negativo
Impedanza altoparlanti	4 ohms
Potenza d'uscita	4x 50 Watts

Le specifiche sono soggette a cambiamenti senza alcun preavviso.

11.TROUBLE SHOOTING

Before going through the check list, check wiring connection. If any of the problems persist after check list has been made, consult your nearest service dealer.

Symptom	Cause	Solution
No power	The car ignition is not on.	If the power supply is properly connected to the car accessory terminal, switch the ignition key to "ACC"
	The fuse is blown.	Replace the fuse.
Disc cannot be loaded or ejected	Presence of CD disc inside the player.	Remove the disc in the player, then put a new one.
	Inserting the disc in reverse direction.	Insert the compact disc with the label facing upward.
	Compact disc is extremely dirty or defective disc.	Clean the disc or try to play a new one.
	Temperature inside the car is too high.	Cool off or until the ambient temperature returns to normal.
	Condensation.	Leave the player off for an hour or so, then try again.
No sound	Volume is in minimum.	Adjust volume to a desired level.
	Wiring is not properly connected.	Check wiring connection.
The operation keys do not work	The built-in microcomputer is not operating properly due to noise.	Press the RESET button. Front panel is not properly fixed into its place
Sound skips.	The installation angle is more than 30 degrees.	Adjust the installation angle to less than 30 degrees.
	The disc is extremely dirty or a defective disc.	Clean the compact disc or try to play a new one.
The radio does not work. The radio station automatic selection does not work.	The antenna cable is not connected.	Insert the antenna cable firmly.
	The signals are too weak.	Select a station manually.
ERROR 1	Mechanism Error	Press the reset button if the error code does not disappear, consult your nearest service dealer.
ERROR 2	Servo Error	Press the reset button if the error code does not disappear, consult your nearest service dealer.



If at any time in the future you should need to dispose of this product please note that Waste electrical products should not be disposed of with household waste. Please recycle where facilities exist. Check with your Local Authority or retailer for recycling advice.(Waste Electrical and Electronic Equipment Directive)



BOSS
marine

MR1400S • MR1400W
IN-DASH MARINE CD RECEIVER

10.2006

tech support: www.bosssaudio.com/support



10 R - 02 1397

BOSS[®]
AUDIO SYSTEMS

BOSS Audio Systems • 3451 Lunar Court • Oxnard, CA 93030

www.bosssaudio.com

800.999.1236