

THIEL

Ultimate Performance Loudspeakers

SCS4

Coherent Source[®]
loudspeaker system



OWNER INFORMATION

Congratulations on your purchase of the THIEL SCS4. This product is the result of a dedicated effort to provide very accurate and realistic sound reproduction. We have used very high quality components and taken great care in the SCS4's construction. Properly set up and used with good associated equipment, the SCS4 will provide you with a great deal of sonic enjoyment for many years.



Jim Thiel, Product Designer, THIEL Loudspeakers

SPEAKER PLACEMENT

The SCS4 is specifically designed to give a high level of performance from a variety of room locations and positions. They can be placed on bookshelves or on stands, and oriented horizontally or vertically while still providing a degree of realism not usually obtainable under unusual or difficult placement conditions. Because the SCS4 is magnetically shielded, it can be placed on or near video displays without causing picture distortion.

All aspects of speaker placement are dependent on the particular room. Since every room is different, no hard rules can be given, and experimentation is necessary to achieve the best results.

CONNECTING THE SPEAKERS

The SCS4's input terminals are located on the rear of the speaker. The SCS4 uses a 5-way binding post which accepts several types of speaker cable termination. *Make sure that all connections are tight.* The input terminals are designed to be easily tightened by hand or a ½ inch nut driver can be used.

It is essential for proper performance that both speakers in a stereo system be wired in the same polarity. The speaker's input terminals are color coded to facilitate this. The wire connected to the red ringed input terminal of each speaker should connect to the respective positive (+) output terminals of the amplifier; the wire connected to the black ringed input terminals should be connected to the respective negative (-) output terminals of the amplifier.

The speakers should be connected to the amplifier with high quality cable to ensure minimal loss of power and proper control by the amplifier. If the speakers are being connected to a vacuum tube amplifier with various impedance taps, the 4 ohm tap will usually give the best results.



Rear input panel

BREAK-IN

The SCS4's, like most speakers, require a period of playing before they perform optimally. The time depends on how loudly the speakers are played; more time is required if played softly, less if played loudly. At least 50 hours at moderately loud levels are required before the speaker is performing near optimum. You should notice even more improvement after 100 hours of playing.

ASSOCIATED EQUIPMENT

The SCS4 is a very high quality sound reproducer and will benefit from use with the best associated equipment. Since it is extremely accurate, it will reveal sources of distortion generated elsewhere in the system. For example, distortion resulting from poor recordings or inferior electronics will be reproduced accurately. Also, the quality of the interconnect cables and speaker cables will significantly effect the performance of the system.

POWER REQUIREMENTS

It is important to have enough power to play at the level you desire without distortion. If you play the speakers more loudly than the volume the amplifier can cleanly produce, the amplifier will produce overload (clipping) distortion. The sound will become compressed, strained, and in extreme cases, obviously distorted. This distortion is actually non-musical *additional energy* and since it is concentrated in the high frequency region where the speaker is least able to handle it, tweeters can be damaged in extreme cases. If high sound levels are desired, the SCS4's are designed to be used with amplifiers rated up to 200 watts per channel.

Keep in mind that sound *quality* is usually more important than sound *quantity*. There can be large differences in the sonic performance of two amplifiers of equal power, and this is more important than large differences in power. Most everyone will be happier with a 100 watt amplifier of high sonic quality than a 200 watt amplifier of mediocre sonic quality. For this reason, we feel there is no substitute for listening in making your amplifier decision.

The question "how much power do I need?" does not have the simple answer most people expect because it is not determined only by the loudspeaker's efficiency, but also by the volume desired and the size of the room. If all three factors are average, about 100 watts per channel is required. Each factor can raise or lower this amount by about three times.

1) Usually, people who "don't like music loud" can decrease their power to about one-half. Also, people who like music loud should increase their power by 2 times or more. Most people fall within a normal range.

2) A speaker with a low efficiency of 84dB/2.8 V-1-m will require twice the power of an average 87dB/2.8 V-1-m speaker and one with a high rating of 90dB/2.8 V-1-m will require only half the power of an average speaker. The SCS4 is of average efficiency (88dB) and therefore can achieve average output levels with an average amount of power.

3) A small room will need less power for a given loudness level than a large room. A very small room of 1000 cu ft (11' x 11' with an 8' ceiling) will require about half the power of an average size room. A large room of 6000 cu ft (20' x 30' with a 10' ceiling) will require twice the average power. If the listening room is connected to another room by a large open area, the required power will increase, but not by the amount of the combined room volume. If the room has a "dropped" ceiling with light panels, the ceiling will be almost transparent acoustically and the space above the ceiling should be added. If the panels are heavy they will act as a more normal ceiling.

With all this in mind, a person who doesn't like to play music very loudly and has a small room can get quality sound with the SCS4 with 30 watts or even less whereas a person who sometimes likes to play loudly and has a large room may need 200 watts or more.

CABINET FINISH CARE

THIEL Loudspeakers wood cabinets possess a high quality lacquer finish that is both beautiful and durable. However, any wood finish can be damaged by excessive moisture, dryness, or direct sunlight. When cleaning your speakers, avoid using oils, waxes, or polishes that contain silicone, such as Pledge or Johnson's. We recommend using Endust.

SERVICE

If your speaker system requires service, contact your authorized THIEL Loudspeakers dealer. If you need to contact THIEL Loudspeakers directly, service information and technical support is available at (859) 254-9427, Monday-Friday, 8:30 a.m. - 5:00 p.m. Eastern Time, or via e-mail at service@thielaudio.com. THIEL Loudspeakers dealer information and a "Frequently Asked Questions" section can be found at our web site, www.thielaudio.com.

We Want You Listening For A Lifetime

Used wisely, your new sound equipment will provide a lifetime of enjoyment. Since hearing damage from loud noise is often undetectable until it is too late, **THIEL** Loudspeakers and the Electronics Industries Manufacturers Association recommend you avoid prolonged exposure to excessive noise. Depending on room size and amplifier power, some home audio systems can reach sound pressure levels in excess of 95 decibels with peaks of over a 105 decibels. For your protection, the list below identifies sound levels for various noises.

Decibel

Level Example

| | |
|----|--|
| 30 | Quiet library, soft whispers |
| 40 | Living room, refrigerator, bedroom away from traffic |
| 50 | Light traffic, normal conversation, quiet office |
| 60 | Air conditioner at 20 feet, sewing machine |
| 70 | Vacuum cleaner, hair dryer, noisy restaurant |
| 80 | Average city traffic, garbage disposals, alarm clock at two feet |

The Following Noises Can Be Dangerous Under Constant Exposure

| | |
|-----|--|
| 90 | Subway, motorcycle, truck traffic, lawn mower |
| 100 | Garbage truck, chain saw, pneumatic drill |
| 120 | Rock concert in front of speakers, thunderclap |
| 140 | Gunshot blast, jet plane |
| 150 | Rocket launching pad |

Information courtesy of the Deafness Research Foundation and the EIA.



THIEL SCS4 SPECIFICATIONS

| | |
|---------------------------|-----------------------------|
| Amplitude Response | 47 Hz-20 kHz, -3 dB |
| Phase Response | Minimum $\pm 10^\circ$ |
| Sensitivity | 88 dB@2.8 V-1m |
| Impedance | 4 ohms (3 ohms minimum) |
| Recommended Power | 30-200 watts |
| Size | 8.4 " W x 10.8" D x 17.6" L |
| Weight | 25 pounds |

THIEL SCS4 CABINET DIMENSIONS

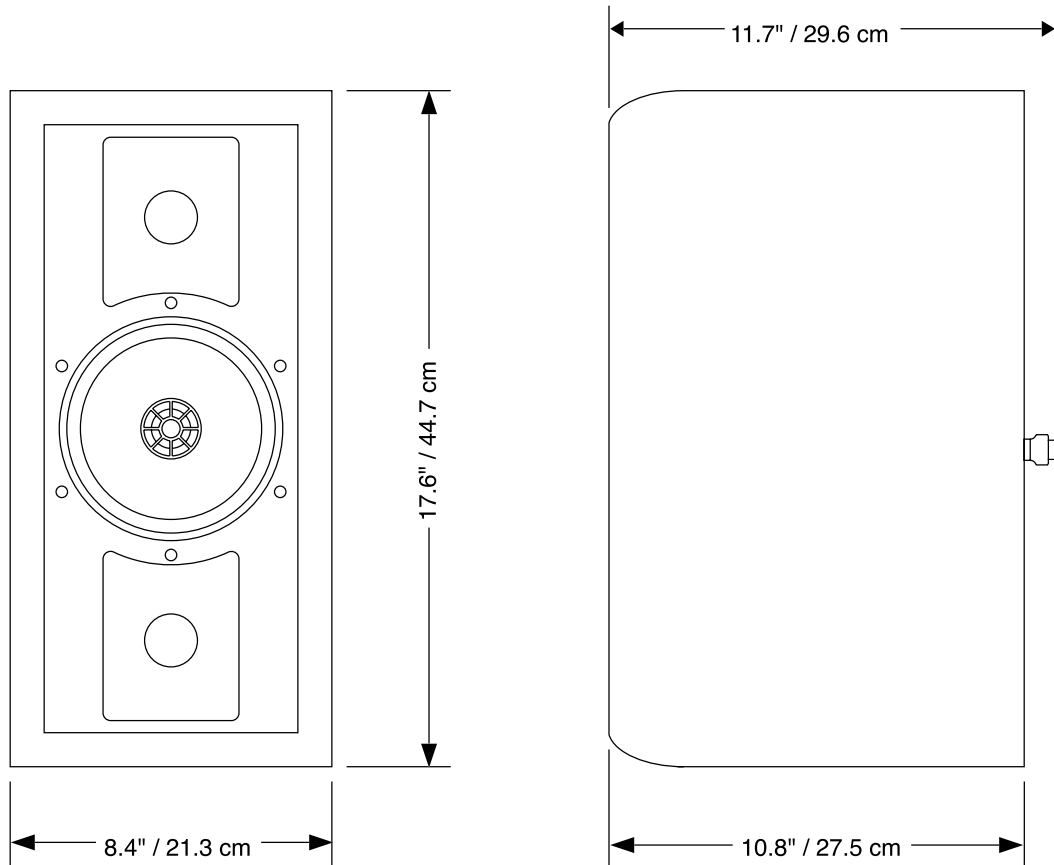

LIMITED WARRANTY

THIEL warrants every THIEL model SCS4 system against defects in materials and workmanship to the original owner for a period of ten years from the date of purchase. THIEL will, at no charge, replace any defective part and make any repairs necessary to ensure its proper performance when the defective unit is returned to us postpaid.

This warranty does not cover damage due to accident or abuse and is void if the unit has been tampered with.

This warranty is automatic and no registration is required. This warranty gives you specific legal rights. You may also have other rights which are particular to your state.

The following information is for your records.

Serial Numbers _____

Purchase Date _____

Purchased From _____

You can also register your warranty online at www.thielaudio.com/registrations/new



THIEL

1026 Nandino Boulevard
Lexington, Kentucky 40511-1207

Telephone: 859-254-9427 • E-mail: mail@thielaudio.com • Web: www.thielaudio.com