

OPERATOR'S MANUAL

60" ROTARY MOWER

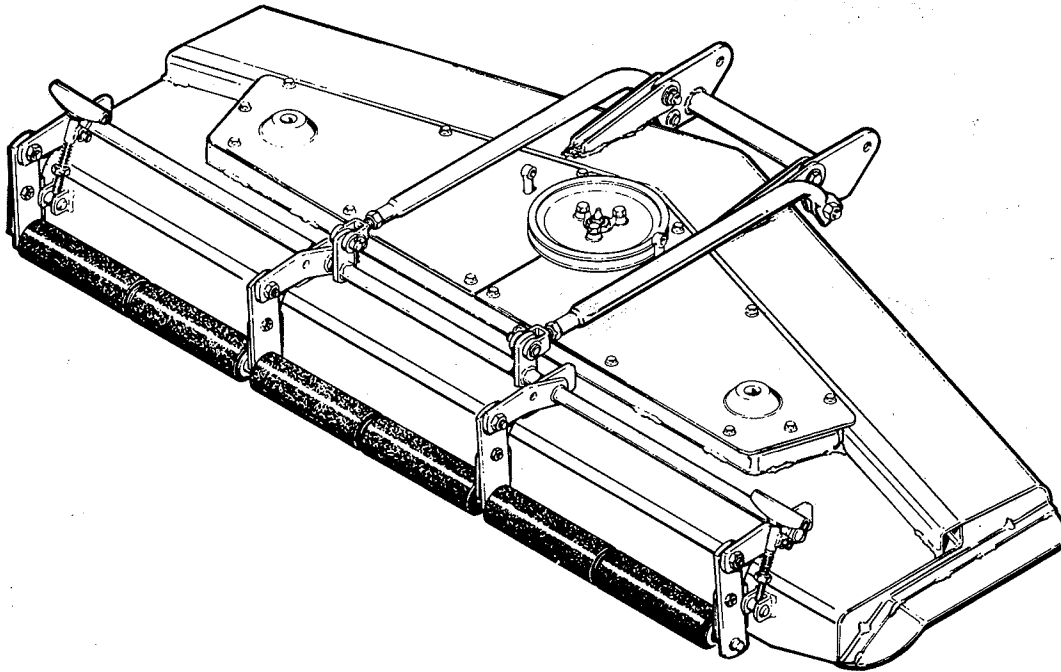

60" ROTARY MOWER
MFG. NO. 1690074

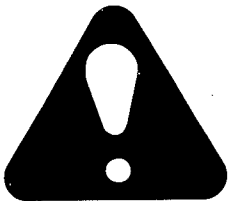

**CAUTION: Read Manual Thoroughly
Before Operating Mower**

FORM - 1652001
PRINTED IN U.S.A.
7612

Dear Customer,

Congratulations on your purchase of this mower. It has been carefully designed and built to meet or exceed current O.P.E.I. certification requirements, according to ANSI Safety Specification B71.1a-1974, and has been certified by an independent testing laboratory. With proper use and care, it will help you do your mowing jobs efficiently.

To make sure you get the best use from your rotary mower, study this manual carefully. Make sure that it is installed properly. Be sure that you (and anyone who operates this machine) know how to use the machine safely. Read this manual and the tractor manual thoroughly and become familiar with the controls of the machine before operating.

For your own safety as well as others, study the safety rules in this manual and those in the tractor manual. Review this information often. It is there for your benefit and is important.

This manual tells how to install, service, and operate your rotary mower. If any help is needed with any of these procedures, your dealer will be happy to help you.

Measurements are given in this manual with metric equivalents in parentheses. For example, behind the measurement 1/8 inch would appear: (3 mm). So, the metric equivalent of 1/8 inch is 3 millimetres.

These metric measurements are provided for your convenience as an aid in converting to the metric system. A list of metric terms and abbreviations used in this manual is provided below.

LIST OF ABBREVIATIONS OF METRIC TERMS

1. mm = millimetre
2. kg = kilogram
3. N·m = newton-metre
4. m = metre

60 Inch Rotary Mower

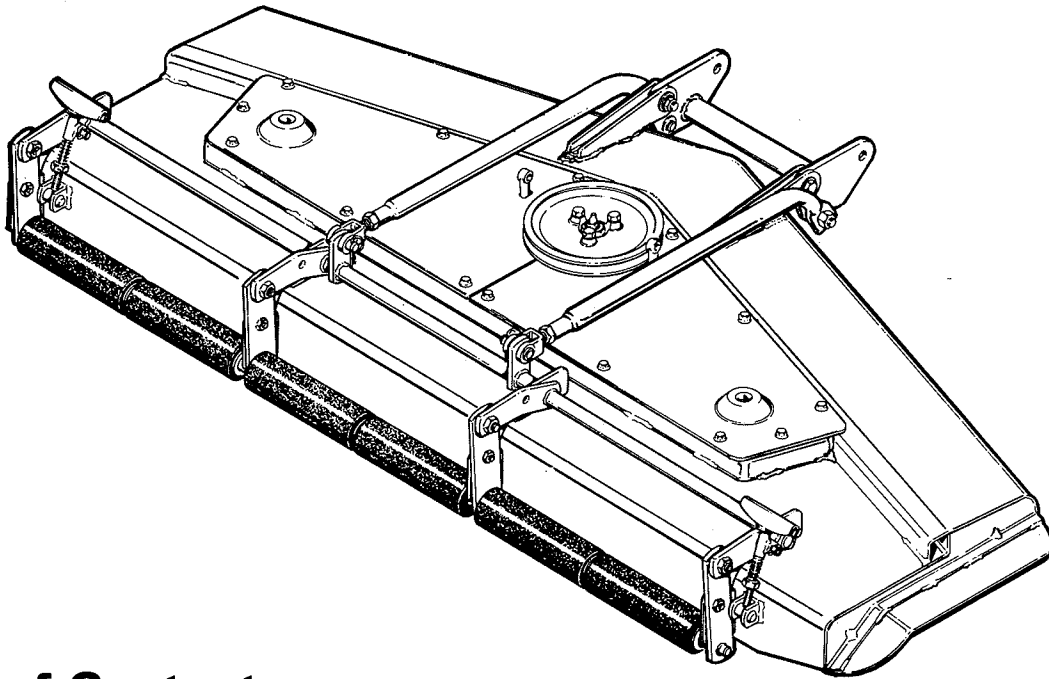

Table of Contents

SAFETY RULES	2
IDENTIFICATION	4
SPECIFICATIONS	4
ACCESSORIES AND ATTACHMENTS	4
INSTALLATION	5
REQUIRED ACCESSORY	5
INSTALLATION	5
REMOVAL	7
OPERATION	8
NORMAL CARE	11
SCHEDULED CARE	11
NORMAL STORAGE	11
OFF-SEASON STORAGE	11
MAINTENANCE RECORD	14
TROUBLESHOOTING	15
TROUBLESHOOTING PROCEDURES	15
BELT REPLACEMENT	16
ADJUSTMENTS	17
BELT TENSION	17
BELT CLEARANCE	17
MOWER LEVELING	18



WARNING

Read these safety rules and follow them closely. Failure to obey these rules could result in loss of control of vehicle, severe personal injury to yourself or bystanders, or damage to property or equipment affecting safety.

Safety Rules



This notation preceding Cautions and Warnings in the text signifies important precautionary steps which, if not properly followed, could result in personal injury or damage to your equipment affecting safety.

General

- Read the Operating and Service Instructions carefully. Be thoroughly familiar with the controls and the proper use of the equipment.
- Use only attachments and accessories designed for your machine. See your dealer for a complete list of approved attachments and accessories.
- Do not carry passengers.
- Keep the area of operation clear of all persons, particularly small children, and pets.
- When using attachments, never direct discharge of material toward bystanders nor allow any one near the vehicle while in operation.
- Make sure:
 - a. Unit is in good operating condition,
 - b. All safety devices and shields are in place and
 - c. All adjustments (cutting height, etc.) have been made.
- Never allow children to operate the machine. Do not allow adults to operate it without proper instruction.

Preparation

- Handle gasoline with care – it is highly flammable.
 - a. Use approved gasoline container.
 - b. Never remove the cap of the fuel tank or add gasoline to a running or hot engine, or fill the fuel tank indoors. Wipe up spilled gasoline.
- Do not run the engine indoors. Exhaust fumes are dangerous.
- Clear the work area of objects which might be picked up and thrown.
- Disengage attachment clutches and shift into neutral before attempting to start the engine.
- Wear heavy footwear. Do not operate unit when barefoot or when wearing open sandals or canvas shoes.

Operation

- Do not use third gear on slopes or hills.
- Stay alert for holes in the terrain and other hidden hazards. Be extra careful when operating on wet or slippery surfaces.
- Disengage power to attachment(s) when transporting or not in use.
- When using the vehicle with mower, proceed as follows:
 - a. Mow only in daylight or in good artificial light.
 - b. Check the blade mounting bolts for proper tightness at frequent intervals.
- Do not stop or start suddenly when going uphill or downhill. Mow up and down the face of slopes; never across the face.
- Reduce speed on slopes and in sharp turns to prevent tipping or loss of control. Use extreme caution when changing direction on slopes.
- Always lock brake pedals together when you intend to travel at higher speeds and before setting parking brake lock.
- Always depress both brake pedals equally and at the same time except when using a brake to make a sharper turn. Use this turning assist feature only at lower speeds.
- Watch out for traffic when crossing or near roadways.
- Disengage power to attachments and stop the engine before leaving the seat.
- Disengage power to attachments and stop the engine before making any repairs or adjustments.
- Be especially careful not to touch tractor or attachment parts which might be hot from operation. Allow such parts to cool before attempting to maintain, adjust or service.
- If equipment begins to vibrate abnormally — disengage power to attachments and stop engine at once. Inspect for damage and correct before starting up tractor.
- Use care when pulling loads or using heavy equipment.
 - a. Use only drawbar hitch point.
 - b. Limit loads to those you can safely control.
 - c. Do not turn sharply. Use care when backing.
 - d. Use counterweight(s) or wheel weights when suggested in the operator's manual.
- Take all possible precautions when leaving the vehicle unattended, such as disengaging the power take-off, lowering the attachment(s), shifting into neutral, setting the parking brake, stopping the engine, and removing the key.
- Keep the vehicle and attachments in good operating condition, and keep safety devices in place.

Maintenance and Storage

- Keep all nuts, bolts, and screws tight to be sure the equipment is in safe working condition.
- Do not change the engine governor settings or overspeed engine.
- To reduce fire hazard, keep the engine free of grass, leaves or excessive grease.
- Never store the equipment with gasoline in the tank inside a building where fumes may reach an open flame or spark. Allow the engine to cool before storing in any enclosure.

Identification

When ordering replacement parts for your rotary mower, be prepared to give your dealer the identification number found on the identification plate shown below. We suggest that you locate the number and record it below for easy reference.

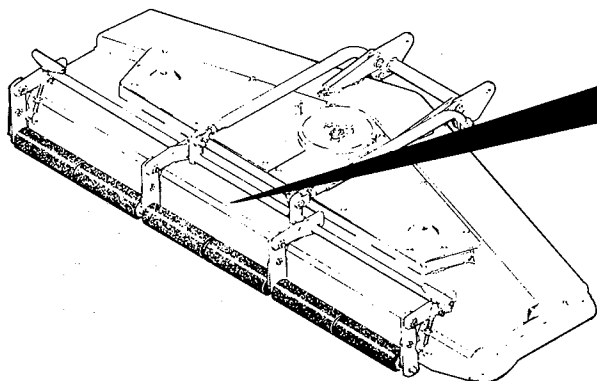

Refer to i.d. no. when writing or ordering parts.
I.D. No.

Specifications

DIMENSIONS	Effective Cutting Width	60 Inches (1.5 m)
	Overall Width	71 Inches (1.8 m)
	Overall Length	38 Inches (965 mm)
	Overall Height	11-1/2 Inches (292 mm)
	Cutting Height	Adjustable; Approximately 1-5/8 to 3 Inches (41 to 76 mm)
	Weight	282 Pounds (128 kg)
DRIVE	Input Drive	V-Belt from Electric Clutch on Tractor
	Side Blade Drive	V-Belt with Spring-Loaded Idler Pulley
	Center Blade Drive	Direct from Input Drive
	Blade Arrangement	Three Staggered Overlapping Blades
	Bearings	Needle Bearings with Grease Fittings
CONTROLS	Clutch	On Tractor; Operated by Electrical Switch
	Lift	On Tractor; Operated by Hydraulic Control Lever
	Height Adjustment	Twin Screws on Mower

Accessories and Attachments

There are optional accessories and attachments available for your tractor and rotary mower. See your dealer if you wish to purchase any of the following:

HITCH FOR MID-MOUNTED ATTACHMENTS – required to attach mower to tractor.

REAR WHEEL WEIGHTS – improves traction and stability for mowing of slopes.

HOURLY METER – records operating time so you can perform required care on schedule.

REAR HIGH FLOATION TIRES – offer better traction and allow sharper turns than turf tires.

FRONT BUMPER – needed to mount front weight.

FRONT WEIGHT – improves stability and steering on slopes.

REAR LIGHT KIT – illuminates work area for rear-mounted attachments.

Installation

CONTENT OF SECTION

Before it can be used, the rotary mower must be installed on your tractor. This section tells you how the rotary mower should be installed. It also tells you how to remove the mower from the tractor.

REQUIRED ACCESSORY

A hitch (item C, figure 1) for mid-mounted attachments is required to install the mower on the tractor. This item can be purchased from your dealer.

INSTALLATION

Install the rotary mower on your tractor as follows:

1. Install hitch (item C, figure 1) for mid-mounted attachments on your tractor. Use four pins (item A) and spring clips (item B) to secure hitch to brackets under front axle.

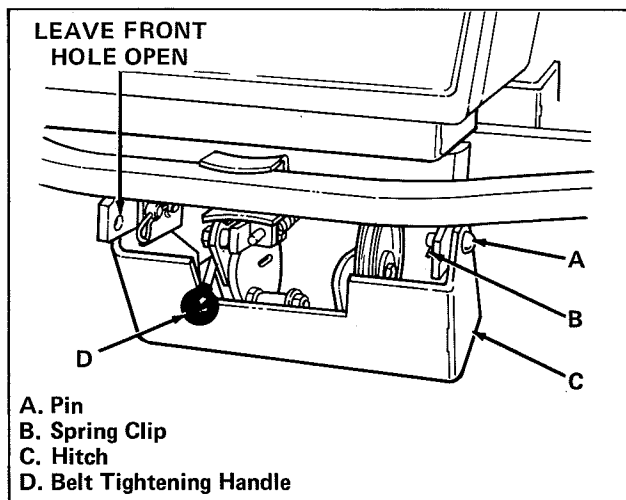

Figure 1. Install Hitch

2. Position mower under center of tractor. You can slide mower under tractor from either side after turning front wheels for a sharp turn. Or, you can drive the tractor up and over the mower as follows:
 - a. Place two planks (figure 2) on mower to serve as ramps. The planks must be slightly shorter than the distance between front and rear wheels of tractor.
 - b. Drive tractor up planks until front wheels are on mower.
 - c. Stop engine and set parking brake.
 - d. Remove planks.
 - e. Start tractor, release parking brake and drive forward until mower is centered between front and rear wheels.

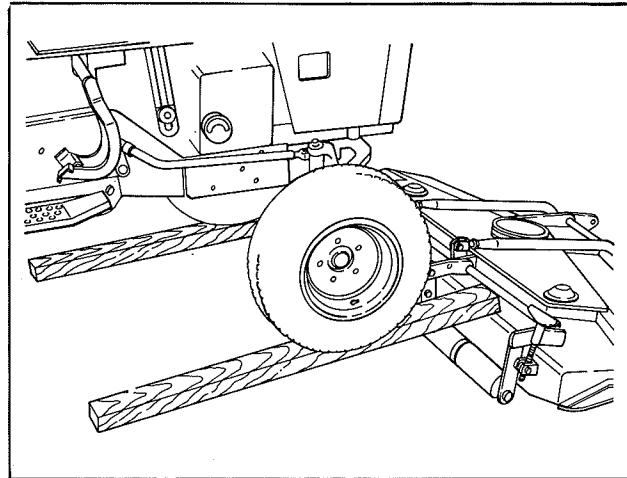

Figure 2. Drive Tractor Over Mower

3. Push rear lift control on tractor forward to fully lower rocker shaft (item D, figure 3).
4. Stop engine, remove ignition key, and set parking brake.
5. Remove spring clip (item C) and pin (item B) to detach left lift cable (item A) from tractor footrest.
6. Pull rear clevis (item E) of left lift cable rearward and attach it to rocker shaft (item D) using pin and spring clip removed in step 5.

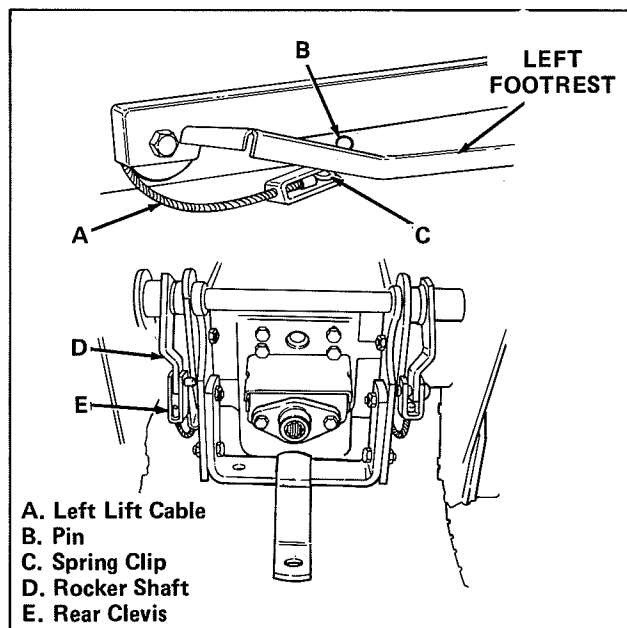

Figure 3. Attach Lift Cables to Rear Lift

7. Repeat steps 5 and 6 for right lift cable. Your tractor may have an extra long right lift cable. This cable is looped around the right rear axle for storage.
8. Attach front clevis (item B, figure 5) of left lift cable to eyebolt (item D) on mower. Use pin (item A) and spring clip (item C) supplied with mower.

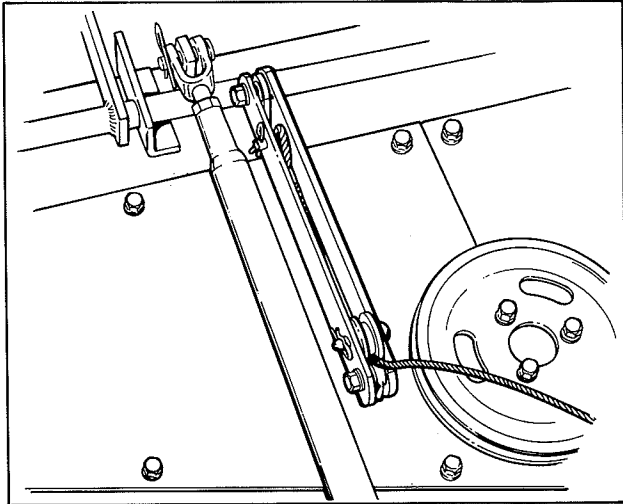

Figure 4. Attaching Bracket

9. Repeat step 8 to attach right lift cable to mower. If tractor has extra long right lift cable, brackets (see figure 4) supplied with lift cable must be attached to eyebolt and bracket on mower with capscrews and hex nuts. In this case, attach loop on end of cable to brackets near rear of mower. Use pin and spring clip supplied with mower. Then remove pin and spring clip that holds spacer to special brackets and reinstall these items with lift cable running under spacer.

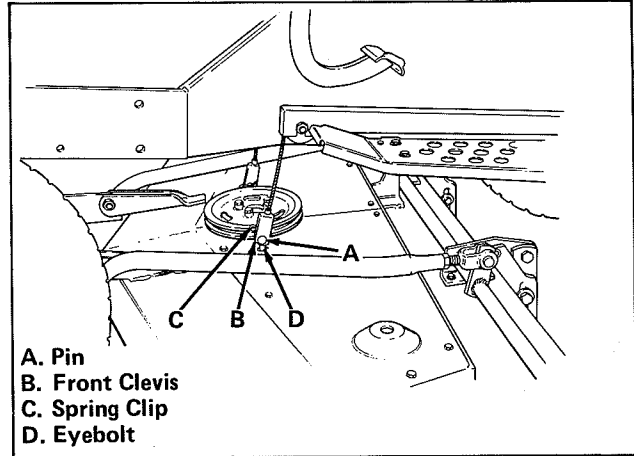

Figure 5. Attach Lift Cables to Mower

10. Start tractor engine. Use rear lift control on tractor to raise mower so holes in rocker arm (item D, figure 6) are in line with holes in hitch (item A). Then use two yoke pins (item B) and safety clips (item C) to attach rocker arm to hitch.

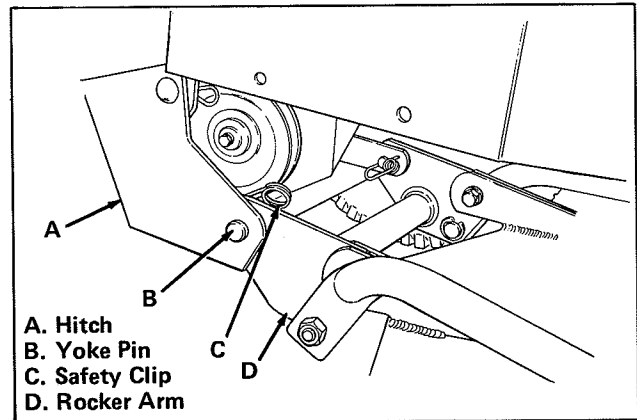

Figure 6. Attach Mower to Hitch

11. Stop tractor engine and raise hood. Be sure belt tightening handle (item D, figure 1) is pulled forward. Thread mower drive belt over front PTO pulley, hitch idler pulleys and mower pulley as shown in figure 7. Then return belt tightening handle to rearward position to tighten drive belt.

12. Complete adjustments described in Adjustment Section.

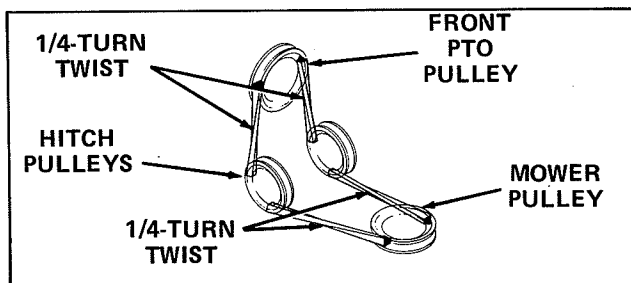

Figure 7. Install Mower Drive Belt

REMOVAL

1. Back rear wheels of tractor onto a pair of planks. (See figure 8.) Stop when mower rollers touch front of planks.

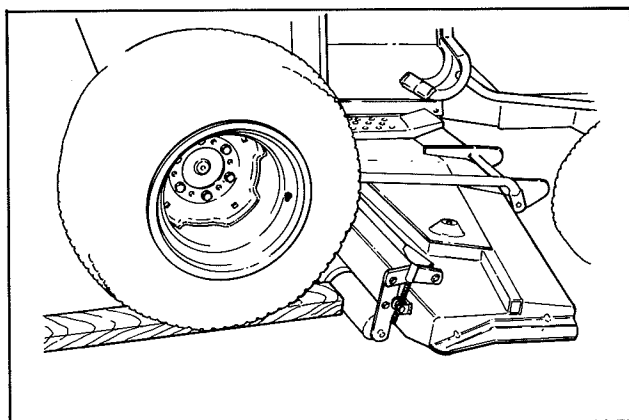

Figure 8. Setup Planks for Mower Removal

2. Stop engine, remove ignition key, and set parking brake.

3. Pull belt tightening handle (item D, figure 1) fully forward. Then remove mower drive belt from tractor PTO pulley, front hitch idler pulleys, and mower pulley.

4. Start tractor engine. Use rear lift control to raise mower to a point where yoke pins (item B, figure 6) are loose. Then stop engine and remove ignition key.

5. Remove safety clips (item C) and yoke pins (item B). Lower mower to ground by pushing rear lift control forward to its float position. Then reinstall yoke pins and safety clips in holes of rocker arm (item D).

6. Remove spring clips (item C, figure 5) and pins (item A) to detach lift cables from mower. Install pins and spring clips on mower to prevent loss.

7. Remove spring clips and pins to detach rear clevis (item E, figure 3) of both lift cables from rocker shaft (item D).

8. Pull left lift cable (item A) forward and attach front clevis to footrest using pin and spring clip removed in step 7. Do the same on the right side if tractor is equipped with normal right lift cable. If right lift cable is extra long, loop it around right rear axle before re-installing the pin and spring clip.

9. Drive tractor backwards over mower.

10. If desired, remove spring clips (item B, figure 1) and pins (item A) to detach hitch for mid-mounted attachments from tractor.

Operation

CONTENT OF SECTION

A brief description of the rotary mower controls, followed by the basic operating procedures, is given in this section to help you get to know your rotary mower and how to operate it safely and efficiently.

ROTARY MOWER CONTROLS

The rotary mower is operated using controls on the tractor. Figure 9 shows the locations, names and functions of these controls. The control names given in figure 9 are used throughout the manual.

OPERATING PROCEDURES

The rest of this section tells you how to operate your rotary mower. The directions assume that both the rotary mower and tractor work properly. If not, refer to the troubleshooting sections of this manual and the tractor manual.

WARNING

Before attempting to inspect, adjust, or service the rotary mower make sure the **FRONT CLUTCH** switch is off, the engine is stopped, ignition key removed, and parking brake is set.

CHECKS BEFORE STARTING

The checks listed below should be performed before each use of the rotary mower.

1. Read this manual. Read the tractor operator's manual. Be sure you know safety precautions and locations and uses of operating controls.
2. Check the rotary mower to insure that it is properly installed on tractor. Be sure that all safety guards are in place and that all nuts, bolts and spring clips are secure.
3. Refer to Normal Care section of this manual to determine and perform any needed care for the rotary mower. Do the same for the tractor.
4. Clear the area you intend to work in to be sure that it is free of all items that may be caught in or thrown by the rotary mower.

TRACTOR AND MOWER OPERATION

The tractor supplies both the power and forward motion for the rotary mower. Therefore, tractor operation is vital to proper rotary mower operation. Details for rotary mower operation are given in paragraphs that follow. Read all of these paragraphs. Then read the general operating procedure for tractor operation with attachments given in the tractor manual before attempting to use the rotary mower.

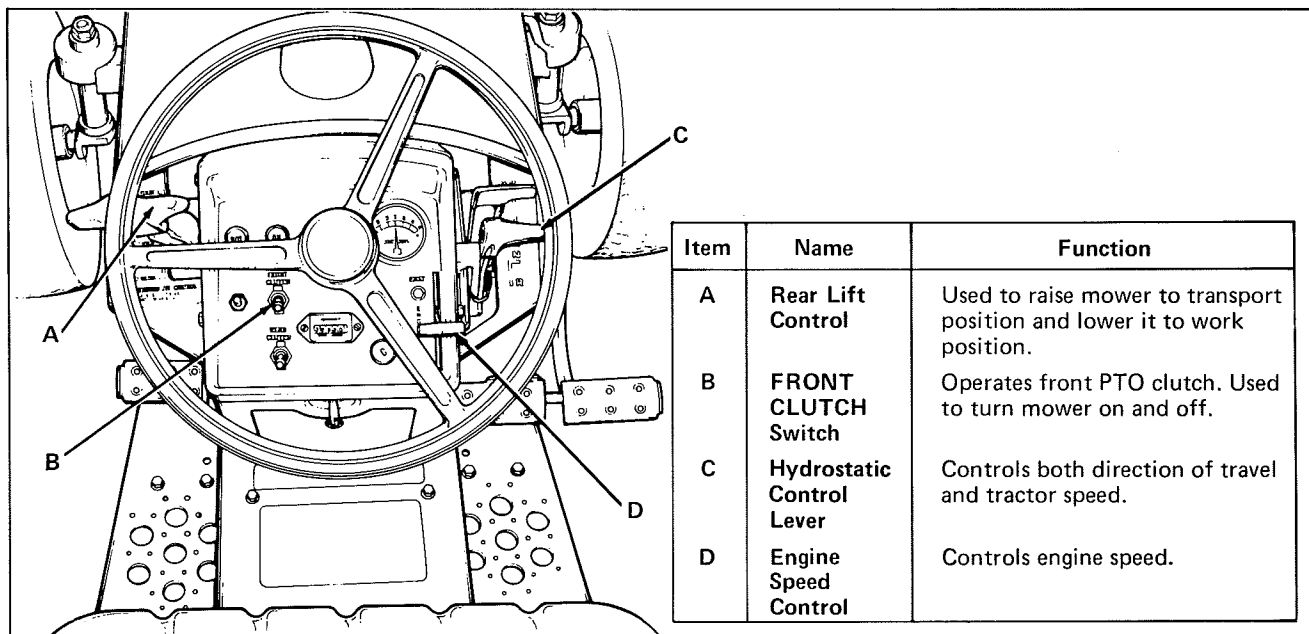

Figure 9. Locations and Functions of Controls

Stopping the Rotary Mower

To stop the rotary mower blades during operation, push the FRONT CLUTCH switch down to its off position. Always stop the rotary mower before raising it and before leaving the tractor seat.

Raising and Lowering the Rotary Mower

Use the rear lift control (item A, figure 9) to raise and lower the rotary mower. After insuring that the mower is stopped, pull the rear lift control rearward to raise the mower. Release the control and allow it to return to its center hold position to keep the mower raised. To lower the mower to its work position, push the rear lift control forward to lower the mower until the lift cables are loose. Then release the control so it can return to its center hold position.

Transporting the Rotary Mower

When you use the tractor to transport the rotary mower to and from work areas, stop the mower and then raise it fully. Use a combination of gear shift lever, engine speed control, and hydrostatic control lever settings to produce the desired travel speed. Be sure to adjust the settings as you travel to fit the surface conditions.

Cutting Height

The exact cutting height will depend upon the type and condition of your lawn and your own personal desires. Most lawns should be mowed to keep the grass approximately 2 to 3 inches (51 to 76 mm) high. Best results are obtained by mowing grass often and not too short. To keep a green lawn, never mow more than 1/3 of the height or more than 1 inch (25 mm) off the grass in a single mowing.

For extremely tall grass, adjust for maximum cutting height for the first mowing. Then readjust for the desired height and mow again.

On thick or springy grass or soft ground, the mower roller may sink into the lawn. In this case, it will be necessary to readjust the cutting height to keep the grass at the same height.

WARNING

Do not work around mower housing area until you are certain that engine has stopped and the mower blades have stopped rotating.

The cutting height is changed by turning the two cutting height handles (figure 10) equal amounts in the same direction. Turn these handles clockwise for higher cutting; turn handles counterclockwise for lower cutting.

NOTE

Do not use the tractor lift system to raise and lower the mower for height adjustments. Early belt failures and poor cutting will result from this practice.

If you want to adjust for a specific cutting height, make the adjustment on a hard, level surface. Turn the blades so they point straight forward and backward. Then measure the distance between the surface and the rear tip of one blade.

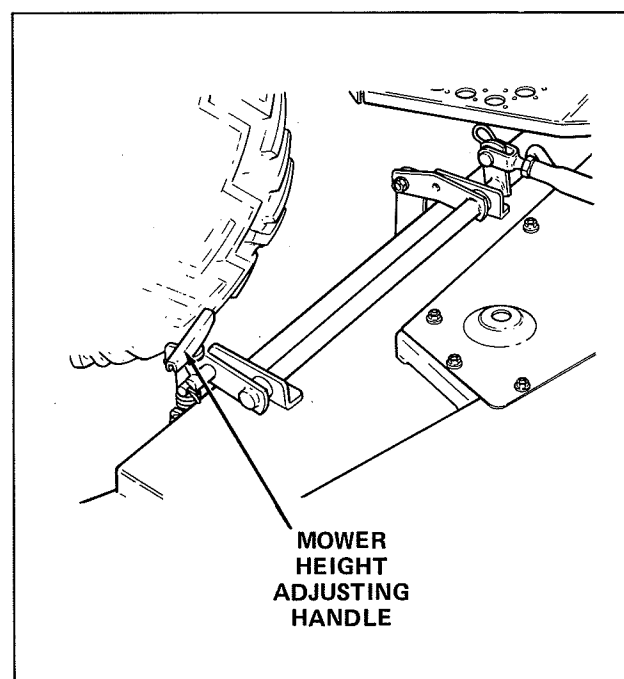

Figure 10. Adjust Cutting Height

Engine Speed

The engine speed control on the tractor should be set for 2/3 to full speed when mowing. When the grass is wet or over 2 inches (50 mm) high, the engine should be run at full speed for best results. However, avoid cutting wet grass when possible. If possible, cut the grass in the afternoon or evening when the moisture content is the lowest. This practice will minimize build-up of grass under the mower housing and clogging of the discharge.

Tractor Speed

All forward speeds of the tractor may be useful for mowing under some conditions. Higher speeds should be used only on smooth, level lawns with light to moderate grass crops. Always select a speed slow enough to assure safe control of the tractor and a smooth, even cutting of the grass.

Mowing Patterns

Plan your mowing patterns to fit the area to be mowed. In most cases, one or two passes should be made around the area in a clockwise direction to keep the left side of the mower close to trees, shrubs, fences, and buildings as shown in figure 11. This practice will eliminate most of your hand trimming and keep the cut grass off fences, buildings, and sidewalks.

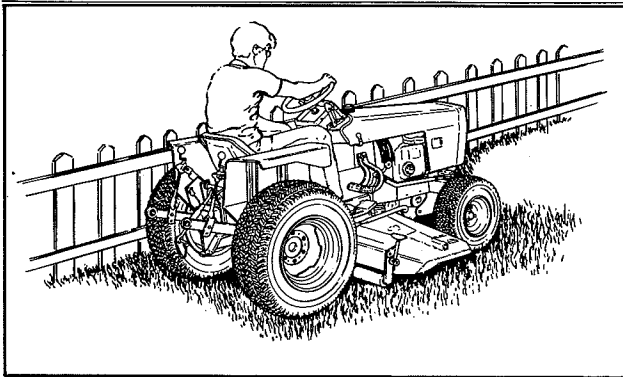

Figure 11. Mow with Left Side Near Obstructions

Normally, the remainder of the area should be cut in a counterclockwise direction as shown in figure 12. This will prevent recutting of the grass and spread it evenly over your lawn. The clippings, when decayed, make an excellent organic fertilizer.

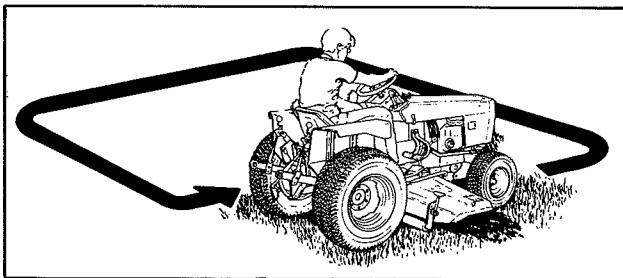

Figure 12. Mow in a Counterclockwise Direction

On frequently mowed lawns or when the grass is dry and light, it may be practical to mow in a clockwise direction. This practice will throw clippings toward the center of the lawn where they can be easily gathered and removed.

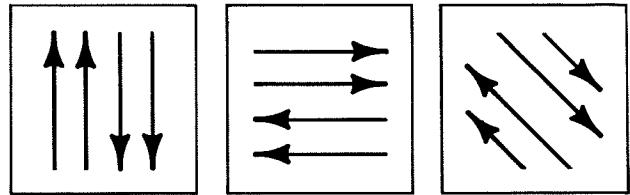

Figure 13. Change Mowing Patterns

Where possible, change the general mowing pattern for each cutting. (See figure 13 for mowing pattern diagrams.) Changing patterns will prevent matting of the lawn that causes an uneven appearance.

On slopes, you cannot vary mowing patterns. Always mow up and down the face of slopes; never across the face. On slopes over 20 percent (11.3 degrees), use two rear wheel weights. Do not mow on slopes greater than 35 percent (19.3 degrees).

Starting Mower

To start the mower into operation, proceed as follows:

1. Lower rotary mower to its work position so lift cables are loose.
2. Set engine speed control for desired mowing speed.
3. Select transmission gear best suited to grass and surface conditions.

WARNING

Insure that mower discharge is not pointed toward nearby persons or buildings. Also insure that people, especially small children, and pets remain clear of tractor and mower.

4. Push FRONT CLUTCH switch on tractor forward to its on position to start mower blades.

WARNING

If mower or tractor begins to vibrate abnormally or if you strike a foreign object, stop the mower immediately. Also stop the engine, remove the ignition key and set the parking brake. Then check the tractor and mower and correct the cause of the vibration before starting again.

5. Start tractor into motion. Use hydrostatic control lever to adjust tractor speed to grass and ground conditions.

Normal Care

CONTENT OF SECTION

Your mower was designed and built to provide years of service with only minor care. Certain tasks, however, must be performed to keep the mower in good operating condition and to avoid costly repairs. This section describes and provides procedures for the necessary care of the mower.

SCHEDULED CARE

A schedule for routine care of the mower is provided in figure 14. Some of the scheduled requirements are based on operating hours. For this reason, it will be necessary to determine or estimate total operating time. This is easily accomplished if your tractor is equipped with an hour-meter. If not, you can determine normal times for regular mowing jobs. Multiply these normal times by the number of times you perform these jobs

and add any unusual operating time to estimate the total operating time.

A maintenance record (figure 18) is provided at the rear of this section. Use this record to document all operating hours, repair and service for the mower.

STORAGE

To protect your mower, store it in an enclosed, dry area. To prepare the mower for off-season storage, perform the following:

1. Remove mower from tractor. (Refer to procedure in Installation Section.)
2. Clean underside of mower to remove all grass and dirt.
3. Coat all bare metal surfaces with paint or a light coat of oil to prevent rusting.
4. Lubricate the mower. (See figure 15.)
5. Check, sharpen, and balance the mower blades. (See figure 16.)

Care Required	See Figure	Schedule			
		Before Each Use	After Each Use	Every 25 Hours	Yearly
Check to be sure all screws, nuts, bolts, and pins are present and secure.	None	•			
Clean underside of mower to remove grass and dirt accumulations.	None		•		
Lubricate mower arbors and pivot points.	15			•*	
Clean/sharpen blades.	16				•**
Lubricate idler pulley pivot.	17				•

*At least once a year.
**More often under heavy use and immediately after striking any hard object.

Figure 14. Summary of Scheduled Care

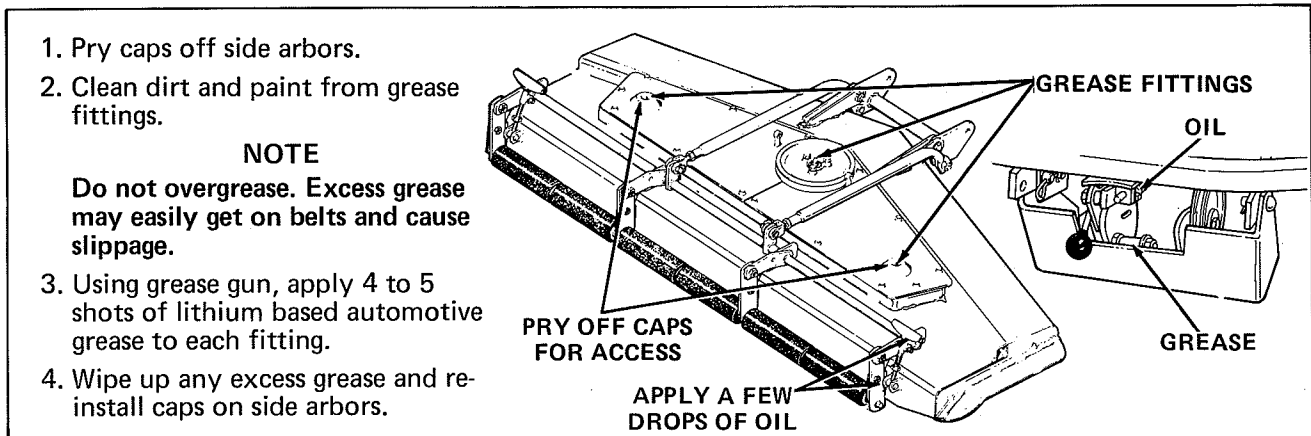

Figure 15. Lubricate Mower Arbors and Pivot Points

1. Remove mower from tractor.
(Refer to removal procedure in Installation Section.)
2. Check each of the three blades. Blades should be sharp and free of nicks and dents. If not, sharpen blades as described in remaining steps.

⚠ WARNING

Do not handle mower blades with bare hands. Careless or improper handling may result in serious injury.

3. To remove blade for sharpening, use wooden block to hold blade while removing its blade mounting capscrews.
4. Use a file to sharpen blade to fine edge. Remove all nicks and dents in blade edge. If blade is severely damaged, it should be replaced.
5. Check and balance blade. Use a balancing machine or the fixture shown. File material off heavier end of blade until it is balanced.

⚠ WARNING

Blade mounting capscrews must be installed with lockwashers and securely tightened. Torque blade mounting capscrews to 45 foot-pounds (61 N·m).

6. Install blade on arbor with tabs pointing up toward deck and secure with capscrews and lockwashers. Use wooden block to prevent blade rotation while installing and tightening blade mounting capscrews.

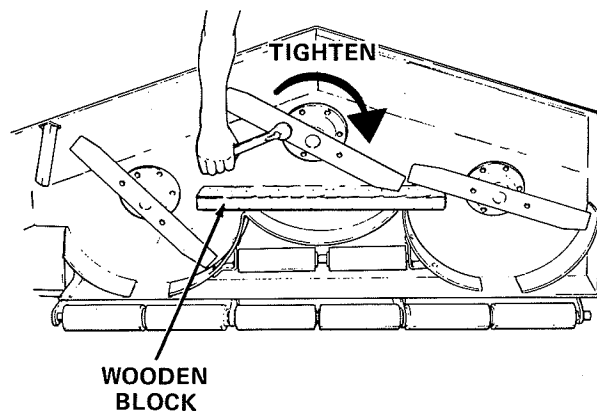
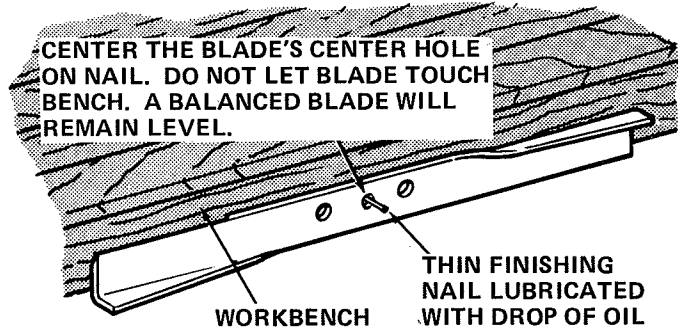
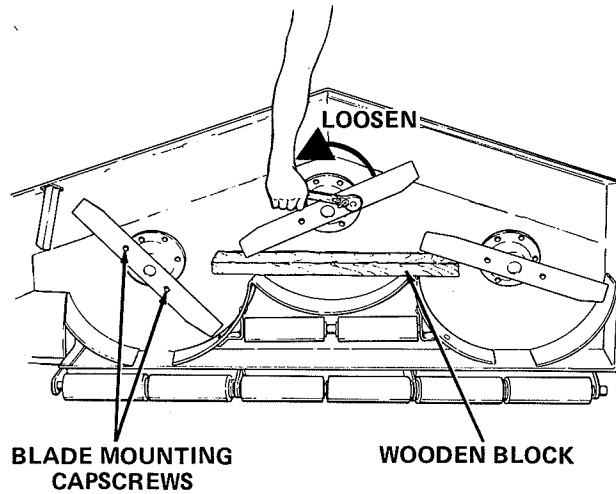

Figure 16. Check, Sharpen, and Balance Mower Blades (Yearly Care)

1. Remove capscrews and lockwashers to detach drive pulley.
2. Remove spring clip and pin to detach left bail from rear of mower.
3. Remove washer-head screws that secure left cover. Then remove cover.
4. Apply a few drops of engine oil to idler pulley pivot.
5. Install and secure cover.
6. Attach left bail to rear of mower using pin and spring clip removed in step 2.
7. Install drive pulley and capscrews with lockwashers. Tighten capscrews to 20 foot-pounds (27 N·m) of torque.

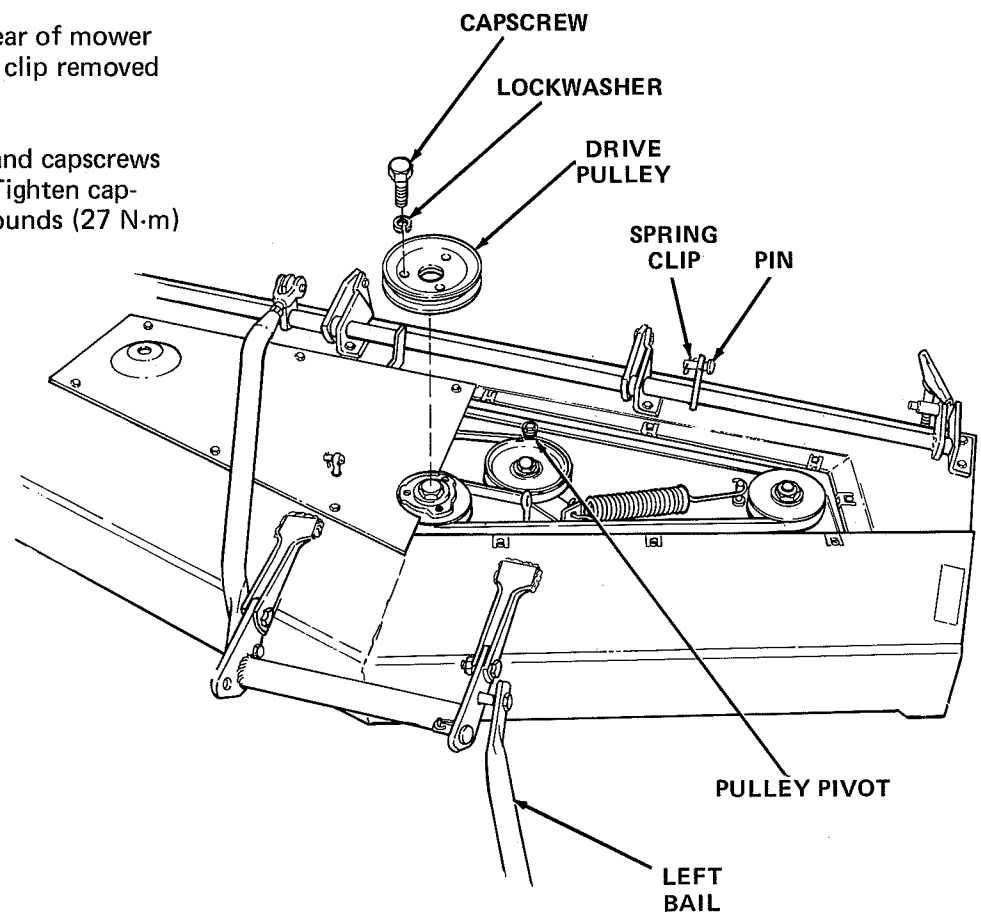

Figure 17. Lubricate Idler Pulley Pivot (Yearly Care)

Troubleshooting

CONTENT OF SECTION

This section of the manual provides troubleshooting and repair instructions for the more common and easily corrected problems.

WARNING

To avoid serious injury, perform maintenance on the mower only after stopping the tractor engine and waiting for the mower blades to come to a complete stop. Always remove the ignition

key before beginning the maintenance to prevent accidental starting of the engine.

TROUBLESHOOTING PROCEDURES

Troubleshooting procedures are provided in figure 19. To use these procedures, first locate the problem description that best describes the trouble that you have encountered. Check the possible causes one at a time in the order that they are listed. Correct any problems that are found and operate the mower again to verify that you have eliminated the trouble.

Problem	Cause/Remedy
1. Mower will not raise or raises unevenly.	A. Lift cable not attached or broken. B. Hydraulic lift problem. See tractor manual.
2. Mower cut is uneven.	A. Mower not leveled properly. Repeat leveling adjustment. B. Tractor tires not inflated equally or properly. C. Missing pin on mower hitch.
3. Mower cut is rough looking.	A. Engine speed too slow. B. Tractor speed too fast. C. Blades dull and require sharpening. D. Mower drive belt oily or worn. Clean or replace belt as necessary. E. Deck drive idler pulley pivot frozen; needs lubrication. F. Deck drive belt worn or broken; replace.
4. Engine stalls easily with mower engaged.	A. Tractor speed too fast. B. Engine speed too slow. C. Cutting height set too low when mowing tall grass. Cut tall grass at maximum cutting height during first pass. D. Discharge chute jamming with cut grass; cut grass with discharge pointing toward previously cut area.
5. Excessive mower vibration.	A. Blade mounting screws are loose; tighten to 45 foot-pounds (61 N·m) of torque. B. Mower blades are bent and should be replaced. C. Mower blades are out of balance; remove, sharpen, and balance blades. (See figure 16). D. Arbor shaft bent due to impact; check shaft for wobble.
6. Excessive belt breakage occurs.	A. Loose or rough pulleys require replacement. B. Using incorrect belt. C. Pulley misaligned or shaft is bent. D. Belt not properly tensioned. See Adjustments Section.

Figure 19. Troubleshooting Procedures

V-BELT REPLACEMENT

To replace the V-belt between the tractor PTO pulley and the mower; follow the mower removal and installation instructions provided in the Installation Section of this manual.

To replace the internal V-belt of the mower, proceed as follows:

1. Remove three capscrews (item A, figure 20) with lockwashers and detach drive pulley (item B) from mower.
2. Remove spring clips (item D) and pins (item E) and swing bails (item H) forward.
3. Remove washer head screws (item I) and lift both covers (item J) clear of mower.

CAUTION

Remove and install spring with care. Spring is under tension and can snap back.

4. Remove spring (item G).
5. Remove the old V-belt (item F).
6. Lubricate idler pulley pivot (item C) with a few drops of engine oil. Wipe up any excess oil.
7. Clean interior of the belt housing. Also be sure that pulley grooves are clean and smooth.
8. Install new V-belt. Then install spring (item G).
9. Install both covers (item J). Secure covers by installing and tightening washer-head screws (item I).
10. Attach bails (item H) to brackets at rear of mower using pins (item E) and spring clips (item D).
11. Install drive pulley (item B). Then install lockwashers and capscrews (item A). Tighten capscrews to 20 foot-pounds (27 N-m) of torque.

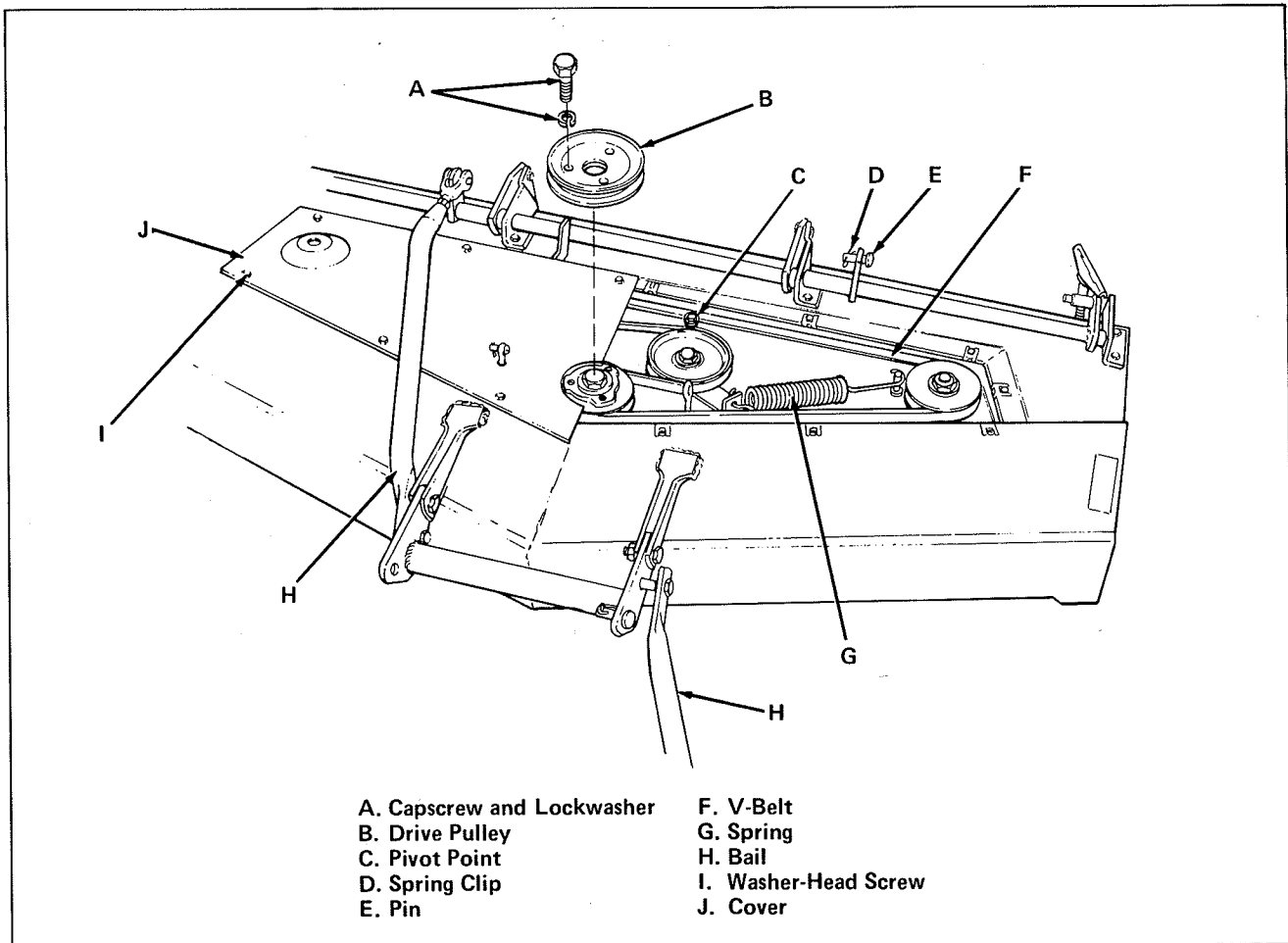

Figure 20. V-Belt Replacement

Adjustments

CONTENT OF SECTION

This section tells you how to adjust the rotary mower to keep it operating efficiently. Normally, the adjustment procedures should be performed after installation and thereafter only to correct problems.

WARNING

To avoid serious injury, perform adjustment procedures only when the tractor engine is stopped. Always remove the ignition key before beginning the adjustment procedures to prevent accidental starting of the engine.

ADJUSTMENT PROCEDURES

Belt Tension

To check the belt tension, push the belt tightening lever (item D, figure 21) fully rearward. Then measure the gap between set collar (item A) and bracket (item B). The gap should be 1/2 to 5/8 inch (13 to 16 mm). If not, adjust belt tension as follows:

1. Pull belt tightening handle (item D) fully forward.
2. Hold rod (item C) steady while loosening setscrew in set collar (item A).

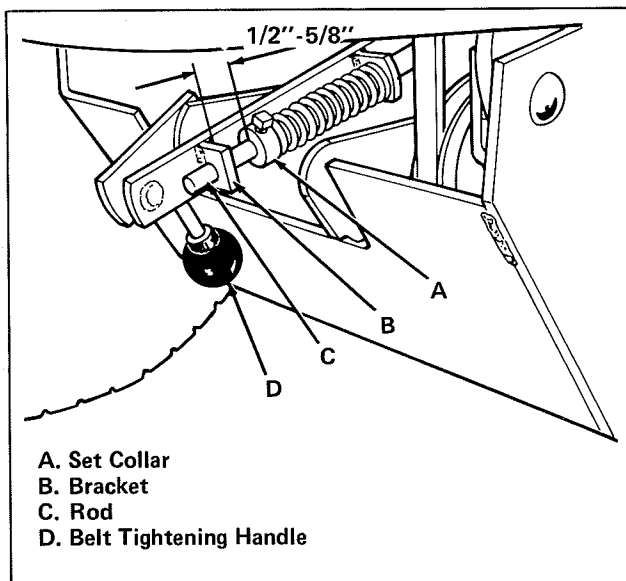

Figure 21. Belt Tension Adjustment

3. Pull rod (item C) slightly forward to increase gap; push rod slightly rearward to decrease gap.
4. Hold rod at new position while tightening setscrew in set collar.
5. Repeat check and, if needed, adjustment until gap is correct.
6. Check belt clearance. (See next paragraph.)

Belt Clearance

When the mower is installed and the V-belt is properly tensioned, check the clearance between both belt strands and the edges of the frame slot below the tractor front PTO pulley. To prevent rubbing and wear, the clearance must be at least 1/4 inch (6 mm) at all four points. If not, adjust the clearance as follows:

1. Pull belt tightening handle (item D, figure 22) fully forward.
2. Loosen nut (item C) and slide pulley (item A) in slot (item B) to adjust clearance. Sliding this pulley toward rear of tractor will move belt strand on same side of tractor away from the battery toward the engine. At the same time, the belt strand from the tension pulley (item E) will move in the opposite direction.
3. Tighten nut (item C) to 50 foot-pounds (67 N-m) of torque to hold pulley at new position.
4. Push belt tightening handle (item D) fully rearward. Repeat clearance check and, if needed, adjustment.
5. Check and, if needed, readjust belt tension.

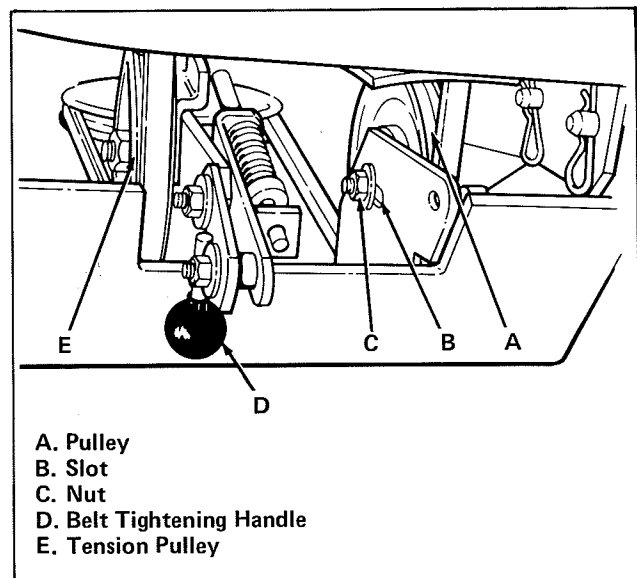

Figure 22. Belt Clearance Adjustment

Mower Leveling

When the mower is properly leveled, the tips of the blades are slightly higher at the front of the mower than at the rear. To check the leveling, park the tractor and mower on a hard, level surface. Turn off the tractor engine and lower the mower until the lift cables are loose. Rotate the blades so the blade tips are at the front and back of the mower. Then turn height adjusting handles (item A, figure 23) until rear tips (item G) of both side blades are 2 inches (50 mm) above ground. At this point, front tip (item F) of center blade should be 2-1/4 inches (56 mm) above ground. If not, relevel mower as follows:

1. Using hydraulic lift system, raise mower slightly so its rear rollers are just off ground.
2. Loosen jam nut (item D) on both sides of mower.
3. Remove pin and spring clip (item B) to detach both yokes (item C) from mower.
4. Turn both yokes (item C) equal amounts in same direction. To increase height at front of mower, turn both yokes further into adjusting arms (item E). Turn the yokes further out of adjusting arms to decrease front height.
5. Reattach both yokes (item C) to mower using pins and spring clips (item B).
6. Lower mower to ground and repeat check and, if needed, adjustment.
7. When mower is properly leveled, tighten both jam nuts (item D) firmly against adjusting arms (item E).

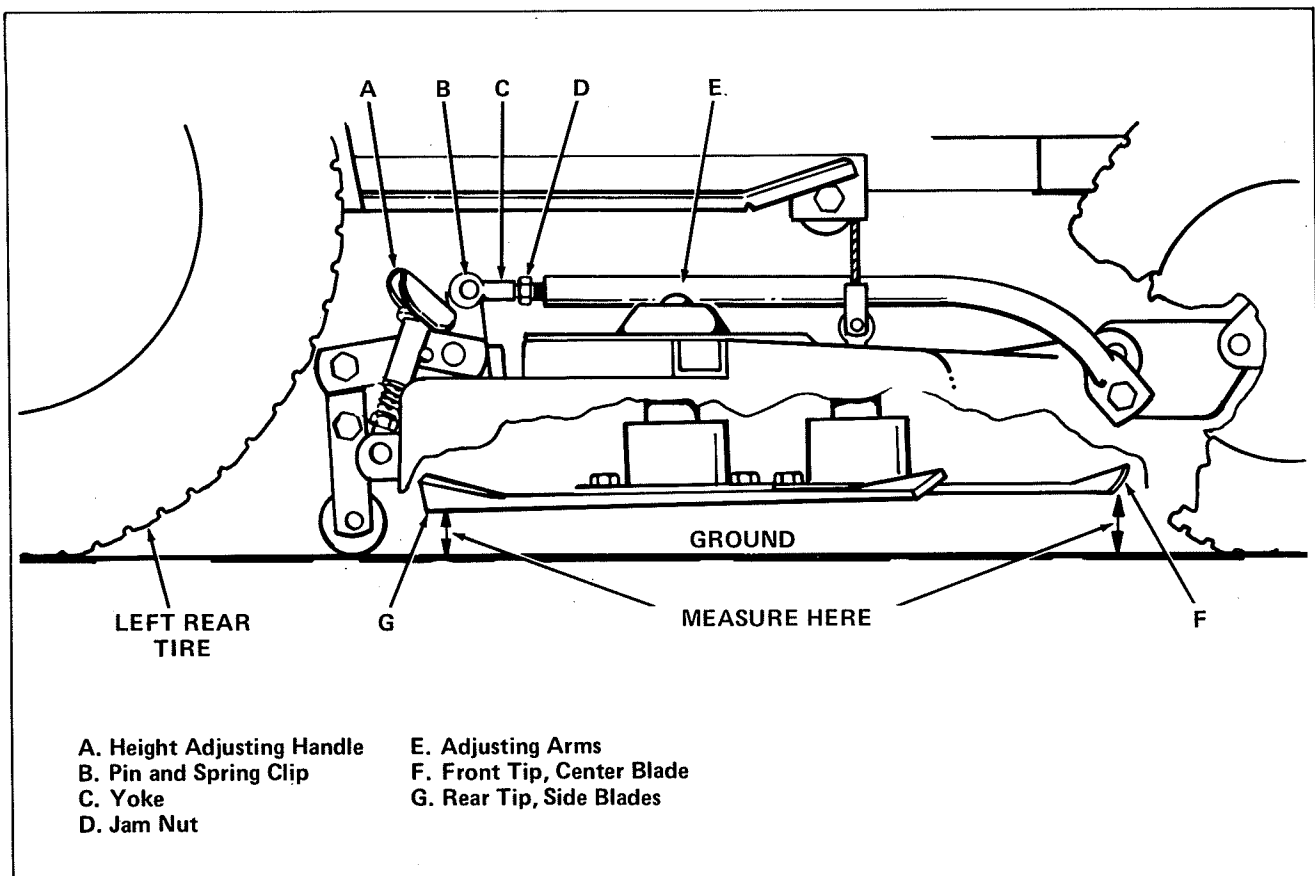

Figure 23. Mower Leveling Adjustment





