

# Concerning Compact Discs

Only compact discs bearing this mark can be used with this unit.

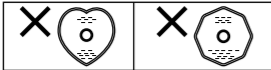

However, continued use of irregular shape CDs (heart-shape, octagonal, etc.) can damage the unit.  
CD-R and CD-RW discs recorded with the audio CD format can be played back, though some may not be played back because of the disc characteristics or recording condition.



The Non-DVD side of a "DualDisc" does not comply with the "Compact Disc Digital Audio" standard. Therefore, the use of Non-DVD side of a DualDisc on this product may not be recommended.

## How to hold a disc

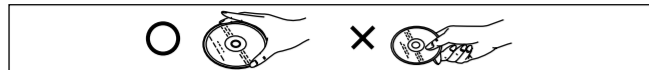

## If the disk surface is dirty

Wipe it with a damp cloth and then wipe dry. Wipe from the center toward the outer edge.

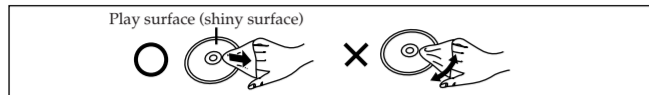

## If moisture has formed on a disc

When moisture has formed because the disc was brought suddenly into a warm room from a cold environment, wipe off the moisture using a soft dry cloth.

## When storing discs

- Avoid locations which are
- Exposed to direct sunlight.
- Susceptible to high levels of humidity or dust.
- Directly exposed to heat from a heating appliance.
- On top of a car dashboard or near the rear window.

## Handling precautions

- On the label side (the side with writing) Do not write anything using a pencil, ball-point pen, etc. Do not use adhesive paper or labels.
- Do not attach labels or stickers to CDs.
- On the disc (shiny) side Handle this side carefully to keep it free from fingerprints or scratches. Do not use record cleaners, solvents, etc.
- Do not use CDs with exposed adhesive from tape or left over peeled off stickers.
- Do not use scratch-proof protectors or covers other than those specified for use with this unit.



# PORTABLE CD PLAYER XL-PM6S/XL-PR70B

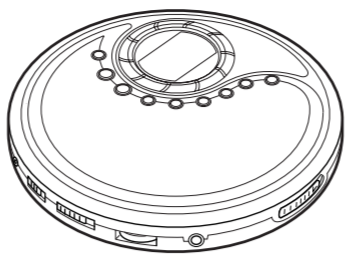

MP3/WMA\*  
PLAYBACK

## INSTRUCTIONS

\* Only XL-PR70B supports WMA

## Supplied Accessories

Stereo headphones ..... 1 pc.

Thank you for purchasing this JVC product. Please read these instructions carefully before starting operation to be sure to obtain optimum performance and a longer service life from the unit.

LVT1297-004A [B]  
©2005 Victor Company of Japan, Limited

# Power Supply Preparations

## Using dry-cell batteries (not supplied)

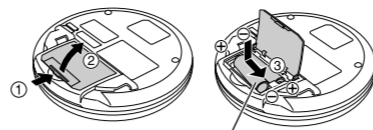

**Caution:** Two "LR6" alkaline batteries.

Do not forcibly open the battery lid too wide.

## Battery indicator

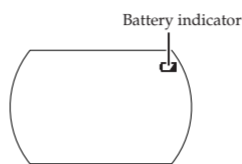

This indicator appears when the batteries are almost out of power. Power will be cut off a short while later.

## Note:

Turning off the Anti-Shock Protection EX will save the battery power more or less. For details, see "Anti-shock Protection EX" on page 7. (Available for an Audio CD only)

## Using the AC adaptor (not supplied)

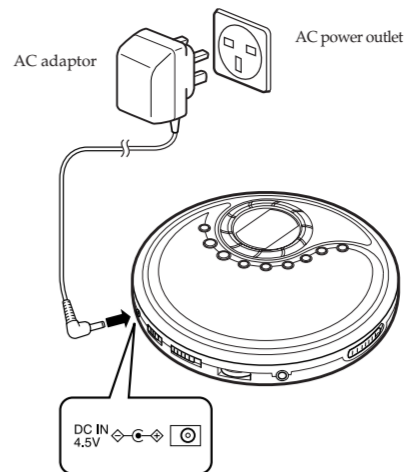

## Notes:

- Even if the unit is turned off, small power is consumed as long as the AC adaptor is connected to the AC power outlet.
- When you want to purchase the AC adaptor, see page 4.

# Specifications

## Portable CD player

- Type : Compact disc player
- Signal detection system : Non-contact optical pickup (semiconductor laser)
- Pickup system : 3 beam laser
- Number of channels : 2 channels (stereo)
- Frequency response : 20 Hz to 20 kHz
- Wow & flutter : Unmeasurable
- Output : Headphones (3.5 mm dia. stereo × 1)  
9 mW/ch at 10% THD/16 Ω matching impedance (16 Ω to 1 kΩ)
- FM tuning range (XL-PR70B only) : 87.50 MHz - 108.00 MHz
- Duration of battery (with Anti-Shock Protection EX OFF) : Approx. 20 hours when using two alkaline batteries (LR6)
- Power requirements : DC 3 V ( "LR6" size battery × 2)  
DC 2.4V (rechargeable battery × 2)  
DC IN 4.5 V
- Dimensions (W×H×D) : 138 mm × 26 mm × 138 mm (Excluding buttons and controls)
- Mass : XL-PM6S 240 g  
XL-PR70B 250 g (without batteries)

## AC adaptor (not supplied)

- Input power source : AC 230V, 50 Hz
- Output voltage : DC 4.5 V, 600 mA

- Design and specifications are subject to change without notice.
- Microsoft and Windows Media are either registered trademarks or trademarks of Microsoft Corporation in the United States and/or other countries.

# Maintenance

## Unit

- Wipe the unit with a soft cloth. Remove stubborn dirt using a cloth which has been dipped in water or soapy water and wrung out, and then wipe dry.
- If you intend to use a chemically treated cleaning cloth, read its directions first.
- Do not use alcohol or paint thinners.

## Lens

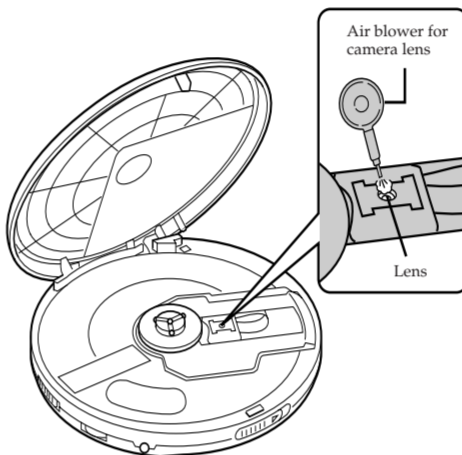

# Precautions

## Safety

- Care of AC adaptor** - The cord of the AC adaptor should be routed so that they are not likely to be walked on or pinched by items placed upon or against them. Never take hold of the AC adaptor if your hand is wet, and always grasp the plug when connecting or disconnecting it.
- Disconnect when not in use** - When not in use, be sure to disconnect the AC adaptor from the AC power outlet.
- Batteries** - If the unit is not used for a long period of time or is used only from an AC power source, remove all the batteries to prevent potential damage due to battery leakage. Do not mix (old and new ) batteries or different types of batteries.

## Installation

### Environment

- Condensation** - Moisture may form on the lens in the following conditions.
  - immediately after a heater has been turned on.
  - in a steamy or very humid room.
  - when the unit is suddenly moved from a cold environment to a warm one. If moisture forms inside this unit, it may not operate properly. To correct this problem wait about one hour for the moisture to evaporate.

### Placement

- Foreign Material** - Care should be taken so that objects do not fall into and liquids are not spilled into the unit. Do not subject this unit to excessive smoke, dust, mechanical vibration, or shock.
- Magnetism** - The unit should be situated away from equipment or devices that generate strong magnetic fields.
- Stacking** - Do not place any objects on top of the unit.

## Maintenance

(See page 2 for details.)  
Clean the cabinet, panel and controls with a soft cloth lightly moistened with mild detergent solution. Do not use any type of abrasive pad, scouring powder or solvent such as alcohol or benzine.

## Service

- Damage Requiring Service** - The unit should be serviced by qualified service personnel when:
  - (a) The AC adaptor is damaged; or
  - (b) Objects have fallen or liquid has been spilled into the unit; or
  - (c) The unit has been exposed to rain; or
  - (d) The unit does not appear to operate normally or exhibits a marked change in performance; or
  - (e) The unit has been dropped, or the enclosure damaged.

## WARNING:

TO REDUCE THE RISK OF FIRE OR ELECTRIC SHOCK, DO NOT EXPOSE THIS APPLIANCE TO RAIN OR MOISTURE.

## CAUTION!

THIS PRODUCT UTILIZES A LASER. USE OF CONTROLS OR ADJUSTMENTS OR PERFORMANCE OF PROCEDURES OTHER THAN THOSE SPECIFIED HEREIN MAY RESULT IN HAZARDOUS RADIATION EXPOSURE. DO NOT OPEN COVERS AND DO NOT REPAIR YOURSELF. REFER SERVICING TO QUALIFIED PERSONNEL.

## CAUTION:

- Do not block the ventilation opening or holes. (If the ventilation openings of holes are blocked by a newspaper or cloth, etc., the heat may not be able to get out.)
- Do not place any naked flame sources, such as lighted candles, on the apparatus.
- When discarding batteries, environmental problems must be considered and local rules or laws governing the disposal of these batteries must be followed strictly.
- Do not expose this apparatus to rain, moisture, dripping or splashing and that no objects filled with liquids, such as vases, shall be placed on the apparatus.

## IMPORTANT FOR LASER PRODUCTS

- CLASS 1 LASER PRODUCT**
- CAUTION:** Do not open the top cover. There are no user serviceable parts inside the unit; leave all servicing to qualified service personnel.
- CAUTION:** Visible and invisible laser radiation when open and interlock failed or defeated. Avoid direct exposure to beam.
- REPRODUCTION OF LABEL: CAUTION LABEL, PLACED OUTSIDE THE UNIT.**

<b>CAUTION:</b> Visible and invisible laser radiation when open and interlock failed or defeated. AVOID DIRECT EXPOSURE TO BEAM. (e)	<b>WARNING:</b> Synlig Och osynlig laserstrålning när den öppnas och spårren är urkopplad. Beträkta ej strålen. (s)
<b>ADVARESEL:</b> Synlig og usynlig laserstrålning når maskinen er åben eller interlocken fejle. Undgå direkte eksponering til stråling. (d)	<b>VARO:</b> Avattaessa ja Suogalukitus ohitettunatai viiallisena olet alttina näkyväille ja näkymättömälle lasersäteilylle. Vältä säteen kohdistumista suoraan itseesi. (f)

# Cautions

## Listening precautions

- Do not play your headphones at a high volume. Hearing experts advise against continuous extended play.
- If you experience a ringing in your ears, reduce volume or discontinue use.
- Do not use while operating a motorized vehicle. It may create a traffic hazard and is illegal in many areas.
- You should use extreme caution or temporarily discontinue use in potentially hazardous situations.
- Even if your headphones is an open-air type designed to let you hear outside sounds, don't turn up the volume so high that you can't hear what's around you.

## Rechargeable batteries

- Rechargeable batteries (not supplied) can be used.
- To use the rechargeable batteries, follow the instruction manual attached to the rechargeable batteries and charger (not supplied).

## Dry cell batteries

- To prevent damage to the batteries and electrolyte leakage, heed the following points.
- Align the ⊕ and ⊖ polarities properly when inserting the batteries.
- Do not mix different types or makers of batteries or old and new batteries.
- Remove the batteries if you do not plan to use the unit for a long period of time.
- Do not throw batteries into a fire, and do not short-circuit, disassemble or subject them to excessive heat.
- Do not attempt to recharge dry cell batteries.

## Carrying dry cell batteries around

When putting dry cell batteries in a pocket or bag, ensure that no other metal objects such as a necklace are placed together with them. Contact with metal may cause short-circuiting which, in turn, may cause a fire.

## AC adaptor

- Handle the AC adaptor carefully. Improper handling is dangerous.
  - Do not touch it with wet hands.
  - Do not place heavy objects on top of it.
  - Do not forcibly bend it.
- Be sure to connect only the specified AC adaptor with the unit.
- Disconnect the AC adaptor from the power outlet if the unit is not going to be used for a long time.

# Troubleshooting

Problem	Check this
<b>Poor tuner reception</b>	• Extend the headphone cord (antenna) to improve reception.
<b>Does not turn on.</b>	• Is the AC adaptor securely connected? • Is the HOLD switch set to OFF position?
<b>Cannot close the lid.</b>	Is the disc properly secured in place?
<b>Cannot play discs.</b>	• Is the disc properly secured in place? • Is there moisture condensation on the lens? (Wait for about an hour and then try again.) • Are MP3/WMA files recorded on the disc? • Do MP3/WMA files have the extension code—.mp3 or .wma? • Are MP3/WMA files recorded in the format compliant with ISO 9660?
<b>Cannot hear music—too noisy.</b>	• Is the headphone plug inserted all the way? • Is the plug dirty? (Wipe away dirt on the plug.) • Are you playing a compatible disc? While playing a non-MP3/WMA file, you will hear a noise. (Note: It may not be an MP3/WMA file although it has the extension code—.mp3 or .wma)
<b>TV picture is distorted. Other radio reception is noisy.</b>	Are you using the unit too near a TV or tuner? (If the TV or tuner is connected to a simple indoor antenna, connect it to an outdoor antenna.)
<b>"DISC" or "Er" is displayed when a disc is in the player.</b>	• Is the disc damaged? • Is the disc playable on this player? • Has the disc been inserted upside down?

If the remedies indicated in the chart do not solve the problem, refer to the directory of Authorized Service Centers (enclosed with this unit) to locate a convenient service center, or consult your dealer for instructions.

# Basic Play

WMA can be played back only with XL-PR70B.

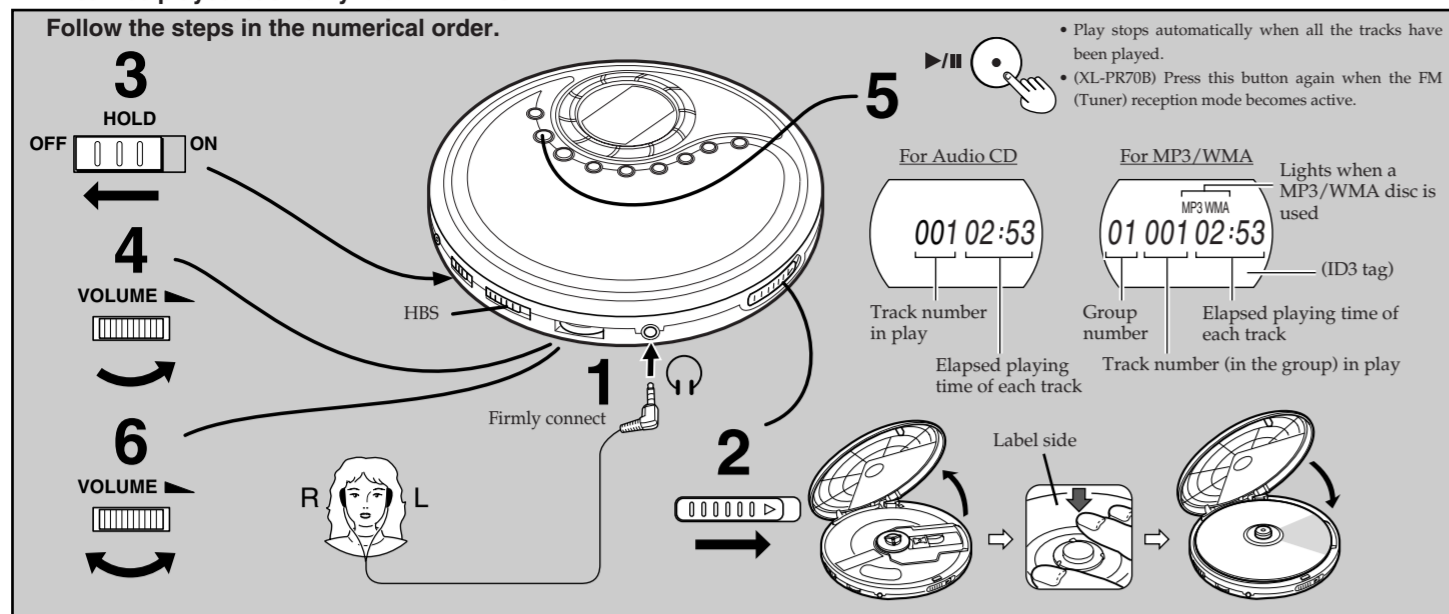

Operation	Button	Display/reference	
		Audio CD	MP3/WMA
To pause	▶/II	007 00:18-	01 004 00:07-
To stop	■	010 44:48 Total playing time	10 035 Total number of tracks
To turn off the unit	■	No indication	
Fast forward/ reverse	Skip function During play, Reverse	<ul style="list-style-type: none"> <li>To skip back to the previous track, quickly press ◀ twice.</li> <li>During Program play, the button is used to fast forward or back through the programmed sequence of tracks.</li> <li>During Random play, the skip button cannot be used to skip back to tracks that were played previously in the random sequence.</li> </ul>	
	Forward		
Group skip (MP3/WMA only)	Search function Keep depressed during play.		
	GROUP UP, GROUP DOWN	Group number 02 001	
(XL-PR70B only) To switch over the mode from FM to CD	FM, ▶/II	In FM mode,	

**For your reference:**  
**"DISC"**  
 This indication appears if ▶/II is pressed when no disc is loaded or if the disc is not properly seated.

**"READING"**  
 Preparation period before playing the track. Appears for several seconds after pressing ▶/II to play.

**"OPEN"**  
 This indication appears when the lid is open.

**Removing discs**  
 Turn off the unit and, after the disc has stopped rotating, remove the disc as shown below:



**Auto power off**  
 If the unit is left in stop mode for 30 seconds, the unit turns itself off automatically to prevent the batteries from running down. Auto power off function does not work when the source is FM.

**Disc rotation noise**  
 The portable CD player uses a power-saving operation method so that disc rotation noise will intermittently be emitted. But, it is not a failure.

# About MP3/WMA files

## MP3/WMA File Compatibility

- This player can read MP3/WMA files that are recorded in the format that is compliant with ISO 9660.
- The player can read or play an MP3 file with the extension code ".mp3" and a WMA file with the extension code ".wma".
- Track title can be displayed.
- ID3 tags can be shown on the display.
- An MP3/WMA file can contain file information called "ID3 Tag" where its album name, artist, title, etc. are recorded.

## Playing order of MP3/WMA files

The illustration below shows the normal playing order of the MP3/WMA files. You will see that the MP3/WMA files are played back in the order from the higher hierarchy to the lower one.

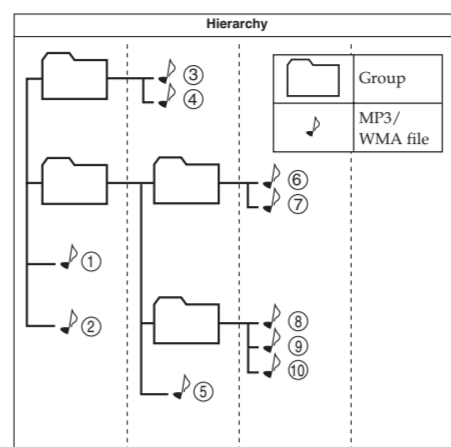

# Other Play Methods

**Intro play**  
 You can successively play the first 10 seconds of every track.

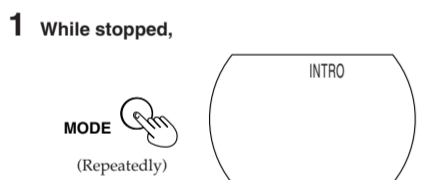

**To cancel**  
 Press MODE repeatedly until "INTRO" goes out.

**Notes:**

- You can also select Intro play during playback.
- In this case, Intro play will start from the next track after the current track has finished.
- You can also select Intro play during Program play mode.

**Random play**  
 During playback, press MODE repeatedly.

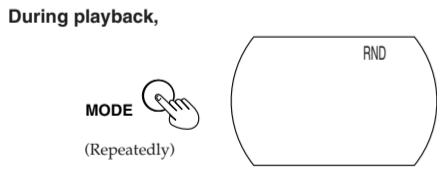

**To cancel**  
 Press MODE until "RND" goes out, or press ■ to stop the disc.

**Notes:**

- You can also select Random play in stop mode.
- During Program play, you can not select Random play.

**Repeat play**  
 You can repeat one track or all tracks.

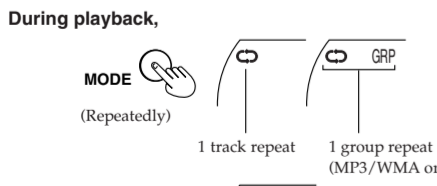

**To cancel**  
 Press MODE repeatedly until the repeat indicator goes out.

**Notes:**

- You can also select Repeat play during Program play.
- You can also select Repeat play while stopped.

**Notes:**

- You can also select Repeat play during Program play.
- You can also select Repeat play while stopped.

**To confirm the program**  
 While stopped, press PROGRAM repeatedly. At this time, you can add and change the program, if required.

**To delete the entire program**

- While stopped, press STOP.
- Turn off the unit.
- (XL-PR70B) Change the source to FM.

**Notes:**

- Before turning on the unit, be sure that HOLD is OFF. Otherwise, you cannot turn on the unit.

# Tuner Operation (XL-PR70B only)

You can listen to FM stations by tuning in manually, automatically, or using preset memory. For best reception, extend the headphone cord (antenna).

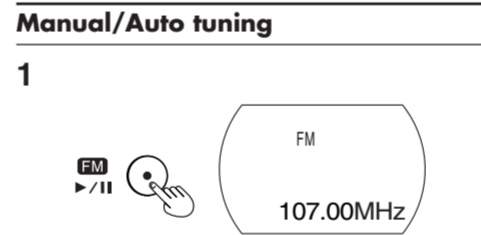

**Manual tuning**  
 Press ▶/II or ◀ repeatedly to select a station you want.

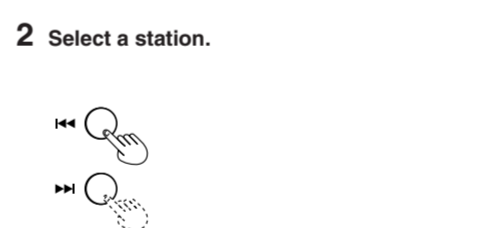

**Auto tuning**  
 Hold down ▶/II or ◀ for a while and then release it. The frequency automatically changes up or down to find the next station.

## Presetting stations

You can preset up to 20 stations (frequencies). Use Manual or Auto tuning mentioned earlier.

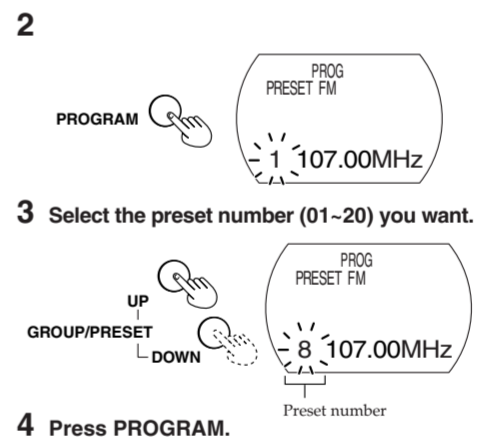

## Preset tuning

Select the preset number you want in the FM reception mode.

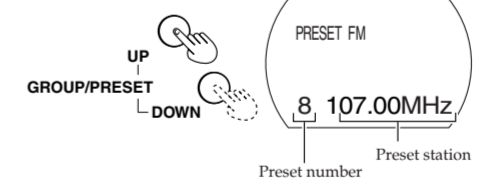

## Changing the FM reception mode

When a broadcast is in stereo, "ST." lights up and you can hear stereo effects. However, if an FM stereo broadcast is hard to receive or noisy, you can select monaural (MONO) mode. Reception improves, but you lose the stereo effect.

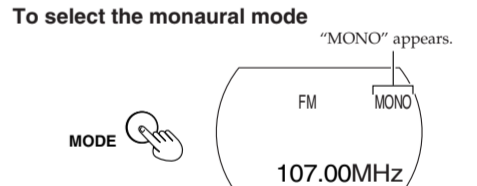

**To cancel the monaural mode**  
 Press MODE once again. "MONO" will go out. The monaural mode is cancelled also by changing the frequency.

## Turning off the unit

