

# Operating Instructions

Mini DV<sup>NTSC</sup>

Digital Video Camera Recorder

Model AG-**DVX100**P

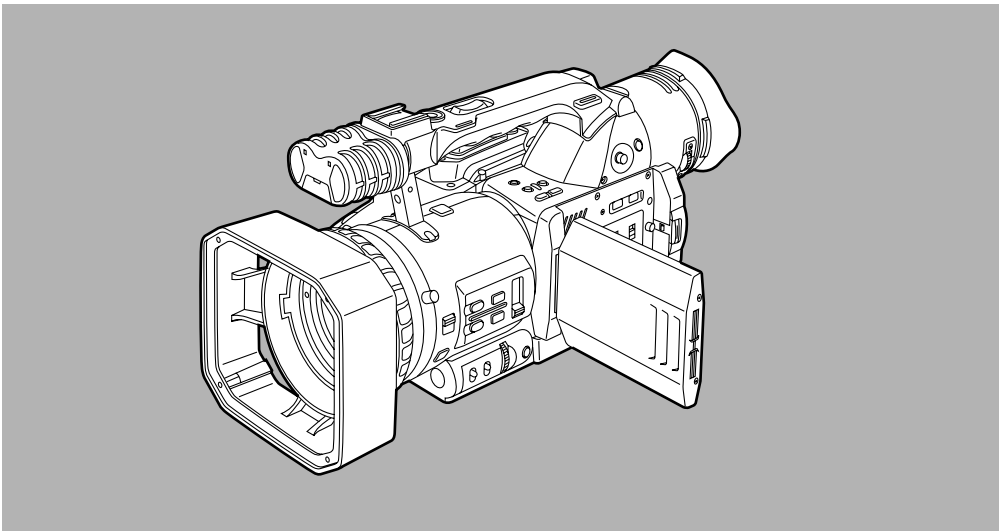

**Panasonic**<sup>®</sup>

Before operating this product, please read the instructions carefully and save this manual for future use.





Printed in Japan  
F0802W3112 [D]

VQT0A97-3

## IMPORTANT

“Unauthorized recording of copyrighted television programs, video tapes and other materials may infringe the right of copyright owners and be contrary to copyright laws.”

	<b>CAUTION</b> RISK OF ELECTRIC SHOCK DO NOT OPEN	
<b>CAUTION: TO REDUCE THE RISK OF ELECTRIC SHOCK, DO NOT REMOVE COVER (OR BACK). NO USER SERVICEABLE PARTS INSIDE. REFER TO SERVICING TO QUALIFIED SERVICE PERSONNEL.</b>		



The lightning flash with arrowhead symbol, within an equilateral triangle, is intended to alert the user to the presence of uninsulated “dangerous voltage” within the product’s enclosure that may be of sufficient magnitude to constitute a risk of electric shock to persons.



The exclamation point within an equilateral triangle is intended to alert the user to the presence of important operating and maintenance (service) instructions in the literature accompanying the appliance.

### WARNING:

**TO REDUCE THE RISK OF FIRE OR SHOCK HAZARD, DO NOT EXPOSE THIS EQUIPMENT TO RAIN OR MOISTURE.**

**TO REDUCE THE RISK OF FIRE OR SHOCK HAZARD, KEEP THIS EQUIPMENT AWAY FROM ALL LIQUIDS-USE AND STORE ONLY IN LOCATIONS WHICH ARE NOT EXPOSED TO THE RISK OF DRIPPING OR SPLASHING LIQUIDS, AND DO NOT PLACE ANY LIQUID CONTAINERS ON TOP OF THE EQUIPMENT.**

### CAUTION:

**TO REDUCE THE RISK OF FIRE OR SHOCK HAZARD AND ANNOYING INTERFERENCE, USE THE RECOMMENDED ACCESSORIES ONLY.**

### CAUTION:

**Do not install or place this unit in a bookcase, built-in cabinet or any other confined space in order to maintain adequate ventilation. Ensure that curtains and any other materials do not obstruct the ventilation to prevent risk of electric shock or fire hazard due to overheating.**

### FCC Note:

This device complies with Part 15 of the FCC Rules. To assure continued compliance follow the attached installation instructions and do not make any unauthorized modifications.

This equipment has been tested and found to comply with the limits for a class A digital device, pursuant to Part 15 of the FCC Rules. These limits are designed to provide reasonable protection against harmful interference when the equipment is operated in a commercial environment. This equipment generates, uses, and can radiate radio frequency energy and, if not installed and used in accordance with the instruction manual, may cause harmful interference to radio communications. Operation of this equipment in a residential area is likely to cause harmful interference in which case the user will be required to correct the interference at his own expense.

### CAUTION:

Danger of explosion or fire if battery is mistreated.

- Replace only with same or specified type.
- Do not disassemble or dispose of in fire.
- Do not store in temperatures over 60°C.
- Use specified charger for rechargeable batteries.
- Do not recharge the battery if it is not a rechargeable type.

### For Remote Controller

- Replace battery with part No. CR2025 only.
- Do not recharge the battery.

 indicates safety information.

# Important Safeguards

---

1. Read Instructions — All the safety and operating instructions should be read before the unit is operated.
2. Retain Instructions — The safety and operating instructions should be retained for future reference.
3. Heed Warnings — All warnings on the unit and in the operating instructions should be adhered to.
4. Follow Instructions — All operating and maintenance instructions should be followed.
5. Cleaning — Unplug this video unit from the wall outlet before cleaning. Do not use liquid or aerosol cleaners. Use a dry cloth for cleaning.
6. Attachments — Do not use attachments not recommended by the video product manufacturer as they may be hazardous.
7. Water and Moisture — Do not use this video unit near water — for example near a bath tub, wash bowl, kitchen sink, or laundry tub, in a wet basement, or near a swimming pool, and the like.
8. Accessories — Do not place this video unit on an unstable cart, stand, tripod, bracket, or table. The video unit may fall, causing serious injury to a child or adult, and serious damage to the unit. Use only with a cart, stand, tripod, bracket, or table recommended by the manufacturer, or sold with the video unit. Any mounting of the unit should follow the manufacturer's instructions and should use a mounting accessory recommended by the manufacturer.  
An appliance and cart combination should be moved with care. Quick stops, excessive force, and uneven surfaces may cause the appliance and cart combination to overturn.
9. Ventilation — Slots and openings in the cabinet are provided for ventilation and to ensure reliable operation of the video unit and to protect it from overheating. These openings must not be blocked or covered. Never place the video unit on a bed, sofa, rug, or other similar surface, or near or over a radiator or heat register. This video unit should not be placed in a built-in installation such as a bookcase or rack unless proper ventilation is provided or the manufacturer's instructions have been adhered to.
10. Power Sources — This video unit should be operated only from the type of power source indicated on the marking label. If you are not sure of the type of power supply to your home, consult your appliance dealer or local power company. For video units intended to be operated from battery power, or other sources, refer to the operating instructions.
11. Grounding or Polarization — This video unit may be equipped with either a polarized 2-wire AC (Alternating Current) line plug (a plug having one blade wider than the other) or 3-wire grounding type plug, a plug having a third (grounding) pin.  
The 2-wire polarized plug will fit into the power outlet only one way. This is a safety feature. If you are unable to insert the plug fully into the outlet, try reversing the plug. If the plug still fails to fit, contact your electrician to replace your obsolete outlet. Do not defeat the safety purpose of the polarized plug.  
The 3-wire grounding type plug will fit into a grounding type power outlet. This is a safety feature. If you are unable to insert the plug into the outlet, contact your electrician to replace your obsolete outlet. Do not defeat the safety purpose of the grounding type plug.
12. Power-Cord Protection — Power-supply cords should be routed so that they are not likely to be walked on or pinched by items placed upon or against them, paying particular attention to cords of plugs, convenience receptacles, and the point where they exit from the unit.



# Important Safeguards

13. Outdoor Antenna Grounding — If an outside antenna or cable system is connected to the video unit, be sure the antenna or cable system is grounded so as to provide some protection against voltage surges and built-up static charges. Part 1 of the Canadian Electrical Code, in USA Section 810 of the National Electrical Code, provides information with respect to proper grounding of the mast and supporting structure, grounding of the lead-in wire to an antenna discharge unit, size of grounding conductors, location of antenna discharge unit, connection to grounding electrodes, and requirements for the grounding electrode.

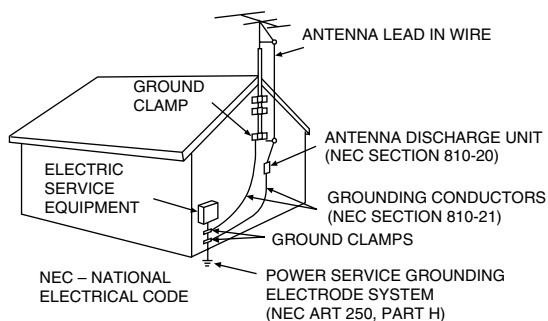

14. Lightning — For added protection of this video unit receiver during a lightning storm, or when it is left unattended and unused for long periods of time, unplug it from the wall outlet and disconnect the antenna or cable system. This will prevent damage to the video unit due to lightning and power-line surges.

15. Power Lines — An outside antenna system should not be located in the vicinity of overhead power lines or other electric light or power circuits, or where it can fall into such power lines or circuits. When installing an outside antenna system, extreme care should be taken to keep from touching such power lines or circuits as contact with them might be fatal.

16. Overloading — Do not overload wall outlets and extension cords as this can result in a risk of fire or electric shock.

17. Objects and Liquids — Never push objects of any kind into this video unit through openings as they may touch dangerous voltage points or short out parts that could result in a fire or electric shock. Never spill liquid of any kind onto the video unit.

18. Servicing — Do not attempt to service this video unit yourself as opening or removing covers may expose you to dangerous voltage or other hazards. Refer all servicing to qualified service personnel.

19. Damage Requiring Service — Unplug this video unit from the wall outlet and refer servicing to qualified service personnel under the following conditions:

- When the power-supply cord or plug is damaged.
- If any liquid has been spilled onto, or objects have fallen into the video unit.
- If the video unit has been exposed to rain or water.
- If the video unit does not operate normally by following the operating instructions. Adjust only those controls that are covered by the operating instructions, as an improper adjustment of other controls may result in damage and will often require extensive work by a qualified technician to restore the video unit to its normal operation.
- If the video unit has been dropped or the cabinet has been damaged.
- When the video unit exhibits a distinct change in performance – this indicates a need for service.

20. Replacement Parts — When replacement parts are required, be sure the service technician has used replacement parts specified by the manufacturer or have the same characteristics as the original part. Unauthorized substitutions may result in fire, electric shock or other hazards.

21. Safety Check — Upon completion of any service or repairs to this video unit, ask the service technician to perform safety checks to determine that the video unit is in safe operating order.

**FCC Warning:** Any unauthorized changes or modifications to this equipment would void the user's authority to operate.

# Contents

<b>Accessories</b> .....	6	<b>Screen displays</b> .....	47
<b>Precautions for use</b> .....	7	Camera mode and VCR mode .....	47
<b>Storage tips</b> .....	9	VCR mode .....	52
<b>Parts and their functions</b> .....	10	Selecting the display .....	53
<b>Remote control unit</b> .....	20	<b>Connecting external components</b> .....	54
<b>Charging the battery</b> .....	21	<b>Shooting</b> .....	55
<b>Mounting the battery</b> .....	22	Preparation and inspections .....	55
<b>Supplying power from the AC adapter</b> .....	22	Regular shooting .....	55
<b>Cassette tapes</b> .....	23	REC check .....	55
<b>Adjusting the hand strap</b> .....	24	Face-to-face shooting .....	56
<b>Attaching the shoulder strap</b> .....	24	Index recording .....	56
<b>Mounting the lens hood</b> .....	24	Using the USER buttons .....	56
<b>Viewfinders</b> .....	25	Intermittent recording .....	56
<b>Setting the calendar</b> .....	27	Backup recording .....	57
<b>Charging the internal battery</b> .....	28	Progressive shooting .....	58
<b>Setting the electronic shutter</b> .....	29	<b>Playback</b> .....	59
<b>White balance and black balance</b> .....	30	Normal playback .....	59
Adjusting the white balance .....	30	Tape blank search .....	59
Adjusting the black balance .....	31	Variable speed search .....	59
ATW (Auto Tracking White) function .....	31	Index search .....	59
<b>Setting the time data</b> .....	32	<b>Condensation</b> .....	60
Setting the user's bit .....	32	<b>Video heads</b> .....	60
Setting the time code .....	33	<b>Troubleshooting (Q&amp;A)</b> .....	61
<b>Scene files</b> .....	34	Power supply-related problems .....	61
Changing the scene file settings .....	35	Battery-related problems .....	61
<b>Setting menus</b> .....	37	Problems during normal video recording .....	61
Operation method .....	37	Problems during various kinds of video recording .....	62
Configuration of setting menus .....	38	Editing-related problems .....	62
SCENE FILE screen .....	39	Display-related problems .....	62
CAMERA SETUP screen .....	40	Playback-related problems (video) .....	62
SW MODE screen .....	40	Playback-related problems (audio) .....	63
AUTO SW screen .....	41	Other types of problems .....	63
PLAYBACK FUNCTIONS screen .....	42	<b>Maintenance</b> .....	64
RECORDING SETUP screen .....	43	<b>Specifications</b> .....	65
AV IN/OUT SETUP screen .....	44		
DISPLAY SETUP screen .....	45		
OTHER FUNCTIONS screen .....	46		

- “LEICA” is the registered trademark of Leica Microsystems.
  - “DICOMAR” is the registered trademark of Leica Camera AG.
- Other model names, company names, products names, etc. are the trademarks and registered trademarks of the companies concerned.

# Accessories

- Battery (\*)

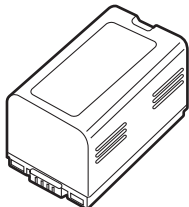

- AC adapter (\*)

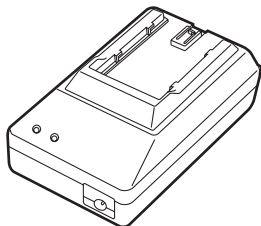

- AC cable (K2CB2DB00001)

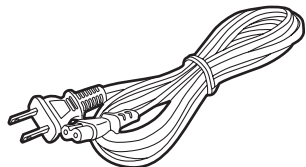

- DC cable (VEK8722)

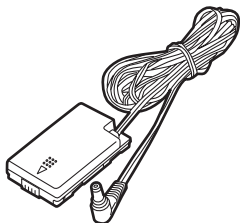

- Wireless remote control unit (N2QAEC000003)

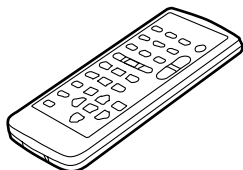

- Battery for remote control unit (CR2025)



- Eye cup (VMG1458)

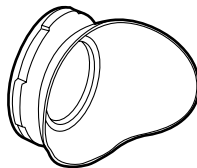

- Microphone holder (VYC0870)

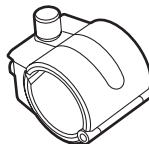

- Screws



- Microphone holder adapter (VYC0890)



- Shoulder strap (VFC3891)

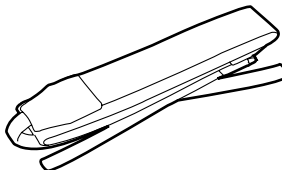

- Cleaning tape (AY-DVMCL)

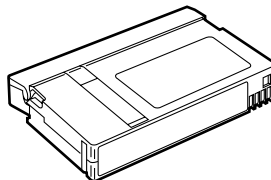

\* :

Refer to the "OPTIONAL ACCESSORIES" item (on page 66) for the model numbers of the battery and AC adapter.

# Precautions for use

---

**Take care to prevent water from entering inside the camera recorder when using it in the rain or snow or at the seashore or in other similar environments.**

- Failure to heed this caution may cause the camera recorder and/or cassette to malfunction (possibly leading to irreparable damage).

**Keep the camera recorder away from equipment (such as TV sets and TV game machines) that generate magnetic fields.**

- When the camera recorder is used on top of or in the vicinity of a TV set, the radiation of electromagnetic waves from the set may give rise to interference in the picture and/or sound.
- The strong magnetic fields generated by speakers or large motors may ruin the tape recordings or distort the images.
- The electromagnetic waves from microcomputers may have an adverse effect on the camera recorder or give rise to distortion in the images and sound.
- If the camera recorder is adversely affected by a component that generates magnetic fields to such an extent that it can no longer operate normally, turn off the power and remove the battery or disconnect the AC adapter from the power outlet, then re-install the battery or reconnect the AC adapter to the outlet. After this, switch the camera recorder's power back on.

**Do not use the camera recorder near radio transmitters or high-voltage equipment.**

- If the camera recorder is used near a radio transmitter or high-voltage equipment, the recorded pictures and/or sound may be adversely affected.

**When using the camera recorder on the seashore or other similar environment, take care to ensure that no sand or dust enter inside the camera recorder.**

- Sand and dust may damage the camera recorder and/or cassette. (Take particular care when inserting and ejecting the cassette.)

## AC adapter and battery

- When the temperature of the battery unit has risen to an extremely high level or dropped to an extremely low level or when the battery is not used for prolonged periods of time has become fully discharged, the "CHARGE" lamp flashes several times, and charging commences automatically.
- If the "CHARGE" lamp continues to flash even though the battery temperature is normal, consult your dealer as a problem may have developed within the battery or AC adapter.
- When the battery is warm, it takes longer than usual for the battery to be charged.
- When the AC adapter is used near a radio, the radio sound may be distorted. Use the adapter at a distance of at least one meter from the radio.
- Noise may be heard while the AC adapter is in use; however, this is normal and not indicative of any malfunctioning.

**When carrying the camera recorder, take care not to drop it.**

- A strong impact may damage the camera recorder body and render it incapable of proper operation.
- When carrying the camera recorder, always use the hand strap or shoulder strap and handle the camera carefully.

**Keep the camera recorder away from insecticide sprays and volatile liquids.**

- If the camera recorder comes into contact with insecticide sprays or volatile liquids, the camera body may become deformed or the surface coating may peel off.
- Ensure that the camera recorder does not remain in close contact with rubber or plastic products for prolonged periods of time.

**After use, be absolutely sure to remove the cassette and either remove the camera recorder's battery or disconnect its AC cable from the power outlet.**

- If a cassette is left inside the camera recorder, tape slack may develop and result in damage to the tape.
- If the battery is left inside the camera recorder for a prolonged period, its voltage may drop to such a low level that even after it has been recharged, it may not be possible to re-use it.

# Precautions for use

---

## Battery characteristics

This camera recorder uses a rechargeable lithium-ion battery which produces electrical energy by means of an internal chemical reaction. This reaction tends to be easily affected by the ambient temperature and humidity, and the period during which the battery can be effectively used decreases as the temperature becomes very high or low. The battery charge will last for only 5 minutes if the battery is used in an environment where the temperature is extremely low.

When the battery temperature rises to an abnormally high level, the protection function is activated, and it is not possible to use the battery for a while.

## Always remove the battery upon completion of operation.

Never fail to remove the battery from the camera recorder. (If it is left in the camera, a small amount of current will be consumed even when the camera recorder's power is off.) If the battery is left in the camera for a prolonged period, it will become excessively discharged to the extent that even after it has been recharged, it may not be possible to re-use it.

## Disposing of the battery

- Dispose of the battery when it has reached the end of its service life.
- Do not dispose of the battery in a fire as it may explode.

## Protect the battery terminals.

Ensure that the battery terminals are free from dust and foreign matter.

If the battery has been dropped, check that the battery body and terminals have not been bent out of shape.

Inserting a deformed battery into the camera recorder or mounting it in the AC adapter may result in damage to the camera recorder or AC adapter.

## LCD

- If the same image or characters are left displayed for a prolonged period on the LCD monitor or viewfinder, the image may be burned onto the screen. If this happens, keep the power off for several hours to restore the screen to its original condition.
- The liquid crystal parts are fabricated using high-precision technology. The screen has effective pixels that cover more than 99.99% of its area, but pixels may be missing or remain permanently lighted in less than 0.01% of the area. This is neither indicative of malfunctioning nor does it affect the images in any way.
- In locations where the temperature fluctuates considerably, condensation may form on the liquid crystal parts of LCD monitor. If this happens, wipe off the moisture using a soft, dry cloth.
- If the temperature of the camera recorder itself is very low, the LCD monitor may be slightly darker than usual immediately after the power has been turned on. Normal brightness is restored after the internal temperature has risen.

## Do not point the lens or viewfinder's eyepiece at the sun.

Doing so may damage the internal parts.

## Protective caps for the connectors

Keep the protective caps in place over any connectors which are not being used.



# Storage tips

---

When storing the camera recorder, eject the cassette from the camera recorder and remove the battery.

Store all components in a location where the humidity level is low and the temperature is relatively stable.

**Recommended temperature range:**

59°F to 77°F (15°C to 25°C)

**Recommended relative humidity:**

40% to 60%

**Camera recorder**

- Wrap the camera recorder in soft cloth to keep out dust.

**Battery**

- The battery's service life is reduced if the battery is stored in a location where the temperature is extremely high or extremely low.
- If the battery is stored in a location exposed to high concentrations of oily vapors and/or dust, the terminals may corrode or other problems may develop, possibly resulting in malfunctioning.
- **Do not bring metal objects (such as necklaces or hairpins) into contact with the battery terminals. The terminals may short circuit and generate heat, and touching them in this condition may cause severe burns.**
- Store the battery only when it is fully discharged. It is recommended that the battery be charged once a year when it is being stored long-term and that it be placed back in storage after it has been fully discharged using the camera recorder.

**Cassette tapes**

- Before storing a cassette tape, rewind the tape to its start. If a tape that has been stopped at some interim point along its length is stored for six months or more (this period of time differs depending on the storage conditions), tape slack will develop. Always rewind the tape to its start before storing it.
- Return cassette tapes to their original cases before storing them. Dust, direct sunlight (ultraviolet rays), humidity and other such conditions may damage the tapes. Dust contains particles of hard mineral substances, and if dust should enter inside a cassette, these particles may in turn be transferred to the heads and other parts, possibly resulting in their damage. Make a habit of always returning the cassettes to their original cases.
- Fast forward and rewind cassette tapes once every six months. If tapes are kept wound up for more than a year, they may become warped or distorted due to the expansion and contraction caused by changes in the temperature and humidity. In addition, layers of tape may stick together.
- Do not place cassette tapes near matter or equipment which emits strong magnetic fields.
- Extremely fine magnetic particles are contained in the coating of the tape surface, and it is here that the signals are recorded. Magnetic necklaces, toys and other such items may have stronger magnetic fields than suspected, which may erase recordings or give rise to noise in the pictures and sound.

# Parts and their functions

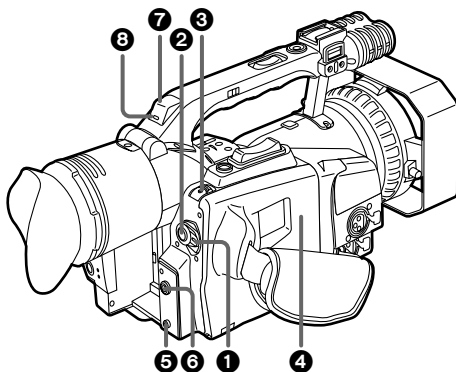

## 1 POWER switch

Move this switch while pressing the lock release button.

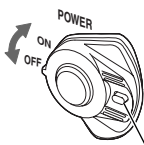

Lock release button

## 2 START/STOP button

When this button is pressed in the camera mode, shooting can be started or stopped. Operation is switched between the camera mode and VCR mode using the CAMERA/VCR button 14.

## 3 EJECT switch

To open the cassette holder, slide this switch in the direction of the arrow while pressing the lock release button. Do not operate the switch while recording is in progress. The cassette holder will open but recording will continue, so external light and/or dust will adversely affect the tape.

- **Do not insert or eject the cassette tape holding onto the cassette holder alone.** Insert or eject the tape with the camera recorder placed on a flat and stable surface or, alternatively, support the camera recorder with both hands so that it will be kept in a stable condition even if the cassette holder is opened.
- **Close the cassette holder after ensuring that the cassette mechanism has completed the eject operation.**



Lock release button

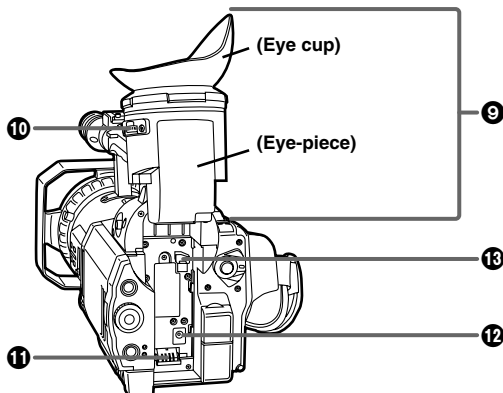

## 4 Cassette holder

## 5 CAM REMOTE jack (2.5 mm mini jack)

The remote control unit is connected to this jack to enable zooming and record start/stop to be initiated by remote control.

## 6 PHONES jack (3.5 mm stereo mini jack)

The headphones are connected to this jack to monitor the sound.

## 7 Remote control sensor (rear)

## 8 Tally lamp (rear)

This lights or blinks depending on the status of the camera recorder.

**Lights:** While shooting is in progress.

### Blinks:

- When a remote control operation has been received (about 8 blinks per second)
- When shooting is commenced (about 8 blinks per second)
- When the tape has come to the end (about 4 blinks per second)
- When a problem has arisen in the tape transport system (about 4 blinks per seconds)
- When there is little tape or battery charge remaining (once a second)

The settings for causing the tally lamp to flash are performed using the REC LAMP item on the setting menu OTHER FUNCTIONS screen. (See page 46)

## 9 Viewfinder

## 10 Diopter adjustment dial

This is adjusted in such a way that the viewfinder screen comes into sharp focus.

## 11 Power socket

## 12 DC INPUT connector (7.9V)

## 13 Battery eject button

# Parts and their functions

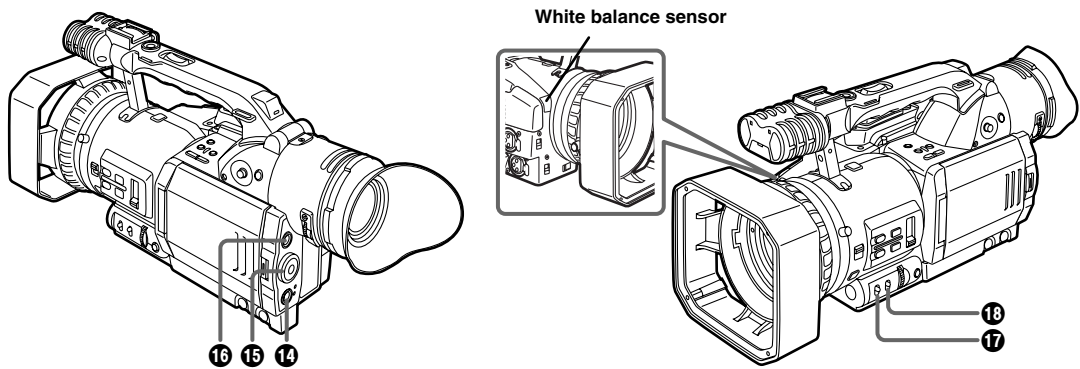

## 14 CAMERA/VCR button and lamp

Each time this button is pressed, the operation mode is switched between the camera mode and VCR mode, and the lamp of the selected mode lights.

Select the camera mode for shooting.

Select the VCR mode to check the tape contents or input and record video signals from an external source.

## 15 Scene file dial

This is used to select the scene files. (See page 34)

Settings tailored to various shooting conditions are stored in the positions of this dial.

During shooting, the necessary file can be instantly loaded using the dial.

## 16 END SEARCH button

When this button is pressed in the VCR mode, the unrecorded blanks on the video tape are searched, and the still picture mode is established about one second before an unrecorded blank.

The part which was shot last can also be searched using the END SEARCH item setting on the setting menu PLAYBACK FUNCTIONS screen. (See page 42)

- When one tape is replaced with another, the part which was shot last can be searched using this button.
- If no signals have been recorded on the tape, the tape stops at the tape end.
- This function may not operate properly if there is an unrecorded blank near the tape start or at a point along the tape.
- Before proceeding with recording, check the picture which has been searched.

## 17 GAIN switch

When the camera screen is too dark, change the setting of this switch to boost the gain and make the screen brighter. The M and H gain values are set using the MID GAIN item and HIGH GAIN item on the setting menu SW MODE screen. (See page 40)

**L** : The switch is normally kept at this position. (0 dB)

**M** : The gain of the camera video amplifier is boosted. (Factory setting: 6 dB)

**H** : The gain of the camera video amplifier is further boosted. (Factory setting: 12 dB)

- In the progressive mode, the screen is controlled by a fixed gain value regardless of the position of the GAIN switch.

## 18 WHITE BAL switch

This is used to set the white balance.

**A or B** :

The white balance value adjusted by the AWB button 19 is stored in the memory.

**PRST (preset)** :

Set the switch to this position in cases where, for instance, there is no time to adjust the white balance.

The 3200K and 5600K white balance values are stored in the memory.

Press the AWB button to switch between the two values.

- The ATW (Auto Tracking White) function can be allocated to the A, B or PRST position using the ATW item on the setting menu SW MODE screen. (See page 40)

- What kind of light source is being used during shooting is determined by the white balance sensor.

Do not block the front of the white balance sensor with your hand or any other object during shooting or the ATW function will not operate properly.

# Parts and their functions

Zoom ring pin

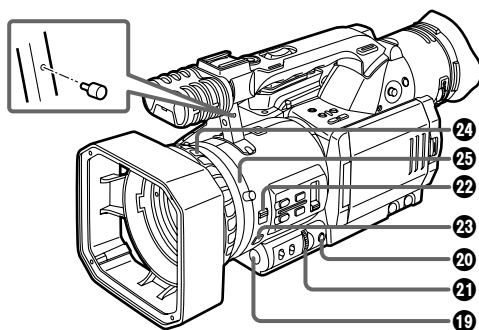

## 19 AWB button

When this button is pressed while the WHITE BAL switch 18 is set to the A or B position, the white balance is automatically adjusted, and the white balance value is stored in the memory.

If this button is then held down, the black balance is adjusted.

In the progressive mode, the black balance is adjusted following the automatic adjustment of the white balance simply by pressing this button.

When this button is pressed while the WHITE BAL switch 18 is set to the PRST position, the current white balance value is displayed.

When the AWB button is pressed again, the 3200K and 5600K white balance values are selected alternately.

- While recording is in progress, the black balance cannot be adjusted.

## 20 IRIS button

Each time this button is pressed, the method of adjusting the lens iris is switched between the auto mode and manual mode.

## 21 IRIS dial

This is used to adjust the lens iris.

When the IRIS button 20 is set to the manual mode, this dial is used to adjust the lens iris.

Even in the auto mode, the lens iris can be adjusted using this dial.

- The direction in which the IRIS dial is turned and iris control can be set using the IRIS DIAL item on the setting menu SW MODE screen. (See page 40)

## 22 FOCUS switch

This is used to select the method of controlling the focus.

### A (AUTO):

Auto focus mode

### M (MANUAL):

Manual focus mode

The focus ring 24 is controlled manually to adjust the focus.

∞:

After the focal length has been set to infinity, the manual focus mode is established. Even if the FOCUS switch is set to the ∞ position, it will return to the M (MANUAL) position.

- Even when the manual focus mode is established, the AUTO button 27 setting takes priority if it is pressed.
- If flicker occurs, the auto focus control may not be exercised properly, so select a shutter speed suited to the lighting. (See page 29)
- In the progressive mode, the manual focus mode is established.

## 23 PUSH AUTO button

While this button is pressed with the FOCUS switch set to the M (MANUAL) position, the auto focus mode is established, and the focus is adjusted.

## 24 Focus ring

## 25 Zoom ring

If the zoom ring pin is not required, fit it into the threaded hole under the handle so that it will not be lost.

# Parts and their functions

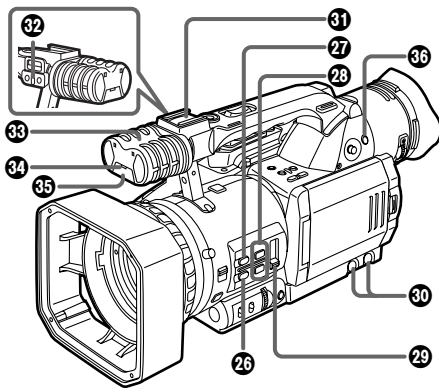

## 26 INDEX button

When the INDEX button is pressed while shooting or recording is in progress, the index signal is recorded on the tape.

When it is pressed while shooting or recording has been temporarily stopped, the recording of the index signal is set to standby. If shooting or recording is commenced in this status, the index signal will then be recorded on the tape.

By recording the index signal, searches (index searches) can be conducted during playback. (See page 59)

## 27 AUTO button

When the AUTO button is pressed, the operation mode which was set on the setting menu AUTO SW screen is established, and “[A]” appears in the upper part of the viewfinder and LCD monitor.

On the setting menu AUTO SW screen, the mode of the operation to be performed automatically (auto iris, auto gain control, auto tracking white or auto focus) when the AUTO button is pressed is set. (See page 41)

The setting is released when the button is pressed again.

## 28 USER1 and USER2 buttons

One of nine functions can be allocated to the USER1 button and one can be allocated to the USER2 button.

In accordance with the subject concerned, the shooting conditions can be instantly selected or fade effects can be added to the images.

For details, refer to the USER1 item and USER2 item (page 41) on the setting menu SW MODE screen.

## 29 ND FILTER switch

This is used to select the ND filter (for adjusting the light quantity) to be used.

**OFF:** The ND filter is not used.

**1/8 :** The light quantity is reduced to about one eighth.

**1/64:** The light quantity is reduced to about one sixty-fourth.

## 30 AUDIO controls

These are used to adjust the recording level of the audio signals which have been input to the built-in microphone 33 and INPUT 1 and 2 connectors 42.

Adjust the recording level of the audio signals using these controls, irrespective of the setting selected for the MIC ALC item on the RECORDING SETUP screen of the setting menu (page 43).

It is recommended that the center position normally be selected for use.

- They cannot be used to adjust the audio signals which have been input to the AUDIO IN/OUT CH1 and CH2 connectors 39.

## 31 Light shoe

A video light, for instance, is attached to this shoe.

## 32 Microphone shoe

The accessory microphone holder is attached to this shoe so that a microphone (optional accessory), etc. can be mounted. (See page 54)

## 33 Microphone (built-in, stereo)

Do not apply a strong load from an external source to this microphone as it may damage the microphone.

## 34 Tally lamp (front)

Refer to the details on the tally lamp (rear) 8.

## 35 Remote control sensor (front)

## 36 MENU button

When this button is pressed, the menu mode is established, and the setting menu screen is displayed in the viewfinder and on the LCD monitor.

When it is pressed again, the menu mode is released.

# Parts and their functions

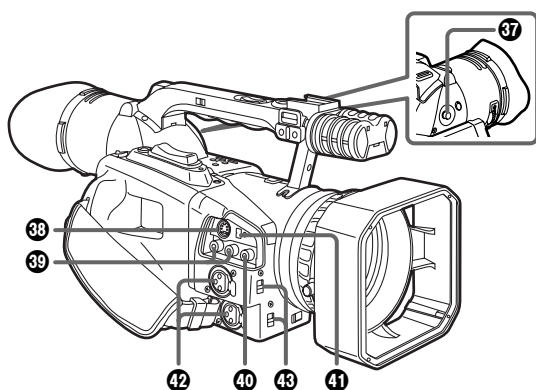

## 37 OPERATION lever

This lever is used to operate the VCR and conduct the menu operations.

### [In the VCR mode]

“▶” :

When the lever is tilted in the “▶” direction in the stop mode, the tape is played back.

When it is tilted in the same direction during playback, the variable speed search mode (see page 59) is established, and the tape is played back at the 1× speed. (Sound is not played back.)

“▶▶” :

When the lever is tilted in the “▶▶” direction in the stop mode, the tape is fast forwarded.

When it is tilted in the same direction during playback, the tape is cued at 10× speed.

“◀◀” :

When the lever is tilted in the “◀◀” direction in the stop mode, the tape is rewound.

When it is tilted in the same direction during playback, the tape is reviewed at 10× speed.

“■” :

When the lever is tilted in the “■” direction, the tape is stopped.

“|||” :

When the lever is pressed during playback, the tape is set to the pause (temporary stop) mode.

### [In the menu mode]

“▲” :

When the lever is tilted in the “▲” direction, the items displayed on the menu screen are moved upward.

“▼” :

When the lever is tilted in the “▼” direction, the items displayed on the menu screen are moved downward.

“|||” :

Press the lever to change a setting.

### [In the camera mode]

“▶▶”

When the lever is tilted in the “▶▶” direction in the shooting pause mode, the tape is played back in the “▶▶” direction at 1× speed while the lever is tilted.

“◀◀”

When the lever is tilted in the “◀◀” direction in the shooting pause mode, the tape is played back in the “◀◀” direction at 1× speed while the lever is tilted.

- The scenes shot up until now can be checked in the shooting pause mode.

## 38 S-VIDEO IN/OUT connector

This is the S-video input/output connector.

## 39 AUDIO IN/OUT CH1 and CH2 connectors (pin jacks)

These are the input/output connectors for the audio signals.

## 40 VIDEO IN/OUT connector (pin jack)

This is the input/output connector for the video signals.

## 41 DV connector

An IEEE1394 (4-pin) cable (optional accessory) is connected here.

Video signals, audio signals or time codes, for instance, can be transmitted digitally.

## 42 INPUT 1, 2 connectors (XLR, 3-pin)

External microphones or audio components are connected here.

## 43 INPUT 1/2 switch

This is used to switch the audio input signals which are connected to the INPUT 1 and 2 connectors.

### LINE:

The audio input signals from the audio component serving as the line input are selected; their input level is 0 dBu.

### MIC:

The audio input signals from the external microphone(s) are selected; their input level is -50 dBu.

The input level can be changed to -60 dBu using the MIC GAIN 1 and MIC GAIN 2 items on the setting menu RECORDING SETUP screen. (See page 43)

# Parts and their functions

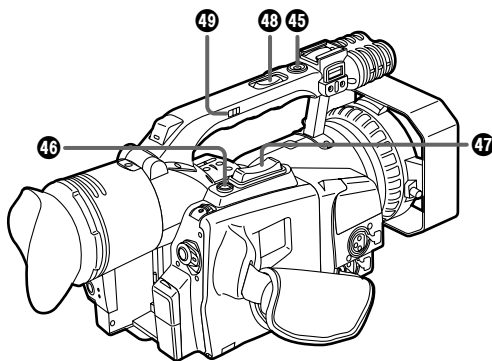

## 44 ZOOM switch

This is used to select motor-driven zoom operations or manual zoom operations.

### SERVO:

For motor-driven zoom operations  
(At this position, do not attempt to perform manual zoom operations or malfunctioning may result.)

### MANU:

For manual zoom operations

## 45 START/STOP button (on the handle)

When this button is pressed in the camera mode, shooting start or stop is selected.

The camera mode and VCR mode are switched using the CAMERA/VCR button 14.

## 46 REC CHECK button

When this button is pressed in the shooting pause mode, the picture and sound immediately before shooting was stopped are played back for several seconds, and the shooting pause mode is established at the original position on the tape.

## 47 Zoom button

When the ZOOM switch is at the SERVO position, motor-driven zoom operations are performed.

When this button is pressed lightly, zoom operations are performed at a low speed; when it is pressed with force, they are performed at a high speed.

## 48 Zoom button (on the handle)

## 49 HANDLE ZOOM switch

This switch is used to select one of the three speeds for the zoom operations conducted using the zoom button 48 on the handle.

The speed is set using the HANDLE ZOOM item on the setting menu SW MODE screen. (See page 40)

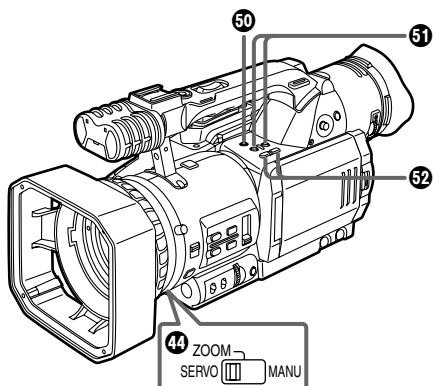

## 50 AUDIO DUB button

When the pause status is established in the VCR mode and this button is pressed, the mode in which audio dubbing can be started is established.

Press "II" of the OPERATION lever 37 to record the sound. To stop the recording, tilt the OPERATION lever in the "■" direction.

The audio input used for audio dubbing is set using the A DUB INPUT item on the setting menu AV IN/OUT SETUP screen. (See page 44)

- Before proceeding with the audio dubbing, select "12 bit" as the AUDIO REC item setting on the setting menu RECORDING SETUP screen and then start shooting. (See page 43)

## 51 VCR REC buttons

When these two buttons are pressed at the same time in the stop status of the VCR mode, the video signals from the connected component are recorded.

When they are pressed at the same time in the playback pause status of the VCR mode, the recording standby status is established.

Each time "II" of the OPERATION lever 37 is pressed, the status alternates between recording and recording standby.

To stop recording, tilt the OPERATION lever in the "■" direction.

- Before proceeding to record, check that the video signals have been input.

## 52 AUDIO MON/VAR buttons

These buttons are used to adjust the volume at which the sound is to be output from the internal speaker 55 or PHONES jack 6.

They cannot be adjusted in the camera mode.

The playback direction and playback speed are changed in the variable speed search mode. (See page 59)

When these buttons are pressed in the pause status, the tape is played back frame by frame.

# Parts and their functions

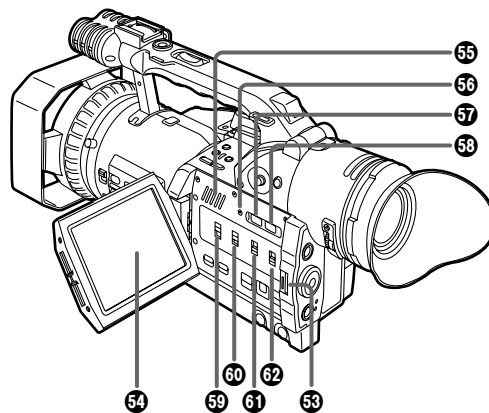

## 53 OPEN button

Press the OPEN button in the direction of the arrow to open the LCD monitor 54.

When the LCD monitor is opened, the image on the viewfinder switches to the LCD monitor.

The image can be switched using the EVF MODE item on the setting menu DISPLAY SETUP screen. (See page 45)

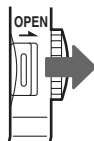

## 54 LCD monitor

## 55 Internal speaker

## 56 RESET button

If the camera recorder cannot be operated even though its power is on or some other form of trouble has occurred, use a pointed object to press the RESET button. This will reset the system microcomputer.

Even after resetting has been initiated, the entered setting menu values and memory contents will not be erased.

Refrain from pressing the RESET button when the camera recorder is operating properly.

## 57 SHUTTER button

Press this button to change the shutter speed.

After pressing this button, press the SPEED SEL button 58 to select the shutter speed. (See page 29)

## 58 SPEED SEL button

After having pressed the SHUTTER button 57, press this button to select the shutter speed. (See page 29)

## 59 CH1 SELECT switch

This switch is used to select the input signals which are to be recorded on the audio channel 1 track.

### INT (L):

Audio signals of the left (L) channel of the internal microphone

### INPUT1:

Audio signals which are input to the INPUT 1 connector

### INPUT2:

Audio signals which are input to the INPUT 2 connector

## 60 CH2 SELECT switch

This switch is used to select the input signals which are to be recorded on the audio channel 2 track.

### INT (R):

Audio signals of the right (R) channel of the internal microphone

### INPUT2:

Audio signals which are input to the INPUT 2 connector

## 61 INPUT 1 switch (MIC POWER +48 V)

When this switch is set to ON, +48 V power (power supply for the phantom mic) is supplied to the INPUT 1 connector.

## 62 INPUT 2 switch (MIC POWER +48 V)

When this switch is set to ON, +48 V power (power supply for the phantom mic) is supplied to the INPUT 2 connector.



# Parts and their functions

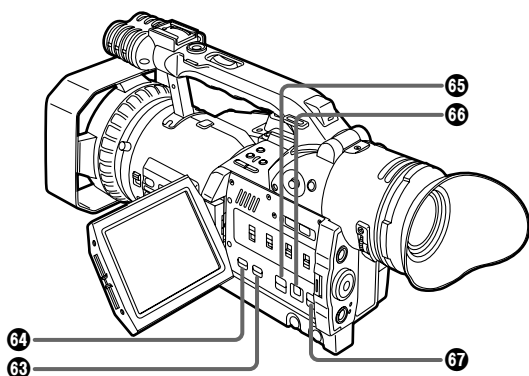

## 63 COUNTER RESET button

This button is used to reset the counter value on the counter display and the memory counter value to zero. It cannot reset the time code or user's bit.

## 64 COUNTER button

This button is used to select what data is to be displayed on the counter display which is in the viewfinder and on the LCD monitor. Each time it is pressed, the data to be displayed changes.

### COUNTER:

The counter value is displayed.

### M COUNTER:

The counter value in the memory stop mode is displayed.

**TC** : The time code is displayed.

**UB** : The user's bit is displayed.

**FR** : The frame rate information (30P, 24P or 24PA) when shooting is to be performed in the progressive mode, and the sequence information used for frame conversion are displayed.

### Blank display :

No data is displayed.

### Memory stop mode

The memory stop mode is established when the display is switched to M COUNTER using the COUNTER button.

- ① Switch the display to M COUNTER, and press the COUNTER RESET button 63 at any tape position to reset the counter value.
  - ② Proceed with playback or shooting.
  - ③ Establish the VCR mode using the CAMERA/VCR button.
  - ④ When the tape is now rewound or fast forwarded, it stops traveling automatically near where the counter value was reset.
- If the counter value is reset at the OUT point during audio dubbing, audio dubbing can be stopped in the memory stop mode.

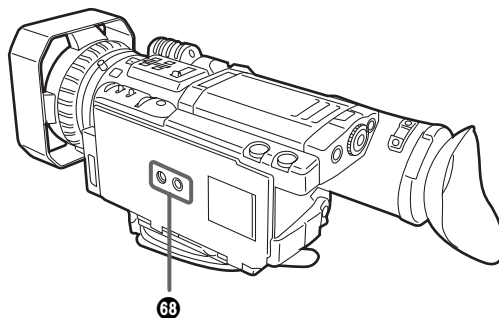

## 65 MODE CHK button

When this button is pressed, the current camera status setting can be checked in the viewfinder and on the LCD monitor.

## 66 ZEBRA button

When this button is pressed in camera mode, a zebra pattern or marker appears in the viewfinder and on the LCD monitor, enabling the brightness of the subject to be checked. Each time it is pressed, the display changes as shown below.

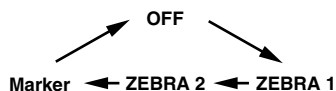

The level of each zebra pattern can be set using the ZEBRA DETECT 1 item and ZEBRA DETECT 2 item on the setting menu DISPLAY SETUP screen.

Display of the marker can also be switched ON/OFF with the MARKER item on this screen. (See page 45)

### Zebra pattern

Parts that may be whitened out due to overexposure are displayed using a striped pattern.

## 67 OIS button

This button is used to set camera shake compensation to ON or OFF. When the compensation is ON,  appears in the viewfinder and on the LCD monitor.

Select ON or OFF to suit the shooting conditions.

When shooting using a tripod, the OFF setting is recommended.

## 68 Tripod mounting hole

# Parts and their functions

## Remote control unit

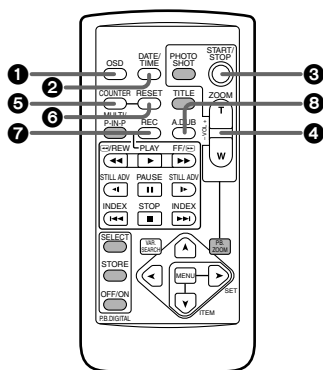

The buttons listed below are for functions which are not featured on the camera recorder.

- PHOTO SHOT
- MULTI/P-IN-P
- STORE
- PB. ZOOM
- TITLE
- SELECT
- OFF/ON
- ◀

### 1 OSD button

When this button is pressed, the information displayed in the viewfinder and on the LCD monitor is added to the video signals, and it can be displayed on a TV monitor as well. When it is pressed again, the display on the TV monitor is cleared.

### 2 DATE/TIME button

When this button is pressed, the shooting date (year/month/day) and/or time are displayed in the viewfinder and on the LCD monitor. Each time it is pressed, the display is switched in the sequence shown below.

	No display
	Time display
	Date display
	Time and date display

### 3 START/STOP button

This button has the same function as the START/STOP button on the camera recorder body.

### 4 ZOOM/VOL buttons

During shooting, these buttons are used to conduct motor-driven zoom operations. The zoom speed is fixed at the medium speed. During tape playback, they are used to adjust the volume at which the sound is to be output from the internal speaker and PHONES jack.

### 5 COUNTER button

This button has the same function as the COUNTER button on the camera recorder body.

### 6 COUNTER RESET button

This button has the same function as the COUNTER RESET button on the camera recorder body.

### 7 REC button

When this button is pressed together with the PLAY button while operation is stopped in the VCR mode, the video signals from the connected component are recorded. When it is pressed together with the PLAY button during playback pause in the VCR mode, the recording standby status is established. Each time the PAUSE (||) button is pressed, the status is switched between recording and recording standby. To stop recording, press the STOP (■) button.

### 8 A. DUB button

This button has the same function as the AUDIO DUB button on the camera recorder body.

# Parts and their functions

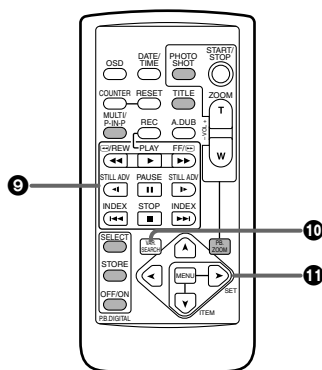

## 9 VCR operation buttons

### REW button (◀◀)

This button has the same function as the OPERATION lever on the camera recorder body.

### FF button (▶▶)

This button has the same function as the OPERATION lever on the camera recorder body.

### PLAY button (▶)

When this button is pressed in the VCR mode, the tape is played back.

When it pressed together with the REC button, the video signals from the connected component are recorded.

### STILL ADV buttons (◀, ▶)

When either button is pressed during tape playback, slow-motion playback results.

When it is pressed in the pause status, frame advance playback results.

(◀ in the reverse direction, ▶ in the forward direction)

### INDEX buttons (◀◀, ▶▶)

When either button is pressed during tape playback, the start of a recorded section is searched.

(◀◀ in the reverse direction, ▶▶ in the forward direction)

### PAUSE button (⏸)

This button has the same function as the OPERATION lever on the camera recorder body.

### STOP button (■)

This button has the same function as the OPERATION lever on the camera recorder body.

## 10 VAR. SEARCH button

When this button is pressed during playback, the variable search mode is established, and "1×" is displayed in the viewfinder and on the LCD monitor. When the "▲" or "▼" button among the SET buttons 11 is pressed, the playback speed is changed.

Each time the "▲" or "▼" button is pressed, the playback speed is changed by one setting in the following sequence: 1/5× (or 1/3× in the LP mode), 1×, 2×, 5×, 10× and 20×.

Use the "▲" button to change the speed in the forward direction and the "▼" button to change it in the reverse direction.

## 11 SET buttons

### MENU button:

This button has the same function as the MENU button on the camera recorder body.

### "▲" button:

When this is pressed in the menu mode, the items displayed on the menu screen are moved upward.

When it is pressed in the search mode, the speed is changed in the forward direction.

### "▼" button:

When this is pressed in the menu mode, the items displayed on the menu screen are moved downward.

When it is pressed in the search mode, the speed is changed in the reverse direction.

### "▶" button:

Press this in the menu mode to change settings.

# Remote control unit

## Installing the battery

- 1** While pushing the knob in the direction of the arrow, pull out the holder.

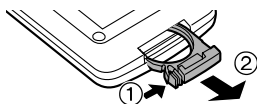

- 2** Insert the battery with the “+” marking face up.

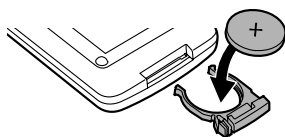

- 3** Return the holder to its original position.

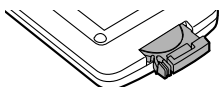

- When the battery (CR2025) has completely run down, replace it with a new one. (The battery life is about one year although it depends on how often the remote control unit is used.) If the remote control unit is operated near the camera recorder’s remote control sensor and the camera recorder fails to operate, it means that the battery has run down.
- **Keep batteries out of the reach of small children.**

## Remote control unit settings

In order to prevent mistakes made in operations performed using remote control when two camera recorders are operated at the same time, the operation buttons on the camera recorder and accessory wireless remote control unit can be set to work for “VCR1” applications and for “VCR2” applications.

### Setting method

- **Wireless remote control unit**  
When the STOP (■) and STILL ADV (▶) buttons among the VCR operation buttons are pressed at the same time, the operation buttons on the remote control unit are set to be used for VCR1.  
Similarly, when the STOP (■) and STILL ADV (◀) buttons among the VCR operation buttons are pressed at the same time, the operation buttons on the remote control unit are set to be used for VCR2.  
When the battery in the remote control unit has been replaced, the operation buttons are set to be used for VCR1.
- **Camera recorder body**  
Set VCR1 and VCR2 using the REMOTE item on the setting menu OTHER FUNCTIONS screen. (See page 46)

If the camera recorder body and remote control unit settings are at variance, “REMOTE” in red letters lights up and is displayed in the viewfinder and on the LCD monitor.

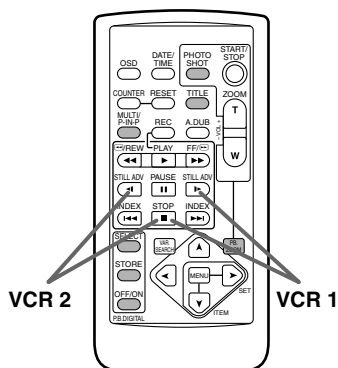

# Charging the battery

Fully charge the battery using the AC adapter before use.

It is recommended that a spare battery be kept on hand just in case it is needed.

**1 Place the battery flat along the  mark on the AC adapter, and slide it into position.**

- If the DC cable is connected to the AC adapter, disconnect it before proceeding. The battery cannot be charged if this cable is connected.

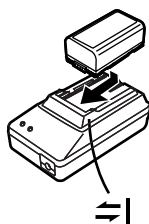

**2 Connect the AC cable to the power outlet.**

- The “POWER” lamp and “CHARGE” lamp on the AC adapter light up, and charging commences.
- If the “CHARGE” lamp fails to light when the battery has been mounted, re-mount the battery.

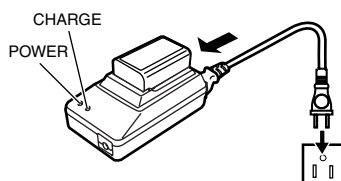

**3 Upon completion of the charging, the “CHARGE” lamp on the AC adapter goes off.**

**4 Slide the battery out of position and remove it.**

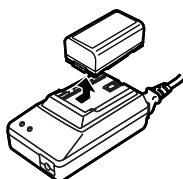

## Charging and recording times of accessory battery

Charging time	Continuous recording time
Approx. 120 minutes	Approx. 90 (80) minutes

- The table above gives the approximate durations. The figure in parentheses is the duration when the LCD monitor is used.
- The durations in the above table apply when the ambient temperature is 68°F (20°C) and the relative humidity is 60%. Charging may take longer at other temperature and humidity levels.

- **Do not bring metal objects (such as necklaces or hairpins) into contact with the battery terminals. The terminals may short circuit and generate heat, and touching them in this condition may cause severe burns.**
- The battery heats up during operation and during charging, as does the camera recorder body.
- If recording and stop operations are repeated more than is necessary, the recording time will be less than the values given in the above table.
- Store the battery only when it is fully discharged. It is recommended that the battery be charged once a year when it is being stored long-term and that it be placed back in storage after it has been fully discharged using the camera recorder.
- When the temperature of the battery unit has risen to an extremely high level or dropped to an extremely low level or when the battery is not used for prolonged periods of time has become fully discharged, the “CHARGE” lamp flashes several times, and charging commences automatically.
- If the “CHARGE” lamp continues to flash even though the battery temperature is normal, consult your dealer as a problem may have developed within the battery or AC adapter.
- When the battery is warm, it takes longer than usual for the battery to be charged.
- When the AC adapter is used near a radio, the radio sound may be distorted. Use the adapter at a distance of at least one meter from the radio.
- Noise may be heard while the AC adapter is in use; however, this is normal and not indicative of any malfunctioning.
- The battery cannot be charged while supplying power from the AC adapter to the camera recorder.

## Mounting the battery

- 1 Raise the viewfinder.

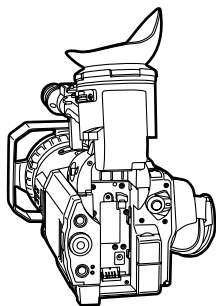

- 2 Push the battery straight in, and slide it downward until it clicks into position.

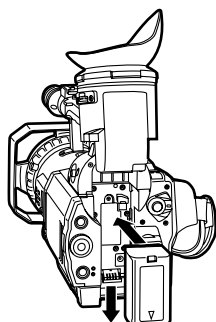

- 3 Return the viewfinder to its original position.

## Supplying power from the AC adapter

- 1 Raise the viewfinder.

- 2 Push the battery-type connector on the DC cable straight in, and slide it downward until it clicks into position.

- 3 Connect the DC cable to the AC adapter.

- 4 Connect the AC cable to the power outlet.

- 5 Return the viewfinder to its original position.

### CAUTION:

This unit will operate on 110/120/220/240V AC. An AC plug adapter may be required for voltages other than 120V AC.

If a conversion plug is required, consult with your dealer as to which one is to be purchased.

### Removing the battery

While pressing the battery eject button, slide the battery upward to remove.

- Set the POWER switch to OFF, and check that the CAMERA/VCR lamp has gone off before removing the battery.
- Support the battery with your hand to ensure that it will not drop.

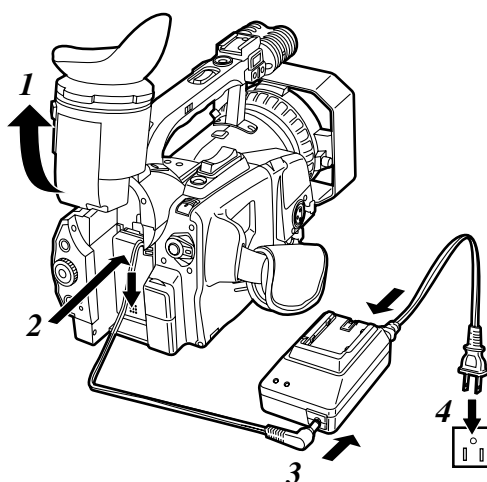
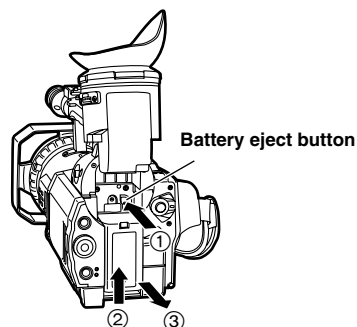

**Connect the AC adapter correctly as shown in the figure.**

- The battery cannot be charged while supplying power from the AC adapter to the camera recorder.

# Cassette tapes

## Inserting a cassette tape

**Do not insert or eject a cassette tape by taking hold of the cassette holder alone.**

Insert or eject the tape with the camera recorder placed on a flat and stable surface or, alternatively, support the camera recorder with both hands so that it will be kept in a stable condition even if the cassette holder is opened.

- 1 Check that the power supply (battery or AC adapter) is connected to the camera recorder.
- 2 While pressing the lock release button, slide the EJECT switch in the direction of the arrow to open the cassette holder.



Lock release button

- 3 Insert the cassette tape as shown in the figure below.

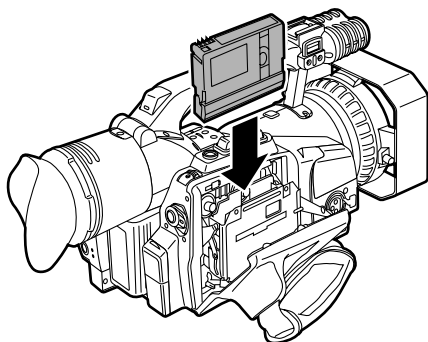

- 4 Push the part marked "PUSH CLOSE" to close the cassette holder securely.
  - Operations cannot be performed while the cassette holder is open.

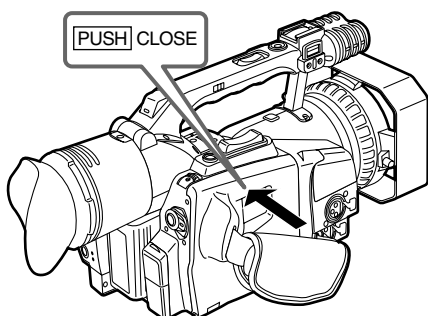

- Also, before removing the cassette tape, check that the power supply is connected to the camera recorder, then slide the EJECT switch.
- If the a cassette is not going to be inserted immediately after one has been removed, keep the cassette holder closed.
- Do not attempt this operation while recording is in progress. The cassette holder will open but recording will continue, so external light and/or dust will adversely affect the tape.

### To prevent accidental erasure of recordings

Set the cassette tab to "SAVE" in order to prevent what has been recorded on the tape from being erased by mistake.

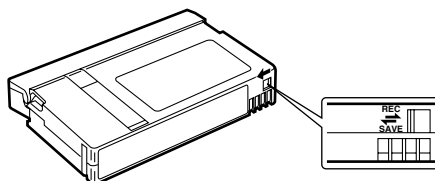

■ Use of the following mini DV cassette tapes is recommended for this camera recorder:

- AY-DVM30 (30 minutes in the SP mode)
- AY-DVM60 (60 minutes in the SP mode)

- Do not use 80-minute mini DV cassette tapes.

■ Even when material is shot in the LP mode, the picture quality will not deteriorate but mosaic-type noise may occur or certain restrictions may apply to some of the functions.

In the following cases, mosaic-type noise may occur and/or proper operation may not be possible.

- When a tape which was shot by this camera recorder in the LP mode is played back in another digital video component
- When a tape which was shot by another digital video component in the LP mode is played back in this camera recorder
- When a tape which was shot by this camera recorder in the LP mode is played back in a digital video component which is not equipped with the LP mode
- When slow or frame advance playback is performed
- When the camera search function is used

■ Audio dubbing is not possible in the LP mode as the track width on the tape is narrower than the head width.

## Adjusting the hand strap

---

Adjust the hand strap to match the size of your hand.

- 1 Open the cover, and adjust the strap length.
- 2 Return the cover to its original position.
  - Ensure that the cover is closed securely and tightly.

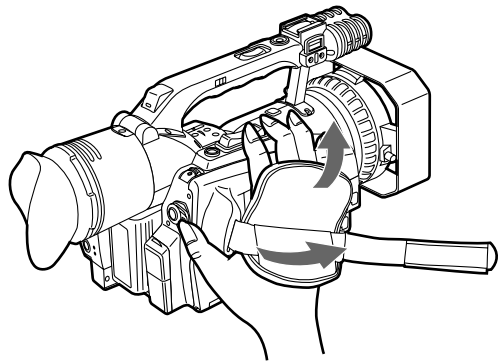

## Attaching the shoulder strap

---

It is recommended that the shoulder strap be attached to ensure that you do not drop the camera recorder.

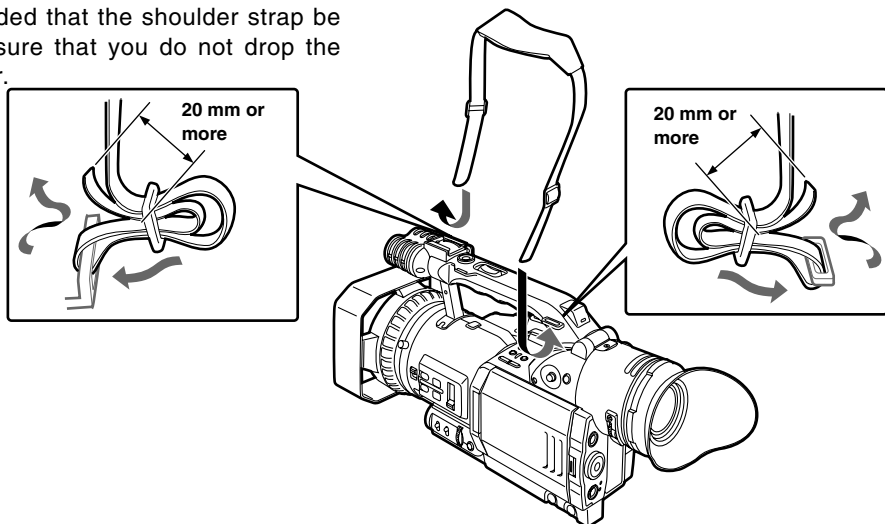

## Mounting the lens hood

---

### Removing the lens hood

- Loosen the fixing screw, and turn the lens hood counterclockwise to remove.

### Mounting the lens hood

- Position the lens hood so that its mark is facing upward, and fit the hood onto the lens.
- Turn the lens hood clockwise, and secure it using the fixing screw.

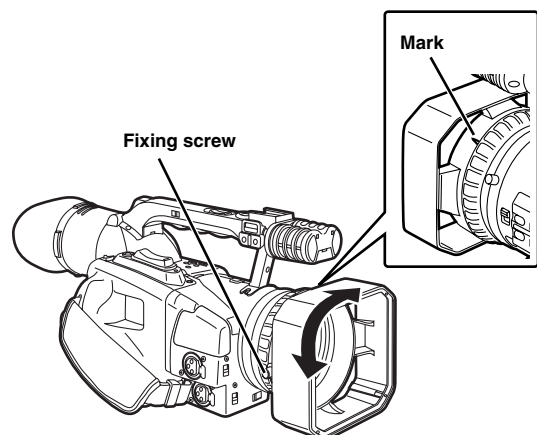



# Viewfinders

This camera recorder has two viewfinders: a viewfinder that uses a small LCD, and a 3.5-inch LCD monitor.

Use the one that better suits the application and the shooting conditions concerned.

- The brightness and color tones may differ between the images in the viewfinder and on the LCD monitor and the images on a TV monitor.

Use the TV monitor when performing the final check of the images.

## Using the viewfinder

- 1 Set the POWER switch on the camera recorder to ON, and check that an image appears in the viewfinder.

- Keep the LCD monitor closed.

- 2 Position the viewfinder where its screen images can be seen most comfortably.

- The viewfinder can be raised perpendicularly up to angle of about 90 degrees.

- 3 Adjust the diopter adjustment dial in such a way that the characters on the viewfinder screen come into sharp focus.

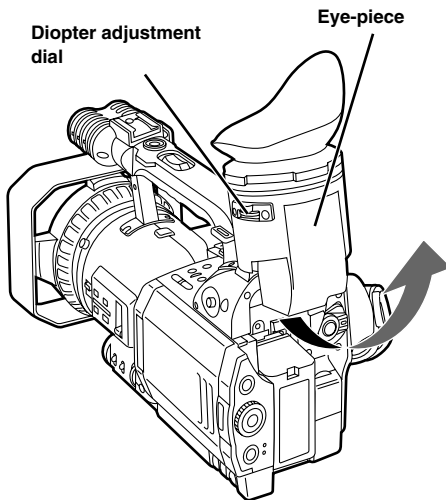

**Do not point the viewfinder's eye-piece at the sun.**

This may damage the internal parts.

- 4 Select YES as the setting for the LCD/EVF SET item on the setting menu DISPLAY SETUP screen.

- For details on the menu operations, refer to page 37.

- 5 Select the EVF BRIGHTNESS item, and tilt the OPERATION lever in the ▲ or ▼ direction to adjust the screen's brightness. (If the remote control unit is used, press the "▶" button among the SET buttons.)

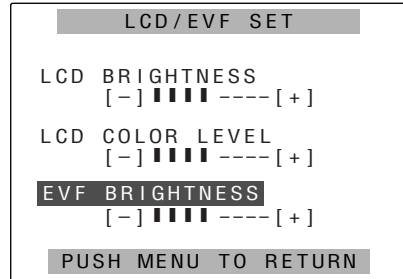

- 6 Press the MENU button three times to release the menu mode.

When ON is selected as the setting for the EVF MODE item on the setting menu DISPLAY SETUP screen, images will always appear in the viewfinder even when the LCD monitor is opened.

### Attaching the eye cup

To attach the eye cup, align the projections on the eye cup holder and eye cup, and fit the holder and eye cup together.

- Turning the eye cup after attaching it to its holder may cause the holder to become disengaged.

If the eye cup holder becomes disengaged, refer to the procedure described in "Viewfinder maintenance" (page 64) to reattach it.

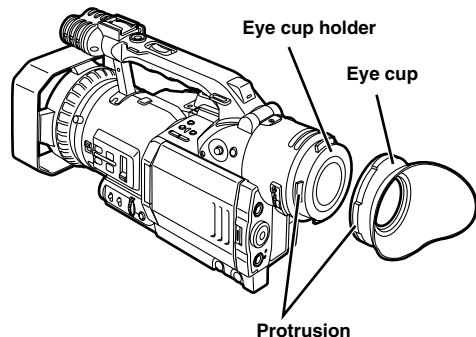

# Viewfinders

## Using the LCD monitor

1 Set the camera recorder's POWER switch to ON.

2 Press the OPEN button in the direction of the arrow ① to open the LCD monitor.

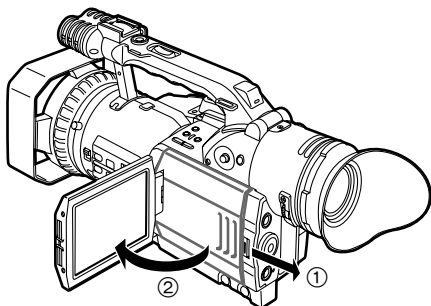

3 Position the LCD monitor where its screen images can be seen most comfortably.

- The LCD monitor can be rotated up to 180 degrees toward the lens and up to 90 degrees toward you.

**Forcing it beyond these angles or closing it while it is still in the rotated position may cause the camera recorder to malfunction.**

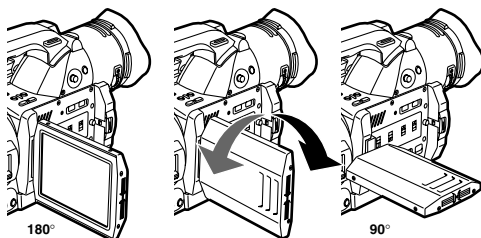

4 Select YES as the setting for the LCD/EVF SET item on the setting menu DISPLAY SETUP screen.

- For details on the menu operations, refer to page 37.

5 Select the LCD BRIGHTNESS item, and tilt the OPERATION lever in the ▲ or ▼ direction to adjust the screen's brightness. (If the remote control unit is used, press the "▶" button among the SET buttons.)

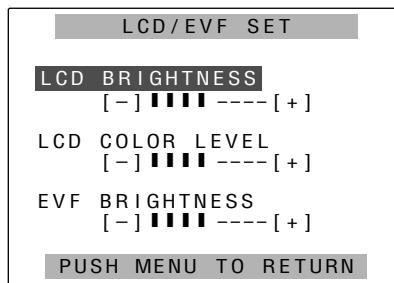

6 Select the LCD COLOR LEVEL item, and tilt the OPERATION lever in the ▲ or ▼ direction to adjust the screen's color level. (If the remote control unit is used, press the "▶" button among the SET buttons.)

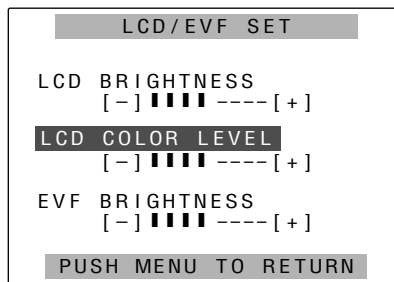

7 Press the MENU button three times to release the menu mode.

- When closing the LCD monitor, ensure that it is closed properly.
- When the LCD monitor has been turned toward the lens (for face-to-face shooting), both the viewfinder and LCD monitor light up at the same time.

# Setting the calendar

Presented below is a sample setting where the calendar is set to **December 25, 2002** and the time is set to **5:20 PM**.

**1** Set the camera recorder's POWER switch to ON.

**2** Select YES as the setting for the CLOCK SET item on the setting menu OTHER FUNCTIONS screen.

- For details on the menu operations, refer to page 37.

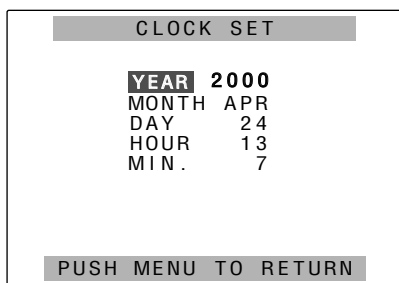

**3** Tilt the OPERATION lever in the ▲ or ▼ direction and set YEAR to **2002**. (If the remote control unit is used, press the “▶” button among the SET buttons.)

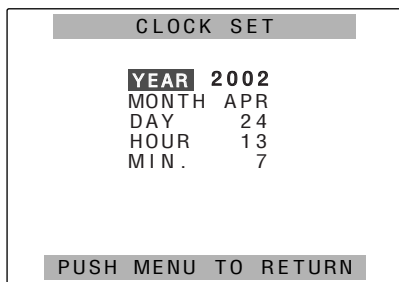

The year can be set from 2000 to 2089.

**4** Press “■” of the OPERATION lever, and move the setting item to **MONTH**. (If the remote control unit is used, press the “▼” button among the SET buttons.)

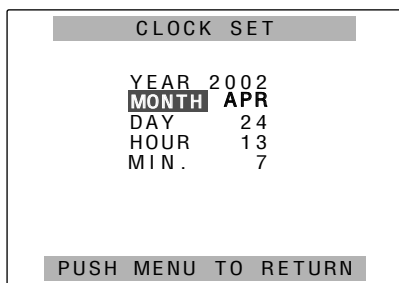

**5** Tilt the OPERATION lever in the ▲ or ▼ direction and set MONTH to **DEC**. (If the remote control unit is used, press the “▶” button among the SET buttons.)

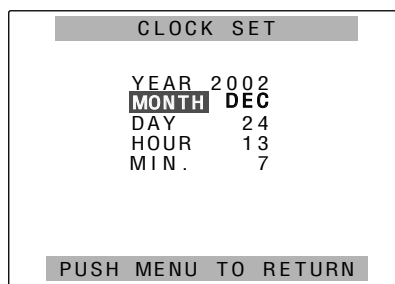

**6** In the same way, press “■” of the OPERATION lever, and move the setting item to **DAY, HOUR** and **MIN**. (If the remote control unit is used, press the “▼” button among the SET buttons.)

**7** Similarly, tilt the OPERATION lever in the ▲ or ▼ direction and set **25** for DAY, **17** for HOUR and **20** for MIN. (If the remote control unit is used, press the “▶” button among the SET buttons.)

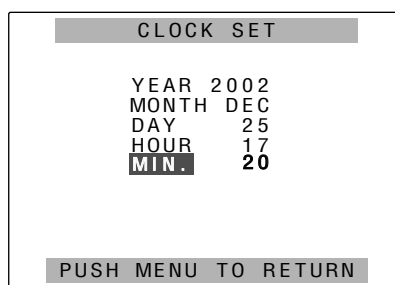

The 24-hour system is used to display the hours.

**8** Press the MENU button three times to release the menu mode.

An error will develop in the time, so check whether the correct time is displayed before shooting.

## Charging the internal battery

---

The date and time are stored in the memory using the internal battery. When the “” display appears in the viewfinder and on the LCD monitor screens, it means that the internal battery has run down.

Recharge it by following the steps below.

Upon completion of charging, reset the date and time.

- 1** Connect the AC adapter to the camera recorder.

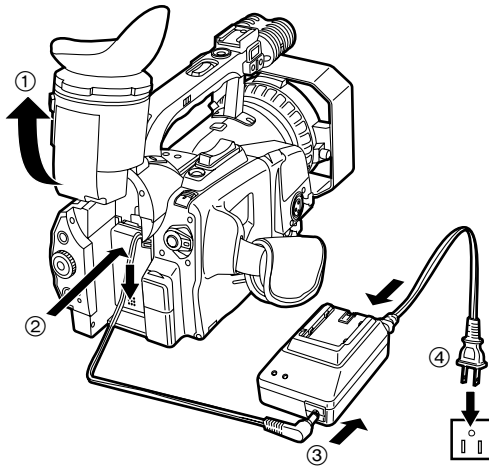

- 2** Return the viewfinder to its original position.
- 3** Leave the camera recorder's POWER switch at the **OFF** position.
- 4** Keep the camera recorder like this for about 4 hours.
  - The internal battery is charged during this time.

# Setting the electronic shutter

## Shutter speeds which can be set

Progressive mode	Standard (OFF) shutter speed	Shutter speeds which can be selected using SPEED SEL button	
		SYNCHRO SCAN	Shutter speed settings
OFF (60i)	1/60	1/60.3 --- 1/250	1/100, 1/120, 1/250, 1/500, 1/1000, 1/2000
30P	1/50	1/30.1 --- 1/250.0	1/30, 1/60, 1/120, 1/250, 1/500, 1/1000
24P/24PA	1/50	1/24.1 --- 1/250.0	1/24, 1/60, 1/120, 1/250, 1/500, 1/1000

**1** Each time the SHUTTER button is pressed, the standard (OFF) shutter speed and the shutter speed selected by the SPEED SEL button are selected alternately.

**2** After pressing the SHUTTER button, press the SPEED SEL button to select the shutter speed. Each time the SPEED SEL button is pressed, the shutter speed changes by one setting in the following sequence.

When the progressive mode is OFF (60i)

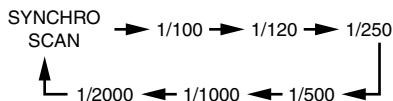

In the progressive mode (30P, 24P or 24PA)

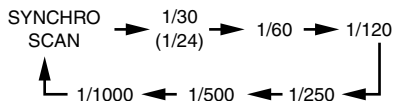

- The higher the shutter speed, the lower the sensitivity of the camera.
- When the iris is controlled automatically, it opens more and more and the depth of focus becomes shallower and shallower as the shutter speed increases.

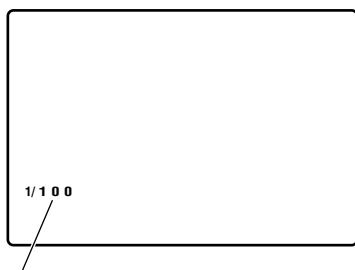

If a setting other than OFF has been selected for the OTHER DISPLAY item on the setting menu DISPLAY SETUP screen, the current shutter speed setting is displayed in the viewfinder and on the LCD monitor. However, it is not displayed if the standard (OFF) shutter speed has been set.

The luminance level of artificial lighting—particularly that of fluorescent lights and mercury lamps—changes in synchronization with the power line frequency. Especially in areas with a power line frequency of 50 Hz, the vertical sync frequency (approx. 60 Hz) of the camera recorder and frequency of the lighting (50 Hz) will interfere with each other, possibly causing the white balance to change cyclically. When shooting under artificial lighting or when adjusting the white balance, set the shutter speed as shown below.

Progressive mode	Shutter speed	
	50 Hz	60 Hz
OFF (60i)	1/100	OFF (1/60)
30P	OFF (1/50)	1/60
24P/24PA	OFF (1/50)	1/60

### Synchro scan

The shutter speed of synchro scan used when shooting TV screens or computer monitor screens is set using the SYNCHRO SCAN item on the setting menu CAMERA SETUP screen. (See page 40)

- When the shutter is adjusted to suit the frequency of a TV screen or computer monitor screen, the horizontal noise that occurs when shooting TV screens is minimized.
- When the progressive mode is set, TV screens which have been played back with the PAL system can be shot as well.

The setting for progressive mode can be switched with the PROGRESSIVE item on the SCENE FILE screen of the setting menu. (See page 39)

# White balance and black balance

## Adjusting the white balance

The white balance must always be re-adjusted when the lighting conditions have changed.

The white balance adjustment values can be stored in the memory at the A and B positions of the WHITE BAL switch.

Use A or B, whichever better suits the shooting conditions concerned.

The 3200K and 5600K white balance values have been stored in the memory at the PRST position of the WHITE BAL switch.

When the AWB button is pressed while the WHITE BAL switch is at the PRST position, the current white balance value is displayed.

When the AWB button is pressed again, the 3200K and 5600K white balance values are selected alternately.

Use 3200K or 5600K, whichever better suits the shooting conditions concerned when, for instance, there is no time to adjust the white balance.

**1** Set the shutter speed.

**2** Place a white pattern in a location subject to the same conditions as the lighting source of the subject, zoom in on it, and fill the whole screen with white.

A white object (white cloth or white wall) near the subject may be used instead of the white pattern.

- Ensure that there are no high-luminance spotlights on the screen.

**3** The WHITE BAL switch can be set to the A or B position and white balance values here can be stored in the memory.

Set the switch to the position (A or B) where the white balance adjustment value is to be stored, and press the AWB button.

- It takes a few seconds to complete the adjustment.

(The following messages appear on the screen.)

Message that appears while adjustment is underway

**AWB Ach ACTIVE**

Message that appears upon completion of the adjustment

**AWB Ach OK**

If it has not been possible to adjust the white balance automatically, an error message appears in the viewfinder and on the LCD monitor screen.

- When the ATW (Auto Tracking White) function is operating, the white balance cannot be adjusted automatically.

Message that appears when adjustment is not possible

**AWB Ach NG**

Error message	Countermeasure
<b>LOW LIGHT</b>	Increase the amount of light. Alternatively, boost the gain.
<b>LEVEL OVER</b>	Reduce the amount of light. Alternatively, lower the gain.

If one of the above error messages has appeared, implement the suggested countermeasure, and then try adjusting the white balance again.

If the error message persists even after repeated attempts at adjustment, consult your dealer.

# White balance and black balance

---

## Adjusting the black balance

There is normally no need to re-adjust the black balance. Adjustment is required only in the following cases.

- When the camera recorder is to be used for the first time
- When the camera recorder is to be used after it has not been used for an extended period
- When the camera recorder is to be used in a situation where the ambient temperature will vary significantly
- When the progressive mode has been switched to the standard (60i) mode or vice versa

### In the standard (60i) mode

The white balance is adjusted automatically by pressing the AWB button.

If the button is then held down, the black balance is adjusted.

### In the progressive mode

By simply pressing the AWB button, the white balance is adjusted automatically, and then the black balance is adjusted.

- When the AWB button is pressed, the white balance is adjusted first. Therefore, ensure that the conditions under which the white balance is adjusted are satisfied before pressing the button.
- While recording is in progress, the black balance cannot be adjusted.

Message that appears while adjustment is underway

**ABB ACTIVE**

Message that appears upon completion of the adjustment

**ABB END**

## ATW (Auto Tracking White) function

The ATW function can be allocated to the WHITE BAL switch (A, B or PRST position) using the ATW item on the setting menu SW MODE screen. (See page 40)

Similarly, the ATW function can be allocated to the AUTO button using the ATW item on the setting menu AUTO SW screen. (See page 41)

When material is shot using the ATW function, it is recorded while the white balance is being continually adjusted automatically.

- The ATW function automatically identifies the shooting environment and adjusts the white balance optimally. In some environments, a slight adjustment error may arise. If an extremely accurate white balance adjustment is required, adjust the white balance by following the instructions on the previous page.

# Setting the time data

## Setting the user's bit

By setting the user's bit, memos (dates, times) and other information consisting of up to 8 digits in hexadecimal notation can be recorded on the sub-code track. The user's bit settings are automatically stored in the memory and retained even after the power has been turned off.

**1** Set the camera recorder's POWER switch to ON.

**2** Select **USER** as the setting for the UB MODE item on the setting menu RECORDING SETUP screen.

- For details on the menu operations, refer to page 37.

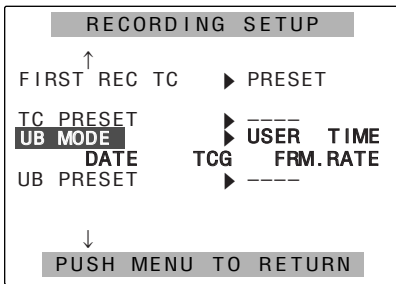

**3** Tilt the OPERATION lever in the ▼ direction and move to the **UB PRESET** item.

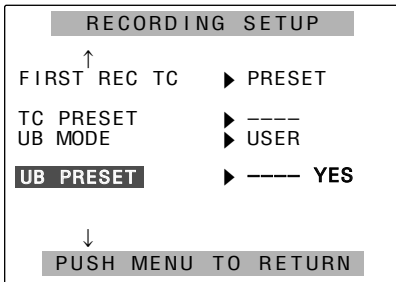

**4** Press "||" of the OPERATION lever, and move "▶" to **YES**.

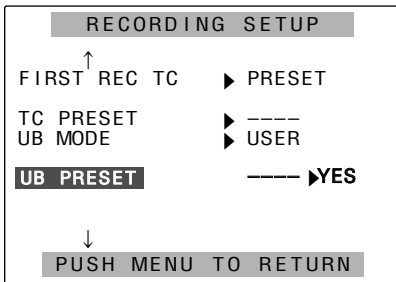

**5** The screen shown below appears. Set the user's bit using the OPERATION lever. Tilt the OPERATION lever in the ▲ or ▼ direction, select the user's bit characters, press "||" of the OPERATION lever, and move to the next digit.

- The numbers 0 to 9 and letters A to F can be used as the user's bit characters.
- When the COUNTER RESET button is pressed on the screen shown below, the user's bit is reset to zero.

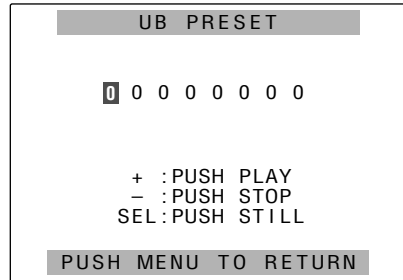

**6** Upon completion of the user's bit setting, press the MENU button. The screen shown below appears. Tilt the OPERATION lever in the ▼ direction, select **YES**, and press "||" of the OPERATION lever.

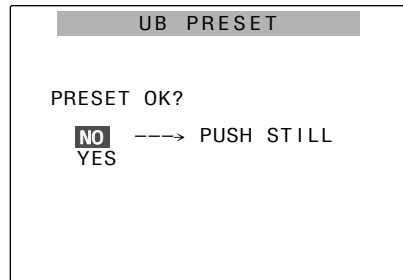

**7** Press the MENU button twice to release the menu mode.



# Setting the time data

## Setting the time code

The various settings related to the time code are performed using the following items on the setting menu RECORDING SETUP screen.

- **TC MODE item**
- **TCG item**
- **FIRST REC TC item**
- **TC PRESET item**
- **1394 TC REGEN item** (appears in the VCR mode)

For further details, refer to page 43.

- When ON has been selected as the setting for the 1394 TC REGEN item in the VCR mode, the settings of the items listed above cannot be changed.

### How to select the TC PRESET item setting

When the time code at the start of the recording is to be recorded using the value specified by the user as its initial value, set the time code value using the TC PRESET item.

**1** Set the camera recorder's POWER switch to ON.

**2** Select **PRESET** as the setting for the FIRST REC TC item on the setting menu RECORDING SETUP screen.

- For details on the menu operations, refer to page 37.

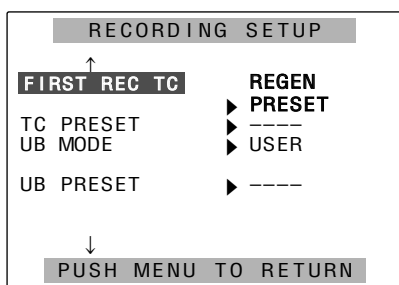

**3** Tilt the OPERATION lever in the ▼ direction and move to the **TC PRESET** item.

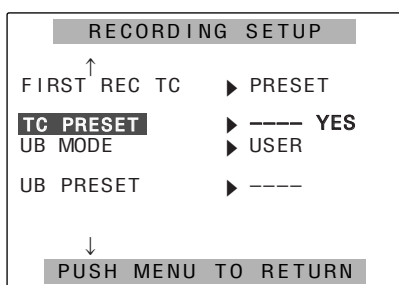

**4** Press "II" of the OPERATION lever, and move "▶" to **YES**.

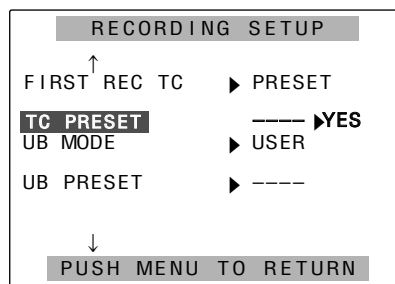

**5** The screen shown below appears. Set the time code value using the OPERATION lever.

Tilt the OPERATION lever in the ▲ or ▼ direction, select the time code value, press "II" of the OPERATION lever, and move to the next digit.

- When the COUNTER RESET button is pressed on the screen shown below, the time code value is reset to zero.

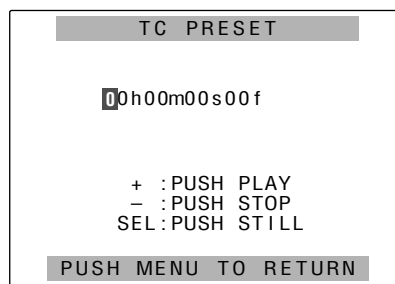

**6** Upon completion of the time code value setting, press the MENU button. The screen shown below appears. Tilt the OPERATION lever in the ▼ direction, select **YES**, and press "II" of the OPERATION lever.

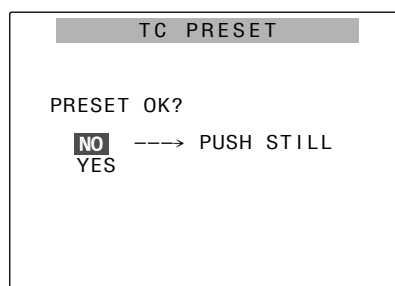

**7** Press the MENU button twice to release the menu mode.

## Scene files

---

The settings selected to suit various shooting situations are stored in the positions of the scene file dial. During shooting, the required file can be read out in an instant using this dial.

The following files were stored as factory settings prior to shipment.

- Even when a scene file has been changed during recording, the progressive mode will not be changed.  
To change this mode, establish the recording standby mode.

### **F1: SCENE**

File containing the settings suited to standard shooting

### **F2: SCENE FLOU.**

File containing the settings suited to shooting where consideration is given to the characteristics of fluorescent lights (for shooting indoors, etc.)

### **F3: SCENE SPARK**

File containing the settings suited to shooting for accentuating the subjects (for shooting wedding receptions, etc.)

### **F4: SCENE B-STR**

File containing the settings suited to shooting with extended gradations for the dark areas (for shooting scenes at dusk, etc.)

### **F5: SCENE 24P**

File containing the settings suited to shooting in the progressive 24P mode

### **F6: SCENE ADVANC**

File for the progressive 24P advanced mode

# Scene files

## Changing the scene file settings

Scene file settings can be changed.

In addition, scene files in which changes have been made can be stored in the positions of the scene file dial.

**1** Set the camera recorder's POWER switch to ON.

**2** Turn the scene file dial, and select the scene file in which changes are to be made.

**3** Change the item on the setting menu SCENE FILE screen.

- For details on the menu operations, refer to page 37.

**4** Tilt the OPERATION lever in the ▼ direction and move to the **NAME EDIT** item.

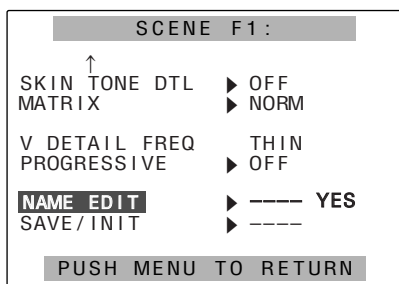

**5** Press “II” of the OPERATION lever, and move “▶” to **YES**.

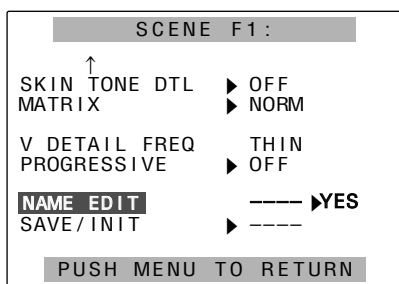

**6** The screen shown below appears. Set a filename consisting of six characters using the OPERATION lever.

- Characters which can be set  
□ (space), letters A to Z, numbers 0 to 9, :, ;, <, =, >, ?, @, [, ¥, ], ^, \_

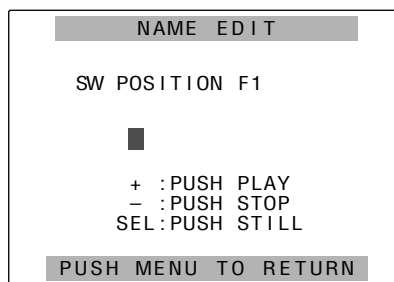

**7** Upon completion of the filename setting, press the MENU button.

**8** Tilt the OPERATION lever in the ▼ direction and move to the **SAVE/INIT** item.

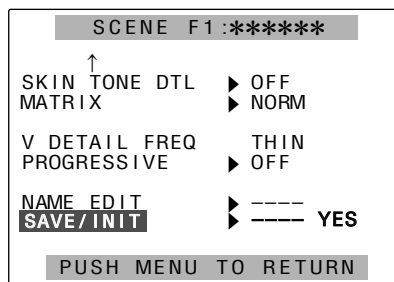

**9** Press “II” of the OPERATION lever, and move “▶” to **YES**.

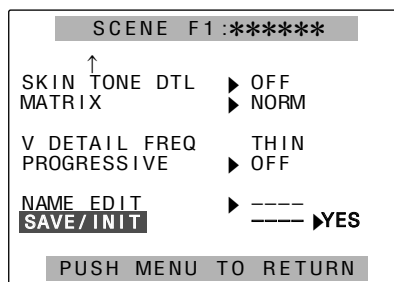

# Scene files

- 10** The screen shown below appears. Press “**II**” of the OPERATION lever, and move “**▶**” to **YES**.

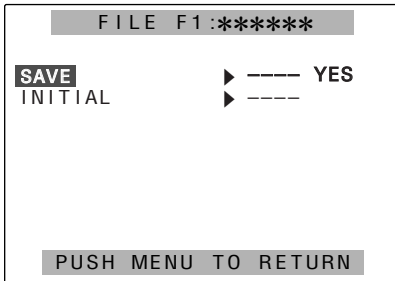

To return the scene file settings to the factory settings, select **INITIAL** in step **10**, and then perform the same steps **11** to **13**.

- 11** The screen shown below appears. Tilt the OPERATION lever in the ▼ direction, select YES, and press “**II**” of the OPERATION lever.

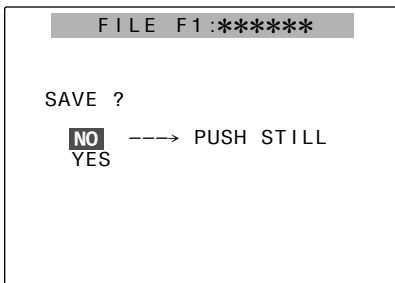

- 12** A beep sounds ten times in succession, the following message appears, and the scene file changes are completed.



- 13** Press the MENU button three times to release the menu mode.

If the menu mode is released without saving the changes, the original scene file settings will be restored when operation is switched to the VCR mode or the power is turned off.

# Setting menus

The camera recorder's settings can be changed to suit the scenes to be shot or what is to be recorded using the setting menus.

## Operation method

**1** In any operation mode except the shooting mode or recording mode, press the MENU button.

The menu mode is established, and the function screen shown below appears in the viewfinder and on the LCD monitor.

[Camera mode]

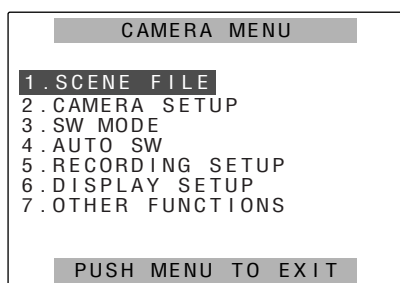

[VCR mode]

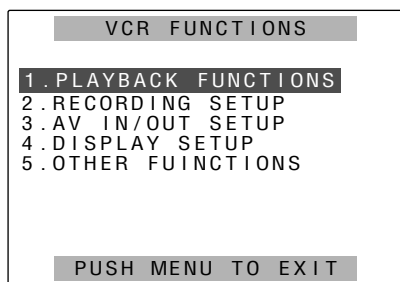

**2** Tilt the OPERATION lever in the ▲ or ▼ direction, and move the highlighted part to the function which is to be set.

(If the remote control unit is used, press the “▲” or “▼” button among the SET buttons.)

**3** Press “II” of the OPERATION lever, and display the setting item.

(If the remote control unit is used, press the “▶” button among the SET buttons.)

Example:

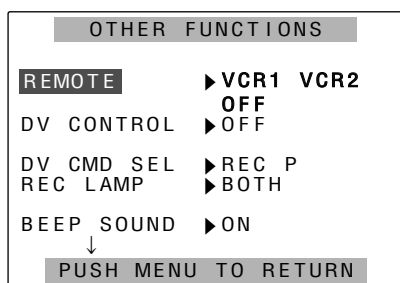

**4** Tilt the OPERATION lever in the ▲ or ▼ direction, and move the highlighted part to the function which is to be set.

(If the remote control unit is used, press the “▲” or “▼” button among the SET buttons.)

Example:

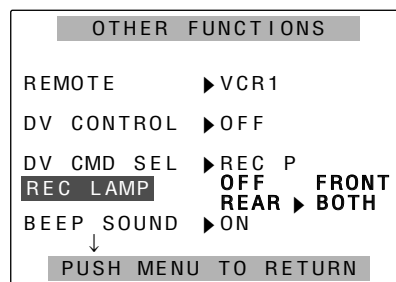

**5** Press “II” of the OPERATION lever, and move “▶” to the setting which is to be changed.

(If the remote control unit is used, press the “▶” button among the SET buttons.)

To change a numerical value, for example, move “▶” to the position of the value to be changed, tilt the OPERATION lever in the ▲ or ▼ direction, and change the setting.

(If the remote control unit is used, press the “▲” or “▼” button among the SET buttons.)

Example:

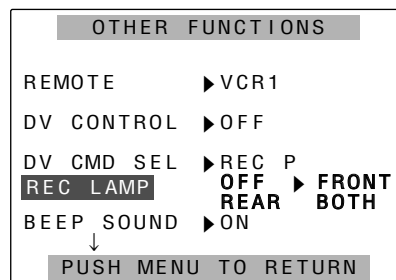

**6** To change another item, repeat steps 4 and 5.

To exit the settings, press the MENU button to return to the function screen.

**7** To change another function, repeat steps 2 to 5.

To exit the menu mode, press the MENU button to return to the normal screen.

# Setting menus

## Configuration of setting menus

### Menus in the camera mode

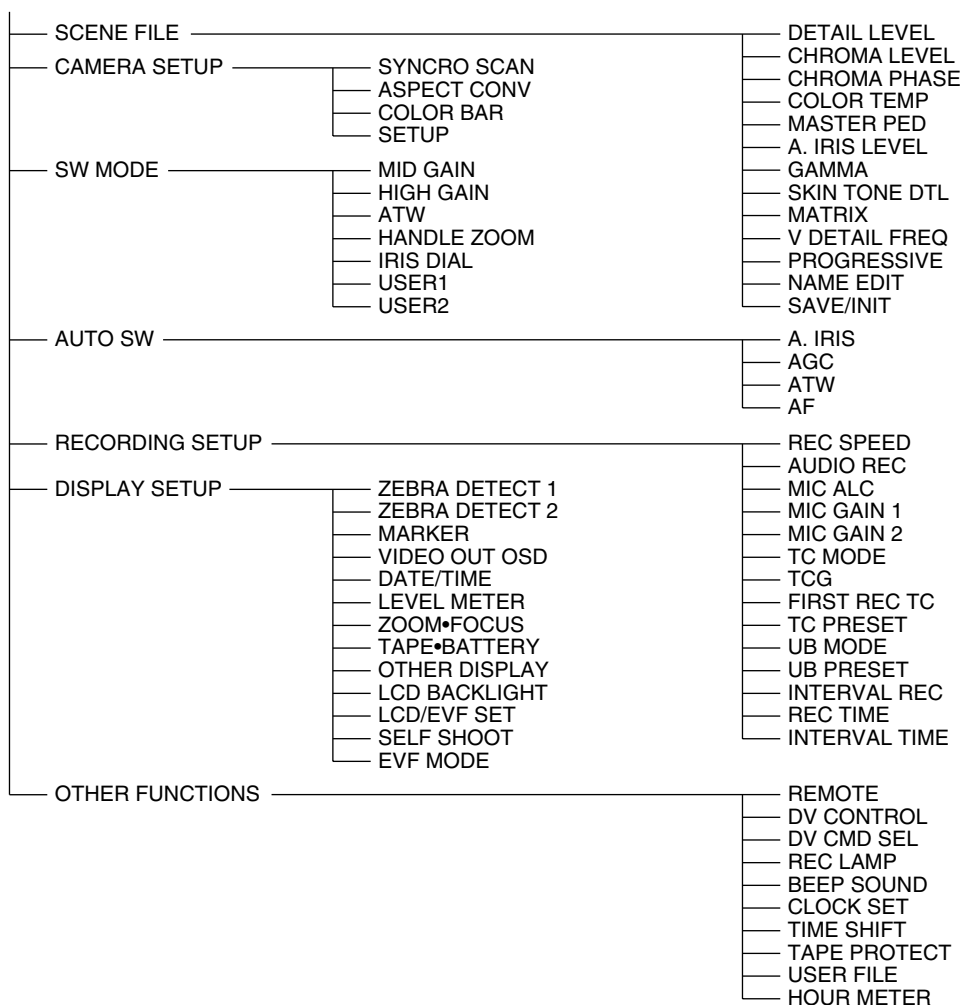

### Menus in the VCR mode

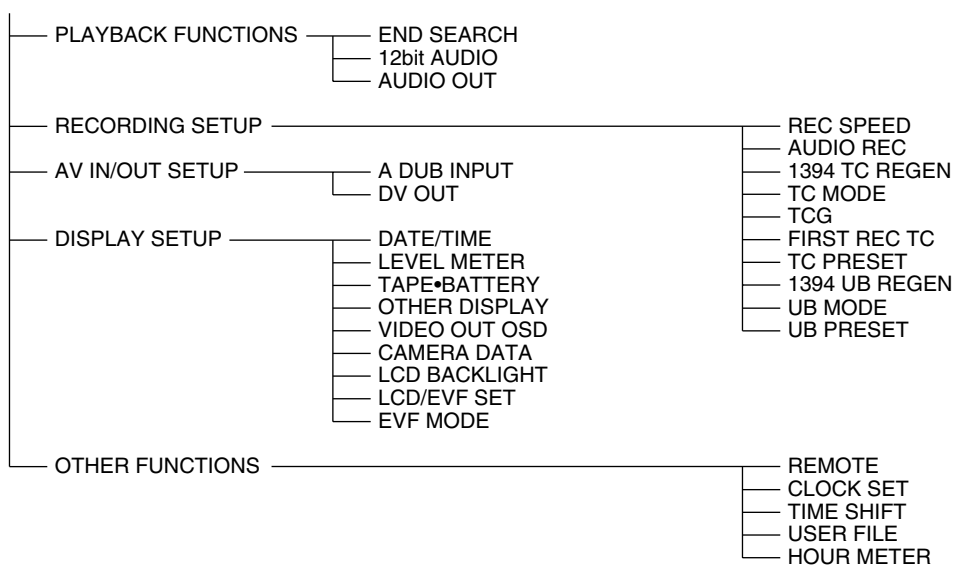

# Setting menus

## SCENE FILE screen

Item/ (display mode)	Description of settings
DETAIL LEVEL (Camera)	For adjusting the detail amount. -7 --- 0 --- +7
CHROMA LEVEL (Camera)	For adjusting the chroma level. -7 --- 0 --- +7
CHROMA PHASE (Camera)	For finely adjusting the chroma phase. -7 --- 0 --- +7
COLOR TEMP (Camera)	For finely adjusting the color temperature (for performing fine adjustments after the white balance has been adjusted). -7 --- 0 --- +7
MASTER PED (Camera)	For adjusting the black master pedestal which serves as the video reference. -15 --- 0 --- +15
A. IRIS LEVEL (Camera)	For setting the auto iris target value. -4 --- 0 --- +4
GAMMA (Camera)	For selecting the gamma curve. <b>CINE-LIKE:</b> The gamma curve which gives the images a cinema-like finish is used. In order to make full use of the CINE- LIKE gamma characteristics, it is recommended that the lens iris be set lower (by approx. 1/2) than the regular video level. <b>LOW:</b> Using a gamma curve with a moderate gradient for the low-luminance areas, the images are given a calm, composed look. A sharp touch is conveyed by the contrast. <b>NORM:</b> Standard images are produced. <b>HIGH:</b> Using a gamma curve with a sharp gradient for the low-luminance areas, the gradations of the dark areas are extended to make them appear brighter. A soft touch is conveyed by the contrast.
SKIN TONE DTL (Camera)	For switching the skin tone detail ON or OFF. When ON is selected, the detail in the skin tone areas is diminished and the graininess of the skin is reduced. <b>OFF    ON</b>
MATRIX (Camera)	For selecting the matrix table and expressing the colors during shooting. <b>NORM:</b> Colors suited to shooting outdoors or under light sources using halogen lamps are expressed. <b>FLOU:</b> Colors suited to shooting indoors under fluorescent light sources are expressed. <b>CINE-LIKE:</b> Colors suited to cinema-like shooting are expressed.

Item/ (display mode)	Description of settings
V DETAIL FREQ (Camera)	For setting the detail in the vertical direction when shooting in the progressive mode. <b>THIN</b> : The detail is made finer. <b>THICK</b> : The detail is made coarser. ● When "THIN" has been selected as the item's setting and the images shot in the progressive mode are played back using a standard TV monitor (60i: interlace), some flickering will occur on the horizontal lines and on the diagonal lines near the horizontal. When playing back a tape in a progressive environment, this flickering is reduced by selecting "THIN" as the item's setting, which will also enable images with a higher resolution than that with the "THICK" setting to be obtained.
PROGRESSIVE (Camera)	For setting shooting in the progressive mode. <b>OFF:</b> Shooting is not performed in the progressive mode. <b>30P:</b> Shooting is performed in the 30P mode (30 frames/sec.). <b>24P:</b> Shooting is performed in the 24P mode (24 frames/sec.). Images are recorded on the tape using the [2:3] conversion system. <b>24P(ADV):</b> Shooting is performed in the 24P advanced mode (24 frames/sec.). Images are recorded on the tape using the advanced conversion system.
NAME EDIT (Camera)	For editing the name of the scene file selected by the scene file dial.
SAVE/INIT (Camera)	<b>SAVE:</b> For saving the scene file settings after changes have been made to them. ● If the menu mode is released without saving the changes, the original scene file settings will be restored when operation is switched to the VCR mode or the power is turned off. <b>INITIAL:</b> For returning the scene file settings selected by the scene file dial to the factory settings.

# Setting menus

## CAMERA SETUP screen

Item/ (display mode)	Description of settings
SYNCHRO SCAN (Camera)	For adjusting the shutter speed of synchro scan used when shooting TV screens, etc. If the OPERATION lever is left tilted in the ▲ or ▼ direction, the speed at which the setting changes is increased, and a beep is heard. <ul style="list-style-type: none"> <li>● <b>Progressive mode OFF:</b> 1/60.3 --- 1/250.0</li> <li>● <b>Progressive mode 30P:</b> 1/30.1 --- 1/48.0 --- 1/250.0</li> <li>● <b>Progressive mode 24P or 24PA:</b> 1/24.1 --- 1/48.0 --- 1/250.0</li> </ul>
ASPECT CONV (Camera)	For selecting the aspect ratio of the images to be recorded. <b>NORM:</b> The images are recorded in the standard 4:3 mode. <b>LETTER BOX:</b> The aspect ratio is set to the 16:9 mode, and the images are recorded in this mode. Black bands are recorded at the top and bottom of the screen.
COLOR BAR (Camera)	For setting the color bar display to ON or OFF. (Color bars are not displayed in the progressive mode.) <b>OFF ON</b> ● Even when the color bar display has been set to ON, it will return to OFF when operation is switched to the VCR mode or the power is turned off.
SETUP (Camera)	For setting whether to add the setup level (black level). <b>0%:</b> The setup level is not added. <b>7.5%:</b> The 7.5% setup level is added for recording.

## SW MODE screen

Item/ (display mode)	Description of settings
MID GAIN (Camera)	For setting the gain value which is to be allocated to the M position of the GAIN switch. <b>0 dB, 3 dB, 6 dB, 9 dB, 12 dB</b>
HIGH GAIN (Camera)	For setting the gain value which is to be allocated to the H position of the GAIN switch. <b>0 dB, 3 dB, 6 dB, 9 dB, 12 dB</b>
ATW (Camera)	For setting the ATW (Auto Tracking White) function which is to be allocated to the WHITE BAL switch. <b>OFF:</b> The ATW function is not activated. However, if it has been set in the AUTO button or USER button, it will follow the operation of the button concerned. <b>Ach:</b> The ATW function is activated when the WHITE BAL switch has been set to the A position. <b>Bch:</b> The ATW function is activated when the WHITE BAL switch has been set to the B position. <b>PRE:</b> The ATW function is activated when the WHITE BAL switch has been set to the PRST position.
HANDLE ZOOM (Camera)	For setting the zoom speeds which are to be allocated to the positions of the HANDLE ZOOM switch. <b>L/OFF/H:</b> LOW/OFF/HIGH are set to the 1/2/3 positions. (At OFF, no zoom operations are performed.) <b>L/M/H:</b> LOW/MID/HIGH are set to the 1/2/3 positions.
IRIS DIAL (Camera)	For setting the rotational direction of the IRIS dial and iris control (in the MANUAL IRIS mode). <b>DOWN OPEN:</b> The iris opens when the IRIS dial is turned downward. <b>UP OPEN:</b> The iris opens when the IRIS dial is turned upward.

The underlining indicates the factory setting.



# Setting menus

## SW MODE screen

Item/ (display mode)	Description of settings
<b>USER1</b> (Camera)	<p>For setting the operation of the function allocated to the USER1 button.</p> <p><b>COLOR BAR:</b> The color bar display is set to ON or OFF.</p> <p><b>SPOTLIGHT:</b> The auto iris control for the spotlight is set to ON or OFF.</p> <p><b>BACKLIGHT:</b> The auto iris control for backlight compensation is set to ON or OFF.</p> <p><b>BLACKFADE:</b> When the button is held down, the whole image is faded out into black. The sound is also faded out at the same time.</p> <p><b>WHITEFADE:</b> When the button is held down, the whole image is faded out into white. The sound is also faded out out at the same time.</p> <p><b>MODECHECK:</b> When the button is pressed, the camera status currently set is displayed in the viewfinder and on the LCD monitor where it can be checked.</p> <p><b>ATW:</b> The operation of the ATW function is set to ON or OFF.</p> <p><b>ATWLOCK:</b> When the button is pressed, the white balance value is fixed; when it is pressed again, the operation of the ATW function is performed.</p> <p><b>GAIN:18 dB:</b> When this button is pressed, the gain is set to 18 dB.</p> <ul style="list-style-type: none"> <li>• The picture may be temporarily disturbed when the gain has been switched to 18 dB or from 18 dB to another value.</li> </ul>
<b>USER2</b> (Camera)	<p>For setting the operation of the function to be allocated to the USER2 button. The settings are the same as for the ones for the USER1 items.</p> <p><b>BACKLIGHT</b></p>

## AUTO SW screen

Item/ (display mode)	Description of settings
<b>A. IRIS</b> (Camera)	<p><b>ON:</b> When the AUTO button is pressed, the auto iris control operation is performed. The IRIS button does not work at this time.</p> <p><b>OFF:</b> The auto iris control operation is not performed even if the AUTO button is pressed. The iris control operation selected by the IRIS button is performed.</p>
<b>AGC</b> (Camera)	<p>For setting the auto gain control operation when ON is selected as the A. IRIS item setting.</p> <p><b>6 dB:</b> Auto gain control up to 6 dB is performed when the AUTO button is pressed.</p> <p><b>12 dB:</b> Auto gain control up to 12 dB is performed when the AUTO button is pressed.</p> <p><b>OFF:</b> Auto gain control is not performed even if the AUTO button is pressed.</p>
<b>ATW</b> (Camera)	<p><b>ON:</b> The ATW (auto tracking white balance) function operation is set to ON or OFF using the AUTO button. At this time, the operation of this function cannot be set to ON or OFF using the WHITE BAL switch and USER button. However, when ATWLOCK is allocated to the USER button, the white balance value can be fixed using the USER button.</p> <p><b>OFF:</b> The ATW function operation is not performed even if the AUTO button is pressed. The ATW function operation selected by the WHITE BAL switch is performed.</p>
<b>AF</b> (Camera)	<p><b>ON:</b> When the AUTO button has been pressed, the auto focus operation is performed. The FOCUS switch and PUSH AUTO button do not work at this time.</p> <p><b>OFF:</b> The auto focus operation is not performed even if the AUTO button is pressed. The focus operation selected by the FOCUS switch and PUSH AUTO button is performed.</p>

The underlining indicates the factory setting.

# Setting menus

## PLAYBACK FUNCTIONS screen

Item/ (display mode)	Description of settings
END SEARCH (VCR)	For setting what kind of operation is to be performed when the END SEARCH button is pressed. <b>BLANK:</b> The unrecorded blanks on the video tape are searched. <b>REC END:</b> The part which was shot last is searched. <b>&lt;Notes&gt;</b> <ul style="list-style-type: none"> <li>● Even when the REC END setting is selected, the part which was shot last will not be searched when the tape is switched.</li> <li>● If nothing has been recorded on the tape, operation will stop at the end of the tape.</li> <li>● END SEARCH may not operate properly if there is an unrecorded blank near the tape start or at a point along the tape.</li> </ul>

### Inputs and audio tracks recorded

Input	When shooting	When audio dubbing (12-bit mode)
Internal microphone L	CH1	CH3
Internal microphone R	CH2	CH4
INPUT 1 (XLR)	CH1	CH3
INPUT 2 (XLR)	CH2 (CH1)	CH4 (CH3)
AUDIO IN/OUT CH1 (pin jack)	—	CH3
AUDIO IN/OUT CH2 (pin jack)	—	CH4

The audio tracks on which signals are to be recorded during shooting can be changed using the CH1 SELECT switch and CH2 SELECT switch.

The audio tracks on which signals are to be recorded during audio dubbing can be changed using the A DUB INPUT item on the AV IN/OUT SETUP screen.

### 12-bit AUDIO item and AUDIO OUT item settings, and audio tracks whose signals are output from the AUDIO IN/OUT connectors (pin jacks)

Audio recording mode	12-bit AUDIO item setting	AUDIO OUT item setting	AUDIO IN/OUT CH1 output	AUDIO IN/OUT CH2 output
12 bit	ST1	CH1•CH2 CH1 CH2	CH1 CH1 CH2	CH2 CH1 CH2
	ST2	CH1•CH2 CH1 CH2	CH3 CH3 CH4	CH4 CH3 CH4
	MIX	—	CH1+CH3	CH2+CH4
16 bit	—	CH1•CH2 CH1 CH2	CH1 CH1 CH2	CH2 CH1 CH2

The underlining indicates the factory setting.

Item/ (display mode)	Description of settings
12bit AUDIO (VCR)	For setting the sound to be output as the CH1 and CH2 signals when a tape recorded in the 12-bit audio mode is played back. <b>ST1:</b> The sound recorded during shooting is selected. CH1 signals = CH1 track CH2 signals = CH2 track <b>ST2:</b> The sound recorded during audio dubbing is selected. CH1 signals = CH3 track CH2 signals = CH4 track <b>MIX:</b> The sound recorded during shooting and the sound recorded during audio dubbing are mixed. CH1 signals = CH1 + CH3 tracks CH2 signals = CH2 + CH4 tracks <b>&lt;Note&gt;</b> If the sound has been recorded in the 16-bit mode, there is no CH3 or CH4. Therefore, the correlation between the signals and tracks will always be as follows: CH1 signals = CH1 track CH2 signals = CH2 track
AUDIO OUT (VCR)	For setting the audio signals to be output from the AUDIO IN/OUT connectors (pin jacks) when a tape is played back. <b>CH1•CH2:</b> CH1 connector = CH1 signals CH2 connector = CH2 signals <b>CH1:</b> CH1 connector = CH1 signals CH2 connector = CH1 signals <b>CH2:</b> CH1 connector = CH2 signals CH2 connector = CH2 signals

# Setting menus

## RECORDING SETUP screen

Item/ (display mode)	Description of settings
REC SPEED (Camera) (VCR)	For selecting the recording time mode. <u>SP</u> : SP (standard play) mode LP: LP (long play) mode
AUDIO REC (Camera) (VCR)	For selecting the system for converting the recording to PCM audio. 12 bit : 12-bit/32kHz <u>16 bit</u> : 16-bit/48kHz
MIC ALC (Camera)	For setting the mic level automatic control function to ON or OFF. <u>OFF</u> <u>ON</u> Audio distortion caused by excessively high input level can be minimized by selecting ON for this item. <ul style="list-style-type: none"> <li>The recording level of the audio signals must be adjusted using the AUDIO controls, irrespective of this setting.</li> </ul>
MIC GAIN 1 (Camera)	For setting the input level of the external microphone which is connected to the INPUT 1 connector. <u>-50 dB</u> -60 dB
MIC GAIN 2 (Camera)	For setting the input level of the external microphone which is connected to the INPUT 2 connector. <u>-50 dB</u> -60 dB
1394 TC REGEN (VCR)	For selecting the time code to be recorded when recording the signals of a component connected to the DV connector. <u>OFF</u> : The signals are recorded using the time code which was set using the TC MODE item, TCG item and FIRST REC TC item. <u>ON</u> : The signals are recorded using the time code of the signals which have been input to the DV connector. <ul style="list-style-type: none"> <li>When ON has been selected as this item's setting, this setting takes precedence over the TC MODE item, TCG item and FIRST REC TC item settings.</li> <li>When no signals are supplied to the DV connector, the TC MODE item, TCG item and FIRST REC TC item settings are followed.</li> </ul>
TC MODE (Camera) (VCR)	For selecting the time code correction mode in which the time code of the internal time code generator is to be recorded. <u>DF</u> : The drop frame mode is used. NDF : The non-drop frame mode is used. <ul style="list-style-type: none"> <li>When the progressive mode has been set to 24P or 24P (ADV), the non-drop frame mode is established regardless of this item's setting.</li> </ul>

Item/ (display mode)	Description of settings
TCG (Camera) (VCR)	For setting the operation mode in which the internal time code generator is to be run. <u>FREE RUN</u> : The internal time code generator is run regardless of the operation mode. <u>REC RUN</u> : The internal time code generator is run during recording.
FIRST REC TC (Camera) (VCR)	For selecting the time code which is to be recorded when recording is started. <u>REGEN</u> : Recording proceeds in such a way that the time code continues on (is regenerated) from the time code on the tape. <u>PRESET</u> : The time code is not regenerated from the time code on the tape. The time code is recorded using the value set in the TC PRESET item serving as the initial value. However, the time code is forcibly regenerated when shooting with frame-to-frame continuity has been performed.
TC PRESET (Camera) (VCR)	For setting the initial value of the time code to be recorded. This item's setting is valid when PRESET has been selected as the setting for the FIRST REC TC item. <ul style="list-style-type: none"> <li>When the progressive mode has been set to 24P or 24P (ADV), set the frame value to 0 or to a multiple of 5. If any other value is set, the time code recorded will shift.</li> </ul>
1394 UB REGEN (VCR)	For selecting the user's bit to be recorded when recording the signals of the component connected to the DV connector. <u>OFF</u> : The user's bit selected for the UB MODE item is used for the recording. <u>ON</u> : The user's bit of the signals input to the DV connector is used for the recording. <ul style="list-style-type: none"> <li>When ON has been selected as this item's setting, this setting takes precedence over the UB MODE item setting.</li> <li>The user's bit is not recorded if the signals do not contain the user's bit information.</li> <li>When no signals are supplied to the DV connector, the UB MODE item setting is followed.</li> </ul>

The underlining indicates the factory setting.

# Setting menus

## RECORDING SETUP screen

Item/ (display mode)	Description of settings
UB MODE (Camera) (VCR)	<p>For setting what is to be recorded as the user's bit.</p> <p><b>USER:</b> The user's information is recorded.</p> <p><b>TIME:</b> The time of the recording is recorded.</p> <p><b>DATE:</b> The date of the recording is recorded.</p> <p><b>TCG:</b> The time code generator's value is recorded.</p> <p><b>FRM. RATE:</b> The frame rate information for frame conversion is recorded.</p> <p><u>** 0* ** *</u></p> <p><b>Recording control information</b></p> <ul style="list-style-type: none"> <li>• Updated frame information</li> <li>• REC START/STOP information</li> </ul> <p><b>Frame rate information</b></p> <ul style="list-style-type: none"> <li>• Frame rate (60, 30 or 24)</li> <li>• I/P identification information</li> <li>• Conversion information</li> <li>• Frame rate coefficient</li> </ul> <p><b>Frame sequence number</b></p> <ul style="list-style-type: none"> <li>• A number from 0 to 4 is displayed in the 24P or 24P (ADV) mode.</li> <li>• "F" is displayed in the 60 or 30P mode.</li> </ul> <p><b>User's bit value verification information</b></p>
UB PRESET (Camera) (VCR)	For setting the user's bit. However, USER must be selected for the UB MODE item setting.

Item/ (display mode)	Description of settings
INTERVAL REC (Camera)	<p>For setting the intermittent recording mode.</p> <p><b>OFF:</b> Intermittent recording is not performed.</p> <p><b>ON:</b> When the START/STOP button is pressed, intermittent recording is performed with the cycle set by the REC TIME item and INTERVAL TIME item.</p> <p><b>ONE-SHOT:</b> The time lapse shooting mode is established.</p> <p>When the START/STOP button is pressed, recording is performed for the number of seconds set by the REC TIME item, after which the recording pause mode is established.</p> <ul style="list-style-type: none"> <li>• When intermittent recording is set to ON or ONE-SHOT, "I -" flashes on the left of the VCR operation mode. When recording is started, it stops flashing and lights.</li> <li>• Even when intermittent recording is set to ON or ONE-SHOT, the intermittent recording mode returns to OFF when the power is turned off.</li> <li>• When the progressive mode has been set to 24P or 24P (ADV), the OFF is established regardless of this item's setting.</li> </ul>
REC TIME (Camera)	<p>For setting the recording duration for which intermittent recording is to be performed.</p> <p><u>0.5s</u> : 0.5 sec.    1s : 1.0 sec. 1.5s : 1.5 sec.    2s : 2.0 sec.</p>
INTERVAL TIME (Camera)	<p>For setting the duration of the interval time with which intermittent recording is to be performed.</p> <p><u>30s</u> : 30 sec.    1m : 1 min. 5m : 5 min.    10m : 10 min.</p>

## AV IN/OUT SETUP screen

Item/ (display mode)	Description of settings
A DUB INPUT (VCR)	<p>For selecting the sound which is to be recorded when audio dubbing is performed.</p> <p><b>MIC:</b> The sound from the internal microphone or the sound from the external components connected to the INPUT 1 and 2 connectors is recorded. (The sound is selected using the CH1 SELECT switch and CH2 SELECT switch.)</p> <p><b>A_IN:</b> The sound of the audio component connected to the AUDIO IN/OUT connectors (pin jacks) is recorded.</p> <p><b>&lt;Note&gt;</b> If audio dubbing is performed when the sound has been recorded in the 16-bit audio mode, the sound will be recorded over the sound heard during shooting.</p>
DV OUT (VCR)	<p>For setting the function, which converts the analog signals which have been input into digital signals and outputs them from the DV connector, to ON or OFF.</p> <p><u>OFF</u>    ON</p>

The underlining indicates the factory setting.

# Setting menus

## DISPLAY SETUP screen

Item/ (display mode)	Description of settings
ZEBRA DETECT 1 (Camera)	For setting the level of the zebra pattern leaning to the left and displayed in the viewfinder and on the LCD monitor. <u>80%</u> , 85%, 90%, 95%, 100%
ZEBRA DETECT 2 (Camera)	For setting the level of the zebra pattern leaning to the right and displayed in the viewfinder and on the LCD monitor. 80%, 85%, 90%, 95%, <u>100%</u> , OFF <Note> When OFF has been set, the zebra pattern is not displayed.
MARKER (Camera)	For switching display of the marker ON/OFF. <u>ON</u> OFF  <ul style="list-style-type: none"> <li>When ON is set, the marker can be displayed by pressing the ZEBRA button.</li> </ul> When the marker is displayed, the video level of the image near the center of the screen is displayed as a percentage value at the bottom left of the screen.
VIDEO OUT OSD (Camera) (VCR)	When ON is set, the information displayed in the viewfinder and on the LCD monitor is output as the video output signal together with the images. <u>ON</u> OFF
DATE/TIME (Camera) (VCR)	For setting the date and/or time to be displayed in the viewfinder, on the LCD monitor and in the video output signals. <b>OFF:</b> The date and time are not displayed. <b>TIME:</b> The time is displayed. <b>DATE:</b> The date is displayed. <b>TIME&amp;DATE:</b> Both the date and time are displayed. <ul style="list-style-type: none"> <li>When a setting other than OFF is selected, the date and/or time are displayed in the video output signals regardless of the setting selected for the VIDEO OUT OSD item.</li> </ul>
LEVEL METER (Camera) (VCR)	For setting the audio level meter display to ON or OFF. OFF <u>ON</u>
ZOOM•FOCUS (Camera)	For setting the zoom and focus value displays to ON or OFF. OFF <u>ON</u>
TAPE•BATTERY (Camera) (VCR)	For setting the remaining tape amount and remaining battery charge displays to ON or OFF. OFF <u>ON</u>
OTHER DISPLAY (Camera) (VCR)	For setting the amount of information to be displayed in the viewfinder and on the LCD monitor. (See page 53) <u>OFF</u> , PARTIAL, ALL

Item/ (display mode)	Description of settings
CAMERA DATA (VCR)	When ON is set, the camera information (such as camera shake correction, iris value and gain value) is displayed when the tape is played back. OFF <u>ON</u>
LCD BACKLIGHT (Camera) (VCR)	For adjusting the backlight of the LCD monitor. When HI is set, the monitor becomes brighter than usual. HI <u>NORMAL</u>
LCD/EVF SET (Camera) (VCR)	For adjusting the display level of the viewfinder and LCD monitor images. <b>LCD BRIGHTNESS:</b> The brightness of the LCD monitor's images is adjusted. <b>LCD COLOR LEVEL:</b> The color level of the LCD monitor's images is adjusted. <b>EVF BRIGHTNESS:</b> The brightness of the viewfinder's images is adjusted.
SELF SHOOT (Camera)	For selecting the LCD monitor's mirror function for face-to-face shooting. When MIRROR is set, the image on the LCD monitor is reversed at the left and right for display during face-to-face shooting. <u>NORMAL</u> <u>MIRROR</u>
EVF MODE (Camera) (VCR)	For selecting what is to be displayed in the viewfinder and on the LCD monitor. <u>ON</u> Images are shown at all times in the viewfinder. <b>AUTO:</b> When the LCD monitor is opened, the images no longer appear in the viewfinder.

The underlining indicates the factory setting.

# Setting menus

## OTHER FUNCTIONS screen

Item/ (display mode)	Description of settings
<b>REMOTE</b> (Camera) (VCR)	For setting the operations which are performed using the accessory wireless remote control unit. (See page 20 for the remote control unit settings.) <b>VCR1:</b> The operation performed by the remote control unit which has been set to be used for VCR1 are accepted. <b>VCR2:</b> The operation performed by the remote control unit which has been set to be used for VCR2 are accepted. <b>OFF:</b> Operations performed by the remote control unit are not accepted.
<b>DV CONTROL</b> (Camera)	For setting the control method when backup shooting is to be performed by connecting a component for backup purposes to the DV connector. <b>OFF:</b> The component for backup purposes is not controlled. <b>EXT:</b> The component for backup purposes is controlled using the START/STOP button on the camera recorder. The images shot by the camera recorder are recorded by the component for backup purposes. However, the camera recorder does not record the images. <b>BOTH:</b> The images shot by the camera recorder are recorded by both camera recorder and the component for backup purposes. <b>CHAIN:</b> When the tape in the camera recorder approaches the end during shooting, recording is automatically commenced by the component for backup purposes, which has been set to the recording standby mode.
<b>DV CMD SEL</b> (Camera)	For setting the recording operation to be performed by the component for backup purposes when the START/STOP button on the camera recorder has been pressed. <b>REC_P:</b> The mode is switched between recording and recording pause. <b>STOP:</b> The mode is switched between recording and stop. <b>&lt;Note&gt;</b> Select STOP as the item's setting if the component for backup purposes is not equipped with a recording pause function.
<b>REC LAMP</b> (Camera)	For setting the lighting of the tally lamps. <b>OFF:</b> The tally lamps do not light. <b>FRONT:</b> The front tally lamp (by the microphone) lights. <b>REAR:</b> The rear tally lamp (by the viewfinder) lights. <b>BOTH:</b> Both the front and rear tally lamps light.

Item/ (display mode)	Description of settings
<b>BEEP SOUND</b> (Camera)	For setting the beep tone to ON or OFF. <b>OFF</b> <b>ON</b>  When ON is selected as the setting, the beep tone is sounded at the times given below. <ul style="list-style-type: none"> <li>When the beep tone is sounded, the audio signals from the output connectors are muted, and the beep tone is output instead.</li> </ul> <b>[Beep tone sounds once]</b> <ul style="list-style-type: none"> <li>When the POWER switch has been set to ON</li> <li>When shooting has commenced</li> </ul> <b>[Beep tone sounds twice]</b> <ul style="list-style-type: none"> <li>When shooting has been temporarily stopped</li> </ul> <b>[Beep tone sounds 10 times]</b> <ul style="list-style-type: none"> <li>When the cassette tape has not been inserted</li> <li>When the cassette tape is in the recording pause mode</li> <li>When condensation has formed inside the camera recorder</li> <li>When a problem has occurred in the camera recorder</li> </ul>
<b>CLOCK SET</b> (Camera) (VCR)	For setting the internal calendar of the camera recorder.
<b>TIME SHIFT</b> (Camera) (VCR)	For adding the time which was set using this item to the time of the internal calendar (to compensate for time differences) for display in the viewfinder and on the LCD monitor. The clock time after the compensation is also recorded on the tape. <b>+23h --- +1h, OFF, -1h --- -23h</b> (In 1-hour increments)
<b>TAPE PROTECT</b> (Camera)	When the camera recorder is left on standby for about 5 minutes in the shooting pause mode, it is automatically set to the tape protection mode. Which tape protection mode is to be established is selected using this item. <b>POWEROFF:</b> The camera recorder's power is set to the OFF mode. <b>STBY:</b> The cylinder head is set to the stop mode.
<b>USER FILE</b> (Camera) (VCR)	<b>LOAD:</b> The settings stored last in the user file are loaded. <b>SAVE:</b> The user file settings which have been changed are saved. <b>INITIAL:</b> The user file settings are restored to the factory settings. <ul style="list-style-type: none"> <li>When the LOAD or INITIAL operation has been performed, set the POWER switch on the camera recorder to OFF and then to ON again in order to enable the settings.</li> </ul>
<b>HOUR METER</b> (Camera) (VCR)	For indicating the total rotational time of the cylinder head (5-digit display in 1-hour increments).

The underlining indicates the factory setting.

# Screen displays

## Camera mode and VCR mode

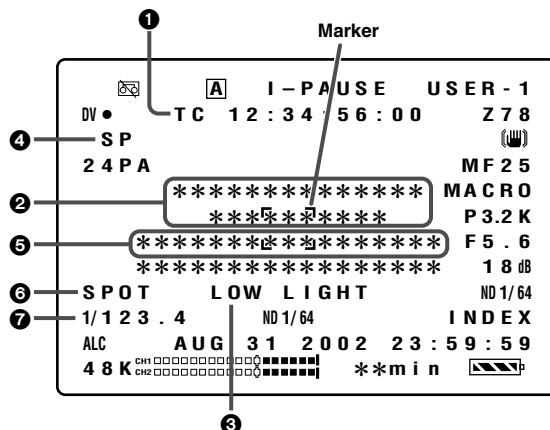

### 1 Counter display

Each time the COUNTER button is pressed, the data is selected in the sequence given below.

#### COUNTER:

Counter value

#### M COUNTER:

Counter value in the memory stop mode

#### TC:

Time code value

“TC\*” is displayed when the time code value could not be read out properly from the tape.

During operation in the drop frame mode, a colon (:) appears between the seconds and frames.

#### UB:

User's bit value

“UB\*” is displayed when the user's bit value could not be read out properly from the tape.

#### FR:

Information on the frame rate used when shooting

FR 60I : Standard (60i interlace) mode  
(60 fields per sec.)

FR 30P : 30P progressive mode  
(30 frames per sec.)

FR 24P : 24P progressive mode  
(24 frames per sec.)

FR 24PA: 24P advance mode  
(24 frames per sec.)

In the FR 24P and FR 24PA modes, the sequence information used for frame conversion is displayed at the last digits.

### 2 AWB/ABB operation status display

The operation statuses of the auto white balance and auto black balance are displayed here.

### 3 AWB error display

#### LOW LIGHT:

This appears when the luminance is too low during the auto white balance adjustment.

### 4 Recording time mode display (SP or LP)

### 5 Setting selection display

The selected setting appears here when a switch has been selected or a button has been pressed to select a setting.

### 6 Auto iris control status display

**STD** : Standard auto iris control

**SPOT** : Auto iris control for spotlight

**BACK** : Auto iris control for backlight compensation

### 7 Shutter speed display

The shutter speed is normally displayed here. When the ZEBRA button is pressed and the marker is displayed (see page 17), the video level of the image near the center of the screen is displayed as a value from 0% to 90%.

When the level exceeds 90%, “90%↑” is displayed.

# Screen displays

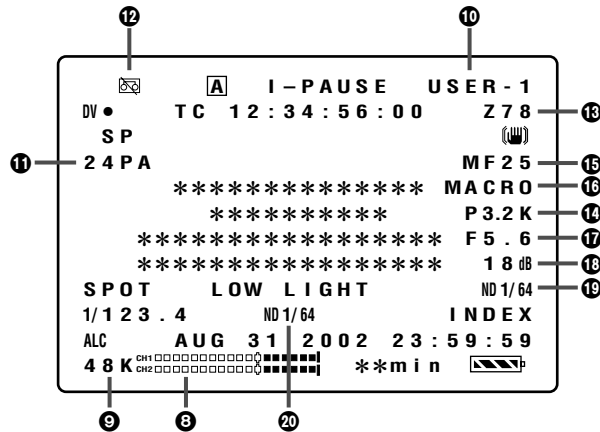

## 8 Audio level meter display



## 9 Audio sampling frequency display

## 10 Scene filename display

## 11 Progressive display

The information on the frame rate when shooting in the progressive mode is displayed here.

## 12 Warning information displays

### REMOTE:

This flashes when the component for which the wireless remote control unit is set is the wrong one.



This lights when condensation has formed inside the camera recorder.



This flashes when the cylinder head is dirty.



This flashes when the cassette tape has not been inserted or when it has been set to the recording inhibit mode.



This lights if a problem occurs in the camera recorder when face-to-face shooting is performed in the mirror mode.



This lights when the internal battery used for the calendar has run down.

## 13 Zoom position display

The zoom position from Z00 (max. wide angle) to Z99 (max. telephoto) appears here.

## 14 AWB information display

The white balance information appears here.

## 15 Focus control information display

The focus control information from 99 to 00 appears here.

95 (focal length: infinity)

:

50 (focal length: approx. 1 meter)

Under 49 (macro range)

:

00 (focal length: approx. 2 cm)

- Depending on the zoom position, the focus may not be within the macro range.

Similarly, depending on the zoom position, the lower limit of the macro range may differ.

## 16 Macro control display

## 17 Iris display

The F-number appears here.

## 18 Gain display

The gain value setting of the video amplifier appears here.

## 19 ND filter display

The selected ND filter appears here.

“ND –” appears on the display when the ND FILTER switch has shifted out of position (to a position other than OFF, 1/8 or 1/64). Check the ND FILTER switch position.

## 20 Recommended ND filter display

Displayed here is the ND filter which is recommended under the current shooting conditions.



# Screen displays

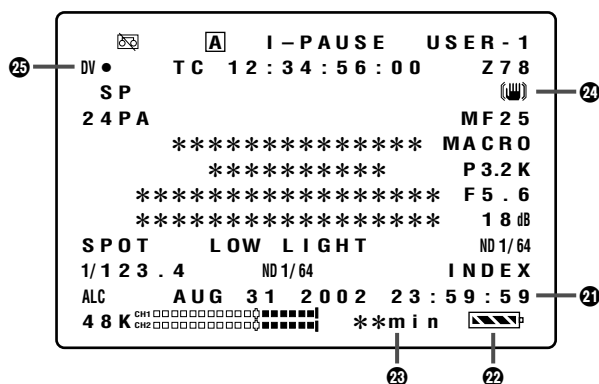

## 21 Date and time display

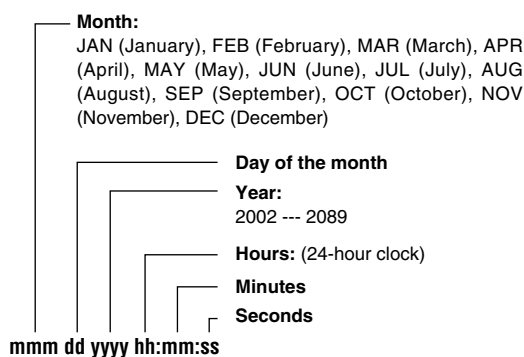

## 22 Remaining battery charge display

As the remaining battery charge diminishes, the display changes in the following sequence: → → → → .

When the battery has run down completely, (and then ) flashes.

(When the AC adapter is used, a display other than may appear: this is normal and not indicative of malfunctioning.)

## 23 Remaining tape display

Nothing appears here while the remaining tape is being calculated.

The remaining tape amount is not displayed when intermittent recording or slow-motion playback has been performed.

## 24 Camera shake compensation display

This appears when ON has been selected as the camera shake compensation function setting.

## 25 Backup component status displays

The status of the backup component connected to the DV connector appears here. It does not appear when OFF has been selected as the setting for the DV CONTROL item on the setting menu OTHER FUNCTIONS screen.

- DV ●** : Recording
- DV II** : Recording standby
- : Status in which the backup component cannot be controlled
- DV** : Backup component not connected
- DV --** : The backup component is connected, but the recording or recording standby mode has not been established.

# Screen displays

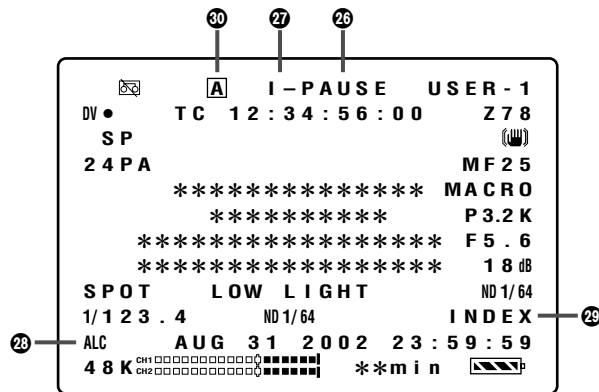

## 26 Operation mode displays

- REC** : Recording
- : Recording (during face-to-face shooting)
- PAUSE** : Recording standby
- || : Recording standby (during face-to-face shooting)
- : Playback pause
- STNDBY** : Standby (cylinder head rotation stopped)
- A. DUB** □□ : Audio dubbing recording standby
- A. DUB** ▷ : Audio dubbing
- ▷ : Playback
- ▷▷ (<<) : Fast forward/cue (rewind/review)
- ▷▷ (<□) : Slow playback (reverse slow playback)
- CHK** : Rec check
- ▷▷ (K<) : Search (reverse search)
- ▷ (<□□) : Frame advance playback (reverse frame advance playback)
- BLANK** : Blank search
- REC END** : Rec end search
- x▷/x▷▷ (x</x<<):  
Variable speed search (reverse variable speed search)

## 27 Intermittent recording display

This appears when ON or ONE-SHOT has been selected as the setting for the INTERVAL REC item on the setting menu RECORDING SETUP screen.

## 28 Mic level automatic control display

This appears when ON has been selected as the setting for the MIC ALC item on the setting menu RECORDING SETUP screen.

## 29 Index recording display

This lights when the INDEX button is pressed during recording and the index signal is recorded.  
It flashes when the INDEX button is pressed before recording (index signal recording standby status).

## 30 AUTO button operation display

“A” appears when the AUTO button has been pressed and the function which was set on the setting menu AUTO SW screen has been activated.

# Screen displays

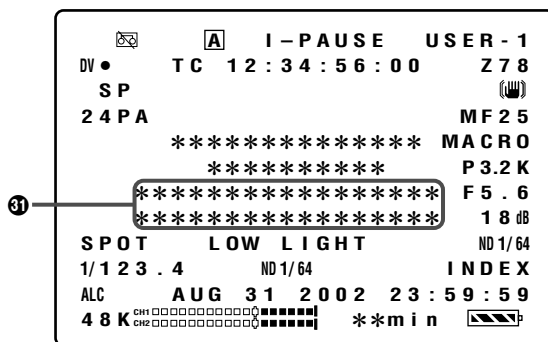

## 31 Warning displays

### UNPLAYABLE TAPE (OTHER FORMAT)

The tape cannot be played back since it has the wrong format.

### COPY INHIBITED

Since the input signals are copy-guarded, they cannot be recorded properly.

### UNABLE TO A. DUB (LP RECORDED)

Since the tape was recorded in the LP mode, audio dubbing cannot be performed.

### INCOMPATIBLE TAPE

Since the tape has different specifications (it may be a data storage tape, for instance), it cannot be used.

### EXTERNAL

#### DV DISCONNECT

This appears when EXT has been selected as the setting for the DV CONTROL item on the setting menu OTHER FUNCTIONS screen, and shooting has been performed without an external component connected to the DV connector.

### AUTO OFF

This appears when a problem has occurred in the tape transport system.

When this display appears, the camera recorder's power is automatically turned off.

#### CYLINDER LOCK

#### LOADING LOCK

#### UNLOADING LOCK

#### T REEL LOCK (take-up reel lock)

#### S REEL LOCK (supply reel lock)

### WARNING

This appears when a problem has occurred in the camera system.

#### FOCUS LOCK

(problem with focus operation)

#### PSD NG

(problem with camera shake detection)

#### GYRO NG

(problem with camera shake compensation control)

# Screen displays

## VCR mode

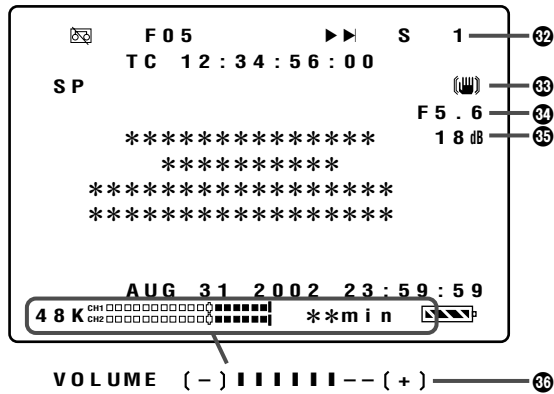

- 32 Search number display**  
 The index number used to perform the index search appears here. (S1 to S9)
- 33 Camera shake compensation (👋) display**  
 When ON has been selected as the setting for the CAMERA DATA item on the setting menu DISPLAY SETUP screen, (👋) is displayed also during tape playback for the camera data when images were shot in the camera shake compensation mode.
- 34 Iris display**  
 When ON has been selected as the setting for the CAMERA DATA item on the setting menu DISPLAY SETUP screen, the F-number during shooting is displayed also during tape playback as the camera data.
- 35 Gain display**  
 When ON has been selected as the setting for the CAMERA DATA item on the setting menu DISPLAY SETUP screen, the gain value during shooting is displayed also during tape playback as the camera data.
- 36 Playback volume level meter display**  
 When one of the AUDIO MON/VAR (+/-) buttons is pressed, the playback volume level meter is displayed.

# Screen displays

## Selecting the display

The items listed below which appear in the viewfinder and on the LCD monitor are displayed by the setting selected for the OTHER DISPLAY item (see page 45) of the setting menu DISPLAY SETUP screen.

Display item	MODE CHK button	OTHER DISPLAY item setting		
		ALL	PARTIAL	OFF
1 Counter display	○	—	—	—
4 Recording time mode display (SP or LP)	○	○	× (Camera) ○ (VCR)	×
6 Auto iris control status display	○	○	○	×
7 Shutter speed display	○	○	○	×
8 Audio level meter display	○	—	—	—
9 Audio sampling frequency display	○	○	× (Camera) ○ (VCR)	×
10 Scene filename display	○	○	×	×
11 Progressive display	○	○	×	×
13 Zoom position display	○	—	—	—
14 AWB information display	○	○	○	×
15 Focus control information display	○	—	—	—
17 Iris display	○	○	○	×
18 Gain display	○	○	×	×
19 ND filter display	○	○	×	×
20 Recommended ND filter display	○	○	○	×
21 Date and time display	○	—	—	—
22 Remaining battery charge display	○	—	—	—
23 Remaining tape display	○	—	—	—
24 Camera shake compensation display	○	○	○	×
28 Mic level automatic control display	○	○	×	×
30 AUTO button operation display	○	○	○	×

○ : Displayed  
 × : Not displayed  
 — : Displayed by another setting

# Connecting external components

- When an external component is to be connected and its video and audio signals are to be input to the camera recorder, connect the camera recorder to the output connectors on the external component.
  - Conversely, when an external component is to be connected and the video and audio signals of the camera recorder are to be input to the component, connect the camera recorder to the input connectors on the external component.
- If video signals have been input to both the S-VIDEO IN/OUT connector and VIDEO IN/OUT connector, the signals of the S-VIDEO IN/OUT connector take precedence.
  - It is not possible to record the audio signals if video signals are not input to the S-VIDEO IN/OUT connector or VIDEO IN/OUT connector except when performing audio dubbing.

- Before recording signals from an external component, check that the video signals are input.
- When signals from an external component are being recorded, do not stop the signal output at the external component side or disconnect any of the cables. It may not be possible for the component to be recognized when recording is resumed.

- A digital video component equipped with a DV connector can be connected, and its video signals, audio signals and time code, etc. can be transmitted digitally.
- When an IEEE 1394 cable has been connected to the DV connector, do not apply a strong load from outside. Doing so may damage the connector.

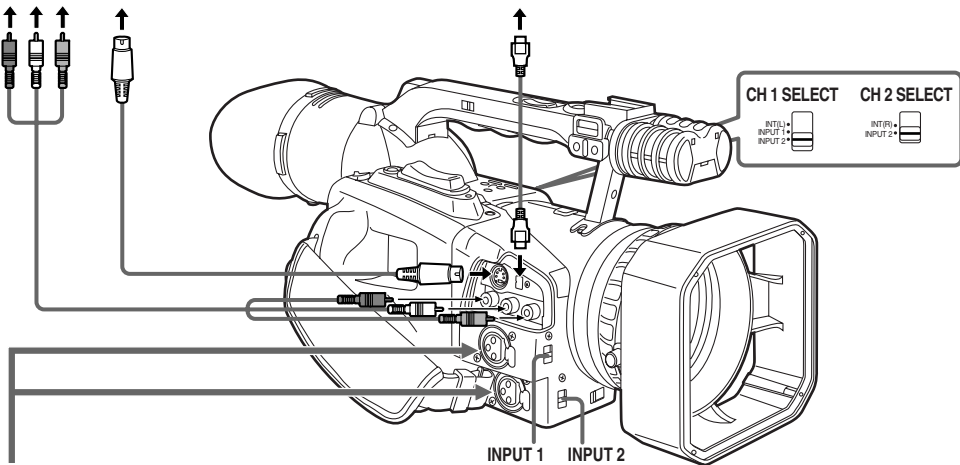

- When connecting an audio component, set the INPUT1 switch or INPUT2 switch to the LINE position.  
The input level is 0 dBu; the recording level is adjusted using the AUDIO controls.
- When connecting an external microphone, set the INPUT1 switch or INPUT2 switch to the MIC position.
  - Set the input level (-50 dBu and -60 dBu) using the MIC GAIN 1 and MIC GAIN 2 items on the setting menu RECORDING SETUP screen.
  - When mounting an external microphone on the microphone shoe of the camera recorder, use the accessory microphone holder and microphone holder adapter.

- To supply the signals from an external microphone to CH1 and CH2, connect the external microphone to the INPUT2 jack, and set both the CH1 SELECT and CH2 SELECT switches to the INPUT2 position. (See page 16)

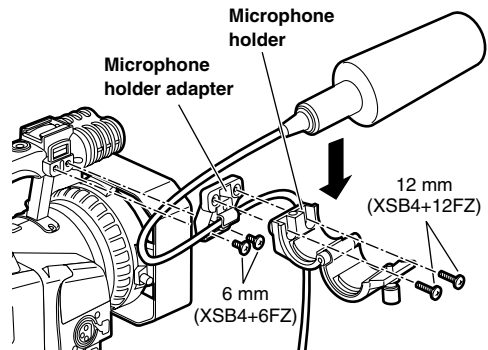

# Shooting

## Preparation and inspections

Before shooting, check that the camera recorder is operating properly. Also check that the equipment is set up in a way that is suited to the shooting conditions.

### ■ Batteries

Have a fully charged battery ready. It is also recommended that a spare battery be kept on hand as well.

### ■ Cassette tapes

Check that the cassette tapes available can be recorded on.

- Check that they have not been set to the accidental erasure prevention status.
- Check that they do not contain valuable video recordings.
- Check that the cassette holder is closed properly.

### ■ Viewfinder

Check that the diopter adjustment has been performed for the viewfinder.

### ■ Zoom, focus and iris

- Check whether the motor-driven zoom operations and manual zoom operations can be performed.
- Check whether the auto focus and manual focus operations can be performed.
- Check whether the auto iris and manual iris operations can be performed.

### ■ Time data

- Check whether the calendar and time are correct.
- Check whether the time code and user's bit have been set correctly.

### ■ External components

- Check whether the external components connected are operating properly.
- Check whether the external components have been connected properly.

## Regular shooting

Set the camera recorder's POWER switch to ON, and switch between shooting and shooting pause using the START/STOP button.

When shooting from a low angle, the START/STOP button on the handle can be used to initiate shooting.

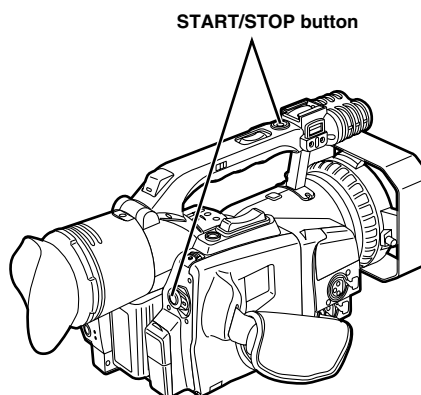

## REC check

When the REC CHECK button is pressed in the shooting pause mode, the picture and sound 2 seconds before the shooting was suspended are played back, and the shooting pause mode is then established again at the original position on the tape.

- If recording has not been performed for 1 or more seconds, the rec check function cannot be used.
- Bear in mind that when a backup component has been connected and used to record backup images, the rec check images will be recorded.

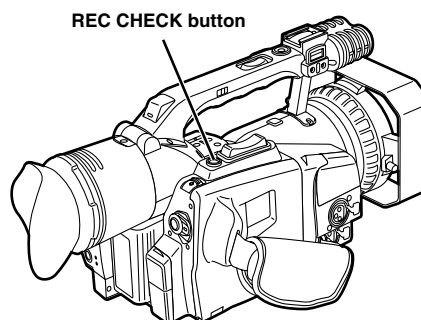

# Shooting



## Face-to-face shooting

When the LCD monitor is opened and rotated 180 degrees toward the lens, and the person operating the camera recorder records images of himself or herself, the impression of the shot images may appear to be different from usual.

If MIRROR is selected as the setting for the SELFSHOOT item on the setting menu DISPLAY SETUP screen, a left-right reversed image appears on the LCD monitor, and the person operating the camera recorder can shoot images of himself or herself that appear as if he or she is looking at himself or herself in the mirror.

However, even when shooting images in the mirror mode, the recorded images will be the same as ones which have been shot regularly as the images are not recorded as a mirror reflection.

When shooting in the mirror mode, the information which appears in the viewfinder and on the LCD monitor is limited to the following items:

- : Shooting
- || : Shooting pause
- ▣  : Remaining battery charge display
-  : Warning display

When  appears, return the LCD monitor to its original position, and check the message of the warning display.

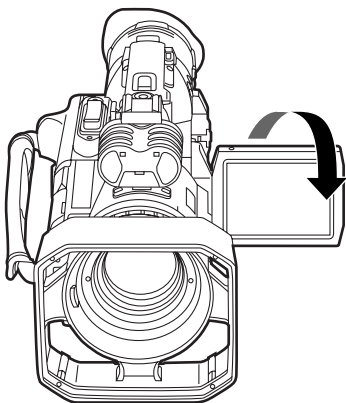

## Index recording

When the INDEX button is pressed during shooting or recording, the index signal is recorded on the tape.

When it is pressed while shooting or recording is temporarily stopped, the index signal is set to the recording standby status. When the shooting or recording is then resumed, the index signal is recorded on the tape at that time.

Searches (index searches) can be performed during playback once the index signals have been recorded.

## Using the USER buttons

One of nine functions can be allocated to the USER1 button and one can be allocated to the USER2 button.

In accordance with the subject concerned, the shooting conditions can be instantly selected or fade effects can be added to the images.

For details, refer to the USER1 and USER2 items (page 41) on the setting menu SW MODE screen.

## Intermittent recording

There are two intermittent recording modes: the mode in which images are shot at fixed intervals, and the frame-by-frame shooting mode.

- ① Set the shooting mode for intermittent recording using the INTERVAL REC item on the setting menu RECORDING SETUP screen. (See page 44)
  - If the progressive 24P mode or 24P (ADV) mode has been established, the INTERVAL REC item cannot be set.
- ② Set the recording time using the REC TIME item.
- ③ Set the standby time using the INTERVAL TIME item.
- ④ When the START/STOP button is pressed, recording starts in the shooting mode for intermittent recording.
- ⑤ When the OPERATION lever is tilted in the “■” direction, “I –” blinks, and intermittent recording is set to the temporary stop status.
  - While intermittent recording is in progress, no other operations are accepted.
  - While intermittent recording is in progress, the remaining tape amount is not displayed.

Even when the intermittent recording mode has been set, it will be returned to OFF when the power is turned off.



# Shooting

## Backup recording

The camera images of the camera recorder can be recorded and their recording can be backed up automatically on the external component connected to the DV connector.

- Set the external component control method using the DV CONTROL item and DV CMD SEL item on the setting menu OTHER FUNCTIONS screen. (See page 46)

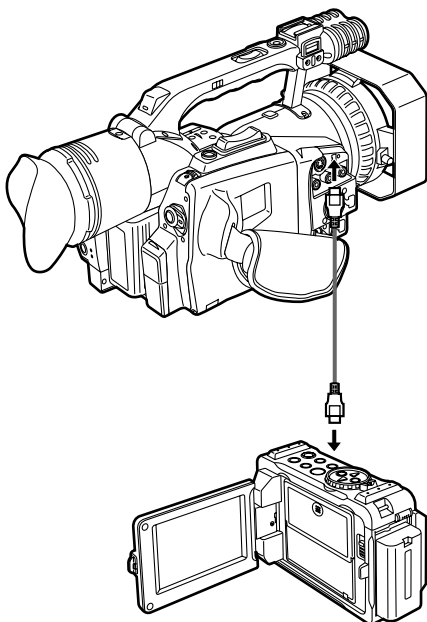

### **Bear in mind the following points when performing backup recording.**

- The menu item settings remain stored in the memory even after the power has been turned off. Therefore, if the camera recorder is used while the settings for backup recording are still in place, the images may be overwritten on the tape in the connected component.  
Upon completion of the backup recording, check the menu item settings before operating the camera recorder.
- If another model AG-DVX100 is to be used as the external component which will perform the backup recording, select OFF as the setting for the DV CONTROL item of the external component, and set the camera recorder to the VCR mode for use.
- When backup recording is to be performed, operation may not proceed properly if two or more external components are connected.
- Ensure that the IEEE 1394 cable used for the connection is not more than 4.5 meters long.
- Before proceeding with backup recording, establish the status in which the DV signals can be recorded by the external component.
- When the tape in the camera recorder is approaching the end during shooting while backup recording is being performed with "CHAIN" selected as the setting for the DV CONTROL item (page 46), recording is automatically started by the back-up component which has been set to the recording standby mode.

# Shooting

## Progressive shooting

The progressive mode can be selected using the PROGRESSIVE item (see page 39) of the setting menu SCENE FILE screen.

### 30P mode:

Images are shot in the progressive mode at 30 frames per second.

The 30 frames per second images are converted into 60-field interlace signals, and the resulting video signals are output or recorded.

Shift-free, high-quality still pictures can be obtained in this mode.

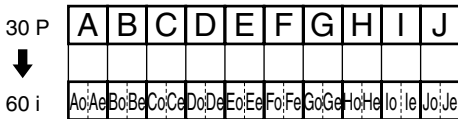

### 24P mode:

Images are shot in the progressive mode at 24 frames per second.

The 24 frames per second images are converted into 60-field interlace signals using the regular [2:3] conversion system, and the resulting video signals are output or recorded. Cinema-like images can be obtained in this mode.

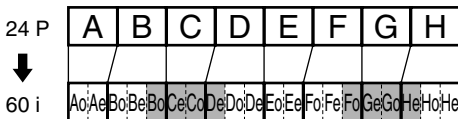

### 24P advance mode:

Images are shot in the progressive mode at 24 frames per second.

The 24 frames per second images are converted into 60-field interlace signals by the advanced conversion system, and the resulting video signals are output or recorded.



When editing images using the conventional 24P [2:3] conversion system, the images of different frames are expanded for the [BoCe] [CoDe] [FoGe] [GoHe] frames in the figure, causing the picture quality to further deteriorate. Under the 24P advanced conversion system, images with minimal picture quality deterioration in the 24P mode can be obtained by weeding out the [BoCe] [FoGe] frames in the figure. Furthermore, when an editing system that supports the advanced conversion system is used, editing can be performed with minimal picture quality deterioration compared with the 24P mode.

- When an editing system that supports the advanced conversion system is not going to be used, shoot in the regular 24P mode.

### Bear in mind the following points when shooting in any of the progressive modes.

- The color bars cannot be displayed.
- The gain cannot be controlled. The gain value is controlled using a fixed value.
- The auto focus cannot be controlled.
- When the progressive mode has been selected, the sync signals of the images are temporarily disturbed. Furthermore, no images are output for approximately 3 seconds.
- A shutter speed setting of 1/50 (OFF) or 1/60 is recommended.
- Since the images are recorded in 5-frame increments when shooting in the 24P mode or 24P advance mode, the timing at which recording starts may be delayed slightly.
- When shooting in the progressive mode using the ATW (Auto Tracking White) function, it will not be possible to adjust the black balance even by pressing the AWB button.

# Playback

## Normal playback

Set the POWER switch to ON, and press the CAMERA/VCR button to switch to the VCR mode.

Normal playback operations can be performed using the OPERATION lever or accessory wireless remote control unit.

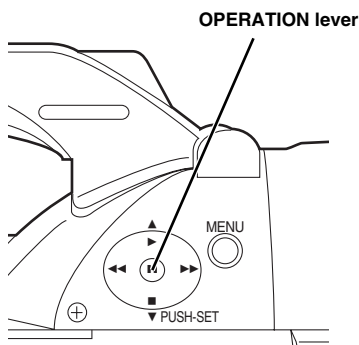

### Tape protection mode

When the camera recorder remains in the playback pause or recording pause mode for more than 5 minutes, it is automatically set to the stop mode in order to protect the tape. However, if it remains in the playback pause mode when the temperature is low, the stop mode may be established sooner.

## Tape blank search

By pressing the END SEARCH button in the VCR mode, it is possible to search for unrecorded parts on the tape or the part which was shot last. For details, refer to the section on the END SEARCH button (page 11).

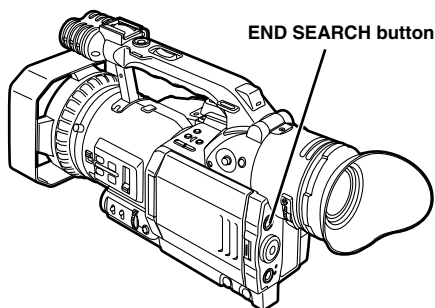

## Variable speed search

This function changes the playback speed to locate scenes.

- When the OPERATION lever is tilted in the ► direction during tape playback, the variable search mode is established, "1×" appears in the viewfinder and on the LCD monitor, and the tape is played back at the 1× speed. No sound is played back at this time.
- The playback speed changes when the AUDIO MON/VAR button is pressed. Each time the button is pressed, the playback speed changes by one setting in the following sequence: 1/5× (or 1/3× in the LP mode), 1×, 2×, 5×, 10× and 20×.
- The speed is varied in the forward direction using the "+" button; conversely it is varied in the reverse direction using the "-" button.
- When the remote control is used, pressing the VAR.SEARCH button establishes the variable speed search mode, and the playback direction and playback speed are changed using the "▲" and "▼" buttons among the SET buttons.
- To return to normal playback, tilt the OPERATION lever in the ► direction.

## Index search

This function is used to search the index signals recorded on the tape. An index search can be performed using the accessory wireless remote control unit.

- During tape playback, press the INDEX button (▶▶| or |◀◀) on the wireless remote control unit. "S1" appears in the viewfinder and on the LCD monitor, and the search for the next scene is started.
- To stop the search at any time, press the STOP (■) button.
- Each time the INDEX button is pressed after the search operation has commenced, "S2" "S3" are displayed, and the second or any subsequent scene can be searched. When a scene is located, playback commences from that part of the tape. (Any scene up to the ninth in the reverse or forward direction from the present position of the tape can be specified.)  
The index search function may not operate smoothly if any of the intervals between one index and the next are less than one minute.

# Condensation

---

## How to tell when condensation has formed inside and what to do about it

If, after the camera recorder's power has been turned on, the  condensation display symbol flashes, it means that condensation has formed inside the camera recorder. If this happens, the power will be automatically turned off after several seconds.

Take the following action.

### ① Remove the cassette.

No other functions will work. Depending on the degree of condensation, it may not be possible to eject the cassette, either. In this case, wait two or three hours, and then try ejecting the cassette.

### ② Wait two or three hours with the cassette holder open.

The wait time differs depending on the degree of condensation and the ambient temperature.

### ③ After two or three hours have elapsed, turn on the power, and check whether the condensation display has gone off.

Even if the condensation display has gone off, wait another hour to be on the safe side before attempting to operate the camera recorder.

## Bear in mind that condensation may be forming before the condensation display comes on.

- Condensation forms gradually so that the condensation display may not appear for the first 10 to 15 minutes after it has started to form inside.
- In very cold climates, condensation may freeze and turn into frost. In this case, it will take two or three hours for the frost to melt and become condensation again.

# Video heads

---

If the video heads are dirty, mosaic-type noise may occur in some areas or the whole image may turn blue when playing back a tape.

If the dirt accumulates, the recording capability will deteriorate, and in the end it will not be possible to record.

## Causes of dirty heads

- High concentrations of dust in the atmosphere
- Environments which are very hot and very humid
- Tape damage
- Prolonged operation

## Using the cleaning cassette tape (accessory)

### ① Insert the cleaning tape in the camera recorder, and set the POWER switch to ON.

### ② Press the CAMERA/VCR button, and check that the VCR lamp has lighted.

### ③ Tilt the OPERATION lever in the ► direction, and allow 10 seconds to pass before tilting it in the ■ direction. (Do not rewind the tape at this point.)

### ④ Remove the cleaning tape, proceed with a test recording and playback using another tape, and check the images.

### ⑤ If the images are not clear, repeat steps ① to ④.

(Do not run the cleaning tape continuously more than 4 times.)

- Do not rewind the cleaning tape at any interim point. At the end of the tape, rewind it, and use it again from the start.
- If the heads are still dirty even after cleaning, it may mean that the tape itself has deteriorated so stop using it immediately.
- Overuse of the cleaning tape causes head wear. If the heads are worn, clear pictures will not be played back even immediately after the heads have been cleaned.
- If the cleanliness of the heads is not improved by the cleaning tape, the camera recorder must be cleaned and/or repaired by your local dealer. Consult with your dealer.

## Regular inspections

In order to view clean and clear images, it is recommended that the video heads and other worn parts be replaced after they have been used for about 1,000 hours (This period will vary significantly depending on the temperature, humidity, dust and other conditions in the operating environment.)

# Troubleshooting (Q&A)

---

## Power supply-related problems

### Q1: No power.

A1: Has the battery or AC adapter been connected correctly? Check the connections. (See page 22)

### Q2: The power goes off on its own.

A2: The power will automatically go off if shooting is temporarily stopped for more than 5 minutes in order to prevent the battery from running down and keep the tape from wearing.

Check the setting selected for the TAPE PROTECT item on the setting menu OTHER FUNCTIONS screen. (See page 46)

### Q3: The power is turned on but it goes off immediately.

A3-1: Has the battery run down?

If the remaining battery charge display flashes or the  display has appeared, it means that the battery has run down.

Recharge the battery or insert an adequately charged battery. (See page 21)

A3-2: Has condensation formed?

When the camera recorder has been carried into a warm room from a cold place, condensation may form inside. If this happens, the power is automatically turned off, and ejecting the cassette is the only operation which can be performed. Wait until the condensation has dried up. (See page 60)

## Battery-related problems

### Q1: The battery runs down quickly.

A1-1: Has the battery been adequately charged? Charge it until the CHARGE lamp of the AC adapter has gone off. (See page 21)

A1-2: Is the camera recorder being used in cold place?

The battery is easily affected by the ambient temperature. Its operating time is reduced in cold locations.

A1-3: Has the battery reached the end of its service life?

The service life of the battery differs depending on how it is used. If it works only for a short time even after it has adequately charged, it means that the battery has reached the end of its service life.

### Q2: The battery cannot be charged.

A2: Is the DC cable connected to the AC adapter? The battery cannot be charged if this cable is connected.

## Problems during normal video recording

### Q1: Recording is not possible even though the cassette tape has been inserted properly.

A1-1: Has the accidental erasure prevention knob on the cassette tape been set to "SAVE?" If it has, recording cannot be performed. (See page 23)

A1-2: Has the cassette tape reached the end? Replace it with a new one.

A1-3: Is the POWER switch at the ON position?

A1-4: Is the VCR lamp lighted?

Shooting is not possible in the VCR mode.

A1-5: Is the cassette holder open?

If the cassette holder is open, it is not possible to perform any VCR operations.

A1-6: Has condensation formed?

If condensation has formed, ejecting the cassette tape is the only operation which can be performed. Wait until the condensation dries up. (See page 60)

A1-7: If AUTO OFF/T REEL LOCK appears on the display, the tape may have snapped. Check the tape.

# Troubleshooting (Q&A)

---

## Problems during various kinds of video recording

### Q1: No automatic focusing

A1-1: Has the manual focus mode been set? The focus is adjusted automatically in the auto focus mode. (See page 12)

A1-2: Is a scene which is hard to bring into focus in the auto focus mode being shot? Some scenes are hard to bring into focus using auto focus. In cases like this, use the manual focus mode instead for focusing.

### Scenes hard to bring into focus

- Shooting both distant and close-up subjects
- Shooting subjects through dirty window panes
- Shooting subjects in dark locations
- Shooting while objects that glitter or dazzle are around the subject
- Shooting fast-moving subjects
- Shooting subjects with minimal contrast

## Editing-related problems

### Q1: No audio dubbing.

A1-1: Has the accidental erasure prevention knob on the cassette tape been set to "SAVE?" If it has, recording cannot be performed. (See page 23)

A1-2: Has an attempt been made to edit parts shot in the LP mode? Audio dubbing cannot be performed as the track width on the tape is narrower than the head width in the LP mode.

## Display-related problems

### Q1: Something is wrong with the time code display.

A1: When the reverse slow playback mode is set, the count shown on the time code display becomes inconsistent; however, this is normal and not indicative of malfunctioning.

### Q2: The remaining tape display does not match the actual amount of tape remaining.

A2-1: The remaining tape is not displayed accurately with continuous shooting sessions lasting less than 30 seconds.

A2-2: A display which is two to three minutes less than the actual tape remaining time sometimes appears.

## Playback-related problems (video)

### Q1: No playback, even when the play button is pressed.

A1: Has the CAMERA/VCR button been pressed and has the VCR lamp lighted? If the VCR lamp is not lighted, playback-related operations cannot be performed. (See page 11)

### Q2: Mosaic-type noise is generated during cue and review.

A2: This is a phenomenon inherent to digital video. It is not indicative of malfunctioning.

### Q3: No playback images are seen even though the camera recorder is connected with the TV set correctly.

A3: Is the TV set's input selector at "video input?" Read through the operating instructions of the TV set, and select the video input connector to which the camera recorder has been connected.

### Q4: The playback images are not displayed clearly.

A4: Are the camera recorder's heads dirty? If they are dirty, the playback images will not be displayed clearly.

# Troubleshooting (Q&A)

---

## Playback-related problems (audio)

**Q1: No playback sound is heard from the camera recorder's speaker.**

A1: Has the camera recorder's volume level been set too low?

In the VCR mode, press the AUDIO MON/VAR button "+" to increase the volume. (See page 15)

**Q2: More than one recorded stream of sound is heard.**

A2: Has MIX been selected as the setting for the 12-bit AUDIO item on the setting menu PLAYBACK FUNCTIONS screen? (See page 42)

If audio dubbing editing is performed on a tape recorded with 12-bit selected as the setting for the AUDIO REC item on the setting menu RECORDING SETUP screen, the sound heard during the recording and the sound recorded later will be heard together. It is also possible to listen to each stream of sound separately. (See page 43)

**Q3: When audio dubbing is performed, the original sound is erased.**

A3: When audio dubbing is performed for a part which was shot with 16-bit selected as the setting for the AUDIO REC item on the setting menu RECORDING SETUP screen, the original sound will be erased. Use the 12-bit setting during shooting. (See page 43)

## Other types of problems

**Q1: The cassette tape cannot be ejected.**

A1: Is power being supplied?

Has the AC adapter been plugged in or the battery inserted properly?

When the power is supplied, the cassette can be ejected without setting the POWER switch to ON.

**Q2: Ejecting the cassette tape is the only operation which can be performed.**

A2-1: Has any condensation formed?

If condensation forms, ejecting the cassette tape is the only operation which can be performed. Wait until the condensation dries up. (See page 60)

A2-2: When the cassette holder is closed immediately after opening (by sliding the EJECT switch), operations other than eject may not be possible.

If this does happen, slide the EJECT switch to open the cassette holder once again, then close the holder after ensuring that the cassette mechanism has completed the eject operation.

**Q3: The remote control unit does not work.**

A3-1: Has the battery in the remote control unit run down?

If the remote control unit fails to operate even when it is operated near the remote control sensor of the camera recorder, it means that the button battery has run down.

Replace it with a new one. (See page 20)

A3-2: Do the remote control settings match properly?

If the [REMOTE] settings of the remote control unit and camera recorder do not match, the remote control unit will not work even when it is operated. (See page 20)

**Q4: A rattling sound is heard when the camera recorder is tilted toward the front or back.**

A4: When the VCR mode is established or the power switch is at OFF, a rattling sound may be heard from the camera unit due to its structure. This is not indicative of malfunctioning.

# Maintenance

---

## Do not use benzine or paint thinners to clean the camera recorder.

- Use of benzine or paint thinners may cause the camera recorder body to become deformed or the surface coating to peel off.
- When cleaning or otherwise maintaining the camera recorder, either remove its battery or disconnect its AC cable from the power outlet.
- Use a soft, clean cloth to wipe the camera recorder. To remove stubborn stains, dilute some kitchen detergent, dip a cloth into the solution and use it to wipe off the dirt, and then remove any remaining moisture with a dry cloth.

## Viewfinder maintenance

When dust has collected inside the viewfinder, take off the eye cup holder, and remove the dust.

- The inside of the eye cup holder has a special coating: for this reason, it must not be wiped under any circumstances. When dust has collected, use an air blower or similar device to blow off the dust.
- Point the viewfinder slightly upward, then remove the eye cup holder by turning it counterclockwise.
- To attach the eye cup holder, turn it clockwise with the index mark on the eye cup holder face up.

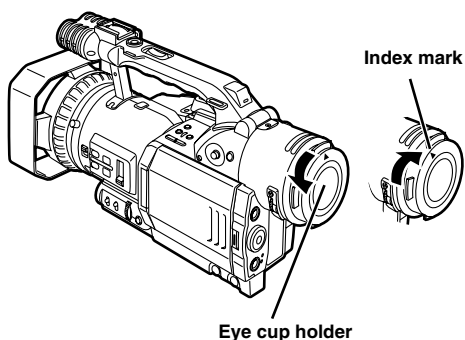



# Specifications

## [GENERAL]

**Supply voltage:** DC 7.2/7.9 V

**Power consumption:**

6.8 W (when viewfinder is used)

7.8 W (when LCD monitor is used)

9.2 W (max.)

 indicates safety information.

### Ambient operating temperature

32°F to +104°F (0°C to +40°C)

### Ambient operating humidity

10% to 85% (no condensation)

### Weight

3.652 lb (1.66 kg)

(excluding battery and accessories)

### Dimensions (W×H×D)

5 1/2×6 5/16×14 3/8 inches

(139×160×364 mm)

### Recording format

Digital video SD format

### Tape format

Mini DV

### Recorded video signals

525i (NTSC)

In the progressive mode, the signals are converted into the 525i system and recorded.

### Shooting mode

60i (525i)

Progressive mode (30P, 24P or 24P advance)

### Recorded audio signals

PCM digital recording

16 bits: 48 kHz/2 channels

12 bits: 32 kHz/4 channels

### Recording tracks

Digital video, audio signals:

helical track

Time code:

helical track (sub-code area)

### Tape speed

SP mode: 18.812 mm/sec.

LP mode: 12.555 mm/sec.

### Recording time (when AY-DVM60 is used)

SP mode: 60 minutes

LP mode: 90 minutes

### Tape used

6.35 mm wide metal tape

### FF/REW time

Approx. 85 sec. (when AY-DVM60 is used)

### Pick-up device

Interline transfer 1/3-inch CCD image sensor (×3)

### Number of pixels

Total number of pixels: 410,000,

Number of effective pixels: 380,000

(pixel offset system)

### Lens

Leica DICOMAR optical image stabilizer lens, motorized/manual mode switching, 10× zoom F1.6 (f = 4.5 to 45 mm)

(35 mm equivalent: 32.5 to 325 mm)

### Optical system

Prism system

### ND filters

1/8, 1/64

### Gain

0, +3, +6, +9, +12, +18 dB (60i mode only)

### Shutter speeds

Preset

60i mode:

1/60 (OFF), 1/100, 1/120, 1/250, 1/500,

1/1000, 1/2000 sec.

30P mode:

1/30, 1/50 (OFF), 1/60, 1/120, 1/250,

1/500, 1/1000 sec.

24P, 24P (ADV) mode:

1/24, 1/50 (OFF), 1/60, 1/120, 1/250,

1/500, 1/1000 sec.

Synchro scan

60i mode:

1/60.3 to 1/250.0 sec.

30P mode:

1/30.1 to 1/250.0 sec.

24P, 24P (ADV) mode:

1/24.1 to 1/250.0 sec.

### Minimum subject illuminance

3 lux (F1.6, 18 dB gain, 50 IRE video output)

### Lens hood

Large-sized lens hood with wide angle of view

### Filter diameter

72 mm

### LCD monitor

3.5-inch LCD color monitor, 200,000 pixels

### Viewfinder

0.44-inch LCD color viewfinder, 180,000 pixels

### Internal microphone

Stereo microphone

### Internal speaker

20 mm diameter

# Specifications

---

## [VIDEO]

### Sampling frequency

Y: 13.5 MHz, PB/PR: 3.375 MHz

### Quantizing

8 bits

### Video compression system

DCT + variable length code

### Error correction

Reed-Solomon product code

## [AUDIO]

### Sampling frequency

48 kHz/32 kHz

### Quantizing

16 bits/12 bits

### Frequency response

20 Hz to 20 kHz

### Wow & flutter

Below measurable limits

## [CONNECTORS]

### VIDEO IN/OUT (input/output automatically switched)

Pin jack, analog composite input/output, 1.0 V [p-p], 75  $\Omega$

### S-VIDEO IN/OUT (input/output automatically switched)

S-connector, Y/C separate signal input/output, Y: 1.0 V [p-p], C: 0.286 V [p-p], 75  $\Omega$

### AUDIO IN/OUT (input/output automatically switched)

Pin jacks  $\times 2$  (CH1, CH2)  
Input: 316 mV, high impedance  
Output: 316 mV, 600  $\Omega$

### DV

4-pin, digital input/output, IEEE 1394 standard complied with

### INPUT 1, INPUT 2

XLR (3 pins)  $\times 2$  (CH1, CH2)  
LINE/MIC switching, high impedance  
LINE: 0 dBu  
MIC : -50 dBu/-60 dBu (menu selection)

### DC INPUT

7.9 V

### PHONES

Stereo (3.5 mm diameter), 77 mV, 32  $\Omega$

### CAM REMOTE

Mini jack (2.5 mm diameter)

## [AC ADAPTER]

### Power Source:

110/120/220/240 V AC, 50/60 Hz

### Power Consumption:

18 W

 indicates safety information.

### Weight

0.35 lb (0.16 kg)

### Dimensions (W $\times$ H $\times$ D)

2  $\frac{13}{16}$   $\times$  1  $\frac{13}{16}$   $\times$  4  $\frac{5}{8}$  inches  
(70  $\times$  44.5  $\times$  116 mm)

## [OPTIONAL ACCESSORIES]

### Wide conversion lens

AG-LW7208G

### 16:9 conversion lens

AG-LA7200G

### XLR microphone

AG-MC100G

### Hard carrying case

AG-HT100G

### Soft carrying case

AG-SC100G

### Battery

CGR-D08 (800 mAh)

CGR-D16 (1600 mAh: product equivalent to battery supplied)

CGP-D28 (2800 mAh)

### AC adapter kit

AG-B15 (product equivalent to AC cable, DC cable and AC adapter supplied)

### Cleaning tape

AY-DVMCL

Weight and dimensions shown are approximate. Specifications are subject to change without notice.



---

# Panasonic

**PANASONIC BROADCAST & TELEVISION SYSTEMS COMPANY**  
UNIT COMPANY OF MATSUSHITA ELECTRIC CORPORATION OF AMERICA

**Executive Office:**

One Panasonic Way 4E-7, Secaucus, NJ 07094 (201) 348-7000

**EASTERN ZONE:**

One Panasonic Way 4E-7, Secaucus, NJ 07094 (201) 348-7621

**Southeast Region:**

1225 Northbrook Parkway, Ste 1-160, Suwanee, GA 30024 (770) 338-6835

**Central Region:**

1707 N Randall Road E1-C-1, Elgin, IL 60123 (847) 468-5200

**WESTERN ZONE:**

3330 Cahuenga Blvd W., Los Angeles, CA 90068 (323) 436-3500

**Government Marketing Department:**

52 West Gude Drive, Rockville, MD 20850 (301) 738-3840

**Broadcast PARTS INFORMATION & ORDERING:**

9:00 a.m. – 5:00 p.m. (EST) (800) 334-4881/24 Hr. Fax (800) 334-4880

Emergency after hour parts orders (800) 334-4881

**TECHNICAL SUPPORT:**

Emergency 24 Hour Service (800) 222-0741

**Panasonic Canada Inc.**

5770 Ambler Drive, Mississauga, Ontario L4W 2T3 (905) 624-5010

**Panasonic de Mexico S.A. de C.V.**

Av angel Urraza Num. 1209 Col. de Valle 03100 Mexico, D.F. (52) 1 951 2127

**Panasonic Sales Company**

**Division of Matsushita Electric of Puerto Rico Inc.**

San Gabriel Industrial Park, 65th Infantry Ave., Km. 9.5, Carolina, Puerto Rico 00630 (787) 750-4300