

OLYMPUS®

Digital Camera Instructions

D-300L
D-200L

- Before using your camera, read this manual carefully to ensure correct use.
- We recommend that you take test shots to get accustomed to your camera before taking important photographs.

▶ Preparations

▶ Taking pictures

▶ Displaying pictures on the LCD monitor

▶ Transferring images to a personal computer

▶ Others

Serial number

Digital camera	
CD-ROM	

**CAUTION**RISK OF ELECTRIC SHOCK
DO NOT OPEN

CAUTION: TO REDUCE THE RISK OF ELECTRIC SHOCK, DO NOT REMOVE COVER (OR BACK) NO USER-SERVICEABLE PARTS INSIDE REFER SERVICING TO QUALIFIED SERVICE PERSONNEL

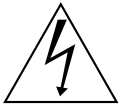

The lightning flash with arrowhead symbol, within an equilateral triangle, is intended to alert the user to the presence of uninsulated "dangerous voltage" within the product's enclosure that may be of sufficient magnitude to constitute a risk of electric shock to persons.



The exclamation point within an equilateral triangle is intended to alert the user to the presence of important operating and maintenance (servicing) instructions in the literature accompanying the product.

WARNING:

TO REDUCE THE RISK OF FIRE OR SHOCK HAZARD, DO NOT EXPOSE THIS EQUIPMENT TO RAIN OR MOISTURE.

IMPORTANT SAFETY INSTRUCTIONS

1. **Read Instructions** — All the safety and operating instructions should be read before the product is operated.
2. **Retain Instructions** — The safety and operating instructions should be retained for future reference.
3. **Heed Warnings** — All warnings on the product and in the operating instructions should be adhered to.
4. **Follow Instructions** — All operating and use instructions should be followed.
5. **Cleaning** — Unplug this product from the wall outlet before cleaning. Do not use liquid cleaners or aerosol cleaners. Use a damp cloth for cleaning.

***Exception:** A product that is meant for uninterrupted service and that for some specific reason, such as the possibility of the loss of an authorization code for a CATV converter, is not intended to be unplugged by the user for cleaning or any other purpose, may exclude the reference to unplugging the product in the cleaning description otherwise required in this section.*

-
6. **Attachments** — Do not use attachments not recommended by the product manufacturer as they may cause hazards.
 7. **Water and Moisture** — Do not use this product near water — for example, near a bath tub, wash bowl, kitchen sink, or laundry tub; in a wet basement; or near a swimming pool; and the like.
 8. **Accessories** — Do not place this product on an unstable stand, tripod, bracket, table, or cart. The product may fall, causing serious injury to a child or adult, and serious damage to the product. Use only with a tripod, stand, bracket. Any mounting of the product should follow the manufacturer's instructions, and should use a mounting accessory recommended by the manufacturer.
 9. A product and cart combination should be moved with care. Quick stops, excessive force, and uneven surfaces may cause the product and cart combination to overturn.

PORTABLE CART WARNING
(Symbol provided by RETAC)



10. **Ventilation** — Slots and openings in the cabinet are provided for ventilation and to ensure reliable operation of the product and to protect from overheating, and these openings must not be blocked or covered. The openings should never be blocked by placing the product on a bed, sofa, rug, or other similar surface. This product should not be placed in a built-in installation such as a bookcase or rack unless proper ventilation is provided or the manufacturer's instructions have been adhered to.
11. **Power Sources** — This product should be operated only from the type of power source indicated on the label. If you are not sure of the type of power supply to your home, consult your product dealer or local power company. For products intended to operate from battery power, or other sources, refer to the operating instructions.
12. **Grounding or Polarization** — This product may be equipped with a polarized alternating-current line plug (a plug having one blade wider than the other). This plug will fit into the power outlet only one way. This is a safety feature. If you are unable to insert the plug fully into the outlet, try reversing the plug. If the plug should still fail to fit, contact your electrician to replace your obsolete outlet. Do not defeat the safety purpose of the polarized plug.

Alternate Warnings — This product is equipped with a three-wire grounding-type plug, a plug having a third (grounding) pin. This plug will only fit into a grounding-type power outlet. This is a safety feature. If you are unable to insert the plug into the outlet, contact your electrician to replace your obsolete outlet. Do not defeat the safety purpose of the grounding-type plug.

13. Power-Cord Protection — Power-supply cords should be routed so that they are not likely to be walked on or pinched by items placed upon or against them, paying particular attention to cords at plugs, convenience receptacles, and the point where they exit from the product.

14. Protective Attachment Plug — The product is equipped with an attachment plug having overload protection. This is a safety feature. See Instruction Manual for replacement or resetting of protective device. If replacement of the plug is required, be sure the service technician has used a replacement plug specified by the manufacturer that has the same overload protection as the original plug.

EXAMPLE OF ANTENNA GROUNDING AS PER NATIONAL ELECTRICAL CODE, ANSI/NFPA 70

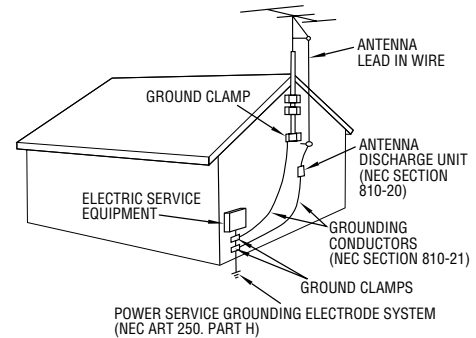

NEC – NATIONAL ELECTRICAL CODE

-
- 15. Outdoor Antenna Grounding** — If an outside antenna or cable system is connected to the product, be sure the antenna or cable system is grounded so as to provide some protection against voltage surges and built-up static charges. Article 810 of the National Electrical Code, ANSI/NFPA 70, provides information with regard to proper grounding of the mast and supporting structure, grounding of the lead-in wire to an antenna discharge unit, size of grounding conductors, location of antenna-discharge unit, connection to grounding electrodes, and requirements for the grounding electrode. See figure “Example of antenna grounding as per National Electrical Code, ANSI/NFPA 70”
- 16. Lightning** — For added protection for this product during a lightning storm, or when it is left unattended and unused for long periods of time, unplug it from the wall outlet and disconnect the antenna or cable system. This will prevent damage to the product due to lightning and power-line surges.

- 17. Power Lines** — An outside antenna system should not be located in the vicinity of overhead power lines or other electric light or power circuits, or where it can fall into such power lines or circuits. When installing an outside antenna system, extreme care should be taken to keep from touching such power lines or circuits as contact with them might be fatal.
- 18. Overloading** — Do not overload wall outlets, extension cords, or integral convenience receptacles as this can result in a risk of fire or electric shock.
- 19. Object and Liquid Entry** — Never push objects of any kind into this product through openings as they may touch dangerous voltage points or short-out parts that could result in a fire or electric shock. Never spill liquid of any kind on the product.
- 20. Servicing** — Do not attempt to service this product yourself as opening or removing covers may expose you to dangerous voltage or other hazards. Refer all servicing to qualified service personnel.

21. Damage Requiring Service — Unplug this product from the wall outlet and refer servicing to qualified service personnel under the following conditions:

- a) When the power-supply cord or plug is damaged.
- b) If liquid has been spilled, or objects have fallen into the product.
- c) If the product has been exposed to rain or water.
- d) If the product does not operate normally by following the operating instructions. Adjust only those controls that are covered by the operating instructions as an improper adjustment of other controls may result in damage and will often require extensive work by a qualified technician to restore the product to its normal operation.
- e) If the product has been dropped or damaged in any way.
- f) When the product exhibits a distinct change in performance — this indicates a need for service.

22. Replacement Parts — When replacement parts are required, be sure the service technician has used replacement parts specified by the manufacturer or have the same characteristics as the original part. Unauthorized substitutions may result in fire, electric shock, or other hazards.

23. Safety Check — Upon completion of any service or repairs to this product, ask the service technician to perform safety checks to determine that the product is in proper operating condition.

24. Heat — The product should be situated away from heat sources such as radiators, heat registers, stoves, or other products (including amplifiers) that produce heat.

Note to CATV system installer

This reminder is provided to call the CATV system installer's attention to Article 820-40 of the NEC that provides guidelines for proper grounding and, in particular, specifies that the cable ground shall be connected to the grounding system of the building, as close to the point of cable entry as practical.

Radio and Television Interference

- Change or modifications not expressly approved by the manufacturer may void the user's authority to operate this equipment.

This equipment has been tested and found to comply with the limits for Class B digital device, pursuant to Part 15 of the FCC Rules. These limits are designed to provide reasonable protection against harmful interference in a residential installation. This equipment generates, uses, and can radiate radio frequency energy and, if not installed and used in accordance with the instructions, may cause harmful

interference to radio communications. However, there is no guarantee that interference will not occur in particular installation. If this equipment does cause harmful interference to radio or television reception, which can be determined by turning the equipment off and on, the user is encouraged to try to correct the interference by one or more of the following measures:

- Reorient or relocate the receiving antenna.
- Increase the separation between the equipment and receiver.
- Connect the equipment into an outlet on a circuit different from that to which the receiver is connected.
Consult the dealer or an experienced radio/TV technician for help.

Only RS232C serial cable in the set should be connected to the camera and a PC.

FCC statement

This device complies with Part 15 of FCC rules. Operation is subject to following two conditions:

- (1) This device may not cause harmful interference, and
- (2) This device must accept any interference received, including interference that may cause undesired operation.

This Class B digital apparatus meets all requirements of the Canadian Interference-Causing Equipment Regulations.

Cet appareil numérique de la classe B respecte toutes les exigences du Règlement sur le matériel brouilleur du Canada.

WARNINGS

- The lithium battery must only be replaced with a lithium battery model number CR2025 [3V]. Use of another lithium battery may present the risk of fire or explosion.
- Keep the batteries away from children.
- If a battery is swallowed, see a doctor immediately.
- Dispose of used lithium batteries promptly, in a safe manner that complies with all applicable laws.
- The lithium battery may present the risk of fire or chemical burn if mishandled.
- Do not recharge, disassemble, heat above 100°C (212 °F) or dispose of in the fire.
- Before use, wipe the battery clean with a dry soft cloth to assure good contact.
- Never use metallic tweezers to hold the battery, and never short circuit the (+) and (-) sides of the battery.

Windows is a trademark of Microsoft Corporation.

Macintosh is a registered trademark of Apple Computer Inc.

All other brand names and product names are registered.

Legal and other notices

- All contents of this publication are subject to change without notice.
- Although the contents of this publication have been carefully checked to avoid errors, some may still occur. If you are in doubt about any points or find mistakes or omissions, please contact us.
- No part of this publication may be reproduced or reprinted except for personal use without the prior permission of Olympus.
- Olympus makes no representations or warranties regarding any damages, or benefit expected by using this unit lawfully, or any request from a third person, which are caused by the inappropriate use of this unit.
- Olympus makes no representations or warranties regarding any damages or any benefit expected by using this unit lawfully which are caused by erasing the picture data.
- The quality of the picture taken with this camera is different from the quality of a picture taken with a conventional compact camera.

OLYMPUS OPTICAL CO.,LTD.

FOR SAFE USE

Thank you for purchasing the Olympus digital camera. Before you start to use your new camera, please read these instructions carefully to obtain optimum performance and a longer service life from the unit. Be sure to retain this manual for future reference.



Warning: Ignoring this Warning mark and operating this product incorrectly may lead to serious injury or death.



Caution: Ignoring this Caution mark and operating this product incorrectly may lead to injury.



WARNINGS

1. NEVER TRY TO USE THE FLASH WHEN TAKING PICTURES OF PEOPLE (ESPECIALLY INFANTS) AT CLOSE RANGE. THE CAMERA'S FLASH MAY DAMAGE THE SUBJECT'S EYES AT CLOSE RANGE. DO NOT TAKE PICTURES OF CHILDREN FROM A DISTANCE OF LESS THAN ONE METER (ABOUT THREE FEET).
2. DO NOT AIM YOUR CAMERA DIRECTLY AT THE SUN OR OTHER EXTREMELY BRIGHT SUBJECTS. DOING SO MAY DAMAGE YOUR EYES.
3. DO NOT USE THIS CAMERA IN THE VICINITY OF FLAMMABLE OR EXPLOSIVE GAS.
4. DO NOT LEAVE THIS CAMERA WITHIN THE REACH OF INFANTS OR CHILDREN.
 - THE CHILD MIGHT PUT THE STRAP AROUND HIS OR HER NECK. THIS COULD CAUSE STRANGULATION OR CHOKING.
 - THE CHILD MIGHT SWALLOW BATTERIES OR SMALL ATTACHMENTS. IF THIS HAPPENS, CONTACT A PHYSICIAN IMMEDIATELY.

- THE CHILD MIGHT ACTIVATE THE FLASH FROM TOO CLOSE AND CAUSE DAMAGE TO HIS OR HER EYES.
 - THE CHILD MIGHT DAMAGE THE CAMERA.
5. BATTERY FLUID MAY LEAK, GENERATING HEAT AND POSSIBLY CAUSING A FIRE OR EXPLOSION.
- DO NOT USE UNSPECIFIED BATTERIES.
 - DO NOT THROW BATTERIES INTO A FIRE, OR EXPOSE TO HEAT.
 - DO NOT DISASSEMBLE THE UNIT WITH BATTERIES INSIDE.
 - DO NOT USE NEW BATTERIES AND OLD BATTERIES TOGETHER. DO NOT MIX DIFFERENT TYPES OF BATTERIES OR DIFFERENT MANUFACTURERS' BATTERIES.
 - DO NOT CHARGE ALKALINE AND LITHIUM BATTERIES. IT IS NOT POSSIBLE TO CHARGE THESE TYPES OF BATTERIES.
 - KEEP UNLOADED BATTERIES OUT OF THE REACH OF INFANTS AND CHILDREN. IF AN INFANT OR CHILD SWALLOWS THE BATTERIES, CONTACT A PHYSICIAN IMMEDIATELY.
 - DO NOT LOAD THE BATTERIES IN THE OPPOSITE DIRECTION TO THAT SHOWN IN THIS INSTRUCTIONS.

6. DO NOT STORE THE CAMERA IN HUMID OR DUSTY PLACES. THIS MAY CAUSE FIRE OR ELECTRIC SHOCK

7. DO NOT COVER THE FLASH WITH YOUR HAND DURING OPERATION. DO NOT TOUCH THE FLASH AFTER FIRING IT CONTINUOUSLY. YOU MAY GET BURNED.

8. IF YOU DROP THE CAMERA IN WATER OR GET WATER INSIDE IT, UNLOAD THE BATTERIES IMMEDIATELY AND CONTACT YOUR NEAREST OLYMPUS SERVICE CENTER. LEAVING BATTERIES IN A WET CAMERA MAY CAUSE FIRE OR ELECTRIC SHOCK.



CAUTIONS

- 1. IF YOU NOTICE AN UNUSUAL SMELL, NOISE, OR SMOKE EMITTING FROM THIS CAMERA, UNLOAD THE BATTERIES CAREFULLY TO AVOID BEING BURNED. CONTACT YOUR NEAREST OLYMPUS SERVICE CENTER IMMEDIATELY.**
- 2. NEVER ATTEMPT TO DISASSEMBLE THIS CAMERA. IT CONTAINS HIGH-VOLTAGE CIRCUITRY THAT MAY CAUSE ELECTRIC SHOCK AND INJURY.**
- 3. UNLOAD THE BATTERIES WHEN NOT USING THE CAMERA FOR LONG PERIODS. BATTERY HEAT GENERATION OR FLUID LEAK MAY CAUSE A FIRE OR INJURY.**
- 4. DO NOT USE THE CAMERA IF THE BATTERY FLUID HAS LEAKED. LEAKED BATTERY FLUID MAY CAUSE A FIRE OR ELECTRIC SHOCK. CONTACT YOUR NEAREST OLYMPUS DEALER OR OLYMPUS SERVICE CENTER.**
- 5. DO NOT OPERATE THE CAMERA WITH WET HANDS. AS YOU MAY GET AN ELECTRIC SHOCK.**
- 6. DO NOT STORE THE CAMERA IN ANY PLACE EXPOSED TO EXCESSIVE HEAT. THIS MAY WEAKEN THE PARTS OR CAUSE A FIRE.**

CARE AND STORAGE

HANDLING

- This camera is built with precision electric parts. To avoid malfunctions or mechanical problems, do not use or store the camera in the following places:
 - Places exposed to direct sunlight (a beach in summer, for example).
 - Places exposed to excessive heat, humidity, or extreme variations of temperature and humidity.
 - Places exposed to sand or dust.
 - Near a fire.
 - Near any volatile materials.
 - Near a heater, cooler, or humidifier.
 - Places exposed to excessive moisture.
 - Places exposed to vibrations.
 - Inside a car.
 - Near magnetic field.
- Do not shake or shock the camera.
- Do not leave the camera with its lens pointing towards direct sunlight. This will damage the lens.
- Do not leave the camera unused for a long period of time. This may cause battery leakage. In addition this can lead to problems including the growth of mold in the camera. Before using the camera, press the shutter release button to check operation.
- Do not turn the camera when it is mounted on a tripod.
- Do not touch any of the camera's internal parts.
- Do not use the flash for extended periods as this can cause the flash to become excessively hot. Do not touch the flash when it is hot.

BATTERY HANDLING

- This camera uses four AA alkaline batteries. AA NiCd batteries or AA nickel hydrochloride batteries or AA lithium batteries can also be used, but the battery check function will not function correctly.
- Do not use 3 V manganese batteries. Besides shortening battery life, manganese batteries may overheat and damage the camera.
- Use the batteries correctly. Incorrect use of batteries can cause fluid leak, heat generation, or other damage. When replacing batteries, be sure to load them correctly.
- The batteries may be temporarily disabled when exposed to cold temperatures. Try to keep the camera and batteries warm when using the camera in a cold environment. Batteries that are weak in cold temperatures will be restored under normal temperatures.
- Sweat, oil, and so on, can prevent a battery's terminals from making electrical contact. To avoid this, wipe both terminals before loading battery.
- Keep spare batteries on hand when going on a long trip. New batteries may be difficult or impossible to obtain abroad.
- When you use NiCd batteries and nickel hydrochloride batteries, make sure they have all been fully charged in the same battery charger.
- Use NiCd batteries and nickel hydrochloride batteries only after having carefully read the instructions accompanying them.

CHECK THE CONTENTS

Camera

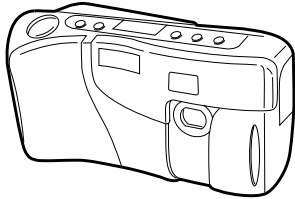

Strap

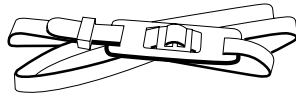

Instructions
Warranty card
User's card

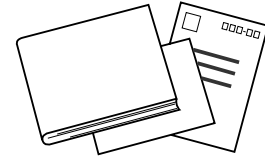

AA alkaline
batteries
(4 pieces)

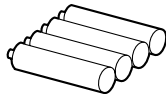

Lithium battery
(CR2025 x 1 piece)



Windows / Macintosh package includes:

- 232C PC serial cable
- Conversion connector for Windows
- Conversion connector for Macintosh
- CD-ROM software for Macintosh & Windows
- 3.5" floppy disk software
(for Windows 95 / Windows 3.1)
- 3.5" floppy disk software for Macintosh

Option

- AC adaptor

MAIN FEATURES

- **Portable, battery-powered, lightweight, compact design.**
 - **In addition to an optical viewfinder, an LCD monitor is provided for more flexibility when composing shots and viewing image.**
 - **The highest performance wide-angle lens in its class, offers you the same ease of use as a conventional compact camera.**
 - **810,000-pixel CCD delivers the highest quality pictures in its class. (D-300L only)**
-

- ▶ **“Make sure”** indicates items to be double checked.
- ▶ **“Note”** indicates other information you should be aware of.
- ▶ Actual product may differ slightly from that shown in illustrations.

CONTENTS

PREPARATIONS

Names and functions of parts	16
Using the strap	18
Loading the batteries.....	19
Loading the lithium battery	19
Turning on and checking the batteries	20
Checking the number of remaining pictures.....	21
Points to remember	22

TAKING PICTURES

Taking pictures.....	24
Using the focus lock (D-300L only)	27
Autofocus (D-300L only)	28
Selecting the resolution.....	29
Using the flash modes.....	30
Auto-Flash	31
👁 Red-Eye Reducing Flash	31
🚫 Off (flash override).....	32
⚡ Fill-In Flash (forced activation)	32
Macro mode	33
Working range.....	33
Self-timer	34
Setting the beep sound	34

DISPLAYING PICTURES ON THE LCD MONITOR

Turning on the LCD monitor.....	35
Displaying pictures	36
Protection	36
Erasing pictures	37
Slide-Show mode	39
Multi-Display mode.....	39
Adjusting the date and time.....	40

TRANSFERRING IMAGES TO A PERSONAL COMPUTER

Personal computer environment	41
Installing provided software.....	42
Connecting to a personal computer	44
Using the household power supply (Optional)	45
System chart	46

OTHERS

Questions and answers.....	47
Troubleshooting	48
Notes on display backlights.....	52
Specifications	53

PREPARATIONS

NAMES AND FUNCTIONS OF PARTS

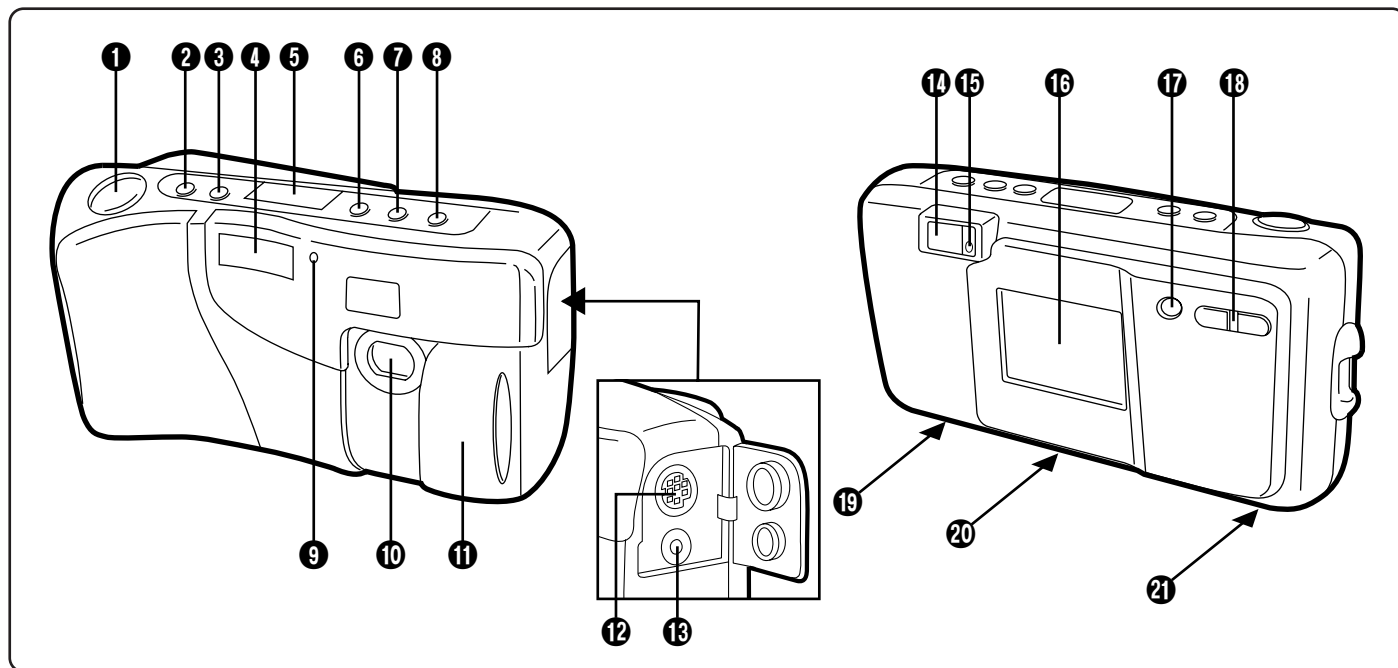

Main Unit

- ❶ Shutter release / Erase OK button P. 23
- ❷ Flash mode button P. 30
- ❸ Erase mode button P. 37
- ❹ Flash P. 30
- ❺ Control panel P. 17
- ❻ Self-timer / Slide-Show button P. 34/39
- ❼ Macro mode / Protect mode button P. 33/36
- ❽ Resolution selection / Multi-Display button P. 29/39
- ❾ Self-timer signal P. 34
- ❿ Lens
- ⓫ Lens cover P. 20
- ⓬ Computer terminal P. 44
- ⓭ DC input terminal P. 45
- ⓮ Viewfinder P. 17
- ⓯ Green lamp P. 17
- ⓰ LCD monitor P. 17
- ⓱ LCD monitor ON/OFF/PLAY button P. 26/35
- ⓲ Previous (-) / Next (+) button P. 36/39
- ⓳ Lithium battery compartment cover P. 19
- ⓴ Tripod thread P. 34
- ⓵ Battery compartment cover P. 19

Viewfinder Display

Close-up correction marks (p. 33)

Autofocus mark* /
Backlighting correction
mark (p. 27/31)

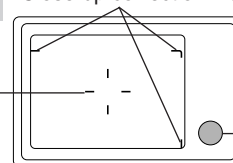

Green lamp

* Autofocus available only with D-300L.

Control Panel / LCD monitor

• Control Panel Icons

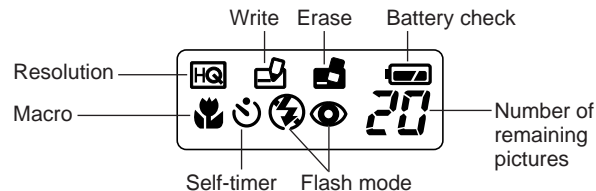

• LCD Monitor Icons

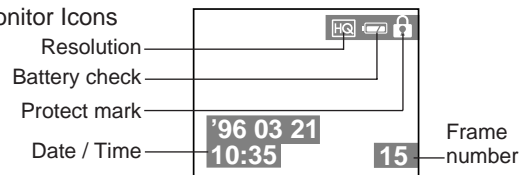

USING THE STRAP

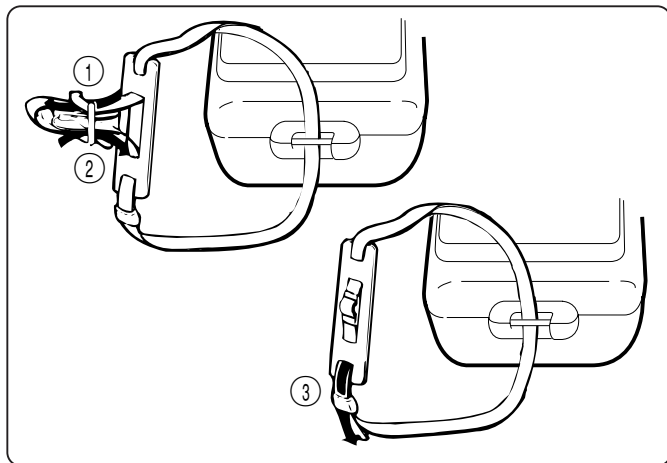

Caution:

- ◆ Attach the strap correctly as shown on the left so that the camera does not fall off. If the strap is attached incorrectly and the camera comes loose and falls off, Olympus is not responsible for any damage.

LOADING THE BATTERIES

Use four AA alkaline batteries, four AA NiCd batteries, four AA nickel hydride batteries or four AA Lithium batteries. Manganese battery cannot be used.

Read "Battery Handling" on Page 12.

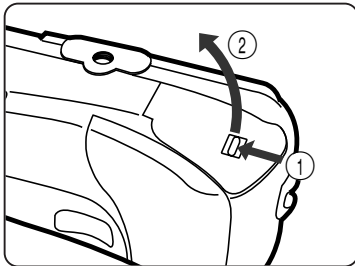

- 1 Slide the battery compartment cover to the left ① and pull the lid upward ②.

<Make sure>

▶ The lens barrier is closed and the camera is turned off before loading the batteries.

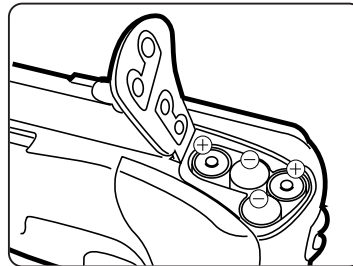

- 2 Insert the new batteries correctly as shown and close the battery compartment cover tightly.

LOADING THE LITHIUM BATTERY

Use a pointed instrument such as a ballpoint pen to open the lithium battery compartment cover. Load the lithium battery as shown and then close the cover until you hear it click into place.

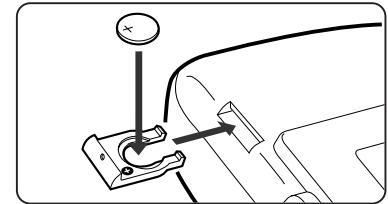

⚠ Cautions:

- ◆ Be sure to insert the batteries as directed.
- ◆ Do not use manganese batteries. Besides shortening battery life, manganese batteries may overheat and damage the camera. Use only the types of batteries specified in this manual.
- ◆ Keep the lithium battery and lithium battery holder out of the reach of children. If a child swallows the battery or cover, contact a doctor immediately.
- ◆ Do not put any foreign substances such as metal in the camera. Doing so damage the camera.

TURNING ON THE CAMERA AND CHECKING THE BATTERY

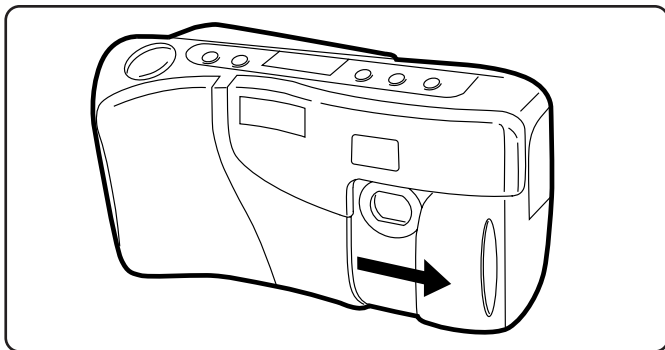

To turn on the camera, slide open the lens cover as shown. Remaining battery power and remaining pictures are indicated on the control panel.



<Make sure>

- ▶ If you do not operate the camera for three minutes, the power save function activates and the power turns off automatically.
- ▶ To turn on again, close and open the lens cover or depress the shutter release button halfway.

When you turn on the power, battery status is indicated as below.

Display	Meaning
 lights and turns off automatically.	Batteries are OK. You can shoot.
 blinks and other indicators on the control panel are displayed normally.	Battery power is low and batteries should be replaced.
 blinks and other indicators on the control panel go out.	Batteries are dead and should be replaced immediately.

Note:

- ◆ **Keep spare batteries on hand when going on a long trip or to a wedding for example, or when using the camera in cold weather.**

CHECKING THE NUMBER OF REMAINING PICTURES

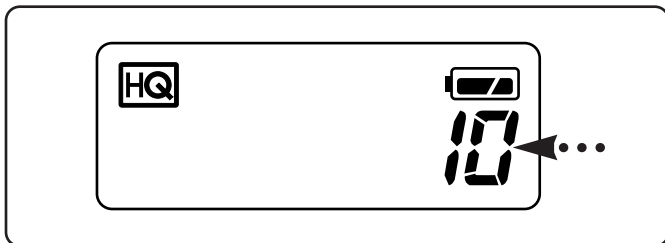

When you turn on the power, the number of remaining pictures is shown on the control panel.

• Maximum number of storage pictures

	D-300L	D-200L
High Quality mode	30	20
Standard Quality mode	120	80

Note:

- ◆ After checking the number of remaining pictures, be sure to set and adjust the date and time by connecting the camera to a computer.

- When the number of remaining pictures is 0, the camera emits a long single beep and the green lamp blinks. If the memory is full, the camera beeps whenever the lens cover is opened.
- When the number of remaining pictures is less than 3 in the Standard Quality mode, shooting is not possible in the High Quality mode. (See Page 29.)

<Make sure>

- ◆ The number of remaining pictures varies depending on the Resolution setting. For example, if the remaining count is 4 in the Standard Quality mode, it will be 1 in the High Quality mode.
- ◆ We recommend that you download the pictures you've already taken to a personal computer as soon as possible (see Page 42), and erase pictures stored in the camera on a regular basis (see Page 37).

POINTS TO REMEMBER

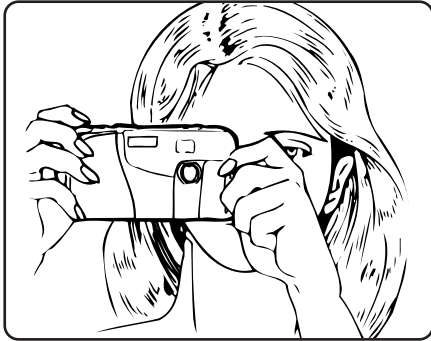

Correct.

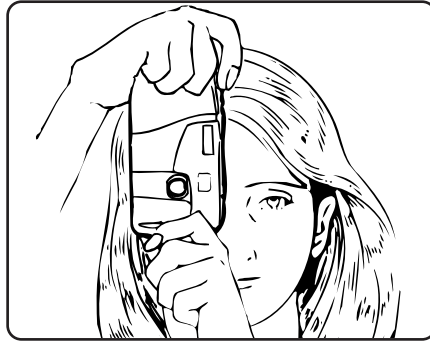

Correct.

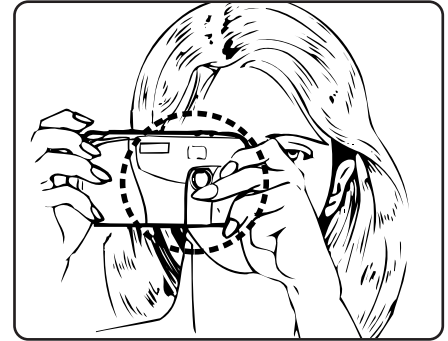

Incorrect.

<Make sure>

- ▶ Hold the camera firmly with both hands while keeping elbows at sides to prevent the camera from shaking.
- ▶ When holding the camera vertically, hold the camera with its flash positioned at the top.

Note:

- ◆ Keep your fingers and the strap away from the lens and flash.

Proper Shutter Release

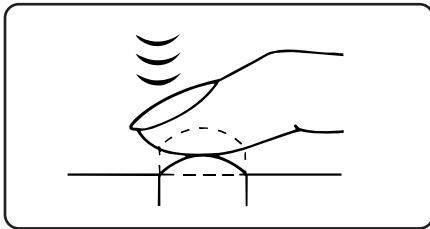

- 1** Depress the shutter release button halfway.

<Make sure>

- ▶ The green lamp next to the viewfinder lights.
- ▶ The exposure will be locked.
- ▶ With the D-300L, the focus will be adjusted.

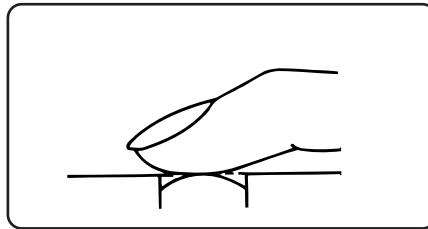

- 2** Depress the shutter release button fully to release the shutter, and take the picture.

<Make sure>

- ▶ The Writing indicator on the control panel blinks, and the green lamp next to the viewfinder blinks.

Note:

- ◆ Press the shutter release button gently. Avoid shaking the camera when pressing the shutter release button to prevent blurry pictures.

TAKING PICTURES

TAKING PICTURES

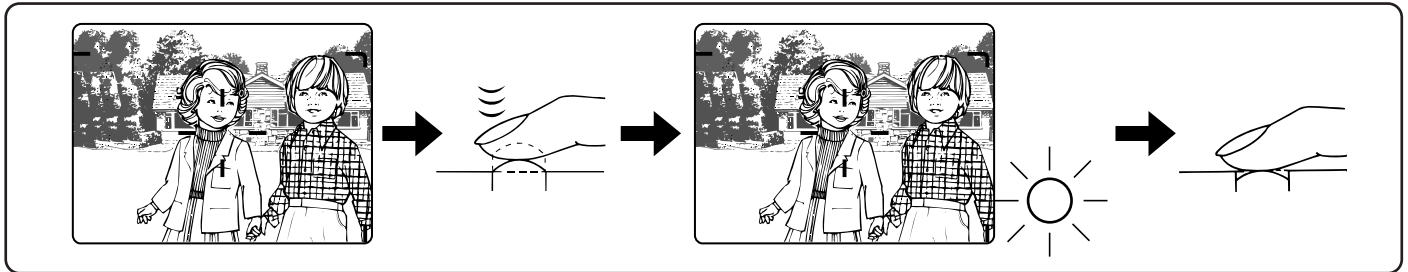

Taking pictures using the optical viewfinder

1 Compose the picture using the optical viewfinder.

 **Caution:**

◆ **Do not unload the batteries while the Writing indicator is blinking. Not only will the picture you have just taken be lost, but stored pictures may also be damaged.**

2 Depress the shutter release button halfway. The green lamp lights.

3 Depress the shutter release button fully to take the picture.

4 The camera emits two short beeps to indicate that the shot has been taken.

5 When the Writing indicator on the control panel or the green lamp next to the viewfinder stops blinking, the camera is ready to take next picture. (The Writing indicator will disappear after about 6 seconds in the High Quality mode and in about 2 seconds in the Standard Quality mode.)

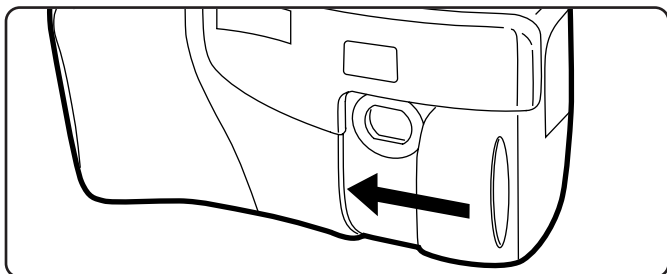

- 6** When you close the lens barrier, all control panel indications disappear and the power turns off.
- Even after turning off the power or replacing the batteries, pictures remain stored in memory.

Note:

- ◆ When the camera is being operated on battery power and the batteries are running low, the camera may emit several short beeps and blink the number of remaining pictures on the control panel after you take

Note:

- ◆ It is also possible to take pictures using the LCD monitor as a viewfinder. However, it is better to use the optical viewfinder since the camera is less likely to shake and pictures are easier to take. Refer to Page 26 for details on taking pictures using the LCD monitor.

- Whenever the Writing indicator is blinking, it means that the camera is still processing the image. If you press the shutter release button while the indicator is blinking, the shutter won't release.

a shot. If this happens, the picture you have just taken may not turn out properly. Replace the batteries and take your picture again.

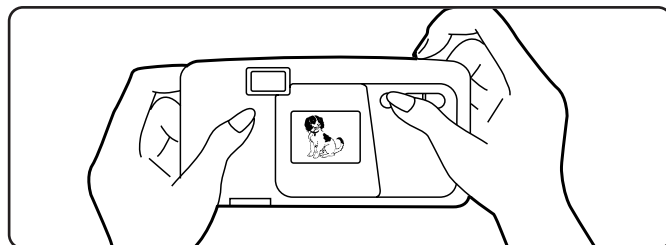
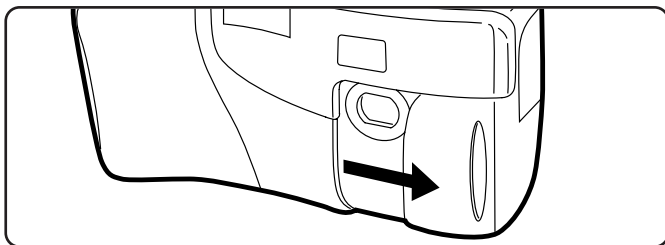

Taking pictures using the LCD monitor

- 1** Open the lens barrier. Press and hold the LCD monitor ON/OFF (green) button to turn on the LCD monitor's display.



Caution:

- ◆ Do not touch the surface of the LCD monitor. This can leave a blur on the monitor. Pushing too hard on the monitor may break it.

- 2** Aim the camera by looking at the subject through the LCD monitor.

Note:

- ◆ Pictures that appear on the LCD monitor are for composition purposes only — regardless of whether it is used as a viewfinder or a display monitor. They do not show such information as focus or exposure. If you need to know this information, transfer pictures to your computer's display monitor.

<Make sure>

- ◆ Take the picture in the same way as you would when using the optical viewfinder. (See Page 24.)
- ◆ When using the LCD monitor, keep the LCD monitor ON/OFF (green) button pressed while taking pictures.

USING THE FOCUS LOCK (D-300L ONLY)

The D-300L features a convenient autofocus function. If your main subject is not within the autofocus marks, use the procedure below to obtain focus. This is called focus lock.

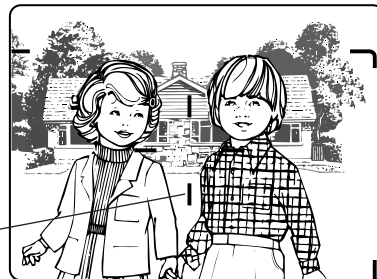
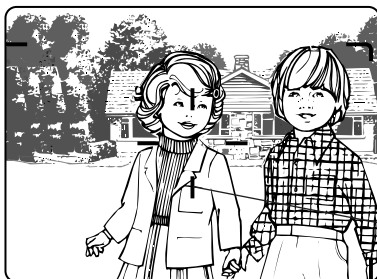

Autofocus marks

1 Position your subject within the autofocus marks and press the shutter release button halfway.

2 Reposition your subjects in the picture frame while keeping the shutter release button depressed halfway. Then press the shutter release button fully.

<Make sure>

▶ The green lamp next to the viewfinder lights.

Note:

● When the focus is locked, the exposure is also locked (AE lock).

AUTOFOCUS (D-300L ONLY)

Although the D-300L's autofocus can lock on virtually any subject, there are certain conditions, such as ❶ ~ ❸ shown below, where it may not be possible to obtain the correct focus. In the situations shown below in ❹ ~ ❺, autofocus may not lock on the correct subject even though the green lamp lights and the shutter releases.

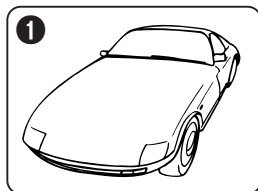

Subjects with low contrast

- Use the focus lock by first focusing on something at the same distance as the subject you wish to take a picture of, and then aim at the subject.

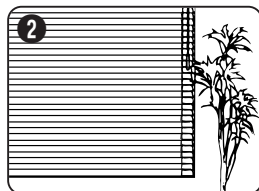

Subjects that do not contain vertical lines

- Use the focus lock first while holding the camera vertically. Then switch the camera to the horizontal position to take the photograph.

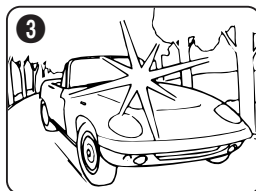

Subjects in excessively bright light

- Use the focus lock by first focusing on something at the same distance as the subject you wish to take a picture of, and then aim at the subject.

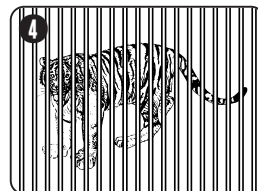

Two subjects at different distance

- When the subject looks out-of-focus even though the green lamp lights, focus on another subject at the desired camera-to-subject distance first. Then recompose the frame to take the picture.

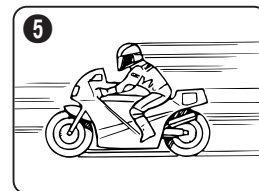

High-speed subjects at close range

- Focus on another subject at the desired camera-to-subject distance first. Then recompose the frame to take the picture.

SELECTING THE RESOLUTION

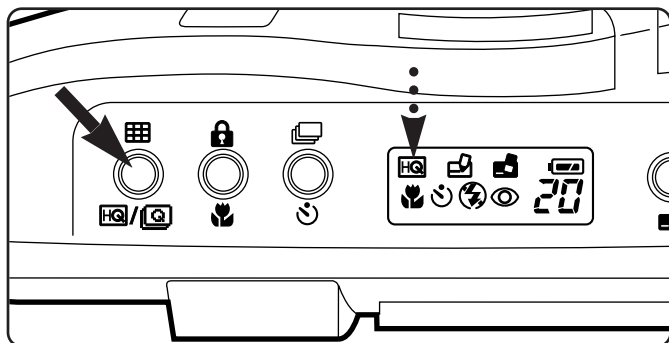

This camera has two levels of resolution — the High Quality mode and the Standard Quality mode.

Press the Resolution selection button to choose either mode.

When using the High Quality mode

(HQ is indicated on the control panel.)

1024 x 768 pixels (D-300L)

640 x 480 pixels (D-200L)

When using the Standard Quality mode

(No indication on the control panel)

512 x 384 pixels (D-300L)

320 x 240 pixels (D-200L)

<Make sure>

- ▶ The selected resolution mode remains the same even when the camera is switched off. The mode returns to High Quality or Standard Quality when the batteries are replaced.
- ▶ The number of remaining frames varies according to the resolution mode. In the Standard Quality mode, four times as many pictures can be taken as in the High Quality mode.

USING THE FLASH MODES

This camera has four flash modes. Select the flash mode according to your shooting conditions and needs.

How to select the flash mode:

As you press the Flash mode button, the mode switches as shown on the right. The selected flash mode is displayed on the control panel.

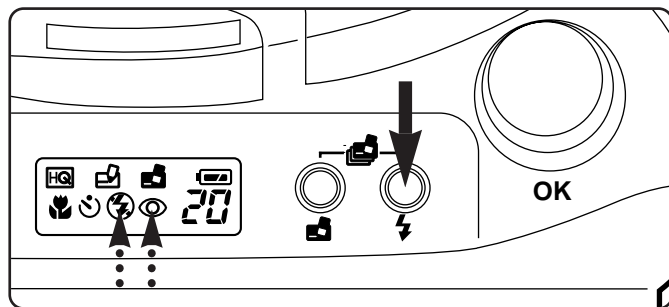

Note:

When the green lamp is blinking, it means the flash is being recharged. The shutter won't release while the flash is recharging, so remove your finger from the shutter release button and wait for several seconds.

The Red-Eye Reducing Flash mode is not canceled when the power is turned off. If any other mode is set, the camera returns to the Auto-Flash mode.

	(No icon) AUTO-FLASH mode Automatically fires in low-light and backlight conditions. (p. 31)
	RED-EYE REDUCING FLASH mode Significantly reduces the phenomenon of "red-eye" (when a subject's eyes appear red in flash photos). (p. 31)
	OFF mode The flash does not fire. (p. 32)
	FILL-IN FLASH mode Fires regardless of available light. (p. 32)

Flash Working Range

D-300L	0.2 m ~ 2.4 m (0.65 ~ 7.9 ft.)
D-200L	0.2 m ~ 3.5 m (0.65 ~ 11.5 ft.)

AUTO-FLASH

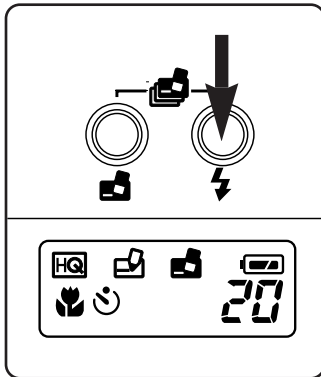

In the Auto-Flash mode, the flash will fire automatically in low-light and backlight conditions.



Backlighting correction mark

When you take a picture on the backlight, set the subject on the backlighting correction marks to fire a flash.

RED-EYE REDUCING FLASH

Significantly reduces the phenomenon of “red-eye” (when a subject’s eyes appear red in flash photography).



In the Red-Eye Reducing Flash mode, the camera will emit a series of low-power pre-flashes before the regular flash. This makes the subject’s pupils contract, significantly reducing red-eye. Except for the pre-flashes, this mode is the same as the Auto-Flash mode.

Notes:

- ◆ Be sure to hold the camera still until the shutter releases. This takes about one second.
- ◆ Red-eye reduction may not be effective when the subject:
 - Is not looking at the flash from the front.
 - Is not watching the pre-flashes.
 - Is too far from the camera.
 - Does not respond to the pre-flashes due to particular individual characteristics.
 - Some medications, alcohol or drugs may interfere with the red-eye reduction process.

OFF (FLASH OVERRIDE)



When you don't want the flash to fire even in the dark or when you want to shoot such subjects as fireworks.

In the Off mode, the flash does not fire even in low-light conditions. Use this mode in situations where flash photography is not desired or is prohibited or in twilight or night scenes.

Note:

- ◆ Since a slow shutter speed (down to 1/8 seconds) is automatically selected in low-light situations when in the Off mode, the use of a tripod is recommended to prevent blurred pictures caused by camera shake.

FILL-IN FLASH (FORCED ACTIVATION)



When you want the flash to fire all the time.

In the Fill-In Flash mode, the flash fires regardless of available light. For example, this mode can be used to brighten up a subject's shaded face or under artificial lighting such as back-light, fluorescent light.

<Make sure>

- ◆ Use this mode within the flash working range (Page 30). It may not work well under excessively bright light.

MACRO MODE

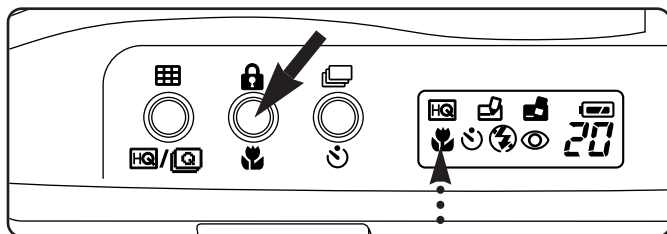

Use the Macro mode to take pictures of small subjects at a very close distance.

A picture of an A5-size subject can be taken fully within the frame. (Size – 4.1 x 5.8 inches)

Each time you press the Macro mode button, the mode switches between Standard mode and Macro mode.

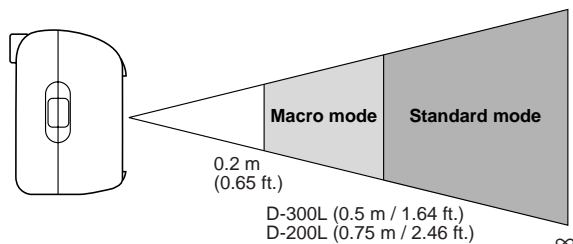

WORKING RANGE

Close-up Correction

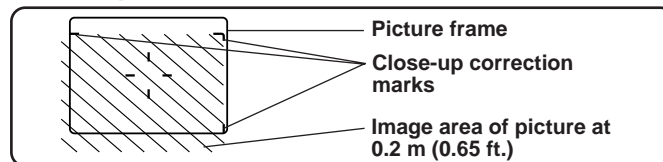

The viewfinder's picture frame shows the area that can be shot for subjects at ∞ . However, the picture area will move lower in the viewfinder as you get closer to the subject. At 0.2 m (0.65 ft.), the shaded area is the actual available image area. In this case, the subject should be positioned below the close-up correction marks.

Take pictures at the distance between 0.2 m ~ ∞ (0.65 ft. ~ ∞).

- Subjects closer than 0.2 m (0.65 ft.) will be out of focus and incorrectly exposed.
- When you take pictures using the LCD monitor as a viewfinder, the image you see is the same as what will be recorded. This makes it easier to take close-up pictures.

Working range

Mode	D-300L	D-200L
Macro mode	0.2 m ~ 0.5 m (0.65 ~ 1.64 ft.)	0.2 m ~ 0.75 m (0.65 ~ 2.46 ft.)
Standard mode	0.5 m ~ ∞ (1.64 ft. ~ ∞)	0.75 m ~ ∞ (2.46 ft. ~ ∞)

SELF-TIMER

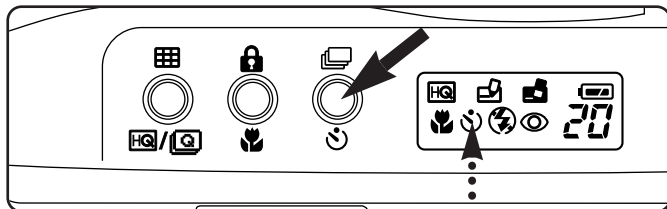

- 1 Press the Self-Timer button. The Self-Timer indicator is displayed on the control panel.
 - Use a tripod to hold the camera securely.
- 2 Aim at your subject, and press the shutter release button.
 - The shutter will be released about 12 seconds after the shutter release button is pressed.

<Make sure>

- ▶ The focus (D-300L only) and exposure lock when the shutter release button is depressed halfway.
- ▶ The Self-Timer is disengaged when the shutter is released.
- ▶ To cancel the Self-Timer after it has been activated, press the Self-Timer button again or close the lens cover.

SETTING THE BEEP SOUND

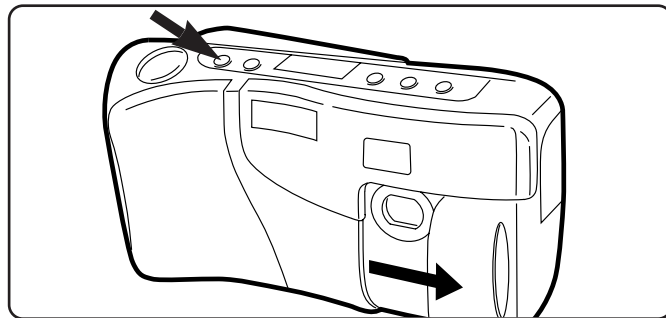

How to set the beep sound

Press and hold the Flash mode button and open the lens cover at the same time.

- If you hear a single beep, the beep sound is set to ON.
- If the camera makes no sound, the beep sound is set to OFF.

<Make sure>

- ▶ The beep sound setting is not affected when the batteries are unloaded.

DISPLAYING PICTURES ON THE LCD MONITOR

TURNING ON THE LCD MONITOR

After taking a picture, you can immediately view it on the LCD monitor.

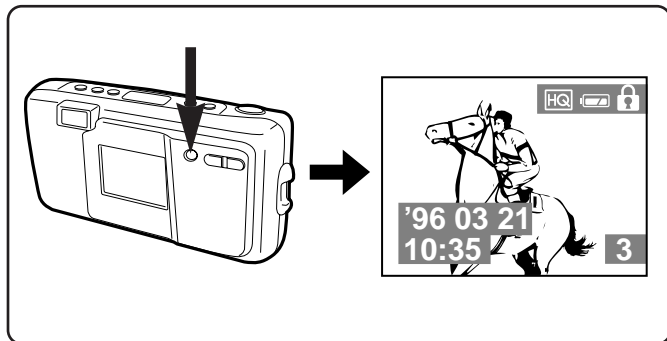

Close the lens cover and press the LCD monitor ON/OFF (green) button to turn on the LCD monitor.

- The last picture taken is displayed on the LCD monitor. The frame number, and battery remaining indicators are also displayed. If you set the Date, Resolution or Protection mode while viewing pictures, these are also shown. If you have not taken any pictures, a blank blue screen is displayed.

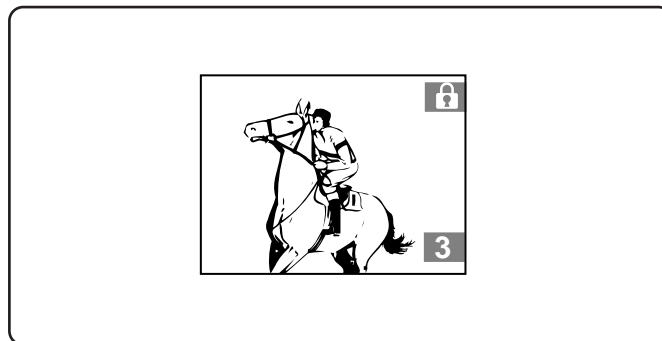

- Resolution, Battery Remaining and Date indicators will disappear after about three seconds. If the batteries are low, the low-battery indicator appears and blinks.
- High Quality mode pictures take approximately six seconds to come up on the LCD monitor.

DISPLAYING PICTURES

You can display the pictures you have taken on the LCD monitor.

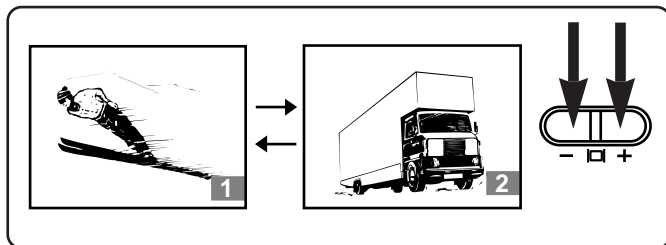

This function works when the lens cover is closed.

- 1 Press the Previous (-) button to see the previous frame. Each time you press the Previous (-) button, the preceding frame will appear.
- 2 Press the Next (+) button to see the next frame.
 - Each time you press the Next (+) button, the succeeding frame will appear.
 - Wait until the picture is fully displayed before pressing any buttons.
 - If similar pictures have been taken consecutively, the LCD may not appear to change.

PROTECTION

You can prevent accidental erasure of frames you want to keep.

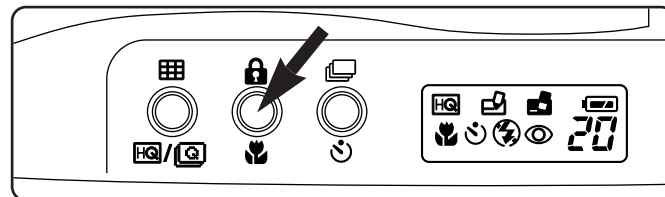

This function works when the lens cover is closed.

- 1 Display the frames and select the frame you want to keep.
- 2 Press the protect button to protect the selected frame.
 - The Protect indicator appears in the upper right corner of the LCD monitor.
- 3 To cancel protection, press the protect button again.
 - The protected frame cannot be deleted until you press the Protect button again.
 - Protection and its cancellation are also possible in the Multi-Display mode (see page 39).

ERASING PICTURES

You can delete pictures you don't want.

If the frame you want to delete is protected, you cannot start the erasing operation. Cancel the protection first before starting the erasing operation.

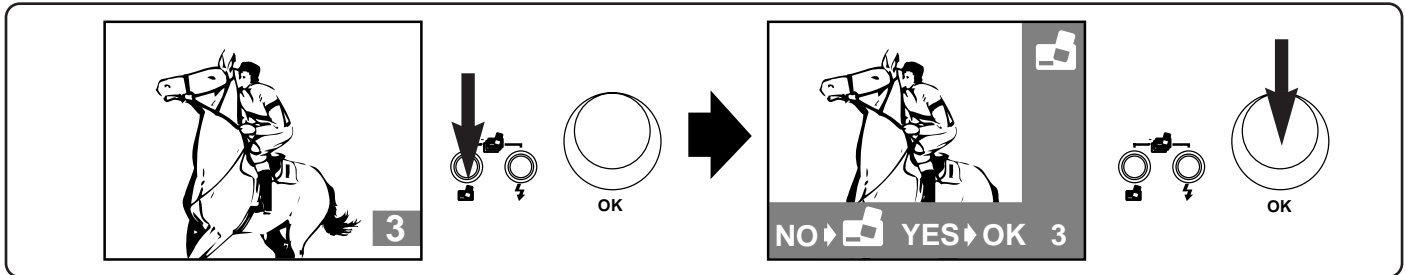

One-Frame Erase

This function works when the lens cover is closed.

- 1 Display the frame you want to delete.
- 2 Press the Erase mode button until the One-Frame Erase indicator in the upper right corner of the LCD monitor lights.
 - To cancel, press the Erase mode button again.
 - Do not press the Erase mode button while an image is being loaded onto the LCD.

- 3 Press the Erase OK (Shutter Release) button to erase the selected frame.
 - The camera makes a short single beep and the selected frame is erased. The previous frame will now be displayed.



Caution:

- ◆ Do not unload batteries while erasing frames as this may result in all frames being erased.



All-Frame Erase

This function works when the lens cover is closed.

- 1** Display a picture.
- 2** Press the Erase mode button and Flash button simultaneously, the All-Frame Erase indicator lights in the upper right corner of the LCD monitor.
 - To cancel, press the Erase button again.
- 3** Press the Erase OK (Shutter Release) button to erase all frames.
 - The camera makes a short single beep and the All-Frame Erase indicator starts descending.

- 4** After several seconds all frames are erased. The blue background display will appear on the LCD monitor.
 - If there are any protected pictures, they will not be erased and the last-taken protected picture will be displayed when the erasing operation is completed.
 - All-Frame Erase is also available in the Multi-Display mode. (See page 39.)



Cautions:

- ◆ Be careful not to erase any pictures you don't want to delete.
- ◆ Do not unload batteries while erasing frames as this may result in all frames being erased.

SLIDE-SHOW MODE

You can run through all the pictures automatically.

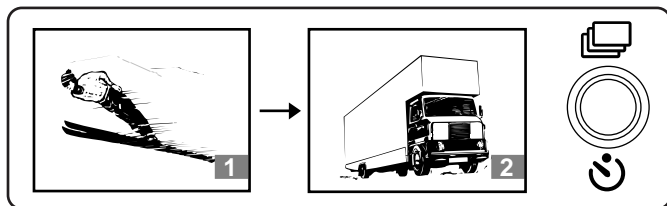

This function works when the lens cover is closed.

- 1 Display the picture.
- 2 Press the Slide-Show button to start running through the frames automatically.
 - The frame number and protect mark are displayed together with the frame on the LCD monitor.
- 3 Press the Slide-Show button again to stop at the currently displayed frame.
 - The Slide-Show mode doesn't stop until you cancel the operation. Press the Slide-Show button to cancel this mode.
 - The Slide-Show is also available in the Multi-Display mode.

MULTI-DISPLAY MODE

Nine frames are shown on the LCD monitor

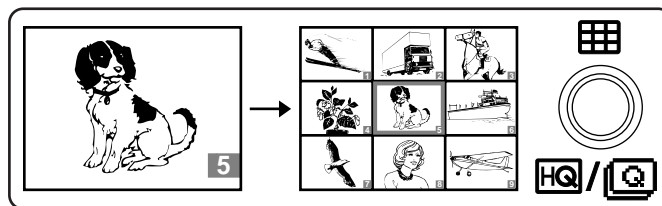

This function works when the lens cover is closed.

- 1 Display a picture.
- 2 Press the Multi-Display button. Nine frames are displayed with the currently selected frame displayed in the center.
- 3 When you press the Previous (-) button, the selected frame advances.
 - Press the Next (+) button to go backward.
- 4 After the frame in the upper-left corner of the display is selected, the next six frames are displayed. (If you are using the Next (+) button, the new frames are added when the picture in the lower-right corner is selected.)
- 5 Press the Multi-Display button to cancel the Multi-Display mode. The currently selected frame is displayed.

ADJUSTING THE DATE AND TIME

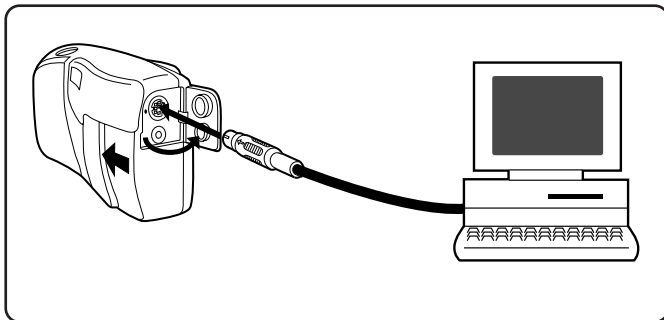

<Make sure>

- ◆ The date and time cannot be set directly on the camera.
- ◆ Whenever you replace the lithium battery, be sure to set the date and time again as soon as possible.
- ◆ We recommend that you check the date and time before taking important photographs.

- 1** Connect the camera to a personal computer.
(See Page 44.)
- 2** Start up the bundled software.
- 3** Once the program has loaded, select “Camera Settings” from the menu bar. The camera setting window appears.
- 4** Set the date and time as indicated in the camera settings window.

TRANSFERRING IMAGES TO A PERSONAL COMPUTER

PERSONAL COMPUTER ENVIRONMENT

Personal computers used with this camera must conform to the following minimum standards.

● IBM PC/AT compatible

Operating System	: Windows 95 or 3.1 CD-ROM Drive
Hard Disk Capacity	: More than 40 MB
RAM	: Windows 3.1—8 MB Windows 95—16MB
Connectors	: Standard RS-232C interface D-SUB 9-pin connector
Monitor	: Minimum 256 colors Minimum 640 x 480

● Apple Macintosh and compatible

CPU	: 68030 or later
Operating System	: MacOS™ 7.0 or higher CD-ROM Drive
Hard Disk Capacity	: More than 40 MB
RAM	: 68030/40—8 MB Power PC 601/604—16 MB
Connectors	: Standard RS-232C interface D-SUB 9-pin connector
Monitor	: Minimum 256 colors Minimum 640 x 480

Personal computers used with Adobe PhotoDeluxe™ must conform to the following minimum standards.

● IBM PC/AT compatible/Apple Macintosh and compatible

Operating System	: Windows 95 or 3.1 CD-ROM Drive MacOS™ 7.0 or higher double speed CD-ROM Drive
Hard Disk Free Space Capacity	: More than 45 MB
RAM (Minimum)	: Windows 3.1—8 MB Windows 95—16 MB 68030/40—8 MB Power PC—16 MB
RAM (Recommended)	: Adobe strongly recommends more than 16 MB of RAM. 24 to 32 MB of RAM is preferred. See the Adobe Manual for all requirements.
Connectors	: Standard RS-232C interface D-SUB 9-pin connector
Monitor	: Minimum 256 colors Minimum 640 x 480

INSTALLING PROVIDED SOFTWARE

1. Introduction

The Olympus digital camera's software is distributed on a single CD-ROM. This CD contains all the required software for the user to download images from the camera and manipulate them on your desktop computer. In addition, the software provides the user with the ability to control certain camera features and snap pictures while in a "tethered mode."

Modules are developed for the two most popular personal computer operating systems:

MS Windows

Camera Acquisition and communications Module
Adobe PhotoDeluxe for Windows / Windows 95 CD

Macintosh compatible

Camera Acquisition and communications Module
Adobe PhotoDeluxe for Macintosh (CD)

Installation of the software can follow one of several scenarios :

- User do not have any image manipulation software resident on your computer.
- User already has Adobe PhotoShop or compatible software package installed on their computer.

2. Installation

In order to download images from the camera or control the camera via the computer, you will need a software application that has either :

an Adobe PhotoShop 3.0.5 standard plug-in interface (Macintosh™), or a TWAIN v1.6 compliant interface (Windows™ / Windows 95™).

If you do not own such software, Olympus has supplied a version of Adobe PhotoDeluxe. To install Adobe PhotoDeluxe, please refer to the supplied Adobe PhotoDeluxe documentation. Documentation is found on the CD-ROM.

As mentioned, the digital camera's acquisition and communications software modules are structured as standard plug-ins for popular image manipulation software applications.

For Microsoft Windows™ systems, the Olympus digital camera's software employs the TWAIN standard to communicate with the camera.

For Macintosh™ systems, the Olympus digital camera's software employs an Adobe PhotoShop compatible plug-in module.

Installing the plug-in software

The supplied CD-ROM contains the required installation programs for both MS Windows and Macintosh systems.

The installation is straightforward and will require you to answer a few questions. Installing the software is a great time to fill out the registration card and jot down and save serial numbers and support line phone numbers.

3. Software Notes

Several features of the camera are only accessible via the host computer software modules, e.g., setting the camera's time and date, downloading images, printing images.

Please refer to the Camera Software User's Manual in order to learn more about these features.

CONNECTING TO A PERSONAL COMPUTER

Use the appropriate connector according to the platform of your computer.

• IBM PC/AT compatible

Connect the provided computer cable to the COM 1 or COM 2 serial port on your computer.

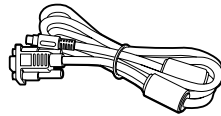

• Apple Macintosh or compatible

Attach the provided conversion connector for Macintosh to printer or modem serial port on your computer, and then connect the provided computer cable.

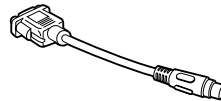

The enclosed Macintosh conversion connector allows you to connect your camera to a Macintosh computer. It cannot be used to connect a Macintosh to a printer.

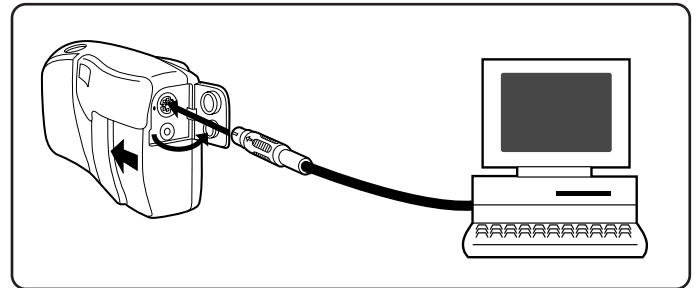

Make sure that the camera and the computer are turned off before connecting.

- 1** Connect the computer cable to the computer's serial cable as explained on the left.
- 2** Open the connector cover.
- 3** Align the arrow mark on the computer cable plug with the circle dot mark on the camera's connector. Insert the plug and push until it is in fully.
- 4** Open the lens barrier to turn on the power.

USING THE HOUSEHOLD POWER SUPPLY (Optional)

An optional AC adaptor allows you to power your digital camera from the household power supply.

Note:

- ◆ When in use for long periods, the AC adaptor will be warm to the touch. This is normal.

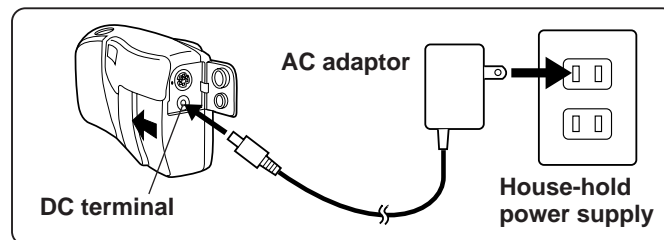

Warnings: Use the AC adaptor correctly and pay attention to the precautions below. Incorrect use of the AC adaptor may cause a fire or electric shock.

- ◆ Use an AC120V power source.
- ◆ Make sure the AC adaptor is properly plugged into the outlet.
- ◆ Do not connect or disconnect the AC adaptor with wet hands.
- ◆ If the AC adaptor's cord is hot, smells like smoke, or is emitting smoke, unplug it immediately. Contact your nearest Olympus dealer or Olympus service center.
- ◆ Do not use the optional exclusive AC adaptor with other products. Olympus can not take responsibility for the damage caused by the use of any AC adaptor other than the one exclusively designed for this camera.
- ◆ Hold the AC adaptor unit when removing it from an outlet.
- ◆ Never pull forcibly, bend, or twist the AC adaptor.
- ◆ If there are any scratches or other damage on the AC adaptor or if there is a contact failure on the plug, consult your nearest Olympus service center as soon as possible.
- ◆ When disconnecting the AC adaptor, make sure the camera is turned off.
- ◆ If batteries are loaded in the camera, make sure the camera is turned off before connecting or disconnecting the AC adaptor.
- ◆ When you are not using the AC adaptor, be sure to unplug it.

SYSTEM CHART

The following capabilities are available when connected to optional equipment.

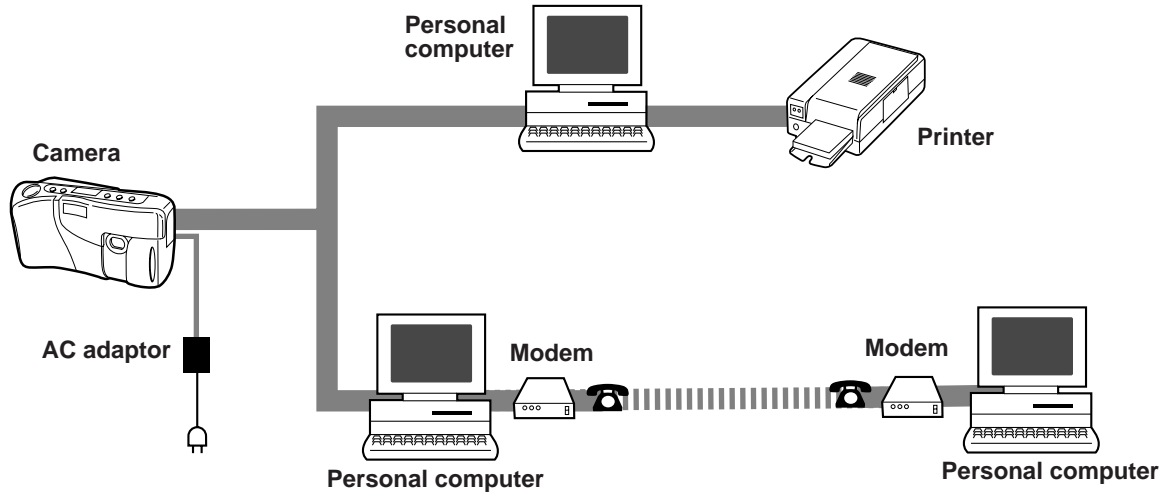

OTHERS

QUESTIONS AND ANSWERS

Q How long will the batteries last?

A Four new AA alkaline batteries may last for as many as 100 frames when the flash is used on half of all the shots (determined under Olympus test conditions). But this is just a yardstick — in actual use, battery life is affected by many variables such as the amount of LCD monitor use, the frequency of flash use, as well as by the kind of battery used and the environmental conditions under which the camera is used. Using the LCD monitor frequently will use up your batteries very quickly. Keep the LCD monitor turned off to save power.

The battery consumption figures regarding the number of pictures the camera can take are based on our tests and our designated batteries. These figures are for reference only. The actual number of pictures the camera can take on a set of batteries may vary.

For best results, use lithium AA batteries.

Q How can I correct the clock in the camera that will be used to record date on the image data?

A Date adjustment isn't made when the camera is shipped. After loading the lithium battery, connect the camera to a personal computer and use the provided application software to correct the date. The date also needs to be reset whenever the AA batteries and lithium battery are replaced at the same time.

Q How should I store the camera?

A Cameras are susceptible to damage caused by dust, moisture, and salt. Wipe and dry the camera thoroughly before storing it. After using it at the beach, wipe it with a cloth that has been moistened with fresh water and then wrung out. Do not store in an area where mothballs are used. Unload the batteries if you do not plan to use the camera for a long period.

Q Why do the subjects' eyes sometimes appear red in pictures?

A This "red-eye phenomenon" occurs with all cameras when a flash is used. It is caused by light from the flash reflecting off the retina at the back of the eye. Red-eye varies depending on the individual and the shooting conditions such as ambient lighting. Use of the Red-Eye Reducing Pre-Flash mode significantly reduces this phenomenon.

Q Can I use a filter or hood?

A No, you can't.

Q How should I clean the LCD monitor?

A Wipe the LCD monitor gently with lens cleaning tissue.

TROUBLESHOOTING

Operating Problems

Symptom	Cause	Remedy	See
The camera does not work.	<ul style="list-style-type: none"> ① The power is OFF. ② The batteries are loaded incorrectly. ③ The batteries are exhausted. ④ The batteries are temporarily unable to function. 	<ul style="list-style-type: none"> ❶ Open the lens cover to turn on the power. ❷ Reload the batteries correctly. ❸ Replace the batteries with new ones. ❹ Keep the batteries warm while using them. 	P.20 P.19 P.19
No picture is taken when the shutter release button is pressed.	<ul style="list-style-type: none"> ① The flash has not finished charging or the previous picture is being written into memory. ② Memory is full. 	<ul style="list-style-type: none"> ❶ Remove your finger from the shutter release button and wait until the green lamp stops blinking. ❷ Check the number of remaining pictures on the control panel and erase unnecessary frames using the One-Frame Erase mode. Or transfer the pictures to a computer, and erase the entire memory using the All-Frame Erase mode. 	P.30 P.21 P.37
The flash doesn't fire.	<ul style="list-style-type: none"> ① The flash mode is in the Off mode. 	<ul style="list-style-type: none"> ❶ Set the flash mode to something other than the Off mode. 	P.30
The pictures already taken can't be displayed on the LCD panel.	<ul style="list-style-type: none"> ① The lens cover is left open. ② Memory is empty. 	<ul style="list-style-type: none"> ❶ Close the lens cover and depress the LCD monitor ON/OFF (green button) to turn on the LCD monitor. ❷ Check the number of remaining pictures. 	P.21

Symptom	Cause	Remedy	See
The LCD monitor is hard to read.	① Selection of brightness is wrong.	① Connect the camera to a computer, and adjust using the provided application software.	P.42
When the camera is connected to a computer, an error message appears while data is being transferred to the computer.	① The cable is not plugged in correctly. ② The power is OFF. ③ The batteries are exhausted. ④ The serial port is not selected correctly.	① Connect the cable correctly. ② Open the lens cover to turn on the power. ③ Replace the batteries with new ones. ④ Use the operating system software to make sure the serial port is selected correctly.	P.44 P.20 P.19 P.44

Problems with Images

Symptom	Cause	Remedy	See
The picture is out of focus.	① The camera moved when the shutter button was pressed. ② The viewfinder's autofocus mark was not positioned on the subject. (D-300L only) ③ The lens is dirty.	① Hold the camera correctly, and press the shutter release button. ② Position the autofocus frame on the subject, or use the focus lock. (D-300L only) ③ Clean the lens.	P.22 P.27

Symptom	Cause	Remedy	See
The picture is out of focus.	<ul style="list-style-type: none"> ④ The mode was not selected correctly. The subject was closer than the minimum working distance to the lens (D-300L: 0.5 m/1.64 ft; D-200L: 0.75 m/2.46 ft) with the the Normal mode selected. Or the subject was farther than the minimum working distance with the Macro mode selected. ⑤ The shutter release button was pressed from right in front of the camera in the Self-Timer mode. 	<ul style="list-style-type: none"> ④ Shoot from more than the minimum working distance when in the Normal mode. Shoot from less than the minimum working distance when in the Macro mode. ⑤ Press the shutter release button while looking into the viewfinder, not while standing in front of the camera. 	P.33
The picture is too dark.	<ul style="list-style-type: none"> ① The flash was blocked by a finger. ② The subject was out of the working range of the flash. ③ The flash mode was set to the Off mode. ④ The subject was too small and backlight. 	<ul style="list-style-type: none"> ① Hold the camera correctly, keeping your fingers away from the flash. ② Shoot within the flash working range. ③ Check the flash mode before shooting. ④ Set the flash to Fill-In mode. 	<p>P.22</p> <p>P.30</p> <p>P.30</p> <p>P.32</p>

Symptom	Cause	Remedy	See
The picture is too bright.	<ul style="list-style-type: none"> ① The flash was set to the Fill-In Flash mode. ② The subject was very bright. 	<ul style="list-style-type: none"> ❶ Set the flash mode to one other than Fill-In Flash. ❷ Point the camera to avoid overly bright subjects. 	P.30
The colors of pictures taken indoors look unnatural.	<ul style="list-style-type: none"> ① The lighting fixture(s) affected the picture. 	<ul style="list-style-type: none"> ❶ Set the flash mode to Fill-In. 	P.32
The picture has obscured edge(s).	<ul style="list-style-type: none"> ① The lens was partly blocked by a finger or the strap. ② The shooting distance was too close. 	<ul style="list-style-type: none"> ❶ Hold the camera correctly, keeping your fingers and the strap away from the lens. ❷ Use the close-up compensation marks in the viewfinder. 	P.22 P.33

NOTES ON DISPLAY BACKLIGHTS

- The fluorescent lamps used in the Control Panel and LCD monitor have a limited service life. If either LCD monitor begins to darken or flicker, contact your nearest service center. (There will be a fee for this service.)
- In cold conditions, the display backlight may be slow to come on or may change color suddenly. To avoid this, try to keep the camera warm when using it in cold temperatures. Backlight performance will return to normal under normal temperature conditions.

SPECIFICATIONS

Product type : Digital still camera (for shooting and display)

Recording System: Digital recording

Internal Memory : Built-in flash memory

D-300L : 6 MB

D-200L : 2 MB

No. of storable frames

D-300L : 30 pictures (High Quality mode)

120 pictures (Standard Quality mode)

D-200L : 20 pictures (High Quality mode)

80 pictures (Standard Quality mode)

Erase : One frame erase / All frames erase

Image pickup element

: 1/3 inch CCD solid-state image pickup

D-300L : 810,000-pixel

D-200L : 350,000-pixel

Recording image

D-300L : 1024 x 768 pixels
(High Quality mode)

D-200L : 640 x 480 pixels
(High Quality mode)

Auto white balance

: Full auto TTL

Lens : Olympus lens 5 mm, F2.8, 5 elements in 4 groups
(equivalent to 36-mm lens on 35-mm camera)

Aperture : F2.8, F5.6, F11

Photometric system

: TTL Center weighted average metering system

Exposure control : Program auto exposure

Working range

D-300L : 0.2 m ~ 0.5 m (0.65 ~ 1.64 ft.) (Macro mode)
0.5 m ~ ∞ (1.64 ft. ~ ∞) (Normal mode)

D-200L : 0.2 m ~ 0.75 m (0.65 ~ 2.46 ft.) (Macro mode)
0.75 m ~ ∞ (2.46 ft. ~ ∞) (Normal mode)

Shutter

D-300L : 1/8 ~ 1/500 sec. (used with mechanical shutter)

D-200L : 1/8 ~ 1/500 sec.

Exposure

D-300L : Equivalent to ISO 100

D-200L : Equivalent to ISO 130

Viewfinder

: Optical real image viewfinder (Parallax correction mark, backlight correction mark), LCD monitor

LCD monitor

: 1.8 inches TFT color LCD display

No. of pixels

: Approx. 61,000 pixel

On-screen display

: Date and time, frame number, protect mark, resolution modes, one/all erase mark, battery remaining warning

Battery charging time for flash

: approx. 6 sec. (at normal temperature with new battery)

Flash working range

D-300L : 0.2 m ~ 2.4 m (0.65 ~ 7.9 ft.)

D-200L : 0.2 m ~ 3.5 m (0.65 ~ 11.5 ft.)

Flash modes

: Auto-Flash (automatic flash activation in low light and backlight), Red-Eye Reducing Flash, Off (no flash), Fill-in Flash (forced activation)

Control panel

: Indicates resolution modes, number of pictures remaining, erase modes, flash modes, Selftimer, Battery remaining time, Macro mode and writing.

Autofocus (only with D-300L)

: TTL system autofocus

Detection method

: Contrast detection system/Focusing range;
0.2 m ~ ∞ (0.65 ft. ~ ∞)

Selftimer

: Electronic selftimer with 12-sec. delay

Outer connector

: DC input terminal, Data input/output terminal (RS232C)

Date and time

: Record with picture data simultaneously

Automatic calendar system

: Up to 2023.

Power supply for automatic calendar system

: 3 V lithium battery (CR2025) x 1 (changeable)

Operating environment

temperature : 0 ~ 40°C / 32 ~ 104°F (operation)
-20 ~ 60°C / -4 ~ 140°F (storage)

humidity : 30 ~ 90 % (operation)
10 ~ 90 % (storage)

Power supply

: Four AA alkaline batteries (AA NiCd battery, AA lithium battery, AA nickel hydride battery can also be used but the battery check function won't work correctly. AA manganese batteries cannot be used.)

Dimensions

: 145 (W) x 72 (H) x 47 (D) mm
(5.7 x 2.8 x 1.8 inches)

Weight

D-300L : 310 g (11.9 oz) (without batteries)
D-200L : 295 g (10.4 oz) (without batteries)

SPECIFICATIONS ARE SUBJECT TO CHANGE WITHOUT ANY NOTICE OR OBLIGATION ON THE PART OF THE MANUFACTURER.

OLYMPUS®

OLYMPUS OPTICAL CO., LTD.

San-Ei Building, 22-2, Nishi Shinjuku 1-chome, Shinjuku-ku, Tokyo, Japan. Tel. 03-3340-2026

OLYMPUS AMERICA INC.

Two Corporate Center Drive, Melville, NY 11747-3157, U.S.A. Tel. 516-844-5000

OLYMPUS OPTICAL CO. (EUROPA) GMBH.

(Premises/Goods delivery) Wendenstraße 14-16, 20097 Hamburg, Germany. Tel. 040-237730

(Letters) Postfach 10 49 08, 20034 Hamburg, Germany.

OLYMPUS OPTICAL CO. (U.K.) LTD.

2-8 Honduras Street, London EC1Y 0TX, United Kingdom, Tel 0171-253-2772