

DAEWOO

Service Manual

FLOOR STANDING AIR CONDITIONER

Model: DPB-280LH



**DAEWOO ELECTRONICS CO., LTD.
OVERSEAS SERVICE DEPT.**





Contents

CONTENTS

1. Installation Guide.....	2
2. Specification.....	5
3. Outline.....	6
4. Operation.....	8
5. Circuit Diagram.....	18
6. Refrigerant Cycle.....	35
7. Trouble Shooting.....	36
8. Exploded Diagram.....	43

1. INSTALLATION GUIDE

1 INSTALLATION PLACE

◆Indoor unit

- Flat and strong place in the room
- No obstacles in front of air in/out grille
- Easy place to connect drain hose to outside of room
- Easy place to connect copper tube with outdoor unit
- Secure enough distance from neighboring objects as shown below.
- Secure enough distance from neighboring objects as shown below.

◆Outdoor unit

- A place no reach of direct ray of sun (if necessary, shield the light)
- No obstacles in front of air in/out grille
- A place having a drain out-let
- Easy place to connect copper tube with indoor unit
- Secure enough distance from neighboring objects as shown below.

⚠ **CAUTION** : Do not hang the outdoor unit on the wall of building, in case of falling, it may cause a serious trouble and damage.

2 SPACE TO INSTALL

Secure enough space from the neighboring objects as shown below.
This is required to operate the unit efficiently.

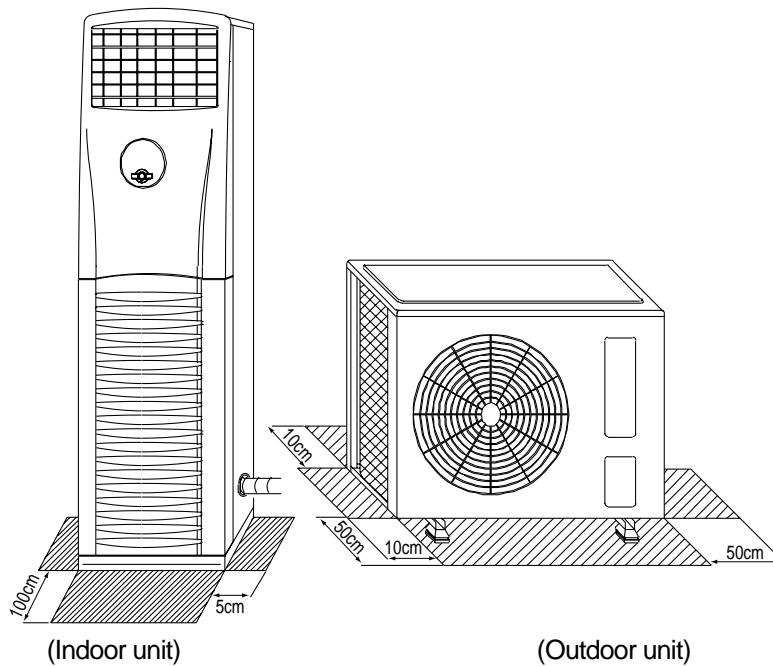

◆ Specification and method of copper tube

- Connection method of copper tube is to make connection with flare nut at the end of the copper tube with a flare tool.

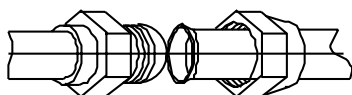
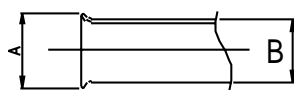

Flare specification		Unit: mm	
Nominal diameter		A	B
Liquid	3/8"	12~12.4	9.52
Gas	5/8"	18.6~19	15.88

Torque		Unit: mm	
		Torque	
Liquid	3/8"	300Kg • cm	
Gas	5/8"	500Kg • cm	

3 INSTALLATION OF INDOOR UNIT

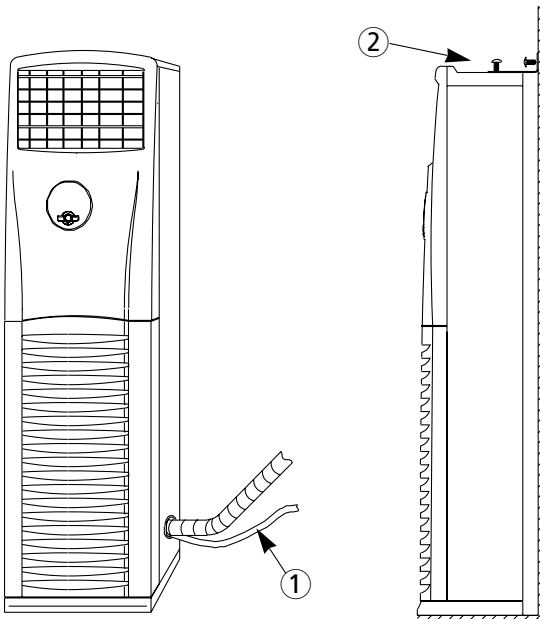

- 1) Drain hose should maintain downward slope to outside of room.
- 2) Indoor unit should be fixed firmly with the bracket to avoid falling down. The bracket has several holes to fix the unit any direction needed (fore/back/right/left)

4 INSTALLATION OF OUTDOOR UNIT

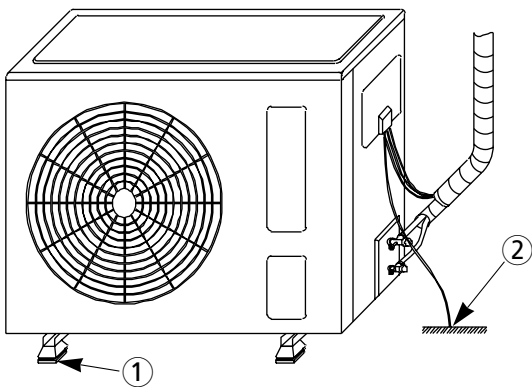

- 1) Cushion rubbers absorb vibration of outdoor unit
- 2) The unit must be grounded for safety in accordance with local electrical codes. (Grounding resistance should be under 100 ohms)

5 REFRIGERANT TUBE CONNECTION

CAUTION

- Use designated diameter and thickness of tube.
- Connect all tube as short as possible and fix firmly.
- Less than 3M of the difference of height between indoor and outdoor unit is desirable.
- Fill up more refrigerant if the connection tube is longer than 5M (50g/M).
(The refrigerant volume filled from the factory is suitable for 5M connection)
- Be careful not to let in any dust or motes into the tube when the tube passes the wall.
- When insulating the connection, use foam rubber or equivalent.

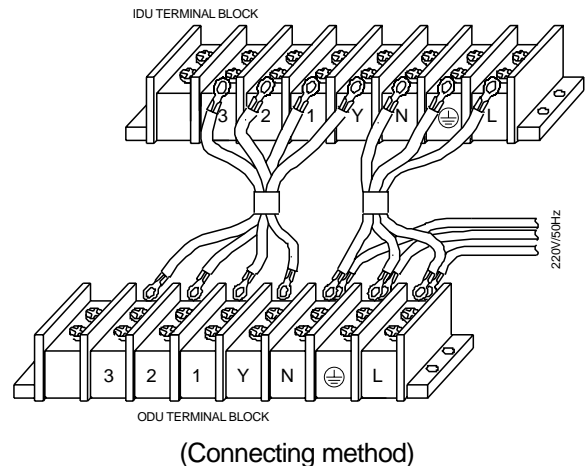

	Spec	Color	
3	1.25mm ²	BLUE	SIGNAL LINE
2	1.25mm ²	BLACK	SIGNAL LINE
1	1.25mm ²	RED	SIGNAL LINE
Y	1.25mm ²	BROWN	SIGNAL LINE
N	1.25mm ²	BROWN	MAIN POWER (INDOOR)
⊕	1.25mm ²	YEL/GRN	MAIN POWER (INDOOR)
L	1.25mm ²	RED(or BLUE)	MAIN POWER (INDOOR)
N	2.0mm ²	BLACK	MAIN POWER (OUTDOOR)
⊕	2.0mm ²	YEL/GRN	MAIN POWER (OUTDOOR)
L	2.0mm ²	WHITE	MAIN POWER (OUTDOOR)

(Specification of harness)

6 ELECTRICAL WIRING

⚠ CAUTION

- Be sure to use designated wires and make it as short as possible
- Use an exclusive power supply for the air conditioner
- Use an electricity leakage interrupter having suitable capacity.
- Grounding resistance should be under 100 ohms and the grounding wire should be connected firmly to the terminal of out door unit.

■ Wire connection of indoor and outdoor unit

- When connecting wires of indoor and outdoor unit, the numbers of terminal block and terminals of connecting wires should match exactly as shown below.
- Terminals of connecting wires should be fixed firmly using wire fixing tool to the same direction of terminal board.

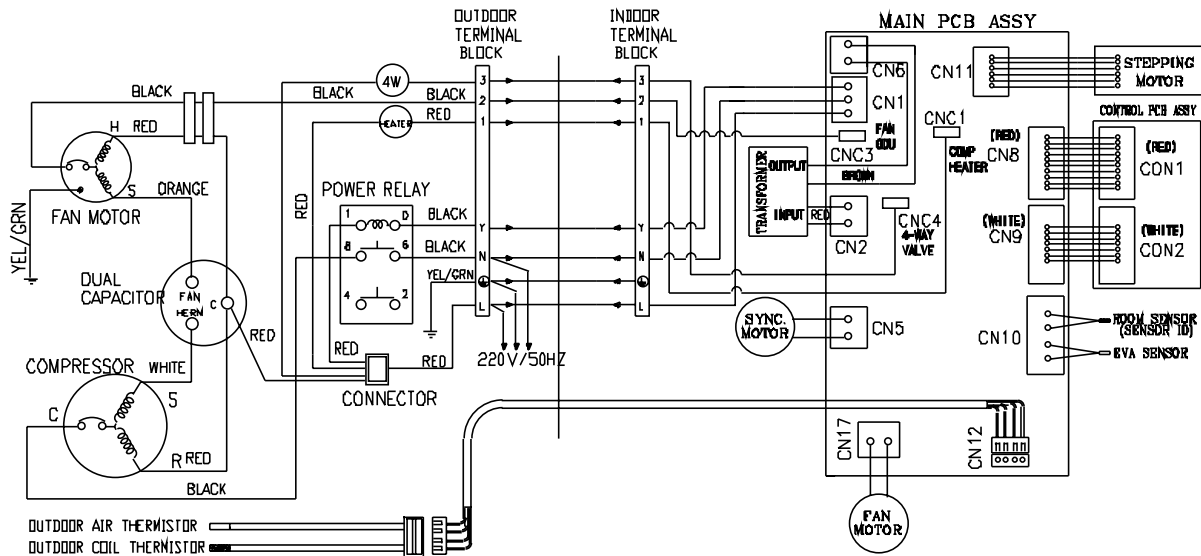

(Diagram of wire connection)

2. SPECIFICATIONS

◆DPB-280LH

ITEM		MODEL	DPB-280LH	
Function			COOLING	HEATING
Class			T	
Power			220~240V/ 50Hz	
Capacity	W		8,200	8,200
	Btu/h		28,000	28,000
Dehumidification		l/h	-	-
Electrical Data	Running Current	A	14	14
	Power Input	W	2,800	2,800
	Starting Current	A	-	
Compressor	Type		Scroll	
	Model		ZR36K3-PFJ-501	
	Capacitor		50 μ F/370V AC	
Fan			Indoor Unit	Outdoor Unit
	Type		Sirocco	Propeller fan
	Capacitor		5 μ F/400V AC	8 μ F/370V AC
	Motor Model Number		DE112	A2935BA010
Refrigerant (R-22)	Control		Capillary	
	Charge Q'ty	g	2,000	
Connection	Type		Flare	
	OD (Liquid/Suction)	in(mm)	3/8" (9.52mm)	5/8" (15.88mm)
Dimensions (W x H x D)		mm	500 x 1,830 x 350	872 x 675 x 325
Net Weight		kg	40	66

3. OUTLINE

1 INDOOR UNIT

◆DPB-280LH

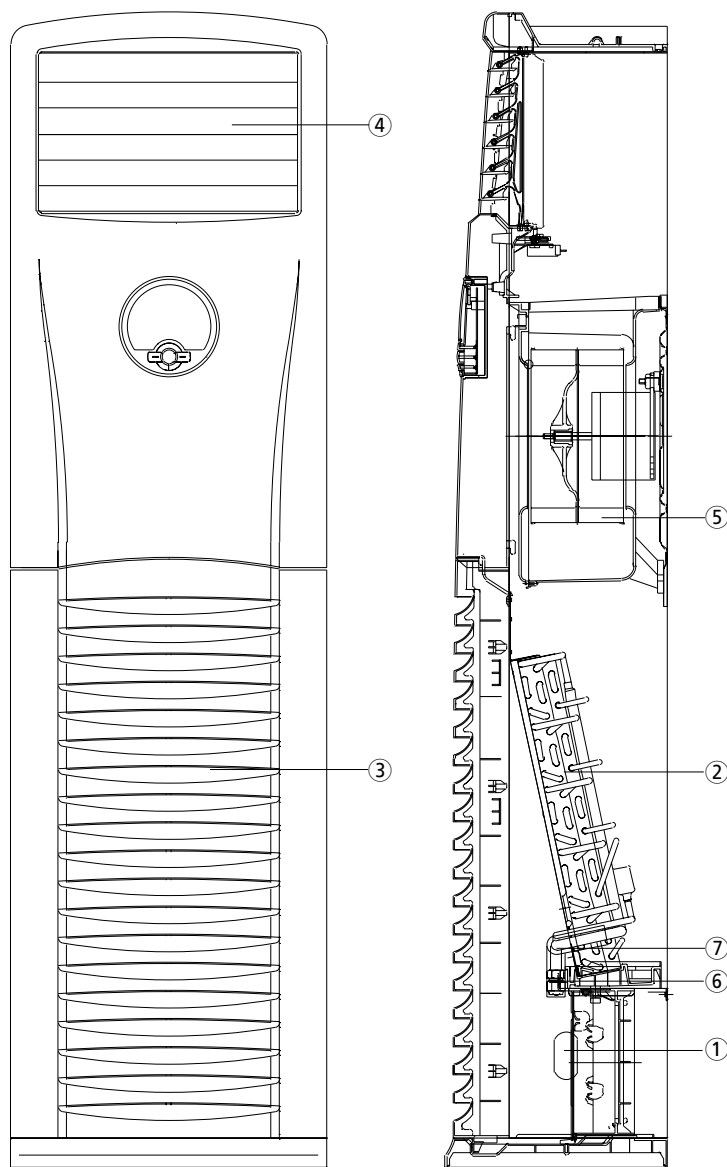

No	Part Name	Quantity	Description	Remarks
1	Connecting Hole	3	ø60X100 (Left, Right, Back)	
2	Evaporator	1	Heat Exchanger	
3	Suction Grille	1	Air Inlet	
4	Discharge Grille	1	Air outlet	
5	Fan Blower	1	Sirocco Type	
6	Joint (Gas)	1	OD ø15.88mm	
7	Joint (Liquid)	1	OD ø9.52mm	

2 OUTDOOR UNIT

◆DPB-280LH

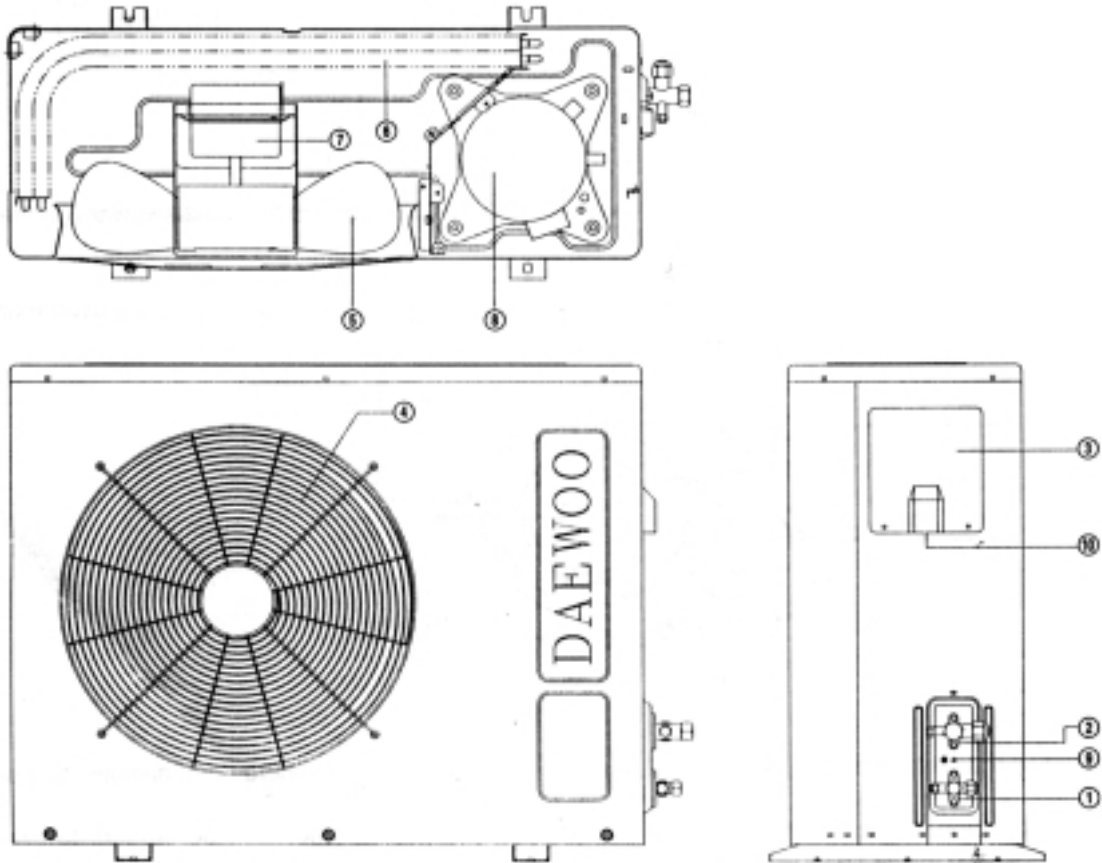

No	Part Name	Quantity	Description	Remarks
1	Service Valve (Liquid)	1	OD ø9.52mm Flare Type	
2	Service Valve (Gas)	1	OD ø15.88mm Flare Type	
3	Service Door	1		
4	Fan Guard	1	Fan Protector	
5	Fan Blower	1	Propeller type	
6	Condenser	1	Heat Exchanger	
7	Fan motor	1	Four propeller fan	
8	Compressor	1	Depend on Models	
9	Earth Bolt	1	Ground	
10	Connection Hole	1	Power & Control wire	

4. OPERATION

1 PARTS OF NAME AND FUNCTION

Indoor Unit

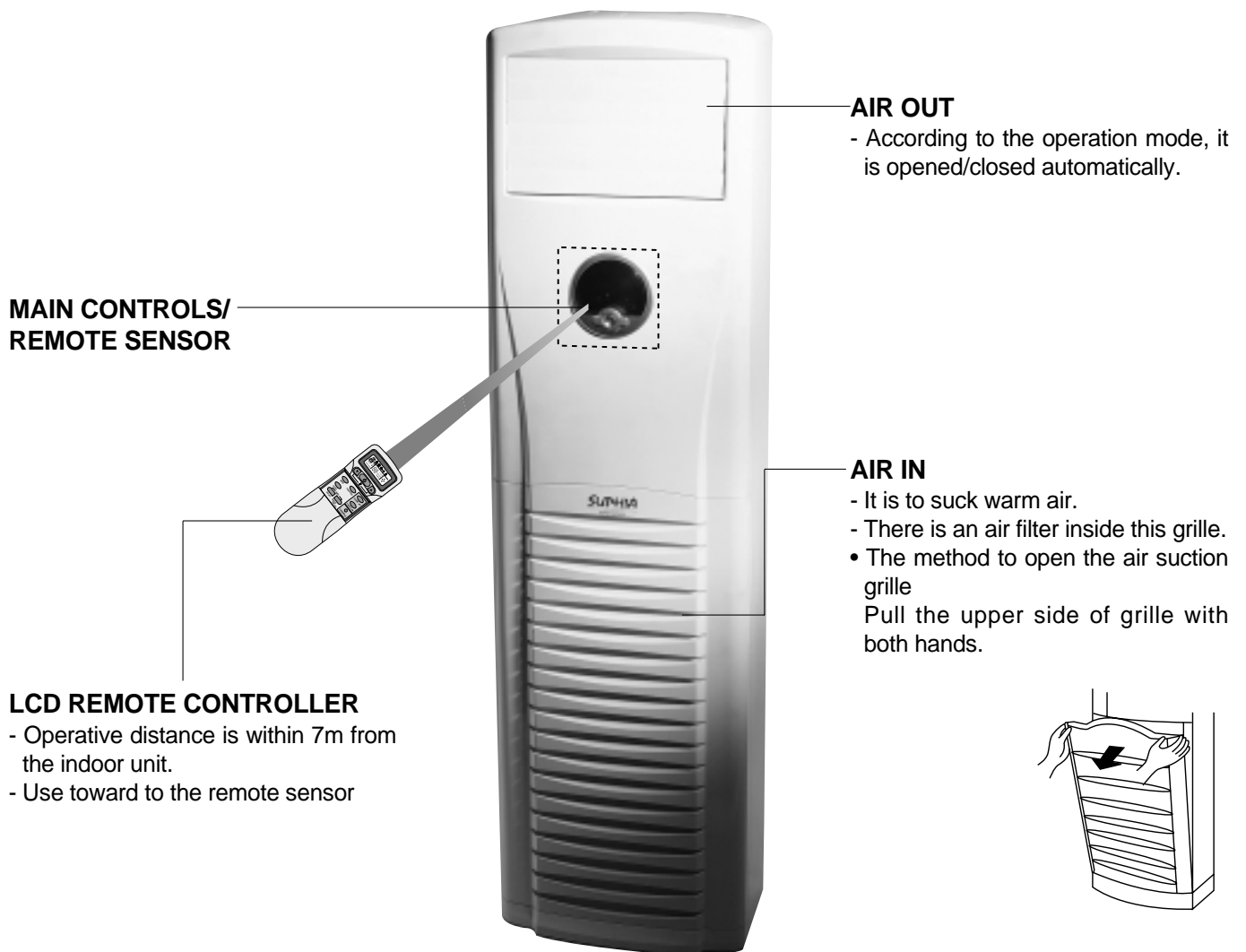

ROOM TEMPERATURE / DESIRED TEMPERATURE INDICATOR

- It displays current room temperature and desired room temperature.

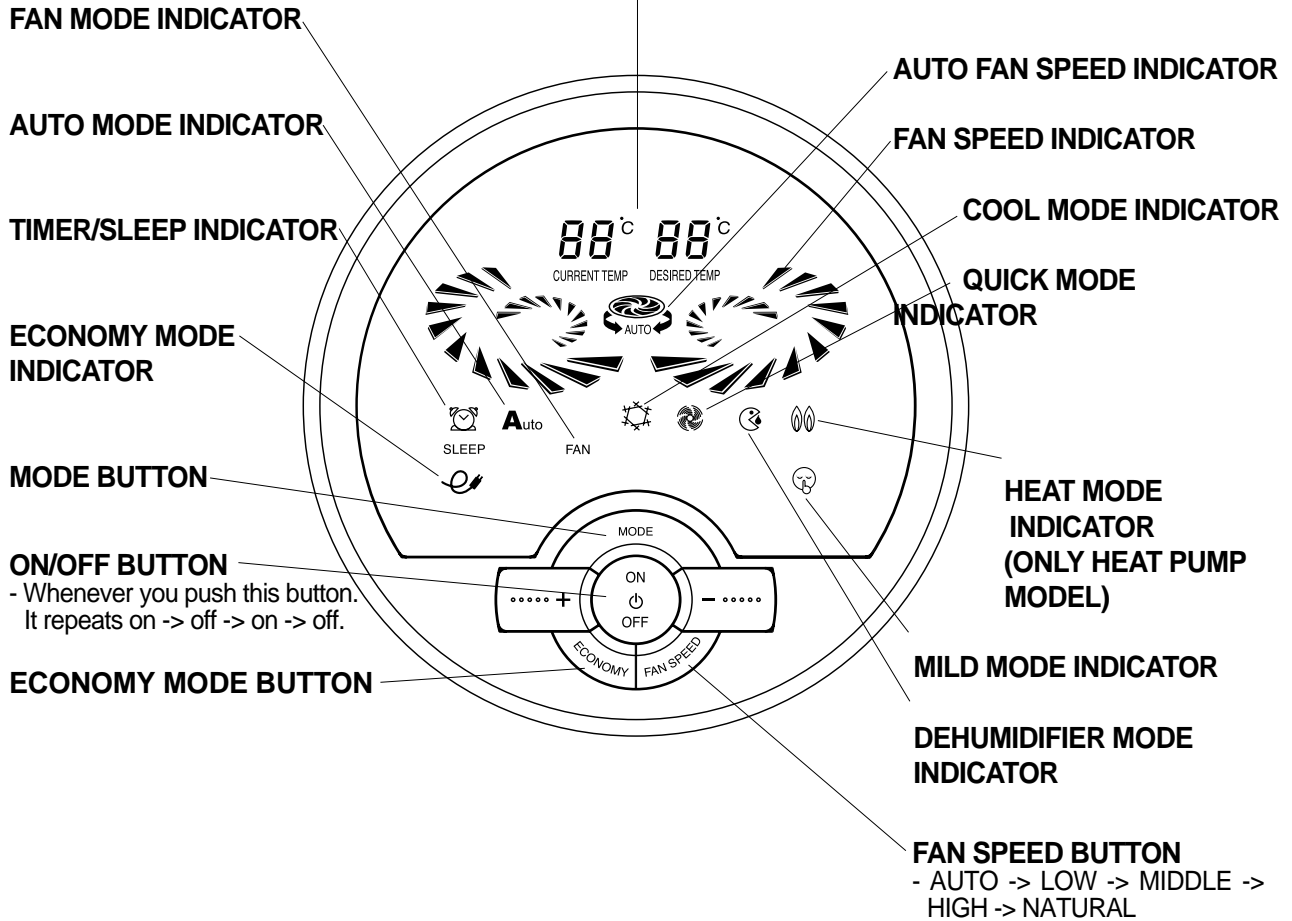

TEMPERATURE BUTTONS

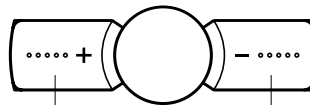

- Each time you push this button, temperature goes up by 1°C.

- Each time you push this button, temperature falls by 1°C.

Outdoor Unit

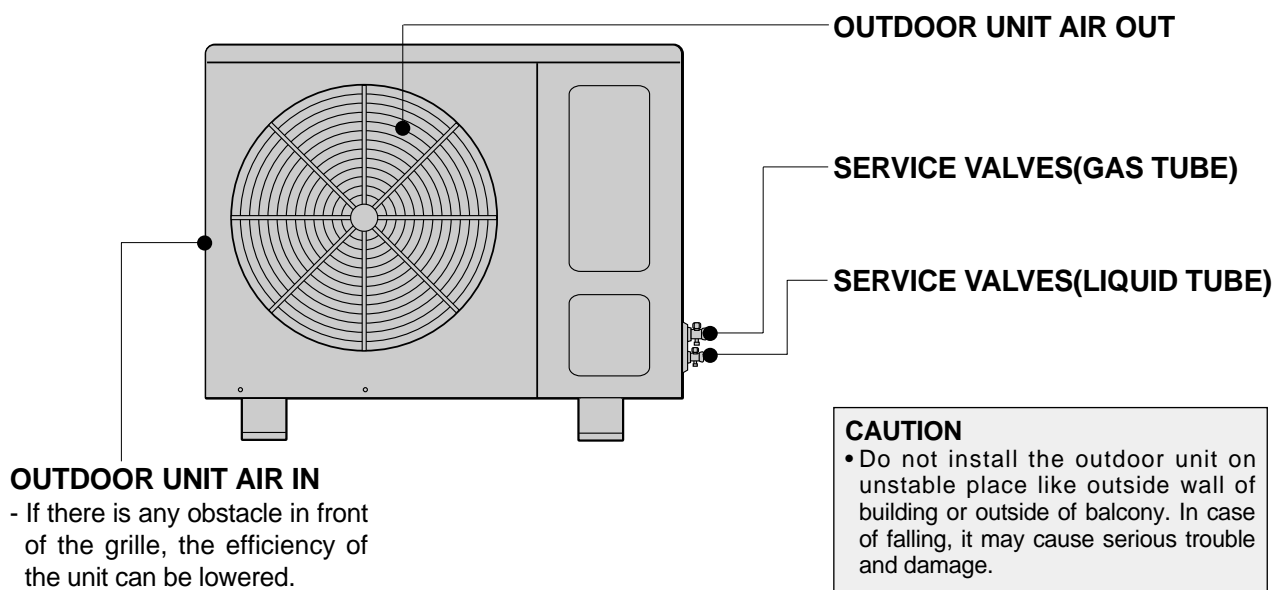

2 REMOTE CONTROLLER

Name of Each Button

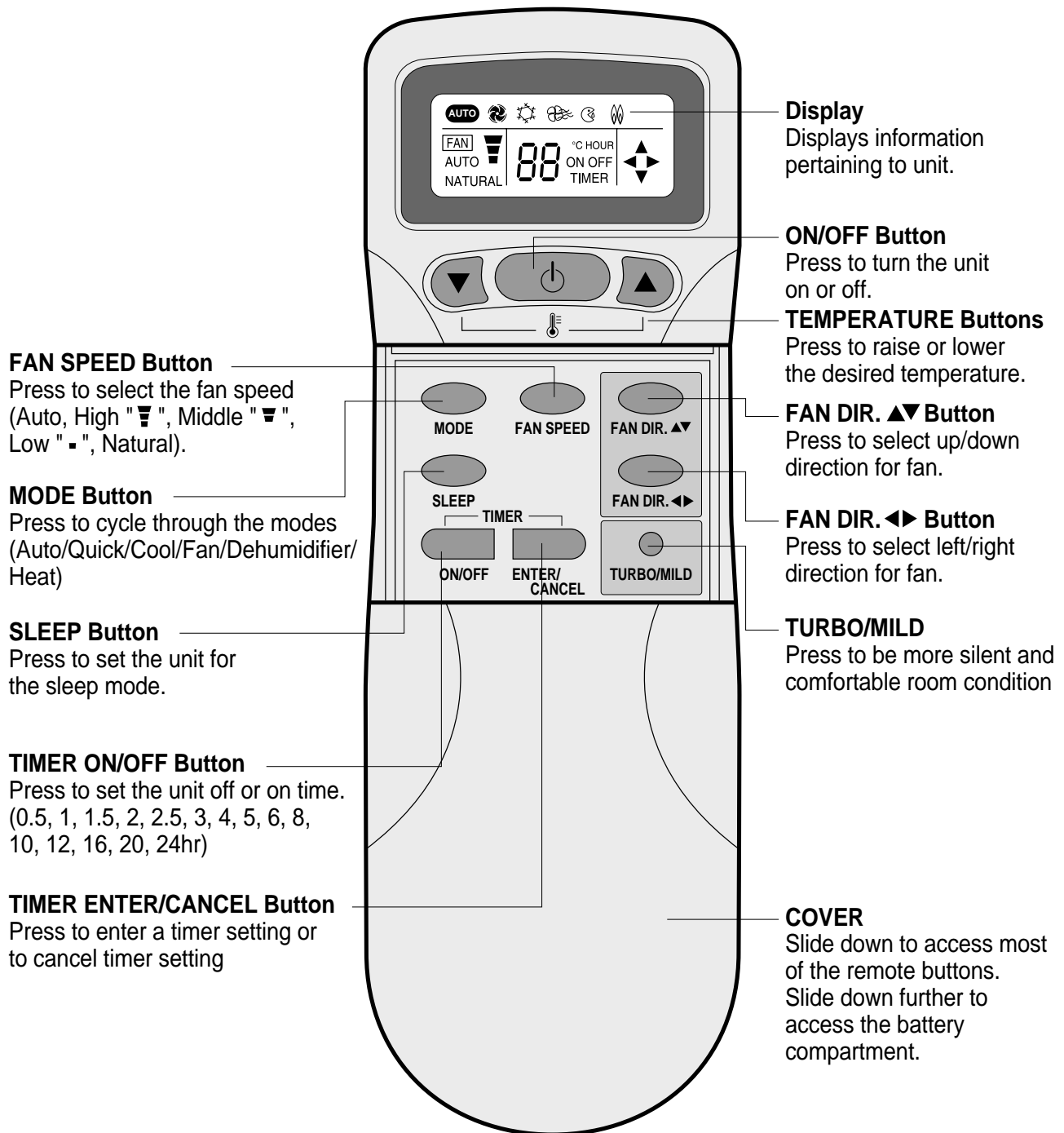

3 REMOTE CONTROLLER DISPLAY

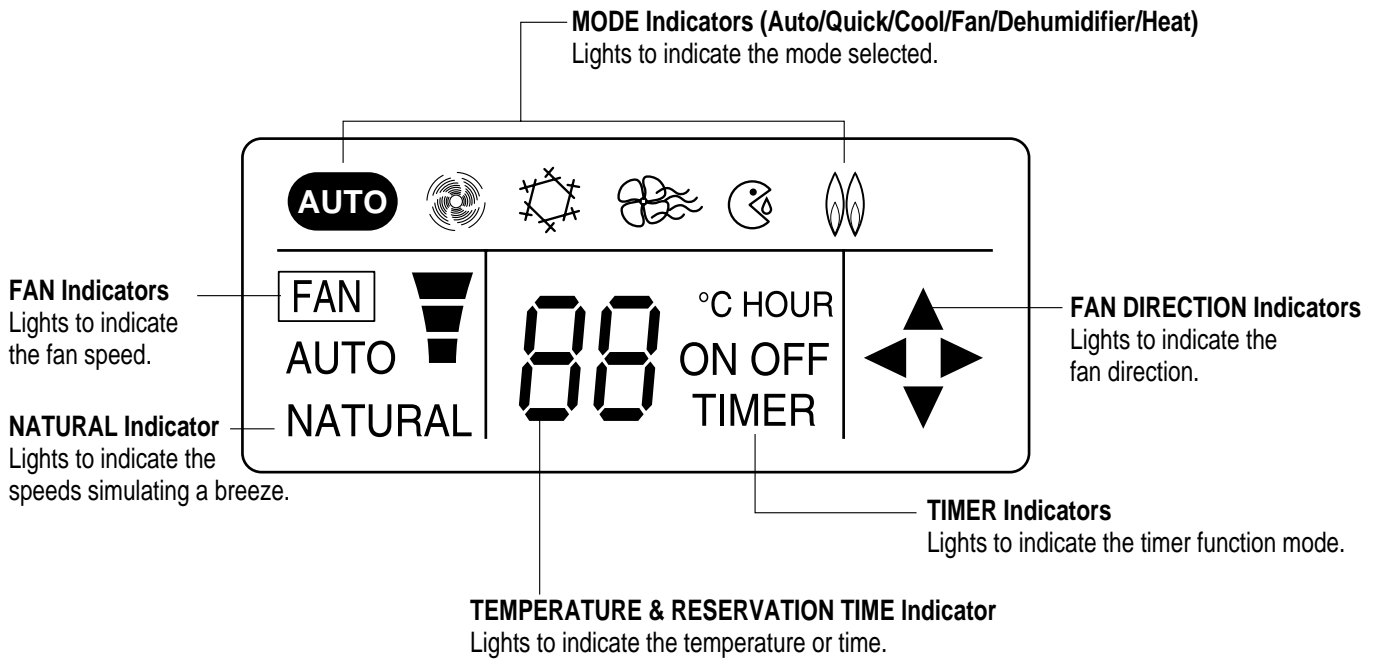

Replacing Batteries

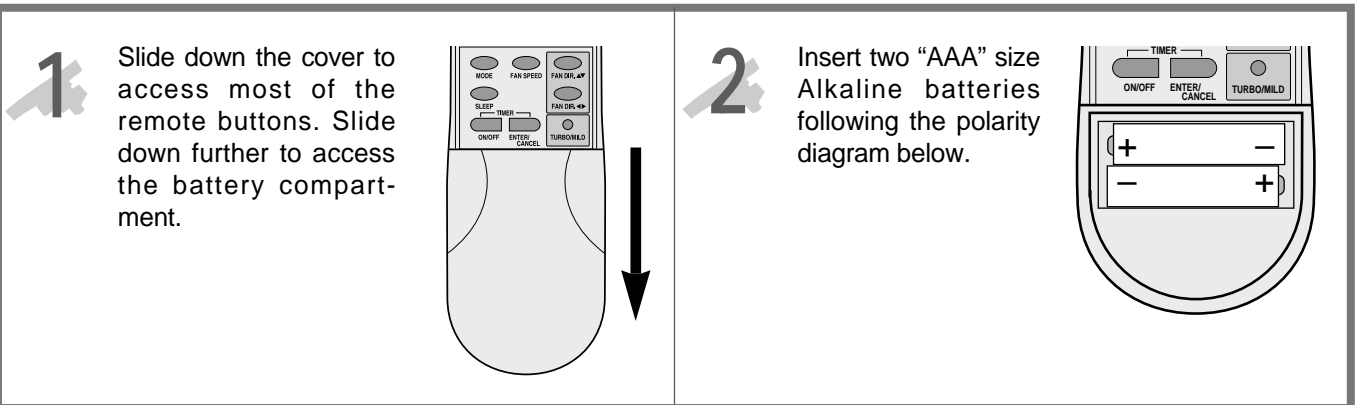

4 DESCRIPTION OF FUNCTIONS

OFF-Timer

If you set time in OFF-Timer Mode, the unit will stop at the set time.

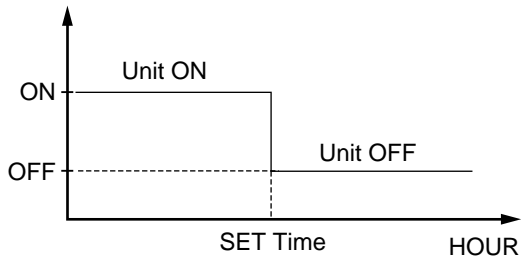

ON-Timer

If you set time in ON-Timer Mode, the unit will run at the set time.

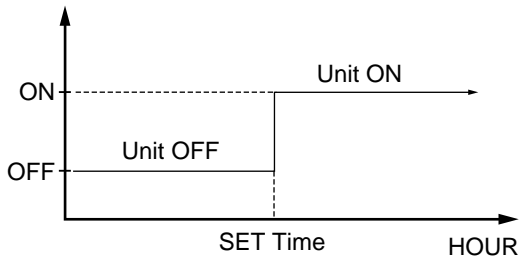

Control of Room Temperature

- (1) Range of setting temperature: 18~32°C
- (2) Setting temperature: Operating temperature of compressor

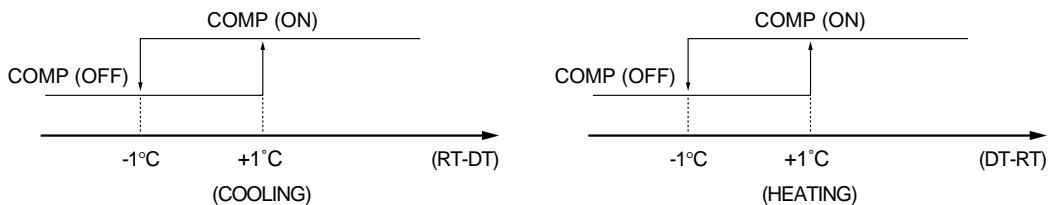

*RT: ROOM TEMPERATURE
DT: DESIRED TEMPERATURE

- (3) During the time of test operating, Fan (Indoor, Outdoor) and Compressor is running regardless of room temperature.

Buzzer

If the Indoor Unit Display receive the signal of Remote Controller, you can hear the signal "beep –" or "beep, beep".

- (1) In the case of receiving ON/OFF signal-"beep" "beep"
- (2) And so on-"beep"

Fan Speed (Indoor Unit)

- (1) Motor speed (high speed, middle speed, low speed).
- (2) Remote controller setting fan speed. (Auto, L, M, H, Natural)
- (3) Relation of operating mode between fan speed. (legned: X-no relation)

	FAN ONLY	COOL	DEHUMI-DIFICATION	AUTO	QUICK	HEAT
H	H	H	L	H	H	H
M	M	M	L	M	H	M
L	L	L	L	L	H	L
Auto	X	Auto	L	Auto	H	Auto
Natural	Natural	Natural	L	Natural	H	Natural

(4) Automatic Operation

If the unit is set in 'AUTO' mode, the unit operates automatically according to the room temperature to keep the room temperature comfortable.

(COOLING)

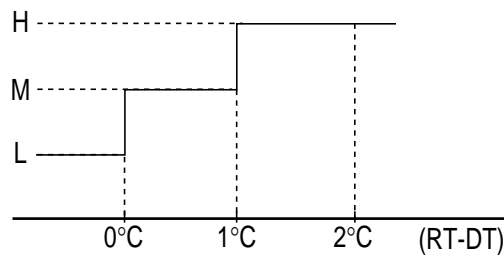

(HEATING)

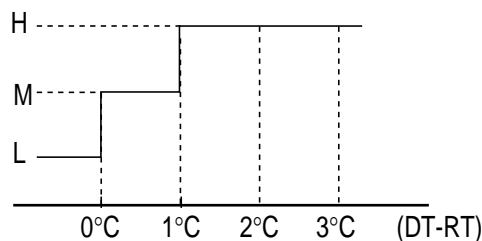

Sleep Mode

- (1) When you are going to sleep, select sleep switch and the unit controls the room to the desired temperature.
(The unit will not operate after 4 hour)
- (2) For changing the temperature.

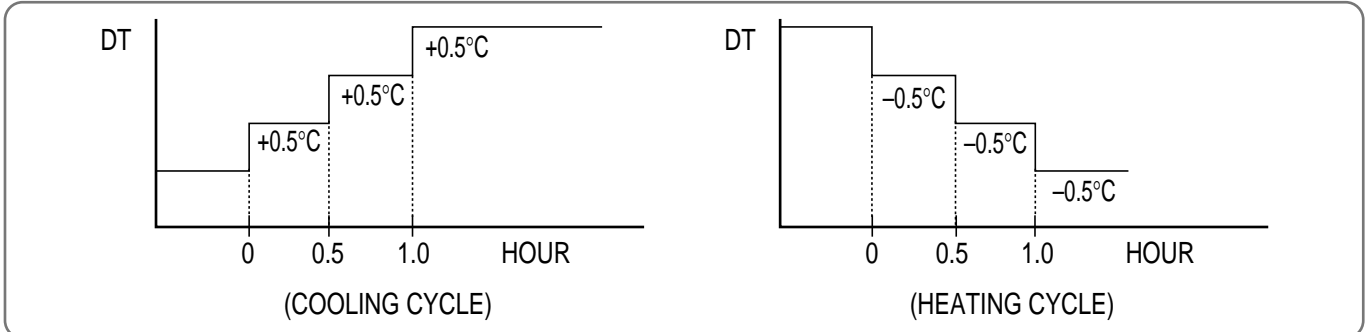

- (3) To cancel sleep mode, press the SLEEP button again or press the MODE button once.: the SLEEP indicator will disappear in the display.

Frost Prevention of Indoor Unit

When the unit operates at low ambient temperature, frost may appear on the Evaporator. When the indoor coil temperature is lower than -2°C at the end of 10 minutes of continuous compressor operation from the start, the microcomputer of the unit stops the compressor to protect the unit from the frost. The control procedure for indoor coil freeze protection.

- 1) The compressor and outdoor fan turn off.
- 2) Indoor fan operates according to user set speed.
- 3) The normal operation returns when the indoor coil temperature is higher than 7°C or equal to 7°C .

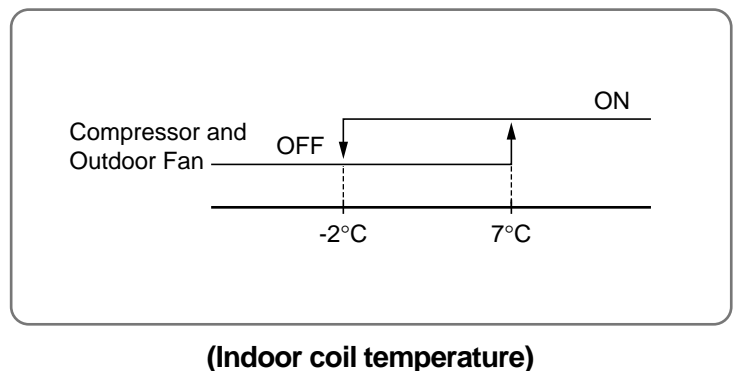

3 min. Time Delay of Compressor

In normal operation, there is a time delay of three minutes between turn off and turning back on including initial

3 Seconds Time Delay of Indoor Fan Motor

When the speed of indoor fan motor changes, there is a time delay of 3 seconds at each speed step.

Auto Mode

(1) In Auto Mode

After the indoor fan is operated for 20 seconds in the Auto Mode, the unit will operate automatically by selecting operating Mode according to the room temperature

(RT: Room temperature)
(DT: Desired)

ROOM TEMPERATURE	OPERATING MODE
$DT+3^{\circ}\text{C} < RT$	Cooling
$DT-2^{\circ}\text{C} \leq RT \leq DT+2^{\circ}\text{C}$	Dehumidifier
$DT -2^{\circ}\text{C} > RT$	Heating

(2) Selecting Operating Mode Again

Room temperature meets desired temperature and the compressor stops running over 30 minutes, then the unit selects operating Mode again.

Dehumidification Mode

- ① $DT+1^{\circ}\text{C} < RT$
Outdoor Fan, Compressor : ON
Indoor Fan : Low speed
- ② $DT-1^{\circ}\text{C} \leq RT \leq DT+1^{\circ}\text{C}$
Outdoor Fan, Compressor : 3 min/ON, 5 min/OFF
Indoor Fan : Low speed
- ③ $DT-1^{\circ}\text{C} > RT$
Outdoor Fan, Compressor : OFF
Indoor Fan : Low speed

Air Discharge Direction

1. Press fan direction button to select fan direction
 - Press desired fan direction button, "UP • DOWN" or "LEFT • RIGHT" control louver moves, press again to stop

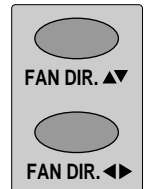

Quick Mode(Powerful Cooling & Heating)

(1) Cooling Mode

* When the room temperature is higher than 22°C or equal to 22°C

- ① Fan Speed: high speed (Fixed)
- ② Air discharge direction: The control is available.
- ③ Set temperature: 18°C (Fixed)

(1) Heating Mode

* When the room temperature is lower than 22°C

- ① Fan Speed: high speed (Fixed)
- ② Air discharge direction: The control is available.
- ③ Set temperature: 32°C (Fixed)

Self-Diagnostic Function

The control will contain diagnostic test to verify the integrity of the system.

(1) Error Code Display : RT (Room Temperature) LED

ERROR CODE	DISPLAY	ERROR CONTENTS
1	"E2"	Indoor unit sensor open or short
2	"E2"	Outdoor unit sensor open or short
3	" E3 "	Compressor, Electrical parts of comp. Gas leak

5. CIRCUIT DIAGRAM

1 WIRE CONNECTION OF INDOOR AND OUTDOOR UNIT

◆ DPB-280LH

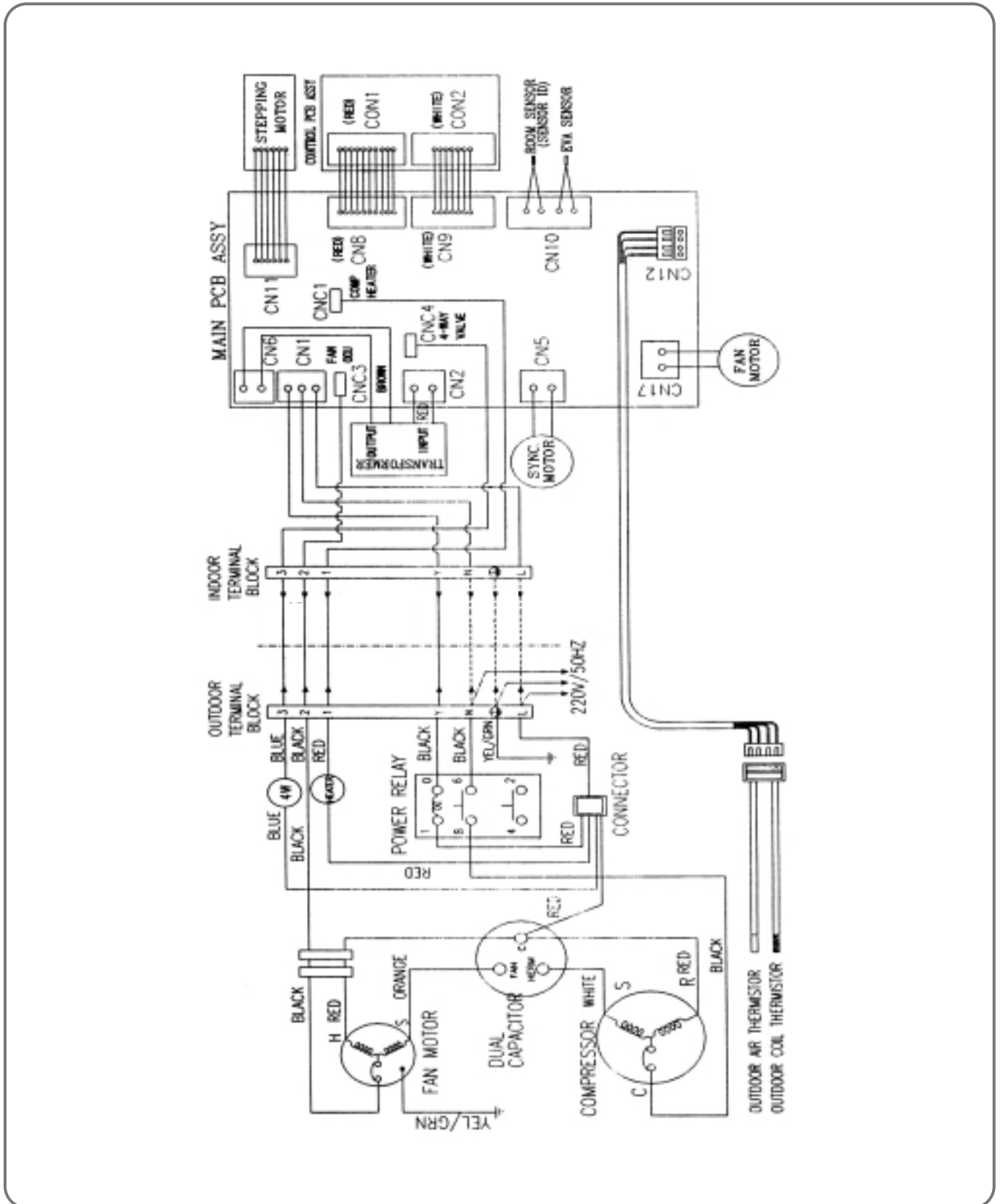

2 MAIN ELECTRIC PARTS

◆ DPB-280LH

Object/part No.	Manufacturer/trademark	Type/model	Technical data	Standard	Mark(s) of conformity
Motor-compressor	Copeland	ZR36K3-PFJ	AC220-240V 50Hz R22		DEMKO
Outdoor fan motor	DMI	A2935BA010	AC 230V 50Hz		NONE
Indoor fan motor	O-YANG	DE112	AC 230V 50Hz		NONE
Thermal protector for fan motor	Korea Taxas Instruments	17AM035A5	AC 250V		
Synchronous motor	Jaeil engineering	ST-16	AC 220-240V 50/60Hz		VDE
	Namyang Precision (Alter)	NYM-16H-1	AC 220-240V 50/60Hz		NONE
Stepping motor	Hyup jin precision	MSFCC20F02	DC 12V		NONE
Dual capacitor for compressor and outdoor fan motor	Samwha capacitor	37H08500B	8/50 μ F 370VAC		TUV, UL, CSA
Running capacitor for indoor fan motor	Samwha capacitor	PEB-958	5 μ F 400VAC		TUV, UL, CSA
Terminal block	Donglim	DTB-8P	AC 300V 25A		NONE
Transformer	Namsung electronics	DWA-5401FN	AC 220V/18VDC 50/60Hz		NEMKO
Reversing valve	Ranco japan	V26110D	AC 220-240V 50Hz		NONE
Compressor heater	Young chang		AC 220V 40W		NONE
AC Control realy	Omron electronics	G7L-2A-TUB	AC 220-240V 25A		VDE
Relay	Chung won electronics	CS11-12H	AC 250V 5A		TUV, UL, CSA
Fuse	Triad electronics	50T	AC 250V 3.15A		VDE
X2 capacitor	Pilkor electronics	PCX2 335	AC 275V		VDE, N.S.
Photocoupler	Toshiba electronics	TLP560J	AC 250V		VDE
Varistor	Marcon electronics	TNR15G561K	504-616V 50A		UL
Triac	Toshiba electronics	SM3JZ47	600V 3A		UL

3 PCB CIRCUIT DIAGRAM

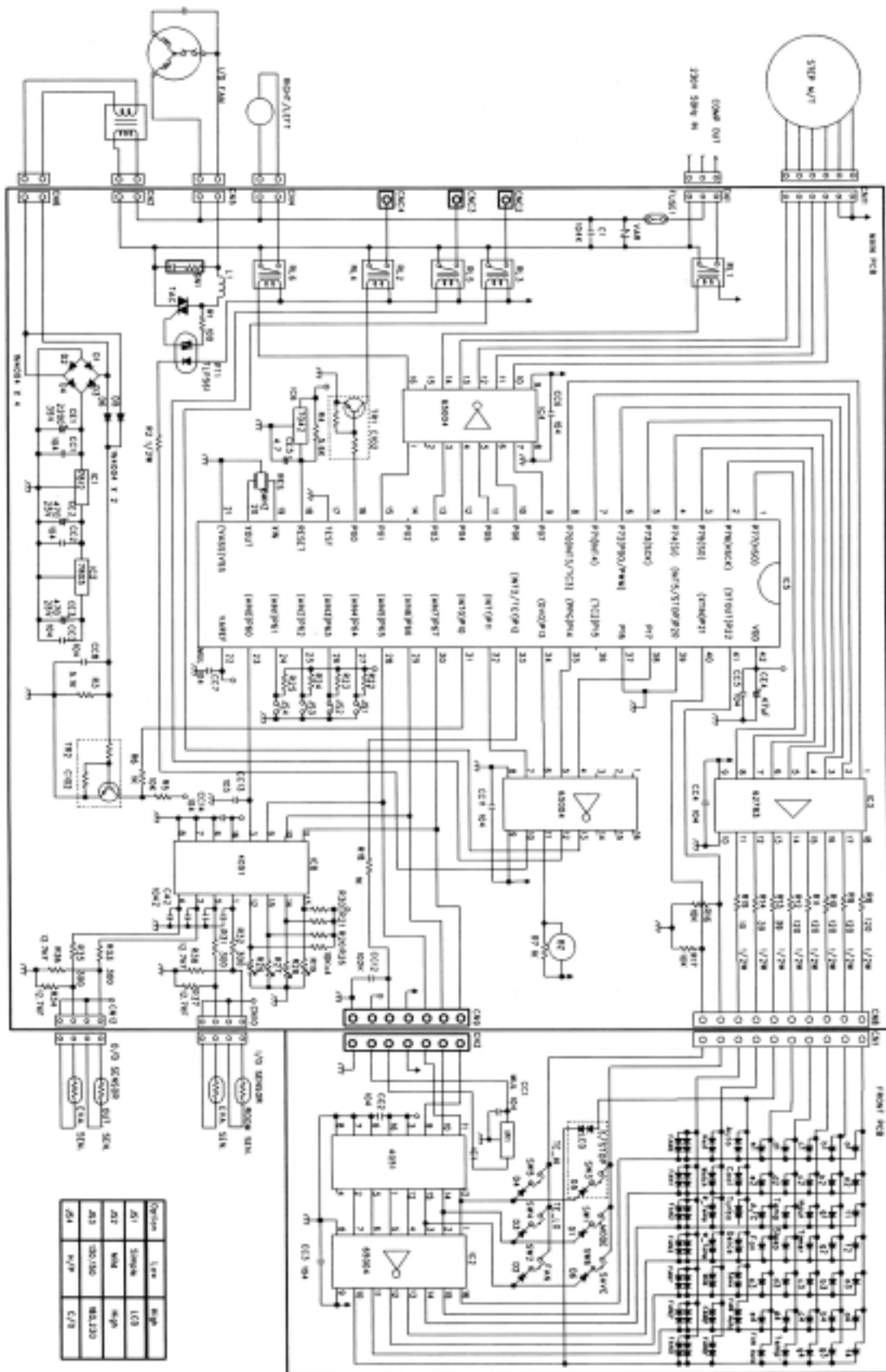

NO	Part Code	Part Name	Quantity	Specification
1	3108803400	PIN	3	GP881206-2(187)
2	5FVLB3152L	FUSE	1	250V 50T 3.15A
3	3107000600	FUSE CLIP	2	AFC-520
4	3108802500	WAFER	1	YW396-03AVD
5	3108802600	WAFER	1	YW396-03AVD (RD)
6	3108802700	WAFER	1	YW396-03AVD (BK)
7	3108802900	WAFER	1	YW396-05AVD
8	3108803000	WAFER	1	YW500-02V
9	3108801900	WAFER	1	SMW250-04
10	3108801910	WAFER	1	SMW250-04(RD)
11	3108802000	WAFER	1	SMW250-06
12	3108804100	WAFER	1	SMW250-07
13	3108802200	WAFER	1	SMW250-10 (RD)
14	D15G561K--	VARISTOR	1	15G561K
15	DZN4004A--	DIODE	6	1N4004 TAPE
16	CCXE1H102Z	C-CERA	1	102Z,50VDC
17	CCXE1H103M	C-CERA	1	103Z,50VDC
18	CCXE1E104M	C-CERA	8	104Z,25VDC
19	CDXE1H104M	C-MULTI	1	104Z,CR0561B-Z5U
20	CEXE35338M	C-ELEC	1	3300uF 35V SD
21	CEXE1V108C	C-ELEC	1	1000uF 35V SD
22	CEXE1E477C	C-ELEC	1	470uF 25V SD
23	CEXE1C106C	C-ELEC	1	10uF 50V SS
24	CEXE1C475C	C-ELEC	1	4.7uF 50V SS
25	CN4XD104M	CAPA. ARRAY	1	F4 104Z
26	RN-4K1272F	RESISTOR	2	1/4W-12.7KF
27	RD-4K103J-	RESISTOR	10	1/4W-10KJ
28	RD-4K842F-	RESISTOR	2	1/4W-8.4KF
29	RD-4K562J-	RESISTOR	2	1/4W-5.6KJ
30	RD-4K102J-	RESISTOR	3	1/4W-1KJ
31	RD-4K301J-	RESISTOR	4	1/4W-300J
32	RD-4K101J-	RESISTOR	1	1/4W-100J

NO	Part Code	Part Name	Quantity	Specification
33	RD-2K200J-	RESISTOR	1	1/2W-20J
34	RD-2K390J-	RESISTOR	2	1/2W-39J
35	RD-2K121J-	RESISTOR	5	1/2W-150J
36	RD-2K102J-	RESISTOR	1	1/2W-1KJ
37	CLV-B3104M	C-LINE ACROSS	1	275V 104K
38	4EFR-37071	SNUBBER	1	0.1UF 120 300V
39	3105796100	HEAT SHINK	1	33(H)X23X17
40	3106002900	WASHER	1	HEAT SINKøĀ
41	3105698200	BUZZER	1	DP-2520BA
42	52C131J003	COIL	1	130uH 3A
43	3109400100	JUMPER	32	10mm
44	3109400100	JUMPER OPTION	1	10mm
45	3104398700	PCB MAIN	1	162X169
46	5SC0101128	RELAY	5	CS11-SH12
47	1KA7812AP-	IC REGULATOR	1	KIA7812P
48	1KA7805AP-	IC REGULATOR	1	KIA7805P
49	TKRC102M--	TR	2	KRC102M
50	1KA7042P--	IC RESET	1	KIA7042P
51	4850103610	RESONATOR	1	CST8.00MGW
52	TSM3JZ47--	TRIAC	1	SM3JZ47
53	1TLP560J--	PHOTO COUPLER	1	TLP560J
54	13GS87PH46	IC MICOM	1	TMP87C846AN
55	13GT4051B-	IC MUX	1	TC4051BP
56	13GT62004A	IC DRIVE	2	TD62004AP
57	13GT62783A	IC DRIVE	1	TD62783AP

4 PCB DRIVING DESCRIPTION

Power Supply(1)

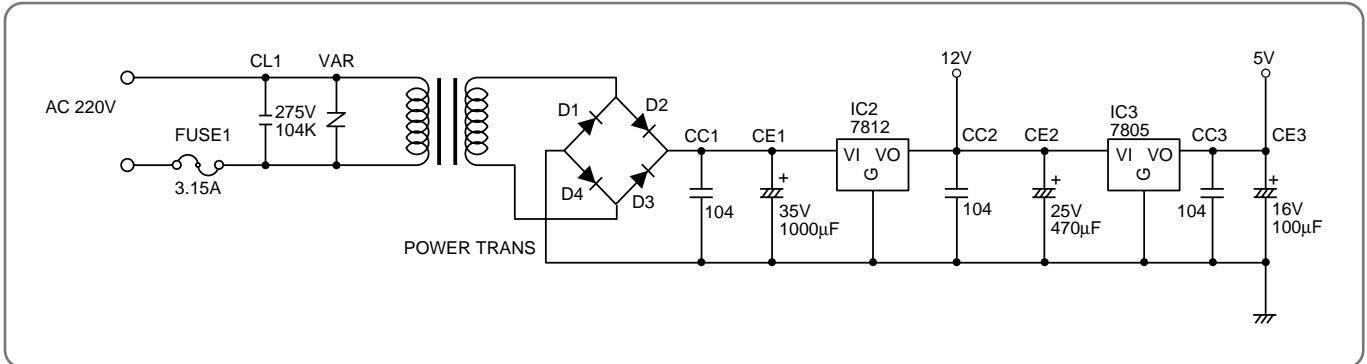

DESCRIPTION

DC Power Supply in circuit needs +12V and +5V. +12V is used for Compressor Driving Relay, Triac Driving Photo Triac, Buzzer Driving, Stepping Motor. AC voltage of secondary Power Transformer is rectified by Bridge Diode, and it is filtering by Main Condensor CE1.

Filtered DC voltage is about +18V, is regulated +12V DC by Regulator IC7812.

And it is regulated +5V DC by Regulator IC7805.

VAR is surge filter and CC1, CC2, CC3 is Noise filter.

Oscillator(2)

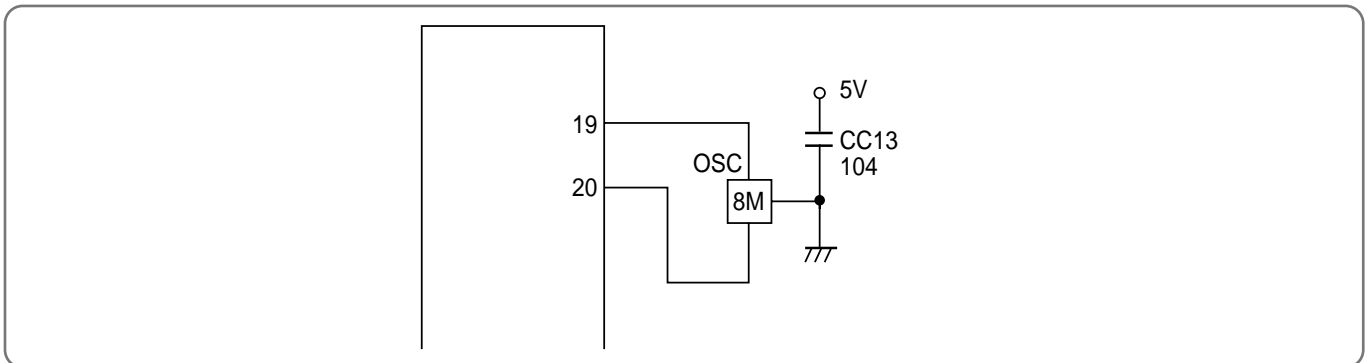

DESCRIPTION

Oscillatory Frequency drive Micom, it is made up 8MHz resonator oscillatory Frequency.

Ocillatory wave is as following Fig 2-1.

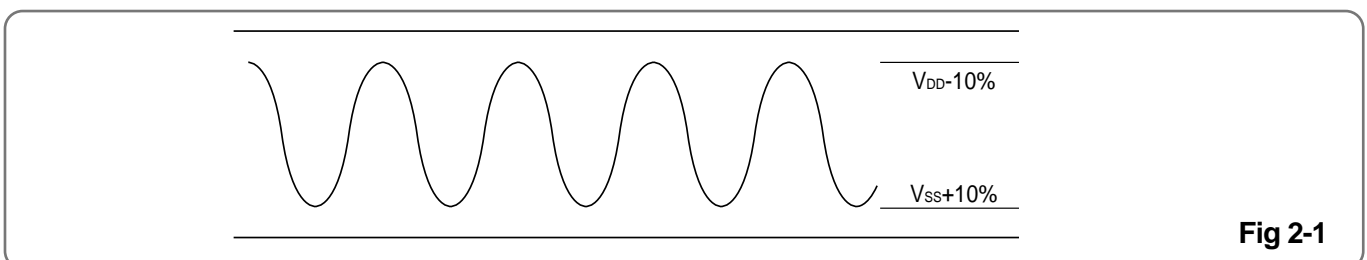

Sensor(3)

Room temperature and Evaporator temperature Sensor Input

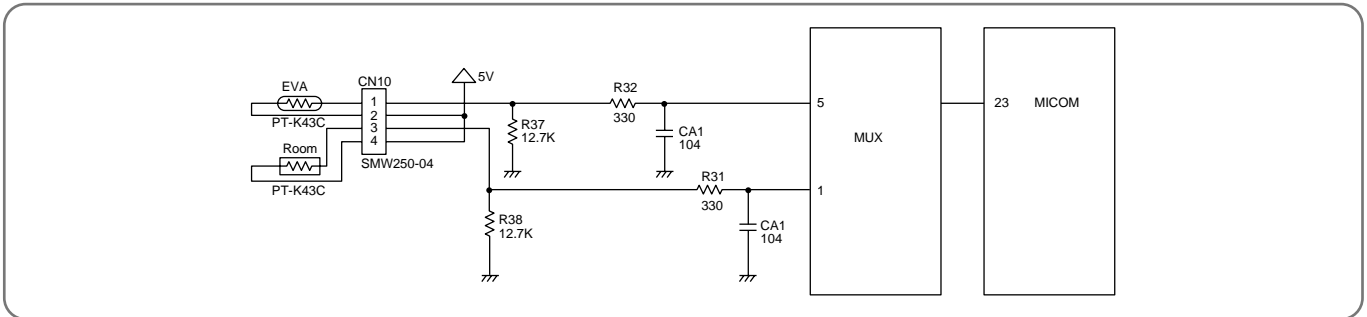

DESCRIPTION

Number 23 of Micom is Terminal of A/D convertor Input.

Room temperature and Evaporator temperature is sensing by change of Thermister Resistance, Micom is put in 5V by ratio between R37 (12.7K Ω) and R38 (12.7K Ω).

Relation between temperature and voltage is following Table 3-1.

CA1 is Noise filter.

Resistance & Voltage of the Sensor

temp($^{\circ}$ C)	resistance1(Ω)	Vout(V)	temp($^{\circ}$ C)	resistance1(Ω)	Vout(V)	temp($^{\circ}$ C)	resistance1(Ω)	Vout(V)
-10	54,769	0.941	17	14,288	2.353	44	4,526	3.686
-9	52,070	0.980	18	13,629	2.412	45	4,435	3.706
-8	49,579	1.020	19	13,002	2.471	46	4,255	3.745
-7	47,272	1.059	20	12,405	2.529	47	4,080	3.784
-6	44,116	1.118	21	12,021	2.569	48	3,908	3.824
-5	42,190	1.157	22	11,468	2.627	49	3,739	3.863
-4	40,390	1.196	23	10,939	2.686	50	3,656	3.882
-3	37,902	1.255	24	10,432	2.745	51	3,493	3.922
-2	36,368	1.294	25	9,947	2.804	52	3,332	3.961
-1	34,235	1.353	26	9,634	2.843	53	3,253	3.980
0	32,279	1.412	27	9,182	2.902	54	3,098	4.020
1	31,064	1.451	28	8,890	2.941	55	3,021	4.039
2	29,358	1.510	29	8,467	3.000	56	2,870	4.078
3	27,781	1.569	30	8,060	3.059	57	2,795	4.098
4	26,794	1.608	31	7,79,	3.095	58	2,721	4.118
5	25,400	1.667	32	7,415	3.157	59	2,576	4.157
6	24,101	1.725	33	7,168	3.196	60	2,504	4.176
7	22,888	1.784	34	6,809	3.255	61	2,433	4.196
8	21,752	1.843	35	6,577	3.294	62	2,363	4.216
9	20,687	1.902	36	6,239	3.353	63	2,293	4.235
10	19,685	1.961	37	6,020	3.392	64	2,156	4.275
11	19,050	2.000	38	5,806	3.431	65	2,088	4.294
12	18,143	2.059	39	5,597	3.471	66	2,020	4.314
13	17,286	2.118	40	5,392	3.510	67	1,954	4.333
14	16,476	2.176	41	5,094	3.569	68	1,888	4.353
15	15,708	2.235	42	4,901	3.608	69	1,822	4.373
16	14,979	2.294	43	4,711	3.647	70	1,758	4.392

Triac Driving(4)

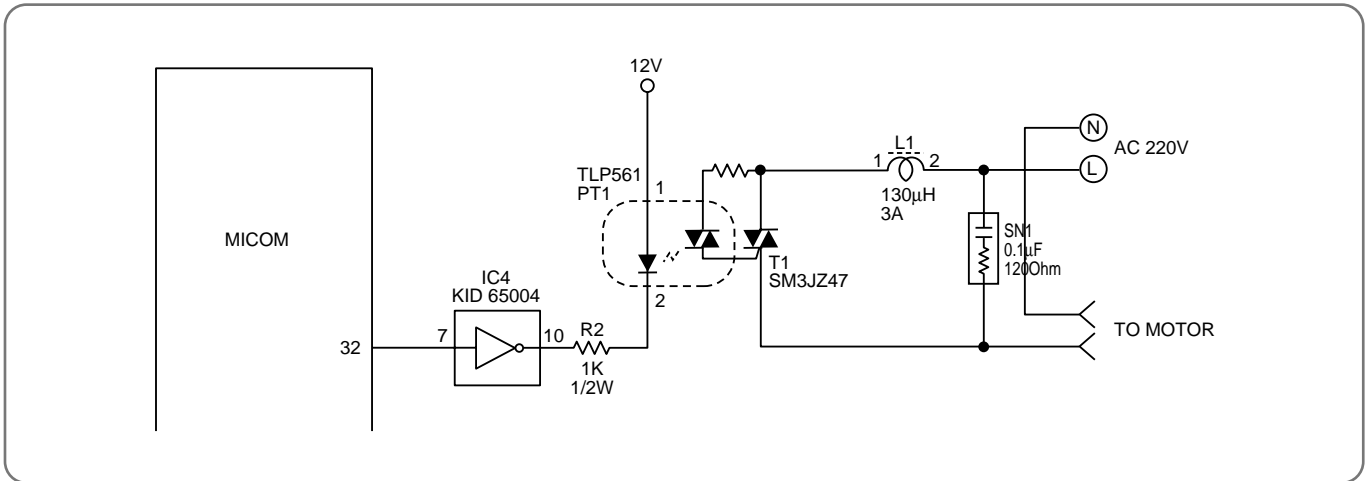

DESCRIPTION

Number 32 Terminal of Micom is put out Pulse Output, by way of Buffer it is driving Photo Triac is supplied Trigger Signal.

Trigger Test of Triac is detected Zero Cross Part of AC input and it is triggered from Zero Cross part to Time delay part according to Fan Speed. (Ref. Fig 4-1) SN1 is Snubber.

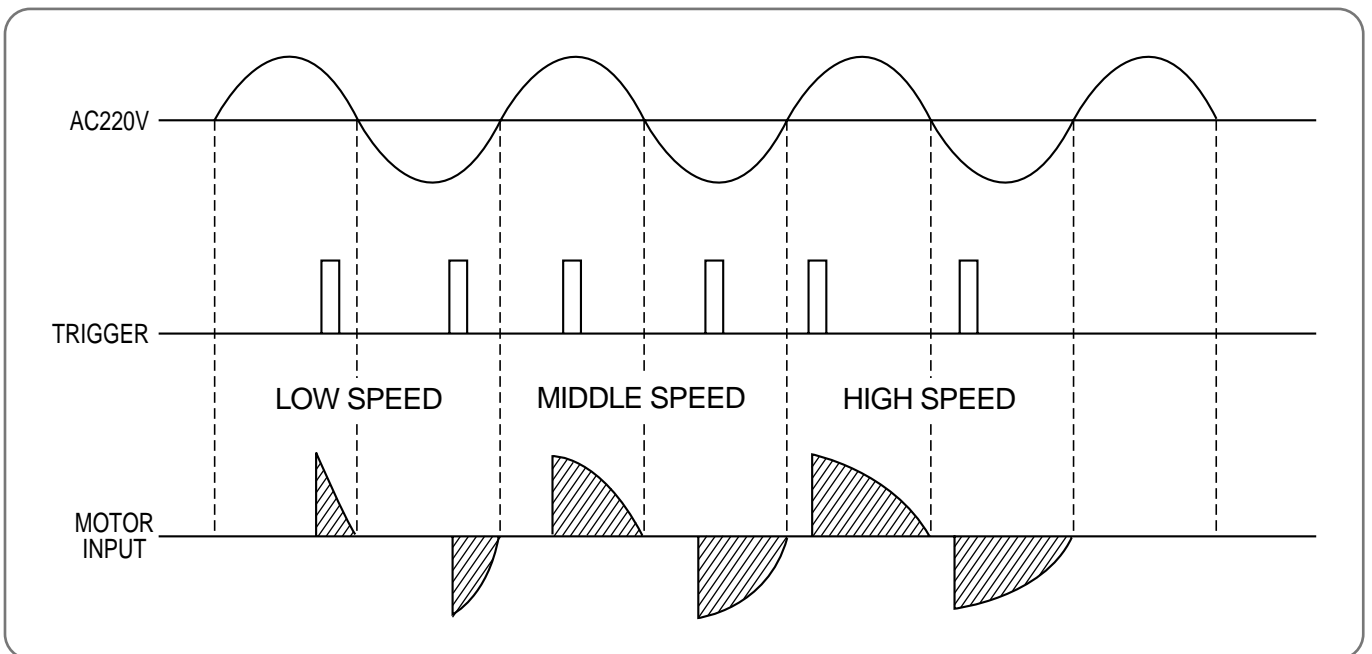

Fig 4-1

Remote Controller(5)

DESCRIPTION

Signal from Remote Controller put in only Control Data Signal at Micom Terminal of Number 33, which is gotten from Carrier (38KHz) from Receive Module. Signal Wave repeat third as following Fig 5-1. But in Secondary Wave Custom Code is Reversed Face.

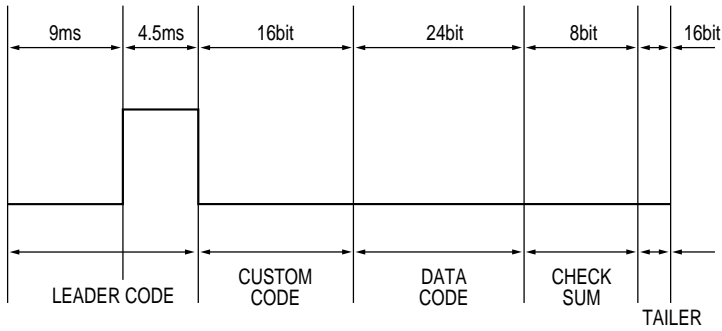

Fig 5-1

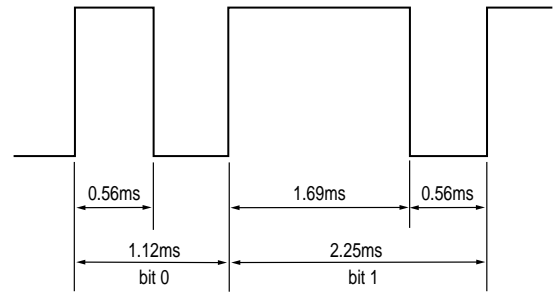
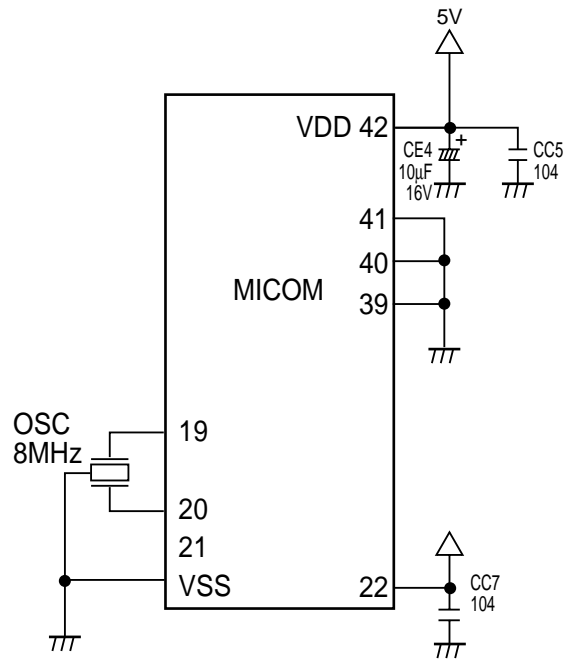

Fig 5-2
BIT STRUCTURE

Micom Power Supply(7)



DESCRIPTION

MICOM Power is supplied 5V at Number 42 using VDD, Number 19, 20 Using Oscillator, CC7 is noise filter.

Reset(8)

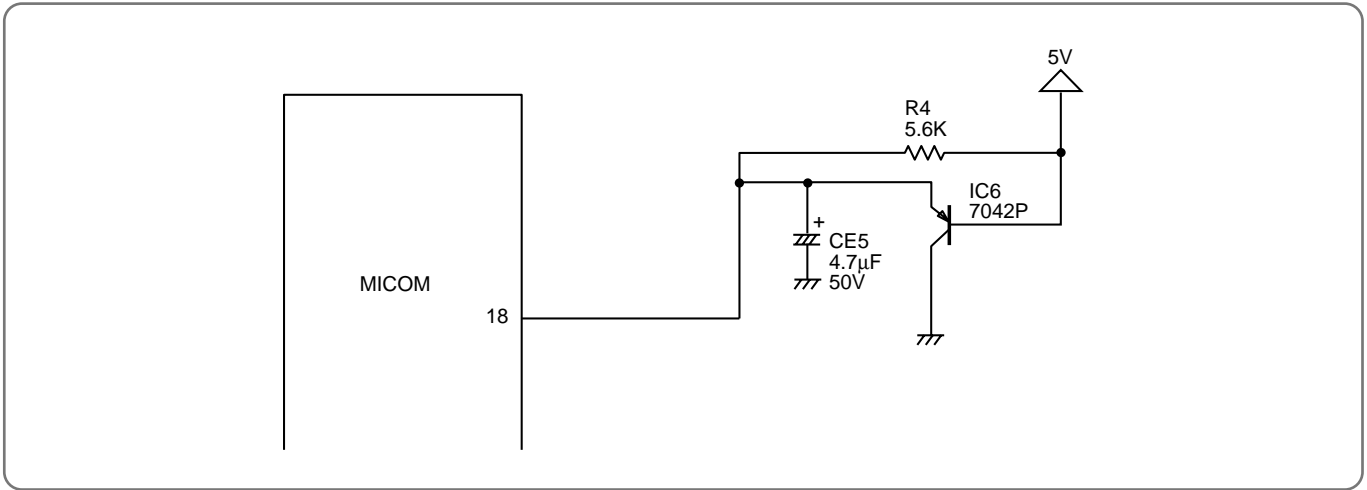

DESCRIPTION

Voltage less than about 0.8V put in Micom Terminal of Number 18 and then Micom reset. Reset IC detect Power ON and Voltage less than 4.25V, and then send Reset Signal.

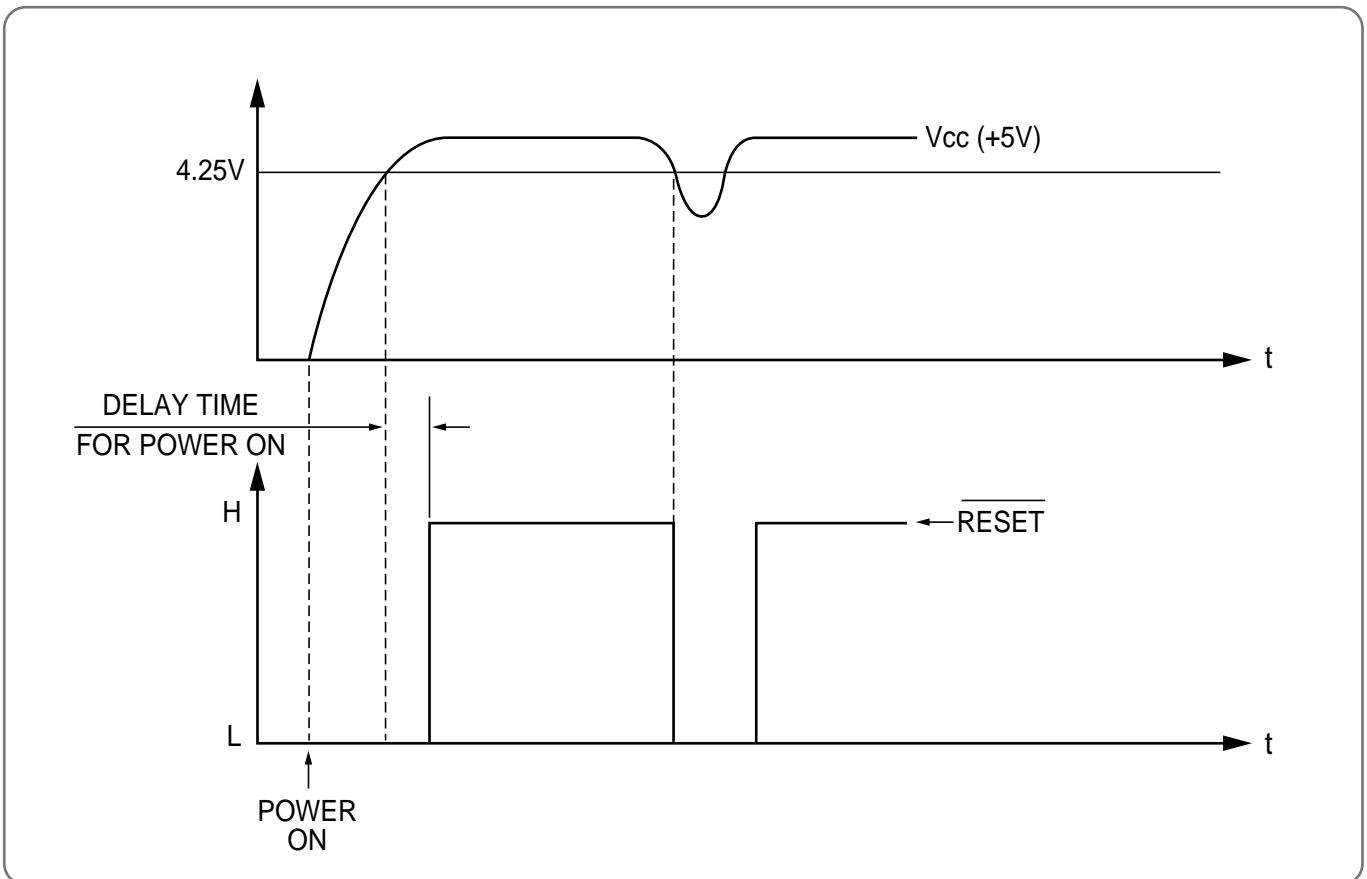

Function Selecting(9)

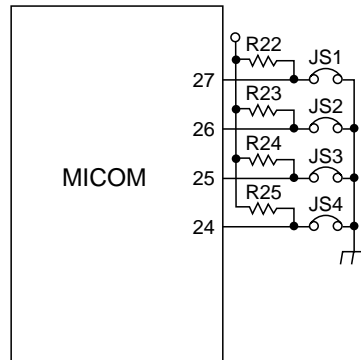

DESCRIPTION

Selecting function is as following table 9-1.

* When power source is put at first, Function selection input is recognized.

And when the unit is running the microcomputer ignore variation of function selection input.

	SHORT	OPEN
JS1	SIMPLE	LCD
JS2	132	180
JS3	MILD	HIGH
JS4	Heat Pump	Cooling Only

Table 9-1

Buzzer Driving(10)

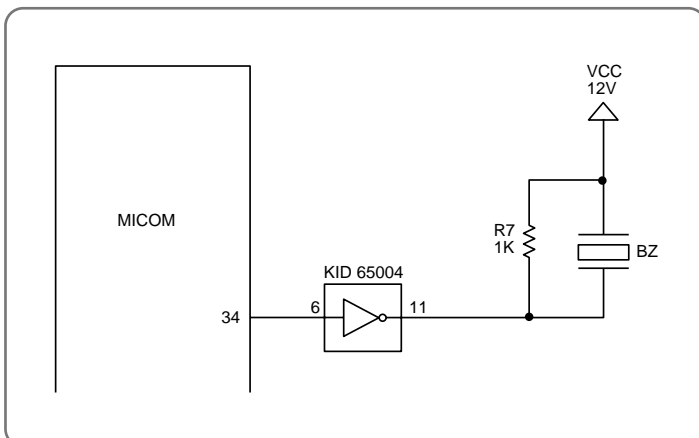

DESCRIPTION

Micom 34 Terminal put out Buzzer Driving Pulse, its output is driving Buzzer through Buffer.

Oscillatory Frequency of buzzer is selected by internal Micom.

This unit is setting at 2KHz.

Zero Crossing Detect(11)

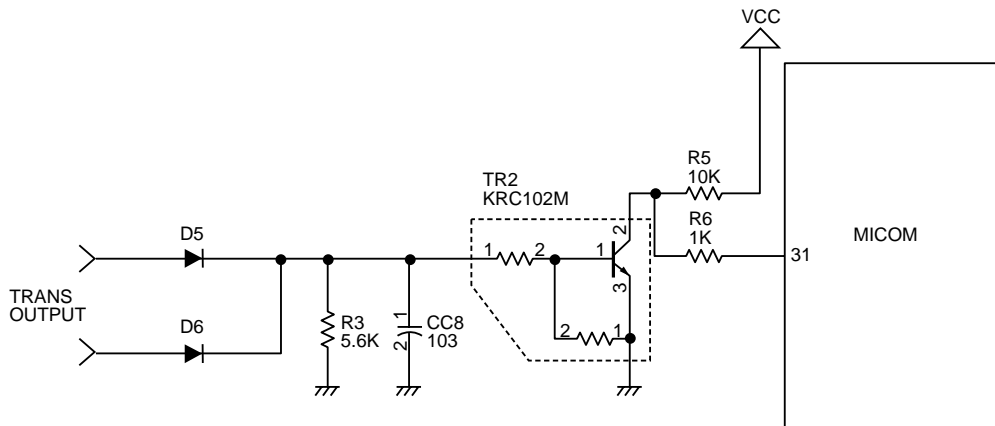

DESCRIPTION

It detect Zero Cross part of Trans output voltage, Transistor TR2 is used to put in the Micom. Detail Driving is as following Fig 11-1.

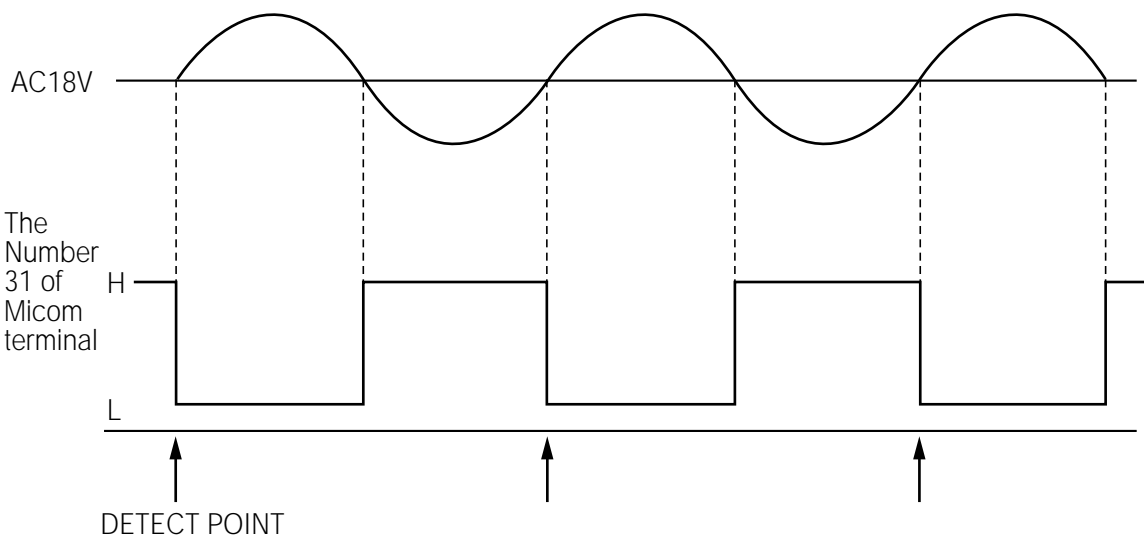
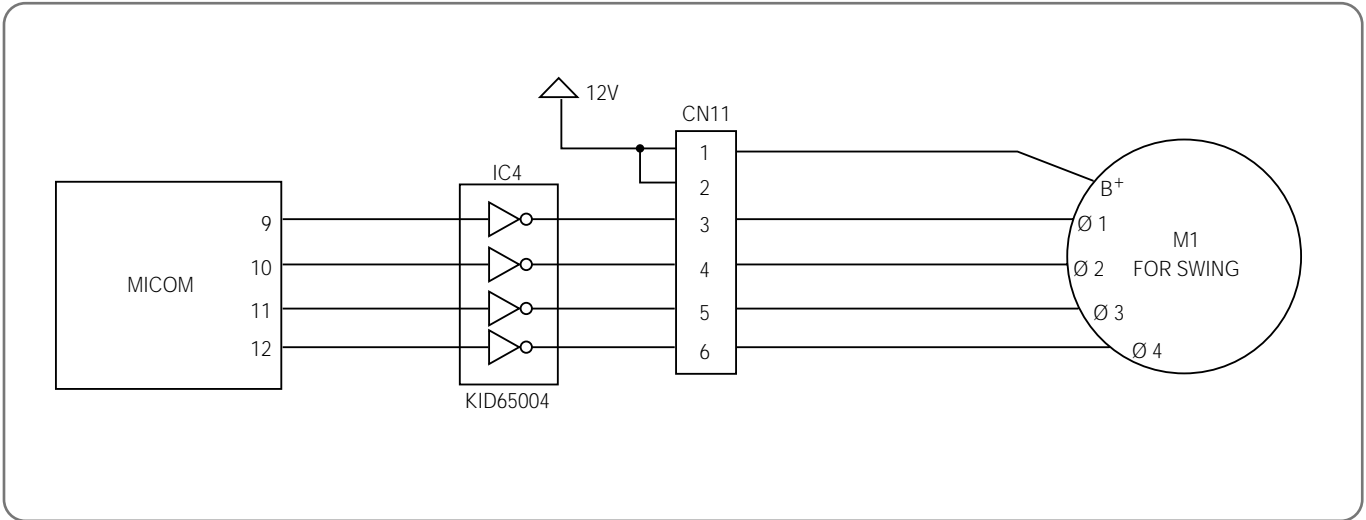

Fig 11-1

Stepping Motor Driving(12)



DESCRIPTION

There are one Stepping Motor for Flap (up and down) and it is used 4 face Drive Method. It is driving as following Fig 12-1. (Ring Count Method of 8 Status)

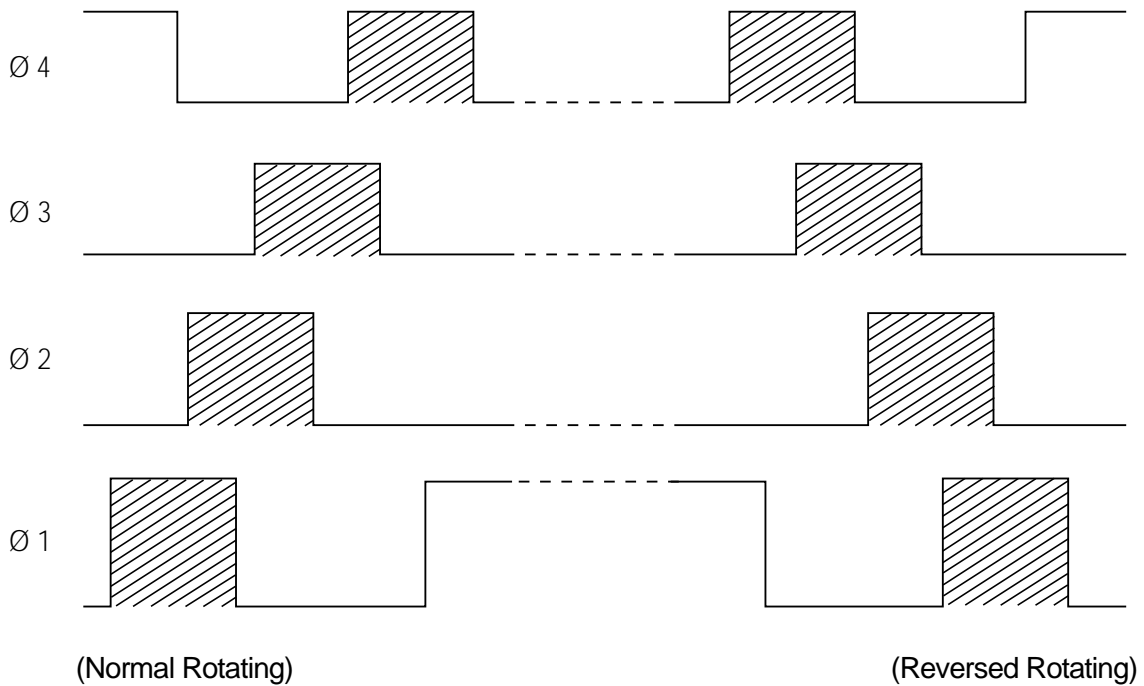
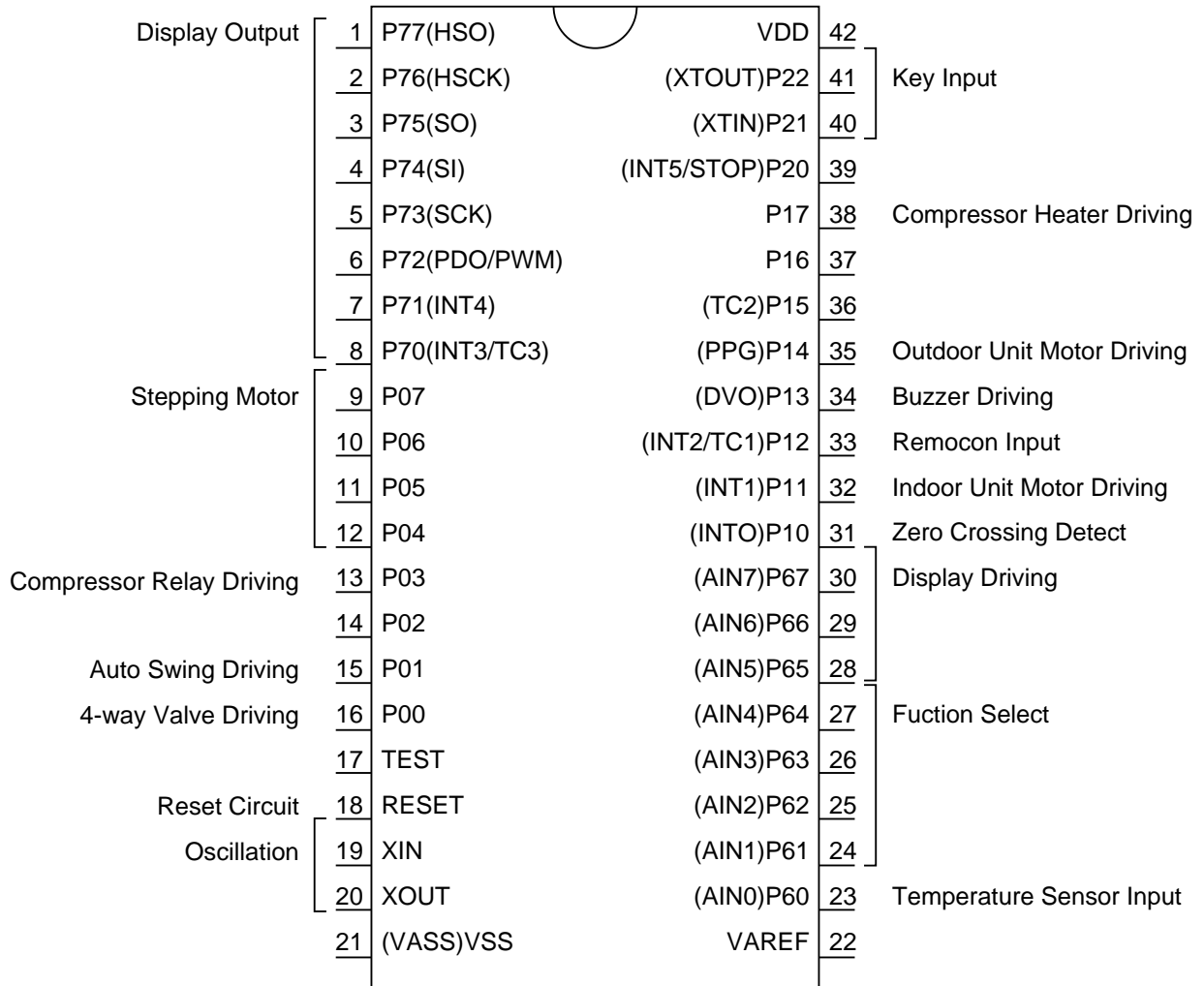
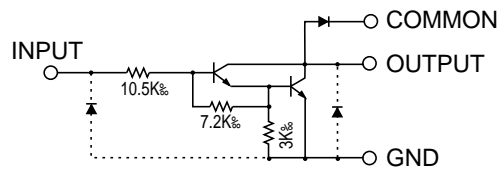
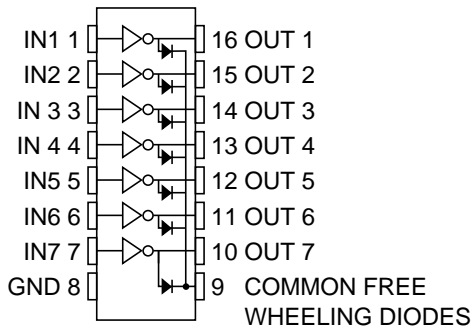

Fig 12-1

MICOM



DARLINGTON ARRAYS (KID65004)



VOLTAGE REGULATOR (KIA7805AP-5VDC)

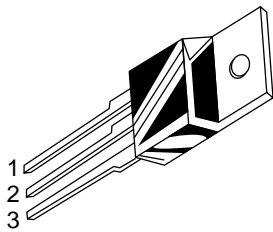

SCHEMATIC DIAGRAM

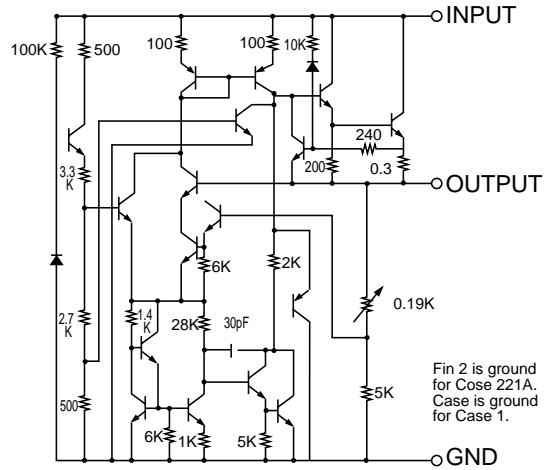

VOLTAGE REGULATOR (KIA7812AP-12VDC)

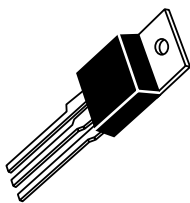

Pin 1. INPUT
 2. GROUND
 3. OUTPUT

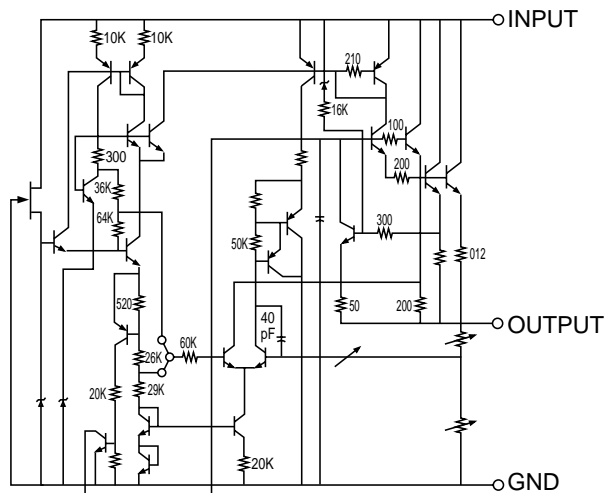

(Equivalent Circuit)

RESET IC (KIA 7042P)

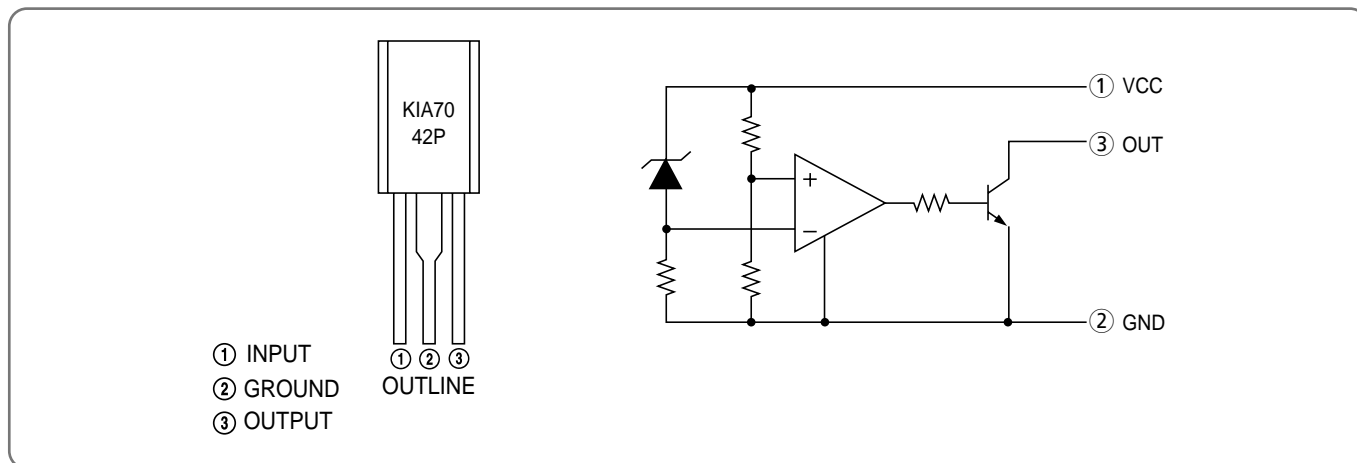

6. REFRIGERANT CYCLE

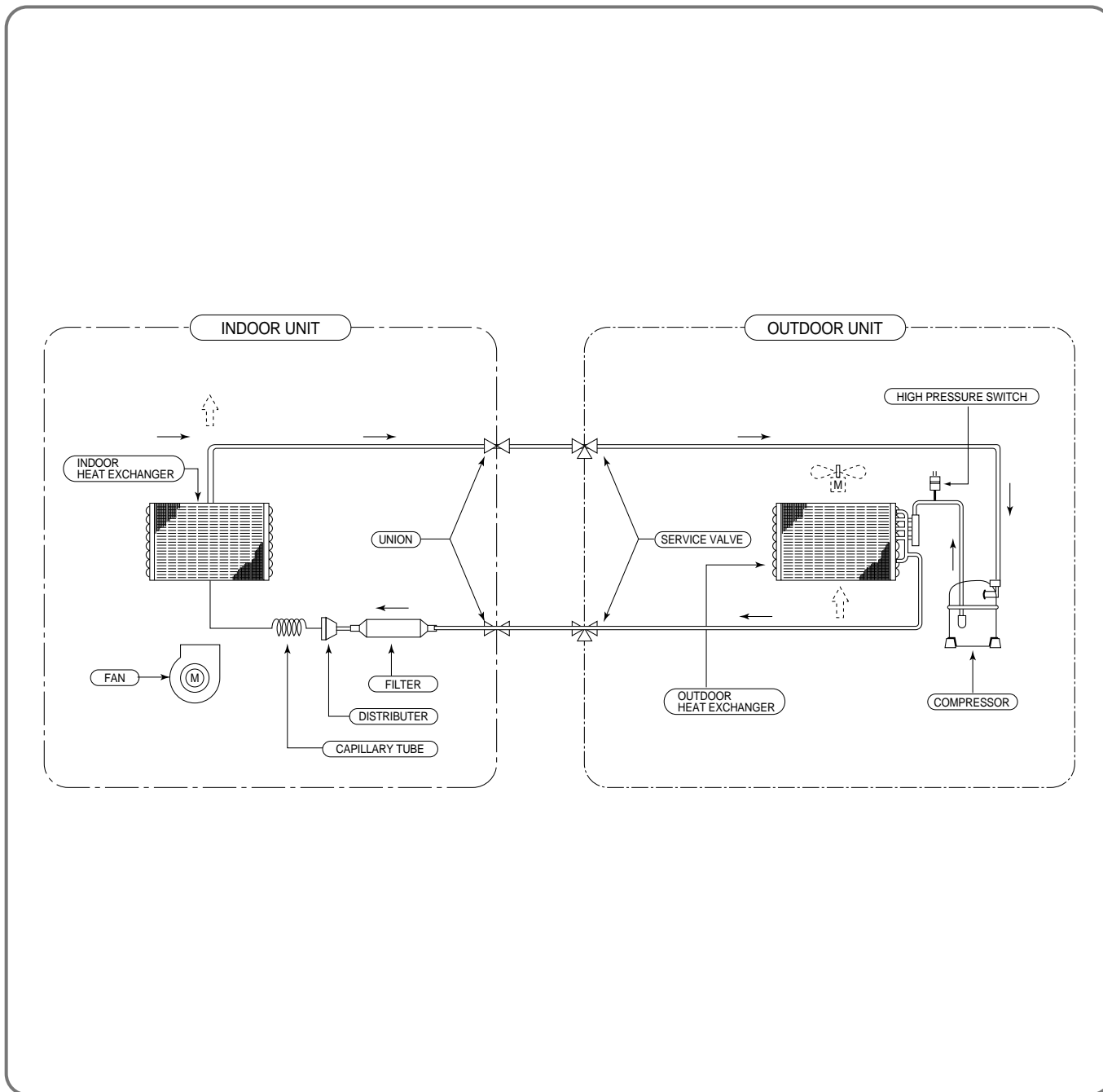

Note) If the pipe length exceeds the standard length, add 30g of refrigerant per extra meter.

Model Name	Cooling	Heating
Contents		
Capillary tube(x L x)	IDØ1.4 x 1000mm(6.0 /min) x 5EA	ODØ2.0 x 250mm
Charge Quantity	2000 g	

7. TROUBLE SHOOTING

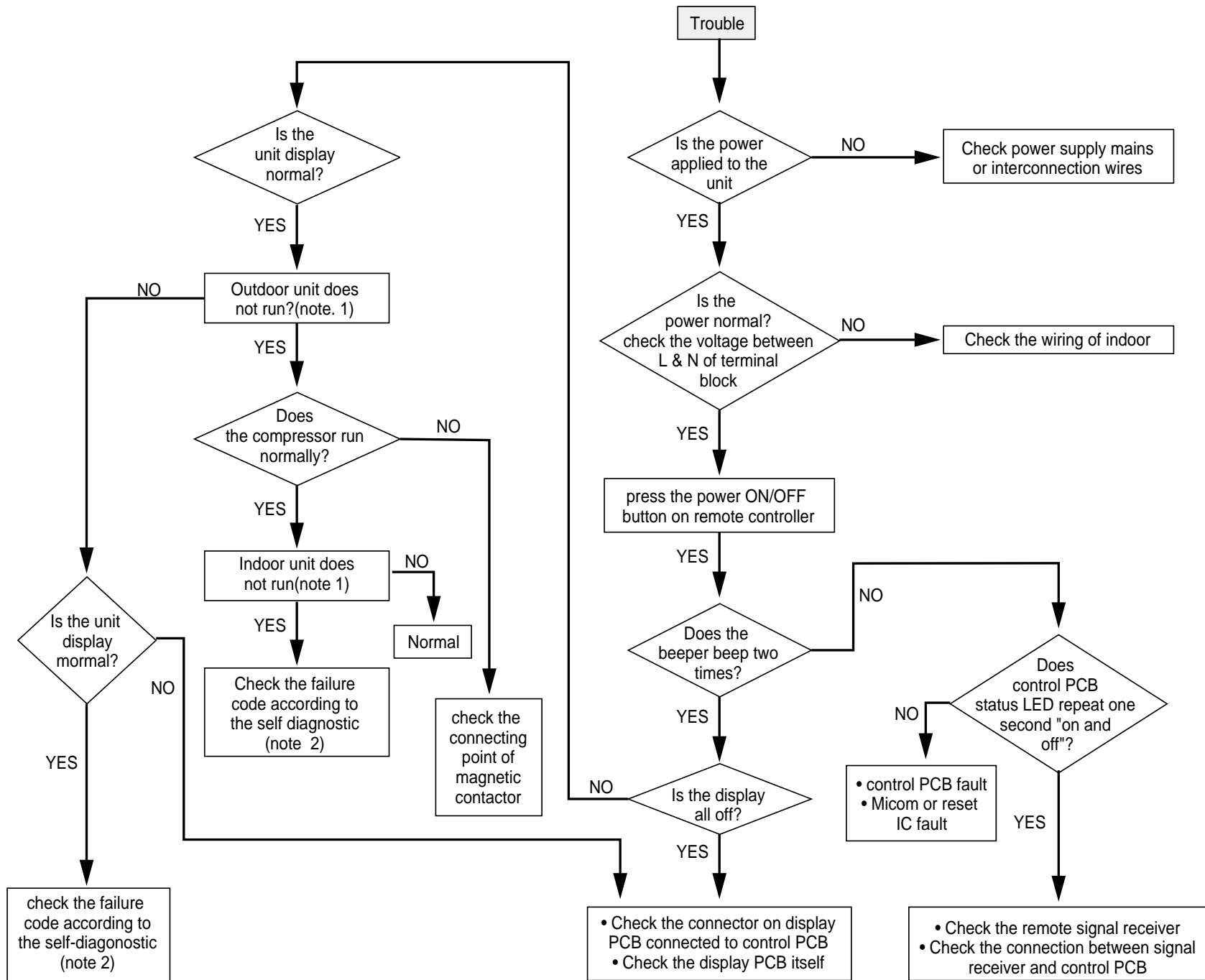

1 Neither Indoor Unit nor Outdoor Unit Runs

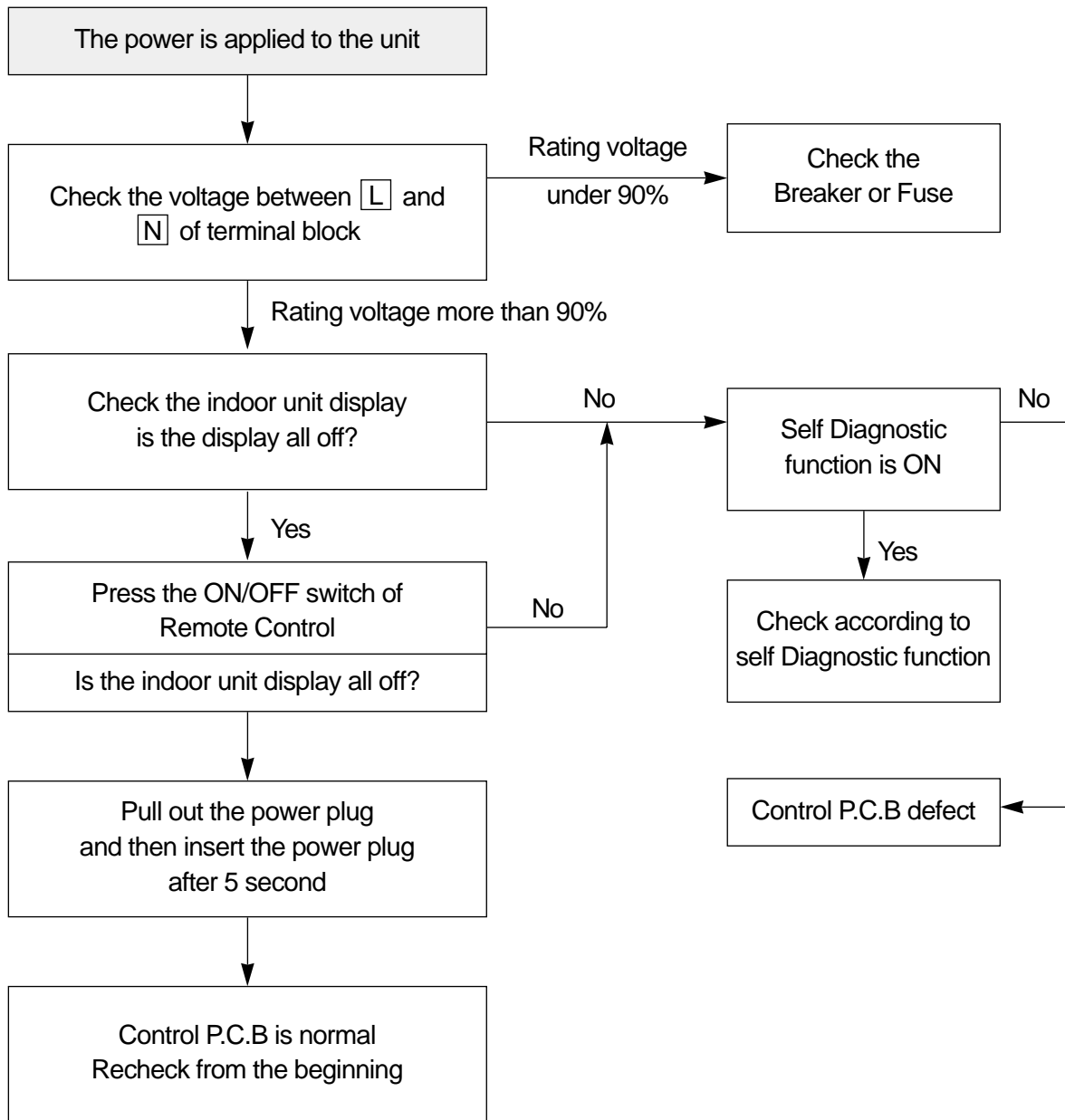

2

Outdoor Unit Runs but Indoor Unit Do Not Run

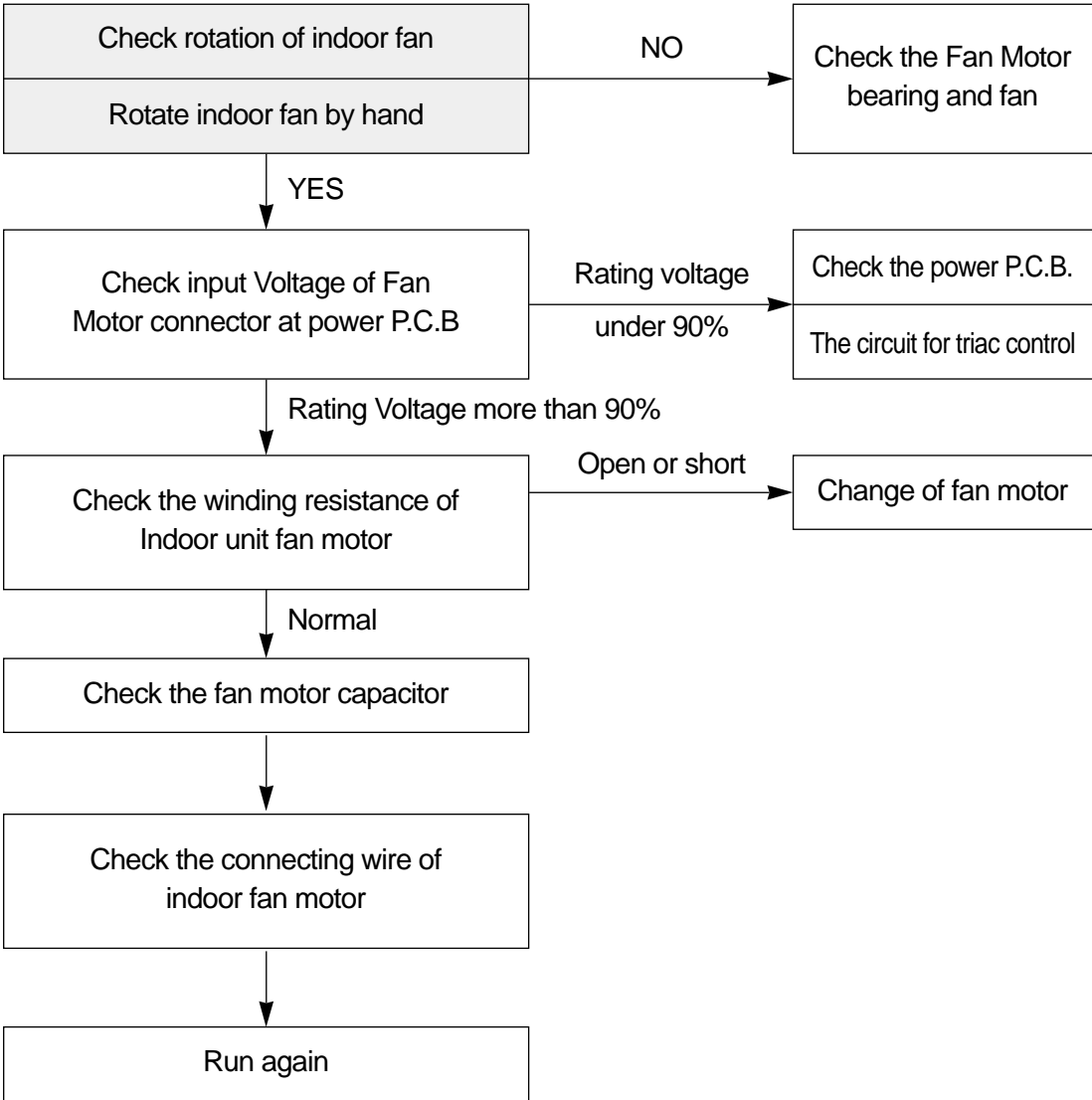

3 Outdoor Fan Do Not Run

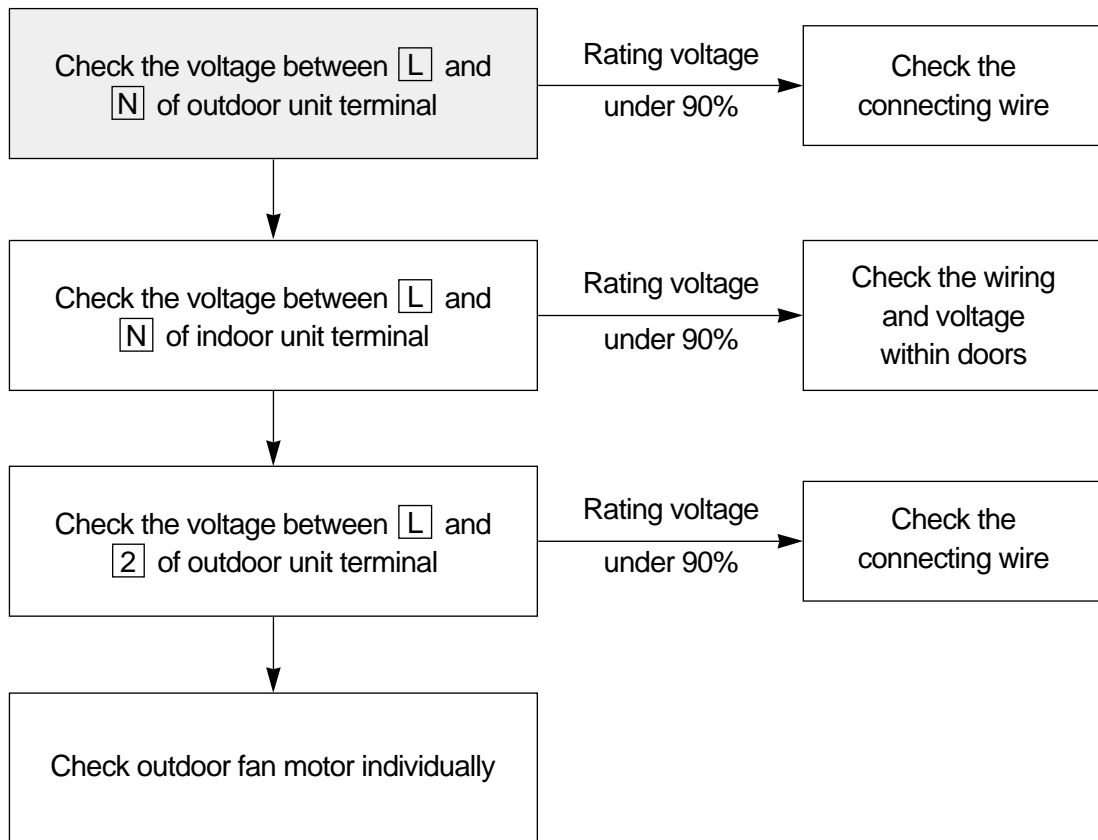

4 Only Compressor Do not Run

- Check the following at cooling mode

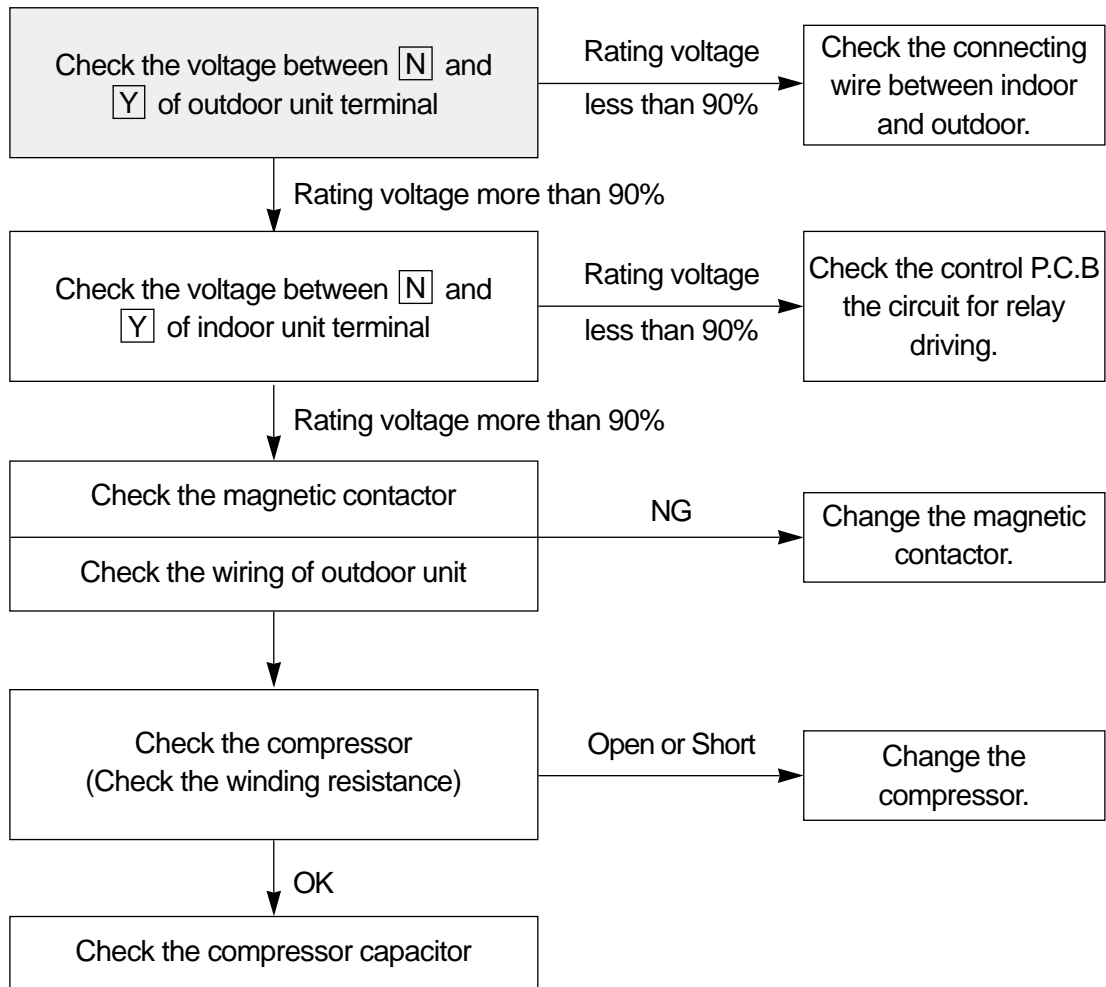

5

REMOTE CONTROLLER ASSMBLY FUNCTIONAL TEST METHOD

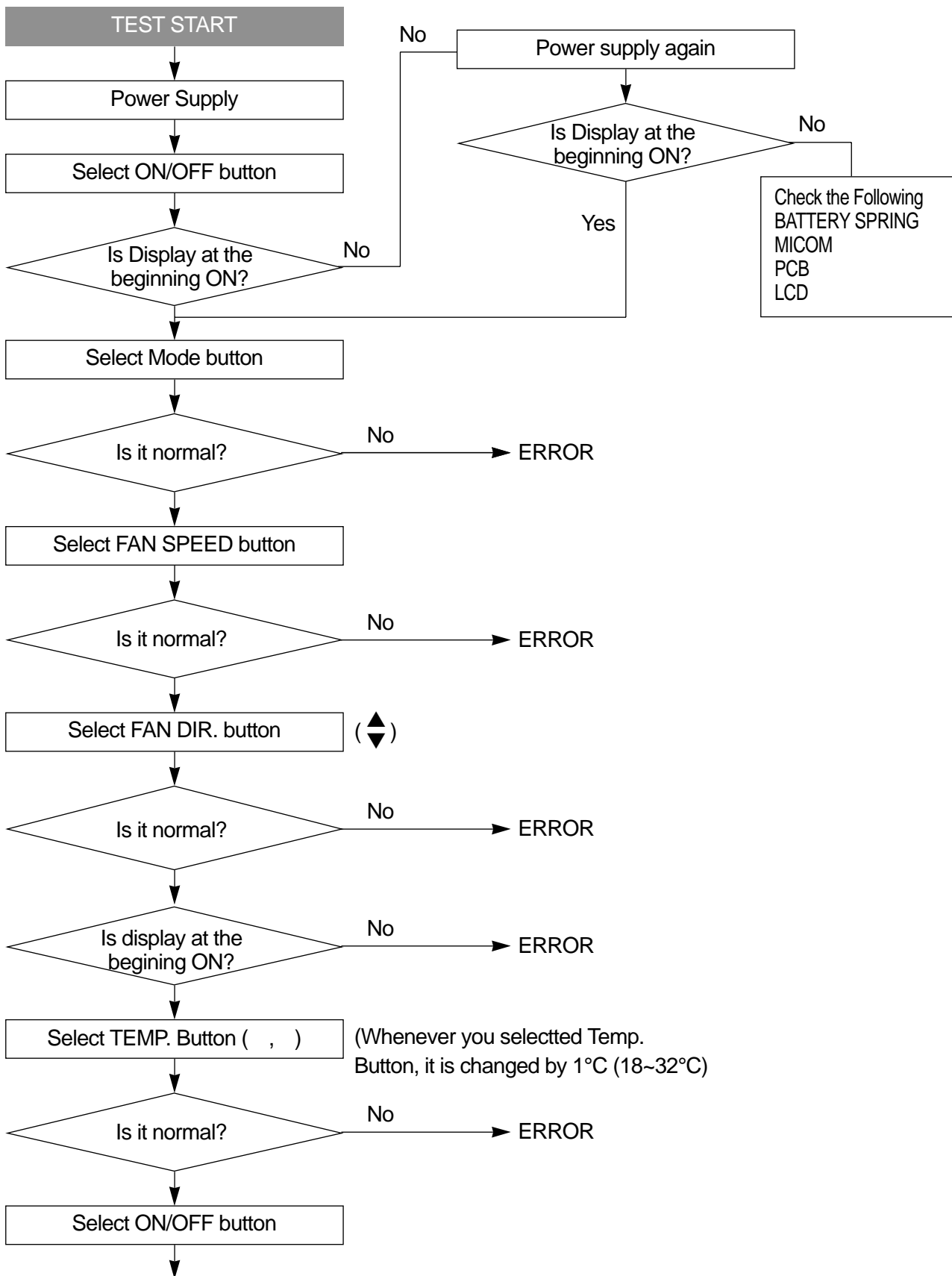

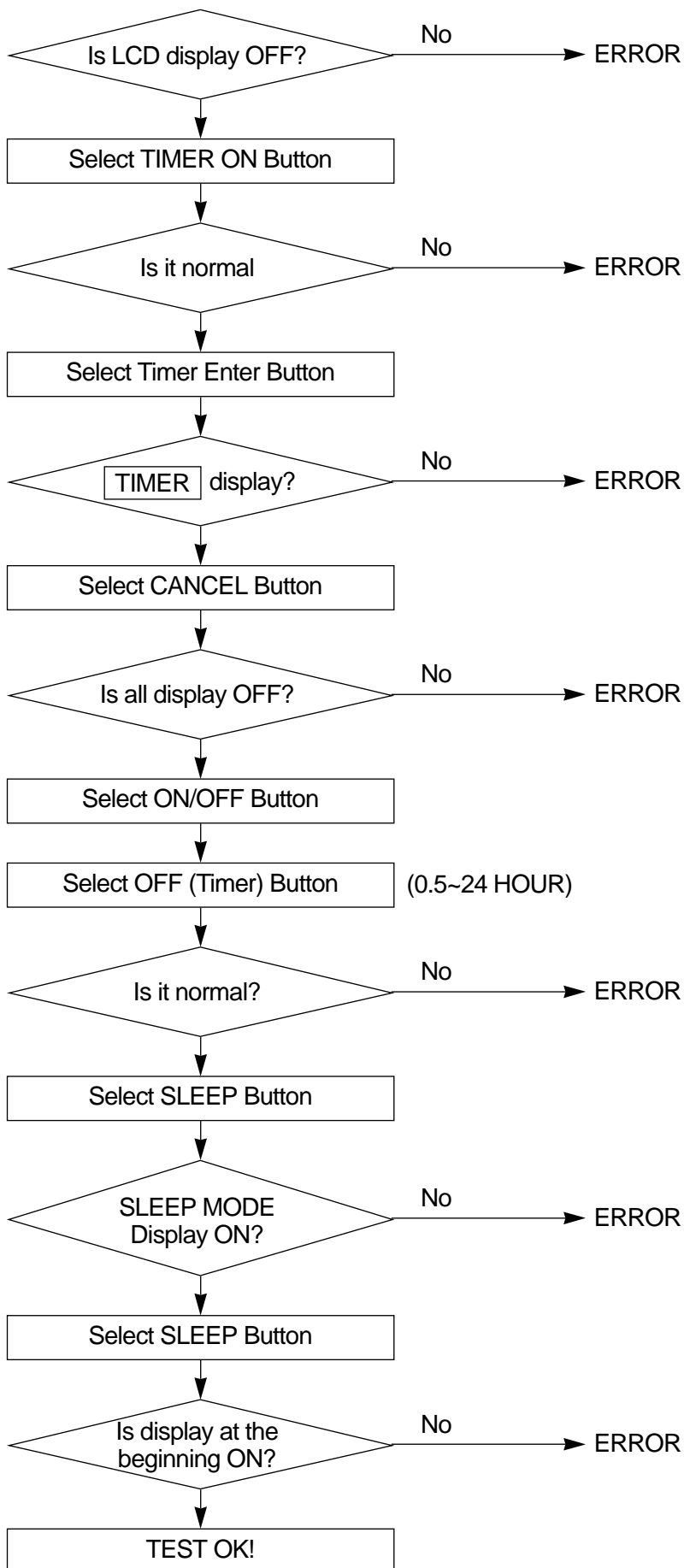

8. EXPLODED DIAGRAM

1 INDOOR UNIT

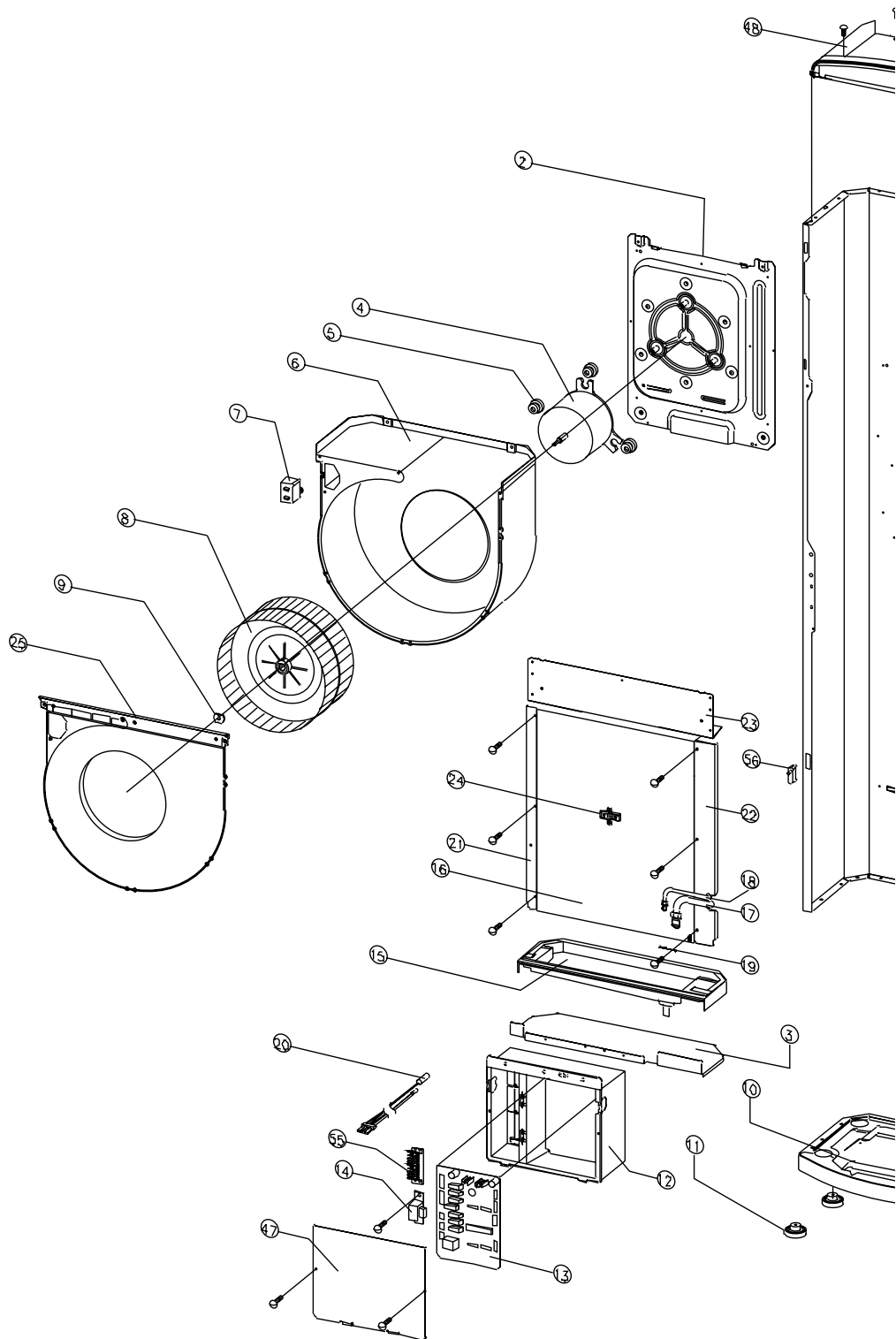

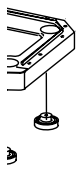
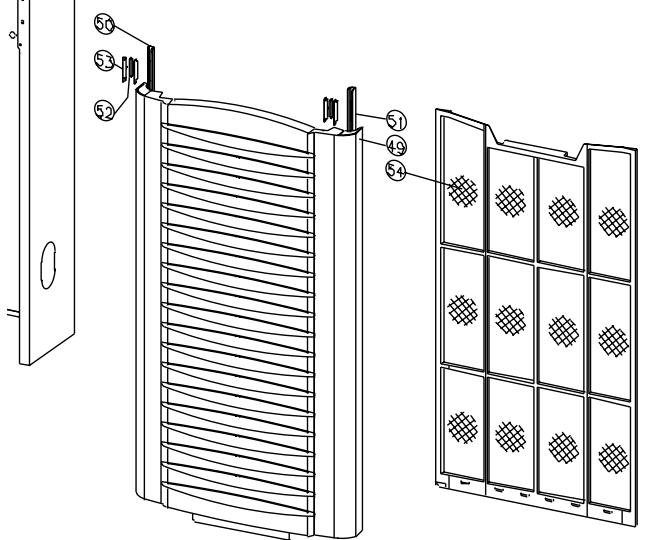
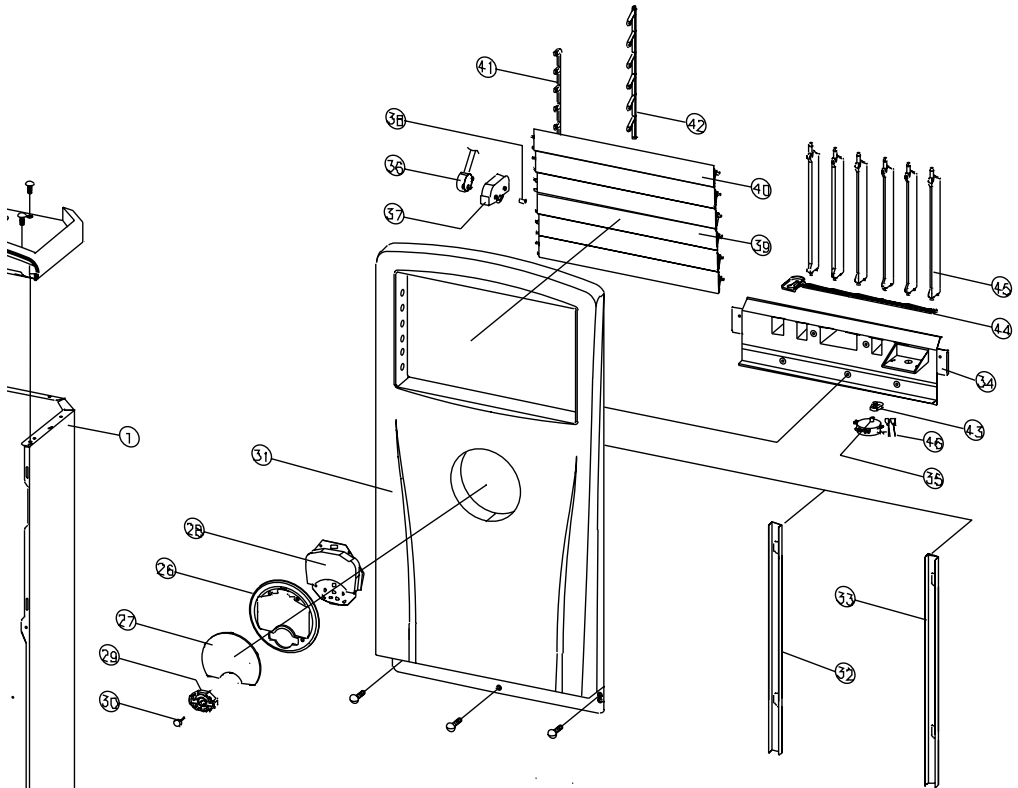

NO	Part Code	Part Name	Quantity	Remarks
1	3100090100	ASSY CABNET BODY	1	
2	3100042301	BASE MOTOR ASSY	1	
3	3100602801	BRACKET PAN DRAIN	1	
4	3108008600	MOTOR IDU	1	
5	3101501900	CUSHION MOTOR	3	
6	3106600210	SCROLL HOUSING	1	
7	3106903100	CAPACITOR MOTOR IDU	1	
8	3100025000	BLOWER ASSY	1	
9	3105200300	WASHER STOPPER	1	
10	3100301600	BASE	1	
11	3101501100	CUSHION BASE	4	
12	3100503901	BOX CONTROL	1	
13	3104398800	ASSY MAIN PCB	1	
14	5EPK560120	TRANS	1	
15	3100042501	PAN DRAIN ASSY	1	
16	3100042603	EVAPORATOR ASSY	1	
17	3100042802	PIPE DISCHARGE ASSY	1	
18	3100042903	PIPE SUCTION ASSY	1	
19	3105100400	SPRING SENSOR	1	
20	3102707930	HARNES COIL SENSOR	1	
21	3101402700	COVER EVAP. L	1	
22	3100048310	ASSY COVER EVAP. R	1	
23	3100043000	COVER EVAP. TOP ASSY	1	
24	3107000400	CLIP THERMO	1	
25	3100087200	COVER HOUSING ASSY	1	
26	3104202700	PANEL CONTROL	1	
27	3105501800	WINDOW	1	
28	3104301010	ASSY CONTROL PCB	1	
29	3103401510	KNOB SELECTION	1	
30	3103401610	KNOB POWER	1	
31	3100090620	ASSY PANEL FRONT	1	
32	3100604700	BRACKET FRONT L	1	

NO	Part Code	Part Name	Quantity	Remarks
33	3100604800	BRACKET FRONT R	1	
34	3102201600	FRAME DISCHARGE	1	
35	310P40086E	SWING MOTOR ASSY	1	
36	3108005300	MOTOR STEPPING	1	
37	3101101300	CASE MOTOR	1	
38	3100702100	BUSHING MOTOR	1	
39	3106501430	BLADE HORIZONTAL 1	5	
40	3106501530	BLADE HORIZONTAL 2	1	
41	3107801000	LINK GUIDE R	1	
42	3107802200	LINK M	1	
43	3106700100	CAM	1	
44	3106301100	BAR VERTICAL	1	
45	3106503000	BLADE VERTICAL	6	
46	3101203400	PUSH MOUNT TIE	2	
47	3101408000	COVER BOX CONTROL	1	
48	3100090200	ASSY COVER TOP	1	
49	3102403720	GRILLE SUCTION	1	
50	3102500901	GUIDE FILTER L	1	
51	3102501001	GUIDE FILTER R	1	
52	3107900100	MAGNET	4	
53	3104504700	PLATE MAGNET	8	
54	3100056510	FILTER AIR ASSY	1	
55	3108912340	TERMINAL BLOCK	1	

2 OUTDOOR UNIT

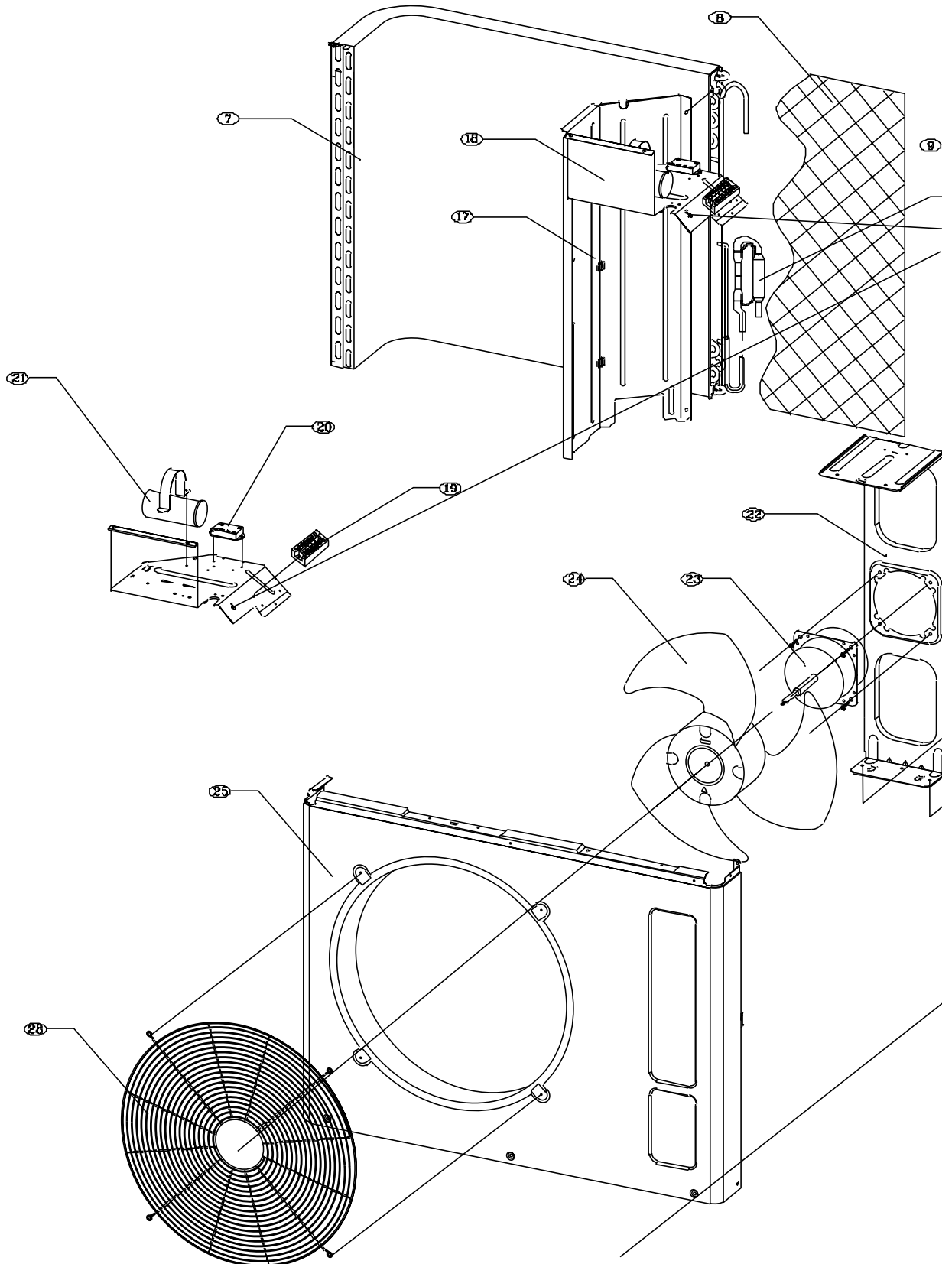

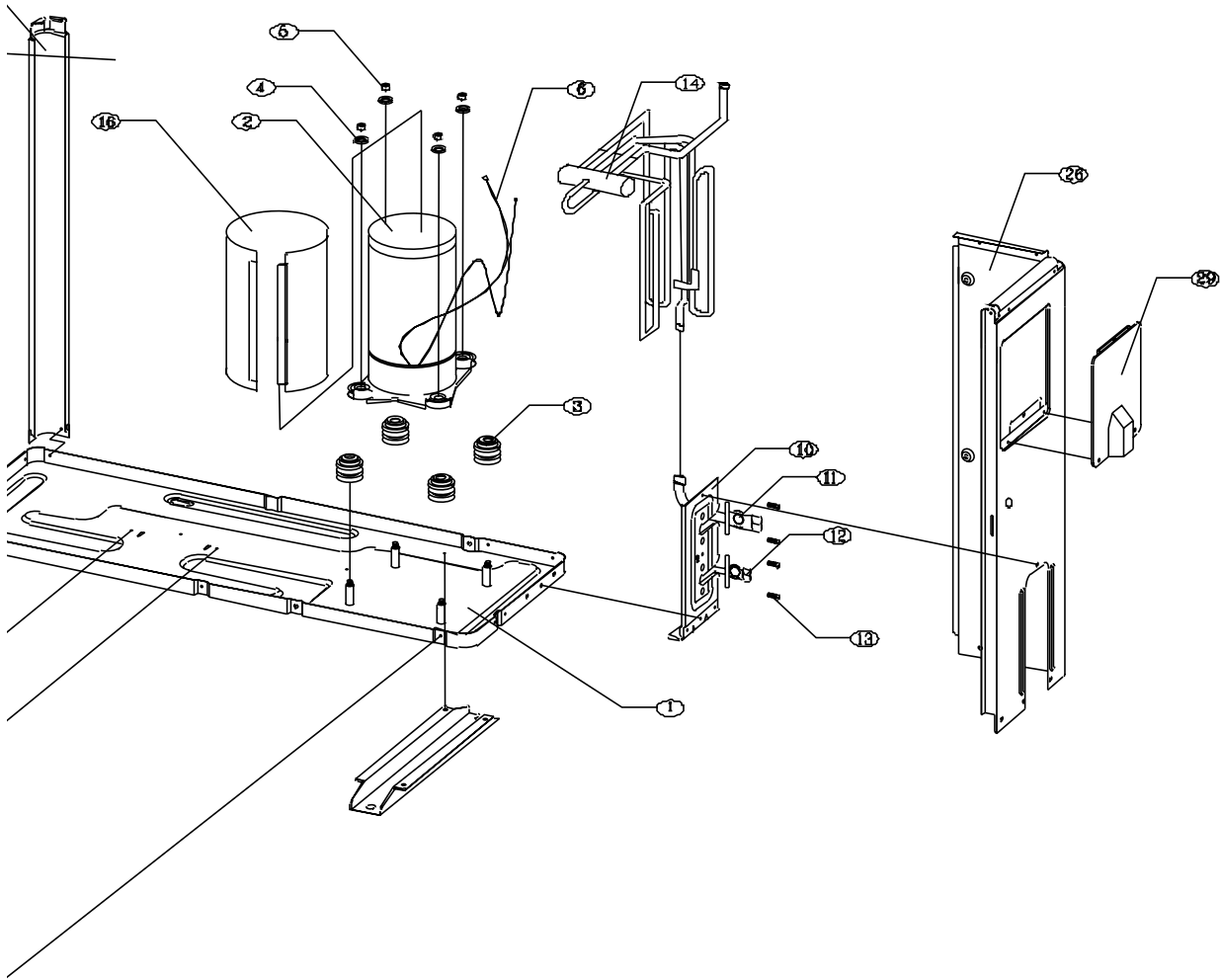
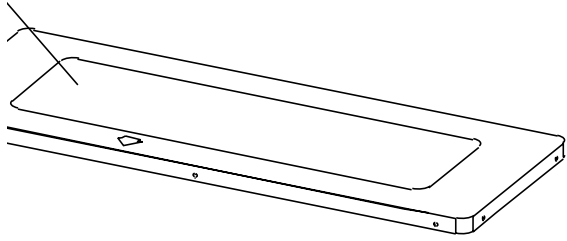

NO	Part Code	Part Name	Quantity	Remarks
1	3100041704	BASE PAN PAINT ASSY	1	
2	3107103000	COMPRESSOR ASSY	1	
3	3107103200	CUSHION COMP	4	
4	7400208411	WASHER PLAIN	4	
5	7392801211	NUT LOCK	4	
6	3102800300	CRANKCASE HEATER	1	
7	3100031223	CONDENSER ASSY	1	
8	3102402100	GRILLE COND	1	
9	3100041100	GUIDE POST P/T ASSY	1	
10	3100041201	BRK SERVICE P/TAS	1	
11	3105401300	SERVICE VALVE G	1	
12	3105401200	SERVICE VALVE L	1	
13	3106002300	BOLT HEX	4	
14	3100086810	PIPE REVERSING ASSY	1	
15	3100079310	PIPE FILTER ASSY	1	
16	3101407900	COMP COVER	1	
17	3100031702	PLT PARTITION ASSY	1	
18	3104201601	PANEL CONTROL	1	
19	3108912340	TERMINAL BLOCK	1	
20	5SC0202700	POWER RELAY	1	
21	3109508000	CAPACITOR DUAL	1	
22	3105300400	SUPPORT MOTOR	1	
23	3108008500	MOTOR ODU	1	
24	3101802001	FAN PROPELLER	1	
25	3100031400	CABINET FRONT P/T AS	1	
26	3100031500	CABINET SIDE P/T AS	1	
27	3100041400	PANEL TOP ASS'Y	1	
28	3102102000	GRILLE DISCHARGE	1	
29	3101402500	COVER SERVICE	1	

DAEWOO

DAEWOO ELECTRONICS CO., LTD.

686, AHYEON-DONG MAPO-GU SEOUL, KOREA

C.P.O. BOX 8003 SEOUL, KOREA

TELEX: DWELEC K28177-8

CABLE: "DAEWOOELEC"

FAX: 02) 360-8184

TEL: 02) 360-8182/8178~9

<http://www.dwe.daewoo.co.kr>

PRINTED DATE: APR.1999