

WHITE

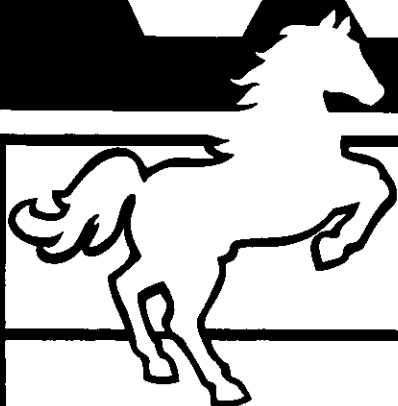

OUTDOOR POWER

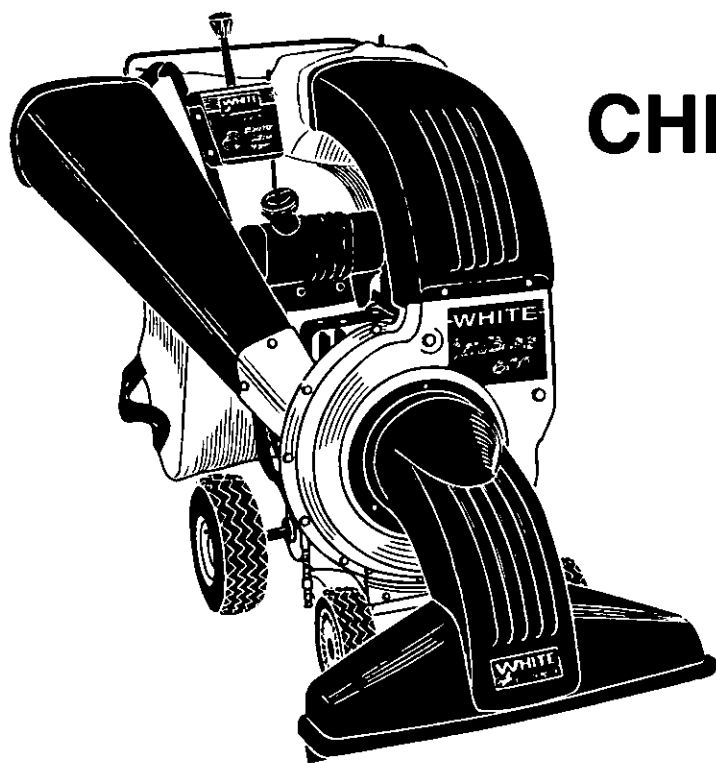

8 H.P. CHIPPER-VACUUM

Model 315B

Thank you for purchasing an American-built product.

WARNING: This unit is equipped with an internal combustion engine and should not be used on or near any unimproved forest-covered, brush-covered or grass-covered land unless the engine's exhaust system is equipped with a spark arrester meeting applicable local or state laws (if any). If a spark arrester is used, it should be maintained in effective working order by the operator.

In the State of California the above is required by law (Section 4442 of the California Public Resources Code). Other states may have similar laws. Federal laws apply on federal lands. A spark arrester for the muffler is available through your nearest engine authorized service dealer or contact the Service Department of White Outdoor Products, P.O. Box 361131, Cleveland, Ohio 44136-0019.

IMPORTANT

SAFE OPERATION PRACTICES

THIS SYMBOL POINTS OUT IMPORTANT SAFETY INSTRUCTIONS WHICH, IF NOT FOLLOWED, COULD ENDANGER THE PERSONAL SAFETY AND/OR PROPERTY OF YOURSELF AND OTHERS. READ AND FOLLOW ALL INSTRUCTIONS IN THIS MANUAL BEFORE ATTEMPTING TO OPERATE YOUR POWER CHIPPER-VACUUM. FAILURE TO COMPLY WITH THESE INSTRUCTIONS MAY RESULT IN PERSONAL INJURY. WHEN YOU SEE THIS SYMBOL—  **HEED ITS WARNING.**



DANGER:

Your chipper-vacuum was built to be operated according to the rules for safe operation in this manual. As with any type of power equipment, carelessness or error on the part of the operator can result in serious injury. This unit is capable of amputating fingers and hands and throwing objects. Failure to observe the following safety instructions could result in serious injury or death.

I. GENERAL OPERATION

1. Read this owner's guide carefully in its entirety before attempting to assemble this machine. Read, understand, and follow all instructions on the machine and in the manual(s) before operation. Be completely familiar with the controls and the proper use of the machine before operating it. Keep this manual in a safe place for future and regular reference and for ordering replacement parts.
2. Your chipper-vacuum is a powerful tool, not a plaything. Therefore, exercise extreme caution at all times. Your unit has been designed to perform two jobs; to chip and vacuum vegetation found in a normal yard. Do not use it for any other purpose.
3. Never allow children under 16 to operate the unit. Children 16 years and older should only operate under close parental supervision. Only responsible individuals who are familiar with these rules of safe operation should be allowed to use your unit.
4. Keep the area of operation clear of all persons, particularly small children and pets. Stop the engine when they are in the vicinity of the unit.
5. When feeding material into this equipment, be extremely careful that pieces of metal, rocks, bottles, cans or other foreign objects are not included. Personal injury or damage to the machine could result.
6. Always wear safety glasses or safety goggles, during operation and while performing an adjustment or repair, to protect eyes from foreign objects that may be thrown from the machine.
7. Wear sturdy, rough-soled work shoes and close fitting slacks and shirt. Shirt and slacks that cover the arms and legs and steel-toed shoes are recommended. Do not wear loose fitting clothes or jewelry and secure hair so it above shoulder length. They can be caught in moving parts. Never operate a unit in bare feet, sandals or sneakers. Wear gloves when feeding material in the chipper chute.
8. Do not operate the unit while under the influence of alcohol or drugs.
9. Do not over-reach. Keep proper footing and balance at all times.
10. Never place your hands or any part of your body or clothing near or under rotating parts. Keep clear of the discharge opening at all times. Never insert your hands or any part of your body or clothing into the nozzle, chipper chute or discharge opening as the rotating impeller can cause serious injury.
11. If it is necessary for any reason to unclog the feed intake or discharge openings or to inspect or repair any part of the machine where a moving part can come in contact with your body or clothing, stop the machine, allow it to cool, disconnect the spark plug wire from the spark plug and move it away from the spark plug before attempting to unclog, inspect or repair.
12. Never operate unit without vacuum bag and discharge chute properly affixed to unit. Large zippered end of bag must be closed to prevent objects from being blown out.
13. Never operate unit without either the inlet nozzle or optional hose attachment properly affixed to unit. These devices shield the operator from accidental contact with the rotating impeller. Never attempt to convert the unit from nozzle to hose mode or vice versa with the engine running.
14. Never attempt to remove or empty vacuum bag when engine is running. Shut the engine off and wait for the impeller to come to a complete stop before removing the bag. The impeller continues to rotate for a few seconds after the engine is shut off. Never place any part of the body in the impeller area until you are sure the impeller has stopped rotating.
15. Keep all guards and safety devices in place and operating properly.
16. Do not allow an accumulation of processed material to build up in the discharge area as this will prevent proper discharge and can result in kick-back from the chipper chute.
17. Keep your face and body back from chipper chute to avoid accidental bounce back of any material.
18. If the cutting mechanism strikes a foreign object or if your machine should start making an unusual noise or vibration, immediately stop the engine, disconnect the spark plug wire and move the wire away from the spark plug. Allow the machine to stop and take the following steps.
 - Inspect for damage
 - Repair or replace any damaged parts.
 - Check for any loose parts and tighten to assure continued safe operation.
19. Muffler and engine become hot and can cause a burn. Do not touch.
20. Do not allow leaves or other debris to build up on engine's muffler. The debris could ignite and cause a fire.
21. Do not operate engine if air cleaner or cover over carburetor air-intake is removed, except for adjustment. Removal of such parts could create a fire hazard.

II. CHILDREN

Tragic accidents can occur if the operator is not alert to the presence of small children. Children are often attracted to the chipping and vacuuming activity. Never assume that children will remain where you last saw them.

1. Keep children out of the work area and under the watchful eye of a responsible adult other than the operator.
2. Be alert and turn the unit off if a child enters the area.
3. Never allow children under the age of 16 to operate the chipper-vacuum.

III. SERVICE

1. Use extreme care in handling gasoline and other fuels. They are extremely flammable and the vapors are explosive.
 - a. Store fuel and oil in approved containers, away from heat and open flame, and out of the reach of children.

- b. Check and add fuel before starting the engine. Never remove gas cap or add fuel while the engine is running. Allow engine to cool at least two minutes before refueling.
 - c. Replace gasoline cap securely and wipe off any spilled gasoline before starting the engine as it may cause a fire or explosion.
 - d. Extinguish all cigarettes, cigars, pipes and other sources of ignition.
 - e. Never refuel unit indoors because flammable vapors will accumulate in the area.
 - f. Never store the machine or fuel container inside where there is an open flame or spark such as a gas hot water heater, clothes dryer or furnace.
2. Never run your machine in an enclosed area as the exhaust from the engine contains carbon monoxide, which is a odorless, tasteless and deadly poisonous gas.
 3. To reduce fire hazard, keep engine and muffler free of leaves, grass, and other debris build-up. Clean up fuel and oil spillage. Allow unit to cool at least 5 minutes before storing.
 4. Before cleaning, repairing, or inspecting, make certain the impeller and all moving parts have stopped. Disconnect the spark plug wire and keep wire away from spark plug to prevent accidental starting. Do not use flammable solutions to clean air filter.
 5. Keep all nuts, bolts, and screws tight to be sure the equipment is in safe working condition.
 6. Never tamper with safety devices. Check their proper operation regularly.
 7. After striking a foreign object, immediately stop the engine, disconnect the spark plug wire from the spark plug, and thoroughly inspect the unit for any damage. Repair damage before starting and operating unit.
 8. Do not alter or tamper with the engine's governor setting. The governor controls the maximum safe operating speed of the engine. Over-speeding the engine is dangerous and will cause damage to the engine and to other moving parts of the machine.
 9. Check the vacuum bag frequently for wear. Replace if worn or damaged.
 10. Keep vacuum bag free of debris when not in use.

**OWNER'S
MANUAL**



SAFETY LABEL

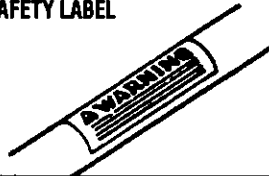

WARNING — YOUR RESPONSIBILITY

Restrict the use of this power machine to persons who read, understand and follow the warnings and instructions in this manual and on the machine.

ASSEMBLY INSTRUCTIONS

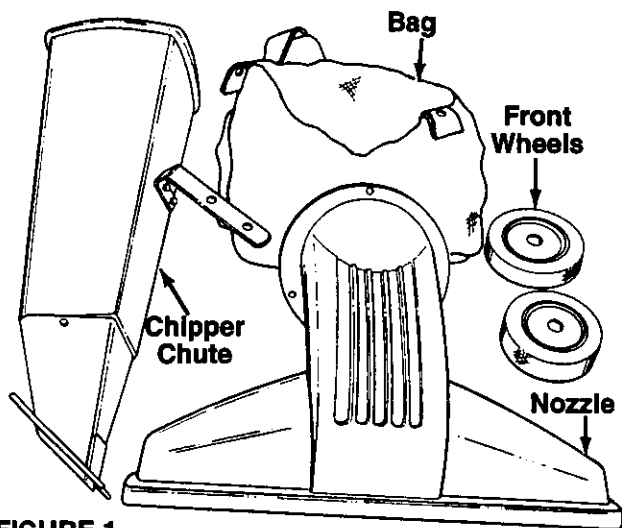

FIGURE 1.

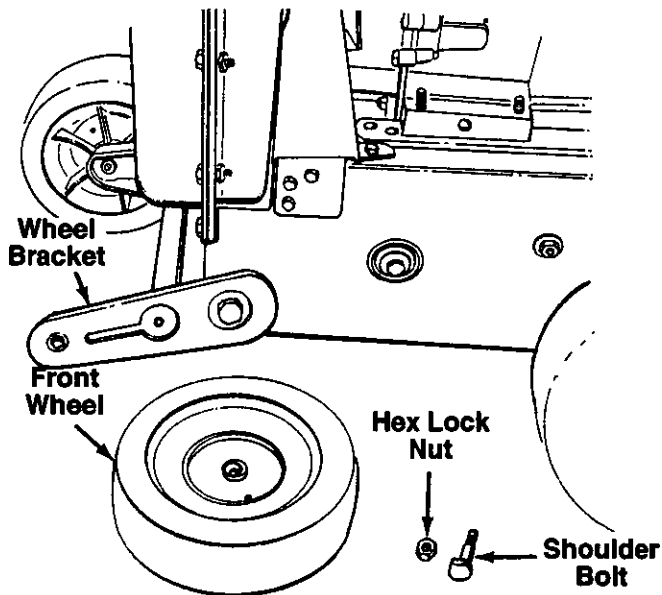

FIGURE 2.

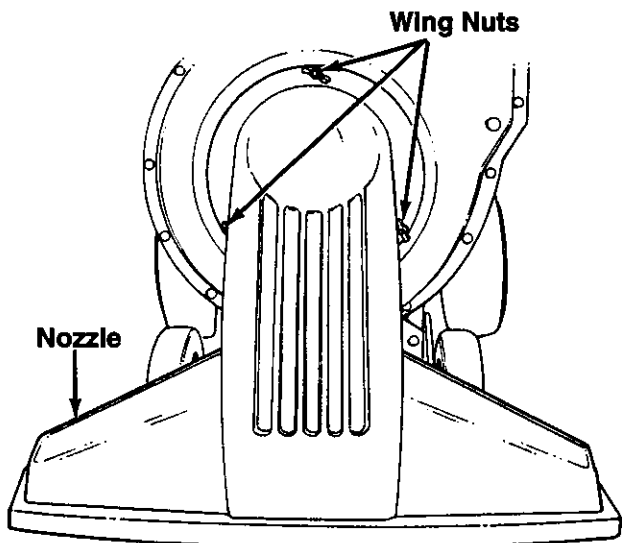

FIGURE 3.

IMPORTANT: This unit is shipped **WITHOUT GASOLINE** or **OIL**. After assembly, service engine with gasoline and oil as instructed in the separate engine manual packed with your unit.

NOTE: Reference to right or left hand side of the chipper-vacuum is observed from behind the unit in the operating position.

UNPACKING

Remove the chipper-vacuum, loose parts and literature from the carton. Make certain all parts and literature have been removed before the carton is discarded.

LOOSE PARTS IN CARTON

- ← (See Figure 1)
- (2) Front Wheels
 - (2) Hub Caps (Not Shown)
 - (1) Nozzle
 - (1) Chipper Chute
 - (1) Bag
 - (1) Shift Knob

ATTACHING THE FRONT WHEELS

- ←
1. Remove the hex lock nuts and shoulder bolts from the front of the wheel brackets. See figure 2.
 2. Place shoulder bolt through wheel and wheel bracket. Secure with hex lock nut.
 3. Attach hub caps to wheels by placing in position against the inner hub of the wheel. Press firmly around the center portion of hub cap in a circular motion, similar to installing a lid on a round, plastic container. The hub caps are flexible and will snap over the wheel hubs.

NOTE: It may be helpful to place the hub caps in hot tap water for several minutes to make them pliable before installing, especially if the temperature is less than 60°F.

← ATTACHING THE NOZZLE (See figure 3)

Remove the three plastic wing nuts from the front of the chipper-vacuum. Place the nozzle in position over the three weld studs. Secure with the wing nuts just removed.

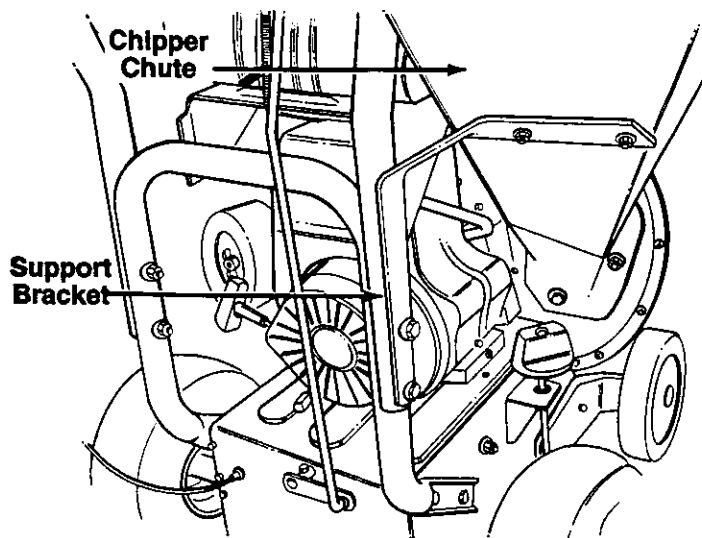

FIGURE 4.

ATTACHING THE CHIPPER CHUTE (See figure 4)

1. Remove two hex lock nuts, saddle washers and 2" long hex bolts which secure the right side of the upper handle to the lower handle.
- ← 2. Remove three cupped washers and 5/16" hex nuts from the weld studs beside the opening on the right side of the chipper-vacuum.
3. Place the chipper chute in position over the weld studs, lining up the holes in the support bracket with the holes in the right side of the handle.
4. Secure support bracket to the upper and lower handle, using hardware removed in step 1. Do not tighten.
5. Secure the base of the chipper chute to the housing, using hardware removed in step 2. Tighten securely.
6. Tighten the hardware which holds the support bracket to the upper and lower handle securely.

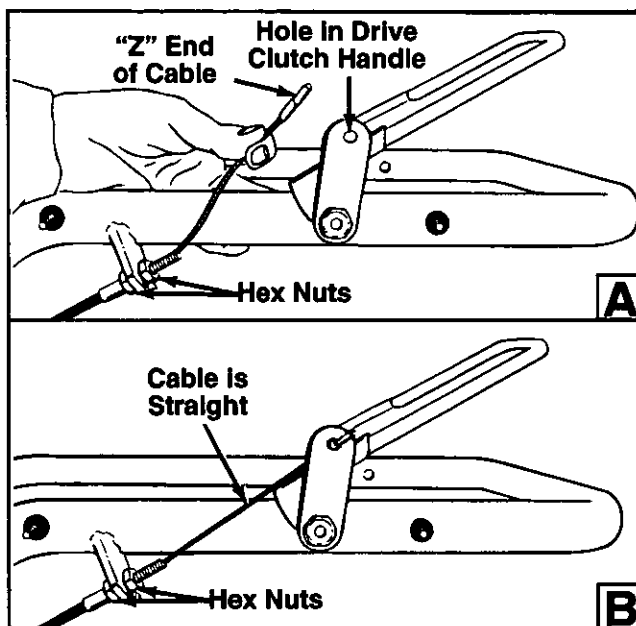

FIGURE 5.

ATTACHING THE CLUTCH CABLE

The clutch cable has been assembled at the factory. Loosen the hex nuts at the cable bracket. Hook the "Z" end of the cable into the drive clutch handle from the inside to the outside as shown in figure 5A.

← Adjust the hex nuts at the cable bracket so there is no slack in the cable, but the **cable is NOT tight. Do not overtighten the cable.** See figure 5B.

ATTACHING THE BAG

Place the four straps on the top of the bag over the upper handle, hooking them on the weld studs. See figure 6. Slip the opening on the bag over the air duct assembly. Be certain the bag is placed over the flanges on the air duct assembly. Squeeze the clamp on the drawstring, and pull the drawstring tight.

← Release the clamp.

INSTALLING THE SHIFT KNOB

Thread the shift knob onto the end of the shift lever.

FINAL ADJUSTMENT

To check the clutch adjustment, push chipper-vacuum backward and forward with the drive clutch handle released. It should move freely. Engage the drive clutch handle (hold against upper handle), and try to push chipper-vacuum backward and forward. The wheels should lock up.

If adjustment is necessary, move the hex nuts up or down the cable at the cable bracket as needed. See figure 5B. Tighten both hex nuts when correct adjustment is reached.

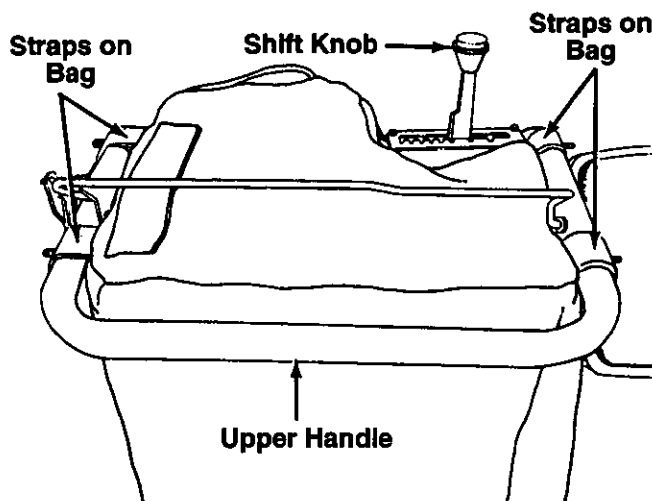

FIGURE 6.

OPERATION

CONTROLS (See figure 7)

SHIFT LEVER

The shift lever may be moved into one of eight positions. Run engine with throttle in the fast position. Use the shift lever to determine ground speed.

Forward—one of six speeds. Position number one (1) is the slowest. Position number six (6) is the fastest.

Reverse—two reverse (R) speeds. "R" (all the way to the right) is the faster of the two.

DRIVE CLUTCH HANDLE

Squeezing the drive clutch handle against the upper handle engages the wheel drive. Release the drive clutch handle to stop the forward drive.

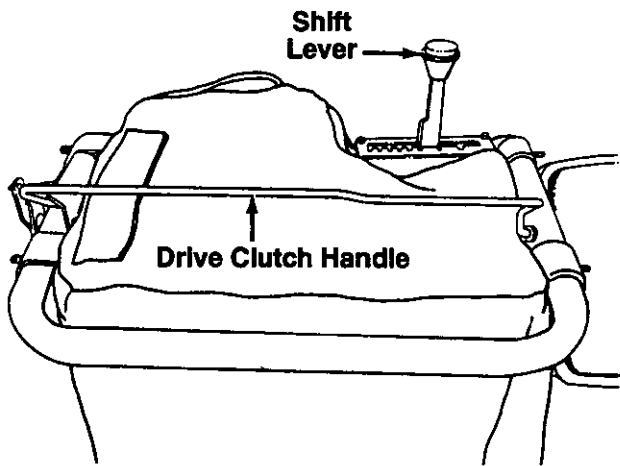

FIGURE 7.

GAS AND OIL FILL-UP

Service the engine with gasoline and oil as instructed in the separate engine manual packed with your chipper-vacuum. Read instructions carefully.

NOTE: Your chipper-vacuum is shipped without oil; however, a small amount of oil may be present from the factory. Do not overfill.



WARNING: Never fill fuel tank indoors, with engine running or while engine is hot. Do not smoke when filling fuel tank.

TO START ENGINE

IMPORTANT: If unit shows any sign of motion with the clutch handle disengaged, shut engine off immediately. Readjust as instructed in the "Final Adjustments" section of the Assembly Instructions.

1. Attach spark plug wire to spark plug.
2. Make certain drive clutch handle is in the disengaged (released) position.

3. Move choke lever on engine to CHOKE position. (A warm engine may not require choking.)
4. Move throttle control lever on engine to FAST position.
5. Grasp starter handle and pull rope out slowly until engine reaches start of compression cycle (rope will pull slightly harder at this point). Let the rope rewind slowly.
6. Pull rope with a rapid, continuous, full arm stroke. Keep a firm grip on starter handle. Let rope rewind slowly. Do not let starter handle snap back against starter.
7. Repeat instructions 5 and 6 until engine fires. When engine starts, move choke control gradually to RUN position.
8. To engage the drive mechanism, squeeze the clutch handle against the upper handle. Release the clutch handle to stop the forward motion.

TO STOP ENGINE

1. To stop engine, move throttle control lever to OFF position.
2. Disconnect spark plug wire and ground to prevent accidental starting while equipment is unattended.

IMPORTANT: The vacuum bag may have an air escape located on the upper left hand side. See figure 8. The air escape can be opened if the vacuum is operated in wet, sandy or muddy conditions.

The bag may be emptied using the large zipper as shown in figure 8. **Be certain the zipper is closed when operating the unit.**

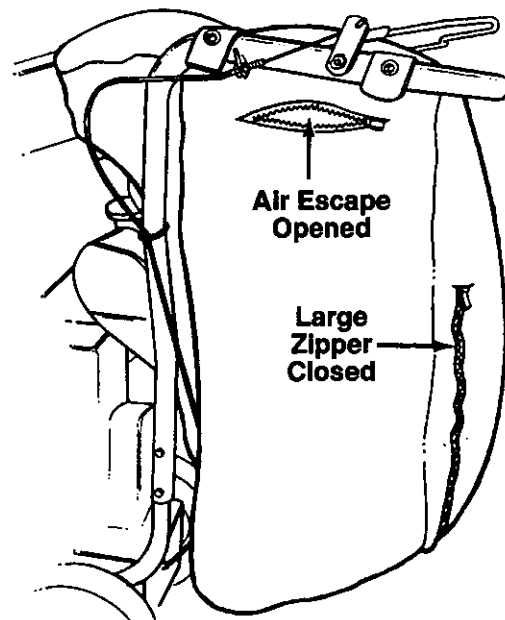

FIGURE 8.

HOW TO USE THE CHIPPER

Do not attempt to shred or chip any material other than vegetation found in a normal yard (i.e., branches, leaves, twigs, etc.). Material such as stalks or heavy branches **up to 3" in diameter** may be fed into the chipper chute. See figure 9.



WARNING: Material up to a maximum of 3" in diameter may be fed into the chipper chute. Do not attempt to shred or chip any material larger than 3" in diameter. Personal injury or damage to the machine could result.

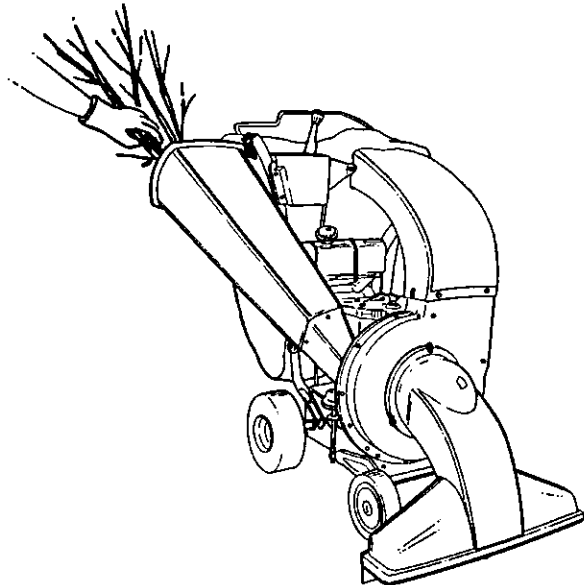

FIGURE 9.

IMPORTANT: There is a flail screen located inside the housing in the discharge area. If the flail screen becomes clogged, remove and clean as instructed in the Maintenance section on page 8.

For best performance, it is important to keep the chipper blades sharp. Refer to Maintenance section, pages 8 and 9. If the composition of the material being discharged changes (becomes stringy, etc.) or if the rate at which the material is discharged slows down considerably, it is likely that the chipper blades are dull and need to be sharpened or replaced.

ADJUSTMENTS



WARNING: Do not at any time make any adjustment to the unit without first stopping engine and disconnecting spark plug wire.

HEIGHT ADJUSTMENT

The height adjustment knob is located on the right hand side of the chipper-vacuum. See figure 10. Turn the knob clockwise to raise the nozzle. Turn the knob counterclockwise to lower.

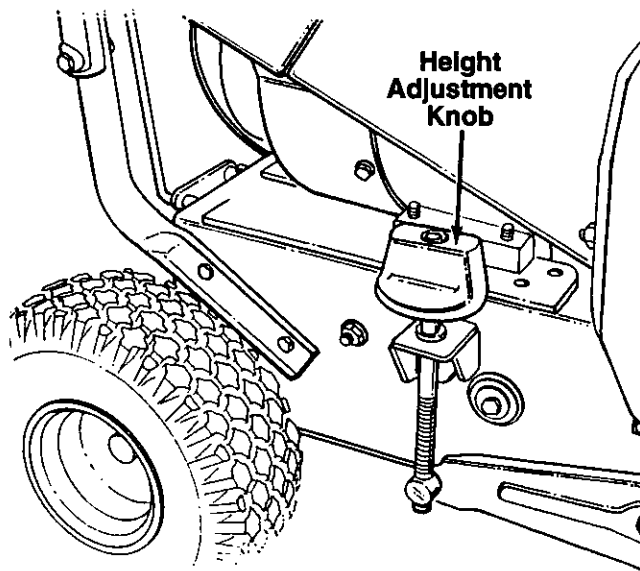

FIGURE 10.

CARBURETOR ADJUSTMENT



WARNING: If any adjustments are made to the engine while the engine is running (e.g., carburetor), keep clear of all moving parts. Be careful of heated surfaces and muffler.

Minor carburetor adjustment may be required to compensate for differences in fuel, temperature, altitude or load. Do not make unnecessary adjustments. Factory settings are satisfactory for most applications and conditions. If adjustment is needed, refer to the separate engine manual packed with your chipper-vacuum.

NOTE: A dirty air cleaner will cause engine to run rough. Be certain air cleaner is clean and attached to the carburetor before adjusting carburetor.

CLUTCH CABLE ADJUSTMENT

To adjust the clutch cable, refer to the "Final Adjustment" section of Assembly Instructions.

SHIFT ROD ADJUSTMENT

If the shift rod needs adjustment to obtain forward or reverse correctly, proceed as follows. See figure 11.

1. Remove the bag from the unit.
2. Remove the hairpin clip and flat washer from the upper end of the shift rod. Pull the ferrule out of the hole in the shift lever. (Make certain wave washer remains in place on the ferrule.)
3. Place the shift lever in 6th position (all the way to the left).
4. Push down on the shift rod. Thread the ferrule up or down the shift rod until the ferrule lines up with the upper hole in the shift lever.
5. Secure ferrule to shift lever with flat washer and hairpin clip.

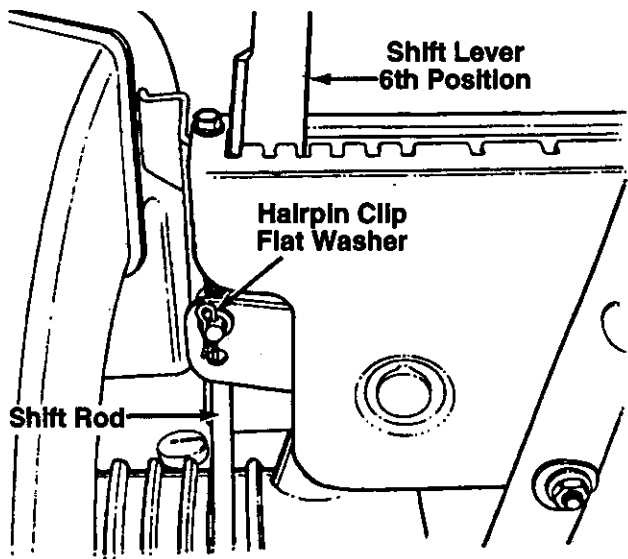

FIGURE 11.

MAINTENANCE



WARNING: Always stop engine and disconnect spark plug wire before cleaning, lubricating or performing any repairs or maintenance.

LUBRICATION

Wheels—Rear wheels are provided with light oil bearings. Place a few drops of SAE 30 oil on each bearing once a season.

ENGINE

Refer to the separate engine manual for engine maintenance instructions.

Maintain **engine oil** as instructed in the separate engine manual packed with your unit. Read and follow instructions carefully.

Service **air cleaner** every 25 hours under normal conditions. Clean every few hours under extremely dusty conditions. Poor engine performance and flooding usually indicates that the air cleaner should be serviced. To service the air cleaner, refer to the separate engine manual packed with your unit.

The **spark plug** should be cleaned and the gap reset once a season. Spark plug replacement is recommended at the start of each season; check engine manual for correct plug type and gap specifications.

Clean the engine regularly with a cloth or brush. Keep the cooling system (blower housing area) clean to permit proper air circulation which is essential to engine performance and life. Be certain to remove all dirt and combustible debris from muffler area.

REMOVING THE FLAIL SCREEN

If the discharge area becomes clogged, remove the flail screen and clean area as follows.

1. Stop the engine. Make certain the chipper-vacuum has come to a complete stop. Disconnect the spark plug wire before unclogging the discharge chute.
2. Remove the vacuum bag from the unit.
3. Remove the four self-tapping screws from the bottom of the discharge chute, and the hex bolt, flat washer and hex nut from the top. Remove the discharge chute assembly. See figure 12.

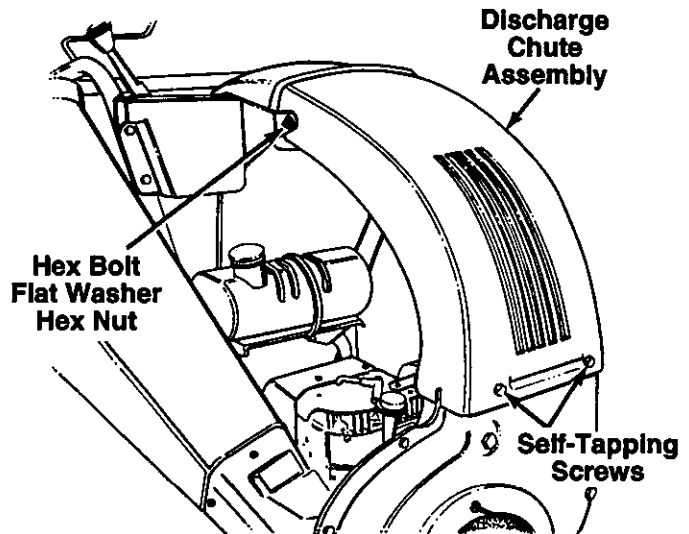

FIGURE 12.

4. Remove the two hex bolts and hex nuts which extend through the housing. Lift the flail screen from inside the housing. See figure 13.

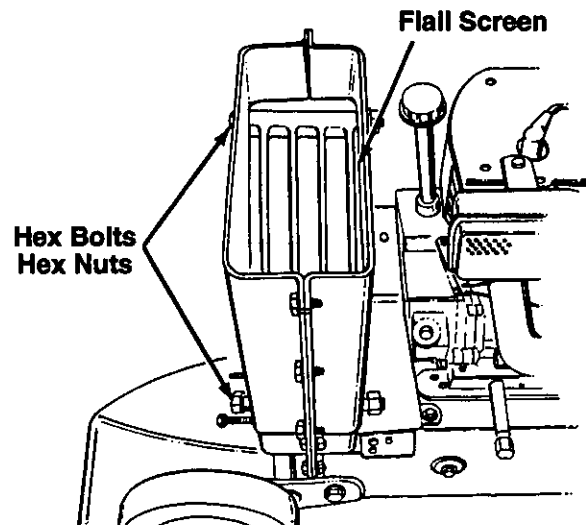

FIGURE 13.

5. Clean the screen by scraping or washing with water. Reinstall the screen.

NOTE: Be certain to reassemble the flail screen with the curved side down as shown in figure 13.

SHARPENING OR REPLACING CHIPPER BLADES

1. Disconnect the spark plug wire and move away from the spark plug.
2. Remove the flail screen as instructed in the previous section.
3. Remove the plastic belt cover on the front of the engine by removing the two self-tapping screws. See figure 14.

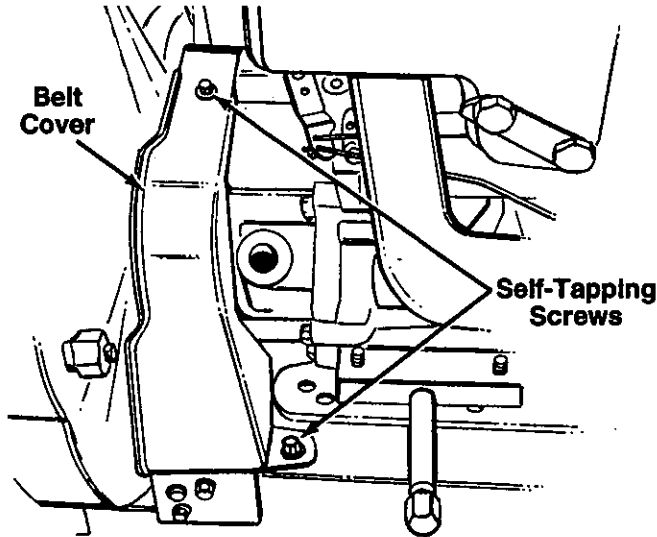

FIGURE 14.

4. Remove the access plate by removing two hex lock nuts. See figure 15.

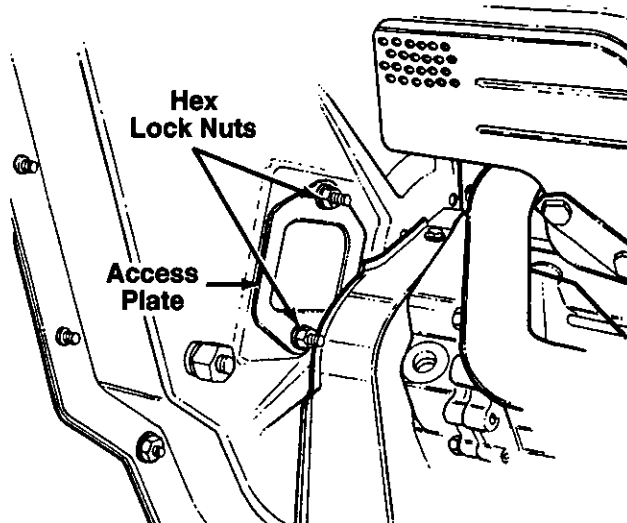

FIGURE 15.

5. Locate one of the chipper blades in the access plate opening by rotating the impeller assembly by hand. Remove the blade using a 3/16" allen wrench on the outside of the blade and 1/2" wrench on the impeller assembly, inside the housing.

6. Remove the other blade in the same manner. Replace or sharpen blades. If sharpening, make certain to remove an equal amount from each blade. Reassemble in reverse order.

NOTE: Make certain blades are reassembled with the sharp edge facing upward, as viewed from the access plate opening.

CHANGING THE FRICTION WHEEL RUBBER

The rubber on the friction wheel is subject to wear and should be checked after 50 hours of operation, and periodically thereafter. Replace friction wheel rubber if any signs of wear or cracking are found.

1. Drain the gasoline and oil from the chipper-vacuum.
2. Tip the unit backward so it rests on the handles.
3. Remove the frame cover by removing eight self-tapping screws from underneath the chipper-vacuum. See figure 16.
4. Remove the gear shaft from the unit by removing the hex bolts, lock washers and flat washers from each side of the frame. See figure 17. Hold the friction wheel assembly, and slide the gear shaft out of the unit toward the right side.
5. Remove the six screws from the friction wheel assembly (three from each side). Remove the friction wheel rubber from between the friction wheel plate.
6. Reassemble new friction wheel rubber to the friction wheel assembly, tightening the six screws in rotation and with equal force.
7. Slide the friction wheel assembly up onto the shift mechanism, then slide the gear shaft back into the unit. Reassemble in reverse order.
8. Readjust the clutch cable. Refer to adjustment section.

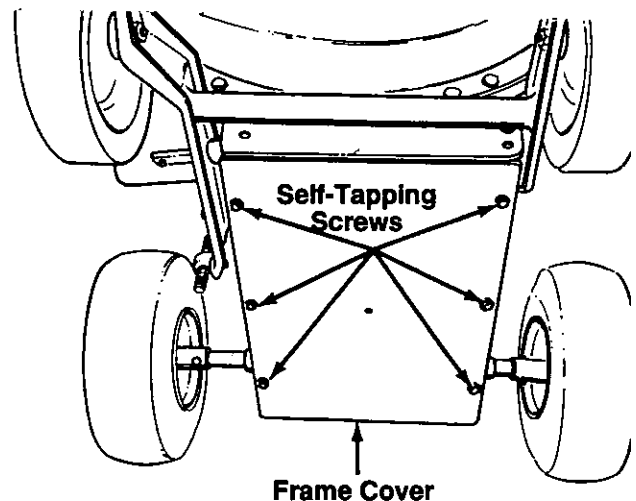

FIGURE 16.

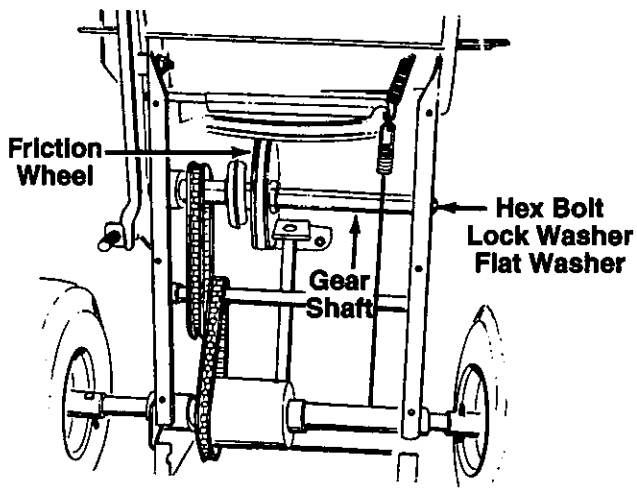

FIGURE 17.

BELT REMOVAL AND REPLACEMENT



WARNING: Disconnect the spark plug wire and move away from the spark plug.

1. Remove the plastic belt cover on the front of the engine by removing two self-tapping screws. Refer to figure 13.
2. Drain the gasoline and oil from the chipper-vacuum.
3. Tip the unit backward so that it rests on the handles.
4. Remove the frame cover by removing eight self-tapping screws from underneath the chipper-vacuum. Refer to figure 16.
5. Remove the idler pulley bracket as follows. (See figure 18.)
 - a. Take the tension off the belt by pivoting the idler pulley toward you, and line up the holes in the idler bracket assembly. Insert a nail or similar object through the holes to hold the idler pulley in this position.
 - b. Remove three self-tapping screws, and lift off the idler bracket assembly.

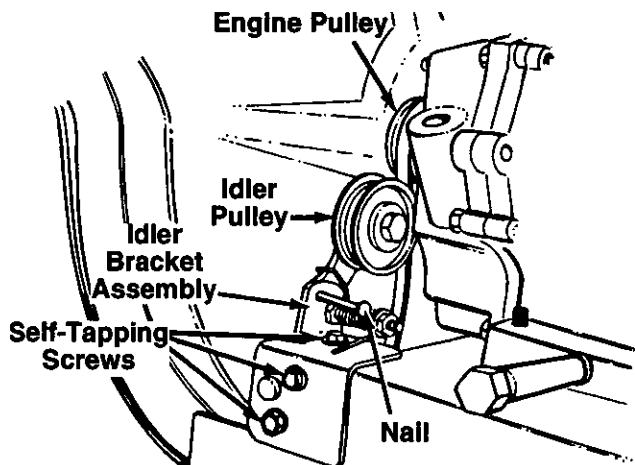

FIGURE 18.

6. Remove the hex bolt and lock washer from the engine pulley. See figure 18. Slip the engine pulley off the engine shaft, and remove the belt from the pulley.
7. Loosen the nut on the stop bolt until there is clearance between the support bracket and the friction wheel disc. See figure 19.
8. Slip the belt between the friction wheel and friction wheel disc. Remove and replace belt. Reassemble following instruction in reverse order.

NOTE: The support bracket must rest on the stop bolt after the new belt has been assembled.

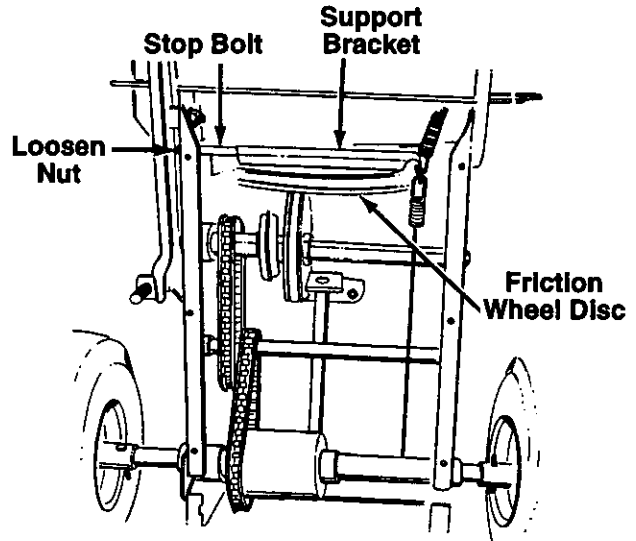

FIGURE 19.

OFF-SEASON STORAGE

The following steps should be taken to prepare your chipper-vacuum for storage.

1. Remove all dirt from exterior of engine and equipment.
2. Refer to engine manual for correct engine storage instructions.
3. If storing in an unventilated or metal storage shed, coat metal parts with a light oil or silicone to prevent rust.
4. Store in a dry, clean area. Do not store next to corrosive materials, such as fertilizer.

OPTIONAL EQUIPMENT

Hose Attachment Kit Model 290-005-000 is available as optional equipment.

TROUBLE SHOOTING

PROBLEM	POSSIBLE CAUSE(S)	CORRECTIVE ACTION
Engine fails to start	<ol style="list-style-type: none"> 1. Spark plug wire disconnected. 2. Fuel tank empty, or stale fuel. 3. Fuel shut-off valve closed (if so equipped). 4. Faulty spark plug. 	<ol style="list-style-type: none"> 1. Connect wire to spark plug. 2. Fill tank with clean, fresh fuel. 3. Open fuel shut-off valve. 4. Clean, adjust gap or replace.
Loss of power; operation erratic	<ol style="list-style-type: none"> 1. Spark plug wire loose. 2. Unit running on CHOKE. 3. Blocked fuel line or stale fuel. 4. Water or dirt in fuel system. 5. Carburetor out of adjustment. 6. Dirty air cleaner. 	<ol style="list-style-type: none"> 1. Connect and tighten spark plug wire. 2. Move choke lever to OFF position. 3. Clean fuel line; fill tank with clean fresh gasoline. 4. Disconnect fuel line at carburetor to drain fuel tank. Refill with fresh fuel. 5. Adjust carburetor.† 6. Service air cleaner.†
Engine overheats	<ol style="list-style-type: none"> 1. Carburetor not adjusted properly. 2. Engine oil level low. 	<ol style="list-style-type: none"> 1. Adjust carburetor.† 2. Fill crankcase with proper oil.
Too much vibration	Loose parts or damaged impeller.	Stop engine immediately and disconnect spark plug wire. Tighten all bolts and nuts. Make all necessary repairs. If vibration continues, have unit serviced by an authorized service dealer.
Unit does not discharge	<ol style="list-style-type: none"> 1. Discharge chute clogged. 2. Foreign object lodged in impeller. 3. Vacuum bag is full. 	<ol style="list-style-type: none"> 1. Stop engine immediately and disconnect spark plug wire. Clean flail screen and inside of housing. See Maintenance section of this manual. 2. Stop engine immediately and disconnect spark plug wire. Remove lodged object. 3. Empty bag.
Rate of discharge slows considerably or composition of discharged material changes	Chipper blades dull.	Sharpen or replace chipper blades.

†Refer to the engine manual packed with your unit.

NOTE: For repairs beyond the minor adjustments listed above, please contact your nearest authorized service dealer.

Model 315B

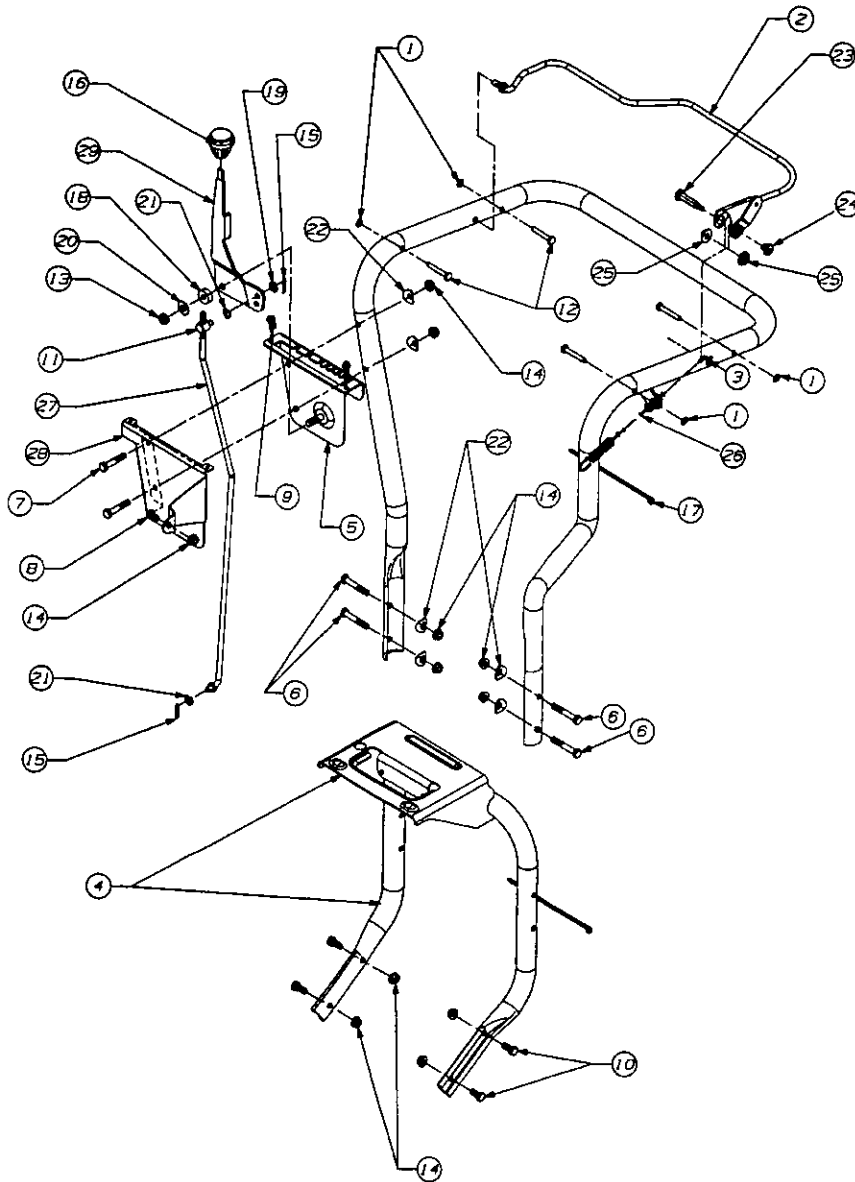

REF. NO.	PART NO.	DESCRIPTION	QTY.	REF. NO.	PART NO.	DESCRIPTION	QTY.
1	1539-019	PUSHNUT	4	16	720-0232	KNOB-SHIFT	1
2	647-0019	CONTROL ASSY	1	17	725-0157	CABLE TIE	2
3	649-0008	HANDLE ASSY-UPPER	1	18	735-0126	WASHER-RUBBER	1
4	649-0012	HANDLE ASSY-LOWER	1	19	736-0264	WASHER-FLAT	1
5	681-0076	BRACKET ASSY-SHIFT	1	20	736-0300	WASHER-FLAT	1
6	710-0116	SCREW-HEX	4	21	736-0413	WASHER-SPRING	2
7	710-0380	SCREW-HEX	2	22	736-0451	WASHER-SADDLE	6
8	710-0621	SCREW-HEX	1	23	738-0560	SCREW-SHOULDER	1
9	710-0896	SCREW-HEX	2	24	738-0561	NUT-SHOULDER	1
10	710-3008	SCREW-HEX	4	25	741-0402	BEARING-FLANGE PLASTIC	2
11	711-0677	FERRULE	1	26	746-0921	CABLE-CLUTCH	1
12	711-0737	PIN-STUD	4	27	747-0626	ROD-SHIFT	1
13	712-0116	NUT-HEX LOCK	1	28	781-0626	COVER-SHIFT	1
14	712-3004A	NUT-HEX LOCK	11	29	784-0297	HANDLE-SHIFT	1
15	714-0104	PIN-COTTER	2				

COLOR CODES: 788-0637—BLACK 788-0662—OYSTER GRAY

Model 315B

REF. NO.	PART NO.	DESCRIPTION	QTY.
1	681-0059	HOUSING ASSY—INNER	1
2	681-0060	HOUSING ASSY—OUTER	1
3	710-0382	SCREW-HEX	2
4	710-0607	SCREW-HEX SELF TAP	18
5	710-0772	SCREW-HEX	2
6	710-3008	SCREW-HEX	2
7	712-0384	NUT-HEX LOCK	2
8	712-0421	KNOB	3
9	712-3004A	NUT-HEX LOCK	4
10	712-3010	NUT-HEX (GR 5)	3
11	719-0326	SCREEN	1
12	736-0119	WASHER-LOCK	3
13	736-0242	WASHER-BELL	3
14	781-0598	BLADE-FLAIL HOUSING	1
15	781-0599	BLADE-FLAIL HOUSING	1
16	781-0627	COVER-CHIPPER	1

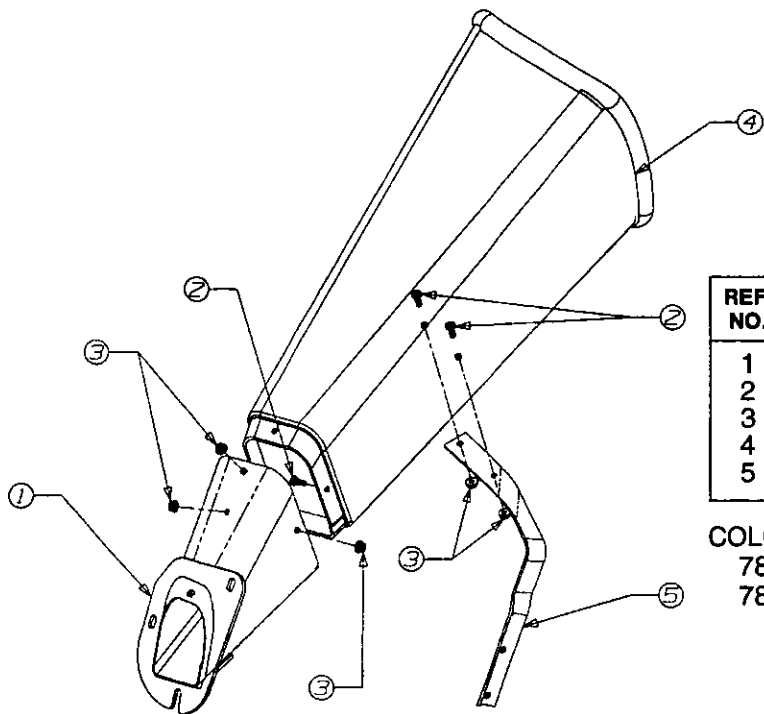
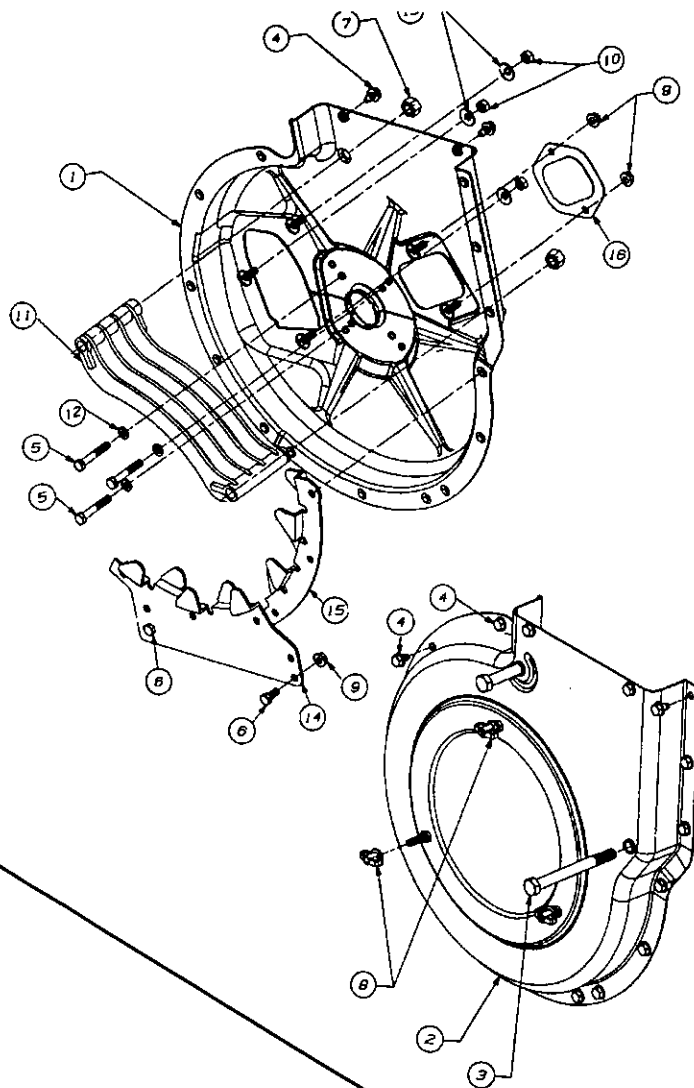

REF. NO.	PART NO.	DESCRIPTION	QTY.
1	681-0068	CHUTE ASSEMBLY	1
2	710-0258	SCREW HEX	5
3	712-3027	NUT-LOCK	5
4	731-1609	CHUTE -CHIPPER UPPER	1
5	781-0625	BRACKET SUPPORT	1

COLOR CODES:
 788-0637 BLACK
 788-0662 OYSTER GRAY

Model 315B

REF. NO.	PART NO.	DESCRIPTION	QTY.
1	681-0078	IMPELLER ASSY COMP. (INCL. REF. NOS. 2 THRU 12)	1
2	710-1273	SCREW-HEX	1
3	736-0217	WASHER-LOCK	1
4	736-0247	WASHER-FLAT	1
5	681-0078	IMPELLER ASSY	1
6	711-0833A	PIN-CLEVIS	3
7	710-1054	SCREW-FLAT HEAD	4
8	712-0411	NUT-HEX LOCK	4
9	715-0249	PIN-ROLL SPRING	3
10	719-0329	BLADE-FLAIL	3
11	736-0119	WASHER-LOCK	4
12	742-0544	BLADE-CHIPPER	4

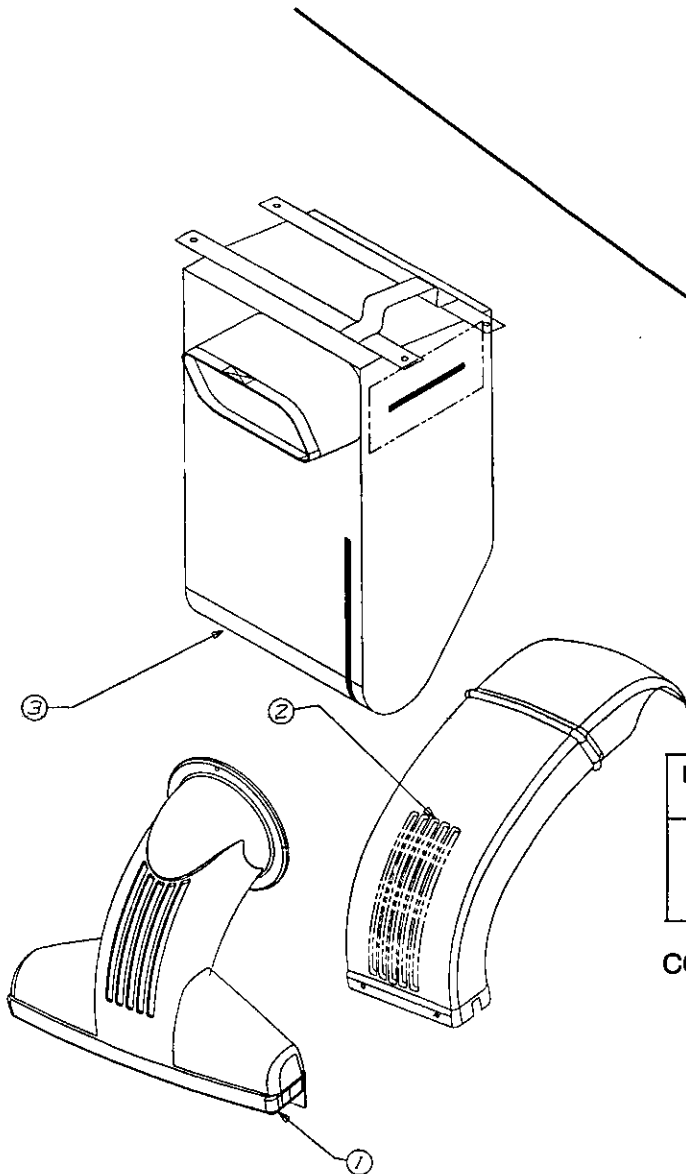
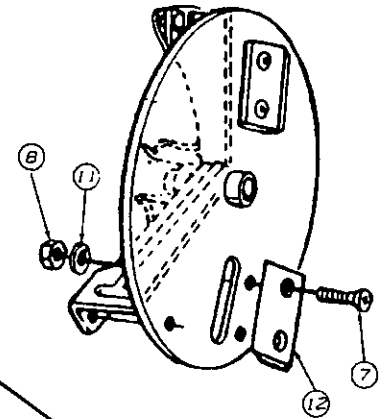
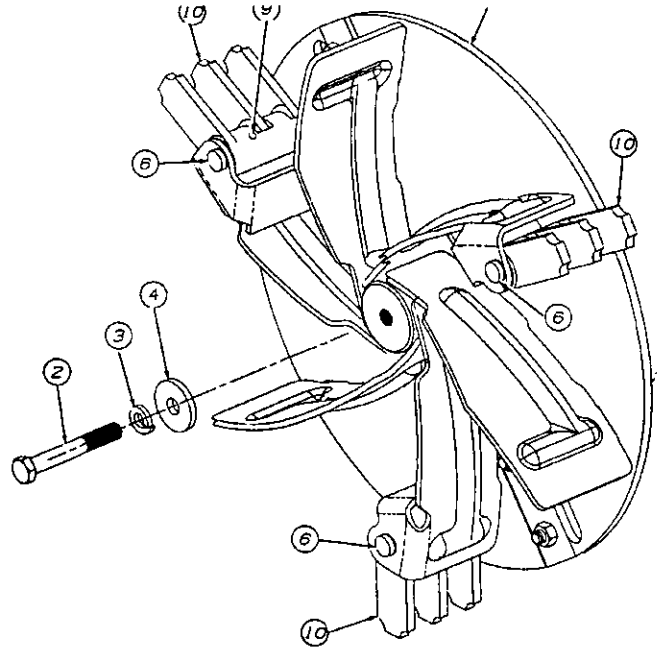

REF. NO.	PART NO.	DESCRIPTION	QTY.
1	631-0028	NOZZLE ASSY-VACUUM	1
2	731-1573	CHUTE-DISCHARGE	1
3	764-0472	BAG-VACUUM	1

COLOR CODES:
 788-0637 BLACK
 788-0662 OYSTER GRAY

Model 315B

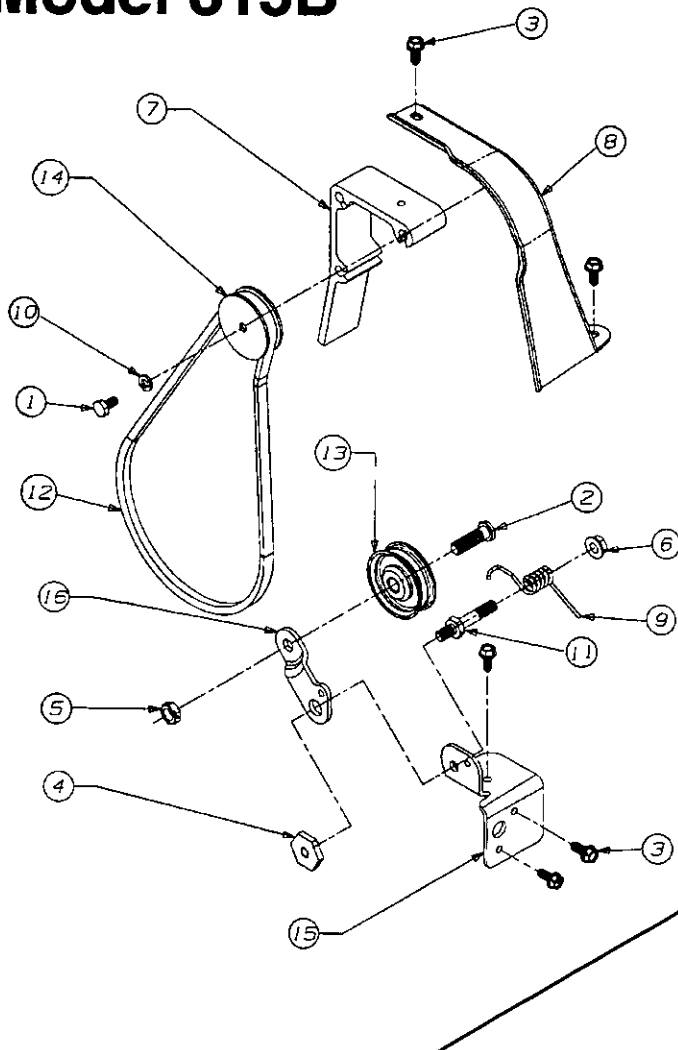

REF. NO.	PART NO.	DESCRIPTION	QTY.
1	710-0230	SCREW-HEX	1
2	710-0723	SCREW-HEX	1
3	710-0896	SCREW-HEX	5
4	711-0758	NUT-HEX SHOULDER	1
5	712-0266	NUT-HEX LOCK	1
6	712-3004A	NUT-HEX LOCK FLANGE	1
7	719-0330	ADAPTER-MOUNTING	1
8	731-1584	COVER-BELT	1
9	732-0745	SPRING-TORSION	1
10	736-0329	WASHER-LOCK	1
11	738-0908	BOLT-IDLER	1
12	754-0256	V-BELT	1
13	756-0313	IDLER-FLAT	1
14	756-0649	PULLEY	1
15	781-0611	BRACKET-IDLER PIVOT	1
16	781-0614	BRACKET-IDLER	1

COLOR CODES:
 788-0637 BLACK
 788-0662 OYSTER GRAY

REF. NO.	PART NO.	DESCRIPTION	QTY.
1	681-0070	BRKT ASSY—WHEEL PIVOT	1
2	710-0520	SCREW-HEX	1
3	710-0924	SCREW-MACHINE PAN HD	1
4	710-3008	SCREW-HEX	2
5	711-1041	FERRULE—ADJUSTABLE	1
6	712-3004A	NUT-HEX FLANGE	2
7	712-3005	NUT-HEX FLANGE LOCK	2
8	714-0115	PIN-COTTER	1
9	716-0104	RING-E	1
10	720-0236	KNOB-PLASTIC	1
11	736-0270	WASHER-BELL	1
12	736-0300	WASHER-FLAT	2
13	736-0369	WASHER-FLAT	2
14	738-0258	SCREW-SHOULDER	1
15	747-0631	ROD-ADJUSTABLE	1
16	750-0985	SPACER	1
17	781-0605	BRACKET-HEIGHT ADJ	1

COLOR CODES:
 788-0637 BLACK
 788-0662 OYSTER GRAY

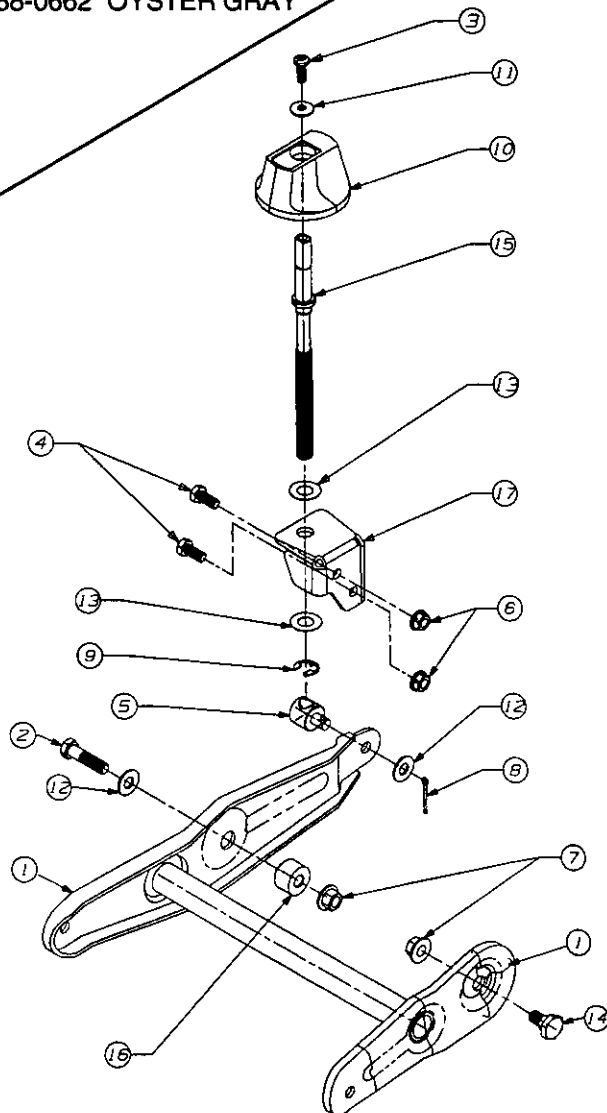

Model 315B

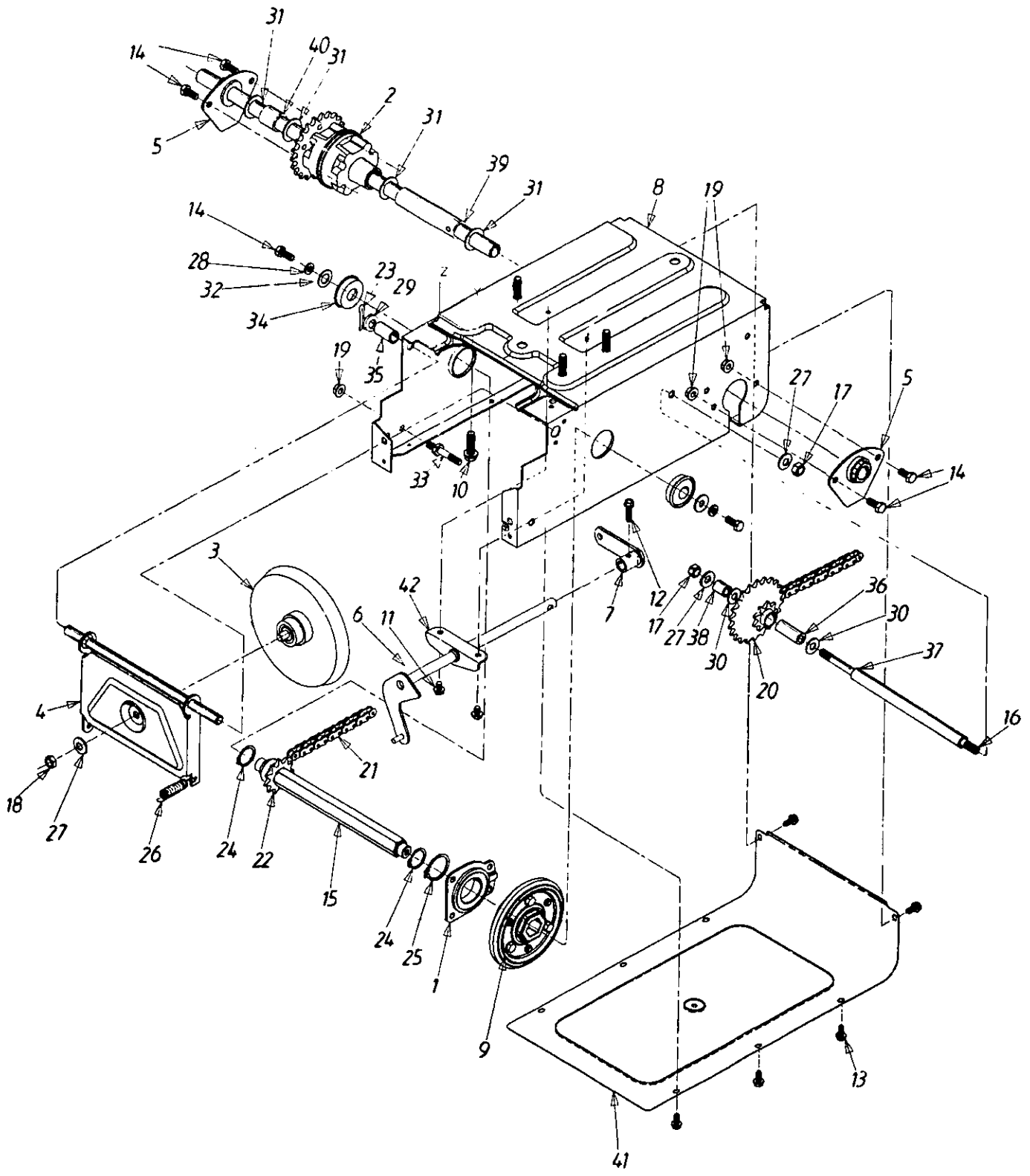

Model 315B

REF. NO.	PART NO.	DESCRIPTION	QTY.	REF. NO.	PART NO.	DESCRIPTION	QTY.
1	618-0063	BEARING ASSY-FRICTION WHEEL	1	20	713-0330	SPROCKET & HUB	1
2	618-0168	DIFFERENTIAL ASSY COMP.	1	21	713-0374	CHAIN	1
3	656-0009	DISC-FRICTION WHEEL ASSY COMP.	1	22	713-0415	SPROCKET 11T	1
	756-0564	DISC-FRICTION WHEEL		23	714-0474	PIN-COTTER	1
	738-0865	BOLT-SHOULDER		24	716-0102	RING-SNAP	2
	741-0600	BEARING-BALL		25	716-0185	RING-SNAP	1
4	681-0055	BRACKET ASSY-SUPPORT	1	26	732-0264	SPRING-EXTENSION	1
5	681-0058	BRACKET ASSY-AXLE	2	27	736-0105	WASHER-BELL	3
6	681-0069	SHAFT ASSY-SHIFT	1	28	736-0119	WASHER-LOCK	2
7	681-0072	ARM ASSY-SHIFT	1	29	736-0160	WASHER-FLAT	1
8	681-0073	FRAME ASSY	1	30	736-0267	WASHER-FLAT	2
9	684-0042	WHEEL ASSY-FRICTION	1	31	736-0287	WASHER-FLAT	4
10	710-0502A	SCREW-HEX SELF-TAP	4	32	736-3089	WASHER-FLAT	2
11	710-0653	SCREW-HEX WASHER	2	33	738-0908	BOLT-IDLER	1
12	710-0788	SCREW-HEX WASHER	1	34	741-0563	BEARING-BALL	2
13	710-0896	SCREW-HEX	8	35	748-0382	SPACER	1
14	710-3008	SCREW-HEX	6	36	750-0351	SLEEVE	1
15	711-1026	SHAFT-HEX	1	37	750-0978	SPACER	1
16	711-1028	SHAFT-JACK	1	38	750-0979	SPACER	1
17	712-0241	NUT-HEX	2	39	750-0980	SPACER	1
18	712-0711	NUT-HEX JAM	1	40	750-0981	SPACER	1
19	712-3004A	NUT-HEX FLANGE LOCK	5	41	781-0612	COVER-FRAME	1
				42	784-5590	BRACKET-SHIFT	1

COLOR CODES:

788-0637 BLACK

788-0662 OYSTER GRAY

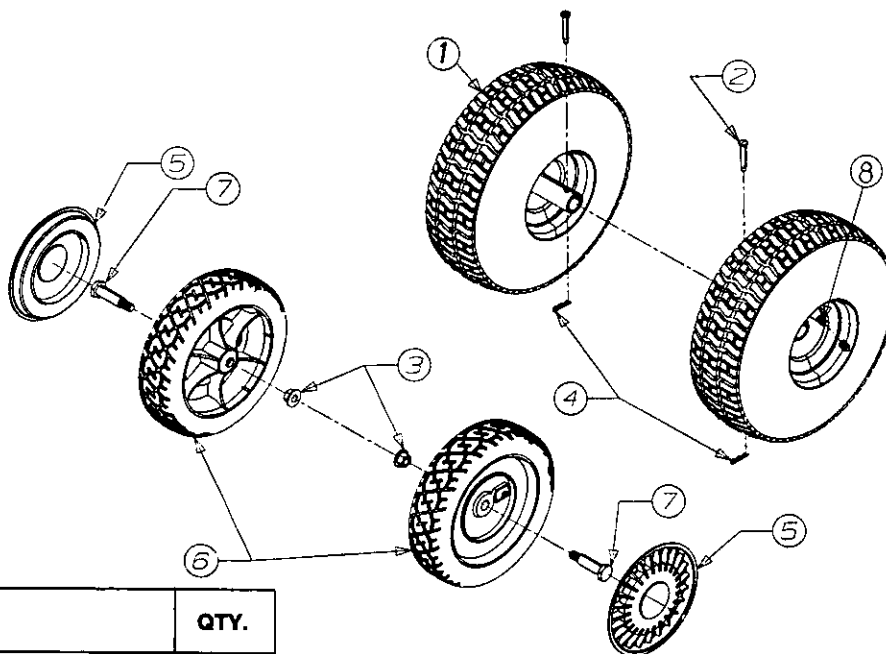

REF. NO.	PART NO.	DESCRIPTION	QTY.
1	634-0100	WHEEL ASSY COMPLETE 4" X 10"	2
	634-0101	RIM ASSY COMPLETE	2
	734-1598	TIRE PNEUMATIC 4" X 10"	2
2	711-1017	PIN-CLEVIS	2
3	712-3005	NUT-HEX FLANGE	2
4	714-0104	PIN-COTTER	2
5	731-0981A	HUB CAP	2
6	734-1793	WHEEL 2" X 8"	2
7	738-0213	SCREW-SHOULDER	2
8	734-0255	VALVE STEM	2

Model 315B

REF. NO.	PART NO.	DESCRIPTION	QTY.
1	618-0168	DIFFERENTIAL ASSY COMPLETE	1
2	710-1206	SCREW-HEX	4
3	711-1035	SHAFT-CROSS	1
4	711-1037	AXLE-SHAFT 10.95" LONG	1
5	711-1038	AXLE-SHAFT 9.82" LONG	1
6	713-0445	SPROCKET 22 T	1
7	716-0232	RING-RETAINING (2 PER AXLE)	4
8	717-1358	GEAR-DIFFERENTIAL 14T	2
9	717-1437	GEAR-DIFFERENTIAL 10T	2
10	719-0333	HOUSING-DIFFERENTIAL RH	1
11	719-0334	HOUSING-DIFFERENTIAL LH	1
12	748-0383	BEARING-FLANGE	2
13	737-0300	GREASE	1 OZ
14	—	SEALANT-LOCTITE 5699	

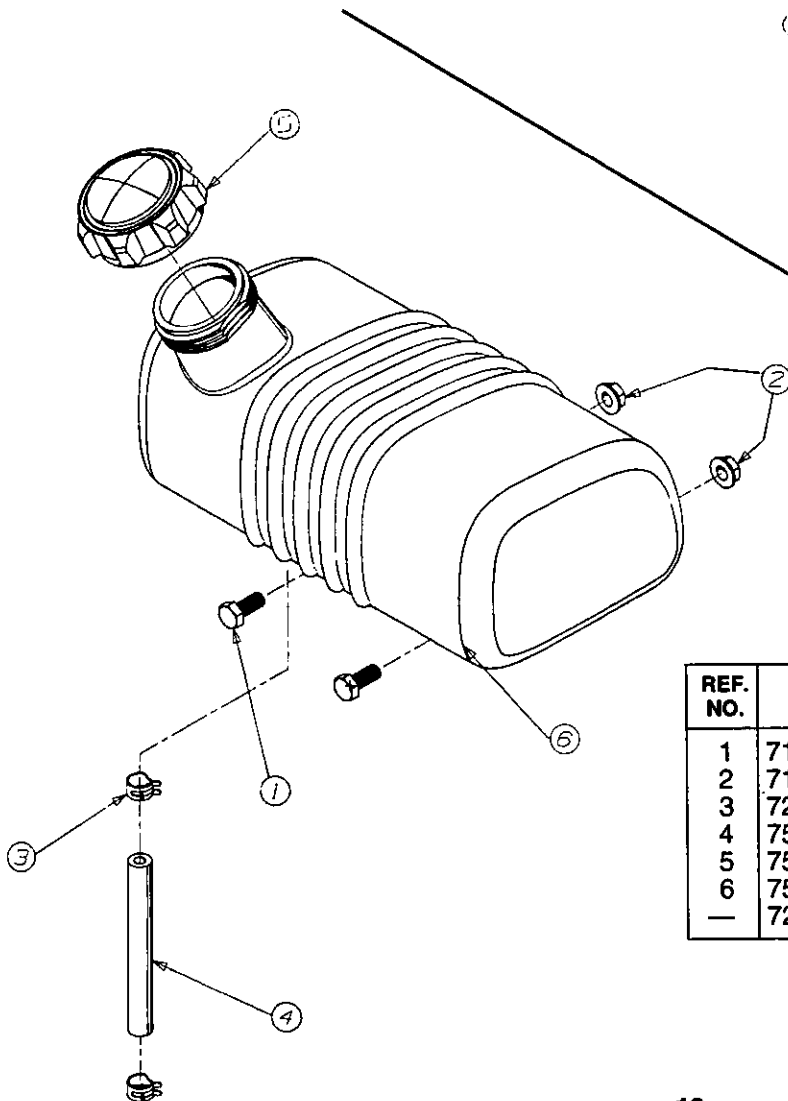
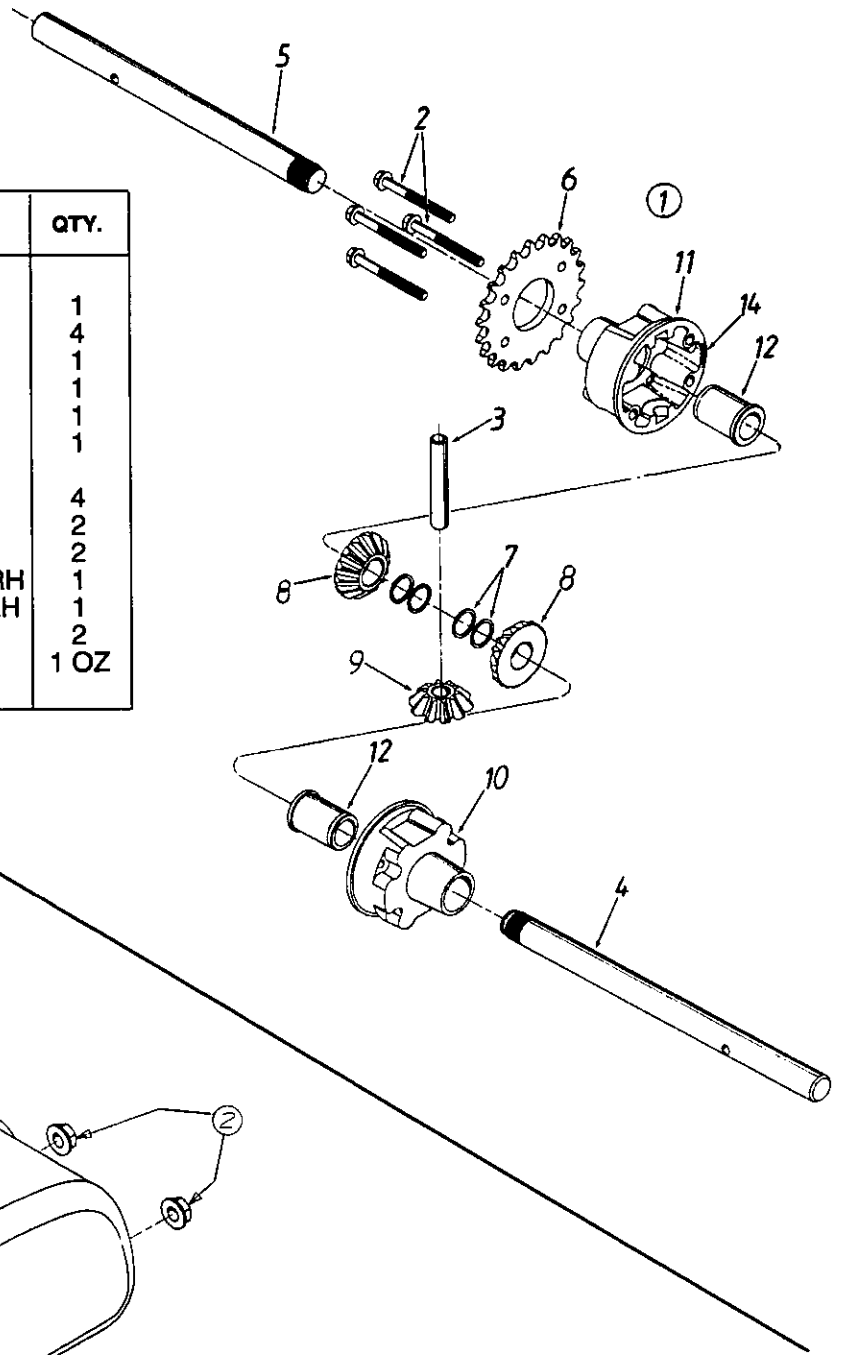

REF. NO.	PART NO.	DESCRIPTION	QTY.
1	710-3008	SCREW-HEX	2
2	712-3004A	NUT-HEX LOCK FLANGE	2
3	726-0205	CLAMP-HOSE	2
4	751-0535-8	HOSE-FUEL LINE 8"	1
5	751-0603	CAP-FUEL	1
6	751-0615	TANK-FUEL 1 GALLON	1
—	726-0209	CABLE TIE (NOT SHOWN)	1

**THE WHITE OUTDOOR PRODUCTS CUSTOMER CARE
TWO YEAR LIMITED WARRANTY**

For two years from the date of retail purchase within the United States of America, its possessions and territories, White Outdoor Products Company will, at its option, repair or replace, for the original purchaser free of charge, any part or parts found to be defective in material or workmanship. This warranty covers units which have been operated and maintained in accordance with the owner's instructions furnished with the unit, and which have not been subject to misuse, abuse, neglect, accident, improper maintenance or alteration.

Normal wear parts or components thereof are subject to separate terms as noted below in the "no fault ninety day consumer warranty" clause. Commercial use is subject to the terms listed above, and is covered for a period of 90 days from the date of purchase.

TWO YEAR CONSUMER WARRANTY ON NORMAL WEAR PARTS WITH NINETY DAY NO FAULT PROTECTION. All normal wear part failures will be covered on this product for a period of ninety days regardless of cause. After ninety days but within the two year warranty period, normal wear parts failures will be covered if caused by defects in material or workmanship. Normal wear parts are defined as belts, blades, blade adapters, grass bags, rider deck wheels, seats, snowblower skid shoes, shave plates and tires.

HOW TO OBTAIN SERVICE: Warranty service is available, with proof of purchase, through your local authorized service dealer. To locate the dealer in your area, please check the Yellow Pages or contact the customer service department of White Outdoor Products Company, PO Box 361131, Cleveland, Ohio 44136-0019, phone 1-800-800-9448. The return of a complete unit will not be accepted by the factory unless prior written permission has been extended by the service department of White Outdoor Products Company.

TRANSPORTATION CHARGES: Transportation charges for the movement of any power equipment unit or attachment are the responsibility of the purchaser. Transportation charges for any parts submitted for replacement under this warranty must be paid by the purchaser unless such return is requested by White Outdoor Products Company.

UNITS EXPORTED OUT OF THE UNITED STATES: White Outdoor Products Company does not extend any warranty for products sold or exported outside of the United States of America, its possessions and territories, except those sold through White Outdoor Products.

OTHER WARRANTIES:

1. The engine or component parts thereof carry separate warranties from their manufacturers. Please refer to the applicable manufacturer's warranty on these items.
2. Log splitter pumps, valves and cylinders or component parts thereof are covered by a one year warranty.
3. Batteries are covered by a 90 day replacement warranty.
4. All other warranties, express or implied, including any implied warranty of merchantability or fitness for a particular purpose are hereby expressly disclaimed in their entirety.
5. The provisions as set forth in this warranty provide the sole and exclusive remedy of White Outdoor Products Company's obligations arising from the sales of its products. White Outdoor Products Company will not be liable for incidental or consequential loss or damage.

HOW THE STATES LAW RELATES TO THIS WARRANTY: This limited warranty gives you specific legal rights, and you may also have other rights which vary from state to state. Certain disclaimers are not allowed in some states and therefore they may not apply to you under all circumstances.

Note: This warranty does not cover set-up routine maintenance items such as lubricants, filters, blade sharpening and tune-ups, or adjustments such as brake adjustments. Nor does this warranty cover normal deterioration of the exterior finish due to use or exposure.



The Pursuit of Value...



White Shows the Way!

The only way to insure the performance of your product is to use original equipment parts and accessories. White Outdoor Products designs and engineers quality parts to exacting specifications. When you substitute, you take a chance on quality, reliability, safety and performance. Use White Outdoor Products original equipment parts—See your local White Outdoor dealer!