

# EPSON Stylus® C86

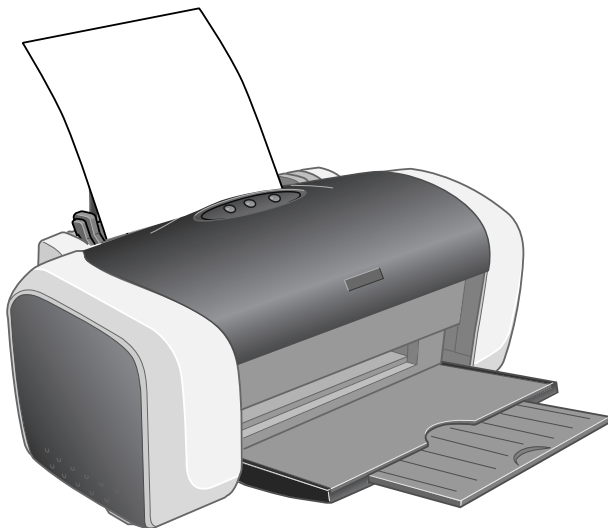

## Quick Guide

*Basic Printing*  
*Printing Photos*  
*Replacing Ink Cartridges*  
*Solving Problems*  
*Requirements and Notices*

CPD-17832  
4049262-00  
xxx

# Contents

<b>Basic Printing</b> . . . . .	<b>3</b>
Loading Paper . . . . .	<b>3</b>
Printing in Windows . . . . .	<b>4</b>
Printing with Macintosh OS X . . . . .	<b>6</b>
Printing with Macintosh OS 9 . . . . .	<b>8</b>
Installing Printer Software for Windows NT 4.x . . . . .	<b>10</b>
<b>Printing Photos</b> . . . . .	<b>11</b>
Loading Paper . . . . .	<b>11</b>
Printing Photos in Windows . . . . .	<b>13</b>
Printing Photos on Macintosh OS X . . . . .	<b>16</b>
Printing Photos on Macintosh OS 9 . . . . .	<b>18</b>
<b>Replacing Ink Cartridges</b> . . . . .	<b>21</b>
Purchasing Ink Cartridges . . . . .	<b>21</b>
Removing and Installing Ink Cartridges . . . . .	<b>23</b>
<b>Solving Problems</b> . . . . .	<b>27</b>
Checking the Printer's Lights . . . . .	<b>27</b>
Problems and Solutions . . . . .	<b>28</b>
Where To Get Help . . . . .	<b>30</b>
<b>Requirements and Notices</b> . . . . .	<b>31</b>
Windows System Requirements . . . . .	<b>31</b>
Macintosh System Requirements . . . . .	<b>31</b>
Important Safety Instructions . . . . .	<b>32</b>
FCC Compliance Statement . . . . .	<b>34</b>
Declaration of Conformity . . . . .	<b>35</b>
ENERGY STAR Compliance . . . . .	<b>35</b>
Epson America, Inc. Limited Warranty . . . . .	<b>36</b>

# Basic Printing

Before you start, make sure your printer is set up and its software is installed as described on the *Start Here* sheet. If you're using Windows NT® 4.x, see page 10 for instructions on installing the software.

---

## Loading Paper

1. Open the output tray and its extension.
2. Fan the stack of paper and place it against the right edge of the slot. Don't push the paper in.
3. Press in the side of the left edge guide and slide it against the paper (but not too tightly).

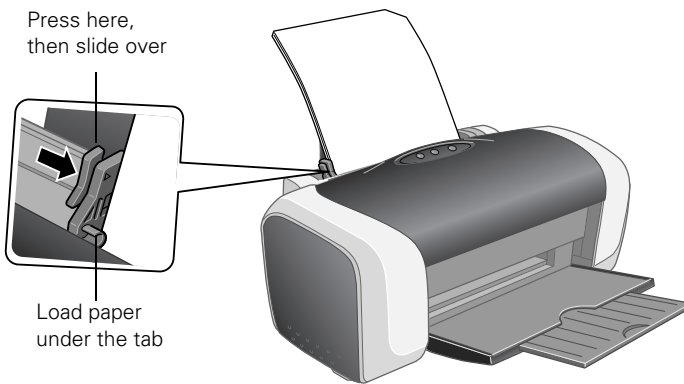

Follow these guidelines when loading paper:

- Don't load paper above the arrow on the left edge guide.
- Load the printable side face-up. It's often brighter or whiter than the other side.
- Always load the short edge first, even when printing in landscape mode.
- Load letterhead or preprinted paper into the printer top edge first.

# Printing in Windows

1. From the File menu, click **Print**. You see a Print window like this one:

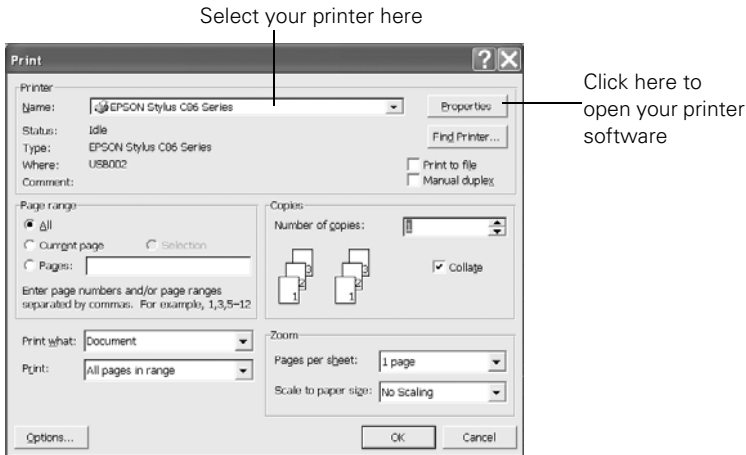

2. Make sure **Epson Stylus C86 Series** is selected.
3. Click the **Properties** or **Preferences** button. (If you see a **Setup**, **Printer**, or **Options** button, click it. Then click **Properties** or **Preferences** on the next screen.)
4. Select the following in the properties window:



5. Select from these **Quality Option** settings:



**Draft:** For rough drafts with reduced print quality



**Text:** For text-only documents with higher text quality



**Text & Image:** For documents with text and images with higher quality



**Photo:** For photos and graphics with good quality and speed



**Best Photo:** For photos or graphics with high print quality

**Note:**

For more information about printer settings, click the ? or **Help** button.

The Quality Option settings on this screen give you the best combination of quality and speed for most prints. For instructions on printing at the highest quality (Photo RPM®), see page 14.

6. Select the paper **Type** for the paper you're using.

7. Select other settings as shown on page 4, then click **OK**.

8. At the Print window, click **OK** or **Print** to start printing.

During printing, this window appears and shows the progress of your print job. You can use the buttons to cancel, pause, or resume printing. You can also see how much ink you have left.



Click to cancel printing

Click to pause or resume printing

**Tip:**

You can also cancel printing by pressing the  paper button on your printer.

# Printing with Macintosh OS X

If you're using an OS X compatible printing application, follow the steps below to print a document. (If you're using an application that's compatible only with Macintosh® Classic mode, follow the steps on page 8 instead.)

Before you begin, make sure you added your printer to the Print Center as described on the *Start Here* sheet.

1. From the File menu, choose **Page Setup** and select the following settings:

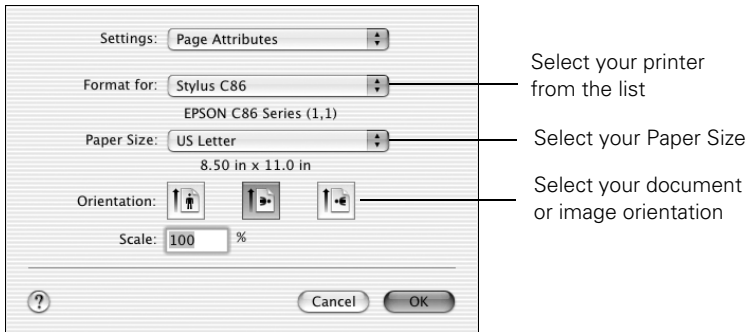

2. After you select your settings, click **OK**.
3. From the File menu select **Print**. You see a window like this one:

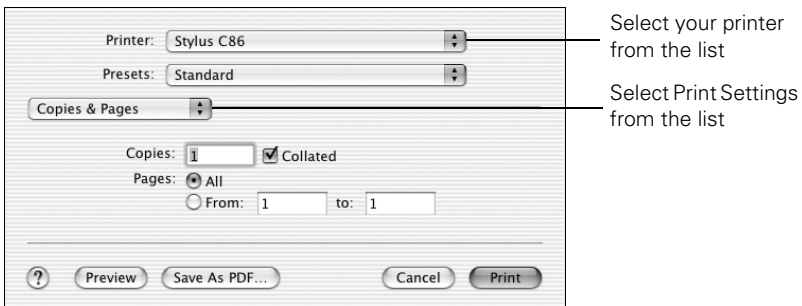

4. Open the Printer pull-down list, and select your printer again. Always check to make sure you selected the same printer you chose in the Page Setup window.
5. Select **Print Settings** from the pull-down list.

6. Select the following Print Settings as necessary:

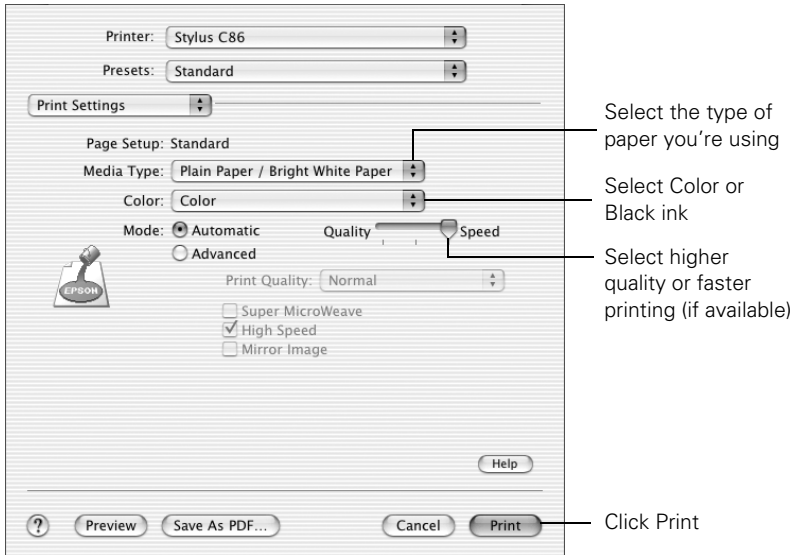

**Note:**

For more information about printer settings, click the ? or Help button.

The Quality setting on this screen gives you the best combination of quality and print speed for most prints. For instructions on printing at the highest quality (Photo RPM), see page 17.

7. Choose other settings as necessary, then click Print.
8. To monitor the progress of your job, click the  Print Center icon when it appears in the dock on the bottom of your desktop. Double-click Stylus C86 in the Printer List window.

You can click the print job, then cancel, hold, or resume printing.

**Note:**

You can also cancel printing by pressing the  Paper button on your printer.

9. When you're finished, close Print Center.

# Printing with Macintosh OS 9

Before you begin, make sure you selected your printer in the Chooser as described on the *Start Here* sheet.

1. From the File menu, select **Page Setup**. Select the following settings:

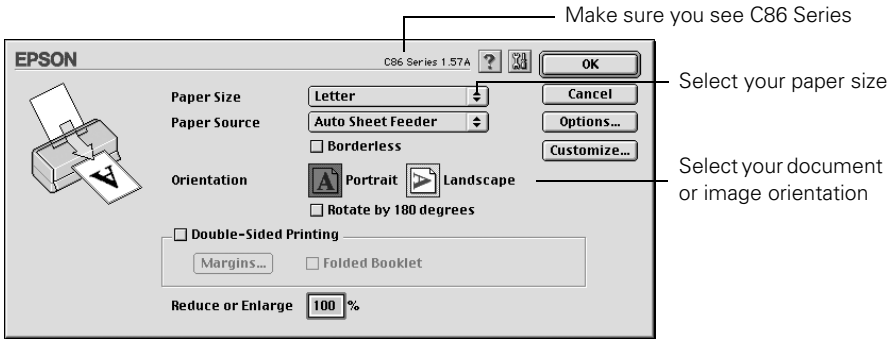

2. After you choose your settings, click **OK**.
3. From the File menu, select **Print**.
4. Select the following print settings as necessary:

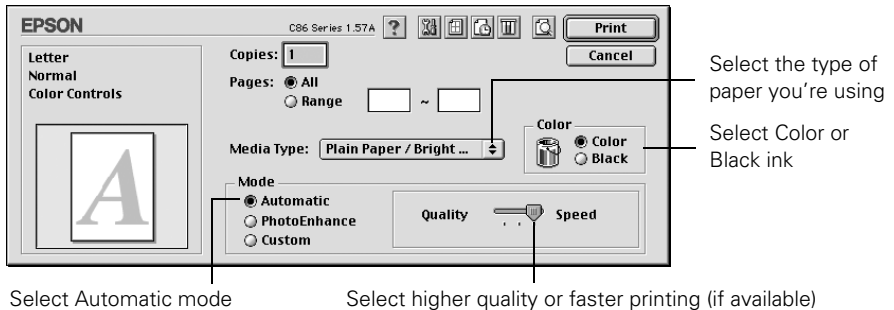





## Note:

For more information about printer settings, click the ? button.

The Quality setting on this screen gives you the best combination of quality and print speed for most prints. For instructions on printing at the highest quality (Photo RPM), see page 20.



5. You can also do the following:

- Click  to reduce or enlarge your image, print multiple layouts, or add a watermark.
- Click  to turn on background printing.
- Click  to change the Print button to Preview. You can then click it to preview your printout.
- Click  to check your ink levels.

6. Click Print.

7. If you turned on background printing, you can select **Epson Monitor IV** from the Application menu in the upper right corner of your screen. You see the Epson Monitor window:

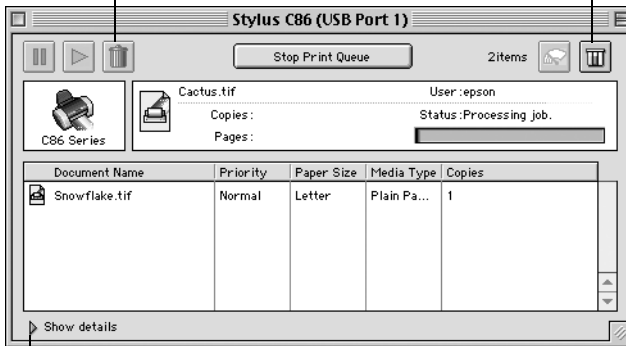

Select your print job, then click here to cancel printing

Click to check ink levels



Click here to show or hide the print settings

**Note:**

If you're not using background printing and you need to cancel printing, hold down the  key and press the . (period) key. Or press the  paper button on the printer.

---

# Installing Printer Software for Windows NT 4.x

Before you begin, complete the instructions on the *Start Here* sheet for setting up your printer. For instructions on installing printer software in Windows® XP, Me, 2000, 98, or on a Macintosh, see your *Start Here* sheet.

**Note:**

Use a parallel cable to connect the printer to your computer. Windows NT 4.x does not support a USB connection.

1. Turn on your computer. (Make sure your printer is still on.)
2. Put the Epson CD-ROM in your drive.
3. Read the license agreement and click **Agree** to continue with the installation.
4. When you see the Options Menu, click **Install Printer Driver**. Wait while the files are copied to your computer.
5. Click **OK** when you see a message that setup is complete.
6. Click **Install Printer User's Guide** and follow the on-screen instructions.
7. Click **Share Photos Online** and follow the instructions to install a link to the Epson Photo Center.<sup>SM</sup>
8. Click **Explore Photo Projects Online** and follow the instructions to install a link to the Epson Print Lab.<sup>SM</sup>
9. Click **Exit**. When you see the Epson Product Registration screen, register your printer as instructed.
10. Remove the CD-ROM and restart your computer.

**Note:**

Epson Software™ Film Factory™ does not support Windows NT 4.x.

You're ready to start printing! See the instructions beginning on page 3.

# Printing Photos

You can print beautiful snapshots and enlargements with or without white borders.

See the section on loading paper, below, then see one of the following sections for instructions on printing photos in Windows or Macintosh.

---

## Loading Paper

Here are the recommended papers and sizes for printing photos:

Paper name	Sizes	Paper Type or Media Type setting
Epson DURABrite® Ink Glossy Photo Paper	4 × 6 Letter (8.5 × 11 inches)	DURABrite Ink Glossy Photo Paper
Epson Matte Paper Heavyweight	8 × 10 Letter (8.5 × 11 inches)	Matte Paper - Heavyweight
Epson Photo Paper	4 × 6 A4 (8.3 × 11.7 inches) Letter (8.5 × 11 inches)	Glossy Photo Paper
Epson Glossy Photo Paper	4 × 6 Letter (8.5 × 11 inches)	

### Note:

You can print beautiful photographs on many other types of Epson® paper; however, those listed above support borderless printing.

With proper care, photographs from your Epson Stylus® printer will last for many years. The special Epson DURABrite inks designed for your printer are formulated to achieve improved lightfastness when used with Epson papers for prints that are properly displayed or stored. For best results, always use Epson papers.

As with traditional photos, Epson recommends proper care that will minimize color changes and lengthen display life:

- Frame prints under glass or a protective plastic sleeve to protect them from atmospheric contaminants like humidity, smoke, and high levels of ozone.
- As with all photographs, keep your prints away from direct sunlight.
- For proper storage, keep your prints in a photo album or plastic photo storage box in acid-free, archival sleeves commonly available from most camera stores.
- Always keep unused paper in the original package.

To order Epson paper, contact your dealer or call the Epson Store<sup>SM</sup> at (800) 873-7766 or visit our web site at [www.epsonstore.com](http://www.epsonstore.com) (U.S. sales only). In Canada please call (800) 463-7766 for dealer referral.

Load paper as shown:

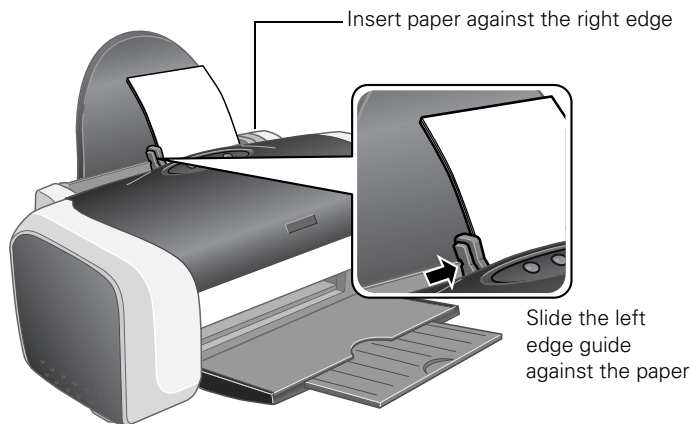

- Always load the short edge first, even for printing landscape-oriented photos.
- Load the printable side face-up. It's usually whiter or brighter than the other side.
- Make sure the paper is under the tabs on the left and right edge guides.
- Check the paper package for additional loading and printing instructions.

# Printing Photos in Windows

1. Start your photo program and open your photo file.
2. Open the File menu and click **Print**.

Make sure your printer is selected, then click **Properties** or **Preferences**. (If you see a **Setup**, **Printer**, or **Options** button, click it. Then click **Properties** or **Preferences** on the next screen.)

You see a window like this one:



3. Select **Photo** or **Best Photo** as the Quality Option setting.
4. Select the paper **Type** for the paper you're using.
5. For pictures without white borders, click the **Borderless** checkbox. Read the message and click **OK**.
6. Select your paper **Size** setting.
7. Select **Portrait** or **Landscape** as the orientation setting.
8. Do one of the following:
  - Click **OK**, then click **OK** or **Print**.
  - If you want to print at the highest resolution possible, or use special settings, continue with the steps in the next section.

# Customizing Your Photo Settings

1. On the Main tab, click the **Advanced** button in the bottom right corner of the window. If you see a warning note, click **Continue**.
2. Select the following advanced settings as necessary:

Select a color management method  
(To choose No Color Adjustment, click ICM first)

Click here to select  
Photo RPM (5760 ×  
720) for the best  
print quality on  
certain paper types

Select Print Options  
as necessary

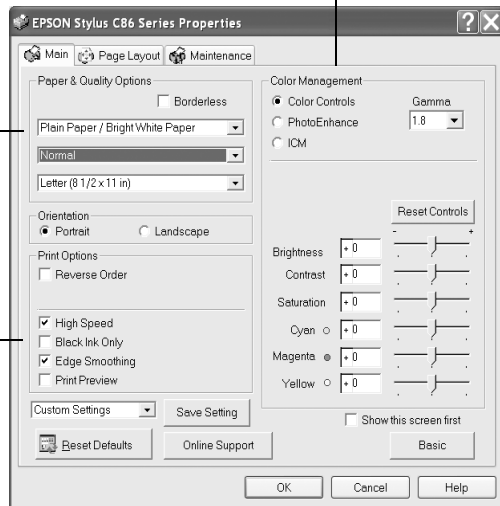

## Note:

For the highest print quality, select **Photo RPM**. Please note that printing will take longer in this mode.

3. Once you've finished selecting advanced settings, you can:
  - Click **OK** to save your settings, return to the Print window, and print.
  - Click the **Basic** button to return to the Basic settings.
  - Click the **Page Layout** tab and continue with step 4 to select layout options.

4. Select the following page layout settings as necessary:

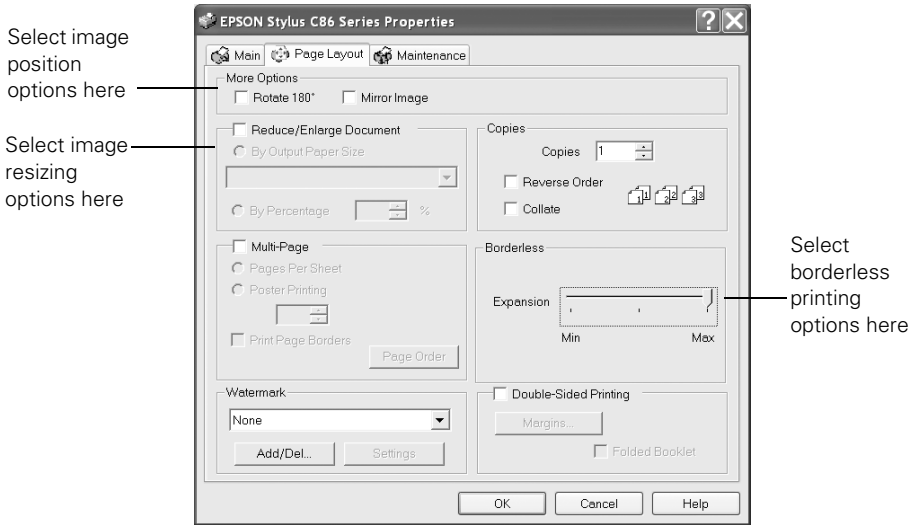

**Note:**

Some layout settings may not be available, depending on other settings you choose.

5. Select image position or resizing options as necessary. These affect only your printed image, and are not available for borderless printing.
6. If you're printing borderless photos, you can adjust the Expansion slider to choose **Min**, **Max**, or the in-between setting.

**Min** retains the entire image in your print, but there may be a small white edge on the borders of the print. **Max** expands the image to ensure that there are no unprinted edges, but the edges of the image may not appear in the print.



7. Click **OK** to save your settings, then click **OK** or **Print**.

# Printing Photos on Macintosh OS X

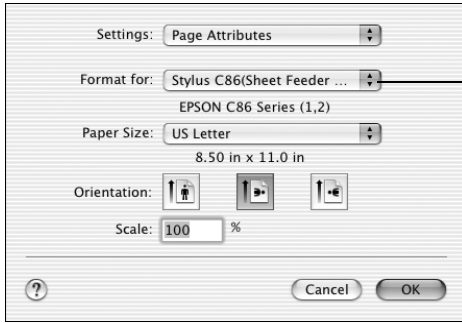
1. Start your photo program and open your photo file.
2. From the File menu select **Page Setup**. You see a window like this one:



Select Stylus C86(Sheet Feeder - Borderless) for photos without white borders

3. For pictures without white borders, select **Stylus C86(Sheet Feeder - Borderless)** in the Format for pull-down list.
4. Select your Paper Size.
5. Select  portrait or  landscape as the orientation setting.
6. Click **OK**.
7. Open the File menu and click **Print**. You see a window like this one:

Select Print Settings from the list

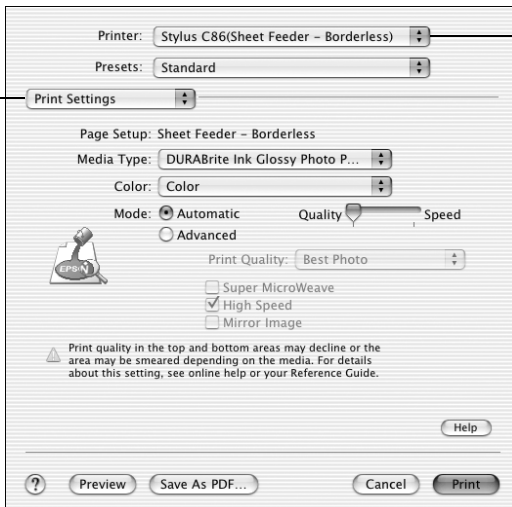

Select Stylus C86 (Sheet Feeder - Borderless) for photos without white borders



8. For pictures without white borders, select **Stylus C86(Sheet Feeder - Borderless)** in the Printer pull-down list.
9. Select **Print Settings** from the list.
10. Select the **Media Type** for the paper you're using.
11. Select **Quality** (for higher quality) or **Speed** (for faster printing) using the slider.
12. Do one of the following:
  - Click **Print**.
  - If you want to print at a higher resolution or use special settings, continue with the steps in the next section.

## Customizing Your Photo Settings

1. Click **Advanced**.
2. Select these advanced settings as necessary:

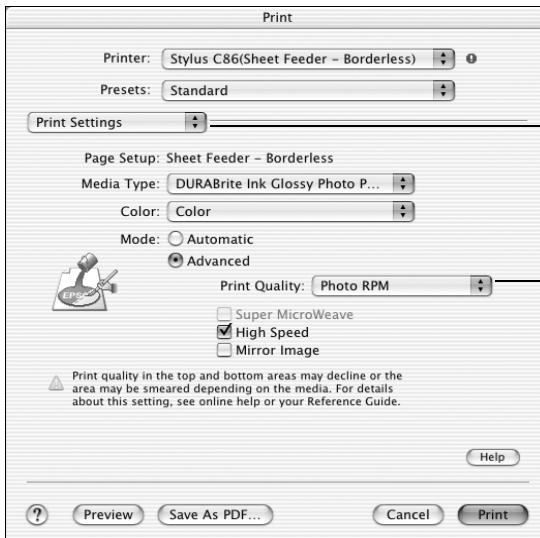

For color management settings, select **Color Management** from the list

Click here to select **Photo RPM** (5760 × 720) for the best print quality on certain paper types

### Note:

For the highest print quality, select **Photo RPM**. Please note that printing will take longer in this mode.

3. If you're printing photos without white borders, select **Expansion** from the pull-down list. You see a window like this one:

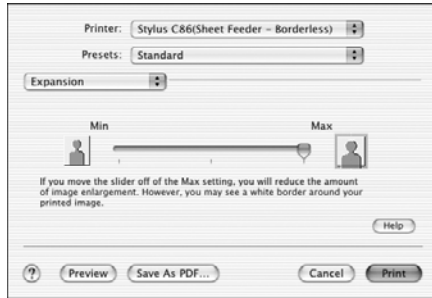

4. Adjust the Expansion slider to choose **Min**, **Max**, or the in-between setting. **Min** retains the entire image in your print, but there may be a small white edge on the borders of the print. **Max** expands the image to ensure that there are no unprinted edges, but the edges of the image may not appear in the print.
5. Click **Print**.

---

## Printing Photos on Macintosh OS 9

1. Start your photo program and open your photo file.
2. From the File menu select **Page Setup**. You see a window like this one:

Click here for photos without white borders

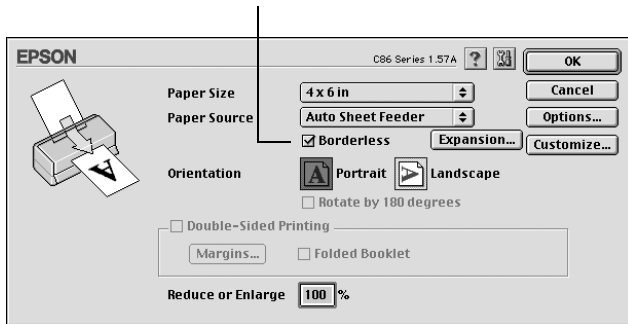

3. Select your Paper Size.

4. For photos without white borders, click the **Borderless** checkbox. Read the message and click **OK**.

Click the **Expansion** button. You see a window like this one:

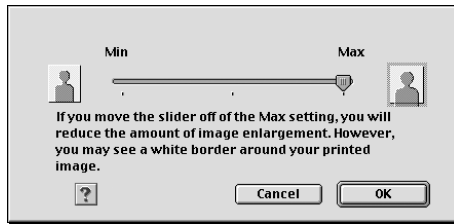

Adjust the Expansion slider to choose **Min**, **Max**, or the in-between setting.

**Min** retains the entire image in your print, but there may be a small white edge on the borders of the print. **Max** expands the image to ensure that there are no unprinted edges, but the edges of the image may not appear in the print. Then click **OK**.

5. Select **Portrait** or **Landscape** as the orientation setting.
6. Click **OK**.
7. Open the **File** menu and click **Print**. You see a window like this one:

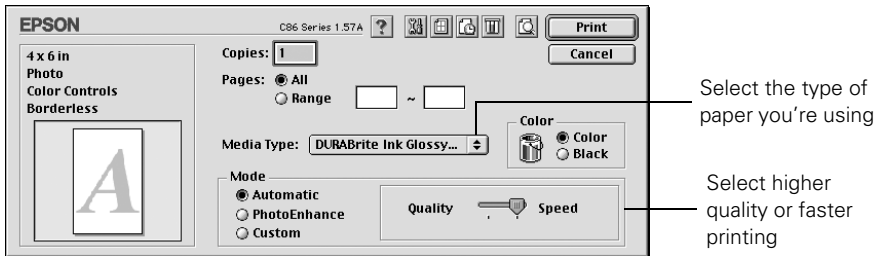

8. Select one of the **Media Type** for the paper you're using.
9. Select **Quality** (for higher quality) or **Speed** (for faster printing) using the slider.
10. Do one of the following:
  - Click **Print**.
  - If you want to select special settings for color matching or printing at a higher resolution, continue with the steps in the next section.

# Customizing Your Photo Settings

1. On the printer settings window, select Custom, then click Advanced.
2. Select these advanced settings as necessary:

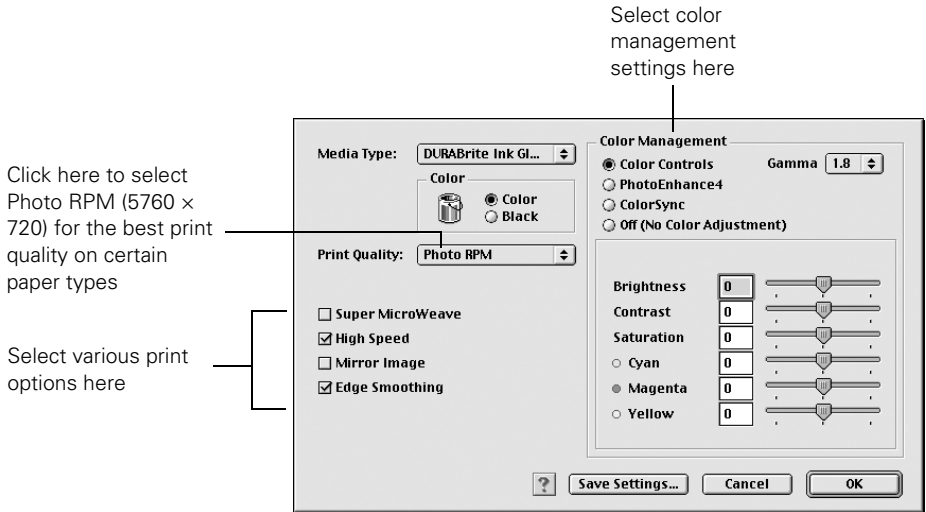



**Note:**

For the highest print quality, select **Photo RPM**. Please note that printing will take longer in this mode.

3. Click **OK** to save your settings, then click **Print**.

# Replacing Ink Cartridges

When the red  ink light flashes, one or more ink cartridges are low on ink.

When the red  ink light stays on, you need to replace the cartridge(s).

When you print, you'll also see a message on your screen telling you which cartridge is low or empty.

---

## Purchasing Ink Cartridges

Use these Epson ink cartridges within six months of installing them and before the expiration date on the package.

Ink cartridge	Part number
Black (high capacity)*	T043120
Black (standard capacity)*	T044120
Cyan	T044220
Magenta	T044320
Yellow	T044420
Color multipack (Cyan, Magenta, and Yellow)	T044520

\* Availability of black ink cartridge types varies by location.

To ensure good results, use genuine Epson ink cartridges and do not refill them. Other products may cause damage to your printer not covered by Epson's warranty.

When you need new ink cartridges, contact your dealer, or call the Epson Store at (800) 873-7766 or visit [www.epsonstore.com](http://www.epsonstore.com) (U.S. sales only). In Canada, please call (800) 463-7766 for dealer referral.

# ***Ink Cartridge Precautions***

**Warning:**

Keep ink cartridges out of the reach of children.

If ink gets on your hands, wash them thoroughly with soap and water. If ink gets in your eyes, flush them immediately with water.

Don't remove the cartridge label, or ink will leak.

Don't remove the green IC chip from the cartridge. Installing a cartridge without an IC chip can damage the printer. Avoid touching the green IC chip, as this can damage the ink cartridge.



If you remove an ink cartridge temporarily, protect the ink supply port on the bottom of the cartridge from dirt and dust. Place it in a small box, or, if you have the original packaging, return it to its own box.



Store ink cartridges in the same environment as the printer. Stand the cartridges upright (the label identifying the color should be on top).

---

# Removing and Installing Ink Cartridges

Be sure you have a new ink cartridge before you begin. Once you start replacing a cartridge, you must complete all the steps in one session.

1. Make sure the printer is turned on (the green  power light should be on, but not flashing). Then open the printer cover.
2. Press and release the  ink button.

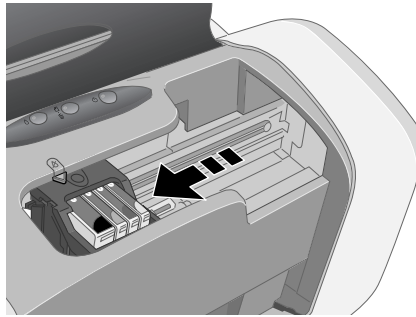

The print head moves to the left, and the cartridge that needs to be replaced stops under the  ink out mark. The  power light begins to flash.



**Caution:**

Don't hold down the  ink button for more than 2 seconds, or the printer will start to clean the print head.

To avoid damaging the printer, never move the print head by hand.

3. Press the  ink button again.
  - If more than one cartridge is empty, the next cartridge moves under the  ink out mark.
  - If all the empty cartridges have been identified, the print head moves to the ink cartridge replacement position, as shown on the following page.

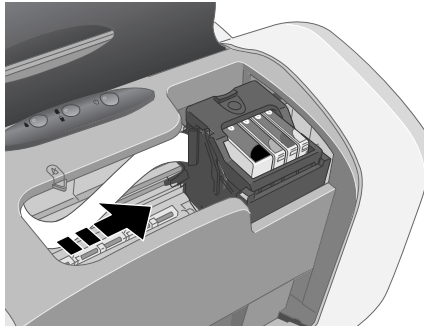

4. Open the cartridge cover.

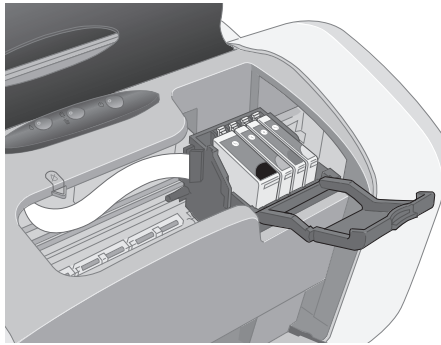

5. Squeeze the back tab of the empty cartridge as you lift it out of the printer. Don't take the used cartridge apart or try to refill it.

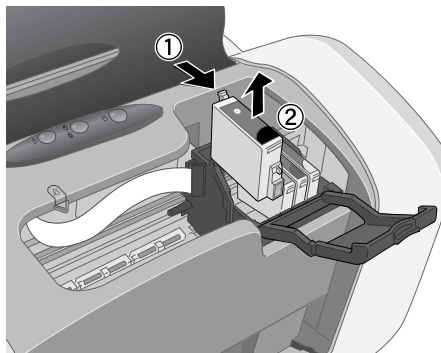

**Warning:**

If ink gets on your hands, wash them thoroughly with soap and water. If ink gets into your eyes, flush them immediately with water.



- Before you remove the new cartridge from its package, shake it four or five times.

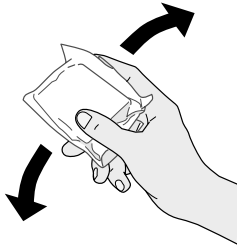

- Unwrap the new ink cartridge and lower it into the holder. Push down gently until the cartridge is firmly seated.

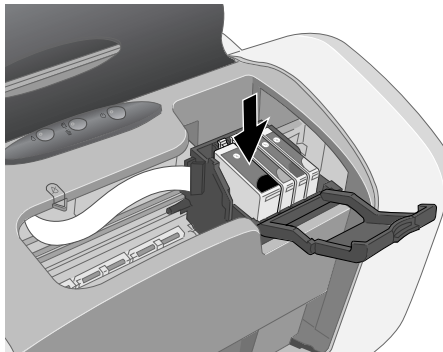

**Caution:**

Don't touch the green circuit board on the front of the cartridge; you may inhibit normal operation and printing.

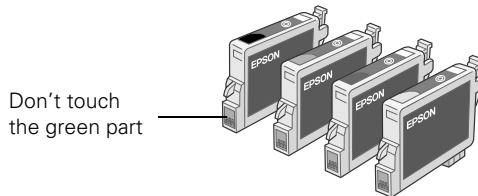

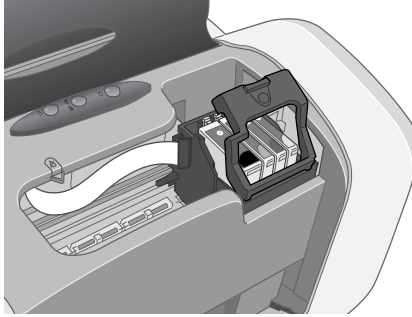

- If you need to replace other ink cartridges, repeat steps 5 through 7 before continuing with step 9.

9. Close the cartridge cover.



10. Close the printer cover and press the  ink button. The printer begins charging the ink delivery system.















The green  power light flashes and the printer makes noise. Charging takes about half a minute. When it's finished, the green  power light stops flashing and stays on, and the red  light goes out.

**Caution:**

Never turn off the printer while the green  power light is flashing, unless the printer hasn't moved or made noise for more than 5 minutes.

# Solving Problems

## Checking the Printer's Lights

Lights	Explanation
Green  power light flashes	The printer is receiving a print job, replacing an ink cartridge, charging ink, or cleaning the print head.
Red  paper light is on	Your paper ran out. Load more paper, then press the  paper button to resume printing.
Red  paper light flashes	Paper is jammed in the printer. Press the  paper button to eject the paper. If that doesn't work, turn off the printer, open the cover, and pull the paper out from the front, including any torn pieces. Then turn on the printer, reload paper, and press the  paper button.
Red  ink light flashes	One of the cartridges is low on ink. Check the message that appears on your screen to determine which cartridge is low. Make sure you have a replacement cartridge.
Red  ink light is on	One of the cartridges is out of ink or not installed. Make sure you have a replacement cartridge, then follow the steps on page 23 to install it.  If you have just installed a new cartridge, it may be incompatible with the printer or incorrectly installed. Reinstall it or replace it with the correct cartridge.
Green  power light and red  ink light are on	An ink cartridge is not installed correctly. Reinstall it as described on page 25.
Red  paper and  ink lights flash alternately	Paper may be blocking movement of the print head. Turn off the printer, then open the cover and remove any jammed paper or other foreign objects. Turn the printer back on. If the lights are still on, contact your dealer or Epson as described on page 30.
Green  power light is off; red  paper and  ink lights flash	The printer may have an internal error. Turn off the printer, wait a few seconds, and turn it on again. If the lights are still flashing, contact your dealer or Epson as described on page 30.

---

# Problems and Solutions

You see banding (light lines).





- Make sure the paper **Type** or **Media Type** setting matches the paper you're using.
- The print head nozzles may need cleaning; follow the instructions below to clean the print head:
  1. Make sure the printer is turned on but not printing, and the red  $\odot$  ink light is off.
  2. **Windows:** Right-click the  printer icon on your taskbar (in the lower right corner of your screen). Select **Head Cleaning**.

**Note:**

If you don't see the icon, go to your printer properties window as described on page 4, click the **Maintenance** tab, then select **Head Cleaning**.

**Macintosh OS X:** Open the Applications folder and select **Epson Printer Utility**. Select **Stylus C86** in the printer list, click **OK**, and select **Head Cleaning**.

**Macintosh OS 9:** Open the File menu and choose **Page Setup** or **Print**. Click the  Utility button, then click the  Head Cleaning button.

3. Follow the instructions on the screen to clean the print head.

Cleaning takes several seconds. The printer makes noise and the green  $\odot$  power light flashes.

**Caution:**

Never turn off the printer while the green  $\odot$  power light is flashing, unless the printer hasn't moved or made noise for more than 5 minutes.

4. When the green  power light stops flashing, make sure paper is loaded in the printer, then do the following:

**Windows:** Click **Print Nozzle Check Pattern**. Then click **Print**.

**Macintosh:** Click **Confirmation**, then click **Next**.

The nozzle check pattern prints.

5. If the nozzle check pattern has no gaps or white lines as shown, click **Finish**.

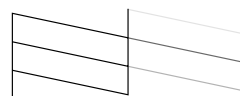

If the pattern has gaps, click **Clean** to clean the print head again.

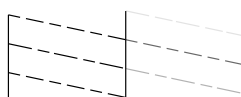



You can also turn the printer off and wait overnight—this allows any dried ink to soften—and then try cleaning the print head again.

- The ink cartridges may need replacing; see page 21 for instructions.

### **Your printout is blurry or smeared.**

- Make sure the printable (whiter) side of the paper is face-up.
- Use Epson papers to ensure proper saturation and absorption of genuine Epson ink.

### **Your paper doesn't feed correctly or jams in the printer.**

- If multiple pages feed at once, remove the paper from the sheet feeder, fan the edges to separate the sheets, then reload it.
- If paper jams, press the  paper button for several seconds to clear the jam. If that doesn't work, open the cover and pull the paper out from the front, including small pieces that may have torn off. Reload the paper and press the  paper button.
- Heavily saturated prints may curl, causing a paper jam when printing on both sides of the paper.
- Make sure you use new, smooth, high-quality paper, loaded printable side up. Don't load paper above the arrow mark inside the left edge guide. Place the paper against the right edge, behind the tab. Slide the left edge guide against it, but not too tightly.

---

## Where To Get Help

Epson provides technical assistance 24 hours a day through the electronic support services and automated telephone services listed below.

Service	Access
World Wide Web	From the Internet, you can reach Epson Support at <b><a href="http://support.epson.com">http://support.epson.com</a></b> . At this site, you can download drivers and other files, look at product documentation, access troubleshooting information, and receive technical advice through e-mail.
Automated Telephone Services	A variety of automated help services are available 24 hours a day, seven days a week. To use these services, you must have a touch tone telephone and call <b>(800) 922-8911</b> . Your Epson SoundAdvice <sup>SM</sup> Express Code is <b>70535</b> . Use this code to quickly select the Stylus C86 in SoundAdvice.

To speak to a technical support representative, dial:

- U.S.: **(562) 276-7525**, 6 AM to 8 PM, Pacific Time, Monday through Friday and 7 AM to 4 PM, Saturday.
- Canada: **(905) 709-2567**, 6 AM to 6 PM, Pacific Time, Monday through Friday.

Toll or long distance charges may apply.

Please have the following information ready:

- Product name (Epson Stylus C86)
- Product serial number (located on the back of the printer)
- Proof of purchase (such as a store receipt) and date of purchase
- Computer configuration and operating system version
- Description of the problem

You can purchase ink cartridges, paper, manuals, and accessories from the Epson Store at (800) 873-7766 or visit [www.epsonstore.com](http://www.epsonstore.com) (U.S. sales only). In Canada, please call (800) 463-7766 for dealer referral.

# Requirements and Notices

---

## Windows System Requirements

- A Microsoft® Windows compatible PC with a Pentium®-equivalent processor (233 MHz or faster recommended)
- Windows 98 SE, Windows Me, Windows 2000, Windows XP, or Windows NT 4.x
- At least 64MB RAM (128MB recommended)
- 100MB free hard disk space (200MB or more recommended)
- VGA or better display adapter and monitor (SVGA for Windows XP)
- CD-ROM or DVD drive for installing the printer software
- Parallel connection: a high-speed, bidirectional IEEE-1284 compliant parallel cable, up to 10 feet long (3 meters); the cable must have a D-SUB, 25-pin, male connector for your computer, and a 36-pin, Centronics® compatible connector for the printer.
- USB connection: a computer with preinstalled Windows 98 SE, Me, 2000, or XP, and a Windows-compliant USB port and shielded USB “AB” cable. Using an improperly shielded USB cable may cause the printer to malfunction.

---



## Macintosh System Requirements

- An Apple® iMac™ series or Power Macintosh® G3 or G4 with a built-in USB port
- Macintosh OS 9.1 or later, or OS X 10.1.3 or later
- For Mac OS 9: 32MB RAM (64MB RAM recommended)  
For Mac OS X: 128MB RAM (256MB recommended)
- At least 100MB free hard disk space (200MB recommended)
- VGA display or better
- CD-ROM or DVD drive for installing the printer software.
- A shielded USB “AB” cable. Using an improperly shielded USB cable may cause the printer to malfunction.

---

# Important Safety Instructions

Before using your printer, read these safety instructions to make sure you use it safely and effectively:

- Be sure to follow all warnings and instructions marked on the printer.
- Use only the type of power source indicated on the printer's label.
- Connect all equipment to properly grounded power outlets. Avoid using outlets on the same circuit as photocopiers or air control systems that regularly switch on and off.
- Place the printer near a wall outlet where the plug can be easily unplugged.  
*Placez l'imprimante près d'une prise de courant où la fiche peut être débranchée facilement.*
- Do not let the power cord become damaged or frayed.
- If you use an extension cord with the printer, make sure the total ampere rating of the devices plugged into the extension cord does not exceed the cord's ampere rating. Also, make sure the total ampere rating of all devices plugged into the wall outlet does not exceed the outlet's ampere rating.
- Keep your printer and computer system away from potential sources of electromagnetic interference, such as loudspeakers or cordless telephone base units.
- Avoid locations that are subject to rapid changes in heat or humidity, shocks or vibrations, or dust.
- Leave enough room around the printer for sufficient ventilation, leaving at least 3.9 inches between the back of the printer and the wall.
- Do not place the printer near a radiator or heating vent or in direct sunlight.
- Place the printer on a flat, stable surface that extends beyond the printer base in all directions. The printer will not operate properly if it is tilted or at an angle.
- When transporting or storing the printer, don't tilt it, stand it on its side, or turn it upside-down. This may allow ink to leak from the ink cartridges.
- Turn off and unplug the printer before cleaning. Clean with a damp cloth only. Do not spill liquid on the printer.  
**Caution:** Always turn the printer off using the  power button. Don't switch off the power strip or unplug the printer until the green  power light is off.
- Do not block or cover the openings in the printer's case or insert objects through the slots.
- Except as specifically explained in this manual, do not attempt to service the printer yourself.



- Unplug the printer and refer servicing to qualified service personnel under the following conditions:

If the power cord or plug is damaged; if liquid has entered the printer; if the printer has been dropped or the case damaged; if the printer does not operate normally or exhibits a distinct change in performance. Adjust only those controls that are covered by the operating instructions.

## ***Ink Cartridge Safety Instructions***

- Keep ink cartridges out of the reach of children.
- Be careful when you handle used ink cartridges; there may be ink remaining around the ink supply port. If ink gets on your skin, wash it off with soap and water. If it gets in your eyes, flush them immediately with water.
- Do not put your hand inside the printer or touch a cartridge during printing.
- Do not move the print head by hand. You may damage the printer.
- Install the ink cartridge immediately after you remove it from its package. Leaving the cartridge unpacked for a long time before use can result in reduced print quality.
- Do not use an ink cartridge beyond the date printed on the cartridge carton. For best results, use up the ink cartridges within six months of first installing them.
- Store ink cartridges in a cool, dark place.
- Store ink cartridges with the bottom of the packaging facing down.
- After bringing an ink cartridge inside from a cold storage site, allow it to warm up at room temperature for at least three hours before using it.
- Do not shake an ink cartridge after removing it from its package; this can cause leakage.
- Do not remove or tear the label on an ink cartridge; this can cause leakage.
- Do not dismantle the ink cartridges or try to refill them. This could damage the print head.
- Do not touch the green IC chip on the front of the cartridge. This may affect normal operation and printing.
- If you remove an ink cartridge for later use, protect the ink supply area from dirt and dust and store it in the same environment as the printer. Note that there is a valve in the ink supply port, making covers or plugs unnecessary, but care is needed to prevent the ink from staining items that the cartridge touches. Do not touch the ink cartridge ink supply port or surrounding area.
- Before transporting the printer, make sure the print head is capped in the far right position and the ink cartridges are in place. Secure the ink cartridge holder with the included insert to make sure it remains in the proper position.

---

# FCC Compliance Statement

## ***For United States Users***

This equipment has been tested and found to comply with the limits for a Class B digital device, pursuant to Part 15 of the FCC Rules. These limits are designed to provide reasonable protection against harmful interference in a residential installation. This equipment generates, uses, and can radiate radio frequency energy and, if not installed and used in accordance with the instructions, may cause harmful interference to radio or television reception. However, there is no guarantee that interference will not occur in a particular installation. If this equipment does cause interference to radio and television reception, which can be determined by turning the equipment off and on, the user is encouraged to try to correct the interference by one or more of the following measures:

- Reorient or relocate the receiving antenna.
- Increase the separation between the equipment and receiver.
- Connect the equipment into an outlet on a circuit different from that to which the receiver is connected.
- Consult the dealer or an experienced radio/TV technician for help.

**WARNING:** The connection of a non-shielded equipment interface cable to this equipment will invalidate the FCC Certification of this device and may cause interference levels which exceed the limits established by the FCC for this equipment. It is the responsibility of the user to obtain and use a shielded equipment interface cable with this device. If this equipment has more than one interface connector, do not leave cables connected to unused interfaces. Changes or modifications not expressly approved by the manufacturer could void the user's authority to operate the equipment.

## ***For Canadian Users***

This Class B digital apparatus complies with Canadian ICES-003.

*Cet appareil numérique de la classe B est conforme à la norme NMB-003 du Canada.*

---

# Declaration of Conformity

According to 47CFR, Part 2 and 15 for Class B Personal Computers and Peripherals; and/or CPU Boards and Power Supplies used with Class B Personal Computers:

We: Epson America, Inc.  
Located at: MS: 3-13  
3840 Kilroy Airport Way  
Long Beach, CA 90806  
Telephone: (562) 290-5254

Declare under sole responsibility that the product identified herein, complies with 47CFR Part 2 and 15 of the FCC rules as a Class B digital device. Each product marketed is identical to the representative unit tested and found to be compliant with the standards. Records maintained continue to reflect the equipment being produced can be expected to be within the variation accepted, due to quantity production and testing on a statistical basis as required by 47CFR §2.909. Operation is subject to the following two conditions: (1) this device may not cause harmful interference, and (2) this device must accept any interference received, including interference that may cause undesired operation.

Trade Name: Epson  
Type of Product: Ink Jet Printer  
Model: B251A

---

## ENERGY STAR Compliance

As an ENERGY STAR Partner, Epson has determined that this product meets the ENERGY STAR guidelines for energy efficiency. The EPA ENERGY STAR office equipment program is a voluntary partnership with the computer and office equipment industry to promote the introduction of energy-efficient personal computers, monitors, printers, fax machines, and copiers in an effort to reduce air pollution caused by power generation.



---

# Epson America, Inc. Limited Warranty

*What Is Covered:* Epson America, Inc. (“Epson”) warrants to the first retail purchaser that the Epson printer covered by this limited warranty statement, if purchased and operated only in the United States or Canada, conforms to the manufacturer’s specifications and will be free from defects in workmanship and materials for a period of one (1) year from the date of original purchase. Epson also warrants that the consumable ink cartridges enclosed with the printer will perform to the manufacturer’s specified usage, which usage may expire before the expiration of the limited warranty for the Epson printer. For warranty service, you must provide proof of the date of original purchase.

*What Epson Will Do To Correct Problems:* Should your Epson printer prove defective during the warranty period, please call the Epson Connection<sup>SM</sup> at (562) 276-7525 (U.S.) or (905) 709-2567 (Canada) for repair instructions and return authorization. An Epson service technician will provide telephone diagnostic service to determine whether the printer requires service. If service is needed, Epson will, at its option, exchange or repair the printer without charge for parts or labor. If Epson authorizes an exchange for the defective unit, Epson will ship a replacement printer to you, freight prepaid, so long as you use an address in Canada or the U.S. (excluding Puerto Rico and U.S. Possessions). Shipments to other locations will be made freight collect. You are responsible for securely packaging the defective unit or any requested parts and returning them to Epson within five (5) working days of receipt of the replacement. Epson requires a debit or a credit card number to secure the cost of the replacement printer in the event that you fail to return the defective one. If your printer is being repaired, Epson will direct you to send your printer to Epson or its authorized service center, where the printer will be fixed and sent back to you. You are responsible for packing the printer and for all costs to and from the Epson authorized service center. When warranty service involves the exchange of the printer or a part, the item replaced becomes Epson property. The replacement printer or part may be new or refurbished to the Epson standard of quality, and, at Epson’s option, may be another model of like kind and quality. Epson’s liability for replacement of the covered printer will not exceed the original retail selling price of the covered printer. Exchange products and parts assume the remaining warranty period of your original product covered by this limited warranty.

*What This Warranty Does Not Cover:* This warranty does not apply to refurbished or reconditioned products. This warranty covers only normal use in the United States and Canada. This warranty is not transferable. This warranty does not cover any color change or fading of prints or reimbursement of materials or services required for reprinting. This warranty does not cover damage to the Epson product caused by parts or supplies not manufactured, distributed or certified by Epson. This warranty does not cover ribbons, ink cartridges or third party parts, components, or peripheral devices added to the Epson product after its shipment from Epson, e.g., dealer or user-added boards or components. Epson is not responsible for warranty service should the Epson label or logo or the rating

label or serial number be removed or should the product fail to be properly maintained or fail to function properly as a result of misuse, abuse, improper installation, neglect, improper shipping, damage caused by disasters such as fire, flood, and lightning, improper electrical current, software problems, interaction with non-Epson products, or service other than by an Epson Authorized Servicer. If a claimed defect cannot be identified or reproduced, you will be held responsible for the costs incurred.

THE WARRANTY AND REMEDY PROVIDED ABOVE ARE EXCLUSIVE AND IN LIEU OF ALL OTHER EXPRESS OR IMPLIED WARRANTIES INCLUDING, BUT NOT LIMITED TO, THE IMPLIED WARRANTIES OF MERCHANTABILITY, NON-INFRINGEMENT OR FITNESS FOR A PARTICULAR PURPOSE. SOME LAWS DO NOT ALLOW THE EXCLUSION OF IMPLIED WARRANTIES. IF THESE LAWS APPLY, THEN ALL EXPRESS AND IMPLIED WARRANTIES ARE LIMITED TO THE WARRANTY PERIOD IDENTIFIED ABOVE. UNLESS STATED HEREIN, ANY STATEMENT OR REPRESENTATIONS MADE BY ANY OTHER PERSON OR FIRM ARE VOID. EXCEPT AS PROVIDED IN THIS WRITTEN WARRANTY, NEITHER EPSON AMERICA, INC. NOR ITS AFFILIATES SHALL BE LIABLE FOR ANY LOSS, INCONVENIENCE, OR DAMAGE, INCLUDING DIRECT, SPECIAL, INCIDENTAL OR CONSEQUENTIAL DAMAGES, RESULTING FROM THE USE OR INABILITY TO USE THE EPSON PRODUCT, WHETHER RESULTING FROM BREACH OF WARRANTY OR ANY OTHER LEGAL THEORY.

In Canada, warranties include both warranties and conditions.

Some jurisdictions do not allow limitations on how long an implied warranty lasts, and some jurisdictions do not allow the exclusion or limitation of incidental or consequential damages, so the above limitations and exclusions may not apply to you. This warranty gives you specific legal rights and you may have other rights which vary from jurisdiction to jurisdiction.

Epson America, Inc. - P.O. Box 93012 - Long Beach, CA 90809-3012

## Copyright Notice

All rights reserved. No part of this publication may be reproduced, stored in a retrieval system, or transmitted in any form or by any means, electronic, mechanical, photocopying, recording, or otherwise, without the prior written permission of Seiko Epson Corporation. The information contained herein is designed only for use with this Epson product. Epson is not responsible for any use of this information as applied to other equipment.

Neither Seiko Epson Corporation nor its affiliates shall be liable to the purchaser of this product or third parties for damages, losses, costs, or expenses incurred by purchaser or third parties as a result of: accident, misuse, or abuse of this product or unauthorized modifications, repairs, or alterations to this product, or (excluding the U.S.) failure to strictly comply with Seiko Epson Corporation's operating and maintenance instructions.

Seiko Epson Corporation shall not be liable for any damages or problems arising from the use of any options or any consumable products other than those designated as Original Epson Products or Epson Approved Products by Seiko Epson Corporation.

### Responsible Use of Copyrighted Materials

Digital cameras, scanners, and ink jet printers, like conventional photocopiers and cameras, can be misused by improper copying or printing of copyrighted material. While some countries' laws permit limited copying of copyrighted material in certain circumstances, those circumstances may not be as broad as some people assume. Epson encourages each user to be responsible and respectful of the copyright laws when using digital cameras, scanners, and ink jet printers.

### Trademarks

Epson and Epson Stylus are registered trademarks of Seiko Epson Corporation.

DURABrite and RPM are registered trademarks; Epson Software is a trademark; and SoundAdvice, Epson Connection, Epson Print Lab, Epson PhotoCenter, and Epson Store are service marks of Epson America, Inc.

General Notice: Other product names used herein are for identification purposes only and may be trademarks of their respective owners. Epson disclaims any and all rights in those marks.

The ENERGY STAR emblem does not represent EPA endorsement of any product or service.



