

***THERMAL PRINTER***

**TSP600 SERIES**

***USER'S MANUAL***

***MODE D'EMPLOI***

***BEDIENUNGSANLEITUNG***

***MANUALE DI ISTRUZIONI***

**star** 

**Federal Communications Commission  
Radio Frequency Interference  
Statement**

This equipment has been tested and found to comply with the limits for a Class A digital device, pursuant to Part 15 of the FCC Rules. These limits are designed to provide reasonable protection against harmful interference when the equipment is operated in a commercial environment. This equipment generates, uses and can radiate radio frequency energy and, if not installed and used in accordance with the instruction manual, may cause harmful interference to radio communications. Operation of this equipment in a residential area is likely to cause harmful interference in which case the user will be required to correct the interference at his own expense.

For compliance with the Federal Noise Interference Standard, this equipment requires a shielded cable.

*This statement will be applied only for the printers marketed in U.S.A.*

**Statement of  
The Canadian Department of Communications  
Radio Interference Regulations**

This digital apparatus does not exceed the Class A limits for radio noise emissions from digital apparatus set out in the Radio Interference Regulations of the Canadian Department of Communications.

Le présent appareil numérique n'émet pas de bruits radioélectriques dépassant les limites applicables aux appareils numériques de la classe A prescrites dans le Règlement sur le brouillage radioélectrique édicté par le ministère des Communications du Canada.

*The above statement applies only to printers marketed in Canada.*

**CE  
Manufacturer's Declaration of Conformity**

***EC Council Directive 89/336/EEC of 3 May 1989***

This product, has been designed and manufactured in accordance with the International Standards EN 50081-1/01.92 and EN 50082-1/01.92, following the provisions of the Electro Magnetic Compatibility Directive of the European Communities as of May 1989.

***EC Council Directive 73/23/EEC and 93/68/EEC of 22 July 1993***

This product, has been designed and manufactured in accordance with the International Standards EN 60950, following the provisions of the Low Voltage Directive of the European Communities as of July 1993.

*The above statement applies only to printers marketed in EU.*

***Trademark acknowledgments***

**TSP600:** Star Micronics Co., Ltd.

**ESC/POS:** Seiko Epson Corporation

***Notice***

- All rights reserved. Reproduction of any part of this manual in any form whatsoever, without STAR's express permission is forbidden.
- The contents of this manual are subject to change without notice.
- All efforts have been made to ensure the accuracy of the contents of this manual at the time of going to press. However, should any errors be detected, STAR would greatly appreciate being informed of them.
- The above notwithstanding, STAR can assume no responsibility for any errors in this manual.

# TABLE OF CONTENTS

<b>1. Parts Identification and Nomenclature .....</b>	<b>1</b>
<b>2. Consumable Parts and AC Adapter .....</b>	<b>4</b>
<b>3. Connecting Cables and AC Adapter .....</b>	<b>6</b>
3-1. Interface Cable .....	6
3-2. Connecting to a Peripheral Unit .....	8
3-3. Connecting the Optional AC Adapter .....	9
3-4. Turning Power On .....	10
<b>4. Control Panel and Other Functions .....</b>	<b>11</b>
4-1. Control Panel .....	11
4-2. Errors .....	11
4-3. Self Printing .....	13
<b>5. Loading the Roll Paper .....</b>	<b>14</b>
<b>6. Adjusting the Near-end Sensor .....</b>	<b>17</b>
<b>7. Preventing and Clearing Paper Jams .....</b>	<b>19</b>
7-1. Preventing Paper Jams .....	19
7-2. Removing Paper Jam .....	19
7-3. Releasing a locked Cutter (Auto Cutter Mode only) .....	20
<b>8. Periodical Cleaning .....</b>	<b>22</b>
8-1. Cleaning the Thermal Head .....	22
8-2. Cleaning the Paper Holder .....	22
<b>Appendix A: Specifications .....</b>	<b>95</b>
A-1. General Specifications .....	95
A-2. Auto Cutter Specifications .....	96
A-3. Interface .....	96
A-4. Electrical Characteristics .....	96
A-5. Option .....	96
A-6. Environmental Requirements .....	97
A-7. Reliability .....	97
<b>Appendix B: Dip Switch Setting .....</b>	<b>98</b>
B-1. Parallel Interface Type .....	99
B-2. Serial Interface Type .....	101
<b>Appendix C: Parallel Interface .....</b>	<b>104</b>
<b>Appendix D: Serial Interface .....</b>	<b>105</b>
D-1. RS-232C Connector .....	106
D-2. Cable Connections .....	107
D-3. Electrical Characteristics .....	107
<b>Appendix E: Peripheral Unit Drive Circuit .....</b>	<b>108</b>
<b>Appendix F: Memory Switch Settings .....</b>	<b>109</b>

Please access the following URL

[http://www.star-micronics.co.jp/service/frame\\_sp\\_spr\\_e.htm](http://www.star-micronics.co.jp/service/frame_sp_spr_e.htm)

for the latest revision of the manual.

# 1. Parts Identification and Nomenclature

## Auto Cutter Model

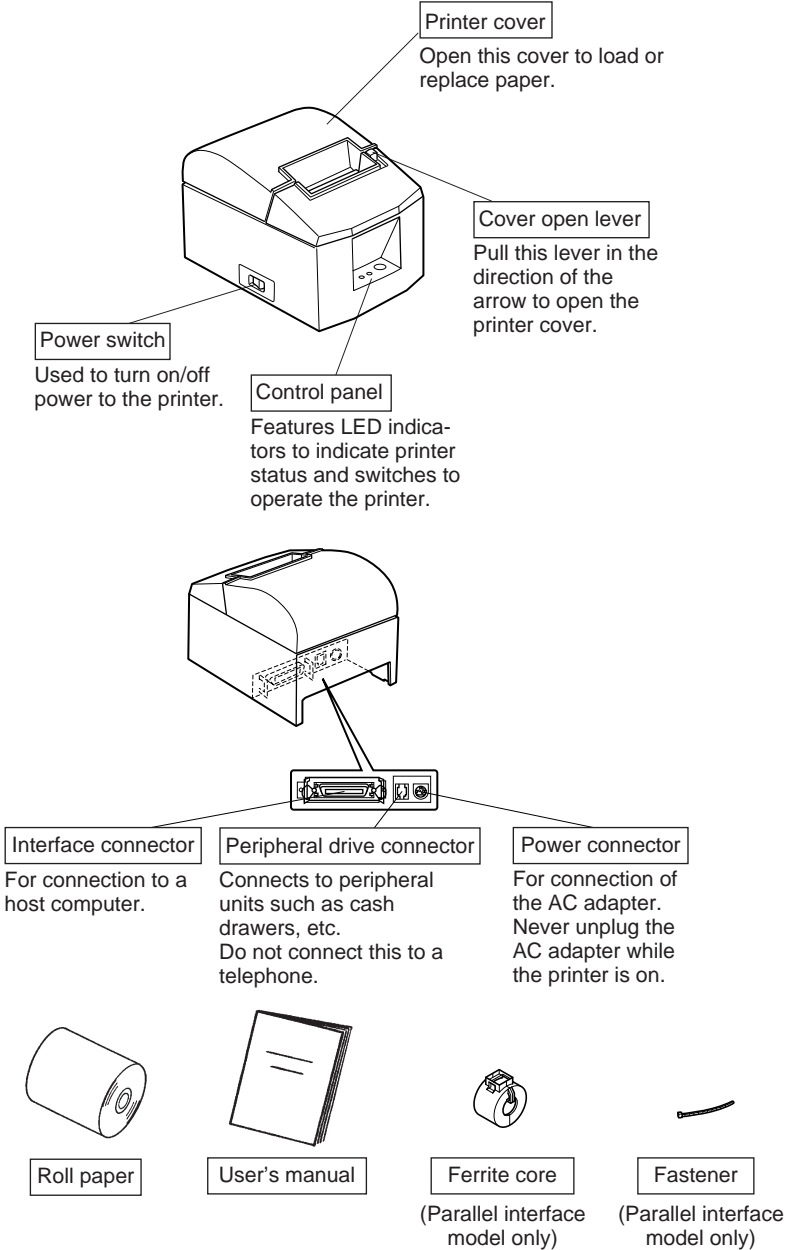

# Tear Bar Model

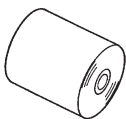
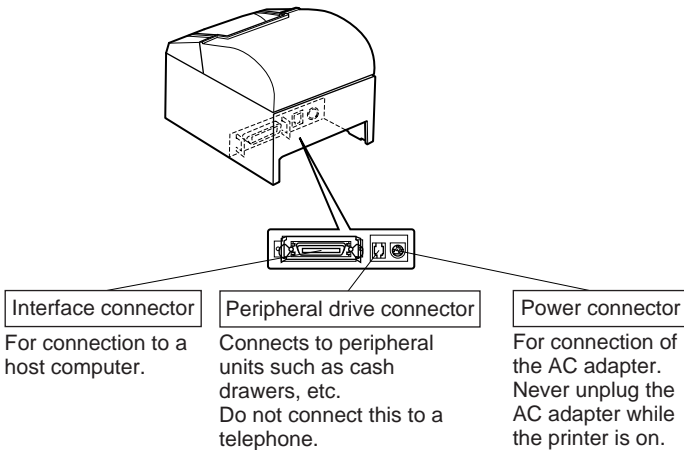
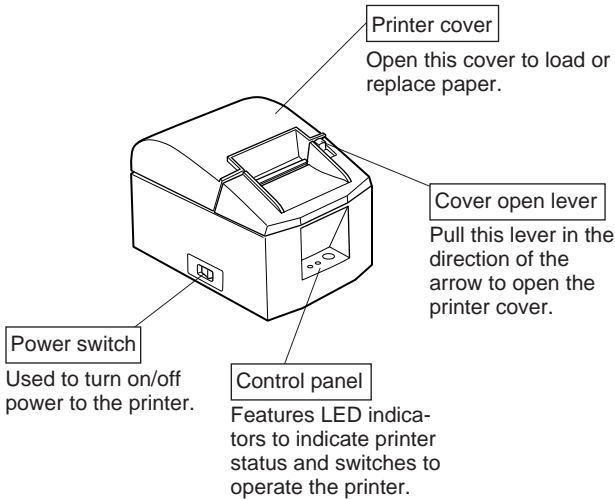

Roll paper



User's manual



Ferrite core  
(Parallel interface model only)



Fastener  
(Parallel interface model only)

## Choosing a place for the printer

Before actually unpacking the printer, you should take a few minutes to think about where you plan to use it. Remember the following points when doing this.

- ✓ Choose a firm, level surface where the printer will not be exposed to vibration.
- ✓ The power outlet you plan to connect to for power should be nearby and unobstructed.
- ✓ Make sure that the printer is close enough to your host computer for you to connect the two.
- ✓ Make sure that the printer is not exposed to direct sunlight.
- ✓ Make sure that the printer is well away from heaters and other sources of extreme heat.
- ✓ Make sure that the surrounding area is clean, dry, and free of dust.
- ✓ Make sure that the printer is connected to a reliable power outlet. It should not be on the same electric circuit as copiers, refrigerators, or other appliances that cause power spikes.
- ✓ Make sure that the room where you are using the printer is not too humid.

## 2. Consumable Parts and AC Adapter

When consumable parts have run out, use those specified in the table below. Make sure that the AC adapter specified in the table is used.

Use of consumable parts or AC adapter which are not specified in the table may result in damage to the printer, fire or electric shock.

### (1) Roll paper specification

Thermal paper

Thickness: 65~85  $\mu\text{m}$

Width: 79.5 $\pm$ 0.5 mm (57.5 $\pm$ 0.5 mm when the optional paper roller holder is used)

Outer roll diameter:  $\phi$ 90 mm or less

Take up paper roll width: 80 $^{+0.5}_{-1}$  mm or (58 $^{+0.5}_{-1}$  mm when the optional paper roller holder is used)

Core outer/inner diameter

Paper thickness	Core outer	Core inner
65~85 $\mu\text{m}$	$\phi$ 18 $\pm$ 1 mm	$\phi$ 12 $\pm$ 1 mm

Printed surface: Outer edge of roll

Tail end handling: Do not use paste or glue to secure the roll paper or its core.

Do not fold the tail end of the paper.

### (2) Recommended paper

Mitsubishi Paper Mills Limited

P220AG (normal type paper), 65  $\mu\text{m}$  (thickness)

HP220A (high image stability paper), 65  $\mu\text{m}$  (thickness)

HP220AB-1 (high image stability paper), 75  $\mu\text{m}$  (thickness)

P220AB (normal type paper, card ticket), 85  $\mu\text{m}$  (thickness)

Oji Paper Co., Ltd.

PD150R (normal type paper), 75  $\mu\text{m}$  (thickness)

PD160R (high image stability paper), 65/75  $\mu\text{m}$  (thickness)

Nippon Paper Industries

TF50KS-E2C (normal type paper), 65  $\mu\text{m}$  (thickness)

Depending on the type and thickness of the paper, it may be necessary to change the settings for printing darkness. To change the darkness settings, use the printing darkness settings command <ESC><RS> 'd' n. Refer to the separate programmer's manual for details.

(3) AC adapter (option)

Model name: PS60-24 A

Input: 100 to 240 V AC, 50/60 Hz

Output: DC24±5%, 2.0 A (5.0 A Load 10 sec. Max)

---

***Important!***

*Access the following URL for the information of the recommended paper.*  
*<http://www.star-micronics.co.jp/>*

---



# 3. Connecting Cables and AC Adapter

## 3-1. Interface Cable

### 3-1-1. Ferrite Core Installation (Parallel interface model only)

- (1) For only the parallel interface model, affix the ferrite core onto the cable as shown in the illustration below.

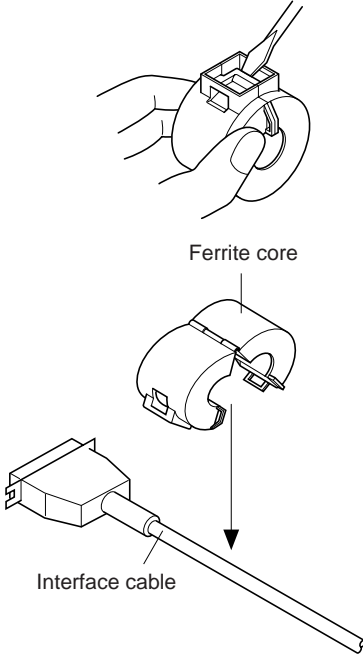

- (2) Pass the fastener through the ferrite core.

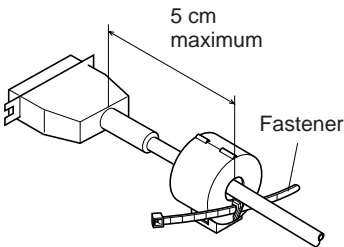

- (3) Loop the fastener around the cable and lock it. Use scissors to cut off any excess.

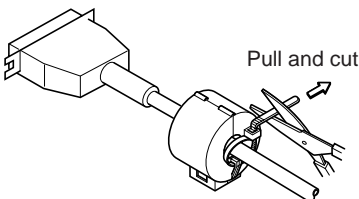

### 3-1-2. Connecting the Interface Cable

**Note:** Before connecting/disconnecting the interface cable, make sure that power to the printer and all the devices connected to the printer is turned off.

**Also make sure the power cable plug is disconnected from the AC outlet.**

- (1) Connect the interface cable to the connector on the rear panel of the printer.
- (2) In the case of a serial interface, tighten the connector screws. In the case of a parallel interface, fasten the connector clasps.

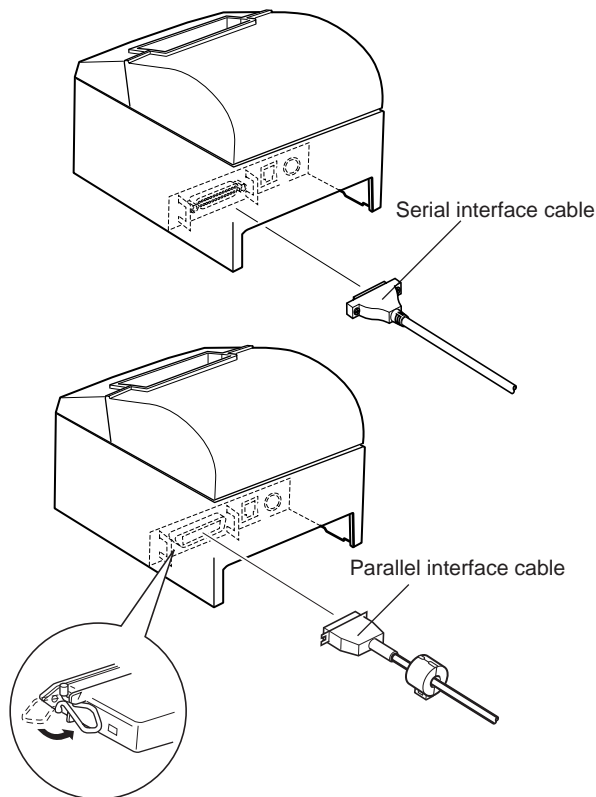

## 3-2. Connecting to a Peripheral Unit

You can connect a peripheral unit to the printer using a modular plug. The following describes how to install the ferrite core and make the actual connection. See “Modular plug” on page 108 for details about the type of modular plug that is required. Note that this printer does not come with a modular plug or wire, so it is up to you to obtain one that suits your needs.

---

**Important!**

*Make sure that the printer is turned off and unplugged from the AC outlet and that the computer is turned off before making connections.*

---

(1) Connect the peripheral drive cable to the connector on the rear panel of the printer.

---

**Important!**

*Do not connect a telephone line into the peripheral drive connector. Failure to observe this may result in damage to the printer. Also, for safety purposes, do not connect wiring to the external drive connector if there is a chance it may carry peripheral voltage.*

---

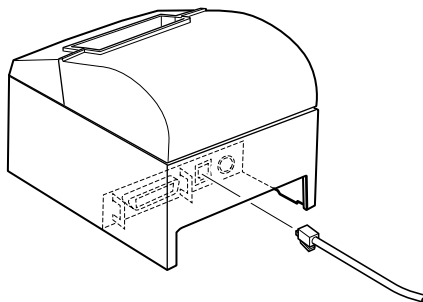

### 3-3. Connecting the Optional AC Adapter

**Note:** Before connecting/disconnecting the AC adapter, make sure that power to the printer and all the devices connected to the printer is turned off. Also make sure the power cable plug is disconnected from the AC outlet.

(1) Connect the AC adapter to the power cable.

**Note:** Use only the standard AC adapter and power cable.

(2) Connect AC adapter to the connector on the printer.

(3) Insert the power cable plug into an AC outlet.

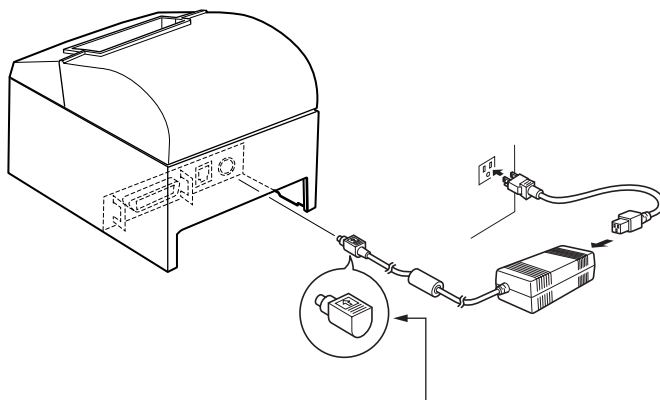

---

#### ***Important!***

When disconnecting the power cable, take hold of the cable connector to pull it out. Releasing the lock makes it easy to disconnect the connector.

Pulling the power cable excessively could cause damage to the connector.

---

### 3-4. Turning Power On

Make sure that the AC adapter has been connected as described in 3-3.

- (1) Set the power switch located on the front of the printer to on.  
The POWER lamp on the control panel will light up.

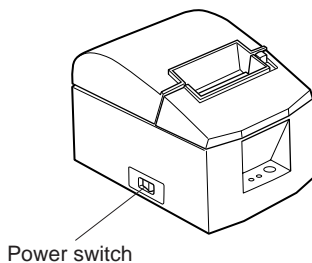

---

#### ***Important!***

*We recommend that you unplug the printer from the power outlet whenever you do not plan to use it for long periods. Because of this, you should locate the printer so that the power outlet it is plugged into is nearby and easy to access.*

---

## 4. Control Panel and Other Functions

### 4-1. Control Panel

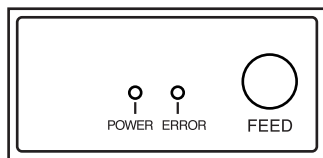

① POWER lamp (Green LED)  
Lights when the power is ON

② ERROR lamp (Red LED)  
Indicates various errors in combination with POWER lamp

③ FEED button  
Press the FEED button to feed roll paper.

### 4-2. Errors

#### 1) Automatically recoverable error

Error Description	POWER lamp	ERROR lamp	Recovery Conditions
Head high temperature detection	Flashes at 0.5 second intervals	Off	Automatically recovered after the print head has cooled.
Cover open error	On	On	Automatically recovered by closing the printer cover.

#### 2) Non recoverable error

Error Description	POWER lamp	ERROR lamp	Recovery Conditions
RAM error	Off	On	This is not a recoverable error. Consult dealer for repairs.
Memory SW error	Flashes at 0.25 second intervals	Flashes at 0.25 second intervals	This is not a recoverable error. Consult dealer for repairs.
Thermistor error	Flashes at 0.5 second intervals	Flashes at 0.5 second intervals	This is not a recoverable error. Consult dealer for repairs.
Power supply error	Flashes at 1 second intervals	Flashes at 1 second intervals	This is not a recoverable error. Consult dealer for repairs.

#### Note

- 1) If a non recoverable error occurs, turn the power OFF immediately.
- 2) When Power supply error occurs, there is a possibility that the power supply unit has a trouble.  
For other non recoverable errors, please consult the dealer for repairs.

### 3) Paper cut error

Error Description	POWER lamp	ERROR lamp	Recovery Conditions
Paper cut error	Off	Flashes at 0.125 second intervals	Recovered If the cutter returns to the home position after turning the power OFF and ON. Restoration is also possible with the <DLE><ENQ>n command when in the ESC/POS mode.

#### Note

- 1) If the cutter doesn't return to the home position, or doesn't perform the initial movement, it cannot be recovered.
- 2) If the paper is jammed, turn the power off, clear the jammed paper, then turn the power ON.
- 3) Handling paper cut errors that occur in the printer status.  
STAR Mode: Non recoverable error  
ESC/POS MOde: Recoverable error

### 4) Paper detection error

Error Description	POWER lamp	ERROR lamp	Recovery Conditions
Paper out error	On	Flashes at 0.5 second intervals	Automatically recovered by loading a new paper roll, then closing the printer cover.
Paper near end	On	Flashes at 2 second intervals	Indicators show that the paper end is approaching, but the printer continues to print.





## 5. Loading the Roll Paper

Be sure to use roll paper that matches the printer's specification.  
When using a paper roll with an 57.5 mm width, install the optional paper roll holder as described on the following page.

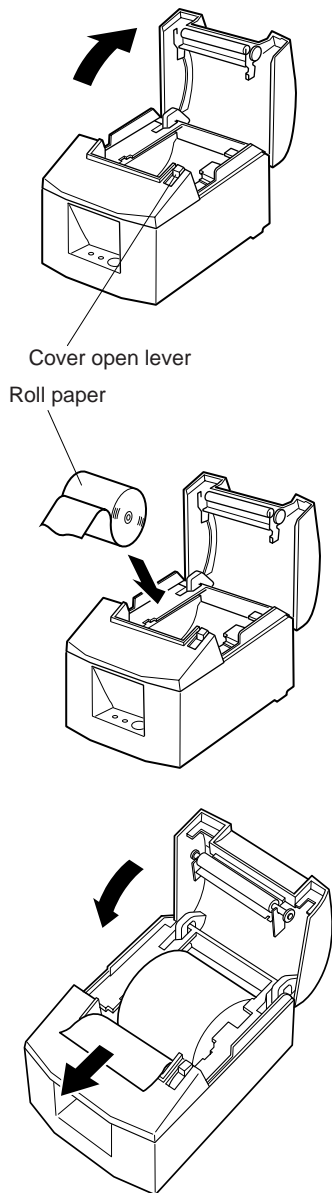

1) Push the Cover open lever, and open the printer cover.

2) While observing the direction of the roll, set the paper roll into the hollow, and pull on the leading edge of the paper toward you.

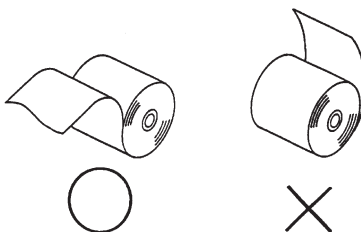

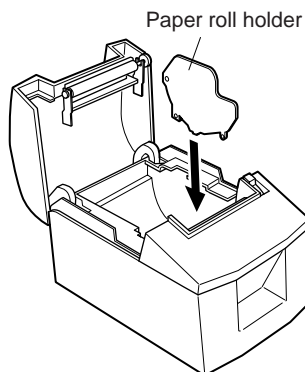

**Note:** When using a paper roll with an 57.5 mm width, install the optional paper roll holder in the groove in the printer.

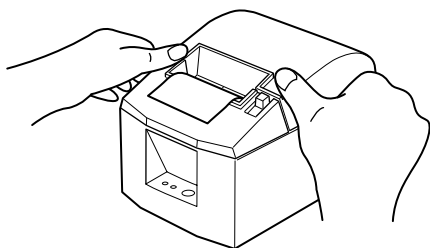

3) Push down both sides of the printer cover to close.

**Note:** Make sure that the printer cover is securely closed.

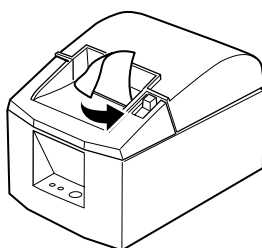

**Tear Bar Model**

4) **Tear Bar Model:**

Tear off the paper as shown.

**Auto Cutter Model:**

If the printer cover is closed after turning on the power, the cutter operates automatically and the front end of the paper is cut.

---

**Important!**

1. *Do not touch the cutter blade.*
    - *There is a cutter inside the paper outlet slot. Not only should you not put your hand in the paper outlet slot while printing is in progress, never put your hand into the outlet even when printing is not in progress.*
    - *The printer cover can be opened when replacing the paper. However, since the cutter blade is on the inside of the printer cover, be careful not to place your face or hands too close to the cutter blade.*
  2. *Do not pull the cover open lever and open the printer cover when printing is in progress or when the auto cutter is operating.*
  3. *Do not operate the cover open lever while pressing on the printer cover with your hand.*
  4. *Do not pull out paper while the printer cover is closed.*
  5. *The heating element and the driver IC of the thermal head are easily damaged. Do not touch them with metal objects, sandpaper, etc.*
  6. *During and immediately after printing, the area around the thermal head is very hot. Do not touch it, as you could be burned.*
  7. *Printing quality may suffer if the thermal head heating element becomes soiled by being touched with your hands. Do not touch the thermal head heating element.*
  8. *There is a risk of damage to the driver IC of the thermal head from static electricity. Never directly touch the IC.*
  9. *The printing quality and working life of the thermal head cannot be guaranteed if any paper other than that recommended is used. In particular, paper containing [Na<sup>+</sup>, K<sup>+</sup>, Cl<sup>-</sup>] may drastically reduce the working life of the thermal head. Please exercise caution.*
  10. *Do not operate the printer if there is moisture on the front surface of the head from condensation, etc.*
-

## 6. Adjusting the Near-end Sensor

Use the following procedure to adjust the near-end sensor so it is compatible with the size of roll paper you are using.

- ① Open the printer cover.
- ② Determine the diameter of the roll paper you are using and find the required setting in the table below.
- ③ Insert the tip of a ballpoint pen or similar object into the hole of the adjuster, and then push and side the adjuster to the desired setting.

When changing the setting, make sure that the position of the hole is aligned with the alignment mark indicated by the arrow.

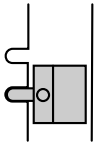
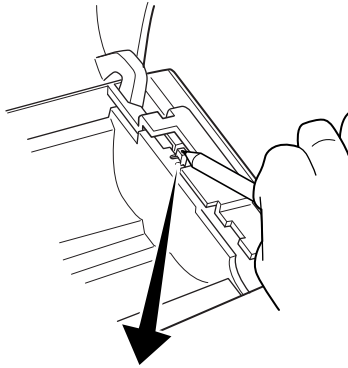

(Level 1)

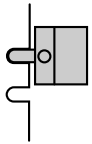

(Level 2)

## Adjustment value according to the paper you are using

Paper thickness ( $\mu\text{m}$ )	When using the paper roll with a core whose inside diameter (A): $\phi 12$ , outside diameter (B): $\phi 18$			
	Detected diameter (C) (Approx. mm)		Remained paper length (Approx. m)	
	Level 1	Level 2	Level 1	Level 2
65	$\phi 23$	$\phi 29$	2.7	7.3
85	$\phi 21$		1.2	5.5

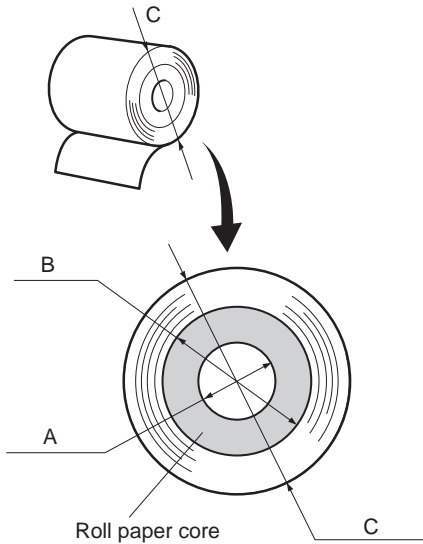

### Note

- 1) The standard model is set to level 1 prior to being shipped from the factory.
- 2) The C dimension and the remained paper length are the calculated values. There may be some variations in actual mechanism.
- 3) As looseness will occur with the paper, leading to an increase in discrepancies between the C dimensions and remaining paper length, when the paper being used has a printer thickness of  $85 \mu\text{m}$ , it is recommended that Level 2 is used.

## 7. Preventing and Clearing Paper Jams

### 7-1. Preventing Paper Jams

The paper should not be touched during ejection and before it is cut. Pressing or pulling the paper during ejection may cause a paper jam, paper cutting failure or line feed failure.

### 7-2. Removing Paper Jam

If a paper jam occurs, clear it as described below.

(1) Set the power switch to off to turn off power to the printer.

(2) Pull the lever toward you to open the printer cover.

If the printer cover will not open on auto cutter models, it means that the auto cutter is not at the home position. In this case, return the auto cutter to the home position by following the instructions provided in section 7-3. Then open the printer cover after the paper jam has been removed.

(3) Remove the jammed paper.

**Note:** Take care not to damage the printer when removing the jammed paper. Since it is easy to damage the thermal head in particular, take care not to touch it.

(4) Position the roll paper straight and close the printer cover gently.

**Note 1:** Make sure that the paper is positioned straight. If the printer cover is closed with the paper skewed, a paper jam may result.

**Note 2:** Lock the printer cover by pressing down on the sides. Do not try to close it by pressing down on the center. The cover may not lock properly.

(5) Set the power switch to on to turn on power to the printer. Make sure that the ERROR LED is not lit.

**Note:** While the ERROR LED is lit, the printer will not accept any commands such as the print command, so make sure that the printer cover is locked properly.

### 7-3. Releasing a Locked Cutter (Auto Cutter Mode only)

If the auto cutter locks up or fails to cut the paper, follow the steps below.

---

#### **Caution**

*Since working on the cutter may be dangerous, be sure to turn off the printer first.*

---

- (1) Set the power switch to OFF to turn off the printer.
- (2) Slide off the front cover to reveal the auto cutter.
- (3) Remove any jammed paper.

**Note:** Be careful not to damage the printer while removing any jammed paper.

Since the thermal print head is particularly sensitive, be sure not to touch it.

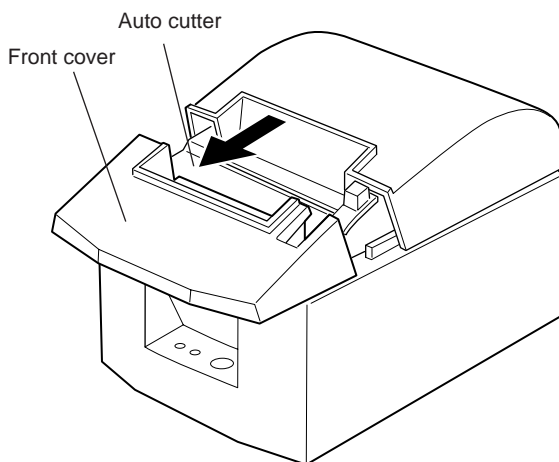

- (4) If the cutter's moving blade is protruding, use a Phillips screwdriver to turn the Phillip-head screw and return the moving blade to its home position. When the check window is completely white, the moving blade is at its home position.

**Note 1:** Do not apply extreme pressure to the moving blade.

**Note 2:** If the moving blade is protruding too much, the printer cover cannot be opened. Trying to open the printer cover may damage the cutter.

- (5) Open the printer cover, remove any jammed paper, and then re-install the paper roll.
- (6) Install the front cover, and then set the power switch to ON.

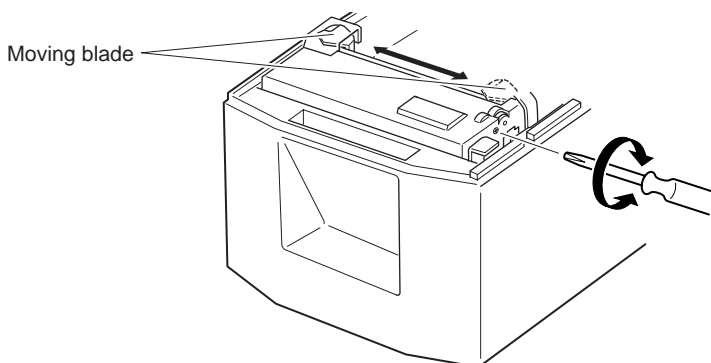



## 8. Periodical Cleaning

Printed characters may become partially unclear due to accumulated paper dust and dirt. To prevent such a problem, paper dust collected in the paper holder and paper transport section and on the surface of the thermal head must be removed periodically. Such cleaning is recommended to be carried out once six month or one million lines.

### 8-1. Cleaning the Thermal Head

To remove blackish dust collected on the surface of the thermal head, wipe it with Isopropyl alcohol (IPA).

**Note:** The thermal head is easy to damage, so clean it gently with a soft cloth. Take sufficient care not to scratch it when cleaning it.

### 8-2. Cleaning the Paper Holder

Use a soft cloth to remove paper dust from the paper holder and paper transport section.



# TABLE DES MATIERES

<b>1. Identification des pièces et nomenclature .....</b>	<b>25</b>
<b>2. Consommables et adaptateur secteur .....</b>	<b>28</b>
<b>3. Câbles de connexion et adaptateur secteur .....</b>	<b>30</b>
3-1. Câble d'interface .....	30
3-2. Raccordement d'un appareil périphérique .....	32
3-3. Connexion de l'adaptateur secteur optionnel .....	33
3-4. Mise sous tension de l'imprimante .....	34
<b>4. Panneau de commande et autres fonctions .....</b>	<b>35</b>
4-1. Panneau de commande .....	35
4-2. Erreurs .....	35
4-3. Auto-impression .....	37
<b>5. Chargement du rouleau de papier .....</b>	<b>38</b>
<b>6. Réglage du capteur de fin de rouleau .....</b>	<b>41</b>
<b>7. Prévention et correction de bourrages de papier .....</b>	<b>43</b>
7-1. Prévention des bourrages de papier .....	43
7-2. Correction de bourrages de papier .....	43
7-3. Libération d'une unité de découpage bloquée (mode coupe-papier automatique uniquement) .....	44
<b>8. Nettoyage .....</b>	<b>46</b>
8-1. Nettoyage de la tête d'impression .....	46
8-2. Nettoyage du support de papier .....	46
<b>APPENDICE .....</b>	<b>95</b>

*L'appendice n'est pas traduit.*

Pour obtenir la dernière version de ce manuel, consultez l'adresse URL suivante:  
[http://www.star-micronics.co.jp/service/frame\\_sp\\_spr\\_e.htm](http://www.star-micronics.co.jp/service/frame_sp_spr_e.htm).

# 1. Identification des pièces et nomenclature

## Modèle avec coupe-papier automatique

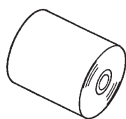
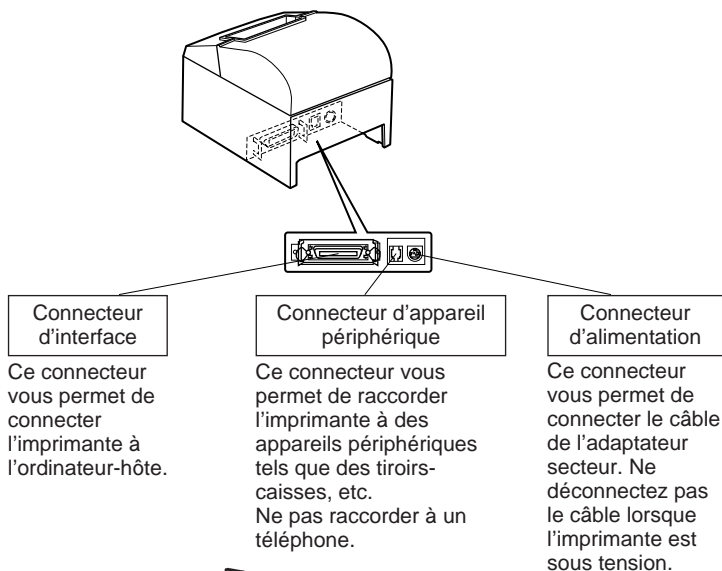
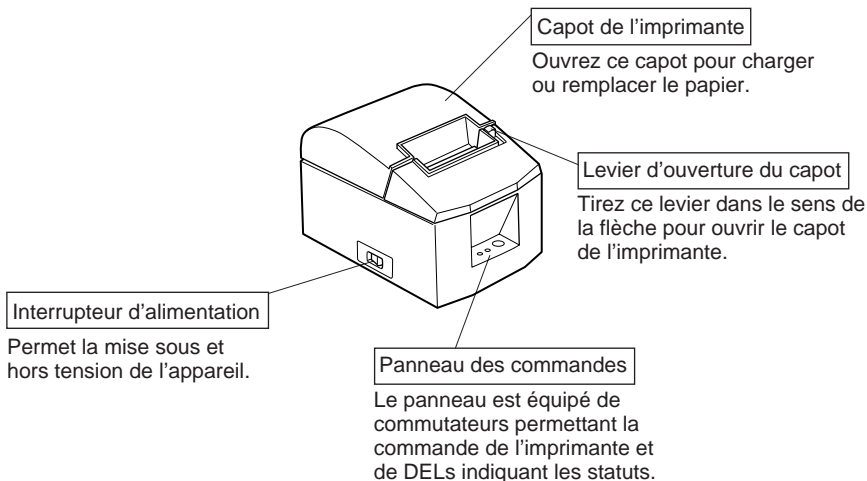

Rouleau de papier



Mode d'emploi



Tore de ferrite



Attache

(Modèle avec interface parallèle seulement) (Modèle avec interface parallèle seulement)

# Modèle avec barre de tension

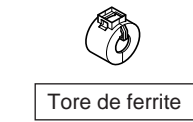
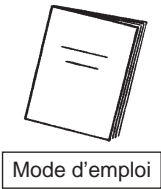
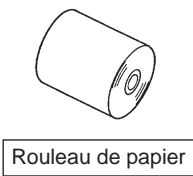
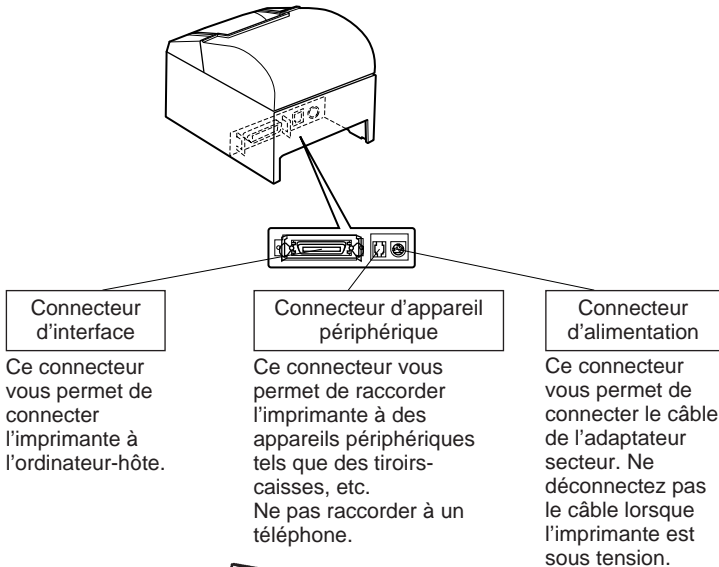
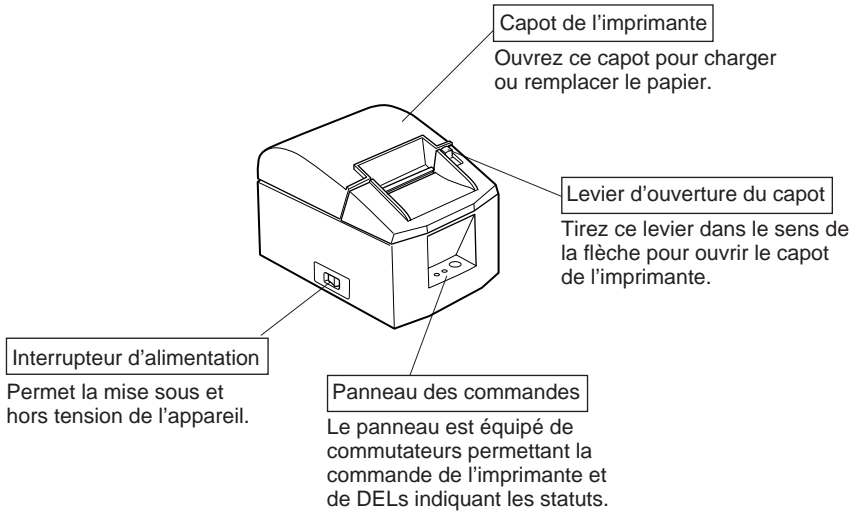

(Modèle avec interface parallèle seulement) (Modèle avec interface parallèle seulement)

## Emplacement de l'imprimante

Avant de déballer l'imprimante, déterminez l'emplacement où vous souhaitez l'installer. Veuillez observer les points ci-dessous lors de votre choix.

- ✓ Choisissez une surface stable et de niveau sur laquelle l'imprimante ne sera exposée à aucune vibration.
- ✓ Assurez-vous que l'emplacement dispose d'une prise secteur proche et d'accès aisé.
- ✓ Assurez-vous que la distance entre l'imprimante et l'ordinateur-hôte vous permet de les raccorder aisément.
- ✓ Assurez-vous que l'imprimante n'est pas exposée directement aux rayons du soleil.
- ✓ Tenez l'imprimante à l'écart des sources de chaleur importante, telles que les appareils de chauffage, etc.
- ✓ Assurez-vous que le lieu où vous souhaitez installer l'imprimante est propre, sec et n'est pas poussiéreux.
- ✓ Assurez-vous que la prise secteur à laquelle vous raccordez l'imprimante délivre une tension stable. Evitez de raccorder l'imprimante à la prise secteur d'un circuit alimentant de gros consommateurs de courant, tels qu'un photocopieur, réfrigérateur, etc.
- ✓ Assurez-vous que le lieu où vous installez l'imprimante n'est pas excessivement humide.

## 2. Consommables et adaptateur secteur

Il convient d'utiliser exclusivement les types de papier figurant dans le tableau ci-dessous. Veillez également à utiliser l'adaptateur secteur qui figure dans le tableau. L'utilisation d'un type de papier et d'adaptateur ne figurant pas dans le tableau risque d'endommager l'imprimante, de causer un incendie ou une décharge électrique.

### (1) Rouleau de papier, caractéristiques

Papier thermique

Épaisseur: 65~85  $\mu\text{m}$

Largeur: 79,5 $\pm$ 0,5 mm (57,5 $\pm$ 0,5 mm quand le support de papier en option est utilisé)

Diamètre extérieur du rouleau:  $\varnothing$ 90 mm or less

Largeur du rouleau de papier: 80 $^{+0,5}_{-1}$  mm (58 $^{+0,5}_{-1}$  mm quand le support de papier en option est utilisé)

Diamètre extérieur/intérieur du support de rouleau

Épaisseur du papier	Extérieur du support de rouleau	Intérieur du support de rouleau
65~85 $\mu\text{m}$	$\varnothing$ 18 $\pm$ 1 mm	$\varnothing$ 12 $\pm$ 1 mm

Surface imprimée: Bord extérieur du rouleau

Extrémité arrière: Ne pas utiliser de colle pour immobiliser le rouleau de papier ou son noyau.

Ne pas plier l'extrémité arrière du papier.

### (2) Papier conseillé

Mitsubishi paper mills limited

P220AG (papier de type normal), 65  $\mu\text{m}$  (épaisseur)

HP220A (papier à stabilité d'image élevée), 65  $\mu\text{m}$  (épaisseur)

HP220AB-1 (papier à stabilité d'image élevée), 75  $\mu\text{m}$  (épaisseur)

P220AB (papier de type normal, ticket), 85  $\mu\text{m}$  (épaisseur)

Oji paper Co., Ltd.

PD150R (papier de type normal), 75  $\mu\text{m}$  (épaisseur)

PD160R (papier à stabilité d'image élevée), 65/75  $\mu\text{m}$  (épaisseur)

Nippon paper industries

TF50KS-E2C (papier de type normal), 65  $\mu\text{m}$  (épaisseur)

Suivant le type et l'épaisseur du papier, il peut être nécessaire de changer le réglage de clarté d'impression. Pour changer le réglage de la clarté d'impression, utilisez la commande de réglage de clarté d'impression <ESC><RS>'d'n. Reportez-vous au manuel de programmation séparé pour les détails.

(3) Adaptateur secteur (option)

Nom du modèle: PS60-24 A

Entrée: CA100 à 240 V, 50/60 Hz

Sortie: CC24±5%, 2,0 A (charge de 10 sec à 5,0 A max.)

---

**Attention!**

*Pour obtenir des informations concernant le papier recommandé, consultez l'adresse URL suivante : <http://www.star-micronics.co.jp/>.*

---



## 3. Câbles de connexion et adaptateur secteur

### 3-1. Câble d'interface

#### 3-1-1. Installation du tore de ferrite (modèle avec interface parallèle seulement)

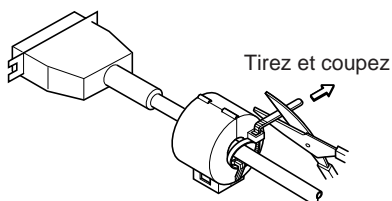
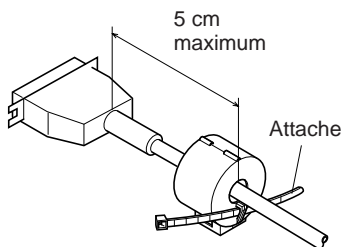
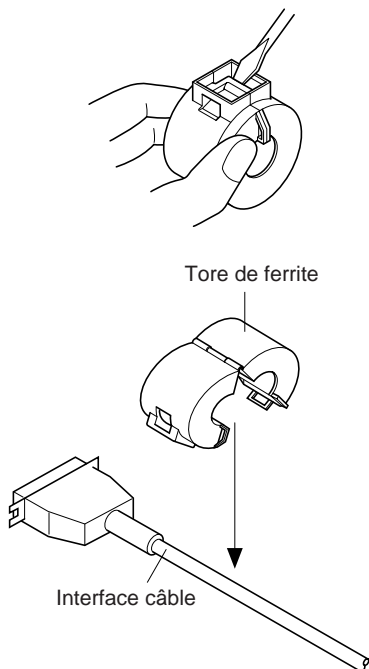

(1) Modèle avec interface parallèle seulement: fixez la grande gaine en ferrite sur le câble comme illustré.

(2) Passez l'attache dans le tore de ferrite.

(3) Passez l'attache autour du tore de ferrite et serrez-la. Coupez l'extrémité de l'attache à l'aide de ciseaux.

### 3-1-2. Connexion du câble d'interface

**Remarque:** Avant de connecter ou déconnecter le câble d'interface, veillez à ce que l'imprimante et tous les appareils qui y sont connectés soient hors tension.

**Veillez également à débrancher le câble d'alimentation de la prise secteur.**

- (1) Connectez le câble d'interface à la borne figurant sur le panneau arrière de l'imprimante.
- (2) Dans le cas d'une interface série, resserrez les vis du connecteur. Dans le cas d'une interface parallèle, fixez le connecteur avec les fermoirs.

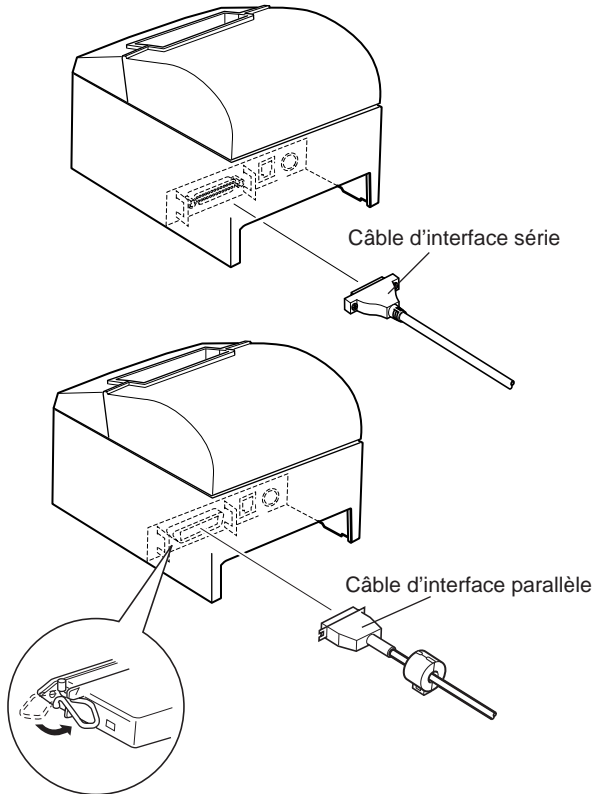

## 3-2. Raccordement d'un appareil périphérique

Vous pouvez raccorder un appareil périphérique à l'imprimante à l'aide d'une fiche modulaire. Nous expliquons ci-dessous comment installer le tore de ferrite et faire le raccordement proprement dit. Pour les détails sur le type de fiche modulaire à utiliser, reportez-vous à la page 108. Notez que le fil ou la fiche modulaires ne sont pas fournis avec l'imprimante. Vous devrez donc vous les procurer.

---

### **Attention!**

*Assurez-vous que l'imprimante est hors tension, qu'elle est débranchée de la prise secteur et que l'ordinateur est hors tension avant d'effectuer les connexions.*

---

- (1) Connectez le câble de pilote de périphérique à la borne figurant sur le panneau arrière de l'imprimante.
- 

### **Attention!**

*Ne connectez pas une ligne de téléphone à la borne du pilote de périphérique, sous peine de risquer d'endommager l'imprimante. Pour des raisons de sécurité, il convient également de ne pas brancher d'appareil périphérique en cas de risque de survoltage.*

---

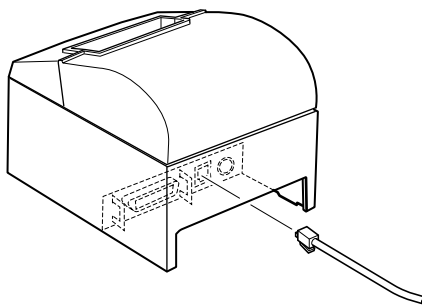

### 3-3. Connexion de l'adaptateur secteur optionnel

**Remarque:** Avant de connecter ou déconnecter l'adaptateur secteur, veillez à ce que l'imprimante et tous les appareils qui y sont connectés soient hors tension. Veillez également à débrancher le câble d'alimentation de la prise secteur.

(1) Connectez l'adaptateur secteur au câble d'alimentation.

**Remarque:** Utilisez exclusivement l'adaptateur secteur et le câble d'alimentation destinés à l'imprimante.

(2) Connectez l'adaptateur secteur à la borne de l'imprimante.

(3) Branchez la prise du câble d'alimentation à la prise secteur.

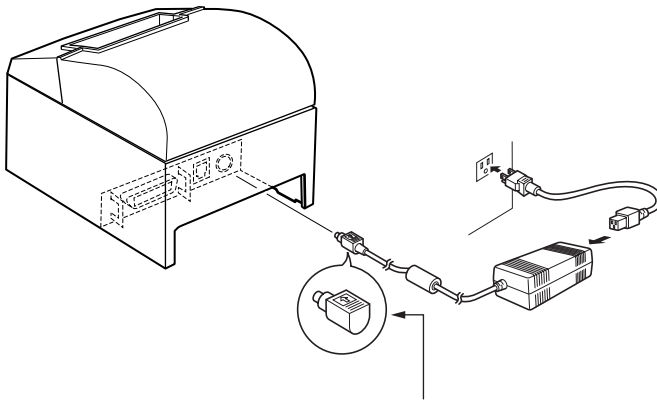

---

#### **Attention!**

Lorsque vous débranchez le câble, saisissez la prise du câble pour tirer dessus. Vous pourrez débrancher plus facilement la prise après avoir libéré le verrou. Ne tirez pas violemment sur le câble car vous risqueriez d'endommager la prise.

---

### 3-4. Mise sous tension de l'imprimante

Assurez-vous d'avoir bien connecté l'adaptateur secteur comme décrit à la section 3-3.

(1) Placez l'interrupteur d'alimentation, situé à l'avant de l'imprimante, sur la position sous tension.

La DEL POWER s'allume au panneau des commandes.

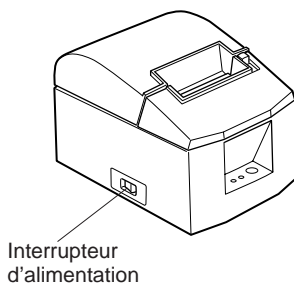

---

#### **Attention!**

*Nous vous recommandons de débrancher l'imprimante du secteur lorsque vous ne comptez pas l'utiliser pendant une période prolongée. Par ailleurs, veuillez lors de l'installation à ce que la prise secteur alimentant l'imprimante soit proche et d'accès facile.*

---

# 4. Panneau de commande et autres fonctions

## 4-1. Panneau de commande

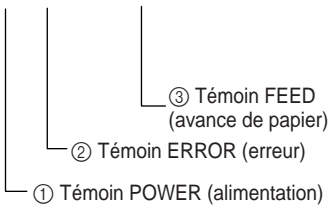
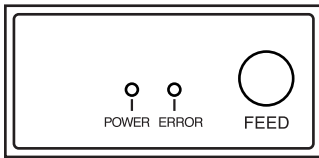

- ① Témoin POWER (DEL verte)  
S'allume quand l'appareil est sous tension.
- ② Témoin ERROR (DEL rouge)  
Indique des erreurs variées en combinaison avec le témoin POWER.
- ③ Témoin FEED  
Appuyez sur la touche FEED pour faire avancer le papier.

## 4-2. Erreurs

### 1) Erreur récupérable automatiquement

Description de l'erreur	Témoin POWER	Témoin ERROR	Conditions de récupération
Détection de température élevée de la tête	Clignote à 0,5 seconde d'intervalle	Hors tension	Récupération automatique après refroidissement de la tête.
Erreur d'ouverture du capot de l'imprimante	Sous tension	Sous tension	Récupération automatique après fermeture du capot de l'imprimante.

### 2) Erreur non récupérable

Description de l'erreur	Témoin POWER	Témoin ERROR	Conditions de récupération
Erreur de mémoire vive	Hors tension	Sous tension	Ce n'est pas une erreur récupérable. Consultez votre revendeur pour des réparations.
Erreur de protection de mémoire	Clignote à 0,25 seconde d'intervalle	Clignote à 0,25 seconde d'intervalle	Ce n'est pas une erreur récupérable. Consultez votre revendeur pour des réparations.
Erreur de thermistor	Clignote à 0,5 seconde d'intervalle	Clignote à 0,5 seconde d'intervalle	Ce n'est pas une erreur récupérable. Consultez votre revendeur pour des réparations.
Erreur d'alimentation	Clignote à 1 seconde d'intervalle	Clignote à 1 seconde d'intervalle	Ce n'est pas une erreur récupérable. Consultez votre revendeur pour des réparations.

### Remarque

- 1) Si une erreur non récupérable se produit, mettez immédiatement l'appareil hors tension.
- 2) Quand une erreur d'alimentation se produit, il est possible que le bloc d'alimentation soit en panne. Pour d'autres erreurs non récupérables, veuillez consulter votre revendeur pour des réparations.

### 3) Erreur de découpe du papier

Description de l'erreur	Témoin POWER	Témoin ERROR	Conditions de récupération
Erreur de découpe du papier	Hors tension	Clignote à 0,125 seconde d'intervalle	Récupération si l'unité de découpage revient dans sa position d'origine après la mise hors tension et sous tension. La restauration n'est pas possible avec la commande <DEL> <ENQ> dans le mode ESC/POS.

#### Remarque

- 1) Si l'unité de découpage ne revient pas dans sa position d'origine ou n'effectue pas le mouvement initial, la récupération est impossible.
- 2) Si le papier est coincé, mettez l'appareil hors tension, dégagez le bourrage de papier, puis mettez l'appareil sous tension.
- 3) Erreurs de coupure de papier dans le statut de l'imprimante.  
Mode STAR: Erreur irrécupérable  
Mode ESC/POS: Erreur récupérable

### 4) Erreur de détection de papier

Description de l'erreur	Témoin POWER	Témoin ERROR	Conditions de récupération
Erreur de sortie de papier	Sous tension	Clignote à 0,5 seconde d'intervalle	Récupération automatique après chargement d'un nouveau rouleau de papier et fermeture du capot de l'imprimante.
Le rouleau de papier est presque terminé	Sous tension	Clignote à 2 seconde d'intervalle	Les indicateurs signalent la fin proche du rouleau, mais l'imprimante continue à imprimer.





## 5. Chargement du rouleau de papier

Veillez à utiliser un rouleau de papier qui correspond aux spécifications de l'imprimante.

Lors de l'utilisation d'un rouleau de papier de 57,5 mm de large, chargez le rouleau de papier comme indiqué à la page suivante.

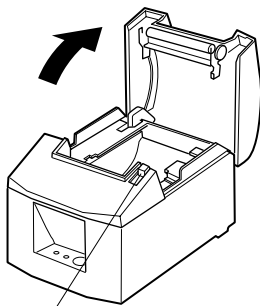

Levier d'ouverture du capot

Rouleau de papier

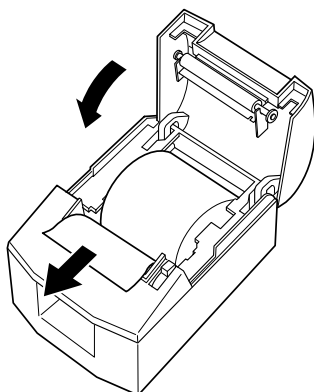
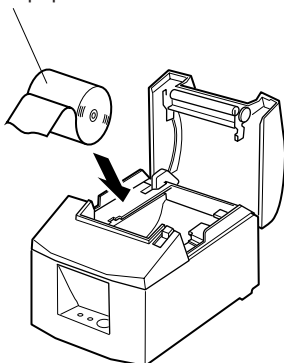

- 1) Poussez le levier d'ouverture du capot et ouvrez le capot de l'imprimante.

- 2) Mettez le rouleau de papier en place dans le creux tout en respectant son orientation, et tirez sur l'extrémité du papier.

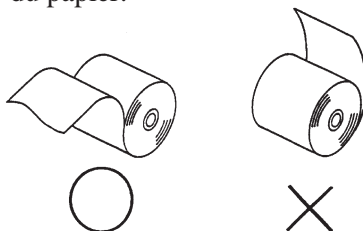

Support du rouleau de papier

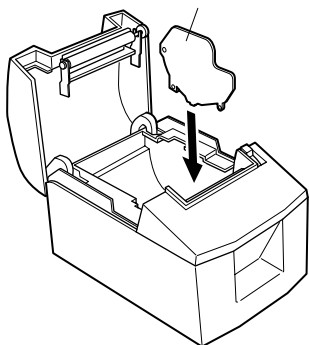

**Remarque:** Lors de l'utilisation d'un rouleau de papier de 57,5 mm de large, installez le support de papier dans le logement prévu dans l'imprimante.

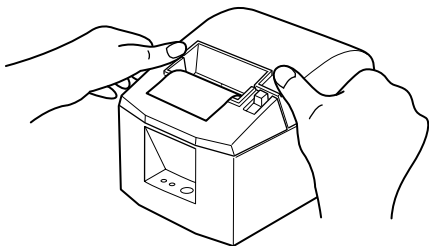

3) Poussez vers la bas les deux côtés du capot de l'imprimante pour le fermer.

**Remarque:** Assurez-vous que le capot de l'imprimante est bien fermé.

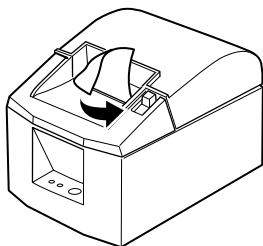

**Modèle avec barre de tension**

4) **Modèle avec barre de tension:**

Déchirez le papier comme illustré.

**Modèle avec coupe-papier automatique:**

Si le couvercle de l'imprimante est fermé après la mise sous tension, le coupe-papier coupe automatiquement la partie avant du papier.

---

**Attention!**

1. *Ne pas toucher la lame du coupe-ruban.*
    - *Une lame se trouve dans la fente de sortie de papier. Il est fortement déconseillé de mettre sa main dans la fente de sortie de papier non seulement pendant l'impression mais aussi en toute autre circonstance, même quand l'impression n'est pas effectuée.*
    - *Le capot de l'imprimante peut être ouvert pour remplacer le papier. Néanmoins, la lame du coupe-ruban se trouvant à l'intérieur du capot de l'imprimante, veuillez faire attention à ne pas rapprocher votre figure ou vos mains trop près de la lame du coupe-ruban.*
  2. *Ne tirez pas le levier d'ouverture du couvercle et n'ouvrez pas le couvercle pendant l'impression ou pendant le fonctionnement du coupe-papier.*
  3. *Ne pas faire fonctionner le levier d'ouverture du capot tout en appuyant sur le capot de l'imprimante avec la main.*
  4. *Ne pas tirer sur le papier pour le faire sortir quand le capot de l'imprimante est fermé.*
  5. *L'élément de chauffage et le circuit imprimé de la tête d'impression thermique sont facilement endommagés. Ne pas les toucher avec des objets métalliques, du papier de verre, etc.*
  6. *Pendant et immédiatement après l'impression, la zone autour de la tête d'impression thermique est très chaude. Ne pas la toucher car vous pourriez vous brûler.*
  7. *La qualité d'impression peut être affectée si l'élément de chauffage de la tête d'impression thermique est souillé par un contact avec vos mains, Ne pas toucher l'élément de chauffage de la tête d'impression thermique.*
  8. *Le circuit imprimé de la tête d'impression thermique peut être endommagé par l'électricité statique. Ne touchez jamais directement le circuit imprimé.*
  9. *La qualité d'impression et la durée de vie utile de la tête d'impression thermique ne peuvent pas être garanties si un papier quelconque différent de celui recommandé est utilisé. En particulier, le papier contenant les éléments suivants: NA+, K+, C1-, peut réduire de façon importante la durée de vie utile de la tête d'impression thermique. Veuillez prendre des précautions.*
  10. *Ne pas faire fonctionner l'imprimante si de l'humidité provenant de la condensation, etc., est présente sur la surface avant de la tête.*
-

## 6. Réglage du capteur de fin de rouleau

Utilisez la procédure suivante pour régler le capteur de fin de rouleau conformément à la taille du rouleau de papier utilisé.

- ① Ouvrez le capot de l'imprimante.
- ② Déterminez le diamètre du rouleau de papier utilisé et identifiez le réglage requis dans le tableau ci-dessous.
- ③ Insérez la pointe d'un stylo à bille ou d'un instrument similaire dans le trou du curseur de réglage, puis tout en appuyant sur le curseur de réglage, faites-le glisser jusqu'à la position souhaitée.

Lorsque vous changez le réglage, assurez-vous que le trou est bien aligné sur le repère d'alignement indiqué par la flèche.

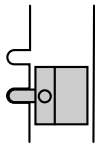
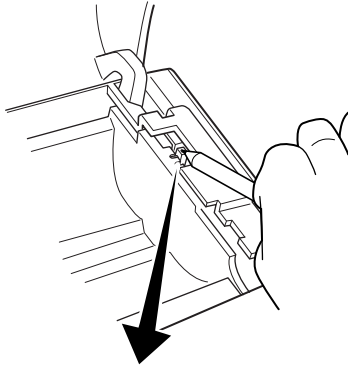

(Niveau 1)

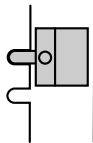

(Niveau 2)

Valeur de réglage correspondant au papier utilisé.

Épaisseur du papier ( $\mu\text{m}$ )	Quand vous utilisez un rouleau de papier dont le diamètre intérieur du support est de (A): $\phi 12$ et le diamètre extérieur de (B): $\phi 18$			
	Diamètre détecté (C) (Env. mm)		Longueur de papier restante (Env. m)	
	Niveau 1	Niveau 2	Niveau 1	Niveau 2
65	$\phi 23$	$\phi 31$	2,7	7,3
85	$\phi 21$		1,2	5,5

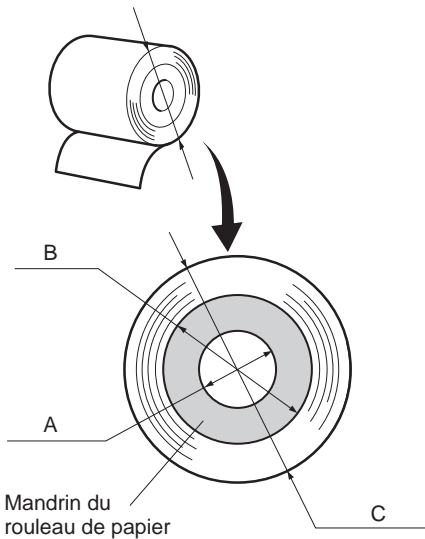

### Remarque

- 1) Le curseur de réglage du modèle standard est réglé sur le niveau 1 en usine.
- 2) La dimension C et la longueur de papier restante sont les valeurs calculées. Il est possible qu'il y ait quelques différences dans le mécanisme actuel.
- 3) Il est conseillé d'utiliser le niveau 2, car le papier peut se détendre, ce qui entraînera une disproportion entre les dimensions C et la longueur de papier restante, lorsqu'une épaisseur de papier de  $85 \mu\text{m}$  est utilisée.

## 7. Prévention et correction de bourrages de papier

### 7-1. Prévention des bourrages de papier

Il convient de ne jamais toucher le papier pendant son éjection et avant qu'il soit coupé. Appuyer ou tirer sur le papier pendant son éjection risque de provoquer un bourrage, des problèmes de coupure ou d'avance de ligne.

### 7-2. Correction de bourrages de papier

En cas de bourrage de papier, procédez comme suit afin d'y remédier :

(1) Mettez l'appareil hors tension.

(2) Tirez le levier tout à fait vers le bas afin d'ouvrir le capot de l'imprimante. Si le couvercle de l'imprimante ne s'ouvre pas sur les modèles à coupe-papier automatique, c'est que celui-ci n'est pas à sa position d'origine. Dans ce cas, ramenez le coupe-papier à sa position d'origine en suivant les instructions de la section 7-3. Ouvre le couvercle de l'imprimante lorsque le papier coincé a été retiré.

(3) Retirez le papier bloqué.

**Remarque:** Veillez à ne pas endommager l'imprimante lors du retrait du papier bloqué.

Veillez particulièrement à ne pas toucher la tête d'impression thermique en raison de sa fragilité.

(4) Veillez à insérer le rouleau de papier tout droit et refermez avec soin le capot de l'imprimante.

**Remarque 1:** Le papier doit être placé bien droit. Si vous refermez le capot de l'imprimante alors que le papier est de travers (voir illustration), un bourrage peut se produire.

**Remarque 2:** Verrouillez le capot de l'imprimante en appuyant sur les côtés. Ne pas essayer de refermer le capot en appuyant sur son centre. Le capot pourrait ne pas se verrouiller correctement.

(5) Mettez l'imprimante sous tension. Assurez-vous que la DEL ERROR n'est pas allumée.

**Remarque:** Tant que la DEL ERROR est allumée, l'imprimante n'accepte aucune commande. Il faut donc veiller à ce que le capot de l'imprimante soit verrouillé.

### 7-3. Libération d'une unité de découpage bloquée (mode coupe-papier automatique uniquement)

Si l'unité de découpage automatique se bloque ou ne coupe pas le papier, suivez les étapes ci-dessous.

---

#### **Attention**

*Le travail sur l'unité de découpage étant dangereux, n'oubliez pas de mettre avant tout l'imprimante hors tension.*

---

- (1) Réglez l'interrupteur d'alimentation sur la position hors tension OFF pour mettre l'imprimante hors tension.
- (2) Faites glisser le couvercle avant pour dégager l'unité de découpage automatique.
- (3) Enlevez le papier coincé.

**Remarque:** Faites attention à ne pas endommager l'imprimante pendant que vous enlevez le papier coincé.

La tête d'impression thermique étant particulièrement sensible, veillez à ne pas la toucher.

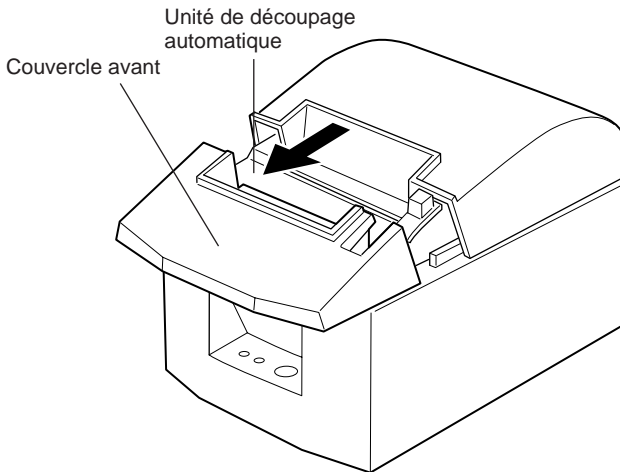

(4) Si la lame mobile de l'unité de découpage dépasse, utilisez un tournevis cruciforme pour tourner la vis cruciforme et ramener la lame dans sa position d'origine.

Quand la fenêtre de contrôle est complètement blanche, la lame mobile est dans sa position d'origine.

**Remarque 1:** N'appliquez pas de pression excessive sur la lame mobile.

**Remarque 2:** Si la lame mobile dépasse trop, le capot de l'imprimante ne pourra pas être ouvert. Vous risquez d'endommager l'unité de découpage automatique en essayant d'ouvrir le capot de l'imprimante.

(5) Ouvrez le capot de l'imprimante, enlevez le papier coincé, puis remettez le rouleau de papier en place.

(6) Installez le couvercle avant, puis réglez l'interrupteur d'alimentation sur la position sous tension.

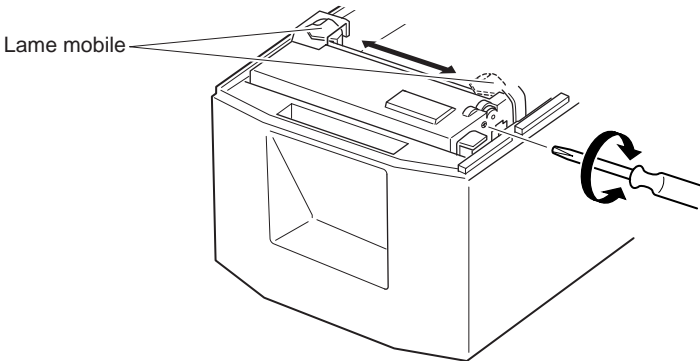



## 8. Nettoyage

Les caractères imprimés pourraient devenir partiellement illisibles en raison de l'accumulation de la poussière de papier et de crasse. Afin de prévenir ce genre de problème, il convient de nettoyer régulièrement la poussière qui s'accumule sur le support de papier, les passages du papier et la surface de la tête d'impression. Il est recommandé d'effectuer un tel nettoyage une fois tous les six mois ou après l'impression d'un million de lignes.

### 8-1. Nettoyage de la tête d'impression

Nettoyez la poussière noirâtre accumulée sur la surface de la tête d'impression thermique en l'essuyant avec de l'alcool isopropylique.

**Remarque:** La tête d'impression thermique est fragile, il convient donc de procéder avec précaution. Prenez soin de ne pas la griffer.

### 8-2. Nettoyage du support de papier

Nettoyez la poussière de papier accumulée sur le support de papier et sur les passages du papier à l'aide d'un chiffon doux.



# INHALTSVERZEICHNIS

<b>1. Beschreibung und Bezeichnung der Geräteteile .....</b>	<b>49</b>
<b>2. Verbrauchsteile und Netzteil .....</b>	<b>52</b>
<b>3. Anschlußkabel und Netzteil .....</b>	<b>54</b>
3-1. Schnittstellenkabel .....	54
3-2. Anschluß an ein Peripheriegerät .....	56
3-3. Anschließen des optionalen Netzteils .....	57
3-4. Einschalten .....	58
<b>4. Bedienfeld und andere Funktionen .....</b>	<b>59</b>
4-1. Bedienfeld .....	59
4-2. Fehler .....	59
4-3. Selbstdruck .....	61
<b>5. Einlegen der Papierrolle .....</b>	<b>62</b>
<b>6. Einstellung des Endanäherungs-Sensors .....</b>	<b>65</b>
<b>7. Verhindern und Beheben von Papierstau .....</b>	<b>67</b>
7-1. Verhindern von Papierstau .....	67
7-2. Beheben von Papierstau .....	67
7-3. Freigeben eines gesperrten Schneidmessers (Nur Auto-Schneidwerkmodell) .....	68
<b>8. Regelmäßige Reinigung .....</b>	<b>70</b>
8-1. Reinigen des Thermalkopfes .....	70
8-2. Reinigen des Papierhalters .....	70
<b>ANHANG .....</b>	<b>95</b>

*Der Anhang dieser Bedienungsanleitung ist nur in englischer Sprache.*

Bitte wenden Sie sich an die folgende Internet-Address:  
[http://www.star-micronics.co.jp/service/frame\\_sp\\_spr\\_e.htm](http://www.star-micronics.co.jp/service/frame_sp_spr_e.htm),  
wenn Sie die neueste Revision dieses Handbuchs lesen möchten.

# 1. Beschreibung und Bezeichnung der Geräteteile

## Auto-Schneidwerkmodell

DEUTSCH

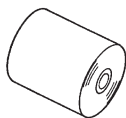
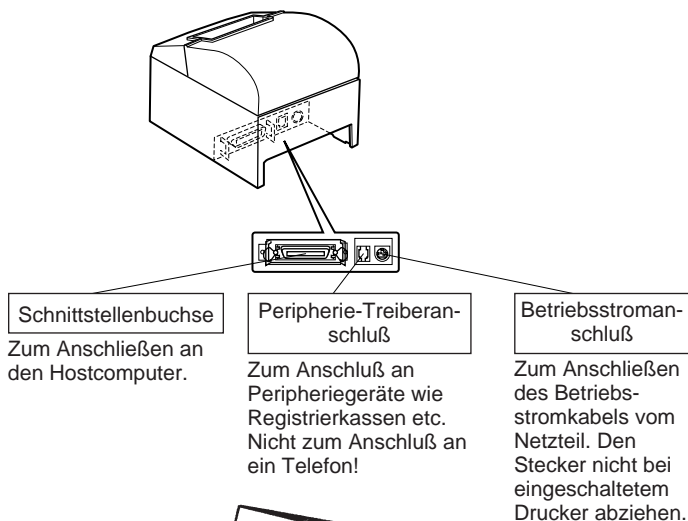
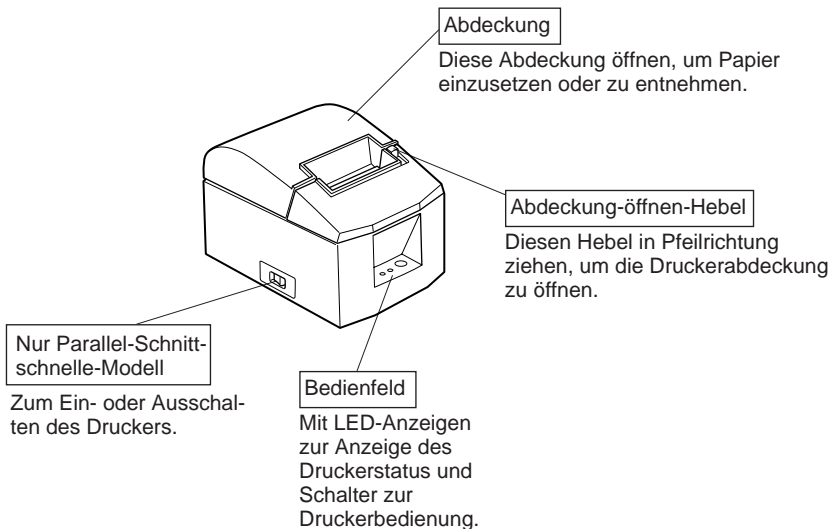

Rollenpapier



Bedienungsanleitung



Ferritkern



Befestigungsband

(Nur beim Parallel-Schnittschnelle-Modell) (Nur beim Parallel-Schnittschnelle-Modell)

# Abreißkantenmodell

DEUTSCH

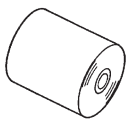
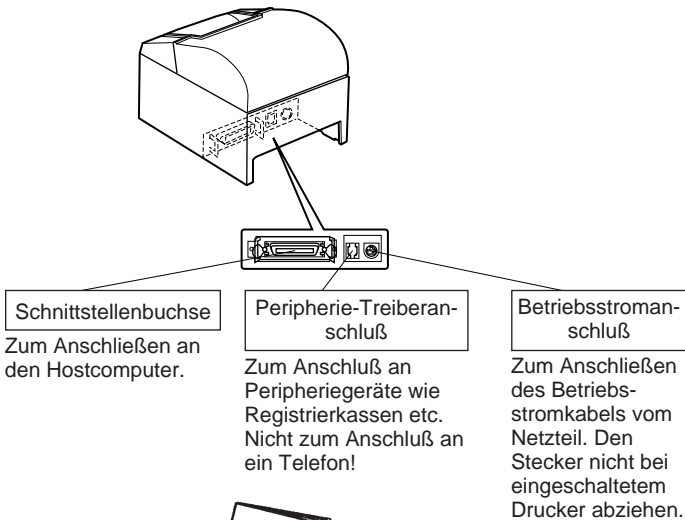
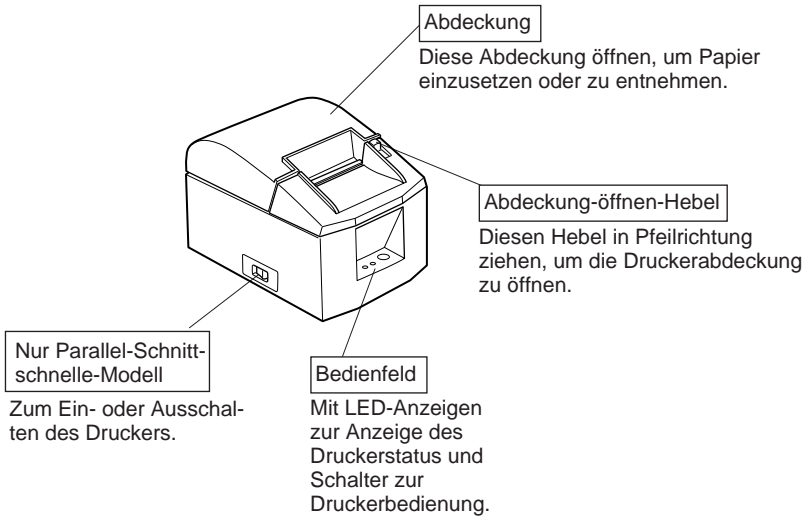

**Rollenpapier**



**Bedienungsanleitung**



**Ferritkern**



**Befestigungsband**

(Nur beim Parallel-Schnittschnelle-Modell) (Nur beim Parallel-Schnittschnelle-Modell)

## Wahl eines Aufstellungsorts für den Drucker

Bevor Sie den Drucker auspacken, sollten Sie einige Minuten damit verbringen, einen geeigneten Aufstellungsort auszusuchen. Denken Sie dabei an die folgenden Punkte:

- ✓ Den Drucker auf einem flachen, aber festen Untergrund aufstellen, wo keine Vibrationen vorhanden sind.
- ✓ Die verwendete Steckdose soll in der Nähe und frei zugänglich sein.
- ✓ Sicherstellen, daß der Drucker nahe genug am Computer ist, um die Geräte mit dem Druckerkabel verbinden zu können.
- ✓ Sicherstellen, daß der Drucker vor direktem Sonnenlicht geschützt ist.
- ✓ Sicherstellen, daß der Drucker ausreichend weit von Heizkörpern entfernt steht.
- ✓ Dafür sorgen, daß die Umgebung des Druckers sauber, trocken und staubfrei ist.
- ✓ Sicherstellen, daß der Drucker an eine einwandfreie Stromzufuhr angeschlossen ist. Er sollte nicht an Steckdosen angeschlossen werden, an denen bereits Geräte mit möglichen Netzstörungen wie Kopierer, Kühlschränke u.a. angeschlossen sind.
- ✓ Den Drucker nicht an Orten mit hoher Luftfeuchtigkeit aufstellen.

## 2. Verbrauchsteile und Netzteil

Wenn die Verbrauchsteile verbraucht sind, besorgen Sie Ersatz entsprechend der unten gezeigten Tabelle.

Verwendung von Verbrauchsteilen oder Netzteilen, die nicht den unten aufgeführten Beschreibungen entsprechend, kann zu Schäden am Drucker, Bränden oder elektrischen Schlägen führen.

### (1) Rollenpapierbeschreibung

Thermopapier

Dicke: 65~85  $\mu\text{m}$

Breite: 79,5 $\pm$ 0,5 mm (57,5 $\pm$ 0,5 mm wenn der optionale Papierrollenhalter verwendet wird)

Rollen-Außendurchmesser:  $\varnothing$ 90 mm or less

Breite der Aufnehmerpapierrolle: 80 $^{+0,5}_{-1}$  mm (58 $^{+0,5}_{-1}$  mm wenn der optionale Papierrollenhalter verwendet wird)

Kern Außen/Innen-Durchmesser

**Papierdicke**

65~85  $\mu\text{m}$

**Kern außen**

$\varnothing$ 18 $\pm$ 1 mm

**Kern innen**

$\varnothing$ 12 $\pm$ 1 mm

Druckfläche: Äußere Papierkante

Behandlung der Papierendkante: Nicht Paste oder Kleber zum Befestigen von Papierrolle oder Kern verwenden.

Nicht die Papierendkante falten.

### (2) Empfohlenes Papier

Mitsubishi Paper Mills Ltd.

P220AG (Normalpapier), 65  $\mu\text{m}$  (Dicke)

HP220A (Papier für hochstabile Bilder), 65  $\mu\text{m}$  (Dicke)

HP220AB-1 (Papier für hochstabile Bilder), 75  $\mu\text{m}$  (Dicke)

P220AB (Normalpapier, Kartenticket), 85  $\mu\text{m}$  (Dicke)

Oji Paper Co., Ltd.

PD150R (Normalpapier), 75  $\mu\text{m}$  (Dicke)

PD160R (Papier für hochstabile Bilder), 65/75  $\mu\text{m}$  (Dicke)

Nippon Paper Industries

TF50KS-E2C (Normalpapier), 65  $\mu\text{m}$  (Dicke)

Je nach Typ und Stärke des Papiers kann es erforderlich sein, die Einstellungen für die Druckintensität zu ändern. Zum Ändern der Intensitätseinstellung den Druckintensität-Befehle <ESC><RS>'d'n verwenden. Einzelheiten siehe Programmieranleitung.

(3) Netzteil (Option)

Modelbezeichnung: PS60-24 A

Eingang: 100 bis 240 V WS, 50/60 Hz

Ausgang: 24 V GS±5%, max. 2,0 A (max. 10 s bei 5,0 A Last)

---

**Wichtig!**

*Empfehlungen zu den zu verwendenden Papiersorten sind im Internet bei der folgenden URL erhältlich: <http://www.star-micronics.co.jp/>*

---



## 3. Anschlußkabel und Netzteil

### 3-1. Schnittstellenkabel

#### 3-1-1. Anbringen des Ferritkerns (Nur beim Parallel-Schnittschnelle-Modell)

- (1) Nur beim Parallel-Schnittschnelle-Modell, Befestigen Sie den großen Ferritkern am Kabel, wie das in der folgenden Abbildung gezeigt wird.

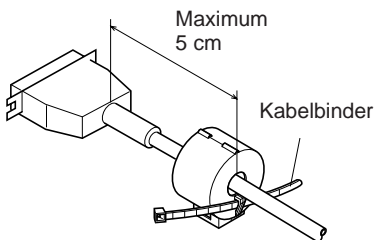
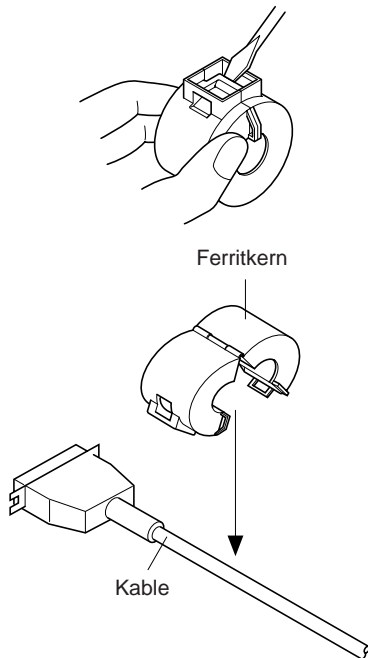

- (2) Führen Sie den Kabelbinder durch den Ferritkern.

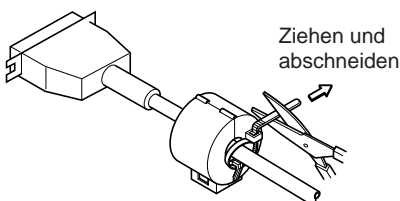

- (3) Führen Sie den Kabelbinder um das Kabel und sperren Sie ihn. Schneiden Sie überschüssiges Band mit einer Schere ab.

## 3-1-2. Anschließen des Schnittstellenkabels

**Hinweis:** Vor dem Anschließen/Abtrennen des Schnittstellenkabels stellen Sie sicher, daß der Drucker und alle angeschlossenen Gerät ausgeschaltet sind.

**Außerdem sollte der Netzstecker abgezogen sein.**

- (1) Schließen Sie das Schnittstellenkabel an die Buchse an der Rückseite des Druckers an.
- (2) Bei einer seriellen Schnittstelle ziehen Sie die Steckererschrauben fest. Bei einer parallelen Schnittstelle befestigen Sie die Steckerklammern.

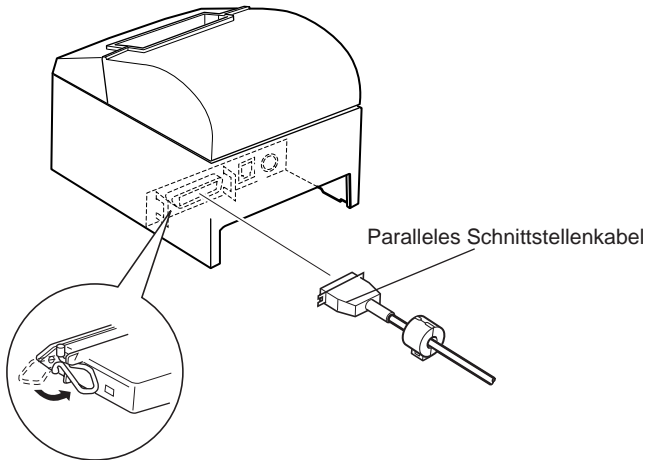
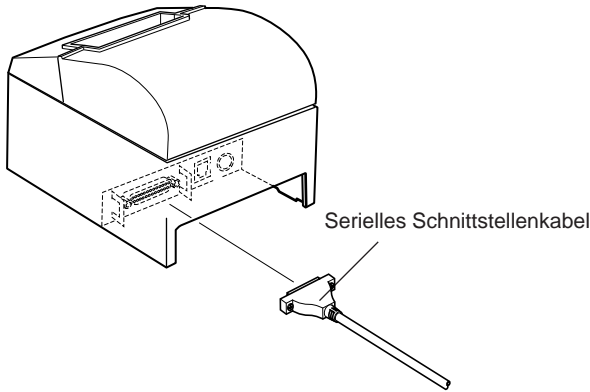

## 3-2. Anschluß an ein Peripheriegerät

Es kann ein Peripheriegerät an den Drucker mit einem Modularstecker angeschlossen werden. Im folgenden wird beschrieben, wie der Ferritkern angebracht und die Verbindung hergestellt wird. Siehe "Modularstecker" auf Seite 108 für den Typ von Modularstecker, der dazu erforderlich ist. Beachten Sie, daß der Drucker nicht mit einem Modularstecker oder Kabel ausgestattet ist. Diese Teile müssen vom Anwender besorgt werden.

---

### **Wichtig!**

*Vor dem Anschließen der Kabel sicherstellen, daß der Drucker ausgeschaltet und vom Netz getrennt ist.*

---

- (1) Schließen Sie das Peripheriegeräte­kabel an die Buchse an der Rückseite des Druckers an.
- 

### **Wichtig!**

*Nicht eine Telefonleitung an die Peripheriebuchse anschließen. Wenn dies geschieht, besteht die Gefahr von Schäden am Drucker. Aus Sicherheitsgründen außerdem nicht Verdrahtung an die Peripheriebuchse anschließen, wenn die Möglichkeit besteht, daß zu starke Spannung anliegt.*

---

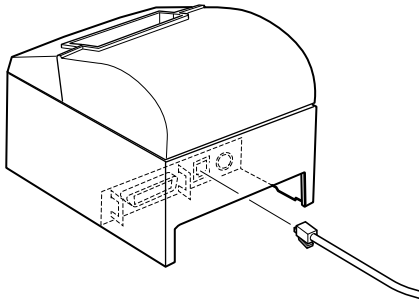

### 3-3. Anschließen des optionalen Netzteils

**Hinweis:** Vor dem Anschließen/Abtrennen des Netzteils stellen Sie sicher, daß der Drucker und alle angeschlossenen Gerät ausgeschaltet sind. Außerdem sollte der Netzstecker abgezogen sein.

(1) Schließen Sie das Netzteil an das Netzkabel an.

**Hinweis:** Verwenden Sie nur das vorgesehene Netzteil und Netzkabel.

(2) Das Netzteil am Stecker des Druckers anschließen.

(3) Stecken Sie den Netzstecker des Netzteils in eine Steckdose ein.

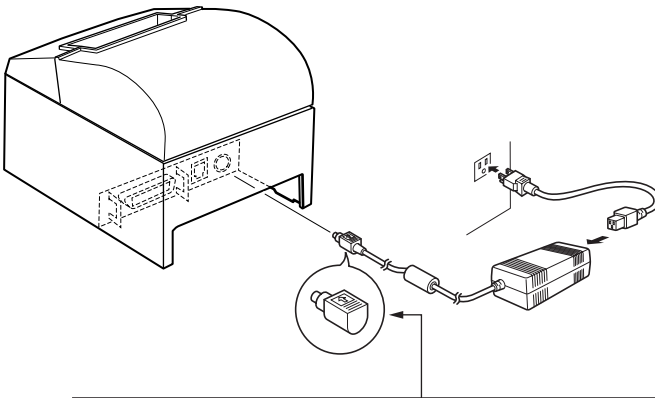

---

#### **Wichtig!**

Beim Abziehen des Kabels immer am Stecker ziehen und nicht am Kabel. Durch das Lösen der Verriegelung wird das Abziehen des Steckers leicht möglich.

Wenn stark am Kabel selber gezogen wird, kann der Stecker beschädigt werden.

---

### 3-4. Einschalten

Stellen Sie sicher, daß das Netzteil angeschlossen ist, wie in 3-3 beschrieben.

- (1) Den Netzschalter vorne am Gerät auf Ein (ON) stellen. Das POWER-Lämpchen am Bedienfeld leuchtet auf.

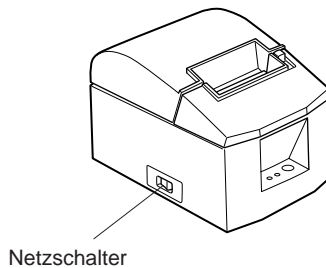

---

#### **Wichtig!**

*Wir empfehlen, den Netzstecker aus der Steckdose zu ziehen, wenn der Drucker längere Zeit lang nicht benutzt werden soll. Der Drucker sollte vorzugsweise an einem Platz aufgestellt werden, der leichten Zugang zur Netzsteckdose gewährt.*

---

# 4. Bedienfeld und andere Funktionen

## 4-1. Bedienfeld

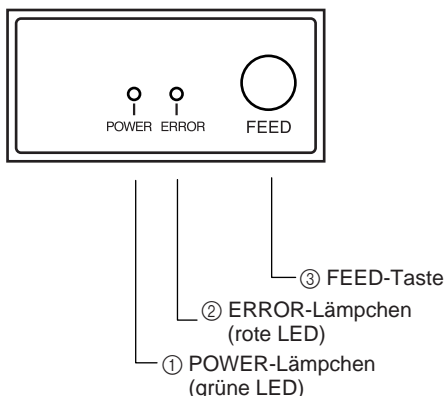

- ① POWER-Lämpchen (grüne LED)  
Leuchtet in eingeschaltetem Zustand
- ② ERROR-Lämpchen (rote LED)  
Zeigt in Kombination mit dem POWER-Lämpchen verschiedene Fehlerzustände an
- ③ FEED-Taste  
Die FEED-Taste drücken, um das Rollenpapier vorzutransportieren.

## 4-2. Fehler

### 1) Automatisch behebbare Fehler

Fehlerbeschreibung	POWER-Lämpchen	ERROR-Lämpchen	Behebungsbedingungen
Erkennung hoher Kopf-temperatur	Blinkt in Abständen von 0,5 s	Aus	Automatische Behebung nach Abkühlen des Druckkopfes.
Abdeckung-Offen-Fehler	Ein	Ein	Automatische Behebung nach Schließen der Druckerabdeckung.

### 2) Nicht behebbare Fehler

Fehlerbeschreibung	POWER-Lämpchen	ERROR-Lämpchen	Behebungsbedingungen
Papierschnitt-Fehler	Aus	Ein	Dies ist ein nicht behebbarer Fehler. Der Kundendienst muß bezüglich Reparatur kontaktiert werden.
Speicherschalter-Fehler	Blinkt im Abstand von 0,25 s	Blinkt im Abstand von 0,25 s	Dies ist ein nicht behebbarer Fehler. Der Kundendienst muß bezüglich Reparatur kontaktiert werden.
Thermistor-Fehler	Blinkt im Abstand von 0,5 s	Blinkt im Abstand von 0,5 s	Dies ist ein nicht behebbarer Fehler. Der Kundendienst muß bezüglich Reparatur kontaktiert werden.
Stromversorgung-Fehler	Blinkt im Abstand von 1 s	Blinkt im Abstand von 1 s	Dies ist ein nicht behebbarer Fehler. Der Kundendienst muß bezüglich Reparatur kontaktiert werden.

### Hinweis

- 1) Wenn ein nicht behebbarer Fehler auftritt, das Gerät sofort ausschalten.
- 2) Wenn ein Stromversorgung-Fehler auftritt, besteht die Möglichkeit, daß die Netzversorgung nicht richtig ist.  
Bei anderen nicht behebbaren Fehlern muß der Kundendienst bezüglich Reparatur kontaktiert werden.

### 3) Papierschnitt-Fehler

Fehlerbeschreibung	POWER-Lämpchen	ERROR-Lämpchen	Behebungsbedingungen
Papierschnitt-Fehler	Aus	Blinkt im Abstand von 0,125 s	Beheben, wenn des Schneidwerk nach dem Ein- und Ausschalten in Grundstellung zurückkehrt. Wiederherstellung ist auch mit dem Befehl <DEL><ENQ>n möglich, wenn im ESC/POS-Modus.

#### Hinweis

- 1) Wenn das Schneidwerk nicht in Grundstellung zurückkehrt oder nicht die Anfangsbewegung ausführt, ist Behebung nicht möglich.
- 2) Wenn Papierstau vorliegt, ausschalten, den Papierstau beheben, und dann wieder einschalten.
- 3) Handhabung von Papierschnittfehlern, die im Druckerstatus auftreten.  
STAR-Modus: Nicht behebbarer Fehler  
ESC/POS-Modus: Behebbarer Fehler

### 4) Papiererkennung-Fehler

Fehlerbeschreibung	POWER-Lämpchen	ERROR-Lämpchen	Behebungsbedingungen
Papierschnitt-Fehler	Aus	Blinkt im Abstand von 0,5 s	Automatische Behebung durch Einlegen einer neuen Papierrolle und Schließen der Druckerabdeckung.
Papierrollenende fast erreicht	Ein	Blinkt im Abstand von 2 s	Die Anzeigen zeigen, daß das Ende der Papierrolle sich nähert, aber der Drucker druckt weiter.

## 4-3. Selbstdruck

### (1) Testdruck

Das Gerät einschalten, während die FEED-Taste gedrückt gehalten wird. Der Testdruck wird entsprechend der Ver. Nr., den DIP-Schalter-Einstellungen und der Zeichenfolge ausgeführt. Wenn die FEED-Taste beim Ende des Testdrucks gedrückt wird, werden nur die Zeichen wiederholt ausgedruckt.

```
*** TSP600 Ver1.00
```

```
Interface : Parallel
```

```
DIP Switch 1
```

```
Sw 12345678
```

```
On 00000000
```

```
Off
```

```
. : # $ % & ' ( ) * + ,
8 9 : ; < = > ? @ A B C D E F G H
P Q R S T U V W X Y Z [ \ ] ^ _ ` a b c
h i j k l m n o p q r s t u v w x y z { | } ~ *
| _ | - | - | - | - | - | - | - | - | - | - / \
▼ / r t j i k X Ä Ö Ü ß § @ o f ø ½ N Z ¥ ¼ Å ö
```

### (2) Sedezimaler Datenausdruck

Die Druckerabdeckung öffnen, und dann einschalten, während die FEED-Taste gedrückt gehalten wird. Wenn die Abdeckung geschlossen wird, wird "\*\*\*HEX DUMP PRINTING\*\*\*" ausgedruckt, und der Drucker schaltet auf die Betriebsart sedezipimaler Datenausdruck um.

Jedes der vom Computer zum Drucker gesandten Signale wird nun als sedezipimaler Code ausgedruckt.

Diese Funktion erlaubt es, zu prüfen, ob ein von der Sowa zum Drucker gesandter Steuercode korrekt ist oder nicht. Die letzte Zeile wird nicht ausgedruckt, wenn Daten für weniger als eine ganze Zeile vorhanden sind. Wenn die FEED-Taste gedrückt wird, wird aber auch die letzte Zeile ausgedruckt. Zum Ausschalten dieser Betriebsart ist es erforderlich, den Drucker vollständig auszuschalten.

```
*** HEX DUMP PRINTING ***
```

20	21	22	23	24	25	26	27	!	#	\$	%	&			
28	29	2A	2B	2C	2D	2E	2F	()	*	+ ,	-	/			
30	31	32	33	34	35	36	37	0	1	2	3	4	5	6	7
38	39	3A	3B	3C	3D	3E	3F	8	9	:	; <	= >	?		
40	41	42	43	44	45	46	47	@	A	B	C	D	E	F	G
48	49	4A	4B	4C	4D	4E	4F	H	I	J	K	L	M	N	O
50	51	52	53	54	55	56	57	P	Q	R	S	T	U	V	W



## 5. Einlegen der Papierrolle

Immer Rollenpapier verwenden, das zu den technischen Daten des Druckers paßt.

Bei Verwendung einer Papierrolle mit einer Breite von 57,5 mm den optionalen Papierrollenhalter wie auf der folgenden Seite beschrieben, einlegen.

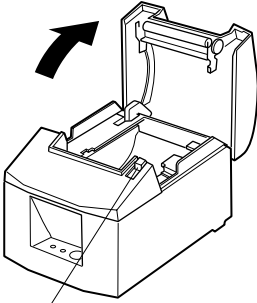

Abdeckung-Öffnen-Hebel

Rollenpapier

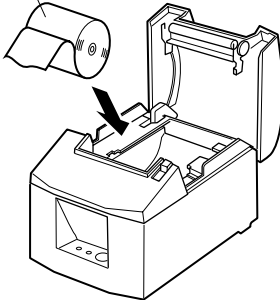

- 1) Den Abdeckung-Öffnen-Hebel drücken, und die Druckerabdeckung öffnen.

- 2) Unter Beachtung der richtigen Einsetzrichtung der Rolle die Papierrolle in die Vertiefung legen und die Vorderkante des Papiers nach vorne ziehen.

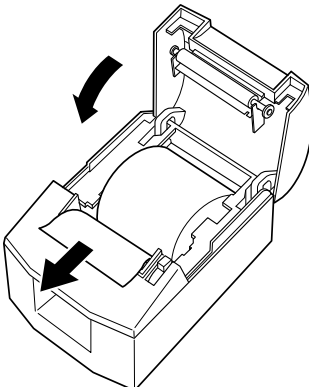
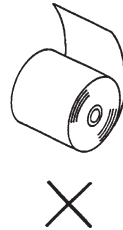
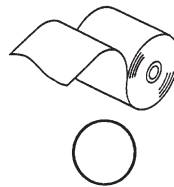

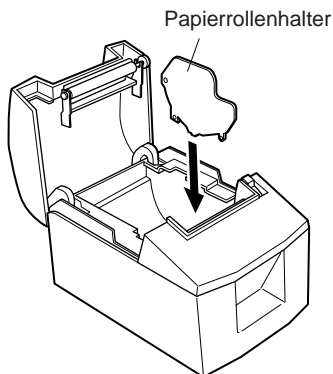

**Hinweis 2:** Bei Verwendung einer Papierrolle mit einer Breite von 57,5 mm den optionalen Papierrollenhalter in die Rille im Drucker setzen.

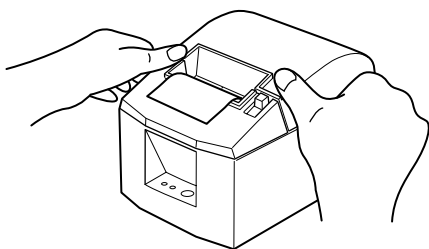

3) Beide Seiten der Druckerabdeckung zum Schließen nach unten drücken.

**Hinweis:** Sicherstellen, daß die Druckerabdeckung fest geschlossen ist.

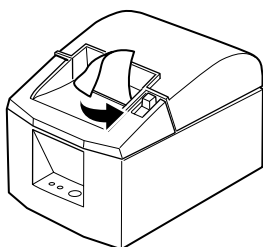

**Abreißkantenmodell**

4) **Abreißkantenmodell:**

Das Papier abreißen, wie in der Abbildung gezeigt.

**Auto-Schneidwerkmodell**

Wenn die Druckerabdeckung nach dem Einschalten geschlossen wird, arbeitet das Schneidwerk automatisch, und das vordere Papierende wird abgeschnitten.

---

## **Wichtig!**

1. *Nicht die Schneidwerkklinge berühren.*
    - *Im Papierauslaßschlitz befindet sich ein Schneidwerk. Niemals die Hände in den Auslaßschlitz stecken, nicht nur während des Druckbetriebs sondern auch wenn der Drucker nicht arbeitet.*
    - *Die Druckerabdeckung kann geöffnet werden, wenn das Papier ausgetauscht wird. Da das Schneidwerk im Inneren der Druckerabdeckung ist, darauf achten, nicht das Gesicht oder die Hände zu nahe an das Schneidwerkmesser zu bringen.*
  2. *Nicht den Abdeckungs-Öffnen-Hebel ziehen und die Druckerabdeckung öffnen, während der Druck abläuft oder wenn die automatische Schneideinheit arbeitet.*
  3. *Nicht den Lösehebel der Abdeckung betätigen, während mit der Hand auf die Druckerabdeckung gedrückt wird.*
  4. *Nicht das Papier bei geschlossener Druckerabdeckung herausziehen.*
  5. *Das Heizelement und der Treiber-Chip des Thermalkopfes werden leicht beschädigt. Diese Teile nicht mit Metallgegenständen, Sandpapier usw. berühren.*
  6. *Während des Druckens und kurz nach dem Drucken kann der Bereich um den Thermalkopf sehr heiß werden. Nicht das Heizelement mit der Hand berühren.*
  7. *Die Druckqualität kann nachlassen, wenn das Thermalkopf-Heizelement durch Berührung mit der Hand verschmutzt wird. Nicht das Thermalkopf-Heizelement berühren.*
  8. *Es besteht die Gefahr von Schäden am Treiber-Chip durch statische Elektrizität. Niemals den Chip direkt berühren.*
  9. *Die Druckqualität und die Lebensdauer des Thermalkopfes kann nicht garantiert werden, wenn anderes als Papier der vorgeschriebenen Sorte verwendet wird. Insbesondere Papier mit [Na<sup>+</sup>, K<sup>+</sup>, Cl<sup>-</sup>] kann die Lebensdauer des Thermalkopfes drastisch verkürzen. Bitte vorsichtig arbeiten.*
  10. *Nicht den Drucker betreiben, wenn Feuchtigkeit durch Beschlag usw. an der Vorderseite des Druckkopfes vorhanden ist.*
-

## 6. Einstellung des Endanäherungs-Sensors

Den Endanäherungs-Sensor auf folgende Weise justieren, damit er der Größe der verwendeten Papierrolle entspricht.

- ① Die Druckerabdeckung öffnen.
- ② Den Durchmesser der verwendeten Papierrolle ermitteln, und in der untenstehenden Tabelle die entsprechende Einstellung aufsuchen.
- ③ Die Spitze eines Kugelschreibers o.ä. Gegenstands in das Loch des Einstellers stecken, und dann eindringen und den Einsteller auf die gewünschte Einstellung schieben.

Beim Ändern der Einstellung sicherstellen, daß die Position des Lochs mit der durch Pfeil markierten Ausrichtmarkierung ausgerichtet ist.

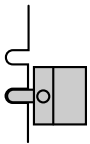
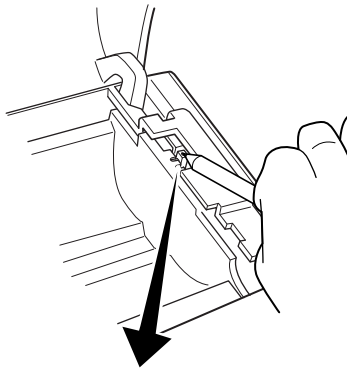

(Niveau 1)

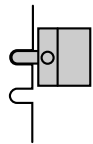

(Niveau 2)

## Einstellwerte entsprechend des verwendeten Papiers

Papierdicke ( $\mu\text{m}$ )	Bei Verwendung einer Papierrolle mit einem Kern mit Innendurchmesser (A): $\phi 12$ und Außendurchmesser (B): $\phi 18$			
	Erkannter Durchmesser (C) (Etwa mm)		Rest papier (Etwa m)	
	Niveau 1	Niveau 2	Niveau 1	Niveau 2
65	$\phi 23$	$\phi 29$	2,7	7,3
85	$\phi 21$		1,2	5,5

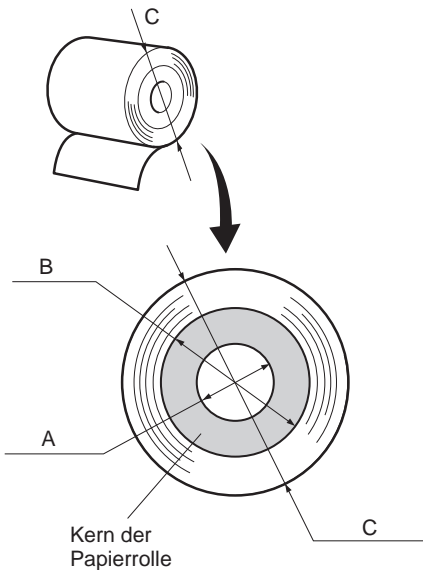

### Hinweis

- 1) Das Standardmodell ist werkseitig auf Niveau 1 gestellt.
- 2) Die Abmessung C und die restliche Papierlänge sind berechnete Werte. Es können leichte Abweichungen zum tatsächlichen Wert auftreten.
- 3) Da Lockerung im Papier auftritt und zu einem Zunehmen der Diskrepanz zwischen den C-Abmessungen und der restlichen Papierlänge führt, wenn das verwendete Papier eine Druckerdicke von  $85 \mu\text{m}$  hat, wird empfohlen, Niveau 2 zu verwenden.

## 7. Verhindern und Beheben von Papierstau

### 7-1. Verhindern von Papierstau

Das Papier soll beim Ausgeben und vor dem Schneiden nicht berührt werden. Wenn das Papier beim Ausgeben gedrückt oder gezogen wird, kann ein Papierstau, ein Abschneidfehler oder ein Zeilenvorschubfehler verursacht werden.

### 7-2. Beheben von Papierstau

Wenn ein Papierstau auftritt, beheben Sie ihn wie folgt.

(1) Stellen Sie den Netzschalter auf Aus, um den Drucker auszuschalten.

(2) Ziehen Sie den Hebel nach vorne, um die Druckerabdeckung zu öffnen.

Wenn die Druckerabdeckung sich bei Modellen mit automatischer Abschneideinheit nicht öffnet, bedeutet dies, daß die automatische Abschneideinheit nicht in Grundstellung ist. In diesem Fall die automatische Abschneideinheit entsprechend den in Abschnitt 7-3 gegebenen Anweisungen auf Grundstellung zurückstellen. Dann die Druckerabdeckung öffnen, nachdem der Papierstau behoben ist.

(3) Entfernen Sie das gestaute Papier.

**Hinweis:** Achten Sie darauf, den Drucker beim Entfernen des gestauten Papiers nicht zu beschädigen. Insbesondere der Thermaldruckkopf läßt sich leicht beschädigen; achten Sie darauf, ihn nicht zu berühren.

(4) Stellen Sie sicher, daß das Papier gerade ausgerichtet ist, und schließen Sie die Druckerabdeckung vorsichtig.

**Hinweis 1:** Stellen Sie sicher, daß das Papier gerade ausgerichtet ist. Wenn die Druckerabdeckung bei schief liegendem Papier geschlossen wird, kann ein Papierstau auftreten.

**Hinweis 2:** Sperren Sie die Druckerabdeckung durch Drücken auf die Seiten. Nicht zum Schließen auf die Mitte drücken. Dabei kann es sein, daß die Abdeckung nicht richtig schließt.

(5) Stellen Sie den Netzschalter in Ein-Stellung, um den Drucker einzuschalten. Stellen Sie sicher, daß die ERROR-LED nicht leuchtet.

**Hinweis:** Während die ERROR-LED leuchtet, akzeptiert der Drucker keine Befehle wie Druckbefehl; stellen Sie deshalb sicher, daß die Abdeckung richtig geschlossen ist.

### 7-3. Freigeben eines gesperrten Schneidmessers Nur Auto-Schneidwerkmodell

Wenn das automatische Schneidmesser sperrt oder das Papier nicht schneidet, wie folgt verfahren.

---

#### **Achtung:**

*Da Arbeiten am Schneidmesser gefährlich sein können, immer zuerst den Drucker ausschalten.*

---

- (1) Den Netzschalter auf Aus (OFF) stellen, um den Drucker auszuschalten.
- (2) Die Frontabdeckung abschieben, um das Schneidmesser freizulegen.
- (3) Gestautes Papier entfernen.

**Hinweis:** Darauf achten, nicht den Drucker nicht beim Entfernen von gestautem Papier zu beschädigen.

Da der Thermalkopf besonders empfindlich ist, darauf achten, ihn nicht zu berühren.

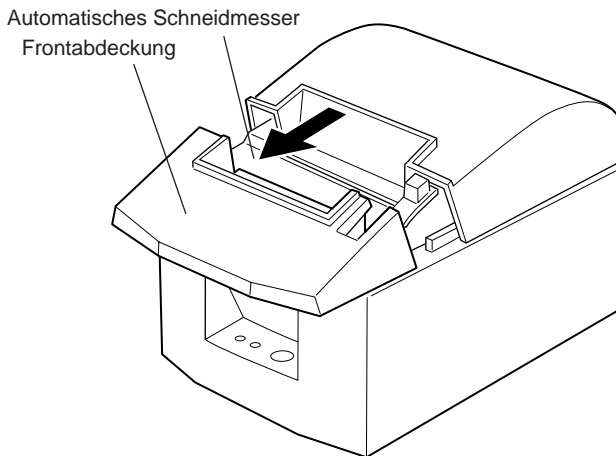

- (4) Wenn die bewegliche Klinge des Schneidmessers hervorsteht, mit einem Kreuzschlitzschraubenzieher die Kreuzschlitzschraube drehen, und die bewegliche Klinge in Grundstellung zurückstellen. Wenn das Prüffenster vollständig weiß ist, ist die bewegliche Klinge in Grundstellung.

**Hinweis 1:** Nicht starken Druck auf die bewegliche Klinge ausüben.

**Hinweis 2:** Wenn die bewegliche Klinge zu sehr hervorsteht, kann die Druckerabdeckung nicht geöffnet werden. Wenn versucht wird, die Abdeckung zu öffnen, kann das Schneidmesser beschädigt werden.

- (5) Die Druckerabdeckung öffnen, gestautes Papier entfernen, und dann die Papierrolle wieder einsetzen.
- (6) Die Frontabdeckung wieder einsetzen, und den Netzschalter auch Ein (ON) stellen.

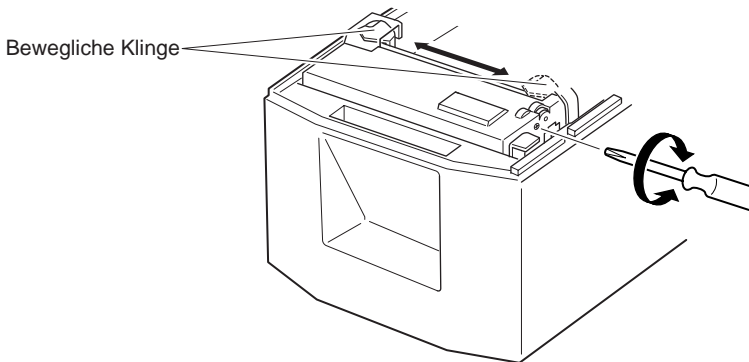



## 8. Regelmäßige Reinigung

Die Druckzeichen können durch Ansammlung von Papierstaub und anderem Schmutz unscharf werden. Um das zu verhindern, muß im Papierhalter und in der Papiertransportstufe angesammelter Staub von Zeit zu Zeit entfernt werden. Diese Reinigung sollte einmal alle sechs Monate oder einmal nach jeder Million Zeilen ausgeführt werden.

### 8-1. Reinigen des Thermalkopfes

Zum Entfernen von schwärzlichem Staub auf der Oberfläche des Thermalkopfes diesen mit Isopropylalkohol (IPA) abwischen.

**Hinweis:** Der Thermalkopf läßt sich leicht beschädigen. Zum Abwischen immer einen sehr weichen Lappen verwenden und sicherstellen, daß er nicht zerkratzt wird.

### 8-2. Reinigen des Papierhalters

Verwenden Sie einen weichen Lappen zur Entfernung von Papierstaub vom Papierhalter und aus der Papiertransportstufe.



# INDICE

<b>1. Identificazione delle parti e nomenclatura .....</b>	<b>73</b>
<b>2. Parti soggette a consumo e trasformatore CA .....</b>	<b>76</b>
<b>3. Cavi di collegamento e trasformatore CA .....</b>	<b>78</b>
3-1. Cavo interfaccia .....	78
3-2. Collegamento ad un'unità periferica .....	80
3-3. Collegamento del trasformatore CA opzionale .....	81
3-4. Accensione .....	82
<b>4. Pannello di controllo e altre funzioni .....</b>	<b>83</b>
4-1. Pannello di controllo .....	83
4-2. Errori .....	83
4-3. Stampa automatica .....	85
<b>5. Inserimento del rotolo di carta .....</b>	<b>86</b>
<b>6. Regolazione del sensore di esaurimento prossimo .....</b>	<b>89</b>
<b>7. Prevenzione e soluzione degli inceppamenti della carta .....</b>	<b>91</b>
7-1. Prevenzione degli inceppamenti della carta .....	91
7-2. Eliminazione degli inceppamenti della carta .....	91
7-3. Rilascio della taglierina bloccata (solo modello con taglierina automatica) .....	92
<b>8. Pulizia periodica .....</b>	<b>94</b>
8-1. Pulizia della testina termica .....	94
8-2. Pulizia del comparto carta .....	94
<b>APPENDICE .....</b>	<b>95</b>

*L'Appendice appare solo nella sezione in inglese di questo manuale.*

Visitare il seguente indirizzo URL

[http://www.star-micronics.co.jp/service/frame\\_sp\\_spr\\_e.htm](http://www.star-micronics.co.jp/service/frame_sp_spr_e.htm)

per accedere alla versione più recente del manuale.

# 1. Identificazione delle parti e nomenclatura

## Modello con taglierina automatica

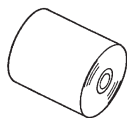
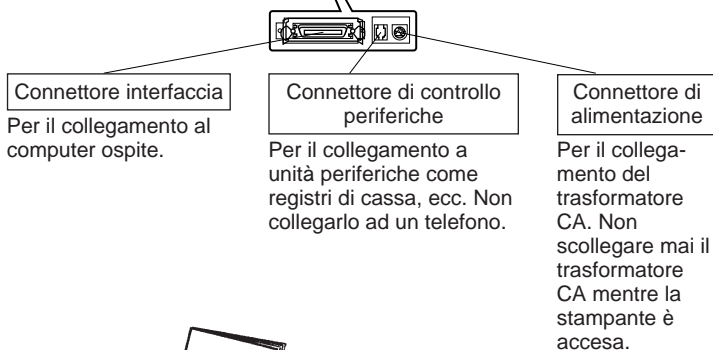
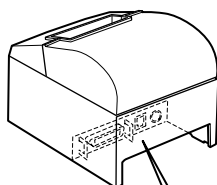
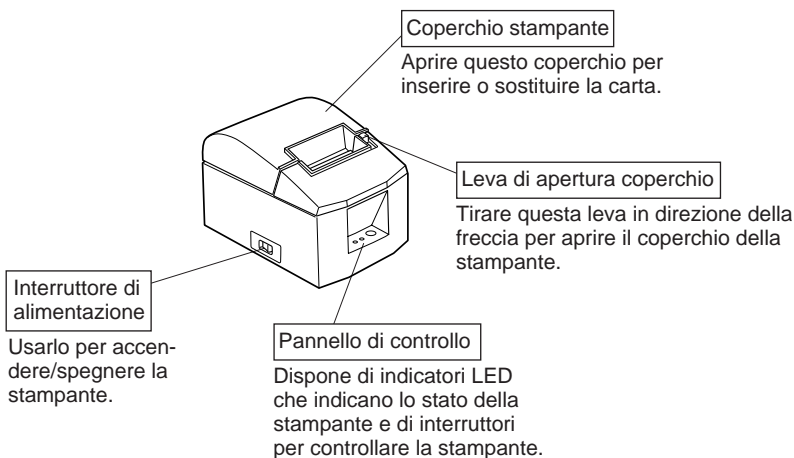

Carta in rotolo



Manuale dell'utilizzatore



Anello di ferrite

(Solo modello a interfaccia parallelo)



Fascetta di fissaggio

(Solo modello a interfaccia parallelo)

## Modello con barra di strappo

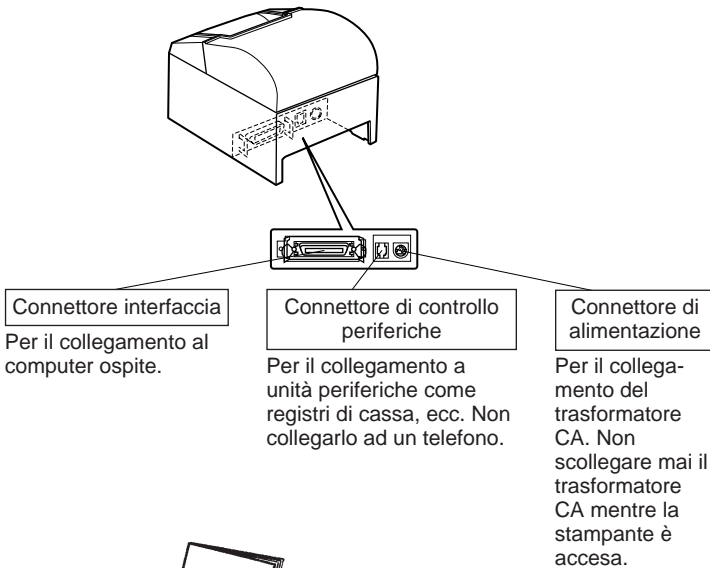
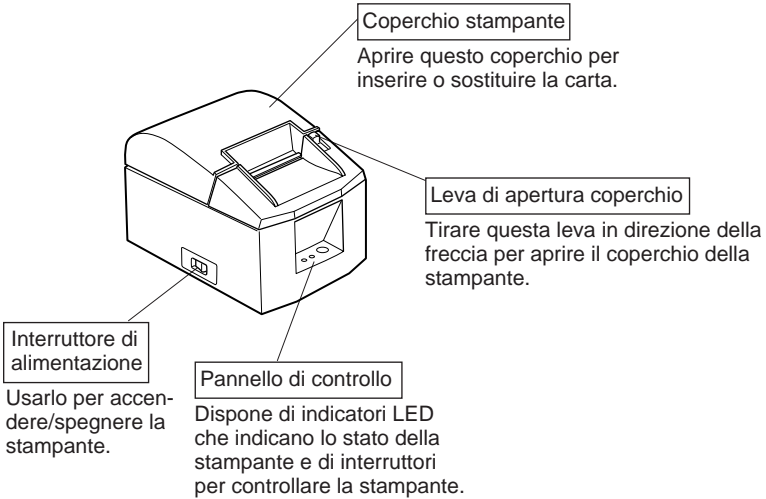

Carta in rotolo



Manuale dell'utilizzatore



Anello di ferrite  
(Solo modello a interfaccia parallelo)



Fascetta di fissaggio  
(Solo modello a interfaccia parallelo)

## Scelta di un luogo per la stampante

Prima di disimballare la stampante, decidere dove si desidera installarla. Tenere presenti i seguenti punti.

- ✓ Scegliere una superficie stabile e in piano, dove la stampante non sia esposta a vibrazioni.
- ✓ La presa di corrente che si intende usare per la stampante deve essere vicina e libera da ostacoli.
- ✓ La stampante deve essere abbastanza vicina al computer da permettere il collegamento tra i due.
- ✓ Assicurarsi che la stampante non sia esposta alla luce solare diretta.
- ✓ Assicurarsi che la stampante sia lontana da caloriferi e altre fonti di calore elevato.
- ✓ Assicurarsi che l'area circostante sia pulita, asciutta e priva di polvere.
- ✓ Assicurarsi che la stampante sia collegata ad una presa di corrente affidabile. Non deve essere la stessa presa di corrente di copiatrici, frigoriferi e altre apparecchiature che causano picchi di corrente.
- ✓ Assicurarsi che la stanza dove si usa la stampante non sia troppo umida.

## 2. Parti soggette a consumo e trasformatore CA

Quando le parti soggette a consumo si sono esaurite, usare quelle specificate nella seguente tabella. Assicurarsi di usare il trasformatore CA specificato nella tabella. L'uso di parti soggette a consumo o di un trasformatore CA diversi da quanto specificato nella tabella può causare danni alla stampante, incendi o scosse elettriche.

### (1) Carta in rotolo specifiche

Carta termica

Spessore: 65~85  $\mu\text{m}$

Larghezza: 79,5 $\pm$ 0,5 mm (57,5 $\pm$ 0,5 mm quando si usa il supporto per rotolo di carta opzionale)

Diametro esterno rullo:  $\varnothing$ 90 mm or less

Larghezza carta del rullo di raccolta: 80 $^{+0.5}_{-1}$  mm (58 $^{+0.5}_{-1}$  mm quando si usa il supporto per rotolo di carta opzionale)

Diametro interno/esterno nucleo

Spessore carta	Nucleo: esterno	Nucleo: interno
65~85 $\mu\text{m}$	$\varnothing$ 18 $\pm$ 1 mm	$\varnothing$ 12 $\pm$ 1 mm

Superficie stampata: Bordo esterno del rotolo

Maneggio dell'estremità finale: Non usare colla o adesivi per fissare la carta del rotolo o il suo nucleo.

Non piegare l'estremità finale della carta.

### (2) Carta consigliata

Mitsubishi Paper Mills Limited

P220AG (carta di tipo normale), 65  $\mu\text{m}$  (spessore)

HP220A (carta a stabilità immagine alta), 65  $\mu\text{m}$  (spessore)

HP220AB-1 (carta a stabilità immagine alta), 75  $\mu\text{m}$  (spessore)

P220AB (carta di tipo normale, biglietti scheda), 85  $\mu\text{m}$  (spessore)

Oji Paper Co., Ltd.

PD150R (carta di tipo normale), 75  $\mu\text{m}$  (spessore)

PD160R (carta a stabilità immagine alta), 65/75  $\mu\text{m}$  (spessore)

Nippon Paper Industries

TF50KS-E2C (carta di tipo normale), 65  $\mu\text{m}$  (spessore)

A seconda del tipo e dello spessore della carta, può essere necessario cambiare le impostazioni per la densità di stampa. Per cambiare le impostazioni di densità, usare il comando di impostazione densità di stampa <ESC><RS>'d'n. Fare riferimento al manuale del programmatore separato per dettagli.

(3) Trasformatore CA (opzionale)

Nome modello: PS60-24 A

Ingresso: Da 100 a 240 V CA, 50/60 Hz

Uscita:  $24 \pm 5\%$  CC, 2,0 A (5,0 A carico 10 sec. mass.)

---

***Importante!***

*Accedere alla seguente URL per informazioni sulla carta consigliata.*

*<http://www.star-micronics.co.jp/>*

---



## 3. Cavi di collegamento e trasformatore CA

### 3-1. Cavo interfaccia

#### 3-1-1. Installazione dell'anello di ferrite (solo modello a interfaccia parallelo)

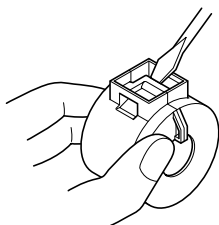

Anello di ferrite

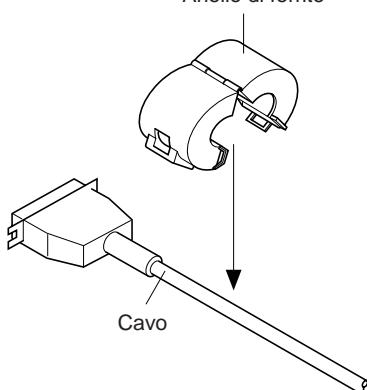

- (1) Solo per il modello a interfaccia parallelo, fissare l'anello di ferrite al cavo come mostrato nell'illustrazione qui sotto.

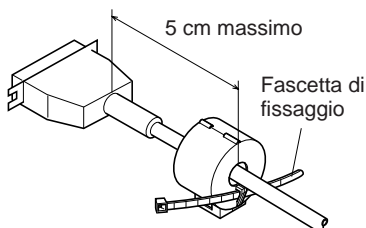

- (2) Far passare la fascetta di fissaggio attraverso l'anello di ferrite.

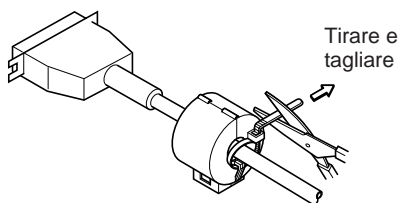

- (3) Avvolgere la fascetta intorno al cavo e fissarla. Usare delle forbici per tagliare la parte in eccesso.

## 3-1-2. Collegamento del cavo interfaccia

**Nota:** Prima di collegare/scollegare il cavo interfaccia, assicurarsi che la stampante e tutti i dispositivi collegati alla stampante siano spenti.

**Inoltre assicurarsi che la spina del cavo di alimentazione sia scollegata dalla presa di corrente.**

- (1) Collegare il cavo interfaccia al connettore sul pannello posteriore della stampante.
- (2) Nel caso di un'interfaccia seriale, serrare le viti del connettore. Nel caso di un'interfaccia parallelo, fissare i morsetti del connettore.

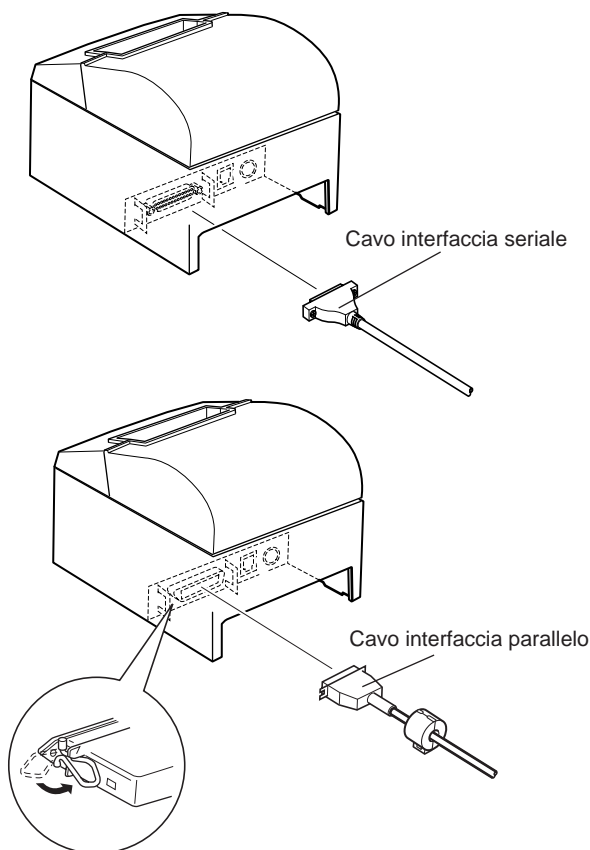

## 3-2. Collegamento ad un'unità periferica

Si può collegare un'unità periferica alla stampante usando una spina modulare. Di seguito descriviamo come installare l'anello di ferrite ed eseguire il collegamento. Vedere "Modulare necessario" a pagina 108 per dettagli sul tipo di spina modulare necessario. Notare che la stampante non è dotata di spina o filo modulare, che devono essere acquistati in base alle esigenze di impiego.

---

### **Importante!**

Assicurarsi che la stampante sia spenta e scollegata dalla presa di corrente e che il computer sia spento prima di eseguire il collegamento.

---

(1) Collegare il cavo di controllo periferiche al connettore sul pannello posteriore della stampante.

---

### **Importante!**

*Non collegare una linea telefonica al connettore di controllo esterno. Altrimenti si potrebbero avere danni alla stampante.*

*Inoltre, per ragioni di sicurezza, non collegare fili al connettore di controllo esterno, perché se ci sono cambiamenti potrebbero condurre una tensione eccessiva.*

---

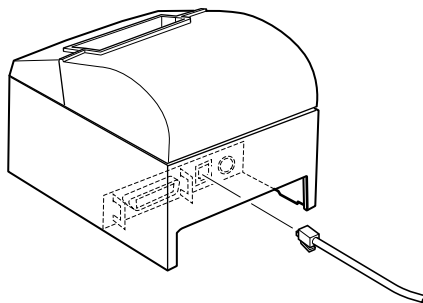

### 3-3. Collegamento del trasformatore CA opzionale

**Nota:** Prima di collegare/scollegare il trasformatore CA, assicurarsi che la stampante e tutti i dispositivi collegati alla stampante siano spenti. Inoltre assicurarsi che la spina del cavo di alimentazione sia scollegata dalla presa di corrente.

(1) Collegare il trasformatore CA al cavo di alimentazione.

**Nota:** Usare solo il trasformatore CA e cavo di alimentazione standard.

(2) Collegare il trasformatore CA al connettore sulla stampante.

(3) Collegare la spina del cavo di alimentazione ad una presa di corrente.

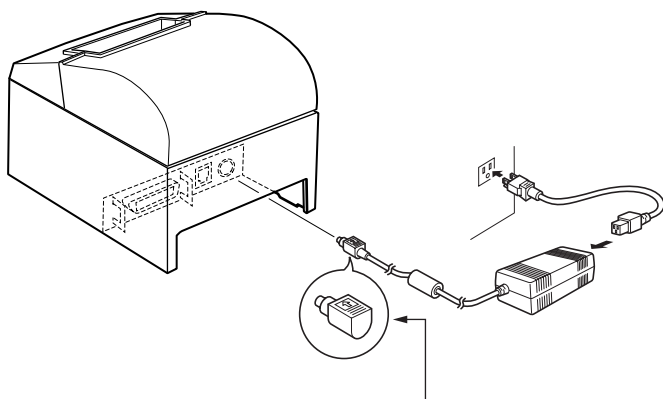

---

#### ***Importante!***

Quando si scollega il cavo, afferrare il connettore del cavo per tirare. Sbloccando il fermo è facile scollegare il connettore.

Se si tira il cavo con forza eccessiva si possono causare danni al connettore.

---

### 3-4. Accensione

Assicurarsi che il trasformatore CA sia stato collegato come indicato nella sezione 3-3.

(1) Regolare su ON l'interruttore di alimentazione situato sul davanti della stampante.

La spia POWER sul pannello di controllo si illumina.

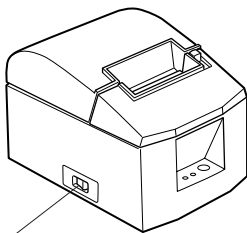

Interruttore di alimentazione

---

#### ***Importante!***

*Consigliamo di scollegare la stampante dalla presa di corrente quando si prevede di non usarla per un lungo periodo. Per questo motivo, la stampante deve essere collocata in modo che la presa di corrente sia vicina e facilmente accessibile.*

---

## 4. Pannello di controllo e altre funzioni

### 4-1. Pannello di controllo

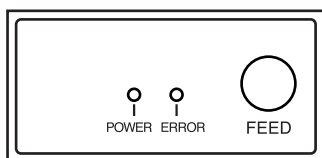

- ① Spia POWER (LED verde)  
Si illumina quando l'unità è accesa.
- ② Spia ERROR (LED rosso)  
Indica vari errori in combinazione con la spia POWER.
- ③ Tasto FEED  
Premere il tasto FEED per far avanzare la carta su rotolo.

### 4-2. Errori

#### 1) Errori con recupero automatico

Descrizione dell'errore	Spia POWER	Spia ERROR	Condizioni di recupero
Individuazione temperatura testina elevata	Lampeggia a intervalli di 0,5 secondi	Spenta	Recupero automatico dopo che la testina di stampa si è raffreddata.
Errore di coperchio aperto	Accesa	Accesa	Recupero automatico con la chiusura del coperchio stampante.

#### 2) Errori senza recupero

Descrizione dell'errore	Spia POWER	Spia ERROR	Condizioni di recupero
Errore RAM	Spenta	Accesa	Questo errore è senza recupero. Consultare il rivenditore per riparazioni.
Errore interruttore memoria	Lampeggia a intervalli di 0,25 secondi	Lampeggia a intervalli di 0,25 secondi	Questo errore è senza recupero. Consultare il rivenditore per riparazioni.
Errore termistore	Lampeggia a intervalli di 0,5 secondi	Lampeggia a intervalli di 0,5 secondi	Questo errore è senza recupero. Consultare il rivenditore per riparazioni.
Errore alimentazione	Lampeggia a intervalli di 1 secondo	Lampeggia a intervalli di 1 secondo	Questo errore è senza recupero. Consultare il rivenditore per riparazioni.

#### Nota

- 1) Se si verifica un errore senza recupero, spegnere immediatamente l'unità.
- 2) Quando si verifica un errore alimentazione, esiste la possibilità che l'unità di alimentazione sia guasta.  
Per altri errori senza recupero, consultare il rivenditore per riparazioni.

### 3) Errore di taglio carta

Descrizione dell'errore	Spia POWER	Spia ERROR	Condizioni di recupero
Errore di taglio carta	Accesa	Lampeggia a intervalli di 0,125 secondi	Recupero se la taglierina ritorna alla posizione di riposo dopo che si è spenta e riaccesa l'unità. Il ripristino è possibile anche con il comando <DEL><ENQ>n nel modo ESC/POS.

#### Nota

- 1) Se la taglierina non ritorna alla posizione di riposo, o non esegue il movimento iniziale, il recupero non è possibile.
- 2) Se la carta è inceppata spegnere l'unità, eliminare l'inceppamento e quindi riaccendere.
- 3) Gestione degli errori di taglio carta che si verificano nello stato stampante.  
Modo STAR: Errore non ripristinabile  
Modo ESC/POS: Errore ripristinabile

### 4) Errori di rilevamento carta

Descrizione dell'errore	Spia POWER	Spia ERROR	Condizioni di recupero
Errore di carta esaurita	Accesa	Lampeggia a intervalli di 0,5 secondi	Recupero automatico quando si inserisce un nuovo rullo di carta e si chiude il coperchio stampante.
Carta quasi esaurita	Accesa	Lampeggia a intervalli di 2 secondi	Le spie indicano che la carta è quasi finita, ma la stampante continua a stampare.

## 4-3. Stampa automatica

### (1) Stampa di prova

Accendere l'unità tenendo premuto il tasto FEED.

La stampa di prova viene eseguita nell'ordine di numero di versione, impostazioni degli interruttori DIP e ordine dei caratteri. Se si preme il tasto FEED alla fine della stampa di prova, sono stampati ripetutamente solo i caratteri.

\*\*\* TSP600 Ver1.00

Interface : Parallel

DIP Switch 1

Sw 12345678

On \*\*\*\*\*

Off

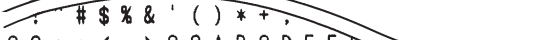

. # \$ % & ' ( ) \* + ,  
 8 9 : ; < = > ? @ A B C D E F G  
 P Q R S T U V W X Y Z [ \ ] ^ \_ ` a b c  
 h i j k l m n o p q r s t u v w x y z { | } ~ \*  
 ! " # \$ % & ' ( ) \* + , - . / : ; < = > ?  
 @ A B C D E F G H I J K L M N O P Q R S T U V W  
 X Y Z [ \ ] ^ \_ ` a b c d e f g h i j k l m n o  
 p q r s t u v w x y z { | } ~ \* + , - . / : ; < = > ?

ITALIANO

### (2) Modo di scaricamento esadecimale

Aprire il coperchio stampante, quindi accendere l'unità tenendo premuto il tasto FEED. Quando si chiude il coperchio viene stampato "\*\*\* HEX DUMP PRINTING\*\*\*" e la stampante passa al modo di scaricamento esadecimale. Ciascuno dei segnali inviati dal computer alla stampante viene stampante come codice esadecimale.

Questa funzione permette di controllare se un codice di controllo inviato alla stampante dal programma usato è corretto oppure no. L'ultima riga non viene stampata se i suoi dati con costituiscono una riga completa. Tuttavia, se si preme il tasto FEED, viene stampata l'ultima riga. Per disattivare questo modo è necessario spegnere completamente la stampante.

\*\*\* HEX DUMP PRINTING \*\*\*

20	21	22	23	24	25	26	27	!"#\$%&'
28	29	2A	2B	2C	2D	2E	2F	()*+,-./
30	31	32	33	34	35	36	37	01234567
38	39	3A	3B	3C	3D	3E	3F	89:;<=>?
40	41	42	43	44	45	46	47	@ABCDEFGH
48	49	4A	4B	4C	4D	4E	4F	IJKLMNOPQ
50	51	52	53	54	55	56	57	RSTUVW



## 5. Inserimento del rotolo di carta

Assicurarsi di usare carta su rotolo che corrisponde alle specifiche della stampante.

Quando si usa un rotolo di carta della larghezza di 57,5 mm, installare il supporto per rotolo di carta opzionale come descritto nella pagina seguente.

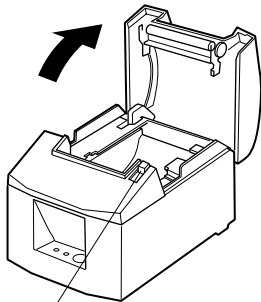

Leva di apertura coperchio

Carta su rotolo

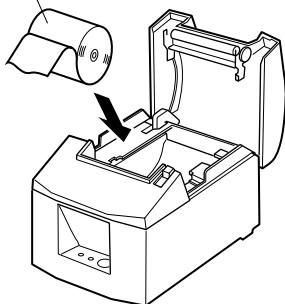

- 1) Spingere la leva di apertura coperchio e aprire il coperchio stampante.

- 2) Osservando l'orientamento del rotolo, inserire il rotolo di carta nel vano e tirare il bordo iniziale della carta verso di sé.

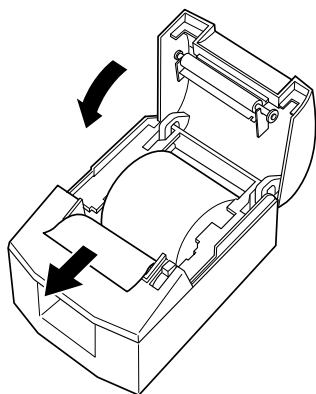
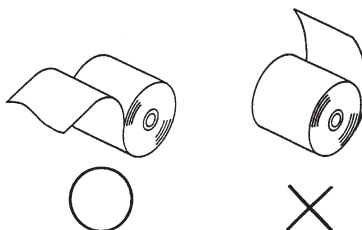

Supporto del rotolo di carta

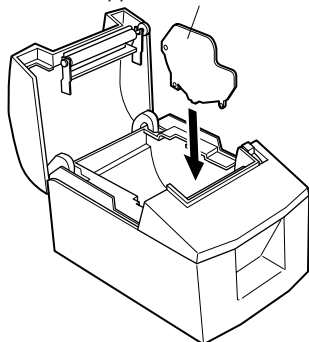

**Nota 2:** Quando si usa un rotolo di carta della larghezza di 57,5 mm, installare il supporto per rotolo di carta opzionale nella scanalatura sulla stampante.

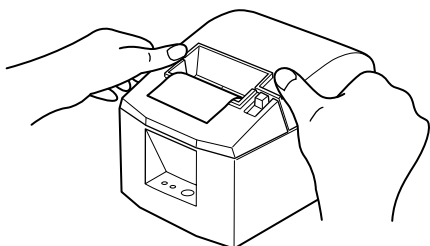

3) Premere su entrambi i lati del coperchio stampante per chiudere.

**Nota:** Assicurarsi che il coperchio stampante sia saldamente chiuso.

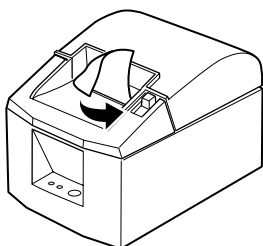

**Modello con barra di strappo**

4) **Modello con barra di strappo:**

Strappare la carta come illustrato.

**Modello con taglierina automatica:**

Se il coperchio stampante è chiuso dopo l'accensione, la taglierina agisce automaticamente e il bordo anteriore della carta viene tagliato.

---

## **Importante!**

1. *Non toccare la lama della taglierina.*
    - *All'interno della fessura di uscita carta si trova una taglierina. Non mettere mai la mano nella fessura di uscita della carta durante la stampa e non mettere mai la mano nella fessura anche quando la stampa non è in corso.*
    - *Il coperchio della stampante può essere aperto quando si sostituisce la carta. Tuttavia, poiché la lama della taglierina si trova all'interno del coperchio stampante, fare attenzione a non avvicinare eccessivamente le mani o il volto alla lama della taglierina.*
  2. *Non tirare la leva di apertura del coperchio per aprire il coperchio stampante mentre la stampa è in corso o quando la taglierina automatica è in funzione.*
  3. *Non azionare la leva di apertura del coperchio mentre si preme sul coperchio stampante con la mano.*
  4. *Non estrarre la carta con il coperchio stampante chiuso.*
  5. *L'elemento riscaldante e il circuito integrato pilota sulla testina termica si danneggiano facilmente. Non toccarli con oggetti metallici, carta vetrata, ecc.*
  6. *Durante la stampa e subito dopo, l'area circostante la testina termica è molto calda. Non toccare perché si potrebbero subire ustioni.*
  7. *Se l'elemento riscaldante della testina termica si è sporcato perché è stato toccato con le mani, la qualità di stampa può risentirne. Non toccare l'elemento riscaldante della testina termica.*
  8. *Esiste il rischio di danni al circuito integrato pilota della testina di termica nel caso di elettricità statica. Non toccare mai direttamente il circuito integrato.*
  9. *La qualità di stampa e la vita utile della testina termica non possono essere garantite se si usa qualsiasi carta diversa da quella consigliata. In particolare, carta contenente [Na<sup>+</sup>, K<sup>+</sup>, Cl<sup>-</sup>] può ridurre drasticamente la vita utile della testina termica. Si prega di fare attenzione.*
  10. *Non usare la stampante se è presente umidità sulla parte anteriore della testina, a causa di condensa, ecc.*
-

## 6. Regolazione del sensore di esaurimento prossimo

Usare il seguente procedimento per regolare il sensore di esaurimento prossimo in modo che sia compatibile con le dimensioni del rotolo di carta usato.

- ① Aprire il coperchio stampante.
- ② Misurare il diametro del rotolo di carta usato e trovare l'impostazione necessaria nella tabella sotto.
- ③ Inserire la punta di una penna a sfera o un oggetto simile nel foro sul regolatore e quindi premere e spostare il regolatore sull'impostazione desiderata. Quando si cambia l'impostazione, assicurarsi che la posizione del foro sia allineata con il segno di allineamento indicato dalla freccia.

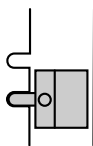
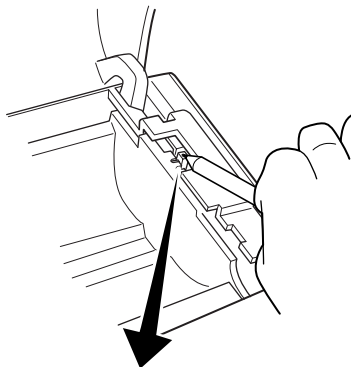

(Livello 1)

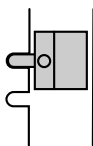

(Livello 2)

## Valore di regolazione secondo la carta usata

Spessore carta ( $\mu\text{m}$ )	Quando si usa un rotolo di carta con nucleo di diametro interno (A): $\phi 12$ , diametro esterno (B): $\phi 18$			
	Diametro individuato (C) (mm circa)		Lunghezza carta rimanente (m circa)	
	Livello 1	Livello 2	Livello 1	Livello 2
65	$\phi 23$	$\phi 29$	2,7	7,5
85	$\phi 21$		1,2	5,5

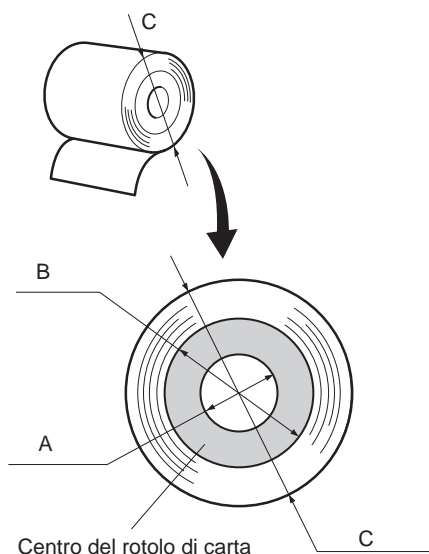

### Nota

- 1) Il modello standard è impostato sul livello 1 prima di uscire dalla fabbrica.
- 2) La dimensione C e la lunghezza di carta rimanente sono valori calcolati. Si possono avere leggere variazioni nell'uso effettivo.
- 3) Poiché si verificano allentamenti della carta, che causano un aumentare delle discrepanze tra le dimensioni C e la lunghezza carta rimanente, quando si usa carta con uno spessore stampante di  $85 \mu\text{m}$ , si consiglia di usare il Livello 2.

## 7. Prevenzione e soluzione degli inceppamenti della carta

### 7-1. Prevenzione degli inceppamenti della carta

La carta non deve essere toccata durante l'espulsione e prima che sia tagliata. Se si preme o si tira la carta durante l'espulsione si può verificare un inceppamento della carta, un mancato taglio della carta o un avanzamento di riga mancato.

### 7-2. Eliminazione degli inceppamenti della carta

Se si verifica un inceppamento della carta, eliminarlo come descritto di seguito.

(1) Regolare l'interruttore di alimentazione su OFF per spegnere la stampante.

(2) Tirare la leva verso di sé per aprire il coperchio stampante.

Se il coperchio stampante non si apre sui modelli dotati di taglierina automatica, vuol dire che la taglierina automatica non è nella posizione di riposo. In questo caso, riportare la taglierina automatica alla posizione di riposo seguendo le istruzioni fornite nella sezione 7-3. Poi aprire il coperchio stampante dopo aver eliminato l'inceppamento carta.

(3) Rimuovere la carta inceppata.

**Nota:** Fare attenzione a non danneggiare la stampante quando si rimuove la carta inceppata. Poiché la testina di stampa in particolare viene danneggiata facilmente, fare attenzione a non toccarla.

(4) Collocare diritto il rotolo di carta e chiudere delicatamente il coperchio stampante.

**Nota 1:** Assicurarsi che la carta sia ben diritta. Se si chiude il coperchio stampante con la carta storta, si può verificare un inceppamento della carta.

**Nota 2:** Bloccare il coperchio stampante premendo in basso sui lati. Non tentare di chiuderlo premendo sul centro. Il coperchio potrebbe non bloccarsi correttamente.

(5) Regolare su ON l'interruttore di alimentazione per accendere la stampante. Assicurarsi che la spia ERROR non sia illuminata.

**Nota:** Mentre la spia ERROR è illuminata, la stampante non accetta alcun comando come il comando di stampa, per cui assicurarsi che il coperchio della stampante sia bloccato correttamente.

### 7-3. Rilascio della taglierina bloccata (solo modello con taglierina automatica)

Se la taglierina automatica si blocca o non taglia la carta, procedere come segue.

---

#### **Cautela:**

*Poiché lavorare con la taglierina può essere pericoloso, non dimenticare di spegnere prima la stampante.*

---

- (1) Regolare l'interruttore di alimentazione su OFF per spegnere la stampante.
- (2) Spostare il coperchio anteriore per scoprire la taglierina automatica.
- (3) Rimuovere eventuale carta inceppata.

**Nota:** Fare attenzione a non danneggiare la stampante durante la rimozione della carta inceppata.

Poiché la testina di stampa termica è particolarmente sensibile, fare attenzione a non toccarla.

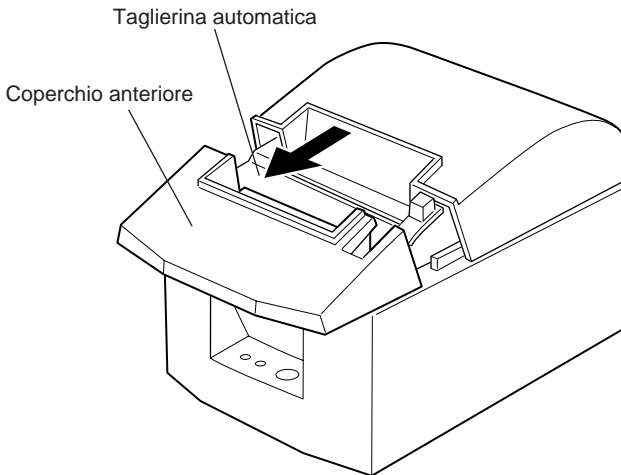

(4) Se la lama mobile della taglierina sporge, usare un cacciavite Philips per girare la vite a testa Philips e riportare la lama mobile alla sua posizione di partenza. Quando la finestrella di controllo appare completamente bianca, la lama mobile è nella sua posizione di partenza.

**Nota 1:** Non applicare estrema pressione alla lama mobile.

**Nota 2:** Se la lama mobile sporge eccessivamente, non è possibile aprire il coperchio stampante. Se si tenta di aprire il coperchio stampante si può danneggiare la taglierina.

(5) Aprire il coperchio stampante, rimuovere eventuale carta inceppata e quindi reinstallare il rotolo di carta.

(6) Installare il coperchio anteriore e quindi regolare l'interruttore di alimentazione su ON.

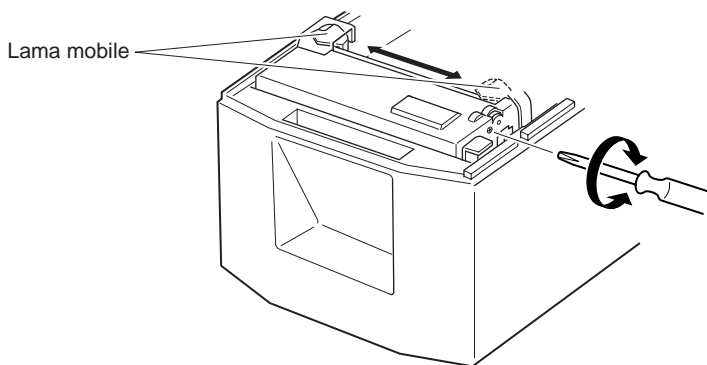



## 8. Pulizia periodica

I caratteri stampati possono diventare parzialmente poco chiari a causa dell'accumulo di polvere di carta e sporczia. Per evitare tale problema, è necessario rimuovere periodicamente la polvere di carta accumulata nel comparto carta, nella sezione di trasporto carta e sulla superficie della testina termica. Si consiglia di eseguire questa pulizia una volta ogni sei mesi oppure ogni milione di righe stampate.

### 8-1. Pulizia della testina termica

Per rimuovere la polvere nerastra accumulata sulla superficie della testina di stampa, passarla con alcool (IPA)

**Nota:** La testina termica si danneggia facilmente, per cui pulirla delicatamente con un panno morbido. Fare attenzione a non graffiarla durante la pulizia.

### 8-2. Pulizia del comparto carta

Usare un panno morbido per eliminare la polvere di carta dal comparto carta e dalla sezione di trasporto della carta.

# Appendix A: Specifications

## A-1. General Specifications

- |                             |  |
|-----------------------------|--|
| (1) Printing method         | Direct line thermal printing   |
| (2) Print speed             | Max. 800 dots/sec. (100 mm/sec.)   |
| (3) Dot density             | 203 dpi: 8 dots/mm (0.125 mm/dot)  |
| (4) Printing width          | Max. 72 mm   |
| (5) Number of print columns | Max.48 (12 × 24 dots)<br>Max.64 (9 × 24 dots: ESC/POS mode)  |
| (6) Roll paper              | Refer to chapter 2 for details on the recommended roll paper.<br>Paper width: 79.5±0.5 mm or 57.5±0.5 mm (option)<br>Roll diameter: ø90 mm or less |
| (7) Overall dimension       | 142 (W) × 199 (D) × 132 (H) mm   |
| (8) Weight                  | Approx. 1.4 kg   |
| (9) Noise Approx.           | 53 dB (Auto cutter model)/49 dB (Tear bar model)   |

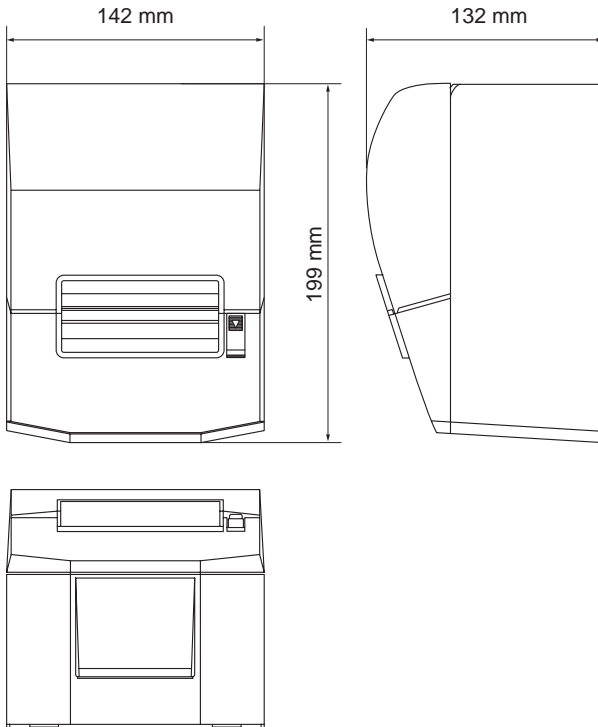

## A-2. Auto Cutter Specifications

- (1) Cutting frequency      Max. 20 cuts per minute
- (2) Thickness of paper      65~85 μm

## A-3. Interface

RS232C serial interface or Two-way parallel interface (IEEE1284)

## A-4. Electrical Characteristics

- (1) Input Voltage      DC 24V±10%
- (2) Current Consumption    Operating: Approx. 1.3 A (at ASCII printing)  
                                  Peak:      Approx. 8 A (at print duty 100%,  
                                  for 10 seconds or less)  
                                  Stand-by: Approx. 0.05 A

(3) Power Connector

Pin No.	Function
1	DC24V
2	Signal GND
3	N.C.
Shell	Frame ground

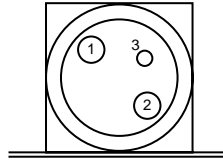

<Viewed from Connector Surface>

### Important!

- When using a printer power supply other than the optional AC adaptor (PS60-24A), be sure that the following cautions are observed.
- Use a power supply of DC 24 V ±10% and more than 2.0 A (5.0 A Load 10 sec. Min) with SELV output approved by IEC60950.
- Be careful about installing the printer in an area where there is noise. Take the appropriate measures to protect against electrostatic AC line noise, etc.

## A-5. Option

- (1) Wall Mount Set (WB-T600)
- (2) Vertical Stand Set (VS-T600)
- (3) USB Interface Board Unit (IFBD-HU04)
- (4) Parallel Interface Board Unit (IFBD-HC04)
- (5) 25 Pin RS-232C Interface Board Unit (IFBD-HD04)
- (6) 9 Pin RS-232C Interface Board Unit (IFBD-HN04)

## A-6. Environmental Requirements

- (1) Operating  
Temperature 5°C to 45°C  
Humidity 10% to 90% RH (without condensation)

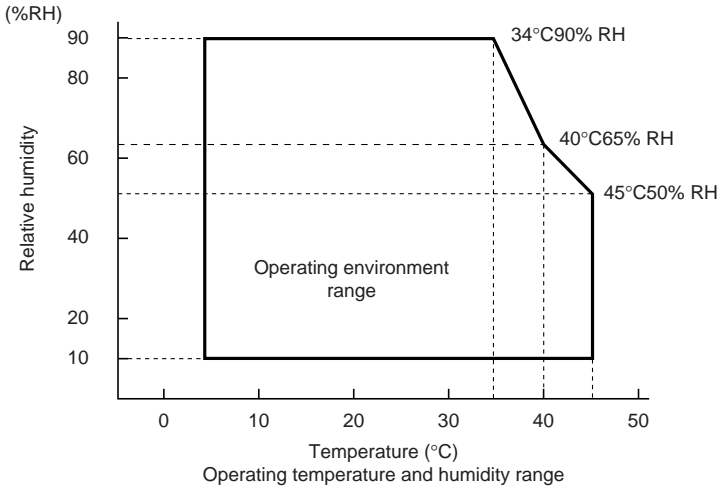

- (2) Transport/storage (except for paper)  
Temperature -20°C to 60°C  
Humidity 10% to 90% RH (without condensation)

## A-7. Reliability

- (1) MCBF 60 million lines (based on an average printing rate of 12.5% with paper thickness in the 65  $\mu\text{m}$ )
- (2) Cutter life 0.5 million cuttings (if the paper thickness is between 65 and 85  $\mu\text{m}$ )

## Appendix B: Dip Switch Setting

Two DIP switches are provided at the bottom of the printer, and can be set as given in the table below. Be sure to set the power switch to off before changing the settings. It is recommended to use a pointed item like a pen or flat-blade driver screw to change the settings. The settings will become effective when the power switch is set to on again.

The following is the procedure for changing the settings on DIP switches.

1. Make sure the printer is turned off.
2. Remove the screw from the DIP switch cover. Then take off the DIP switch cover, as shown in the illustration below.

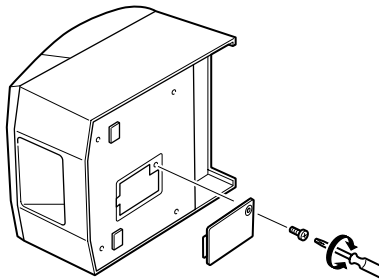

3. Set the switches using a pointed tool, such as a pen or flat-blade screwdriver.
4. Replace the DIP switch cover. Then secure it with the screw. The new settings take effect when you turn on the printer.

## B-1. Parallel Interface Type

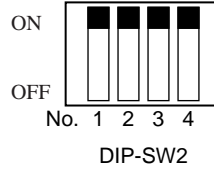
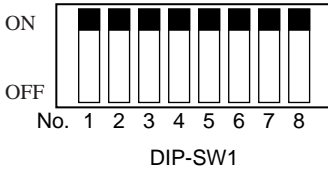

DIP-SW 1

Switch 1-1	Command emulation
ON	Star Mode
OFF	ESC/POS Mode

All factory settings for dipswitch 1 on the auto cutter model are set at [ON]. Switch 1-3 on the tear bar model is set at [OFF], and the others are set at [ON].

The functions of switches 1-2 through 1-8 will change according to the command emulation that has been set using switch 1-1.

### (1) Star mode

Switch	Function	ON	OFF
1-1	Command emulation	Always ON	
1-2	Should not be changed (Should be set to on)		
1-3	Auto cutter	Valid	Invalid
1-4	Sensor adjustment	Invalid	Valid
1-5	Pin #31 (INIT) reset signal	Valid	Invalid
1-6	Handshaking conditions (conditions for BUSY)	Offline or receive buffer full	Receive buffer full
1-7	Automatic status back function	Invalid	Valid
1-8	Should not be changed (Should be set to on)		

### (2) ESC/POS mode

Switch	Function	ON	OFF
1-1	Command emulation	Always OFF	
1-2	Graphic adjustment	203 DPI	180 DPI
1-3	Auto cutter	Valid	Invalid
1-4	Sensor adjustment	Invalid	Valid
1-5	Pin #31 (INIT) reset signal	Valid	Invalid
1-6	Handshaking conditions (conditions for BUSY)	Offline or receive buffer full	Receive buffer full
1-7	Automatic status back function	Invalid	Valid
1-8	Should not be changed (Should be set to on)		

## DIP-SW 2

Switch	Function	ON	OFF
2-1	Always ON		Should be set to on
2-2			
2-3			
2-4			

The factory settings of DIP switch 2 are all on.

## B-2. Serial Interface Type

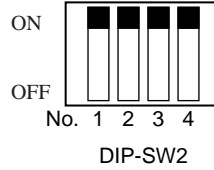
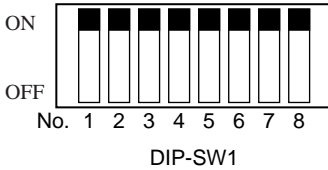

DIP-SW 1

Switch 1-1	Command emulation
ON	Star Mode
OFF	ESC/POS Mode

All factory settings for dipswitch 1 on the auto cutter model are set at [ON]. Switch 1-3 on the tear bar model is set at [OFF], and the others are set at [ON].

The functions of switches 1-2 through 1-8 will change according to the command emulation that has been set using switch 1-1.

### (1) Star mode

Switch	Function	ON	OFF
1-1	Command emulation	Always ON	
1-2	Should not be changed (Should be set to on)		
1-3	Auto cutter	Valid	Invalid
1-4	Sensor adjustment	Invalid	Valid
1-5	Should not be changed (Should be set to on)		
1-6	Handshaking conditions (conditions for BUSY)	Offline or receive buffer full	Receive buffer full
1-7	Automatic status back function	Invalid	Valid
1-8	Should not be changed (Should be set to on)		

### (2) ESC/POS mode

Switch	Function	ON	OFF
1-1	Command emulation	Always OFF	
1-2	Graphic Adjustment	203 DPI	180 DPI
1-3	Auto cutter	Valid	Invalid
1-4	Sensor adjustment	Invalid	Valid
1-5	Should not be changed (Should be set to on)		
1-6	Handshaking conditions (conditions for BUSY)	Offline or receive buffer full	Receive buffer full
1-7	Automatic status back function	Invalid	Valid
1-8	Should not be changed (Should be set to on)		



## DIP-SW 2

Switch	Function	ON	OFF
2-1	Always ON		Should be set to on
2-2			
2-3			
2-4			

The factory settings of DIP switch 2 are all on.

The following is the procedure for changing the settings on DIP switch No. 3.

1. Turn off the printer and all components connected to it.
2. Remove the 2 screws.
3. Remove the serial interface board unit.
4. Change the setting of the DIP switches.
5. Replace the serial interface board unit.  
Then secure it with the screws.
6. Turn on the printer and all components connected to it.

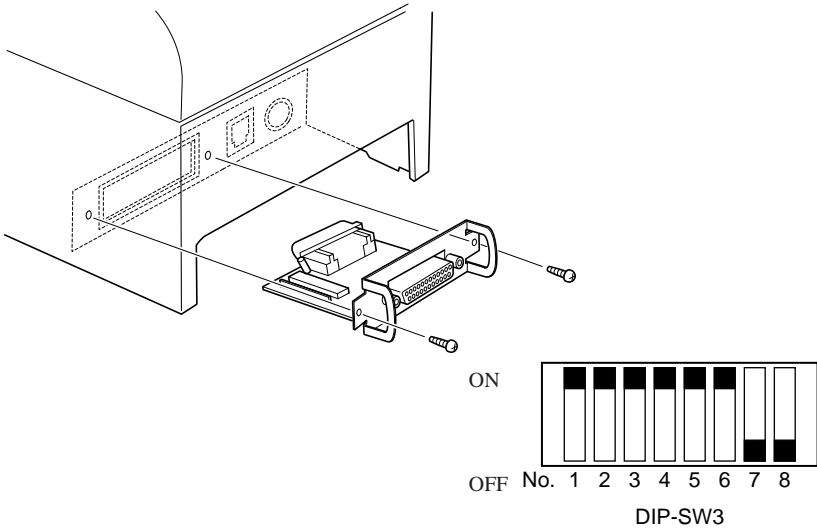

The factory settings of DIP switch are all on, except for switches 7 and 8.

### DIP-SW 3

Switch	Function	ON	OFF
3-1	Baud Rate	See table below	
3-2			
3-3	Data Length	8 bits	7 bits
3-4	Parity Check	Disabled	Enabled
3-5	Parity	Odd	Even
3-6	Handshake	DTR/DSR	XON/XOFF
3-7	Pin #6 (DSR) reset signal	Valid	Invalid
3-8	Pin #25 (INIT) reset signal	Valid	Invalid

Baud Rate	Switch 3-1	Switch 3-2
4800BPS	OFF	ON
9600BPS	ON	ON
19200BPS	ON	OFF

# Appendix C: Parallel Interface

The two-way parallel interface is compatible with the IEEE1284 compatibility mode, nibble mode and byte mode. Refer to the separate programmer’s manual for details.

## Table of Connection Signals for Each Mode

Pin No.	Direction	Compatibility Mode Signal Name	Nibble Mode Signal Name	Byte Mode Signal Name
1	In	nStrobe	Host Clock	Host Clock
2	In/Out	Data0	Data0	Data0
3	In/Out	Data1	Data1	Data1
4	In/Out	Data2	Data2	Data2
5	In/Out	Data3	Data3	Data3
6	In/Out	Data4	Data4	Data4
7	In/Out	Data5	Data5	Data5
8	In/Out	Data6	Data6	Data6
9	In/Out	Data7	Data7	Data7
10	Out	nAck	PtrClk	PtrClk
11	Out	Busy	PtrBusy/Data3,7	PtrBusy
12	Out	PError	AckDataReq/Data2,6	AckDataReq
13	Out	Select	Xflag/Data1,5	Xflag
14	In	—	HostBusy	HostBusy
15		—	—	—
16		Signal GND	Signal GND	Signal GND
17		Frame GND	Frame GND	Frame GND
18	OUT	+5V	+5V	+5V
19~30		Twisted Pair Return	Twisted Pair Return	Twisted Pair Return
31	In	nInit	nInit	nInit
32	Out	nFault	nDataAvail/Data0,4	nDataAvail
33		External GND	—	—
34	Out	Compulsion Status	—	—
35		—	—	—
36	In	nSelectIn	1284Active	1284Active

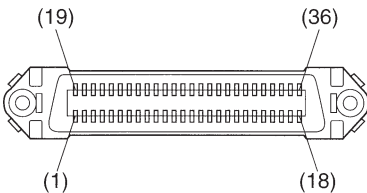

This connector mates with an Amphenol 57-30360 connector

Parallel interface connector (printer side)

# Appendix D: Serial Interface

## D-1. RS-232C Connector

Pin No. 25 Pin	9 Pin	Signal name	Direction	Function
1		F-GND	—	Frame ground
2	3	TXD	OUT	Transmission data
3	2	RXD	IN	Receive data
4	7	RTS	OUT	Same as DTR signal.
5	8	N/C		Not used
6	6	DSR	IN	<p>• <b>DIP Switch 3-7=OFF</b></p> <p><b>STAR Mode</b> Status of this signal is not checked.</p> <p><b>ESC/POS Mode</b> In DTR/DSR communication mode, indicates whether data receive from host is enabled or disabled. Space: Receive enabled Mark: Receive disabled (except when transmitting data by DLE EOT, and GS a) This signal is not checked in the X-ON/X-OFF communication mode.</p> <p>• <b>DIP Switch 3-7=ON</b> This signal used for external reset. Priter is reset whenever signal is in mark state with pulse width of 1mS or more.</p>
7	5	S-GND	—	Signal ground
8~19	1,9	N/C		Not used
20	4	DTR	OUT	<p>Indicates whether data receive from host is enabled or disabled.</p> <p><b>1) DTR/DSR Communication Mode</b></p> <p>This signal indicates whether the printer is busy. SPACE indicates that the printer is ready to receive data, and MARK indicates that the printer is busy. The busy condition can be changed by using DIP SW 1-6 as follows:</p>

Pin No.		Signal name	Direction	Function																										
25 Pin	9 Pin																													
				<table border="1"> <thead> <tr> <th rowspan="2">Printer status</th> <th colspan="2">DIP SW 1-6</th> </tr> <tr> <th>OFF</th> <th>ON</th> </tr> </thead> <tbody> <tr> <td>1. During the period from when the power is turned on (including resetting using the interface) to when the printer is ready to receive data.</td> <td>BUSY</td> <td>BUSY</td> </tr> <tr> <td>2. During the self printing.</td> <td>BUSY</td> <td>BUSY</td> </tr> <tr> <td>3. When the cover is open.</td> <td>-</td> <td>BUSY</td> </tr> <tr> <td>4. When the printer stops printing due to a paper-end.</td> <td>-</td> <td>BUSY</td> </tr> <tr> <td>5. During macro executing standby status.</td> <td>-</td> <td>BUSY</td> </tr> <tr> <td>6. When an error has occurred.</td> <td>-</td> <td>BUSY</td> </tr> <tr> <td>7. When the receive buffer becomes full.</td> <td>BUSY</td> <td>BUSY</td> </tr> </tbody> </table> <p><b>2) X-On/X-Off Communication Mode</b>            Always space, except during following conditions:</p> <ul style="list-style-type: none"> <li>• Period between reset and communication enabled</li> <li>• During self printing</li> </ul>	Printer status	DIP SW 1-6		OFF	ON	1. During the period from when the power is turned on (including resetting using the interface) to when the printer is ready to receive data.	BUSY	BUSY	2. During the self printing.	BUSY	BUSY	3. When the cover is open.	-	BUSY	4. When the printer stops printing due to a paper-end.	-	BUSY	5. During macro executing standby status.	-	BUSY	6. When an error has occurred.	-	BUSY	7. When the receive buffer becomes full.	BUSY	BUSY
Printer status	DIP SW 1-6																													
	OFF	ON																												
1. During the period from when the power is turned on (including resetting using the interface) to when the printer is ready to receive data.	BUSY	BUSY																												
2. During the self printing.	BUSY	BUSY																												
3. When the cover is open.	-	BUSY																												
4. When the printer stops printing due to a paper-end.	-	BUSY																												
5. During macro executing standby status.	-	BUSY																												
6. When an error has occurred.	-	BUSY																												
7. When the receive buffer becomes full.	BUSY	BUSY																												
21~24		N/C		Not used																										
25		INIT	IN	<p>• <b>DIP Switch 3-8=OFF</b>            Status of this signal is not checked.</p> <p>• <b>DIP Switch 3-8=ON</b>            This signal used for external reset. Printer is reset whenever signal is in space state with pulse width of 1mS or more.</p>																										

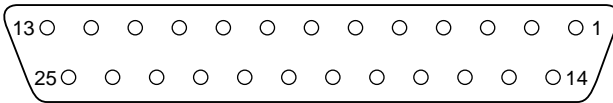

D-sub 25 Pin

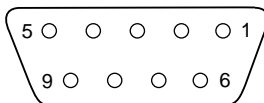

D-sub 9 Pin (option)

## D-2. Cable Connections

The followings are a recommended interface cable connections.

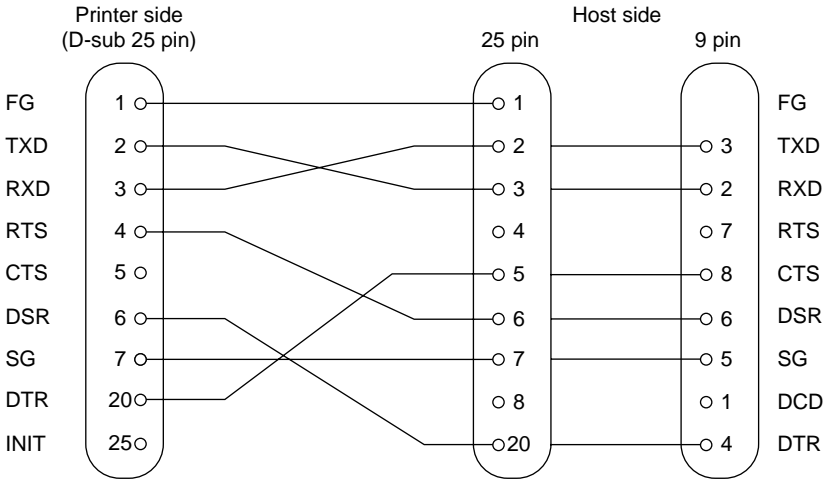

**Note:** Use shielded wire less than 3m in length.

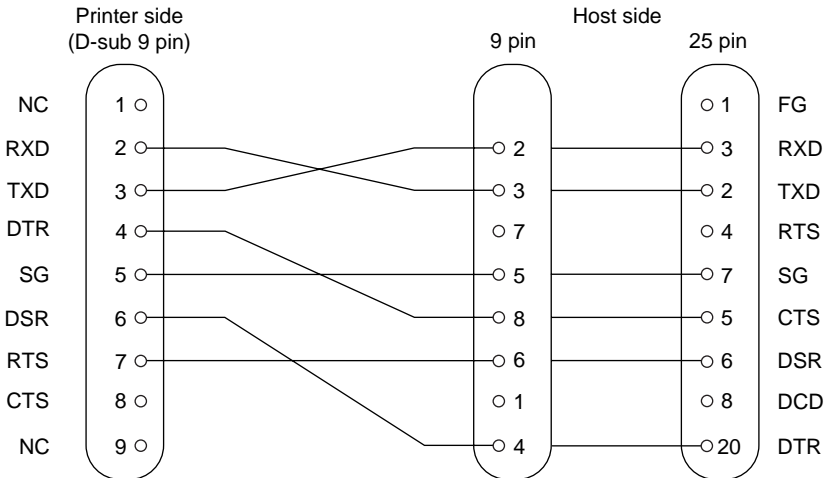

**Note:** Use shielded wire less than 3m in length.

## D-3. Electrical Characteristics

Voltage	Data signal	Control signal	Binary status
-3V to -15V	Mark	OFF	1
+3V to +15V	Space	ON	0

## Appendix E: Peripheral Unit Drive Circuit

Peripheral unit drive circuit connector only connects to peripheral units such as cash drawers, etc.

Do not connect it to a telephone.

Use cables which meet the following specifications.

### Peripheral Drive Connector

Pin No.	Signal name	Function	I/O direction
1	FG	Frame ground	—
2	DRD1	Drive signal 1	OUT
3	+24V	Drive power	OUT
4	+24V	Drive power	OUT
5	DRD2	Drive signal 2	OUT
6	DRSNS	Sense signal	IN

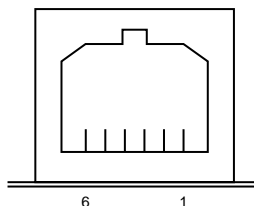

<Viewed from Connector Surface>

### Modular plug

Modular plug: MOLEX 90075-0007,  
AMP641337, or BURNDY B-66-4

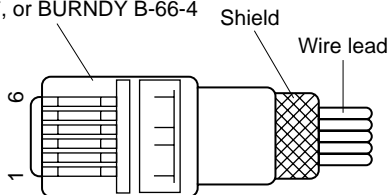

- Notes:**
1. Pin 1 must be shield drain wire connected to peripheral device frame ground.
  2. It is not possible to drive two drives simultaneously.
  3. The peripheral drive duty must satisfy the following:  
ON time / (ON time + OFF time)  $\leq$  0.2
  4. The resistance of the peripheral drive solenoid must be 24  $\Omega$  or higher.  
If it is lower than 24  $\Omega$ , over-current may flow into the solenoid, causing the solenoid to burn.

## Appendix F: Memory Switch Settings

Each memory switch is stored in flash memory. For details on the functions and settings of memory switches, see the separate Programmer's Manual.

The table below shows the factory settings for the memory switches.

Memory Switch	Hexadecimal Code
0	0000
1	0000
2	0000
3	0000
4	0000

---

### ***Warning!***

Changing the memory switch settings can cause the printer to fail to operate correctly.

---





**ELECTRONIC PRODUCTS DIVISION  
STAR MICRONICS CO., LTD.**

536 Nanatsushinnya, Shimizu, Shizuoka,  
424-0066 Japan  
Tel: 0543-47-0112, Fax: 0543-48-5013

Please access the following URL  
[http://www.star-micronics.co.jp/service/  
frame\\_sp\\_spr\\_e.htm](http://www.star-micronics.co.jp/service/frame_sp_spr_e.htm)  
for the latest revision of the manual.

**OVERSEAS SUBSIDIARY COMPANIES  
STAR MICRONICS AMERICA, INC.**

1150 King Georges Post Road, Edison, NJ 08837-3729 U.S.A.  
Tel: 732-623-5555, Fax: 732-623-5590

**STAR MICRONICS U.K. LTD.**

Star House, Peregrine Business Park, Gomm Road,  
High Wycombe, Bucks, HP13 7DL, U.K.  
Tel: 01494-471111, Fax: 01494-473333