

# HITACHI

## Instruction Manual

Video Camcorder  
**VM-6500A**



**HITACHI HOME ELECTRONICS  
(AMERICA), INC.**  
1855 Donroch Court,  
San Diego, California 92173  
Tel. 770-279-5600

**HITACHI (HSC) CANADA INC.**  
6740 Campobello Road  
Mississauga, Ontario L5N 2L8  
CANADA  
Tel. 905-821-4545

Thank you for choosing the  video camcorder. For maximum pleasure and convenience please read these simple instructions before operating your camcorder.

## TABLE OF CONTENTS

PRECAUTIONS.....	3
FEATURES.....	4
ACCESSORIES.....	4
IMPORTANT SAFEGUARDS.....	4
IMPORTANT SAFETY INSTRUCTIONS FOR AC ADAPTOR/CHARGER.....	7
ELECTRONIC VIEWFINDER (EVF).....	8
EYEPIECE ADJUSTMENT.....	8
POWER SOURCES.....	9
CHECKING THE BATTERY.....	10
CHARGING THE BATTERY.....	10
IDENTIFICATION AND OPERATION OF CONTROLS.....	12
INSERTING AND REMOVING CASSETTES.....	15
MAKING A SAMPLE CAMERA RECORDING.....	15
INSTANT REVIEW.....	16
PLAYBACK.....	17
AUTOMATIC REWIND.....	18
DATE/TIME SETTING.....	18
DATE RECORDING.....	20
AUTO FOCUS.....	22
DISPLAY BUTTON.....	23
TAPE COUNTER.....	23
MEMORY.....	23
REMAINING TAPE.....	24
PROGRAM AE (Auto Exposure).....	24
POWER ZOOM.....	24
DIGITAL ZOOM.....	25
MACRO.....	25
QUICK EDIT (Edit Search).....	26
INDEX SIGNAL RECORDING.....	26
TITLE RECORDING.....	26
VIEWING THE PICTURE PLAYED BACK ON YOUR TV.....	29
CAMCORDER TO VCR DUBBING.....	30
ATTACHING THE OPTIONAL TELE OR WIDE CONVERTER LENS.....	31
VIEWFINDER BRIGHT CONTROL.....	31
HOW TO ATTACH THE SHOULDER STRAP.....	31
TROUBLESHOOTING.....	32
PLAYBACK OF PRERECORDED CASSETTE.....	33
CLEANING THE INSIDE OF THE ELECTRONIC VIEWFINDER.....	33
HEAD CLEANING.....	33
PERIODIC MAINTENANCE.....	34
SPECIFICATIONS.....	34
For U.S.A. only.....	34
ACCESSORIES ADD EXCITEMENT.....	35

**WARNING:** TO PREVENT FIRE OR ELECTRIC SHOCK, DO NOT EXPOSE THIS APPLIANCE TO RAIN OR MOISTURE.



**CAUTION:** TO REDUCE RISK OF ELECTRIC SHOCK, DO NOT REMOVE COVER (OR BACK).

NO USER - SERVICEABLE PARTS INSIDE. REFER SERVICING TO QUALIFIED SERVICE PERSONNEL.



This symbol warns the user that uninsulated voltage within the unit may have sufficient magnitude to cause electric shock. Therefore, it is dangerous to make any kind of contact with any inside part of this unit.



This symbol alerts the user that important literature concerning the operation and maintenance of this unit has been included. Therefore, it should be read carefully in order to avoid any problems.

**CAUTION:**

TO PREVENT ELECTRIC SHOCK, MATCH WIDE BLADE OF PLUG TO WIDE SLOT, FULLY INSERT.

This Class B digital apparatus meets all requirements of the Canadian ICES-003.

**Warning:** This device complies with Part 15 of the FCC rules. Operation is subject to the following two conditions: (1) This device may not cause harmful interference, and (2) this device must accept any interference received, including interference that may cause undesired operation.

**Note:** This equipment has been tested and found to comply with the limits for a Class B digital device, pursuant to Part 15 of the FCC Rules. These limits are designed to provide reasonable protection against harmful interference in a residential installation. This equipment generates, uses, and can radiate radio frequency energy and, if not installed and used in accordance with the instructions, may cause harmful interference to radio communications. However, there is no guarantee that interference will not occur in a particular installation. If this equipment does cause harmful interference to radio or television reception, which can be determined by turning the equipment off and on, the user is encouraged to try to correct by one or more of the following measures:

- Reorient or relocate the receiving antenna.
- Increase the separation between the equipment and the receiver.
- Connect the equipment into an outlet on a circuit different from that to which the receiver is connected.
- Consult the dealer or an experienced radio/TV technician for help.

**Caution to the user:** Changes or modifications not expressly approved by the manufacturer could void the user's authority to operate the equipment.

**Caution:** Avoid operating your camcorder immediately after moving it from a cold area to a warm humid area. Give the camcorder 2 to 3 hours to acclimate to the surroundings before inserting a video cassette. When moved from a cold area to a warm humid area, moisture may condense on the head drum inside the machine. This moisture could cause the tape to stick to the headwheel and damage the headwheel or tape.

See the bottom of the AC adaptor/charger. The rating and caution label is located on the bottom of the AC adaptor/charger.

**WARNING:** Many television programs and films are copyrighted. In certain circumstances, copyright law may apply to private in-home videotaping of copyrighted materials.

## PRECAUTIONS

Any problems that occur as a result of any of the following conditions will not be covered by our warranty.

- Be careful that no water, dust, or sand enters the camcorder.
- When you are not using the camcorder, switch off the power and attach the lens cap.
- When you shoot at a scene which contains an extremely bright object such as the sun or a light source, a bright vertical bar may appear in the picture.

Your camcorder is functioning properly, but the solid-state pickup device (CCD) usually causes this as an inherent characteristic. Try to avoid shooting an excessive bright object directly.

- Be sure not to leave the camcorder in a place where the temperature exceeds 140°F (60°C), or the pickup

device may be damaged.

Dangerous includes:

- Inside a car with the windows closed and in direct sunshine.
- Near heating appliances.
- Do not point the electronic viewfinder to direct sunlight; it could damage the viewfinder.
- The liquid crystal display (LCD) panel is made by highly precise technology. More than 99.99% of its picture elements (pixels) are effective, but some (less than 0.01%) may not appear as coloured bright dots. This does not indicate a fault as the LCD panel stretches the limits of current technology.

## FEATURES

- Digital zoom up to X72
- Solid-state camera pickup
- **HQ** High Quality picture technology
- Auto Focus power zoom lens with macro feature
- Full record and playback capability with standard **VHS** cassette
- Program AE (Auto Exposure)
- Color electronic viewfinder (EVF)
- Time and date
- Titler
- Index symbol recording

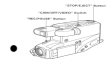

- **This video camcorder with this marking incorporates **VHS** high-quality picture technology and is compatible with any video cassette recorder bearing the **VHS** mark.**

## ACCESSORIES

Check to make sure you have the following components and accessories (besides the camcorder unit itself) before disposing of the packing material.

1. Lead-acid rechargeable battery
2. AC adaptor/charger
3. Shoulder strap
4. DC cord

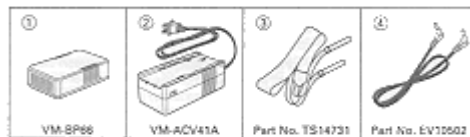

## IMPORTANT SAFEGUARDS

In addition to the careful attention devoted to quality standards in the manufacture of your video product, safety is a major factor in the design of every instrument. But, safety is your responsibility too.

This page lists important information that will help to assure your enjoyment and proper use of a Video Camcorder and accessory equipment. Please read it carefully before operating your video product and keep it in a handy place for future reference.

### INSTALLATION

**1 Read and Follow Instructions** -- All the safety and operating instructions should be read before the video product is operated. Follow all operating and use instructions.



**2 Retain Instruction** -- The safety and operating instructions should be retained for future reference.

**3 Heed Warnings** -- Comply with all warnings on the video product and in the operating instructions.

**4 Polarized Plug** -- This video product is equipped with a polarized alternating-current line plug (a plug having one blade wider than the other). This plug will fit into the power outlet only one way. This is a safety feature. If you are unable to insert the plug fully into the outlet, try reversing the plug. If the plug should still fail to fit, contact your electrician to replace your obsolete outlet. To prevent electric shock do not use this polarized plug with an extension cord, receptacle or other outlet unless the blades can be fully inserted without blade exposure. If you need an extension, use a polarized cord.



**5 Power Sources** -- This video product should be operated only from the type of power source indicated on the marking label. If you are not sure of the type of power supply to your home, consult your video dealer or local power company. For video products intended to operate from battery power, or other sources, refer to the operating instructions.

**6 Overloading** -- Do not overload wall outlets and extension cords as this can result in a risk of fire or electric shock. Overloaded AC outlets and extension cords are dangerous, and so are frayed power cords, damaged or cracked wire insulation and broken plugs. They may result in shock or fire hazard. Periodically examine the cord and have it replaced by your service technician if appearance indicates damage or deteriorated insulation.

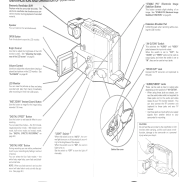

**7 Power Cord Protection** -- Power supply cords should be routed so that they are not likely to be walked on or pinched by items placed upon or against them, paying particular attention to cords at plugs, convenience receptacles, and the point where they exit from the appliance.

**8 Ventilation** -- Slots and openings in the cabinet are provided for ventilation to ensure reliable operation of the video product and to protect it from overheating. These openings must not be blocked or covered. The openings should never be blocked by placing the video product on a bed, sofa, rug or other similar surface. This video product should never be placed near or over a radiator or heat register. This video product should not be placed in a built-in installation such as a bookcase or rack unless proper ventilation is provided or the video product manufacturer's instructions have been followed.

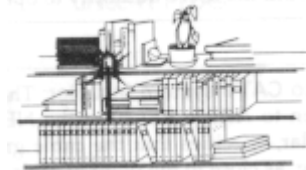

**9 Attachments** -- Do not use attachments unless recommended by the video product manufacturer as they may cause hazards.

**Caution:** Maintain electrical safety. Power-line operated equipment or accessories connected to this unit should bear the UL listing mark or CSA certification mark on the accessory itself and should not have been modified so as to defeat the safety features. This will help avoid any potential hazard from electric shock or fire. If in doubt, contact qualified service personnel.

**10 Water and Moisture** -- Do not use this video product near water -- for example, near a bath tub, wash bowl,

kitchen sink, or laundry tub, in a wet basement, or near a swimming pool, and the like.

**11 Accessories** -- Do not place this video product on an unstable card, stand, tripod, bracket or table. The video product may fall, causing serious injury to a child or adult, and serious damage to the appliance. Use only with a cart, stand, tripod, bracket or table recommended by the manufacturer, or sold with the video product. Any mounting of the product should follow the manufacturer's instructions, and should use a mounting accessory recommended by the manufacturer.

**11A** An appliance and cart combination should be moved with care. Quick stops, excessive force, and uneven surfaces may cause the appliance and cart combination to overturn.



**12 Outdoor Antenna Grounding** -- If an outside antenna or cable system is connected to the video product, be sure the antenna or cable system is grounded so as to provide some protection against voltage surges and built-up static charges. Section 810 of the National Electrical Code, ANSI/NFPA No. 70, provides information with respect to proper grounding of the mast and supporting structure, grounding of the lead-in wire to an antenna discharge unit, size of grounding conductors, location of antenna-discharge unit, connection to grounding electrodes, and requirements for the grounding electrode. See example below:

**EXAMPLE OF ANTENNA GROUNDING**

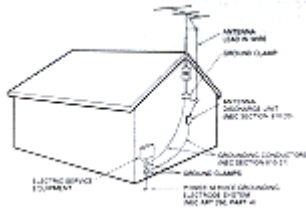

**13 Power Lines** -- An outside antenna system should not be located in the vicinity of overhead power lines or other electric light or power circuits, or where it can fall into such power lines or circuits. When installing an outside antenna system, extreme care should be taken to keep from touching or approaching such power lines or circuits as contact with them might be fatal. Installing an outdoor antenna can be hazardous and should be left to a professional antenna installer.

**USE**

**14 Cleaning** -- Unplug this video product from the wall outlet before cleaning. Do not use liquid cleaners or aerosol cleaners. Use a damp cloth for cleaning.

**15 Object and Liquid Entry** -- Never push objects of any kind into this video product through openings as they may touch dangerous voltage points or short-out parts that could result in a fire or electric shock. Never spill liquid of any kind on the video product.

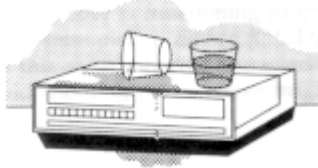

**16 Lightning** -- For added protection for this video product during a lightning storm, or when it is left unattended and unused for long periods of time, unplug it from the wall outlet and disconnect the antenna or cable-system. This will prevent damage to the video product due to lightning and power-line surges.



## SERVICE

**17 Servicing** -- Do not attempt to service this video product yourself as opening or removing covers may expose you to dangerous voltage or other hazards. Refer all servicing to qualified service personnel.

**18 Conditions Requiring Service** -- Unplug this video product from the wall outlet and refer servicing to qualified service personnel under the following conditions.

- a. When the power-supply cord or plug is damaged
- b. If liquid has been spilled or objects have fallen into the video product.
- c. If the video product has been exposed to rain or water.
- d. If the video product does not operate normally by following the operating instructions. Adjust only those controls that are covered by the operating instructions. Improper adjustment of other controls may result in damage and will often require extensive work by a qualified technician to restore the video product to its normal operation.
- e. If the video product has been dropped or the cabinet has been damaged.
- f. When the video product exhibits a distinct change in performance -- this indicates a need for service.

**19 Replacement Parts** -- When replacement parts are required, have the service technician verify that the replacements he uses have the same safety characteristics as the original parts. Use of replacements specified by the video product manufacturer can prevent fire, electric shock or other hazards

**20 Safety Check** -- Upon completion of any service or repairs to this video product, ask the service technician to perform safety checks recommended by the manufacturer to determine that the video product is in safe operating condition.

**21 Heat** -- The product should be situated away from heat sources such as radiators, heat registers, stoves, or other products (including amplifiers) that produce heat.

## IMPORTANT SAFETY INSTRUCTIONS FOR AC ADAPTOR/CHARGER

1. **Save these instructions**--This page contains important safety and operating instructions for AC Adaptor/Charger Model VM-ACV21A.

2. Before using AC Adaptor/Charger, read all instructions and cautionary markings on (1) AC Adaptor/Charger, (2) battery and (3) product using battery.

3. Also read all instructions on pages 4 and 5.

4. **Caution**--To reduce the risk of injury, charge only rechargeable battery, VM-BP64/BP65/BP66/BP67. Other types of batteries may burst causing personal injury and damage.

5. Do not expose charger to rain or snow.

6. Use of an attachment not recommended or sold by the battery charger manufacturer may result in a risk of fire, electric shock, or injury to persons.

7. To reduce the risk of damage to electric plug and cord, pull by plug rather than cord when disconnecting charger.

8. Make sure cord is located so that it will not be stepped on, tripped over, or otherwise subjected to damage or stress.

9. Do not operate charger with damaged cord or plug — replace them immediately.

10. An extension cord should not be used unless absolutely necessary.

Use of improper extension cord could result in a risk of fire and electric shock. If extension cord must be used, make sure:

A. That the pins on plug of extension cord are the same number, size, and shape as those of plug on charger.

B. That extension cord is properly wired and in good electrical condition; and

C. That wire size should be met below:

Minimum AWG size	Length of extension cord (feet)
18	Equal to or less than 100
16	Equal to or less than 150

11. Do not operate charger if it has received a sharp blow, been dropped, or otherwise damaged in any way; take it to a qualified serviceman.

12. Do not disassemble charger; take it to a qualified serviceman when service or repair is required. Incorrect reassembly may result in a risk of electric shock or fire.

13. To reduce the risk of electric shock, unplug charger from outlet before attempting any maintenance or

cleaning.

**"Note to CATV system installer:** This reminder is provided to call the CATV system installer's attention to Article 820-40 of the NEC that provides guidelines for proper grounding and, in particular, specifies that the cable ground shall be connected to the grounding system of the building, as close to the point of cable entry as practical".

## ELECTRONIC VIEWFINDER (EVF)

☐ Set the viewfinder to the position shown in the figure when carrying the camcorder or storing it in the carrying case.

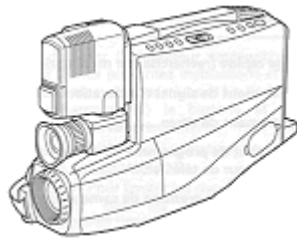

☐ Turn the viewfinder to the position shown below when shooting pictures.

1. Turn the viewfinder.

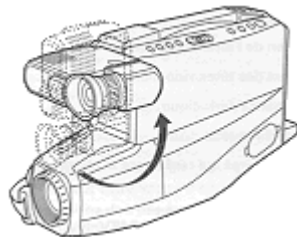

2. Turn the eyepiece.

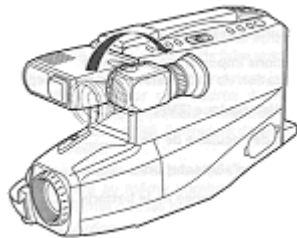

☐ You can adjust the position and angle of the viewfinder so you can see through it easily.

### CAUTIONS:

- Do not force the viewfinder to rotate completely around. This will damage the viewfinder and/or camcorder.
- When pulling the viewfinder out or returning it to its original position, hold the viewfinder by the swivel section. Do not hold the diopter control side.

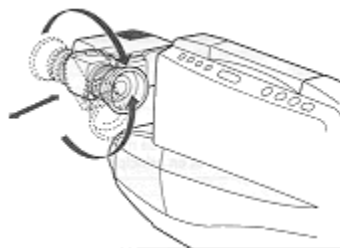

## EYEPIECE ADJUSTMENT



To use the electronic viewfinder without eyeglasses on, adjust the diopter control for optimum focus adjustment.

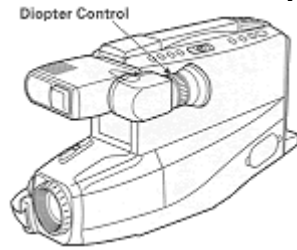

## POWER SOURCES

### □ WHEN USING WITH THE BATTERY (Provided)

• To attach, align the mark "▶" of the battery with that of the camcorder so that the battery fits into the grooves, and slide the battery downward, as illustrated.

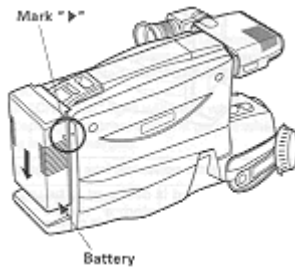

• To remove the battery:  
Push and hold "**BATTERY EJECT**" lever, then slide the battery to the upside and remove.

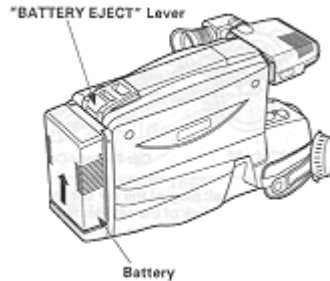

### □ WHEN USING WITH THE AC ADAPTOR/CHARGER (Provided)



1. Plug the AC adaptor/charger power cord into AC electrical outlet.
2. Connect one end of the DC cord (provided) to the "**DC IN 9.6V**" jack of the camcorder. Connect the other end of the DC cord to the "**DC OUTPUT**" of the AC adaptor/charger.

### NOTES:

- The AC adaptor/charger cannot charge the battery and operate the camcorder at the same time.
- When using the AC adaptor/charger to power the camcorder, the battery level indicator may display "☐". This indicator is used for battery operation and has no meaning when using the AC adaptor/charger to power the camcorder.

### □ WHEN USING WITH THE CAR BATTERY (By using optional car battery cord Hitachi VM-CC70A)

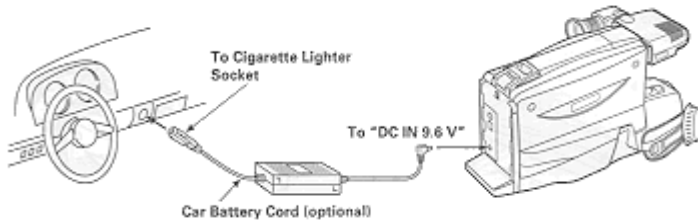

1. Connect the small plug of the car battery cord to the **"DC IN 9.6V"** jack of the camcorder.
2. Connect the other end of the car battery cord to the car's cigarette lighter socket.

#### NOTES:



- The car battery cord is designed to be used only with automobiles having a 12-volt negative ground system.
- To prevent fire or shock hazard or damage to your camcorder, please use only the specified car battery cord.

## CHECKING THE BATTERY

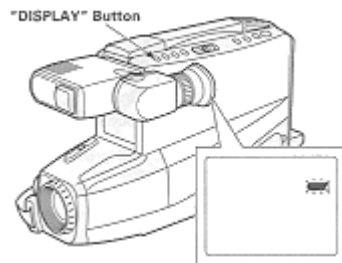
When the "  " indication appears in the viewfinder and flashes while the camcorder is being operated with a battery (provided), it indicates that the battery charge is low. Charge it or replace it with a charged battery.



Press the **"DISPLAY"** button. The remaining battery power level will appear in the viewfinder.

When the battery is fully charged, "  " is displayed. After several minutes, the symbol will change to "  ".

When the battery is very near empty, the symbol will change to "  " and start blinking. You should find an alternative power source or recharge the battery before continuing to use your camcorder.



**NOTE:** When a battery pack is used to power the camcorder, "  " flashes even if **"DISPLAY"** is not pressed to warn you that the battery power level is low.

## CHARGING THE BATTERY

1. Plug the AC adaptor/charger power cord into AC electrical outlet.
2. Attach the battery to the AC adaptor/charger. Align the mark "  " on the battery with that of AC adaptor/charger and push the battery flush with the AC adaptor/charger and slide it in the direction of arrow.

**NOTE:** You must remove the DC cord from the AC adaptor/charger to charge the battery. If the DC cord is connected, the **"CHARGE"** light will not light.

3. The **"CHARGE"** light will be lit while the battery is accepting a charge, and will go out when the battery is fully charged.

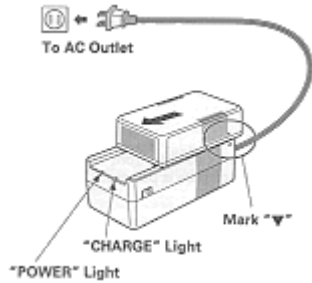

### Charging time and operation time

Charging time	about 2 hours
Operation time	about 1 hour

#### NOTES:

- The operation time depends on how often you use zoom and recording pause.
  - Charge the battery after use and store it at normal room temperature.
  - Recharge your battery at least once every six months. The battery is a lead-acid battery. This battery tends to discharge if not used for an extended period of time. If the battery is stored for a extended length of time without being recharged, you may not be able to recharge it.
  - A battery charged after being stored for a long period may not supply power for the specified time. Additional rechargings will help restore the battery's operation time.
  - The battery should be charged at a temperature of 50 degrees F - 86 degrees F (10 degrees C - 30 degrees C to prevent damage.
  - Do not operate the battery at temperatures below 14 degrees F -10 degrees C or above 95 degrees F (35 degrees C). The battery may be damaged if operated at temperatures above 122 degrees F (50oC). Operation time will decrease at extremely low temperatures,
  - After repeated chargings and use, the operation time will gradually decrease. When operation time becomes too short to be useful, it is time to replace the battery.
  - If the "**CHARGE**" light on the AC adaptor/ charger starts flashing, remove the battery and then reattach it. If after several attempts the light continues to flash, this means your battery cannot take a charge and must be replaced with a new one.
- The "**CHARGE**" light will not light if a hot battery is attached to the AC adaptor/charger. Attaching an extremely hot battery to the AC adaptor/charger is not recommended; it should be allowed to cool down before being attached.
- Do not short the battery's terminal.
  - Do not attempt to disassemble or modify the battery. There are no user serviceable parts inside.
  - Throwing the battery into a fire or exposing the battery to excessive heat - over 149 degrees F (65 degrees C) could be hazardous.

#### ATTENTION:

The product you have purchased is powered by a sealed lead acid battery which is recyclable. At the end of its useful life, under various state and local laws, it is illegal to dispose of this battery into your municipal waste stream.

Please call 1-800-HITACHI for information on how to recycle this battery.



**Pb**

## IDENTIFICATION AND OPERATION OF CONTROLS

[Click here for diagram.](#)

### 1 Diopter Control

Use this control to focus the viewfinder.

### 2 Microphone

Sensitive to sounds coming from the direction in which the camera is pointed.

### 3 Lens (with Lens Cap)

F1.4 (4 ~ 64 mm) 16:1 power zoom lens features auto focus and auto iris functions.

### 4 Color Electronic Viewfinder (EVF)

Displays what the camcorder lens sees. The electronic viewfinder also functions as a convenient monitor during playback of recorded material.

### 5 "RF DC OUT" Jack

Connect the RF converter unit (optional) to this jack.

### 6 "AUDIO/VIDEO" Jacks

Connect the audio/video cable (not supplied) to these jacks and to the audio and video inputs of your TV/monitor receiver. You can also connect the RF converter unit (optional) to these jacks and your TV receiver.

**CAUTION:** Do not hold the unit by the viewfinder when carrying as this could cause a malfunction.

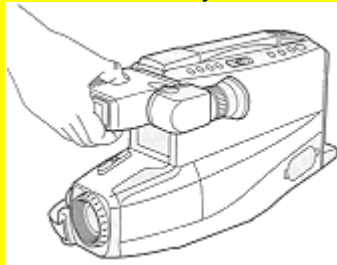

[Click here for diagram.](#)

### 7 "TITLE" Button

Press this button to create and record personalized titles on your videos with the camcorder's built-in titler. (See **"TITLE RECORDING"** on page 28.)

### 8 "DATE/TIME" Button

Press this button to display the date and time in the viewfinder. Whenever the date and time appear in the viewfinder, they will be recorded on the tape.

### 9 "RESET" Button

When the tape counter is displayed in the viewfinder, pressing this button resets the counter to "0000".

### 10 "DISPLAY" Button

If this button is pressed, the tape counter, remaining battery power level, etc. appear in the viewfinder and the tape's 0000M position is stored in memory. If the camcorder is connected to a TV/monitor receiver, the same display as that in the viewfinder appears on the screen. (See **"DISPLAY BUTTON"** and **"MEMORY"** on page 25.)

### 11 "CAM/OFF/VIDEO" Switch

This switch turns the camcorder on and off. Set the switch to **"CAM"** for camera recording, and to **"VIDEO"** for playback.

Press and hold the small button on this switch, and then slide it to **"CAM"** or **"VIDEO"**.

## 12

- These buttons are used for title making buttons when **"TITLE"** is pressed. (See **"TITLE RECORDING"** on page 28.)
- These buttons may be also used to set the date and time during pause (stand-by) mode. (See **"DATE/TIME SETTING"** on page 22.)

## 13 "REW/REVIEW" Button

Press this button during stop or fast forward mode, and fast-rewinding starts. "  " appears in the viewfinder. Press the button during playback of tape, and the tape is played back in the rewind direction approximately 3 times faster than the normal speed to confirm the recorded contents. Press **"PLAY"** to return to normal playback mode or press **"STOP/EJECT"** to stop tape movement.

**NOTE:** You can also visually scan backward when the camcorder is in record/pause (stand-by) mode by pressing and holding this button. Furthermore, use this button to review the last few seconds of the tape you are recording. See page 19.

## 14 "STOP/EJECT" Button

- **"STOP/EJECT"** is used to stop playback, rewind, and fast forward operations. "STOP/EJECT" has no effect during record operation.
- This button is used in the stop mode to open the cassette holder.

## 15 "F.FWD" Button

Press this button during stop or rewind mode, and fast-forwarding starts. "  " appears in the viewfinder. Press the button during playback of tape, and the tape is played back in the forward direction approximately 3 times faster than the normal speed to confirm the recorded content. Press **"PLAY"** to return to normal playback mode or press **"STOP/EJECT"** to stop tape movement.

**NOTE:** You can also visually scan forward when the camcorder is in record/pause (stand-by) mode by pressing and holding this button.

## 16 "PLAY" Button

Used for playback of tape recorded in the SP mode.

**NOTE:** When the camcorder is in record/ pause (stand-by) mode, pressing and holding this button will play the tape at normal speed.

Click here for diagram.

## 17 "BATTERY EJECT" Lever

Releases the battery attached to the video camcorder.

## 18 Cassette Holder

Press **"STOP/EJECT"** in the stop mode to open the cassette holder. Be aware of the cassette direction when inserting.





**NOTE:** Power source must be connected to open the cassette holder.

## 19 "DC IN 9.6V" Jack

When using the AC adaptor/charger (provided) or the car battery cord (optional), connect this jack and the **"DC OUTPUT"** of the AC adaptor/charger or the car battery cord.

## Graphics in the electronic viewfinder



- Displays the shutter speed according to the lightning condition.
- **"ZOOM"** appears when the digital zoom is engaged.
- Displays the zoom position for several seconds when the power zoom switch is operated.
- Indicates the operating modes;
  - **"REC"** appears during the record mode.
  -  appears during the rewind mode.
  -  appears during the fast forward mode.
  -  appears during the record/pause (stand-by) mode.
- Shows tape counter.
- Displays the remaining tape in seven steps.
- Indicates the battery condition;
  - When the battery is fully charged,  is displayed. When the battery is very near empty,  starts blinking. You should find an alternative power source or recharge the battery.
- Appears when the index signal is recorded automatically.
- When **"REC/PAUSE"** is pressed, if a cassette without its safety tab is inserted, **"TAPE"** blinks for several seconds. When **"REC/PAUSE"** is pressed, if no cassette is inserted, **"NO TAPE"** blinks for several seconds.
- Indicates the date/time during the record or record/pause (stand-by) mode. You can record the time and/or date with object when recording.

## 20 "REC/PAUSE" Button

This button is used to control the camcorder. When this button is pressed with the camcorder set to the recording mode, the tape runs to start recording. **"REC"** appears in the viewfinder.

When this button is pressed again,  appears instead of **"REC"** and the tape stops and the camcorder enters the record/ pause (stand-by) mode.

**NOTE:** This button may be also used to display a still picture during playback mode.

## 21 Power Zoom Switch/"TRACKING" Control

- This switch performs zooming electrically.
  - "W"**: Picture becomes wider gradually.
  - "T"**: Picture becomes telescopic gradually.
- Used when playing a tape recorded on another VCR. Adjust for best picture. Ejecting the cassette returns the tracking to the normal position.

## 22 Lens Cap Tab

- Place the lens cap on this tab when you are ready to record a scene. The tab also prevents the lens cap from swinging around on its cord.

## 23 Hand Strap

Adjust to best fit to your hand.

## 24 "BRIGHT" Control

Use to adjust the viewfinder brightness. See page 33.

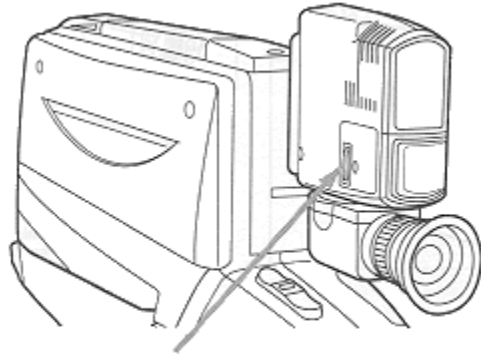

24

## INSERTING AND REMOVING CASSETTES

A power source must be connected before inserting or removing cassettes. Once connected, cassettes can be inserted or removed whether the CAM/OFF/VIDEO switch is on or off.

### Inserting a cassette

1. Connect the POWER SOURCE. (See pages 9 and 10.)
2. Press "**STOP/EJECT**". The cassette door will open automatically.
3. Insert the cassette so the transparent window is toward you and the arrow toward the cassette holder. Slide the cassette into cassette holder as far as it will go.

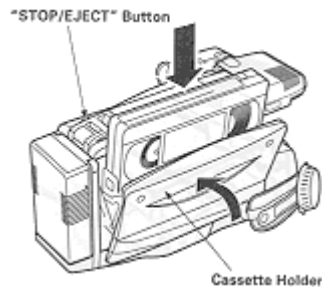

**NOTE:** Push in the center of the cassette all the way until it is latched by the cassette holder.

4. Press the cassette holder. The holder will latch in the operating position.

### Removing a cassette

Press "**STOP/EJECT**". The cassette door will open automatically. Remove the cassette.

## MAKING A SAMPLE CAMERA RECORDING

1. Connect the POWER SOURCE. (See pages 9 and 10.)
2. Insert the cassette.
3. Press and hold the small button on "**CAM/ OFF/VIDEO**", and then slide it to the "**CAM**" position. The camcorder will enter record/pause mode automatically.

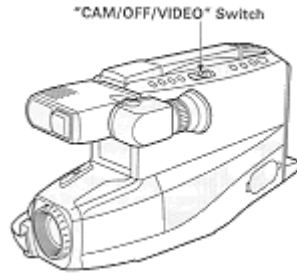

**NOTES:**

- If the erase prevention tab on the cassette is removed, the **"TAPE"** indication in the viewfinder flashes for several seconds and the camcorder will not enter record/pause mode.
- See page 8 for **"EYEPiece ADJUSTMENT"**.

4. Now, press **"REC/PAUSE"** to start shooting the picture. The **"REC"** indication appears in the viewfinder and you are now recording the picture you see through the viewfinder.

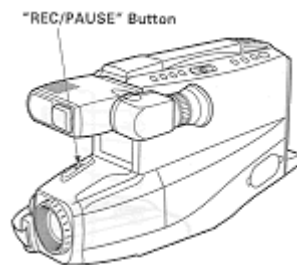

5. Press **"REC/PAUSE"** to stop recording. Press the button again to resume recording. The **"⏏"** indication will appear in the viewfinder instead of **"REC"** while the camcorder is in the record/pause (stand-by) mode.

**NOTES:**

- The **"TAPE END"** indication starts flashing in the viewfinder when there is about five minutes recording time left on the cassette.
- If the record/pause mode continues for more than 5 minutes, the camcorder's power is automatically turned off. To turn on again, press **"REC/PAUSE"**. The camcorder enters record/ pause (stand-by) mode.

6. Slide **"CAM/OFF/VIDEO"** to **"OFF"** position to turn off the camcorder.
7. Press **"STOP/EJECT"** to remove the cassette.
8. Always remove the power source from the camcorder after use.

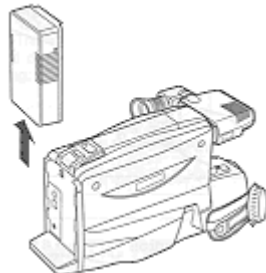

**NOTE:** If you have a cassette tape that has already been partially recorded on and you want to record the remaining blank section, see **"QUICK EDIT"** on page 27.

## INSTANT REVIEW

1. In record/pause (stand-by) mode, tap **"REW/ REVIEW"**, and the last few seconds of the recorded scene is



played back in the reverse direction and then played back in the forward direction.  
2. When the tape reaches the end of the scene you have just recorded, the camcorder returns to the record/pause (stand-by) mode.  
Recording starts again when **"REC/PAUSE"** is pressed again.



**NOTE:** When "REW/REVIEW" is pressed once, the camcorder enters the instant review mode, and when it is held depressed, the camcorder enters the quick edit mode.

## PLAYBACK

You can view recorded pictures with the electronic viewfinder.

**NOTE:** If you connect the camcorder to your TV, you can see the picture played back on your TV. Refer to **"VIEWING THE PICTURE PLAYED BACK ON YOUR TV"** on page 30.

1. Press and hold the small button on **"CAM/OFF/ VIDEO"**, and then slide it to the **"VIDEO"** position.
2. Press **"REW/REVIEW"** to the position where you want to start playback.
3. Press **"PLAY"** and play back the tape.

**NOTE:** Adjust TRACKING if necessary. See **"Tracking adjustment"** on page 30.

4. Press **"STOP/EJECT"** when you have finished.

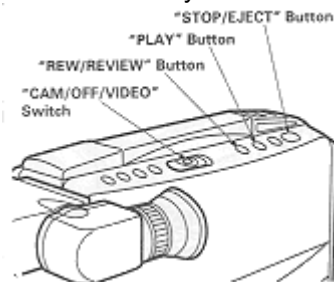

### Still

When **"REC/PAUSE"** is pressed during playback, a still picture can be seen. To start again press **"REC/PAUSE"** and playback will be resumed.

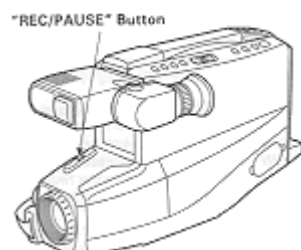

**NOTE:** There will be some noise (interference) in the still picture.



## Forward and Reverse Search

When you press **"F.FWD"** or **"REW/REVIEW"** during playback, the tape will be played back at a speed about 3 times faster than the normal playback speed, and you can easily locate a certain spot on the tape. Press **"PLAY"** to return to normal playback mode or press **"STOP/EJECT"** to stop tape movement.

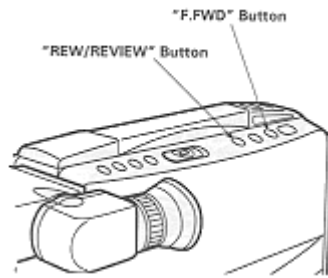

**NOTE:** There will be some noise (interference) in the forward or reverse search pictures while visually scanning.



## AUTOMATIC REWIND

When the tape reaches its end during playback, it automatically rewinds to the beginning and stops.

## DATE/TIME SETTING

The date and time can be recorded on your tapes to act as a handy reference when viewing them at a later time.

Use the following procedure to set up this display for the current date and time.

The time backup battery is rechargeable. Charge the backup battery every two months. Set **"CAM/OFF/VIDEO"** to **"OFF"** position and connect a charged battery or AC adaptor/charger to the camcorder for 24 hours.

Make sure that the current time is displayed correctly before you start recording.

### NOTES:

- The backup battery should be charged every two months. If it is not charged periodically, it will be over-discharged and its life will be shortened.
- A cassette cannot be loaded or ejected when setting the date and time.

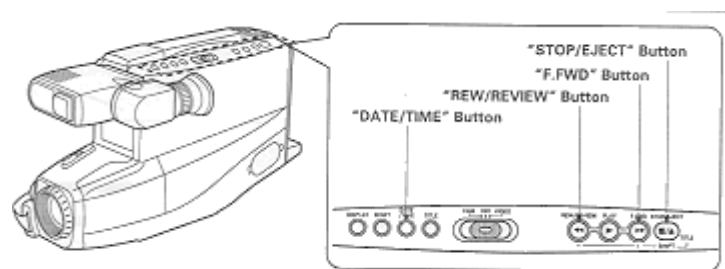

1. Press and hold the small button on **"CAM/OFF/VIDEO"**, and then slide it to **"CAM"** position.

2. Press **"DATE/TIME"**.

Date and time appear in the viewfinder and "1" flashes.



3. Press **"F.FWD"** to select correct month. Hold button down to advance rapidly. If you go past the month you want to set, press **"REW/REVIEW"**. When the correct month appears, press **"STOP/EJECT"**.

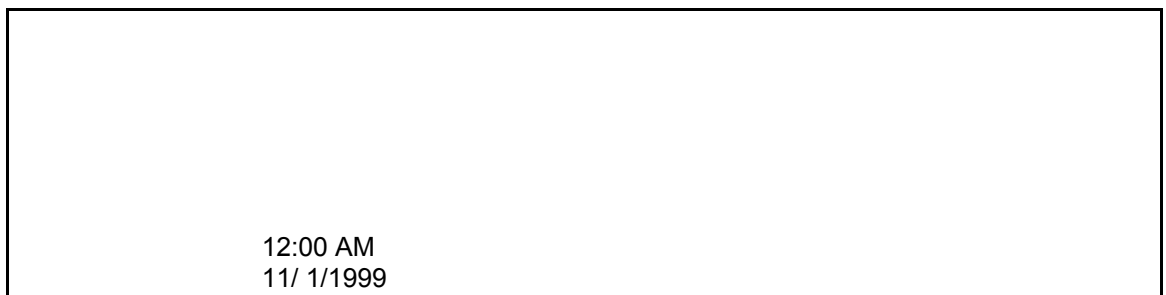

4. Press **"F.FWD"** to select correct date. Hold button down to advance rapidly. If you go past the date you want to set, press **"REW/REVIEW"**. When the correct date appears, press **"STOP/EJECT"**.



5. Press **"F.FWD"** or **"REW/REVIEW"** to select year, and then press **"STOP/EJECT"**.



6. Press **"F.FWD"** or **"REW/REVIEW"** as many times as may be required to select correct hour, and then press **"STOP/EJECT"**.

7. Repeat step 6 to select minute and AM/PM.





8. After setting AM or PM, press "DATE/TIME" to change the display and start the internal clock. It is recommended that you press "DATE/TIME" to match the time signal.

**NOTE:** After the date and time are set, " AUTO" appears and the camcorder enters the automatic date recording mode. See "DATE RECORDING" on page 23.

- To correct date/time information after starting the date/time**
  1. Press and hold "DATE/TIME", and then press "STOP/EJECT". The month starts flashing.
  2. Correct the incorrect digit by using "F.FWD", "REW/REVIEW" and "STOP/EJECT".
- To correct date/time information during programming**  
 Press "STOP/EJECT" repeatedly until the digit that is incorrect flashes. Correct the incorrect digit by using "F.FWD", "REW/REVIEW" and "STOP/ EJECT".

## DATE RECORDING

When the date has been set, the camcorder will enter the automatic date recording mode automatically. Specify the required date mode option before recording.

1. Press and hold the small button on "CAM/OFF/ VIDEO", and then slide it to "CAM" position.
2. Press "DATE/TIME" repeatedly to select the date display you want to record.

### AUTO and date - Automatic date recording

This option records the date automatically once a day at the beginning of recording for 10 seconds.

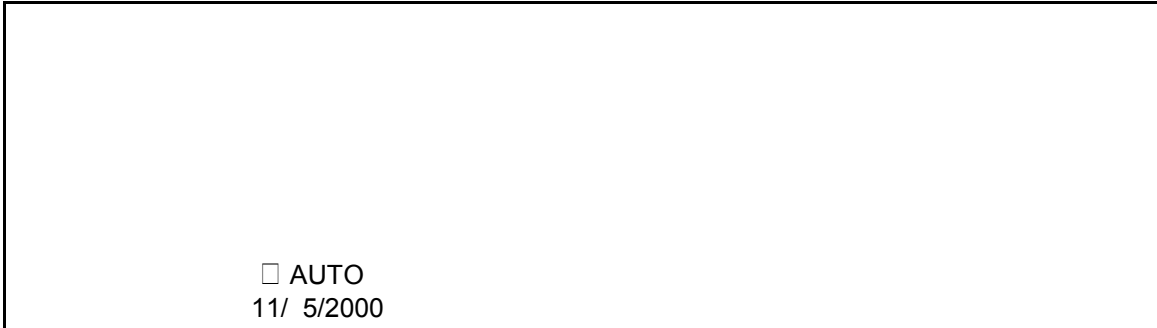

**NOTES:**

- The camcorder records the same date when;
  - the cassette is replaced.
  - you select " AUTO" and date display again.
  - the recording is less than 10 seconds long.
- If the date changes while recording continues over 10 seconds, the new date is recorded for about 10 seconds the next time you make a recording.

### TITLE and date - Automatic title and date recording

This option records the date and created title (see "TITLE RECORDING" on page 28) automatically once a day at the beginning of recording for 10 seconds.





**Date only - Date recording**

The camcorder records the date with the picture all the time.



**No display - No date recording**

The camcorder does not record the date.



**Date and time - Date and time recording**

The camcorder records the date and time with the picture all the time.



3. Press **"REC/PAUSE"**.  
Recording will start.

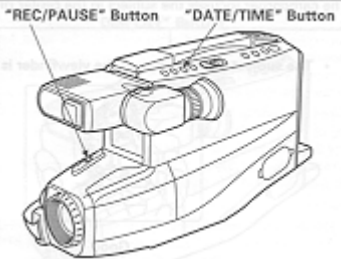

**NOTES:** When " **AUTO**" and date display is selected, the date disappears about 10 seconds after recording is started. When " **TITLE**" and date display is selected, the title and date disappear about 10 seconds after recording is started.

## AUTO FOCUS

The camcorder focuses the subject in the center of the viewfinder automatically.

- **The subject at the center of the viewfinder is in focus.**



**Good**



**No good**

### **The range of object with which auto focus can be used**

- On "**T**" side: about 2.6 feet (80 cm) from the lens surface to infinity.
- On "**W**" side: about 3/8 inch (1 cm) from the lens surface to infinity.

- The auto focus will not work under the following conditions.

1. Objects not in the center of the viewfinder.



2. Objects at far and near positions at the same time.



3. Objects lit by a spotlight or neon signs, etc.



4. Objects behind glass with water droplets or dust on it.



5. Objects with almost no difference in brightness such as a white wall.



6. Objects moving rapidly.



7. Dark objects.



## DISPLAY BUTTON

When **"DISPLAY"** is pressed, the information on the shutter speed, tape remaining, remaining battery level, etc. is displayed.



When **"DISPLAY"** is pressed so the display appears in the viewfinder, the same display appears on the screen of the connected TV/monitor receiver.

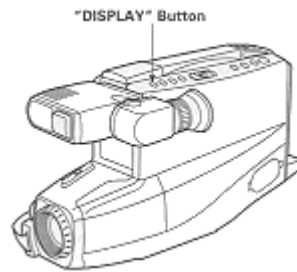

## TAPE COUNTER

When **"DISPLAY"** is pressed so the display appears in the viewfinder and recording or playback is performed, the counter indicates the amount of tape transported as a 4-digit number.

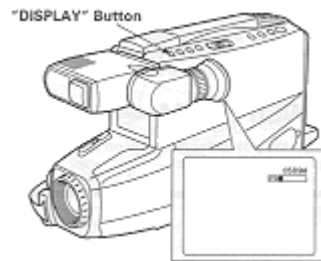

**NOTE:** Counter changes to 0000M when cassette is ejected.

## MEMORY

When the tape counter with memory indication appears in the viewfinder, a tape that is being rewound automatically stops when the counter reads approximately **"0000M"**. This is useful if there is a section of tape you want to review immediately after recording or if you want to return to the same point several times in a row.

1. Press **"DISPLAY"**. The tape counter and memory indicator **"M"** appear.
2. Start playing or recording a tape.
3. At the point you want playback to start, press **"RESET"** button to reset the counter to **"0000M"**.
4. Continue to play or record.
5. Press **"STOP/EJECT"** button to stop playback, or press **"REC/PAUSE"** button to stop recording and place **"CAM/OFF/VIDEO"** in **"VIDEO"** position.
6. Press **"REW/REVIEW"**. The tape will be rewound to the preselected point, at approximately **"0000M"** indication.

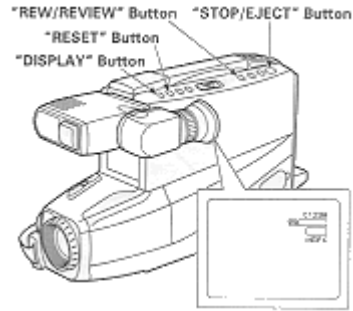

**NOTE:** The tape will also stop approximately at "0000M" during fast forward mode.

## REMAINING TAPE

When "DISPLAY" is pressed so the display appears in the viewfinder, the tape remaining display shows the remaining length of tape that can be used for recording and playback, using seven dashes. This feature is handy when recording since it lets you know how long you can record on the loaded tape. Insert a cassette in the camcorder and start recording or playback; 10 seconds later, the remaining tape will be displayed. When the cassette is ejected, the display will disappear. " -----" is displayed for 10 seconds after the tape starts to run.



### NOTES:

- When the remaining recording tape time becomes less than about five minutes, "TAPE END" flashes in the viewfinder.
- With some tapes, "TAPE END" may appear slightly earlier, but you can continue recording.

## PROGRAM AE (Auto Exposure)

Program AE automatically selects the shutter speed 1/60, 1/100, 1/120, 1/180, 1/250, 1/350, 1/500, 1/750, 1/1000, 1/1500, 1/2000 or 1/4000 second that is optimum for the brightness of the subject. The iris is also adjusted automatically in response to the shutter speed.

## POWER ZOOM

- Press the power zoom switch on the "W" side, and the picture gradually widens.



- Press the power zoom switch on the "T" side, and the picture gradually becomes telescopic. When "DISPLAY" is pressed so the display appears in the viewfinder and the power zoom switch is pressed, the zoom position is displayed in the viewfinder in 10 steps for several seconds.



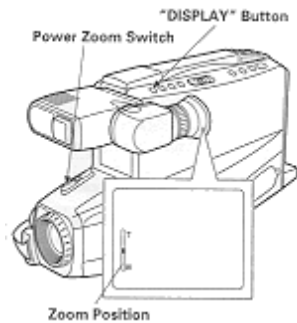

## DIGITAL ZOOM

The digital zoom increases the magnification of the power zoom by 4.5 times. You must place the subject you wish to magnify at the center of the viewfinder.



Press and hold the power zoom T control until you find the picture you want. You control the zoom with the power zoom T and W controls. When **"DISPLAY"** is pressed and the display appears in the viewfinder, **"ZOOM"** is displayed to signal to you that the camcorder is in the digital zoom area.

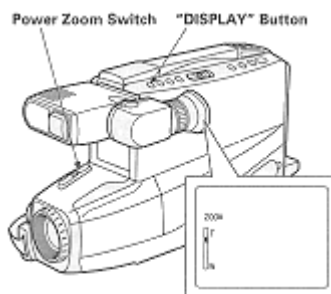

**NOTE:** When the digital zoom is used, the more the image is magnified, the rougher the picture becomes. Also even a slight shaking of the camcorder is conspicuous.

## MACRO

Allows you to shoot objects as close as 3/8 inch (1 cm) from the lens tip. Press and hold **"W"** side of power zoom switch. An object is auto focused.

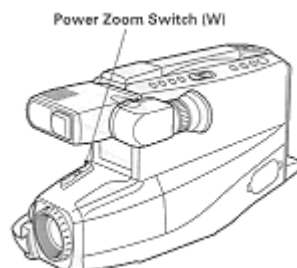

### NOTES:

- Determine the size of the object by moving the camera backward and forward.
- Be careful as the lighting tends to be insufficient when shooting in the above conditions.

## QUICK EDIT (Edit Search)

The quick edit feature allows you to search for the end of previously recorded material, or find a particular spot on your tape, to begin your editing, or recording new material. Quick edit is used while the camcorder is in the record/pause (stand-by) mode. By holding down "F.FWD", "REW/REVIEW", or "PLAY" you can visually search or play your tape. Releasing the buttons ("F.FWD", "REW/REVIEW", or "PLAY") immediately stops the tape at that position.

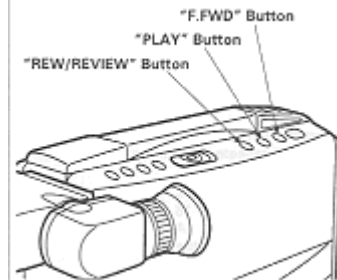

## INDEX SIGNAL RECORDING

Indexing your tapes while recording makes it easy to find desired program segments when you play back the tape in a VCR that has a compatible indexing feature called the "VHS Index Search System". See your VCR's instruction manual for index playback instructions.

"INDEX" signals are recorded when the following operations are performed.

- When the power is turned on about 4 hours after it is switched off and then recording is started.
- When the power is turned on after the date is changed to the next day with the power off and then recording is started.

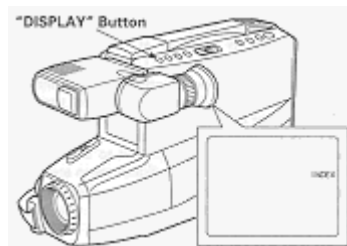

**NOTE:** When "DISPLAY" is pressed and "INDEX" is displayed in the viewfinder, an "INDEX" signal is recorded when recording is started, and when the "INDEX" signal has been recorded, "INDEX" disappears.

## TITLE RECORDING

You can easily create and record personalized titles on your videos with the camcorder's built-in titler. Once a title is stored, it can be displayed and recorded at anytime. A title contains two lines of up to 16 characters per line.

The titler contains 47 different characters for creating titles.

**NOTE:** A cassette cannot be loaded or ejected when creating a title.

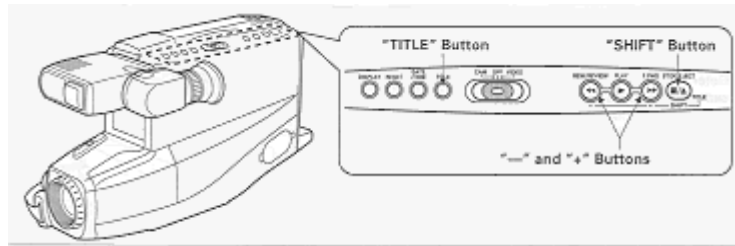

□ Creating a title

1. Attach a power source to the camcorder and slide **"CAM/OFF/VIDEO"** to either **"CAM"** or **"VIDEO"** position.
2. Press **"TITLE"**. The flashing cursor will appear in the viewfinder.

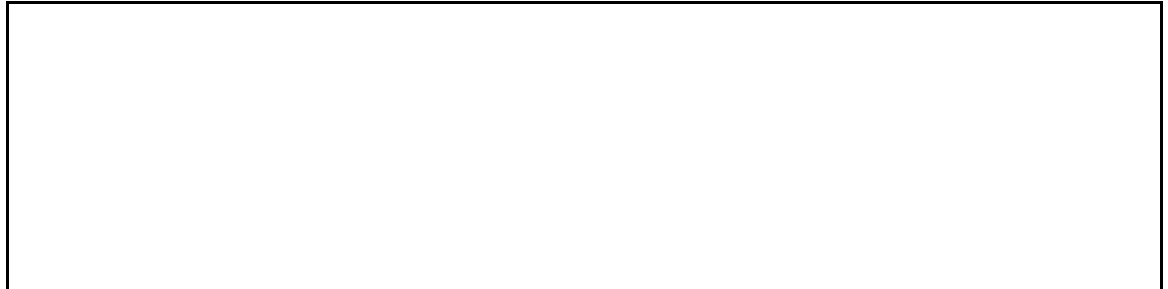

3. Press **"SHIFT"** button repeatedly to move the flashing cursor to the place you want to begin your title.
4. Select the first character for your title by pressing **"-"** or **"+"** repeatedly until the desired character appears.



**NOTE:** A title contains two lines of up to 16 characters per line. A chart showing the characters contained in the titler is located on page 29.

5. After you have selected the first character, press **"SHIFT"** to move the flashing cursor to the place you want the next character.



6. Repeat steps 4 and 5 until you have completed the title.



**NOTE:** Character may flash, however it will be recorded correctly without flashing.

7. After creating the title, press **"TITLE"** to remove the title graphics from the viewfinder. Now title graphics is stored in memory.

**NOTE:** As long as the correct current time can be displayed, the title is held in memory.

**Correcting errors during title storage**

1. Press **"SHIFT"** repeatedly until the character to be corrected will flash.
2. Press either **"-"** or **"+"** until the correct character appears.

**NOTE:** The corrected character may flash, however it will be recorded correctly without flashing.

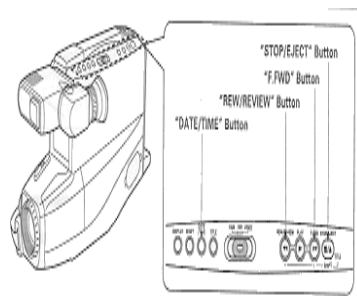

**Recording titles on a tape in the camcorder**

1. Slide **"CAM/OFF/VIDEO"** to **"VIDEO"**.
  2. Locate the position on the tape that you wish to record the title.
  3. Set **"CAM/OFF/VIDEO"** to **"CAM"**.
  4. Press **"TITLE"** to display the title graphics.
  5. Press **"REC/PAUSE"** to start the title recording.
  6. Press **"TITLE"** to remove the title graphics from the viewfinder.
- The camcorder will now record as normal.

**NOTES:**

- If you are planning to video tape an event you must prepare your titles in advance, then by pressing **"TITLE"** superimpose the title over the scene as it's being recorded. You cannot go back and record titles over existing video without erasing the previously recorded material.
- You can record the created title together with the date automatically for 10 seconds once 6 day at the beginning of recording. See **"DATE RECORDING"** on page 23 for details.

**Recording titles on another VCR while playing a tape back with the camcorder**

1. Connect the camcorder and VCR. (See page 32.)
2. Set the VCR in the recording mode and camcorder in the playback mode.
3. Press **"TITLE"** when you see the scene where you want to record the title.
4. Press **"TITLE"** to erase the display from the viewfinder.

Chart of characters available in the titler

A B C D E F G H I J K L M N O P Q R  
S T U V W X Y Z 0 1 2 3 4 5 6 7 8 9  
? ' . / , - ; < > !

## VIEWING THE PICTURE PLAYED BACK ON YOUR TV

To play back a tape recorded on your camcorder and view it on your TV receiver, you must connect the camcorder to the TV receiver using either audio/video cable (not supplied) or RF converter unit (optional). You also may play back the tape recorded by your camcorder on any other VHS video cassette recorder. The camcorder records and plays back in VHS standard speed (SP). A tape recorded in long play (LP) or extra long play (EP) cannot be played back on this camcorder.

**Example 1: If your TV has "VIDEO IN" and "AUDIO IN" jacks,**



1. Connect the audio/video cable to **"AUDIO IN"** and **"VIDEO IN"** of your TV.
2. Connect the other end of the audio/video cable to **"AUDIO"** and **"VIDEO"** of your camcorder.
3. Turn on TV and select video input.
4. Press **"STOP/EJECT"** button on the camcorder and then insert the cassette.
5. Place **"CAM/OFF/VIDEO"** in **"VIDEO"** position.
6. Press **"PLAY"**.
7. After playing press **"STOP/EJECT"**.

### Tracking adjustment

When playing prerecorded tapes or tapes recorded by the recorders other than your own, black and white streaks may appear on the TV screen. If this occurs, press **"TRACKING"** control (W or T) until the streaks disappear.

When the cassette is ejected, the tracking is reset to normal.

**Example 2: If you have a VHS VCR,**



1. Insert the recorded tape into your VCR.
2. Press **"PLAY"** of your VCR.

**NOTE:** When noise appears in the played back picture, adjust **"TRACKING"** control on the VCR so there is no noise.

**Example 3: If your TV is a regular TV,**

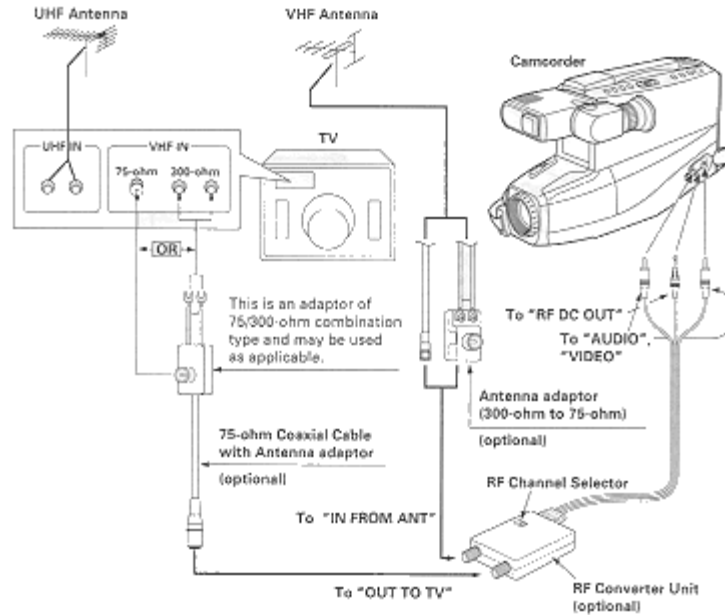

1. Disconnect the VHF antenna leads from the rear of the TV receiver.

**NOTE:** Leave the UHF antenna leads connected to the TV.

2. Connect the VHF antenna lead to **"IN FROM ANT"** on the RF converter unit. If the cable is round (75 ohm), it will connect directly to the **"IN FROM ANT"**. If it is the flat type (300-ohm), connect it to the antenna adaptor (300-ohm to 75-ohm) and slip the adaptor on to the **"IN FROM ANT"** terminal.
3. Connect the 75-ohm coaxial cable with antenna adaptor to **"OUT TO TV"** on the RF converter unit.
4. Connect the other end to the VHF antenna terminal on the TV, as illustrated.
5. Connect the connector cable from RF converter unit to **"RF DC OUT"**, **"AUDIO"** and **"VIDEO"** jacks on the camcorder.
6. Turn on the TV and set to channel 3 unless channel 3 is one of the TV stations in your area. If channel 3 is used in your area, set your TV to channel 14.
7. Set the RF channel selector on the RF converter unit to **"CH3"** or **"CH4"** to match the channel selector on your TV.
8. Perform same procedures in steps 4 through 7 of **"Example 1"**.

**NOTE:** If you want to watch a TV program with camcorder connected as illustrated, slide **"CAM/OFF/VIDEO"** of the camcorder to **"OFF"**.

## CAMCORDER TO VCR DUBBING

If you wish to exchange or copy some of your friend's favorite home recordings, the following instructions can be used to connect camcorder to VCR for this purpose.

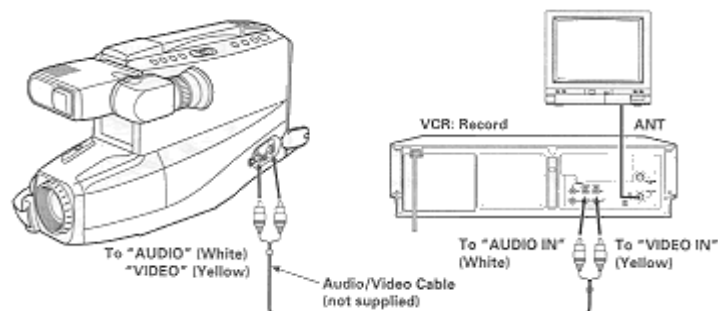

1. Connect the audio/video cable to **"AUDIO"** and **"VIDEO"** of your camcorder.

2. Connect the other ends to **"AUDIO IN"**, **"VIDEO IN"** of your VCR as shown in diagram above.
3. Play the tape on the camcorder and record it on the VCR.

**NOTE:** If you connect the **"VHF OUT TO TV"** connector of VCR to the **"TV ANT"** connector, as illustrated and set **"VCR/TV"** selector of the VCR to **"VCR"** mode, the picture being dubbed by VCR can be monitored.

## ATTACHING THE OPTIONAL TELE OR WIDE CONVERTER LENS

1. Remove the lens hood.
- Turn the lens hood counterclockwise as shown in the figure.

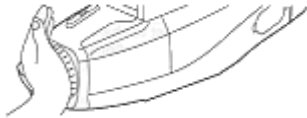

Or, attach the lens cap over the lens hood, then turn them counterclockwise to remove them.

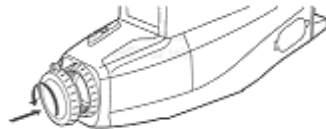

2. Remove both caps of the telephoto or wide angle lens.
3. Screw the lens into the threads on the front of camcorder lens assembly.

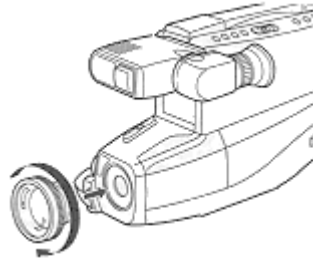

## VIEWFINDER BRIGHT CONTROL

Viewfinder brightness can be adjusted by turning the **"BRIGHT"** control. This does not affect the picture actually recorded by the camcorder.

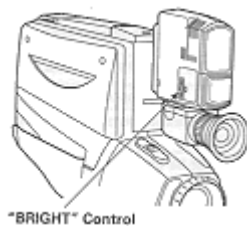

## HOW TO ATTACH THE SHOULDER STRAP

Attach the shoulder strap (provided), as illustrated.

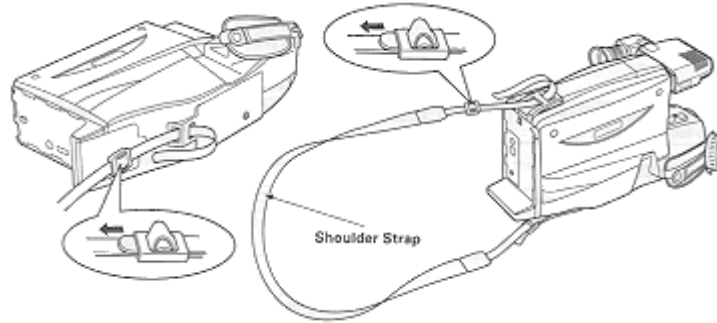

## TROUBLESHOOTING

Your camcorder is a highly sophisticated instrument. It has been carefully checked and adjusted at the factory under the most rigid quality control and inspection systems. However, should problems develop, check the following points and take necessary corrective measures.

### INSERTING OR REMOVING THE CASSETTE

Symptom	Check Point & Correction
Cassette holder cannot be opened when you press "STOP/EJECT".	* Connect the power source.
Cassette cannot be inserted into cassette compartment.	* Load cassette in direction indicated by arrow on cassette. * Cassette window must be toward outside.

### CAMERA RECORDING

Symptom	Check Point & Correction
Picture does not appear in the viewfinder.	* Remove the lens cap. * Set "CAM/OFF/VIDEO" to "CAM" position.
The camcorder can not go into the recording mode, even when "REC/PAUSE" is pressed.	* The cassette has had the erase prevention tab removed. Stick a piece of cellophane tape over the erase prevention hole or select a different cassette. * Set "CAM/OFF/VIDEO" to "CAM" position.
Picture is out of focus. Auto-focus does not operate.	Auto-focus does not operate if the wide angle or telephoto lens is attached.

### BATTERY CONDITION

Symptom	Check Point & Correction
The "  " indication in the electronic viewfinder flashes to indicate battery is discharged.	* Try another battery or charge the battery.

### NO OPERATION IS ACCEPTED

Symptom	Check Point & Correction
Power is not turned on and no button operations are accepted.	* Remove the power source, and after about one minute push the reset switch gently using a toothpick, etc. until you feel a click. Since this erases the date, time and other customer preferred features, reset them again.   (Behind the jack cover)



## PLAYBACK OF PRERECORDED CASSETTE

Symptom	Check Point & Correction
"PLAY" cannot be engaged.	* Set "CAM/OFF/VIDEO" to "VIDEO" position.
No picture appears on television screen when "PLAY" is pressed. (TV is connected to the camcorder by using RF converter unit.)	* Set the television to the camcorder channel (3 or 4) depending upon the selected channel on the RF channel select switch of RF converter unit.
Interference on playback picture.	* Adjust the tracking using "TRACKING" control (power zoom switch). * When you see the playback picture on your TV, adjust fine tuning knob on television set to obtain best picture. * The pre-recorded tape is EP or LP recording. This camcorder is for use in SP recording only.
Picture bends at the top of TV screen.	* TV receiver is of older type. It needs to be modified to work properly with camcorder * Tape is damaged. Try another cassette.
Color of your TV screen is too bright, too faint or change.	* TV set has VIR circuit. Turn it off during playback.

## CLEANING THE INSIDE OF THE ELECTRONIC VIEWFINDER

If dust or foreign matter adheres inside the viewfinder, clean it by using the following procedure.

1. Rotate and remove eye cup

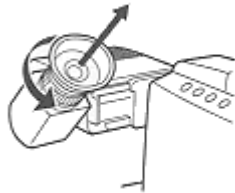

2. Clean the picture tube face and lens.  
To prevent scratching, use a soft non abrasive cloth, swab or lens cleaning paper.

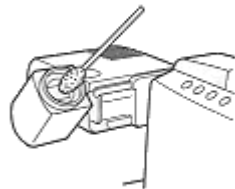

3. Align the (•) mark on the eye cup with the (-) mark on the viewfinder, and then rotate the eye cup in the direction of the arrow until a click is heard.



## HEAD CLEANING

- Picture playback may become blurred or be interrupted. This does not mean that the recorded program has been erased.
- Dirt accumulated on the head after long periods of use causes this problem. In this case, head cleaning requiring highly technical care is necessary.
- Consult your nearest dealer or VCR service center before using a head cleaning tape.



## PERIODIC MAINTENANCE

This video camcorder is a precision electromechanical device which will require periodic maintenance after a period of normal use. We expect that no maintenance other than head cleaning will be required during the warranty period by most users, unless the video camcorder is heavily used or seldom used. Normal maintenance is the responsibility of the user, although defective parts are covered during the warranty period. Consult your VCR service center to determine the recommendations for normal maintenance based on your location, use patterns and machine age.

## SPECIFICATIONS

### □ General

Power requirements	9.6V DC
Power consumption	7.5W (nominal)
Dimensions	4-1/4" (W) x 8-3/8" (H) x 13-1/8" (D) 108 (W) x 213 (H) x 334 (D) mm
Weight	4.4 lbs (2.0 kg)
Operating temperature	32°F ~ 104°F (0°C ~ 40°C)
Storage temperature	-4°F ~ 140°F (-20°C ~ 60°C)

### □ Video Recorder Section

Format	VHS
Record/playback system	Two video record/playback heads
Video signal	EIA standard NTSC color
Tape speed	33.35 mm/sec.
Video output	1.0 V p-p, 75 ohm
Fast forward/rewind time	Less than 6 minutes with T-120 cassette

### □ Camera Section

Scanning	525 lines/60 fields/30 frames
Required minimum illumination	0.3 lux
Pickup device	1/4" C.C.D.
Lens diameter	46 mm

**For U.S.A. only**

## HITACHI

Service Hotline

To locate an authorized  
HITACHI service facility in  
the continental U.S.A.

**DIAL TOLL FREE**

7 days a week, 24 hours a day

**800 HITACHI**

1-800-448-2244

**Hitachi Home Electronics (America), Inc.**

Hitachi has made every effort to assure you hours of trouble free operation from your unit. However, should you require service, a network of Hitachi Authorized Service Facilities has been established in all 50 states and Puerto Rico. Each facility will provide you with convenient and expedient assistance. Our service "Hotline" operator will direct you to the Hitachi Authorized Service Facility nearest you. Just present proof of purchase and/or delivery receipts to the Hitachi Authorized Service Facility and service will be rendered in accordance with the terms of the limited warranty as stated on your warranty card or operating guide.

---

***Should you have any questions regarding in-warranty service, operation or technical assistance, please contact:***

**Hitachi Home Electronics (America), Inc.**

1855 Dornoch Court,  
San Diego, California 92173  
Tel 619-661-3441

**ACCESSORIES ADD EXCITEMENT**

We know that once you discover how much your VM-6500A can add to your life you will want to use these accessories for even more excitement. Converter lenses and car cords are just a few of the matching accessories available to you from Hitachi. Hitachi takes you to wherever your imagination leads.

**Available Accessories**

Chart of Accessories

To place an order for any of these items call our toll free number or use the ordering form on page 49.

1-800-995-4500