

# HITACHI

## Instruction Manual



Video Camcorder

### VM-8400LA

**HITACHI HOME ELECTRONICS  
(AMERICA), INC.**

3890 Steve Reynolds Blvd., Norcross, GA 30093  
Tel. 770-279-5600

**HITACHI (HSC) CANADA INC.**

6740 Campobello Road  
Mississauga, Ontario L5N 2L8  
Tel. 905-821-4545

**HITACHI SALES CORPORATION OF HAWAII, INC.**

3219 Koapaka Street, Honolulu, HI 96819  
Tel. 808-836-3621

Thank you for choosing the  video camcorder. For maximum pleasure and convenience please read these simple instructions before operating your camcorder.

QR19391 ©Hitachi, Ltd. 1998

Printed in Japan KY-F(N)

**TABLE OF CONTENTS**

TABLE OF CONTENTS .....	2
PRECAUTIONS.....	3
FEATURES .....	4
ACCESSORIES.....	5
IMPORTANT SAFEGUARDS.....	6
IMPORTANT SAFETY INSTRUCTIONS FOR AC ADAPTER/CHARGER .....	10
ELECTRONIC VIEWFINDER (EVF).....	11
LCD MONITOR .....	13
ACTIVE SCREEN.....	15
CHECKING THE BATTERY.....	16
CHARGING THE BATTERY.....	18
INSERTING AND REMOVING CASSETTES.....	20
IDENTIFICATION AND OPERATION OF CONTROLS.....	21
MAKING A SAMPLE CAMERA RECORDING .....	22
PLAYBACK.....	25
DATE/TIME SETTING.....	27
DATE RECORDING .....	29
AUTO FOCUS .....	30
DISPLAY BUTTON.....	32
REMAINING TAPE.....	34
DIGITAL ZOOM.....	35
DIGITAL EFFECTS RECORDING .....	37
FADE IN /FADE OUT .....	40
INDEX SIGNAL RECORDING.....	42
TITLE RECORDING.....	43
AUDIO DUBBING.....	46
AUDIO AND VIDEO DUBBING .....	47
RECORDING TV PROGRAMS .....	49
VIEWING THE PICTURE PLAYED BACK ON YOUR TV .....	50
CAMCORDER TO VCR DUBBING .....	52
USING THE BUILT-IN CAMERA.....	53
ATTACHING THE OPTIONAL TELE OR WIDE CONVERTER LENS .....	55
TROUBLESHOOTING .....	56
CLEANING THE INSIDE OF THE ELECTRONIC VIEWFINDER.....	58
HEAD CLEANING .....	59
PERIODIC MAINTENANCE .....	59
SPECIFICATIONS .....	59
HOTLINE.....	61
ACCESSORIES ADD EXCITEMENT .....	62

## PRECAUTIONS

**WARNING:** TO PREVENT FIRE OR ELECTRIC SHOCK, DO NOT EXPOSE THIS APPLIANCE TO RAIN OR MOISTURE.

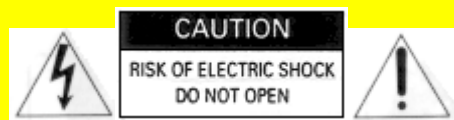

**CAUTION:** TO REDUCE RISK OF ELECTRIC SHOCK, DO NOT REMOVE COVER (OR BACK).

NO USER - SERVICEABLE PARTS INSIDE. REFER SERVICING TO QUALIFIED SERVICE PERSONNEL.



This symbol warns the user that uninsulated voltage within the unit may have sufficient magnitude to cause electric shock. Therefore, it is dangerous to make any kind of contact with any inside part of this unit.



This symbol alerts the user that important literature concerning the operation and maintenance of this unit has been included. Therefore, it should be read carefully in order to avoid any problems.

**CAUTION:**

TO PREVENT ELECTRIC SHOCK, MATCH WIDE BLADE OF PLUG TO WIDE SLOT, FULLY INSERT.

This Class B digital apparatus meets all requirements of the Canadian Interference-Causing Equipment Regulations.

**Warning:** This device complies with Part 15 of the FCC rules. Operation is subject to the following two conditions: (1) This device may not cause harmful interference, and (2) this device must accept any interference received, including interference that may cause undesired operation.

**Note:** This equipment has been tested and found to comply with the limits for a Class B digital device, pursuant to Part 15 of the FCC Rules. These limits are designed to provide reasonable protection against harmful interference in a residential installation. This equipment generates, uses, and can radiate radio frequency energy and, if not installed and used in accordance with the instructions, may cause harmful interference to radio communications. However, there is no guarantee that interference will not occur in a particular installation. If this equipment does cause harmful interference to radio or television reception, which can be determined by turning the equipment off and on, the user is encouraged to try to correct by one or more of the following measures:

- Reorient or relocate the receiving antenna.
- Increase the separation between the equipment and the receiver.
- Connect the equipment into an outlet on a circuit different from that to which the receiver is connected.
- Consult the dealer or an experienced radio/TV technician for help.

**Caution to the user:** Changes or modifications not expressly approved by the manufacturer could void the user's authority to operate the equipment.

## PRECAUTIONS

**Caution:** Avoid operating your camcorder immediately after moving it from a cold area to a warm humid area. Give the camcorder 2 to 3 hours to acclimate to the surroundings before inserting a video cassette. When moved from a cold area to a warm humid area, moisture may condense on the head drum inside the machine. This moisture could cause the tape to stick to the headwheel and damage the headwheel or tape.

See the bottom of the AC adaptor/charger. The rating and caution label is located on the bottom of the AC adaptor/charger.

**WARNING:** Many television programs and films are copyrighted. In certain circumstances, copyright law may apply to private in-home videotaping of copyrighted materials.

Any problems that occur as a result of any of the following conditions will not be covered by our warranty.

- Be careful that no water, dust, or sand enters the camcorder.
  - When you are not using the camcorder, switch off the power and attach the lens cap.
  - When you shoot at a scene which contains an extremely bright object such as the sun or a light source, a bright vertical bar may appear in the picture.
- Your camcorder is functioning properly, but the solid-state pickup device (CCD) usually causes this as an inherent characteristic. Try to avoid shooting an excessive bright object directly.

- Be sure not to leave the camcorder in a place where the temperature exceeds 140°F (60°C), or the pickup device may be damaged.

Dangerous includes:

- Inside a car with the windows closed and in direct sunshine.
- Near heating appliances.
- Do not point the electronic viewfinder to direct sunlight; it could damage the viewfinder.
- The liquid crystal display (LCD) panel is made by highly precise technology. More than 99.99% of its picture elements (pixels) are effective, but some (less than 0.01%) may not appear as coloured bright dots. This does not indicate a fault as the LCD panel stretches the limits of current technology.

## FEATURES

- 3-inch LCD with speaker
- Active screen function
- Stable pix (Electronic Image Stabilizer)
- Digital zoom up to X32
- Digital zoom up to X200 (with instant zoom)
- Digital effect
- Instant zoom
- Fade in / fade out
- Solid-state camera pickup
- **HO** High Quality picture technology
- Auto focus power zoom lens with macro feature
- Full record and playback capability with standard **VHS** cassette
- Program AE (Auto Exposure)
- Flying erase head
- Time and date

## PRECAUTIONS

- Titler
- Index signal recording
- Audio / video Input function
- Audio / video dub
- Audio dub
- Built-in automatic camera light

\* **HQ** This video camcorder with this marking incorporates **VHS** high-quality picture technology and is compatible with any video cassette recorder bearing the **VHS** mark.

With this camcorder you can view the picture being recorded or the playback picture whether on the LCD monitor or in the viewfinder. Opening or closing the LCD monitor switches the picture to appear on the LCD monitor or in the viewfinder. The following text describes the operation assuming that the viewfinder is used as a major monitor device.

## ACCESSORIES

Check to make sure you have the following components and accessories (besides the camcorder unit itself) before disposing of the packing material.

1. Lead-acid rechargeable battery
2. AC adaptor/charger
3. Shoulder strap
4. DC cord

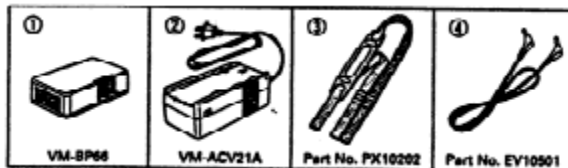

## IMPORTANT SAFEGUARDS

In addition to the careful attention devoted to quality standards in the manufacture of your video product, safety is a major factor in the design of every instrument. But, safety is your responsibility too.

This page lists important information that will help to assure your enjoyment and proper use of a Video Camcorder and accessory equipment. Please read it carefully before operating your video product and keep it in a handy place for future reference.

### INSTALLATION

**1 Read and Follow Instructions** -- All the safety and operating instructions should be read before the video product is operated. Follow all operating and use instructions.

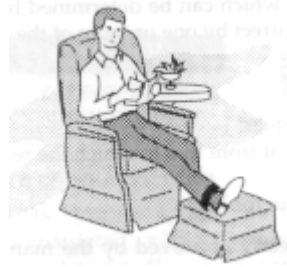

**2 Retain Instruction** -- The safety and operating instructions should be retained for future reference.

**3 Heed Warnings** -- Comply with all warnings on the video product and in the operating instructions.

**4 Polarized Plug** -- This video product is equipped with a polarized alternating-current line plug (a plug having one blade wider than the other). This plug will fit into the power outlet only one way. This is a safety feature. If you are unable to insert the plug fully into the outlet, try reversing the plug. If the plug should still fail to fit, contact your electrician to replace your obsolete outlet. To prevent electric shock do not use this polarized plug with an extension cord, receptacle or other outlet unless the blades can be fully inserted without blade exposure. If you need an extension, use a polarized cord.



**5 Power Sources** -- This video product should be operated only from the type of power source indicated on the marking label. If you are not sure of the type of power supply to your home, consult your video dealer or local power company. For video products intended to operate from battery power, or other sources, refer to the operating instructions.

**6 Overloading** -- Do not overload wall outlets and extension cords as this can result in a risk of fire or electric shock. Overloaded AC outlets and extension cords are dangerous, and so are frayed power cords, damaged or cracked wire insulation and broken plugs. They may result in shock or fire hazard. Periodically examine the cord and have it replaced by your service technician if appearance indicates damage or deteriorated insulation.



**7 Power Cord Protection** -- Power supply cords should be routed so that they are not likely to be walked on or pinched by items placed upon or against them, paying particular attention to

## IMPORTANT SAFEGUARDS

cords at plugs, convenience receptacles, and the point where they exit from the appliance.

**8 Ventilation** -- Slots and openings in the cabinet are provided for ventilation to ensure reliable operation of the video product and to protect it from overheating. These openings must not be blocked or covered. The openings should never be blocked by placing the video product on a bed, sofa, rug or other similar surface. This video product should never be placed near or over a radiator or heat register. This video product should not be placed in a built-in installation such as a bookcase or rack unless proper ventilation is provided or the video product manufacturer's instructions have been followed.

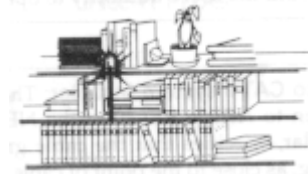

**9 Attachments** -- Do not use attachments unless recommended by the video product manufacturer as they may cause hazards.

**Caution:** Maintain electrical safety. Power-line operated equipment or accessories connected to this unit should bear the UL listing mark or CSA certification mark on the accessory itself and should not have been modified so as to defeat the safety features. This will help avoid any potential hazard from electric shock or fire. If in doubt, contact qualified service personnel.

**10 Water and Moisture** -- Do not use this video product near water -- for example, near a bath tub, wash bowl, kitchen sink, or laundry tub, in a wet basement, or near a swimming pool, and the like.

**11 Accessories** -- Do not place this video product on an unstable card, stand, tripod, bracket or table. The video product may fall, causing serious injury to a child or adult, and serious damage to the appliance. Use only with a cart, stand, tripod, bracket or table recommended by the manufacturer, or sold with the video product. Any mounting of the product should follow the manufacturer's instructions, and should use a mounting accessory recommended by the manufacturer.

**11A** An appliance and cart combination should be moved with care. Quick stops, excessive force, and uneven surfaces may cause the appliance and cart combination to overturn.



**12 Outdoor Antenna Grounding** -- If an outside antenna or cable system is connected to the video product, be sure the antenna or cable system is grounded so as to provide some protection against voltage surges and built-up static charges. Section 810 of the National Electrical Code, ANSI/NFPA No. 70, provides information with respect to proper grounding of the mast and supporting structure, grounding of the lead-in wire to an antenna discharge unit, size of grounding conductors, location of antenna-discharge unit, connection to grounding electrodes, and requirements for the grounding electrode. See example below:

### EXAMPLE OF ANTENNA GROUNDING

**13 Power Lines** -- An outside antenna system should not be located in the vicinity of overhead power lines or other electric light or power circuits, or where it can fall into such power lines or circuits. When installing an outside antenna system, extreme care should be taken to keep from touching or approaching such power lines or circuits as contact with them might be fatal. Installing an outdoor antenna can be hazardous and should be left to a

## IMPORTANT SAFEGUARDS

professional antenna installer.

### USE

**14 Cleaning** -- Unplug this video product from the wall outlet before cleaning. Do not use liquid cleaners or aerosol cleaners. Use a damp cloth for cleaning.

**15 Object and Liquid Entry** -- Never push objects of any kind into this video product through openings as they may touch dangerous voltage points or short-out parts that could result in a fire or electric shock. Never spill liquid of any kind on the video product.

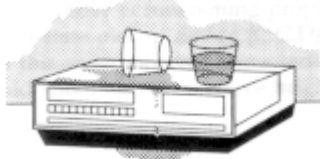

**16 Lightning** -- For added protection for this video product during a lightning storm, or when it is left unattended and unused for long periods of time, unplug it from the wall outlet and disconnect the antenna or cable-system. This will prevent damage to the video product due to lightning and power-line surges.



### SERVICE

**17 Servicing** -- Do not attempt to service this video product yourself as opening or removing covers may expose you to dangerous voltage or other hazards. Refer all servicing to qualified service personnel.

**18 Conditions Requiring Service** -- Unplug this video product from the wall outlet and refer servicing to qualified service personnel under the following conditions.

- a. When the power-supply cord or plug is damaged
- b. If liquid has been spilled or objects have fallen into the video product.
- c. If the video product has been exposed to rain or water.
- d. If the video product does not operate normally by following the operating instructions. Adjust only those controls that are covered by the operating instructions. Improper adjustment of other controls may result in damage and will often require extensive work by a qualified technician to restore the video product to its normal operation.
- e. If the video product has been dropped or the cabinet has been damaged.
- f. When the video product exhibits a distinct change in performance -- this indicates a need for service.

**19 Replacement Parts** -- When replacement parts are required, have the service technician verify that the replacements he uses have the same safety characteristics as the original parts. Use of replacements specified by the video product manufacturer can prevent fire, electric shock or other hazards

**20 Safety Check** -- Upon completion of any service or repairs to this video product, ask the service technician to perform safety checks recommended by the manufacturer to determine that the video product is in safe operating condition.

**21 Heat** -- The product should be situated away from heat sources such as radiators, heat



**IMPORTANT SAFEGUARDS**

registers, stoves, or other products (including amplifiers) that produce heat.

**IMPORTANT SAFETY INSTRUCTIONS FOR AC ADAPTER/CHARGER**

1. **Save these instructions**--This page contains important safety and operating instructions for AC Adaptor/Charger Model VM-ACV41A.
2. Before using AC Adaptor/Charger, read all instructions and cautionary markings on (1) AC Adaptor/Charger, (2) battery and (3) product using battery.
3. Also read all instructions on pages 4 and 5.

**4. Caution**--To reduce the risk of injury, charge only rechargeable battery, VM-BP64/BP65/BP66/BP67. Other types of batteries may burst causing personal injury and damage.

5. Do not expose charger to rain or snow.
6. Use of an attachment not recommended or sold by the battery charger manufacturer may result in a risk of fire, electric shock, or injury to persons.
7. To reduce the risk of damage to electric plug and cord, pull by plug rather than cord when disconnecting charger.
8. Make sure cord is located so that it will not be stepped on, tripped over, or otherwise subjected to damage or stress.
9. Do not operate charger with damaged cord or plug — replace them immediately.
10. An extension cord should not be used unless absolutely necessary. Use of improper extension cord could result in a risk of fire and electric shock. If extension cord must be used, make sure:
  - A. That the pins on plug of extension cord are the same number, size, and shape as those of plug on charger.
  - B. That extension cord is properly wired and in good electrical condition; and
  - C. That wire size should be met below:

Minimum AWG size	Length of extension cord (feet)
18	Equal to or less than 100
16	Equal to or less than 150
11. Do not operate charger if it has received a sharp blow, been dropped, or otherwise damaged in any way; take it to a qualified serviceman.
12. Do not disassemble charger; take it to a qualified serviceman when service or repair is required. Incorrect reassembly may result in a risk of electric shock or fire.
13. To reduce the risk of electric shock, unplug charger from outlet before attempting any maintenance or cleaning.

**"Note to CATV system installer:** This reminder is provided to call the CATV system installer's attention to Article 820-40 of the NEC that provides guidelines for proper grounding and, in particular, specifies that the cable ground shall be connected to the grounding system of the building, as close to the point of cable entry as practical".

## ELECTRONIC VIEWFINDER (EVF)

- Set the viewfinder to the position shown in the figure when carrying the camcorder or storing it in the carrying case.

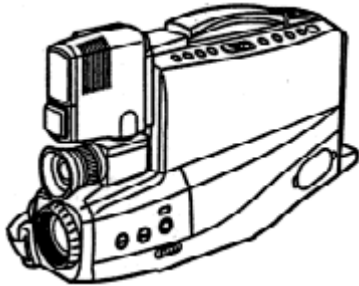

- Turn the viewfinder to the position shown below when shooting pictures.

1. Turn the viewfinder

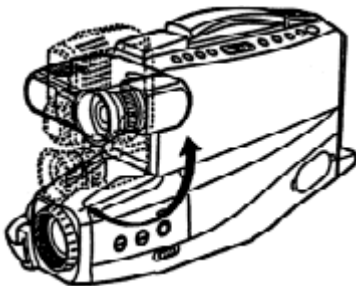

2. Turn the eyepiece.

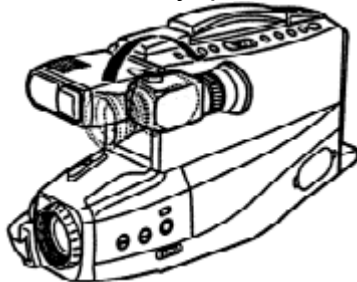

- You can adjust the position and angle of the viewfinder so you can see through it easily.

### **Cautions:**

- Do not force the viewfinder to rotate completely around. This will damage the viewfinder and/or camcorder.
- When pulling the viewfinder out or returning it to its original position, hold the viewfinder by the swivel selection. Do not hold the diopter control side.

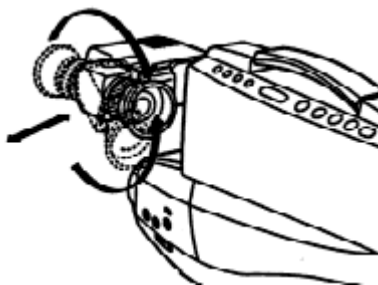

### **EYEPIECE ADJUSTMENT**

To use the electronic viewfinder without eyeglasses on, adjust the diopter control for optimum

## ELECTRONIC VIEWFINDER (EVF)

focus adjustment.

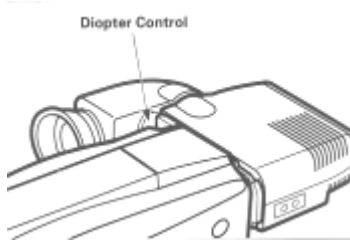

## LCD MONITOR

When using the LCD monitor during recording and playback and playback, you can adjust the brightness of its screen and the angle of the monitor.

### Opening the LCD monitor

1. Press the OPEN button to open the LCD monitor.

**NOTE:** Opening or closing the LCD monitor switches the picture to appear on the monitor or in the viewfinder.

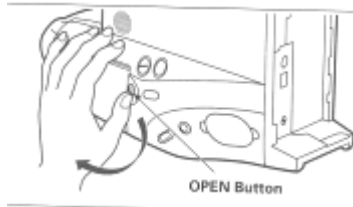

### Adjusting the brightness of the LCD screen

**NOTE:** Even when the picture on the LCD monitor is adjusted, the recorded video will not change.

1. Connect the power source. (See pages 10 and 11.) Press the red button on the CAM/OFF/VIDEO switch as you slide it to CAM or VIDEO.



2. Use the bright control on the side of the LCD monitor to adjust the brightness of the LCD screen.

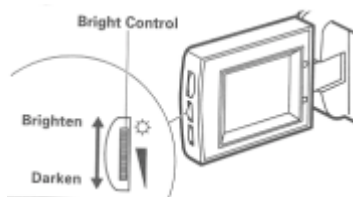

Range in which the LCD monitor can be moved.

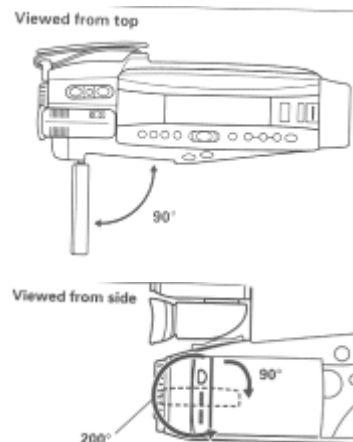

## LCD MONITOR

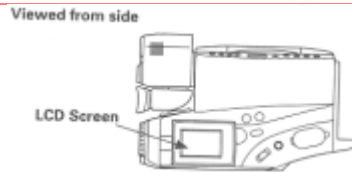

- If the LCD monitor is turned 90° so that it faces the same direction as the lens when the camera signal is being recorded during recording, recording pause, instant review, editing, A/V dubbing or A/V dubbing pause, the image on the monitor screen will become a mirror image, and the viewfinder will turn on. The on-screen display on the LCD monitor will also be as if reflected on a mirror.
- If the monitor is closed with the screen facing to the side, the mirror image will change to a normal image when the monitor has been closed about 45°; also, the viewfinder will turn off.

### **Cautions on LCD monitor screen**

- Do not touch the LCD screen with your fingers as the screen could get dirty and the picture will not be seen clearly. If the LCD screen becomes dirty, use a soft cloth to wipe off the dirt.
- If the camcorder is used in a cold place and becomes too cold, the LCD screen will be dim for a while after the power is turned on. When the temperature inside the camcorder rises, the brightness of the picture will become normal.
- Do not hold by the LCD monitor as this could cause a malfunction.
- Open the LCD monitor by 90° before changing its direction. If you were to attempt to invert its direction before opening it completely, it could cause a malfunction.
- The LCD monitor cannot be closed if it is tilted
- Close the LCD monitor after making sure it is parallel with the camcorder. If you were to close the monitor while it faces the same direction as the lens or it is diagonal, it could damage the LCD monitor.
- Do not disassemble the LCD monitor as this might cause a malfunction.
- When opening the LCD monitor, be careful that no water droplets adhere the monitor screen and that no water or dust enters the camcorder through the gap as it could cause a malfunction.

## ACTIVE SCREEN

The camcorder automatically brightens the backlight of the LCD monitor when you are recording a bright subject outdoors, so that the LCD screen is easy to see.

### NOTES:

- When you record a bright subject outdoors, the camcorder operating time will be less than when recording indoors.
- Even if you record outdoors, the LCD monitor backlight may not brighten, if you are aiming at a dark subject.

### POWER SOURCES

#### □ WHEN USING WITH THE BATTERY (Provided)

- To attach, align the mark "10," of the battery with that of the camcorder so that the battery fits into the grooves, and slide the battery downward, as illustrated.

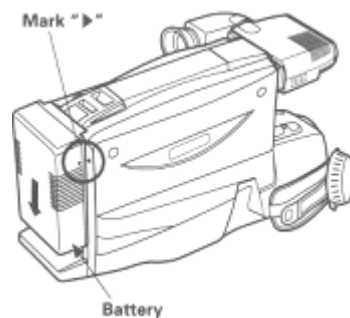

- To remove the battery:  
Push and hold "**BATTERY EJECT**" lever, then slide the battery to the upside and remove.

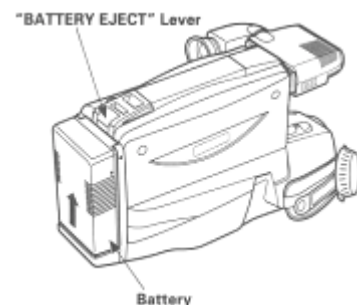

#### WHEN USING WITH THE AC ADAPTOR/CHARGER (Provided)



1. Plug the AC adaptor/charger power cord into AC electrical outlet.
2. Connect one end of the DC cord (provided) to the "**DC IN 9.6V**" jack of the camcorder. Connect the other end of the DC cord to the "**DC OUTPUT**" of the AC adaptor/charger.

**NOTES:**

- The AC adaptor/charger cannot charge the battery and operate the camcorder at the same time.
- When using the AC adaptor/charger to power the camcorder, the battery level indicator may display "▣". This indicator is used for battery operation and has no meaning when using the AC adaptor/charger to power the camcorder.

**WHEN USING WITH THE CAR BATTERY (By using optional car battery cord Hitachi VM-CC70A)**

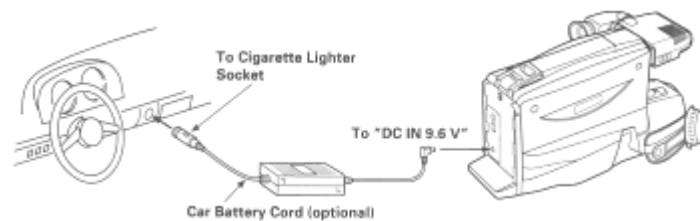

1. Connect the small plug of the car battery cord to the "DC IN 9.6V" jack of the camcorder.
2. Connect the other end of the car battery cord to the car's cigarette lighter socket.

**NOTES:**

- The car battery cord is designed to be used only with automobiles having a 12-volt negative ground system.
- To prevent fire or shock hazard or damage to your camcorder, please use only the specified car battery cord.

**CHECKING THE BATTERY**

When the "▣" indication appears in the viewfinder or LCD monitor and flashes while the camcorder is being operated with a battery (provided), it indicates that the battery charge is low. Charge it or replace it with a charged battery.

Press the "**DISPLAY**" button. The remaining battery power level will appear in the viewfinder or LCD monitor.

When the battery is fully charged, is displayed. After several minutes, the symbol will change to "▣". When the battery is very near empty, the symbol will change to "▣" and start blinking. You should find an alternative power source or recharge the battery before continuing to use your camcorder.

**NOTE:** When a battery pack is used to power the camcorder, "▣" flashes even if "**DISPLAY**" is not pressed to warn you that the battery power level is low.



ACTIVE SCREEN

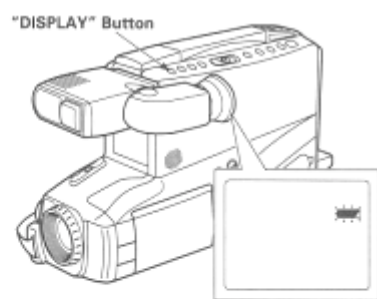

**CHARGING THE BATTERY**

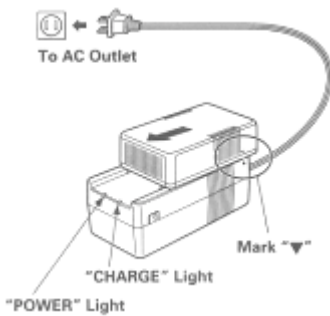

1. Plug the AC adaptor/charger power cord into AC electrical outlet.
2. Attach the battery to the AC adaptor/charger. Align the mark "▼" on the battery with that of AC adaptor/charger and push the battery flush with the AC adaptor/charger and slide it in the direction of arrow.

**NOTE:** You must remove the DC cord from the AC adaptor/charger to charge the battery. If the DC cord is connected, the **"CHARGE"** light will not light.

3. The **"CHARGE"** light will be lit while the battery is accepting a charge, and will go out when the battery is fully charged.

**Charging time**

Battery pack	VM-BP66
Charging	
Full charge	about 120 min.

**Operating time**

The camcorder operating time depends on how often you turn power on/off and use REC/PAUSE and zoom.

	Battery pack	VM-BP66
Charging	LCD monitor	
Continuous recording	OFF	about 80 min.
	ON	about 60 min.

**ATTENTION:**

The product that you have purchased contains a rechargeable battery. The battery is recyclable. At the end of its useful life under various state and local laws, it may be illegal to dispose of this battery into the municipal waste stream. Check with your local solid waste officials for details in your area for recycling options or proper disposal.



**Pb**

**NOTES:**

- The operation time depends on how often you use zoom and recording pause.
- Charge the battery after use and store it at normal room temperature.
- Recharge your battery at least once every six months. The battery is a lead-acid battery. This

## CHARGING THE BATTERY

battery tends to discharge if not used for an extended period of time. If the battery is stored for a extended length of time without being recharged, you may not be able to recharge it.

- A battery charged after being stored for a long period may not supply power for the specified time. Additional rechargings will help restore the battery's operation time.
- The battery should be charged at a temperature of 50°F - 86°F (10°C - 30°C) to prevent damage.
- Do not operate the battery at temperatures below 14°F (-10°C) or above 95°F (35°C). The battery may be damaged if operated at temperatures above 122°F (50°C). Operation time will decrease at extremely low temperatures.
- After repeated chargings and use, the operation time will gradually decrease. When operation time becomes too short to be useful, it is time to replace the battery.
- If the "**CHARGE**" light on the AC adaptor/charger starts flashing, remove the battery and then reattach it. If after several attempts the light continues to flash, this means your battery cannot take a charge and must be replaced with a new one.

The "**CHARGE**" light will not light if a hot battery is attached to the AC adaptor/charger.

Attaching an extremely hot battery to the AC adaptor/ charger is not recommended; it should be allowed to cool down before being attached.

- Do not short the battery's terminal.
- Do not attempt to disassemble or modify the battery. There are no user serviceable parts inside.
- Throwing the battery into a fire or exposing the battery to excessive heat - over 149°F (65°C) could be hazardous.
- Be sure to set "CAM/OFF/VIDEO" to the position before removing the battery.

## INSERTING AND REMOVING CASSETTES

A power source must be connected before inserting or removing cassettes. Once connected, cassettes can be inserted or removed whether the CAM/OFF/VIDEO switch is on or off.

### Inserting a cassette

1. Connect the POWER SOURCE. (See pages 10 and 11.)
2. Press "**STOP/EJECT**". The cassette door will open automatically.

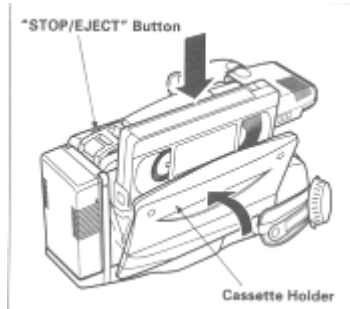

3. Insert the cassette so the transparent window is toward you and the arrow toward the cassette holder. Slide the cassette into cassette holder as far as it will go.

**NOTE:** Push in the center of the cassette all the way until it is latched by the cassette holder.

4. Press the cassette holder. The holder will latch in the operating position.

### Removing a cassette

Press "**STOP/EJECT**". The cassette door will open automatically. Remove the cassette.

**IDENTIFICATION AND OPERATION OF CONTROLS**

click for image of camcorder

click for image of camcorder

click for images of camcorder

## MAKING A SAMPLE CAMERA RECORDING

1. Connect the power source.
2. Insert the cassette.
3. Unfold the extension shoulder pad. When recording while viewing the LCD monitor, fit the extension shoulder pad on your shoulder; the LCD screen will be easy to see.



4. Open the LCD monitor if you want to view the picture being recorded on the LCD monitor. If you want to view the picture in the viewfinder, leave the monitor close.

**NOTE:** Opening or closing the LCD monitor switches the picture to appear on the LCD monitor or the viewfinder

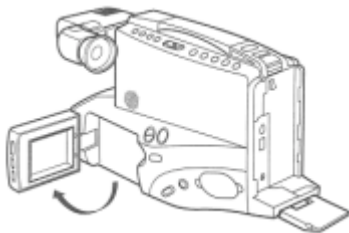

5. Press and hold the small button on "CAM/OFF/VIDEO", and then slide it to the "CAM" position. The camcorder will enter record/pause mode automatically.

### NOTES:

- If the erase prevention tab on the cassette is removed, the "TAPE" indication in the viewfinder or LCD monitor flashes for several seconds and the camcorder will not enter record/pause mode.
- See page 8 for "EYEPiece ADJUSTMENT".



6. Now, press "REC/PAUSE" to start shooting the picture. The "REC" indication appears in the viewfinder or LCD monitor and you are now recording the picture you see through the viewfinder or LCD monitor.

## MAKING A SAMPLE CAMERA RECORDING

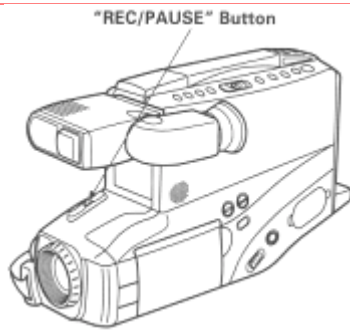

7. Press "REC/PAUSE" to stop recording. Press the button again to resume recording. The "II" indication will appear in the viewfinder or LCD monitor instead of "REC" while the camcorder is in the record/pause (stand-by) mode.

### NOTES:

- The "TAPE END" indication starts flashing in the viewfinder or LCD monitor when there is about five minutes recording time left on the cassette.
- If the record/pause mode continues for more than 5 minutes, the camcorder's power is automatically turned off. To turn on again, press "REC/PAUSE". The camcorder enters record/pause (stand-by) mode.

8. After recording, slide "CAM/OFF/VIDEO" to "OFF" position to turn off the camcorder.

9. Press "STOP/EJECT" to remove the cassette.

10. Always remove the power source from the camcorder after use.

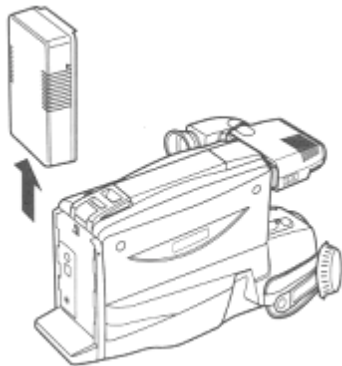

### INSTANT REVIEW

1. In record/pause (stand-by) mode, tap "REW/ REVIEW", and the last few seconds of the recorded scene is played back in the reverse direction and then played back in the forward direction.

2. When the tape reaches the end of the scene you have just recorded, the camcorder returns to the record/pause (stand-by) mode.

Recording starts again when "REC/PAUSE" is pressed again.

**NOTE:** When "REW/REVIEW" is pressed once, the camcorder enters the instant review mode, and when it is held depressed, the camcorder enters the quick edit mode.

### NOTES:

- If you have a cassette tape that has already been partially recorded on and you want to record the remaining blank section, see "QUICK EDIT" on page 34.
- You can turn the LCD monitor screen faces the same direction as the lens. When you record

## MAKING A SAMPLE CAMERA RECORDING

an image of yourself; the image displayed on the LCD monitor will be the reverse of a mirror image.

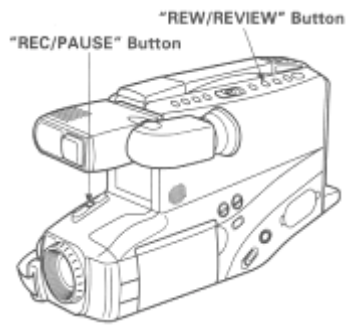



## PLAYBACK

You can view recorded pictures on the 3-inch LCD monitor immediately after recording.

- If you connect the camcorder to your TV, you can see the picture played back on your TV. Open the LCD monitor, and then adjust the angle of the monitor
  - 2. Press and hold the small button on "CAM/OFF/ VIDEO", and then slide it to the "VIDEO" position.
  - 3. Press "REW/REVIEW" to the position where you want to start playback.
  - 4. Press "PLAY" and play back the tape.
- To adjust the volume, adjust the volume control at the bottom of the camcorder.

**NOTE:** Adjust TRACKING if necessary.

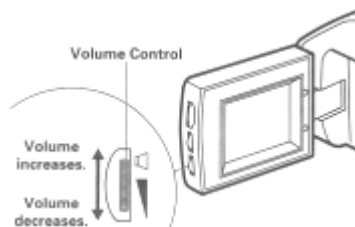

5. Press "STOP/EJECT" when you have finished.



### NOTES:

- Decrease the sound volume of the camcorder when you play back a recording by connecting the camcorder to your TV. If the volume of the camcorder is set to maximum, the played back picture may be distorted. Make sure that the volume is not set to maximum during recording as it could distort the played back picture.
- When the LCD monitor is turned on and left as it is, the monitor becomes warm, but this does not indicate a fault.
- When "CAM/OFF/VIDEO" is set to "CAM" or "VIDEO", the LCD monitor is turned on and off automatically when the LCD monitor is opened and closed.
- It is recommended that you close the LCD monitor to save the battery power when playing back a picture on a TV or recording a TV program without viewing it.
- Only the playback sound is heard. The sound being recorded is not heard.

### To play back a tape with the viewfinder

- Close the LCD monitor, then press "PLAY" to play back the tape. The picture appears in the viewfinder.

## PLAYBACK

### Using still

When "REC/PAUSE" is pressed during playback, a still picture can be seen. To start again press "REC/PAUSE" and playback will be resumed.

**NOTE:** There will be some noise (interference) in the still picture.



"REC/PAUSE" Button



### Using forward and reverse search

When you press "F.FWD" or "REW/REVIEW" during playback, the tape will be played back at a speed about 3 times faster than the normal playback speed, and you can easily locate a certain spot on the tape. Press "PLAY" to return to normal playback mode or press "STOP/EJECT" to stop tape movement.

**NOTE:** There will be some noise (interference) in the forward or reverse search pictures while visually scanning.



"F.FWD" Button

"REW/REVIEW" Button

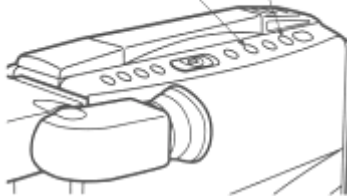

### AUTOMATIC REWIND

When the tape reaches its end during playback, it automatically rewinds to the beginning and stops.

## DATE/TIME SETTING

The date and time can be recorded on your tapes to act as a handy reference when viewing them at a later time.

Use the following procedure to set up this display for the current date and time. The time backup battery is rechargeable. Charge the backup battery every two months. Set "CAM/OFF/VIDEO" to "OFF" position and connect a charged battery or AC adaptor/charger to the camcorder for 24 hours.

Make sure that the current time is displayed correctly before you start recording.

**NOTES:** The backup battery should be charged every two months. If it is not charged periodically, it will be over-discharged and its life will be shortened.

- A cassette cannot be loaded or ejected when setting the date and time.

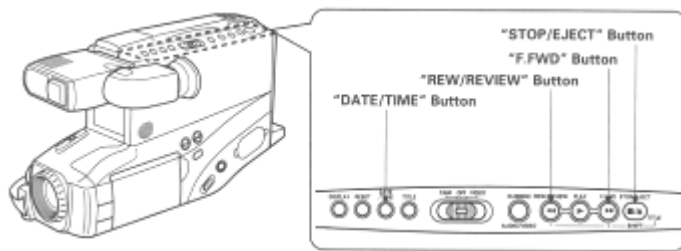

1. Press and hold the small button on "CAM/OFF/ VIDEO", and then slide it to "CAM" position.
2. Press "DATE/TIME".

Date and time appear in the viewfinder or LCD monitor and " 1 " flashes.

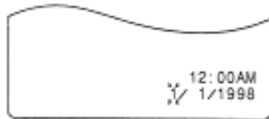

3. Press "F.FWD" to select correct month. Hold button down to advance rapidly. If you go past the month you want to set, press "REW/REVIEW". When the correct month appears, press "STOP/EJECT".



4. Press "F.FWD" to select correct date. Hold button down to advance rapidly. If you go past the date you want to set, press "REW/REVIEW". When the correct date appears, press "STOP/EJECT".

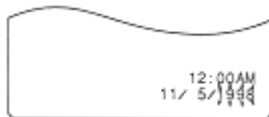

5. Press "F.FWD" or "REW/REVIEW" to select year, and then press "STOP/EJECT".

## DATE/TIME SETTING

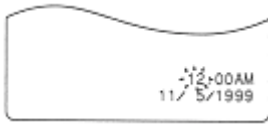

6. Press "F.FWD" or "REW/REVIEW" as many times as may be required to select correct hour, and then press "STOP/EJECT".
7. Repeat step 6 to select minute and AM/PM.

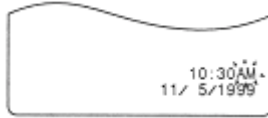

8. After setting AM or PM, press "DATE/TIME" to change the display and start the internal clock. It is recommended that you press "DATE/TIME" to match the time signal.

**NOTE:** After the date and time are set, AUTO" appears and the camcorder enters the automatic date recording mode. See "DATE RECORDING" on page 25.

- To correct date/time information after starting the date/time

1. Press and hold "DATE/TIME", and then press "STOP/EJECT". The month starts flashing.
2. Correct the incorrect digit by using "F.FWD", "REW/REVIEW" and "STOP/EJECT".

- To correct date/time information during programming

Press "STOP/EJECT" repeatedly until the digit that is incorrect flashes. Correct the incorrect digit by using "F.FWD", "REW/REVIEW" and "STOP/EJECT".

## DATE RECORDING

When the date has been set, the camcorder will enter the automatic date recording mode automatically. Specify the required date mode option before recording.

1. Press and hold the small button on "CAM/OFF/ VIDEO", and then slide it to "CAM" position.
2. Press "DATE/TIME" repeatedly to select the date display you want to record.

### AUTO and date - Automatic date recording

This option records the date automatically once a day at the beginning of recording for 10 seconds.

### NOTES:

- The camcorder records the same date when;
  - the cassette is replaced.
  - you select  AUTO and date display again.
  - the recording is less than 10 seconds long.
- If the date changes while recording continues over 10 seconds, the new date is recorded for about 10 seconds the next time you make a recording.

### TITLE and date - Automatic title and date recording

This option records the date and created title (see "TITLE RECORDING" on page 35) automatically once a day at the beginning of recording for 10 seconds.

### Date only - Date recording

The camcorder records the date with the picture all the time.

### No display - No date recording

The camcorder does not record the date.

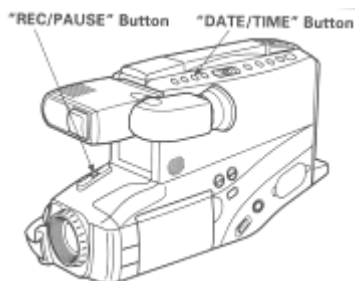

### Date and time - Date and time recording

The camcorder records the date and time with the picture all the time.



3. Press "REC/PAUSE".  
Recording will start.

### NOTES:

- When  AUTO and date display is selected, the date disappears about 10 seconds after recording is started.
- When  TITLE and date display is selected, the title and date disappear about 10 seconds after recording is started.

## AUTO FOCUS

The camcorder focuses the subject in the center of the viewfinder or LCD monitor automatically.



Good



No good

The range of object with which auto focus can be used

- On "T" side: about 2.6 feet (80 cm) from the lens surface to infinity.
- On "W" side: about 3/8 inch (1 cm) from the lens surface to infinity.

☐ The auto focus will not work under the following conditions



1. Objects not in the center of the viewfinder or LCD monitor.



2. Objects at far and near positions at the same time.



3. Objects lit by spotlight or neon signs etc.



4. Objects behind glass with water droplets or dust on it.

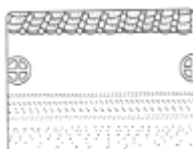

5. Objects with almost no difference in brightness such as a white wall.



6. Objects moving rapidly.



7. Dark objects.

## DISPLAY BUTTON

When "DISPLAY" is pressed, the information on the shutter speed, tape remaining, remaining battery level, etc. is displayed.

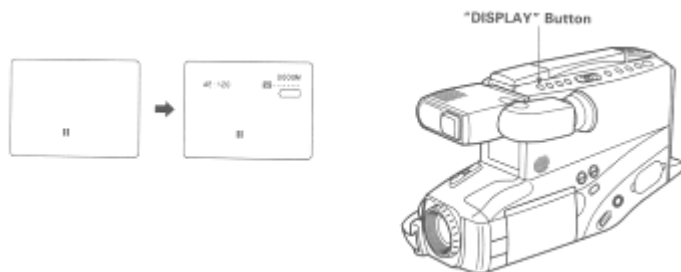

- When "DISPLAY" is pressed so the display appears in the viewfinder or LCD monitor, the same display appears on the screen of the connected TV/monitor receiver.

## TAPE COUNTER

When "DISPLAY" is pressed so the display appears in the viewfinder or LCD monitor and recording or playback is performed, the counter indicates the amount of tape transported as a 4-digit number.

**NOTE:** Counter changes to 0000M when cassette is ejected.

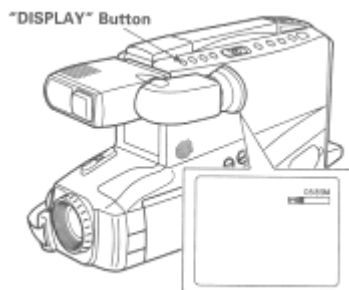

## MEMORY

When the tape counter with memory indication appears in the viewfinder or LCD monitor, a tape that is being rewound automatically stops when the counter reads approximately "0000M". This is useful if there is a section of tape you want to review immediately after recording or if you want to return to the same point several times in a row.

1. Press "DISPLAY". The tape counter and memory indicator "M" appear.
2. Start playing or recording a tape.
3. At the point you want playback to start, press "RESET" button to reset the counter to "0000M".
4. Continue to play or record.
5. Press "STOP/EJECT" button to stop playback, or press "REC/PAUSE" button to stop recording and place "CAM/OFF/VIDEO" in "VIDEO" position.
6. Press "REW/REVIEW". The tape will be rewound to the preselected point, at approximately "0000M" indication.

**NOTE:** The tape will also stop approximately at "0000M" during fast forward mode.



## DISPLAY BUTTON

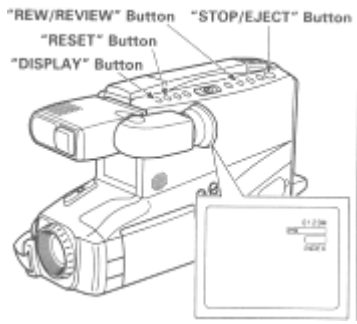

## REMAINING TAPE

When "DISPLAY" is pressed so the display appears in the viewfinder or LCD monitor, the tape remaining display shows the remaining length of tape that can be used for recording and playback, using seven dashes. This feature is handy when recording since it lets you know how long you can record on the loaded tape.



Insert a cassette in the camcorder and start recording or playback; 10 seconds later, the remaining tape will be displayed. When the cassette is ejected, the display will disappear. " [camera icon] -----" is displayed for 10 seconds after the tape starts to run.

### NOTES:

- When the remaining recording tape time becomes less than about five minutes, "TAPE END" flashes in the viewfinder or LCD monitor.
- With some tapes, "TAPE END" may appear slightly earlier, but you can continue recording.

### PROGRAM AE (Auto Exposure)

Program AE automatically selects the shutter speed 1/60, 1/100, 1/120, 1/180, 1/250, 1/350, 1/500, 1/750, 1/1000, 1/1500, 1/2000 or 1/4000 second that is optimum for the brightness of the subject. The iris is also adjusted automatically in response to the shutter speed.

### POWER ZOOM

- Press the power zoom switch on the "W" side, and the picture gradually widens.

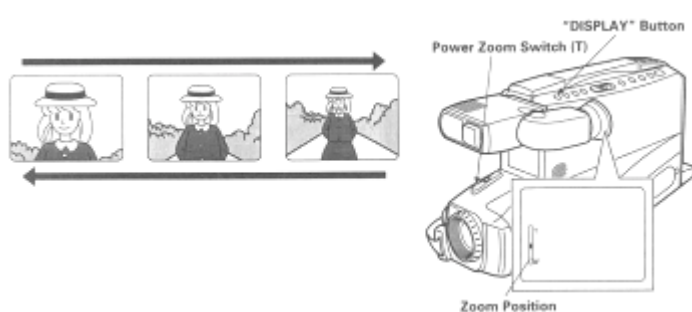

- Press the power zoom switch on the "T" side, and the picture gradually becomes telescopic.

When "DISPLAY" is pressed so the display appears in the viewfinder or LCD monitor and the power zoom switch is pressed, the zoom position is displayed in the viewfinder or LCD monitor in 10 steps for several seconds.

## DIGITAL ZOOM

The digital zoom increases the magnification of the power zoom by 2 times. You must place the subject you wish to magnify at the center of the viewfinder or LCD monitor.

Press and hold the power zoom T control until you find the picture you want. You control the zoom with the power zoom T and W controls. When "DISPLAY" is pressed and the display appears in the viewfinder or LCD monitor, "ZOOM" is displayed to signal to you that the camcorder is in the digital zoom area.

**NOTE:** When the digital zoom is used, the more the image is magnified, the rougher the picture becomes. Also even a slight shaking of the camcorder is conspicuous.

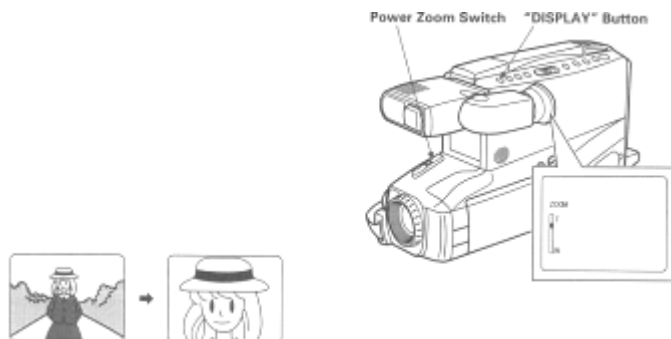

## MACRO

Allows you to shoot objects as close as 3/8 inch (1 cm) from the lens tip. Press and hold "W" side of power zoom switch. An object is auto focused.

### NOTES:

- Determine the size of the object by moving the camera backward and forward.
- Be careful as the lighting tends to be insufficient when shooting in the above conditions.

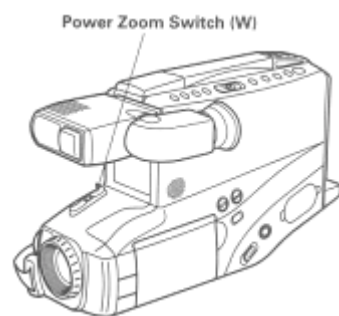

## INSTANT ZOOM

The instant zoom feature activates the digital zoom to magnify the subject 1.5 times regardless of zooming engaged by the power zoom T and W controls.

Press "INST. ZOOM" and the picture is magnified 1.5 times.

When "DISPLAY" is pressed and the display appears in the viewfinder, "I.ZOOM" is displayed to signal to you that the camcorder is in the instant zoom mode.

## DIGITAL ZOOM

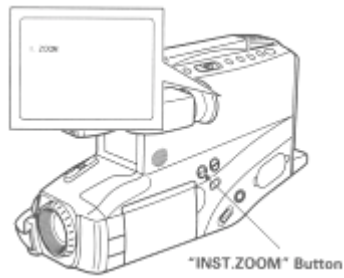

### NOTES:

- To return to the original zoom position, press "INST. ZOOM" so that "I.ZOOM" disappears from the viewfinder or LCD monitor.
- When the instant zoom is used, the more the image is magnified, the rougher the picture becomes. Also even slight shaking of the camcorder is conspicuous.

## DIGITAL EFFECTS RECORDING

The digital processor in this camcorder allows you to record pictures and add special effects; 16X9 recording mode, a negative image (negative/positive recording), 200 times digital zoom feature (with instant zoom), a symmetric image, obtained by placing a mirror at the centre of the screen (half-mirror recording), and an image in mosaic (mosaic recording).

**NOTE:** The half-mirror recording and mosaic recording functions cannot be used with digital zoom, instant zoom, stable pix or zoom fade function.



- Each time "DIGITAL EFFECT" is pressed, the recording mode is switched.

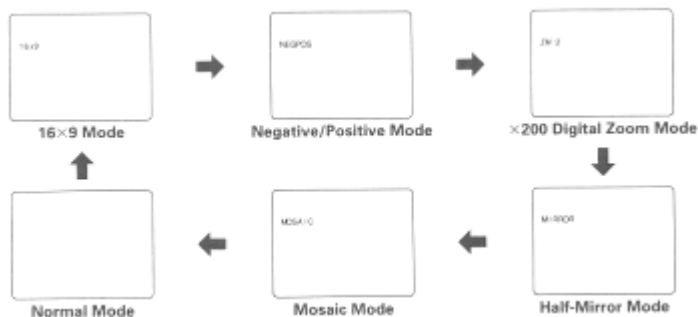

### 16x9 Mode Recording

The picture format can be switched from 4:3 (the picture format of an ordinary TV set) to 16x9.

1. Place the camcorder in record pause.
2. Press "DISPLAY" and repeatedly press "DIGITAL EFFECT" until "16x9" appears in the viewfinder or LCD monitor.

The top and bottom of the picture in the viewfinder or LCD monitor become black bars.



3. Press "REC/PAUSE" to start recording.
- To release the 16x9 mode, press "DIGITAL EFFECT" repeatedly in recording pause until normal mode is restored.

### Negative/Positive Recording

1. Place the camcorder in record pause.
2. Press "DISPLAY" and repeatedly press "DIGITAL EFFECT" until "NEGPOS" appears in the

## DIGITAL EFFECTS RECORDING

viewfinder or LCD monitor.

The image in the viewfinder or LCD monitor will become negative.

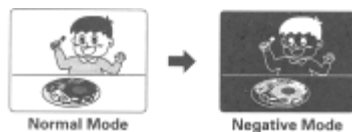

3. Press "REC/PAUSE" to start recording.

- To release the negative mode, press "DIGITAL EFFECT" repeatedly in recording pause until normal mode is restored.

### X200 Digital Zoom Recording

1. Place the camcorder in record pause.

2. Press "DISPLAY" and repeatedly press "DIGITAL EFFECT" until "ZM: 2" appears in the viewfinder or LCD monitor.

3. Press and hold the power zoom "T" control until you reach your desired magnification.

4. Press "REC/PAUSE" to start recording.

- To release the X200 digital zoom mode, press "DIGITAL EFFECT" repeatedly in recording pause until normal mode is restored.
- This function can magnify the image up to 200 times when instant zoom is used at the same time.

### Half-mirror Recording

1. Place the camcorder in record pause.

2. Press "DISPLAY" and repeatedly press "DIGITAL EFFECT" until "MIRROR" appears in the viewfinder or LCD monitor.

The image in the viewfinder or LCD monitor will change to a symmetric image on the left and right, obtained by placing a mirror at the center of the screen.



3. Press "REC/PAUSE" to start recording.

- To release the half-mirror mode, press "DIGITAL EFFECT" repeatedly in recording pause until normal mode is restored.

**NOTE:** This function cannot be used with digital zoom, instant zoom, stable pix or zoom fade function.

### Mosaic Recording

1. Place the camcorder in record pause.

2. Press "DISPLAY" and repeatedly press "DIGITAL EFFECT" until "MOSAIC" appears in the viewfinder or LCD monitor.

The image in the viewfinder or LCD monitor will be in mosaic.



### DIGITAL EFFECTS RECORDING

3. Press "REC/PAUSE" to start recording.

- To release the mosaic mode, press "DIGITAL EFFECT " repeatedly in recording pause until normal mode is restored.

**NOTE:** This function cannot be used with digital zoom, instant zoom, stable pix or zoom fade function.

## FADE IN /FADE OUT

Use the fade feature to add a professional touch to your recordings. Use "DIGITAL FADE" to select one of the four fade options.

**NOTE:** If you press the "DIGITAL EFFECT" button after setting the fade function, the fade function will be released. After setting the "DIGITAL EFFECT" mode, reset the fade function.

- White fade: Fades in from a white screen or fades out to a white screen. When "DISPLAY" is pressed and the display appears in the viewfinder or LCD monitor, "☰" appears in the upper left corner of the viewfinder or LCD monitor.

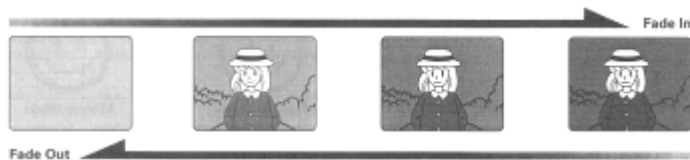

- Wipe fade: The picture opens gradually from the center of a black screen or closes into the center to a black screen. When "DISPLAY" is pressed and the display appears in the viewfinder or LCD monitor, "☰" appears in the upper left corner of the viewfinder or LCD monitor.

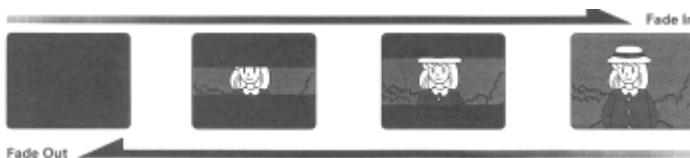

- Zoom fade: Fades in while zooming from a white screen or fades out while zooming to a white screen. When "DISPLAY" is pressed and the display appears in the viewfinder or LCD monitor, "☰" appears in the upper left corner of the viewfinder or LCD monitor.



- Black-and-white fade: Fades in from a black-and-white screen or fades out to a black-and-white screen. When "DISPLAY" is pressed and the display appears in the viewfinder or LCD monitor, "B/W" appears in the upper left corner of the viewfinder or LCD monitor.



### Fading In

1. Use "DIGITAL FADE" to select a fade option before recording.
2. Press "REC/PAUSE" to start recording; fade begins automatically.

### Fading Out

1. While recording with the camcorder use "DIGITAL FADE" to select a fade option.



## FADE IN /FADE OUT

2. Press "REC/PAUSE" to stop recording; the fade begins automatically and "REC" flashes until the fade ends.



**NOTE:** When fading out be sure to wait until the PAUSE indicator (II) is visible in the viewfinder or LCD monitor before attempting to put the camcorder into the record mode again.

## "STABLE PIX" (Electronic Image Stabilizer) FUNCTION

The stable pix function corrects slight shaking of the image being recorded and is effective in the following situations.

- While you zoom to a distant subject.
- While you approach a small subject.
- While you walk around.
- While you record from inside a moving vehicle.

1. Press "STABLE PIX". When "DISPLAY" is pressed, the display will appear in the viewfinder or LCD monitor, along with STABLE PIX icon " ".
2. Press "REC/PAUSE" to start recording. When STABLE FIX is engaged the viewfinder or LCD image shakes with a slight delay.

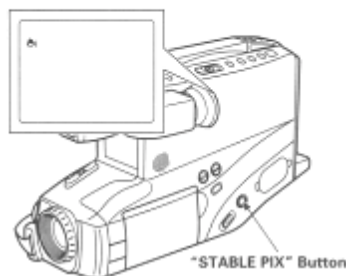

### NOTES:

- STABLE FIX may not function if you use a wide or tele converter lens.
- When the STABLE FIX function is engaged in the vicinity of the zoom range with "ZOOM" displayed in the viewfinder or LCD monitor, when moved from the wide-angle end, the image size will change, but this is normal.
- When the STABLE FIX function is engaged, the picture becomes rough.
- When the STABLE FIX function is engaged, the angle of view at the wide-angle end becomes narrower.
- It is recommended that you do not use the STABLE FIX function when using a tripod. The sensor would detect vibrations from the tripod in which case the picture would be blurred.

## INDEX SIGNAL RECORDING

Indexing your tapes while recording makes it easy to find desired program segments when you play back the tape in a VCR that has a compatible indexing feature called the "VHS Index Search System". See your VCR's instruction manual for index playback instructions.

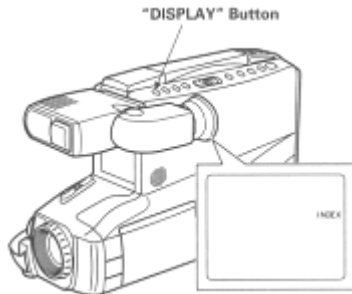

"INDEX" signals are recorded when the following operations are performed.

- When the power is turned on about 4 hours after it is switched off and then recording is started.
- When the power is turned on after the date is changed to the next day with the power off and then recording is started.

**NOTE:** When "DISPLAY" is pressed and "INDEX" is displayed in the viewfinder or LCD monitor, an "INDEX" signal is recorded when recording is started, and when the "INDEX" signal has been recorded, "INDEX" disappears.

### QUICK EDIT (Edit Search)

The quick edit feature allows you to search for the end of previously recorded material, or find a particular spot on your tape, to begin your editing, or recording new material. Quick edit is used while the camcorder is in the record/pause (stand-by) mode. By holding down "F.FWD", "REW/REVIEW", or "PLAY" you can visually search or play your tape. Releasing the buttons ("F.FWD", "REW/REVIEW", or "PLAY") immediately stops the tape at that position.

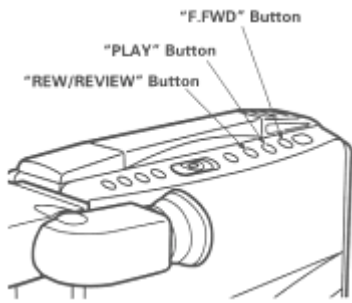

## TITLE RECORDING

You can easily create and record personalized titles on your videos with the camcorder's built-in titler. Once a title is stored, it can be displayed and recorded at anytime. A title contains two lines of up to 16 characters per line.

The titler contains 47 different characters for creating titles.

**NOTE:** A cassette cannot be loaded or ejected when creating a title.

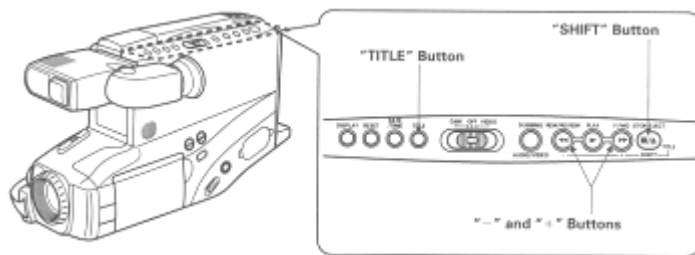

### Creating a title

1. Attach a power source to the camcorder and slide "CAM/OFF/VIDEO" to either "CAM" or "VIDEO" position.
2. Press "TITLE". The flashing cursor will appear in the viewfinder or LCD monitor.



3. Press "SHIFT" button repeatedly to move the flashing cursor to the place you want to begin your title.
4. Select the first character for your title by pressing "-" or "+" repeatedly until the desired character appears.

**NOTE:** A title contains two lines of up to 16 characters per line. A chart showing the characters contained in the titler is located on page 36.



5. After you have selected the first character, press "SHIFT" to move the flashing cursor to the place you want the next character.



6. Repeat steps 4 and 5 until you have completed the title.

## TITLE RECORDING



**NOTE:** Character may flash, however it will be recorded correctly without flashing.

7. After creating the title, press "TITLE" to remove the title graphics from the viewfinder or LCD monitor. Now title graphics is stored in memory.

**NOTE:** As long as the correct current time can be displayed, the title is held in memory.

### Correcting errors during title storage

1. Press "SHIFT" repeatedly until the character to be corrected will flash.
2. Press either "-" or "+" until the correct character appears.

**NOTE:** The corrected character may flash, however it will be recorded correctly without flashing.

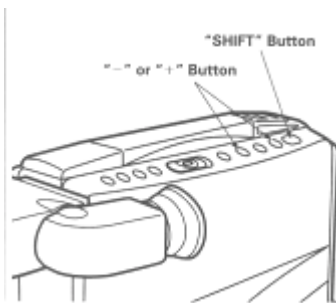

### Recording titles on a tape in the camcorder

1. Slide "CAM/OFF/VIDEO" to "VIDEO".
2. Locate the position on the tape that you wish to record the title.
3. Set "CAM/OFF/VIDEO" to "CAM".
4. Press "TITLE" to display the title graphics.
5. Press "REC/PAUSE" to start the title recording.
6. Press "TITLE" to remove the title graphics from the viewfinder or LCD monitor. The camcorder will now record as normal.

### NOTES:

- If you are planning to video tape an event you must prepare your titles in advance, then by pressing "TITLE" superimpose the title over the scene as it's being recorded. You cannot go back and record titles over existing video without erasing the previously recorded material.
- You can record the created title together with the date automatically for 10 seconds once a day at the beginning of recording. See "DATE RECORDING" on page 25 for details.

### Recording titles on another VCR while playing tape back with the camcorder

1. Connect the camcorder and VCR.  
(See page 42.)
2. Set the VCR in the recording mode and camcorder in the playback mode.
3. Press "TITLE" when you see the scene where you want to record the title.

## TITLE RECORDING

4. Press "TITLE" to erase the display from the viewfinder or LCD monitor.

Chart of characters available in the titler

A B C D E F G H I J K L M N O P Q R  
S T U V W X Y Z 0 1 2 3 4 5 6 7 8 9  
? ' . / , - ; : < > !

## AUDIO DUBBING

The audio dubbing feature lets you record new audio (sound) on a previously recorded tape without erasing the original video (picture).

When you audio dub a tape, the previous audio is erased and replaced with new sound.

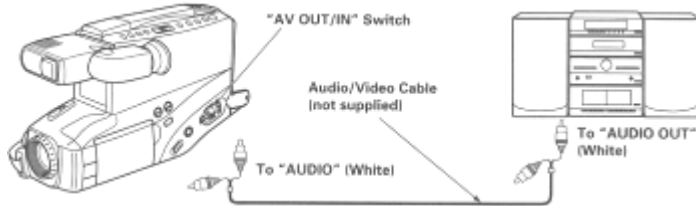

### NOTES:

- Sound from the built-in microphone and the AUDIO jack can be dubbed.
- When dubbing audio from the built-in microphone, set "" OUT/IN" to "OUT" and do not connect the "AUDIO" jack. When dubbing audio from the "AUDIO" jack, set "" OUT/IN" to "IN".

1. Insert a recorded tape.

Be sure that the record safety tab is not missing.

2. Place "CAM/OFF/VIDEO" to "VIDEO" position.

3. Play the tape and press "REC/PAUSE" where you want to dub audio.

- The camcorder enters the still play mode.

4. Press "DUBBING AUDIO/VIDEO" and "PLAY" at the same time.

- "A.DUB II" appears in the viewfinder or LCD monitor.

**NOTE:** If "DUBBING AUDIO/VIDEO" and "PLAY" are pressed twice, audio and video dubbing will start. In this case, press "STOP/EJECT" to release the dubbing mode.

5. Press "REC/PAUSE" to start audio dubbing.

6. Press "STOP/EJECT" to stop audio dubbing.

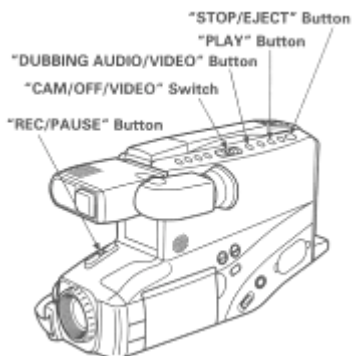

**NOTE:** If "DISPLAY" is pressed so the display appears in the viewfinder or LCD monitor, the tape stops automatically at the reading of "0000M" and audio dubbing stops.

## AUDIO AND VIDEO DUBBING

The audio and video dubbing feature lets you record new audio (sound) and video (pictures) simultaneously on a previously recorded tape.

When you audio and video dub a tape, the previous audio and video are erased and replaced with the new sound and pictures. The replacement audio and video can be the sound and picture taken by the camera or from a video source connected to "AUDIO" and "VIDEO" on the camcorder.

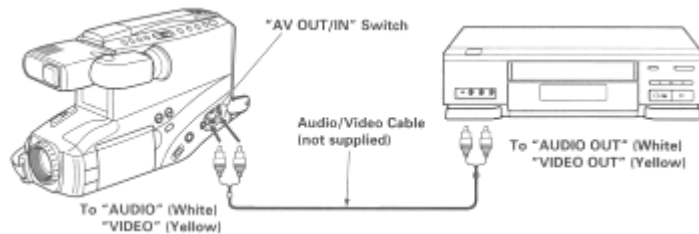

**NOTE:** When dubbing the sound and picture from a video source, set "AV OUT/IN" to the "IN" position. When dubbing the sound and picture from the camera, set "AV OUT/IN" to "OUT" and do not connect "AUDIO" and "VIDEO" jacks.

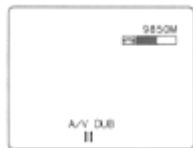

1. Insert a recorded tape.  
Be sure that the record safety tab is not missing.
2. Place "CAM/OFF/VIDEO" in "VIDEO" position.
3. Press "DISPLAY" to display the tape counter.
4. Press "PLAY" and then "REW/REVIEW" or "F.FWD" to search to the approximate position of the tape on which you want to dub sound and picture.
5. Press "PLAY" again to search the exact position where you wish to stop dubbing and then press "REC/PAUSE" at the exact position.
6. Press "RESET" to set the tape counter reading to "0000M".
7. Press "REW/REVIEW" to rewind the tape to the approximate position from which you want to start dubbing.
8. Press "PLAY", and when the exact position to start dubbing is reached, press "REC/PAUSE".
9. Press "DUBBING AUDIO/VIDEO" and "PLAY" simultaneously twice. "A/V DUB II" is displayed in the viewfinder or LCD monitor, and at the same time the picture to be dubbed appears.

## AUDIO AND VIDEO DUBBING

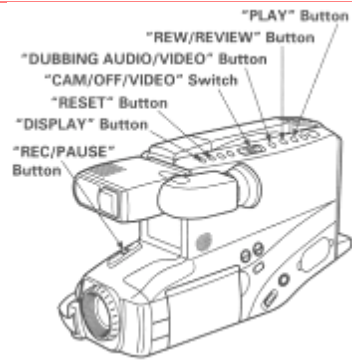

10. Press the "REC/PAUSE".  
Dubbing will start and will stop when the counter reads "0000M"



## RECORDING TV PROGRAMS

If your TV or VCR has video/audio out jacks, you can record the TV program with camcorder.

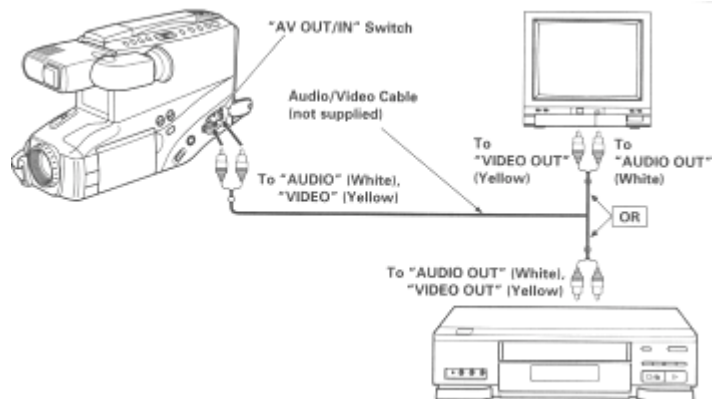

1. Connect the audio/video cable (not supplied) to "AUDIO OUT" and "VIDEO OUT" of your TV or VCR.
2. Connect the other end to "AUDIO" and "VIDEO" of camcorder.
3. Insert the cassette.

**NOTE:** Power source must be connected to the camcorder.

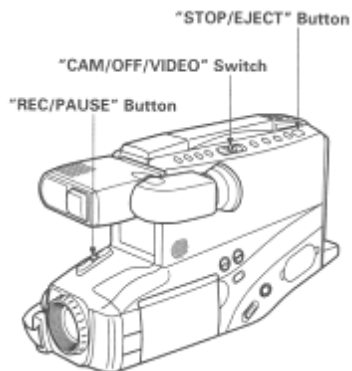

4. Set "AV OUT/IN" to "IN" position.
5. Press and hold the small button on "CAM/OFF/ VIDEO", and then slide it to "CAM" position.
6. Turn on your TV or VCR and tune it to the channel you wish to record.
7. Press "REC/PAUSE" to start recording. You are now recording the TV program.
8. Press "REC/PAUSE" to stop recording.
9. After recording, place "CAM/OFF/VIDEO" in "OFF" and then press "STOP/EJECT" to remove the cassette.

## VIEWING THE PICTURE PLAYED BACK ON YOUR TV

To play back a tape recorded on your camcorder and view it on your TV receiver, you must connect the camcorder to the TV receiver using either audio/video cable (not supplied) or RF converter unit (optional).

You also may play back the tape recorded by your camcorder on any other VHS video cassette recorder. The camcorder records and plays back in VHS standard speed (SP). A tape recorded in long play (LP) or extra long play (EP) cannot be played back on this camcorder.

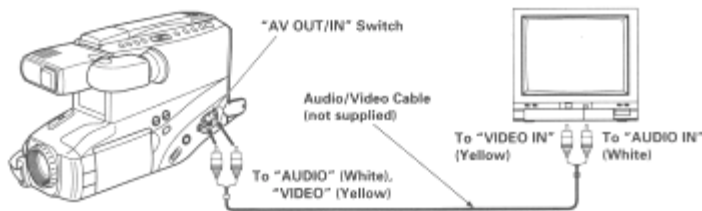
**Example 1: If your TV has "VIDEO IN" and "AUDIO IN" jacks,**

**NOTE:** Make sure that the "AV OUT/IN" is in the "OUT" position.

1. Connect the audio/video cable to "AUDIO IN" and "VIDEO IN" of your TV.
2. Connect the other end of the audio/video cable to "AUDIO" and "VIDEO" of your camcorder.
3. Turn on TV.
4. Press "STOP/EJECT" button on the camcorder and then insert the cassette.
5. Place "CAM/OFF/VIDEO" in "VIDEO" position.
6. Press "PLAY".
7. After playing press "STOP/EJECT".

**Tracking adjustment**

When playing prerecorded tapes or tapes recorded by the recorders other than your own, black and white streaks may appear on the TV screen. If this occurs, press "TRACKING" control (W or T) until the streaks disappear.

When the cassette is ejected, the tracking is reset to normal.

**Example 2: If you have a VHS VCR,**

1. Insert the recorded tape into your VCR.
2. Press "PLAY" of your VCR.

**NOTE:** When noise appears in the played back picture, adjust "TRACKING" control on the VCR so there is no noise.

**Example 3: If your TV is a regular TV,**  
click for image of diagram

**NOTE:** Make sure that the "AV OUT/IN" is in the "OUT" position.

## VIEWING THE PICTURE PLAYED BACK ON YOUR TV

1. Disconnect the VHF antenna leads from the rear of the TV receiver.

**NOTE:** Leave the UHF antenna leads connected to the TV.

2. Connect the VHF antenna lead to "IN FROM ANT" on the RF converter unit. If the cable is round (75ohm), it will connect directly to the "IN FROM ANT". If it is the flat type (300-ohm), connect it to the antenna adaptor (300-ohm to75-ohm) and slip the adaptor on to the "IN FROM ANT" terminal.
3. Connect the 75-ohm coaxial cable with antenna adaptor to "OUT TO TV" on the RF converter unit.
4. Connect the other end to the VHF antenna terminal on the TV, as illustrated.
5. Connect the connector cable from FIF converter unit to "RF DC OUT", "AUDIO" and "VIDEO"jacks on the camcorder.
6. Turn on the TV and set to channel 3 unless channel 3 is one of the TV stations in your area. If channel 3 is used in your area, set your TV to channel 4.
7. Set the RF channel selector on the RF converter unit to "CH3" or "CH4" to match the channel selector on your TV.
8. Perform same procedures in steps 4 through 7 of "Example 1".

**NOTE:** If you want to watch a TV program, with camcorder connected as illustrated, slide "CAM/OFF/VIDEO" of the camcorder to "OFF".

## CAMCORDER TO VCR DUBBING

If you wish to exchange or copy some of your friend's favorite home recordings, the following instructions can be used to connect camcorder to VCR for this purpose.

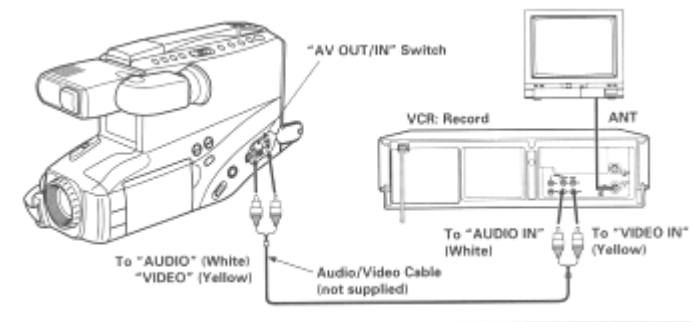

**NOTE:** Make sure that the "AV OUT/IN" is in the "OUT" position.

1. Connect the audio/video cable to "AUDIO" and "VIDEO" of your camcorder.
2. Connect the other ends to "AUDIO IN", "VIDEO IN" of your VCR as shown in diagram above.
3. Play the tape on the camcorder and record it on the VCR.

**NOTE:** If you connect the "VHF OUT TO TV" connector of VCR to the "TV ANT" connector, as illustrated and set "VCR/TV" selector of the VCR to "VCR" mode, the picture being dubbed by VCR can be monitored.

### FLYING ERASE HEAD

A rotating erase head which eliminates glitches and rainbow noise that occurs at the joints between recorded segments.

## USING THE BUILT-IN CAMERA

Use the built-in camera light if you wish to shoot objects in dark places.

When "LIGHT" is set to "AUTO", the camera light turns on automatically when the camcorder is pointed at objects in a dark place and turns off when it is pointed at objects in a bright place.

**CAUTION:** The power consumption of the built-in camera light is about a half that of the camcorder. Therefore, if the camera light is turned on when a fully charged battery pack is attached, the operating time of the battery falls to about a half.

1. Make sure that a fully charged battery pack or AC adaptor/charger is attached.
2. Set "CAM/OFF/VIDEO" to "CAM" and then set "LIGHT" to "AUTO" when required.

**NOTE:** When "LIGHT" is set to "ON", the camera light will turn on whenever you make a recording.

**CAUTIONS:**

- Turn the camera light on only when you need it, otherwise the operating time of the battery pack is shortened due to the power consumption of the camera light.
- When "LIGHT" is set to "AUTO", the camera light does not turn on unless a cassette is loaded.

**CAUTION:** Do not hold the unit by the built-in camera light when carrying as this could cause a malfunction.



3. After use, set "LIGHT" to "OFF" or set "CAM/OFF/VIDEO" of the camcorder to "OFF" position.

**CAUTION:**

- During operation and/or after use of the camera light, the front surface and lamp of the camera light will be very hot. To avoid burns or hair damage, do not touch them with your hand.
- When the camera light is on, do not allow water to drop on the light.
- When the camera light is on, avoid subjecting the camera light to impacts or sharp vibrations.
- Do not allow the cooling vents to become blocked. Also, do not cover the camera light with paper or other objects, since the air flow will be interrupted, resulting in possible overheating hazard.
- Never use the camera light in the vicinity of explosive or highly inflammable materials.
- After using the camera light, cool the camera light section sufficiently before storing the camcorder in the case.

## USING THE BUILT-IN CAMERA

- Replace only with the specified lamp (optional) to reduce the risk of fire.

### To replace the lamp of camera light

- To remove the front case, press and hold the tab, then remove the front case.

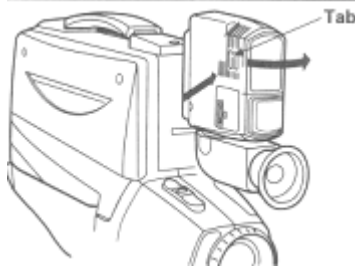

- To replace the front case, pass the lamp through the hole of the reflection plate then attach the upper hooks to the camera light, and then attach the lower hook to the camera light.

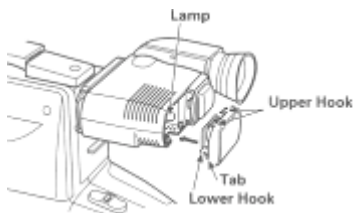

### NOTES:

- Do not touch the lamp directly with your fingers. It may shorten its service life.
- When the lamp is replaced, or when the front case of the camera light is removed, make sure the front case is attached to the camera light properly.
- Consult your nearest service center to replace the lamp.

## ATTACHING THE OPTIONAL TELE OR WIDE CONVERTER LENS

1. Remove the lens hood.  
Turn the lens hood counterclockwise as shown in the figure.

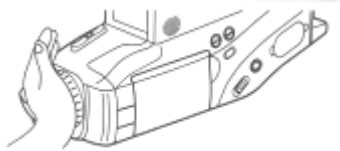

Or, attach the lens cap over the lens hood, then turn them counterclockwise to remove them.

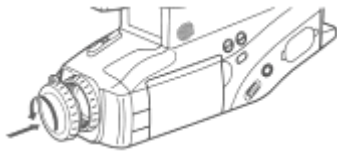

2. Remove both caps of the telephoto or wide angle lens.
3. Screw the lens into the threads on the front of camcorder lens assembly.

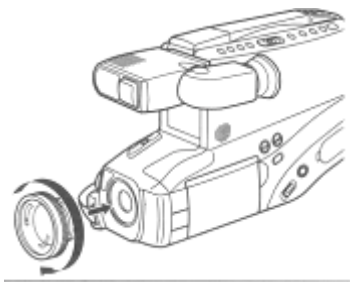

## HOW TO ATTACH THE SHOULDER STRAP

Attach the shoulder strap (provided), as illustrated.

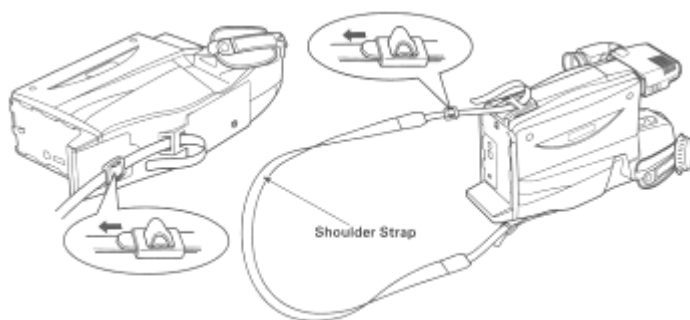

**TROUBLESHOOTING**

Your camcorder is a highly sophisticated instrument. It has been carefully checked and adjusted at the factory under the most rigid quality control and inspection systems. However, should problems develop, check the following points and take necessary corrective measures.

**INSERTING OR REMOVING THE CASSETTE**

<b>Symptom</b>	<b>Check Point &amp; Correction</b>
Cassette holder cannot be opened when you press "STOP/EJECT".	Connect the power source.
Cassette cannot be inserted into cassette compartment.	Load cassette in the direction indicated by arrow on cassette.
	Cassette window must be toward outside.

**CAMERA RECORDING**

<b>Symptom</b>	<b>Check Point &amp; Correction</b>
Picture does not appear in the viewfinder.	Remove the lens cap.
	Set "CAM/OFF/VIDEO" to "CAM"
The camcorder can not go into the recording mode, even when "REC/PAUSE" button is pressed.	The cassette has had the erase prevention tab removed. Stick a piece of cellophane tape over the erase prevention hole or select a different cassette.
Picture is out of focus. Auto-focus does not operate.	Auto-focus does not operate if the wide angle or telephoto lens is attached.

**RECORDING TV PROGRAMS OFF THE AIR**

<b>Symptom</b>	<b>Check Point &amp; Correction</b>
The camcorder can not go into the recording mode even when "REC/PAUSE" button is pressed.	The cassette has had the erase prevention tab removed. Stick a piece of cellophane tape over the erase prevention hole or select a different cassette.
	Set "CAM/OFF/VIDEO" to "CAM" position.
	Connect the camcorder and TV (or VCR).
	Set "AV OUT/IN" to "IN" position.

**BATTERY CONDITION**



**TROUBLESHOOTING**

<b>Symptom</b>	<b>Check Point &amp; Correction</b>
The "■" indication in the electronic viewfinder flashes to indicate battery is discharged.	Try another battery or charge the battery.

**NO OPERATION IS ACCEPTED**

<b>Symptom</b>	<b>Check Point &amp; Correction</b>
Power is not turned on and no button operations are accepted.	Remove the power source and after about one minute, push the reset switch gently using a toothpick, etc. until you feel a click. Since this erases the date, time and other customer preferred features, reset them again.

**PLAYBACK OF PRE-RECORDED CASSETTE**

<b>Symptom</b>	<b>Check Point &amp; Correction</b>
"PLAY" cannot be engaged.	Set "CAM/OFF/VIDEO" to VIDEO position.
No picture appears on television screen when "PLAY" is pressed.	Set the television to the camcorder channel (3 or 4) depending upon the selected channel on the RF channel select switch of RF converter unit.
	Set "AV IN/OUT" switch to "OUT" position.
Interference on playback picture.	Adjust the tracking using "TRACKING" control (power zoom switch)>
	When you see the playback picture on your TV, adjust fine tuning knob on television set to obtain best picture.
	The pre-recorded tape is EP or LP recording. This camcorder is for use in SP recording only.
Picture bends at the top of the TV screen.	TV receiver is of older type it needs to be modified to work properly with camcorder.
	Tape is damaged. Try another cassette.
Color of your TV screen is too bright, too faint or change.	TV set has VIR circuit. Turn off during playback.

**CLEANING THE INSIDE OF THE ELECTRONIC VIEWFINDER**

If dust or foreign matter adheres inside the viewfinder, clean it by using the following procedure.

1. Push the tab and hold it, then open the cover.

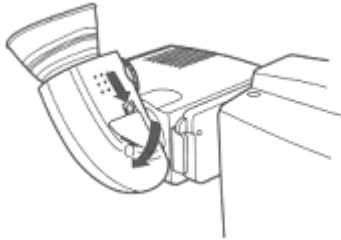

2. Clean the picture tube face and lens. To prevent scratching, use a soft non abrasive cloth, swab or lens cleaning paper.

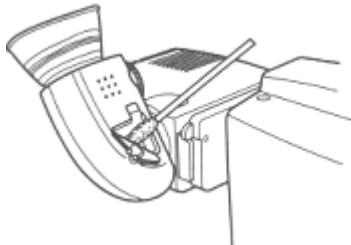

3. Close the cover.

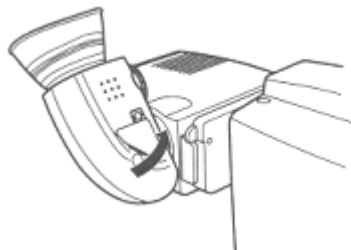

## HEAD CLEANING

- Picture playback may become blurred or be interrupted. This does not mean that the recorded program has been erased.
- Dirt accumulated on the head after long periods of use causes this problem. In this case, head cleaning requiring highly technical care is necessary.
- Consult your nearest dealer or VCR service center before using a head cleaning tape.



## PERIODIC MAINTENANCE

The video camcorder is a precision electromechanical device which will require periodic maintenance after a period of normal use. We expect that no maintenance other than head cleaning will be required during the warranty period by most users, unless the video camcorder is heavily used or seldom used. Normal maintenance is the responsibility of the user, although defective parts are covered during the warranty period. Consult your VCR service center to determine recommendations for normal maintenance based upon your location, use patterns and machine age.

## SPECIFICATIONS

### General

Power requirements	9.6V DC
Power consumption	9W (nominal)
Dimensions:	4-3/4"(W) x 8-3/8" (H) x 13-1/8" (D) 121(W) x 213(H) x 334(D) mm
Weight	4.7 lbs (2.15 kg)
Operating temp.	32°F ~ 104°F (0°C ~ 40°C)
Storage temp.	-4°F ~ 140°F (-20°C ~ 60°C)

### Video Recorder Section

Format	VHS
Record/playback system	Two video record/playback heads plus a flying erase head
Video signal	EIA standard NTSC color
Tape speed	33.35 mm/sec.
Video input	1.0 VP-p, 75 ohm
Video output	1.0 Vp-p, 75 ohm
Audio input	-7.8 dBs (316 m Vrms), more than 47 kohm
Audio output	-7.8 dBs (316 m Vrms), less than 1 kohm
Fast forward/rewind time	Less than 6 minutes with T-120 cassette

### Camera Section

Scanning	525 lines/ 60 fields/ 30 frames
Required minimum illumination	.8 lux

**HEAD CLEANING**

Pickup device	1/4" C.C.D.
Lens diameter	46 mm

**HOTLINE**

For U.S.A. only

**HITACHI**

Service Hotline

To locate an authorized  
HITACHI service facility in  
the continental U.S.A.

**DIAL TOLL FREE**

7 days a week, 24 hours a day

800 HITACHI

1-800-448-2244

**Hitachi Home Electronics (America), Inc.**

Hitachi has made every effort to assure you hours of trouble free operation from your unit. However, should you require service, a network of Hitachi Authorized Service Facilities has been established in all 50 states and Puerto Rico. Each facility will provide you with convenient and expedient assistance. Our service "Hotline" operator will direct you to the Hitachi Authorized Service Facility nearest you. Just present proof of purchase and/or delivery receipts to the Hitachi Authorized Service Facility and service will be rendered in accordance with the terms of the limited warranty as stated on your warranty card or operating guide.

---

***Should you have any questions regarding in-warranty service, operation or technical assistance, please contact:***

**Hitachi Home Electronics (America), Inc.**

3890 Steve Reynolds Blvd  
Norcross, GA 30093  
Tel 770-279-5600

**Hitachi Sales Corporation of Hawaii**

3219 Koapaka St./Honolulu, HI 96819  
Tel 808-836-3621

**ACCESSORIES ADD EXCITEMENT**

We know that once you discover how much your VM-8400LA can add to your life you will want to use these accessories for even more excitement. Converter lenses and car cords are just a few of the matching accessories available to you from Hitachi. Hitachi takes you to wherever your imagination leads.

**Available Accessories**

Chart of Accessories

To place an order for any of these items call our toll free number..

1-800-995-4500

**HOW TO ORDER** USA only

**BY PHONE**

To place your order by phone, have your VISA, MASTER CARD, or DISCOVER card ready and call the toll-free number (8:00 AM – 6:00 PM East Coast Time – workdays).

**1-800-995-4500**

Please allow two to three weeks for delivery. If there is a current back order status on the model(s) you ordered, we will notify you.

Thank you for allowing us (Hitachi and HiTRON) to be of service to you ... our valued customer!

**FOR AUTHORIZED HITACHI SERVICE FACILITY IN CANADA**

Please consult the following telephone number:

Montreal (514) 956-9882

Toronto (905) 821-4545

Vancouver (604) 214-0777

**U.S.A. only**

HiTRON Order Form for VM-8400LA

<b>Description</b>	<b>Part No.</b>	<b>Price</b>
TRIPOD	SVA 50	99.95
REPLACEMENT BATTERY	VM-BP66	49.95
REPLACEMENT BATTERY	VM-BP67	69.95
CARRYING CASE	CB8400	39.95
CAR CORD	VM-CC70A	79.95
CONVERSION LENS SET	VM-CL12TW	139.95
FILTER KIT	VM-FL46K	39.95

ACCESSORIES ADD EXCITEMENT

FILTER KIT	VM-FL60K	99.95
RF CONVERTER	VM-RF80A	39.95
SHOULDER STRAP	VM-SS70	14.95

---