

HITACHI
Instruction Manual

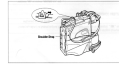

Video Camera/Recorder
VM-3700A



Hitachi Home Electronics (America), Inc.
INC.

3890 Steve Reynolds Blvd., Norcross, GA 30093
Pointe Claire,
Tel. 404-279-5600

HITACHI SALES CORPORATION OF HAWAII, INC.

3219 Koapaka Street, Honolulu, HI 96819
Tel. 808-836-3621
P QR10511 ©Hitachi, Ltd. 1994
KS-M(N)

HITACHI (HSC) CANADA

3300 Trans Canada Hwy.,
Quebec, H9R1B1, CANADA
Tel. 514-697-9150

Printed in Japan

TABLE OF CONTENTS

TABLE OF CONTENTS 2

WARNINGS 4

PRECAUTIONS 6

 PRECAUTIONS 6

 FEATURES 7

 ACCESSORIES 7

IMPORTANT SAFEGUARDS 8

IMPORTANT SAFETY INSTRUCTIONS FOR AC ADAPTER/CHARGER 12

ELECTRONIC VIEWFINDER 14

POWER SOURCES 16

 WHEN USING WITH THE BATTERY (Provided) 16

 WHEN USING WITH THE AC ADAPTER/CHARGER (Provided) 16

 WHEN USING WITH THE CAR BATTERY (By using optional car battery cord Hitachi VM-CC70A) 18

CHECKING THE BATTERY 19

CHARGING A BATTERY 20

MAKING A SAMPLE RECORDING 22

IDENTIFICATION AND OPERATION OF CONTROLS 26

 DATE/TIME Setting pg. 20 31

 To correct date/time information after starting the date/time 32

 To correct date/time information during programming 32

AUTOMATIC DATE RECORDING 33

PROGRAM AE (Auto Exposure) 34

AUTO FOCUS 35

 The auto focus will not work under the following conditions. 35

MANUAL FOCUS 37

POWER ZOOM 38

DIGITAL ZOOM 39

INSTANT ZOOM 40

MACRO 41

FADE IN/FADE OUT 42

 Fading In 42

 Fading Out 42

INDEX SIGNAL RECORDING 44

QUICK EDIT (Edit Search) 45

INSTANT REVIEW 46

DISPLAY BUTTON 47

LINEAR TIME COUNTER 48

REMAINING TAPE 49

TITLE RECORDING 50

 Creating a title 50

 Correcting errors during title storage 51

TABLE OF CONTENTS

Recording titles on a tape in the camera/recorder	52
Recording titles on another VCR while playing a tape back with the camcorder.....	52
Chart of characters available in the titler	52
RECORDING TV PROGRAMS	53
AUDIO DUBBING.....	55
AUDIO AND VIDEO DUBBING.....	57
AUTOMATIC REWIND.....	59
VIEWING THE PICTURE PLAYED BACK ON YOUR TV	60
STILL	62
FORWARD AND REVERSE SEARCH.....	63
MEMORY	64
CAMERA/RECORDER TO VCR DUBBING	65
FLYING ERASE HEAD	66
USING THE BUILT-IN CAMERA LIGHT	67
To replace the lamp of camera light	68
EYEPIECE ADJUSTMENT.....	69
VIEWFINDER BRIGHT, COLOR AND TINT CONTROLS.....	70
HOW TO ATTACH THE SHOULDER STRAP	71
TROUBLESHOOTING.....	72
CLEANING THE INSIDE OF THE ELECTRONIC VIEWFINDER.....	74
HEAD CLEANING	76
PERIODIC MAINTENANCE.....	77
SPECIFICATIONS	78
HOTLINE.....	79
ACCESSORY TO ADD MORE EXCITEMENT	80

WARNINGS

WARNING: TO PREVENT FIRE OR ELECTRIC SHOCK, DO NOT EXPOSE THIS APPLIANCE TO RAIN OR MOISTURE.

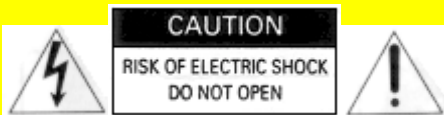

This symbol warns the user that uninsulated voltage within the unit may have sufficient magnitude to cause electric shock. Therefore, it is dangerous to make any kind of contact with any inside part of this unit.



This symbol alerts the user that important literature concerning the operation and maintenance of this unit has been included. Therefore, it should be read carefully in order to avoid any problems.

CAUTION:

TO PREVENT ELECTRIC SHOCK, MATCH WIDE BLADE OF PLUG TO WIDE SLOT, FULLY INSERT.

"This digital apparatus does not exceed the Class B limits for radio emissions from digital apparatus as set out in the interference-causing equipment standard entitled " Digital Apparatus", ICES-003 of the Department of Communications."

Warning: This device complies with Part 15 of the FCC rules. Operation is subject to the following two conditions: (1) This device may not cause harmful interference, and (2) this device must accept any interference received, including interference that may cause undesired operation.

Note: This equipment has been tested and found to comply with the limits for a Class B digital device, pursuant to Part 15 of the FCC Rules. These limits are designed to provide reasonable protection against harmful interference in a residential installation. This equipment generates, uses, and can radiate radio frequency energy and, if not installed and used in accordance with the instructions, may cause harmful interference to radio communications. However, there is no guarantee that interference will not occur in a particular installation. If this equipment does cause harmful interference to radio or

WARNINGS

television reception, which can be determined by turning the equipment off and on, the user is encouraged to try to correct by one or more of the following measures:

- Reorient or relocate the receiving antenna.
- Increase the separation between the equipment and the receiver.
- Connect the equipment into an outlet on a circuit different from that to which the receiver is connected.
- Consult the dealer or an experienced radio/TV technician for help.

Caution to the user: Changes or modifications not expressly approved by the manufacturer could void the user's authority to operate the equipment.

Caution: Avoid operating your camcorder immediately after moving it from a cold area to a warm humid area. Give the camcorder 2 to 3 hours to acclimate to the surroundings before inserting a video cassette. When moved from a cold area to a warm humid area, moisture may condense on the head drum inside the machine. This moisture could cause the tape to stick to the headwheel and damage the headwheel or tape.

See the bottom of the AC adaptor/charger. The rating and caution label is located on the bottom of the AC adaptor/charger.

WARNING: Many television programs and films are copyrighted. In certain circumstances, copyright law may apply to private in-home videotaping of copyrighted materials.

PRECAUTIONS

Thank you for choosing the **VHS** video camera/recorder. For maximum pleasure and convenience please read these simple instructions before operating your camera/recorder.

PRECAUTIONS

Any problems that occur as a result of any of the following conditions will not be covered by our warranty.

Be careful that no water, dust, or sand enters the camera/recorder.

When you are not using the camera/recorder, switch off the power and attach the lens cap.

When you shoot at a scene which contains an extremely bright object such as the sun or a light source, a bright vertical bar may appear in the picture.

Your camera/recorder is functioning properly, but the solid-state pickup device (CCD) usually causes this as an inherent characteristic. Try to avoid shooting an excessive bright object directly.

Be sure not to leave it in a place where the temperature exceeds 120° F (49° C), or the pickup device may be damaged.

Dangerous includes:

- Inside a car with the windows closed and in direct sunshine.
- Near heating appliances.

Do not point the electronic viewfinder to direct sunlight; it could damage the viewfinder.

The liquid crystal display (LCD) panel is made by highly precise technology. More than 99.99% of its picture elements (pixels) are effective, but some (less than 0.01%) may appear as coloured bright dots. This does not indicate a fault as the LCD panel stretches the limits of current technology.

FEATURES

- Digital zoom up to X24
- Solid-state camera pickup
- **HQ** High Quality picture technology
- Auto focus power zoom lens with macro feature
- Full record and playback capability with standard **VHS** cassette
- Program AE (Auto Exposure)
- Fade in/fade out
- Color electronic viewfinder (EVF)
- Flying erase head
- Time and date
- Titler
- Index signal
- Audio/video dub
- Audio dub
- Built-in camera light

* **HQ** This video camera/recorder with this marking incorporates **VHS** high-quality picture technology and is compatible with any video cassette recorder bearing the **VHS** mark.

ACCESSORIES

Check to make sure you have the following components and accessories (besides the camera/recorder unit itself) before disposing of the packing material.

1. Video/audio cord
2. Lead-acid rechargeable Battery
3. AC adaptor/Charger
4. Shoulder strap
5. DC cord

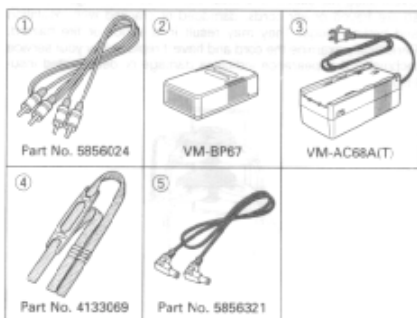

IMPORTANT SAFEGUARDS

In addition to the careful attention devoted to quality standards in the manufacture of your video product, safety is a major factor in the design of every instrument. But, safety is your responsibility too.

This page lists important information that will help to assure your enjoyment and proper use of a Video Camera/Recorder and accessory equipment. Please read it carefully before operating your video product and keep it in a handy place for future reference.

INSTALLATION

1 Read and Follow Instructions -- All the safety and operating instructions should be read before the video product is operated. Follow all operating and use instructions.



2 Retain Instruction -- The safety and operating instructions should be retained for future reference.

3 Heed Warnings -- Comply with all warnings on the video product and in the operating instructions.

4 Polarized Plug -- This video product is equipped with a polarized alternating-current line plug (a plug having one blade wider than the other). This plug will fit into the power outlet only one way. This is a safety feature. If you are unable to insert the plug fully into the outlet, try reversing the plug. If the plug should still fail to fit, contact your electrician to replace your obsolete outlet. To prevent electric shock do not use this polarized plug with an extension cord, receptacle or other outlet unless the blades can be fully inserted without blade exposure. If you need an extension, use a polarized cord.



5 Power Sources -- This video product should be operated only from the type of power source indicated on the marking label. If you are not sure of the type of power supply to your home, consult your video dealer or local power company. For video products intended to operate from battery power, or other sources, refer to the operating instructions.

6 Overloading -- Do not overload wall outlets and extension cords as this can result in a risk of fire or electric shock. Overloaded AC outlets and extension cords are dangerous, and so are frayed power cords, damaged or cracked wire insulation and broken plugs. They may result in shock or fire hazard. Periodically examine the cord

IMPORTANT SAFEGUARDS

and have it replaced by your service technician if appearance indicates damage or deteriorated insulation.



7 Power Cord Protection -- Power supply cords should be routed so that they are not likely to be walked on or pinched by items placed upon or against them, paying particular attention to cords at plugs, convenience receptacles, and the point where they exit from the appliance.

8 Ventilation -- Slots and openings in the cabinet are provided for ventilation to ensure reliable operation of the video product and to protect it from overheating. These openings must not be blocked or covered. The openings should never be blocked by placing the video product on a bed, sofa, rug or other similar surface. This video product should never be placed near or over a radiator or heat register. This video product should not be placed in a built-in installation such as a bookcase or rack unless proper ventilation is provided or the video product manufacturer's instructions have been followed.

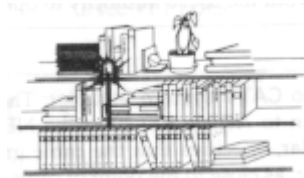

9 Attachments -- Do not use attachments unless recommended by the video product manufacturer as they may cause hazards.

Caution: Maintain electrical safety. Power-line operated equipment or accessories connected to this unit should bear the UL listing mark or CSA certification mark on the accessory itself and should not have been modified so as to defeat the safety features. This will help avoid any potential hazard from electric shock or fire. If in doubt, contact qualified service personnel.

10 Water and Moisture -- Do not use this video product near water -- for example, near a bath tub, wash bowl, kitchen sink, or laundry tub, in a wet basement, or near a swimming pool, and the like.

IMPORTANT SAFEGUARDS

11 Accessories -- Do not place this video product on an unstable card, stand, tripod, bracket or table. The video product may fall, causing serious injury to a child or adult, and serious damage to the appliance. Use only with a cart, stand, tripod, bracket or table recommended by the manufacturer, or sold with the video product. Any mounting of the product should follow the manufacturer's instructions, and should use a mounting accessory recommended by the manufacturer.

11A An appliance and cart combination should be moved with care. Quick stops, excessive force, and uneven surfaces may cause the appliance and cart combination to overturn.



12 Outdoor Antenna Grounding -- If an outside antenna or cable system is connected to the video product, be sure the antenna or cable system is grounded so as to provide some protection against voltage surges and built-up static charges. Section 810 of the National Electrical Code, ANSI/NFPA No. 70, provides information with respect to proper grounding of the mast and supporting structure, grounding of the lead-in wire to an antenna discharge unit, size of grounding conductors, location of antenna-discharge unit, connection to grounding electrodes, and requirements for the grounding electrode. See example below:

EXAMPLE OF ANTENNA GROUNDING

13 Power Lines -- An outside antenna system should not be located in the vicinity of overhead power lines or other electric light or power circuits, or where it can fall into such power lines or circuits. When installing an outside antenna system, extreme care should be taken to keep from touching or approaching such power lines or circuits as contact with them might be fatal. Installing an outdoor antenna can be hazardous and should be left to a professional antenna installer.

USE

14 Cleaning -- Unplug this video product from the wall outlet before cleaning. Do not use liquid cleaners or aerosol cleaners. Use a damp cloth for cleaning.

15 Object and Liquid Entry -- Never push objects of any kind into this video product through openings as they may touch dangerous voltage points or short-out parts that could result in a fire or electric shock. Never spill liquid of any kind on the video product.

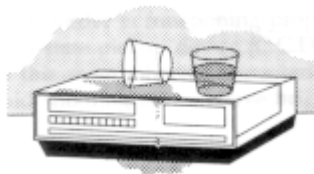

16 Lightning -- For added protection for this video product during a lightning storm, or when it is left unattended and unused for long periods of time, unplug it from the wall outlet and disconnect the antenna or cable-system. This will prevent damage to the video product due to lightning and power-line surges.



SERVICE

17 Servicing -- Do not attempt to service this video product yourself as opening or removing covers may expose you to dangerous voltage or other hazards. Refer all servicing to qualified service personnel.

18 Conditions Requiring Service -- Unplug this video product from the wall outlet and refer servicing to qualified service personnel under the following conditions.

- a. When the power-supply cord or plug is damaged
- b. If liquid has been spilled or objects have fallen into the video product.
- c. If the video product has been exposed to rain or water.
- d. If the video product does not operate normally by following the operating instructions. Adjust only those controls that are covered by the operating instructions. Improper adjustment of other controls may result in damage and will often require extensive work by a qualified technician to restore the video product to its normal operation.
- e. If the video product has been dropped or the cabinet has been damaged.
- f. When the video product exhibits a distinct change in performance -- this indicates a need for service.

19 Replacement Parts -- When replacement parts are required, have the service technician verify that the replacements he uses have the same safety characteristics as the original parts. Use of replacements specified by the video product manufacturer can prevent fire, electric shock or other hazards

20 Safety Check -- Upon completion of any service or repairs to this video product, ask the service technician to perform safety checks recommended by the manufacturer to determine that the video product is in safe operating condition.

21 Heat -- The product should be situated away from heat sources such as radiators, heat registers, stoves, or other products (including amplifiers) that produce heat.

IMPORTANT SAFETY INSTRUCTIONS FOR AC ADAPTER/CHARGER

1. **Save these instructions** - This page contains important safety and operating instructions for AC Adaptor/Charger Model VM-AC68A (T)
2. Before using AC Adaptor/Charger, read all instructions and cautionary markings on (1) AC Adaptor/Charger, (2) battery and (3) product using battery.
3. Also read all instructions on pages 4 and 5.

4. Caution--To reduce the risk of injury, charge only rechargeable battery, VM-BP64/BP65/BP66/BP67. Other types of batteries may burst causing personal injury and damage.

5. Do not expose charger to rain or snow.
6. Use of an attachment not recommended or sold by the battery charger manufacturer may result in a risk of fire, electric shock, or injury to persons.
7. To reduce the risk of damage to electric plug and cord, pull by plug rather than cord when disconnecting charger.
8. Make sure cord is located so that it will not be stepped on, tripped over, or otherwise subjected to damage or stress.
9. Do not operate charger with damaged cord or plug - replace them immediately.
10. An extension cord should not be used unless absolutely necessary. Use of improper extension cord could result in a risk of fire and electric shock. If extension cord must be used, make sure:
 - A. That the pins on plug of extension cord are the same number, size, and shape as those of plug on charger.
 - B. That extension cord is properly wired and in good electrical condition; and
 - C. That wire size should be met below:

Minimum AWG size	Length of extension cord (feet)
18	Equal to or less than 100
16	Equal to or less than 150
11. Do not operate charger if it has received a sharp blow, been dropped, or otherwise damaged in any way; take it to a qualified serviceman.
12. Do not disassemble charger; take it to a qualified serviceman when service or repair is required. Incorrect reassembly may result in a risk of electric shock or fire.
13. To reduce the risk of electric shock, unplug charger from outlet before attempting any maintenance or cleaning.

"Note to CATV system installer: This reminder is provided to call the CATV system installer's attention to Article 820-40 of the NEC that provides guidelines for proper grounding and, in particular, specifies that the cable ground shall be connected to the grounding system of the building, as close to the point of cable entry as practical".

ELECTRONIC VIEWFINDER

Set the viewfinder to the position shown in the figure when carrying the camcorder or storing it in the carrying case.

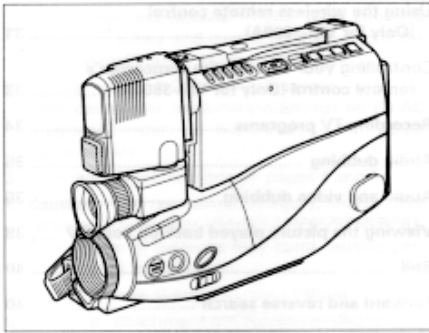

Turn the viewfinder to the position shown below when shooting pictures.

1. Turn the viewfinder

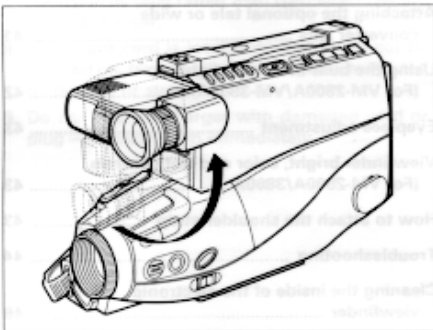

2. Turn the eyepiece.

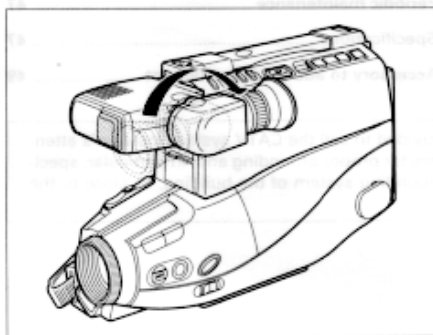

You can adjust the position and angle of the viewfinder so you can see through it easily.

Cautions:

- Do not force the viewfinder to rotate completely around. This will damage the viewfinder and/or camcorder.
- When pulling the viewfinder out or returning it to its original position, hold the viewfinder by the swivel selection. Do not hold the diopter control side.

ELECTRONIC VIEWFINDER

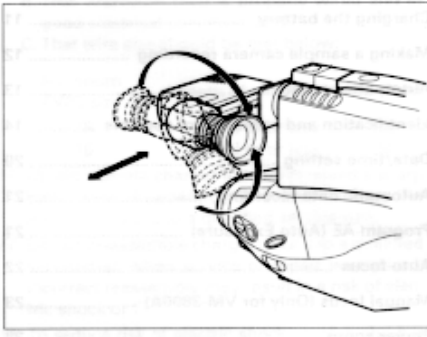

POWER SOURCES

WHEN USING WITH THE BATTERY (Provided)

- To attach, align the mark "▶" of the battery with that of the camera/recorder so that the battery fits into the grooves, and slide the battery downward, as illustrated.

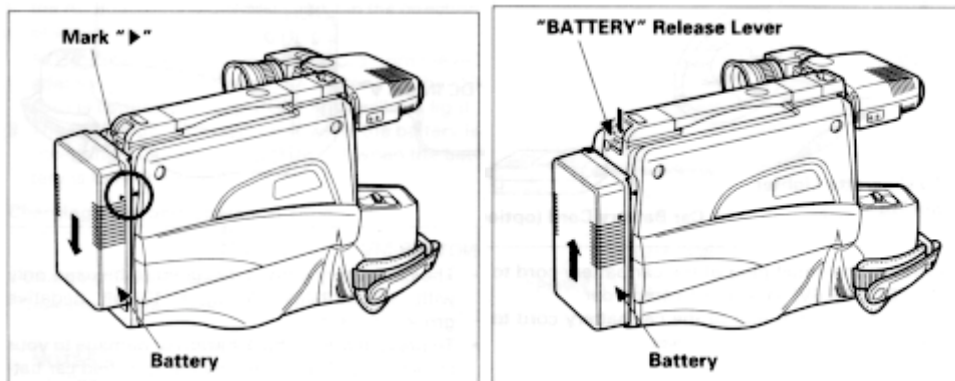

- To remove the battery:
Push and hold "**Battery**" release lever, then slide the battery to the upside and remove.

WHEN USING WITH THE AC ADAPTER/CHARGER (Provided)

1. Plug the AC adaptor/charger power cord into AC electrical outlet.
2. Connect one end of the DC cord (provided) to the "**DC IN 9.6V**" of the camera/recorder.
Connect the other end of the DC cord to the "**DC OUTPUT**" of the AC adaptor/charger.

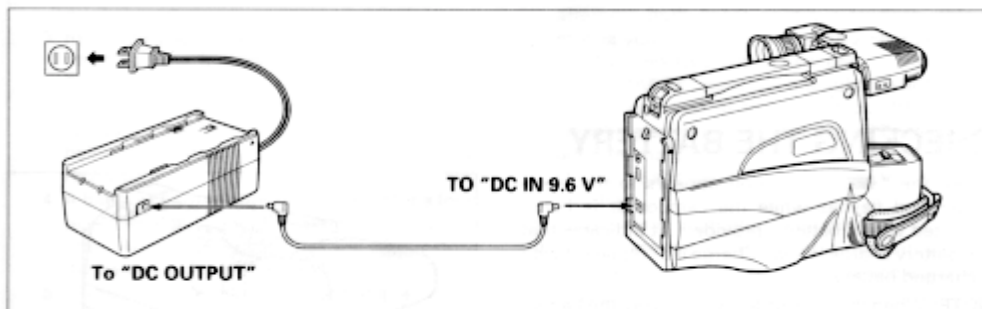
**NOTES:**

- The AC adaptor/charger cannot charge the battery and operate the camera/recorder at the same time.

POWER SOURCES

- When using the AC adaptor/charger to power the camera/recorder, the battery level indicator may display "Ⓞ AUTO". This indicator is used for battery operation and has no meaning when using the AC adaptor/charger to power the camera/recorder.

WHEN USING WITH THE CAR BATTERY (By using optional car battery cord Hitachi VM-CC70A)

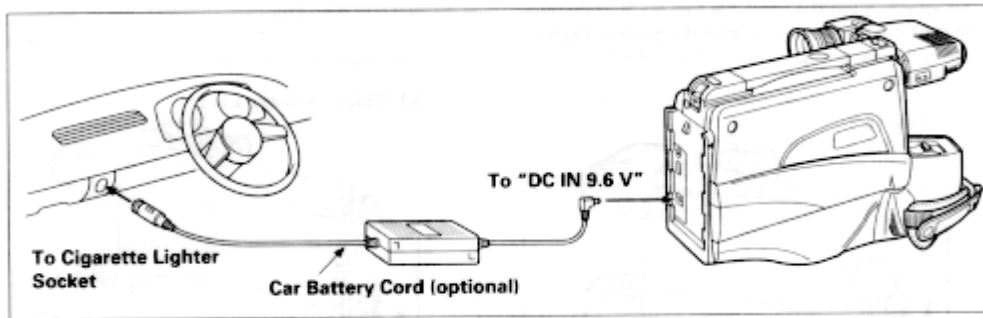

1. Connect the small plug of the car battery cord to the "DC IN 9.6V" jack of the camera/recorder.
2. Connect the other end of the car battery cord to the car's cigarette lighter socket.

NOTES:

- The car battery cord is designed to be used only with automobiles having a 12-volt negative ground system.
- To prevent fire or shock hazard or damage to your camera/recorder, please use only the specified car battery cord.

CHECKING THE BATTERY

When the "🔋" indication appears in the viewfinder and flashes while the camera/recorder is being operated with a battery (provided), it indicates that the battery charge is low. Charge it or replace it with a charged battery.

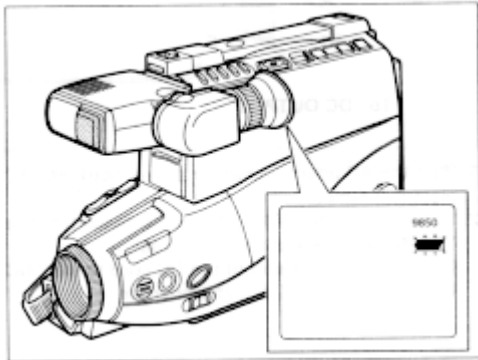

NOTE: When the camera/recorder is turned on, the battery level indicator "🔋" is displayed in the viewfinder indicating the condition of camera/recording battery. When the battery is fully charged, "🔋" is displayed.

After several minutes, the symbol will change to "🔋 AUTO". When the battery is very near empty, the symbol will change to "🔋 AUTO" and start blinking. You should find an alternative power source or recharge the battery before continuing to use your camera/recorder.



CHARGING A BATTERY

1. Plug the AC adaptor/charger power cord into AC electrical outlet.
2. Attach the battery to the AC adaptor/charger. Align the mark "▼" on the battery with that of AC adaptor/charger and push the battery flush with the AC adaptor/charger and slide it in the direction of arrow.

NOTE: You must remove the DC cord from the AC adaptor/charger to charge the battery. If the DC cord is connected, "**CHARGE**" light will not light.

3. The "**CHARGE**" light will be lit while the battery is accepting a charge, and will go out when the battery is fully charged.

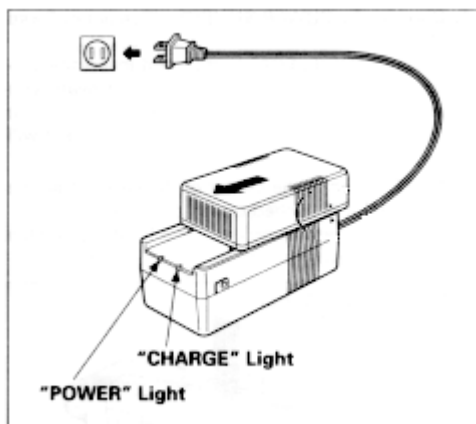

NOTES:

1. The time required for charging the battery is approx. three hours.
2. When fully charged, the battery should supply approx. 90 ~ 120 minutes of operating time (depending on how much you use zoom and pause).
2. Charge the battery after use and store it at normal room temperature.
3. Recharge the battery at least once every six months. The battery is a lead-acid battery. This battery tends to discharge if not used for an extended period of time. If the battery is stored for an extended length of time without being recharged, you may not be able to recharge it.
4. A battery charged after being stored for a long period may not supply power for the specified time. Additional rechargings will help restore the battery's operation time.
5. The battery should be charged at a temperature of 50°F - 86°F (10°C - 30°C) to prevent damage.
6. Do not operate the battery at temperatures below 14°F (-10°C) or above 95°F (35°C). The battery may be damaged if operated at temperatures above 122°F (50°C). Operation time will decrease at extremely low temperatures.
7. After repeated chargings and use, the operation time will gradually decrease. When operation time becomes too short to be useful, it is time to replace the battery.
8. If "**CHARGE**" and "**POWER**" lights on the AC adaptor/charger start flashing, remove the battery and then reattach it. If after several attempts both lights continue to flash, this means your battery cannot take a charge and must be replaced with a new one. The "**CHARGE**" light will not light if a hot battery is attached to the AC adaptor/charger. Attaching an extremely hot battery to the adaptor/charger is not recommended; it should be allowed to cool down before being attached.
9. Do not short the battery's terminal.
10. Do not attempt to disassemble or modify the battery. There are no user serviceable parts inside.
11. Throwing the battery into a fire or exposing the battery to excessive heat - over 149°F (65°C) could be hazardous.
12. Be sure to set the "**POWER**" switch to the "**OFF**" position before removing the battery.

ATTENTION:

The product that you have purchased contains a rechargeable battery. The battery is recyclable. At the end of its useful life under various state and local laws, it may be illegal to dispose of this battery into the municipal waste stream. Check with your local solid waste officials for details in your area for recycling options or proper disposal.



MAKING A SAMPLE RECORDING

1. Connect the POWER SOURCE. (See pages 9 and 10.)
2. Press "**STOP/EJECT**" button and insert the cassette so the transparent window is toward you and the arrow toward the cassette holder. Slide the cassette into cassette holder as far as it will go.

NOTE: Push in the center of the cassette all the way until it is latched by the cassette holder.

3. Press the cassette holder. The holder will latch in the operating position.

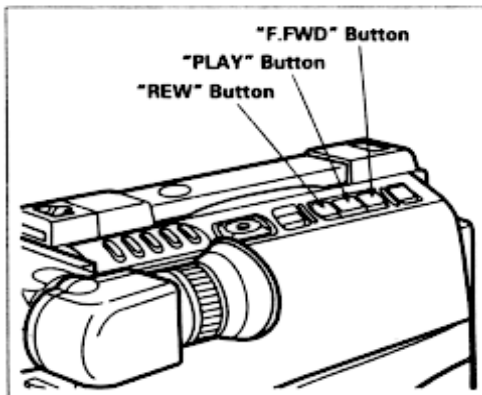

4. Press and hold the small button on "**POWER**" switch, and then slide it to the "**CAM**" position. The "**POWER**" indicator will light and the camera/recorder will enter record/pause mode automatically.

NOTES:

- If the erase prevention tab on the cassette is removed, the "**TAPE**" indication in the viewfinder flashes for several seconds and the camera/recorder will not enter record/pause mode.
- See page 39 for "**EYEPIECE ADJUSTMENT**".

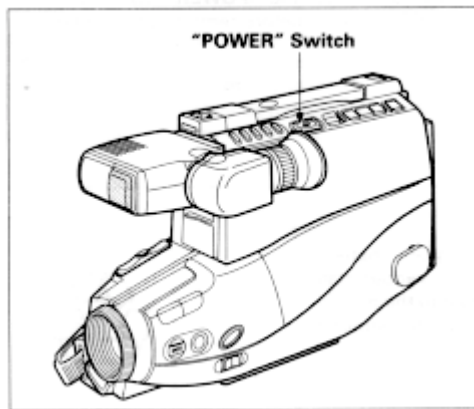

5. Now, press **"REC/PAUSE"** button to start shooting the picture. The **"REC"** indication appears in the viewfinder and you are now recording the picture you see through the viewfinder.

6. Press **"REC/PAUSE"** button to stop recording. Press the button again to resume recording. The **"II"** indication will appear in the viewfinder instead of **"REC"** while the camera/recorder is in the record/pause (stand-by) mode.

NOTES:

- The **"TAPE END"** indication starts flashing in the viewfinder when there is about five minutes recording time left on the cassette.
- If the record/pause mode continues for more than 5 minutes, the camera/recorder's power is automatically turned off. To turn on again, press **"REC/PAUSE"** button. The camera/recorder enters record/pause (stand-by) mode.

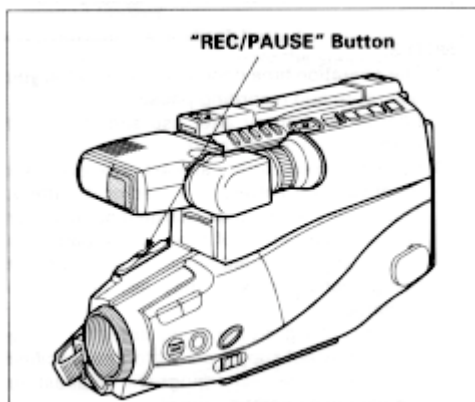

7. After recording, press and hold the small button on the **"POWER"** switch, and then slide it to **"VIDEO"**. The camera/recorder will now be in the stop mode.

MAKING A SAMPLE RECORDING

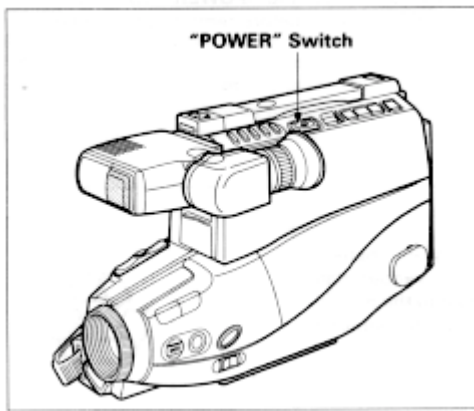

8. Press **"REW"** button. The tape will be rewound to the beginning
9. Press **"PLAY"** button. The picture you just recorded will be seen through the viewfinder.

NOTE: If you connect the camera/recorder to your TV, you can see the picture played back on your TV. Refer to **"VIEWING THE PICTURE PLAYED BACK ON YOUR TV"** on page 34.

10. After playing, press **"STOP/EJECT"** button

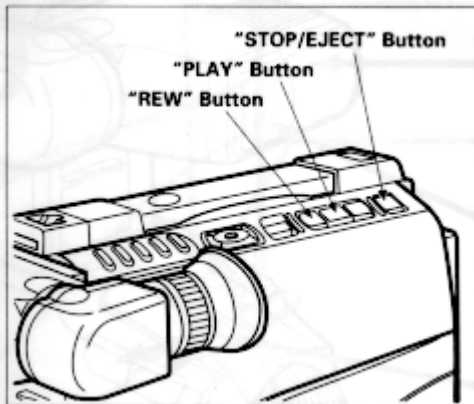

11. Slide the **"POWER"** switch to **"OFF"** position to turn off the camera/recorder. Press **"STOP/EJECT"** button to remove the cassette.

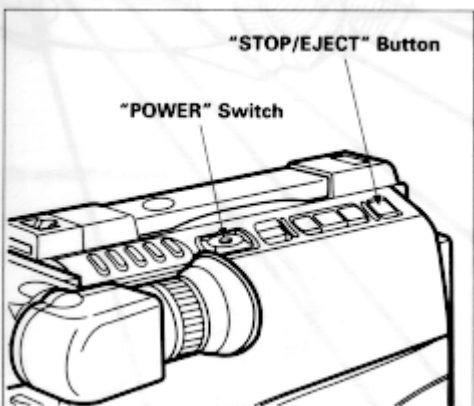

12. Always remove the power source from the camera/recorder after use.

MAKING A SAMPLE RECORDING

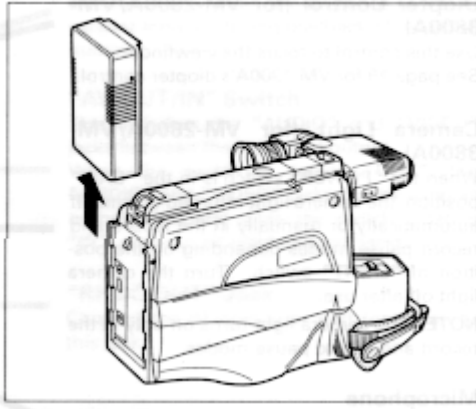

NOTE: If you have a cassette tape that has already been partially recorded on and you want to record the remaining blank section, see "**QUICK EDIT**" on page 26.

IDENTIFICATION AND OPERATION OF CONTROLS

Diagram of camera

Diopter Control

Use this control to focus the viewfinder.

Camera Light

When the "**POWER**" switch is in the "**CAM**" position, the camera light is turned on and off automatically or manually in the record and record/pause modes depending on the position of "**LIGHT**" switch. Turn the camera light off after use.

NOTE: The camera light turns on only in the record and record/pause modes.

Microphone

Sensitive to sounds coming from the direction in which the camera is pointed.

"FOCUS" Control (AUTO/MAN) Button

Press these buttons simultaneously to select manual or automatic focus. For manual focusing, press the ◀ or ▶ button to bring the subject into focus. When using manual focus, "**FOCUS**" appears in the viewfinder.

Lens (with Lens Cap)

F1.8 (5 ~ 60 mm) 12:1 power zoom lens features auto focus and auto iris functions.

"FADE" Button

During recording you can add a professional touch to your recordings by fading in and out of scenes. You can select three fade modes - the white fade, wipe fade, and zoom fade.

NOTE: When you fade scenes in and out, the sound will also fade in and out with the picture. (See page 25.)

"INST.ZOOM" (Instant Zoom) Button

Use this button to magnify the image being recorded 1.5 times momentarily

"LIGHT" Switch

When this switch is set to "**AUTO**", the camera light turns on or off automatically

according to the brightness of the object. When the switch is set to **"ON"**, the camera light turns on. Set the switch to **"OFF"** to turn the light off manually.

Electronic Viewfinder (EVF)

Displays what the camera/recorder lens sees. The electronic viewfinder also functions as a convenient color monitor during playback of recorded material.

"AV OUT/IN" Switch

This switches the **"AUDIO"** and **"VIDEO"** jacks between the input and the output. When the switch is set to **"OUT"**, the **"AUDIO"** and **"VIDEO"** jacks can be used as output jacks, and when the switch is set to **"IN"**, they can be used as input jacks.

"RF DC OUT" Jack

Connect the RF converter unit (optional) to this jack.

"AUDIO/VIDEO" Jacks

These can be used as input or output jacks depending on the position of **"AV OUT/IN"** switch.

- When using these jacks as outputs, connect the audio/video cord (provided) to these jacks and to the audio and video inputs of your TV/monitor receiver. You can also connect the RF converter unit (optional) to these jacks and your TV receiver.
- Use these jacks as inputs when you supply signals from another device to your camera/recorder for recording.

To open the cover:

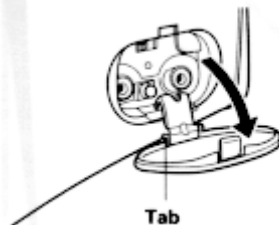

To close the cover, first hook the tab onto the case.



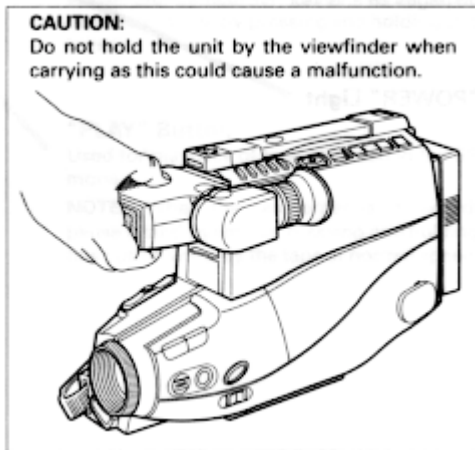

Diagram of Buttons

"TITLE" Button

Press this button to create and record personalized titles on your videos with the camera/recorder's built-in titler.
(See **"TITLE RECORDING"** on page 28.)

"DATE / TIME" Button

Press this button to display the date and time in the viewfinder.
Whenever the date and time appear in the viewfinder, they will be recorded on the tape.

"RESET" Button

When the linear time counter is displayed in the viewfinder, pressing this button resets the counter to "0:00:00".

"REVIEW" Button

Used to review the last few seconds of the recorded segment in the record/pause mode.
(See **"INSTANT REVIEW"** on page 26.)

"DISPLAY" Button

If this button is pressed, **"M"** appears beside the tape counter in the viewfinder and the tape's position is stored in memory. If the camera/recorder is connected to a TV/monitor receiver, the same display as that in the viewfinder appears on the screen when the **"M"** is displayed.
(See **"DISPLAY BUTTON"** and **"MEMORY"** on pages 27 and 36.)

"POWER" Switch

This switch changes the camera/recorder to the record mode or to the playback mode. Press and hold the small button on this switch, and then slide it to **"CAM"** or **"VIDEO"**.

"DUBBING AUDIO/VIDEO" Button

- This button is used to record new audio in place of existing audio without erasing the video. See page 31.

IDENTIFICATION AND OPERATION OF CONTROLS

- This button is used to record new video in place of existing video and audio. See page 32.

"REW" Button

Press this button during stop or fast forward mode, and fast-rewinding starts. "◀◀" appears in the viewfinder. Press the button during playback of tape, and the tape is played back in the rewind direction approximately 3 times faster than the normal speed to confirm the recorded contents.

Press "**PLAY**" button to return to normal playback mode or press "**STOP/EJECT**" button to stop tape movement.

NOTE: You can also visually scan backward when the camera/recorder is in record/pause (stand-by) mode by pressing and holding this button.

"STOP/EJECT" Button

- The "**STOP/EJECT**" button is used to stop playback, rewind, and fast forward operations. The "**STOP/EJECT**" button has no effect during record operation.

"F.FWD" Button

Press this button during stop or rewind mode, and fast-forwarding starts. "▶▶" appears in the viewfinder.

Press the button during playback of tape, and the tape is played back in the forward direction approximately 3 times faster than the normal speed to confirm the recorded content.

Press "**PLAY**" button to return to normal playback mode or press "**STOP/EJECT**" button to stop tape movement.

NOTE: You can also visually scan forward when the camera/recorder is in record/pause (stand-by) mode by pressing and holding this button.

"PLAY" Button

Used for playback of tape recorded in the SP mode.

NOTE: When the camera/recorder is in the record/pause (stand-by) mode, pressing and holding this button will play the tape at normal speed.

(REW, PLAY, F.FWD, and STOP/EJECT)

- These buttons are used for title making buttons when the "**TITLE**" button is pressed. (See "**TITLE RECORDING**" on page 28.)
- These buttons may be also used to set the date and time during pause (stand-by) mode. (See "**DATE/TIME SETTING**" on page 20.)

Diagram of Camera

"BATTERY" Release Lever

Releases the battery attached to the video camera/recorder.

Cassette Holder

Press "**STOP/EJECT**" button to open the cassette holder. Be aware of the cassette direction when inserting.

NOTE: Power source must be connected to open the cassette holder.

"DC IN 9.6V" Jack

When using the AC adaptor/charger (provided) or the car battery cord (optional), connect this jack and the "**DC OUTPUT**" of the AC adapter/charger or the car's cigarette lighter socket.

Graphics in the Electronic Viewfinder

"BRIGHT", "COLOR" and "TINT" controls

Use to adjust the picture color in the viewfinder. See page 39.

"REC/PAUSE" Button

This button is used to control the camera/recorder. When the "**POWER**" switch is set to the "**CAM**" position, pressing this button starts the tape to begin recording. "**REC**" appears in the viewfinder.

When this button is pressed again, " **||** " appears instead of "**REC**" and the tape stops and the camera/recorder enters the record/pause (stand-by) mode.

NOTE: This button may be also used to display a still picture during the playback mode.

Power Zoom Switch/ "TRACKING" Control

- This switch performs zooming electrically.
 - "W": Picture becomes wider gradually.
 - "T": Picture becomes telescopic gradually.
- Used when playing a tape recorded on another VCR. Adjust for best picture. Ejecting the cassette returns the tracking to the normal position.

Lens Cap Tab

- Place the lens cap on this tab when you are ready to record a scene. The tab also prevents the lens cap from swinging around on its cord.

Hand Strap

Adjust to best fit your hand.

The date and time can be recorded on your tape to act as a handy reference when viewing them at a later time.

Use the following procedure to set up this display for the current date and time.

The time backup battery is rechargeable. Charge the backup battery every two months. Set **"POWER"** switch to **"OFF"** position and connect a charged battery or AC adaptor/charger to the camera/recorder for 24 hours. Make sure that the current time is displayed correctly before you start recording.

NOTES:

- The backup battery should be charged every two months. If it is not charged periodically, it will be over-discharged and its life will be shortened.
- A cassette cannot be loaded or ejected when setting the date and time.

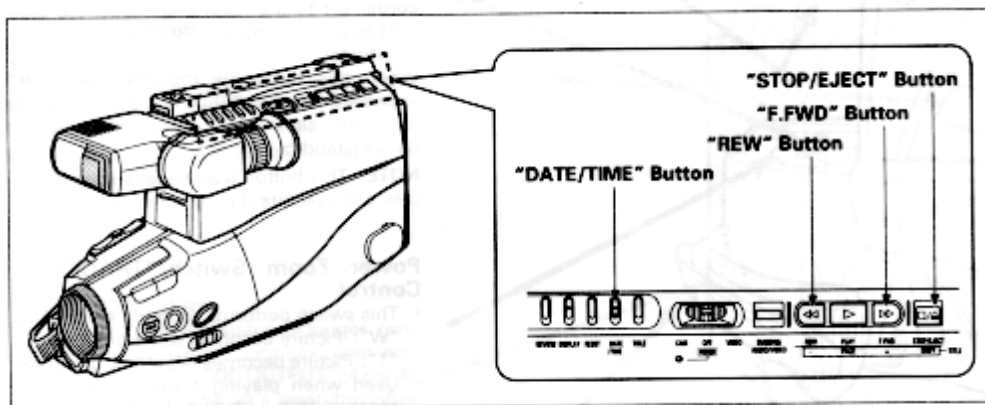

1. Press and hold the small button on **"POWER"** switch, and then slide it to **"CAM"** position.

2. Press **"DATE/TIME"** button.

Date and time appear in the viewfinder and "1" flashes.

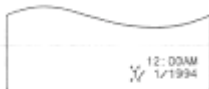

3. Press **"F.FWD"** button to select correct month. Hold button down to advance rapidly. If you go past the month you want to set, press **"REW"** button. When the correct month appears, press **"STOP/EJECT"** button.

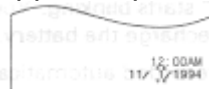

4. Press **"F.FWD"** button to select correct date. Hold button down to advance rapidly. If

you go past the date you want to set, press **"REW"** button. When the correct date appears, press **"STOP/EJECT"** button.

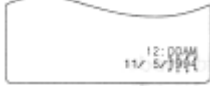

5. Press **"F.FWD"** or **"REW"** button to select year, and then press **"STOP/EJECT"** button.

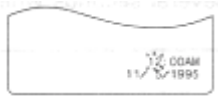

6. Press **"F.FWD"** or **"REW"** button as many times as may be required to select the correct hour, and then press **"STOP/EJECT"** button.

7. Repeat step 6 to select minute and AM/PM.



8. After setting AM or PM, press **"DATE/TIME"** button to change the display and start the internal clock. It is recommended that you press **"DATE/TIME"** button to match the time signal.

9. Press **"DATE/TIME"** button after setting the clock. The display will change as follows each time the button is pressed.

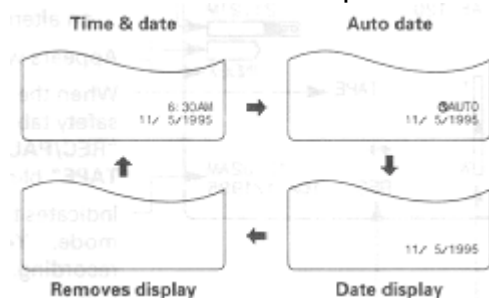

NOTE: The date/time graphics will be recorded whenever they appear in the viewfinder.

To correct date/time information after starting the date/time

1. Press and hold **"DATE/TIME"** button, and then press **"STOP/EJECT"** button. The month starts flashing.
2. Correct the incorrect digit by using **"F.FWD"**, **"REW"** and **"STOP"** buttons.

To correct date/time information during programming

Press **"STOP/EJECT"** button repeatedly until the digit that is incorrect flashes. Correct the incorrect digit by using **"F.FWD"**, **"REW"** and **"STOP/EJECT"** buttons.

AUTOMATIC DATE RECORDING

This feature records the date automatically once a day. After you begin recording, the date is recorded automatically for 10 seconds. The same date is recorded again in the following cases.

- When the cassette is replaced.
- When "⌚ AUTO" is displayed again after being switched to the date display.
- When the recording is for less than 10 seconds.

If the date changes while recording continues over 10 seconds, the date is recorded for 10 seconds when recording is restarted after the camera/recorder has been set to the standby mode.

Press "**DATE/TIME**" button until "⌚ AUTO" and the date appear in the viewfinder before you begin to record. The date will be recorded whenever it appears in the viewfinder.

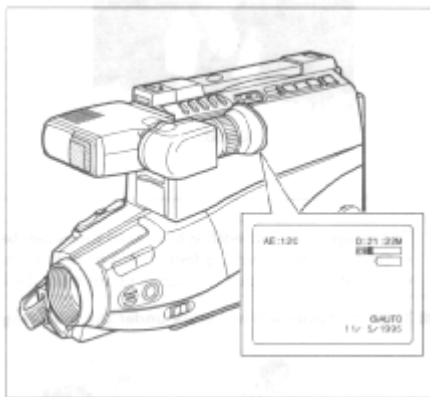

PROGRAM AE (Auto Exposure)

Program AE automatically selects the shutter speed 1/60, 1/100, 1/120, 1/180, 1/250, 1/350, 1/500, 1/750, 1/1000, 1/1500, 1/2000 or 1/4000 second that is optimum for the brightness of the subject. The iris is also adjusted automatically in response to the shutter speed.

AUTO FOCUS

- You can always focus the object automatically.

- The subject at the center of the viewfinder is in focus.



Good



No good

The range of the object with which auto focus can be used.

- On "T" side: about 3.6 feet (1.1m) from the lens surface to infinity.
- On "W" side: about 1.2 inches (3cm) from the lens surface to infinity.

The auto focus will not work under the following conditions.



1. Objects not in the center of the viewfinder.



2. Objects at far and near positions at the same time.



3. Objects lit by a spotlight or neon signs, etc.



4. Objects behind glass with water droplets or dust on it.

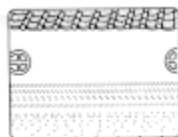

5. Objects with almost no difference in brightness such as a white wall.



6. Objects moving rapidly.



7. Dark objects.

MANUAL FOCUS

1. Press the FOCUS control (AUTO/MAN) buttons simultaneously. "**FOCUS**" appears in the viewfinder. You can adjust the focus manually.
2. Use the power zoom T control to zoom up completely to your subject. If you don't use the T control to zoom to the picture you want, the picture may fall out of focus when actual recording starts.
3. Pressing the FOCUS control (AUTO/MAN) ◀ (far) or ▶ (near) button until the subject is in focus.
4. Use the power zoom W control to zoom back to the picture you desire.

NOTE: To return to auto focus press the FOCUS control (AUTO/MAN) buttons and "**FOCUS**" disappears from the viewfinder.

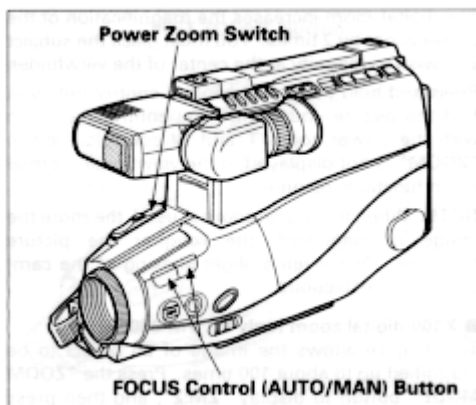

POWER ZOOM

- Press power zoom switch on the "W" side, and the picture gradually widens.

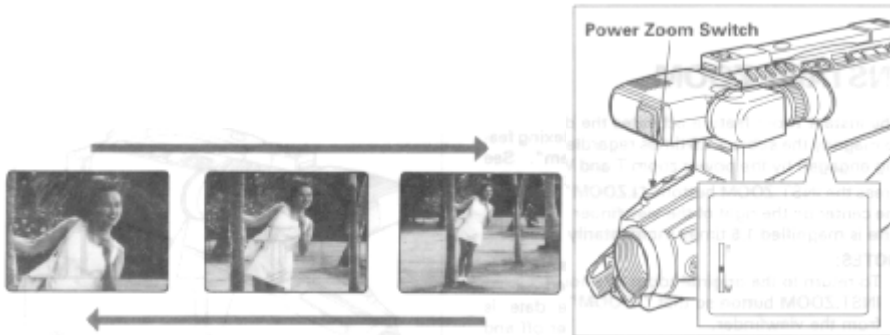

- Press the power zoom switch on the "T" side, and the picture gradually becomes telescopic.
- The zooming speed is slow when the power zoom switch is pressed lightly, and the zooming speed is fast when the switch is pressed strongly.
- When power zoom switch is operated, the zoom position is displayed in the viewfinder in 10 steps for several seconds.

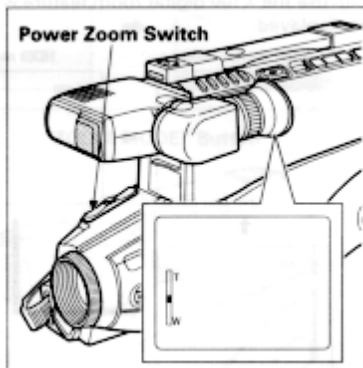

DIGITAL ZOOM

The digital zoom increases the magnification of the power zoom by 2 times. You must place the subject you wish to magnify at the center of the viewfinder. Press and hold the power zoom T control until you find the picture you want. You control the zoom with the power zoom T and W controls. When "**ZOOM**" is not displayed in the viewfinder, normal zoom functions resume.

NOTE: When the digital zoom is used, the more the image is magnified, the rougher the picture becomes. Also even a slight shaking of the camcorder is conspicuous.

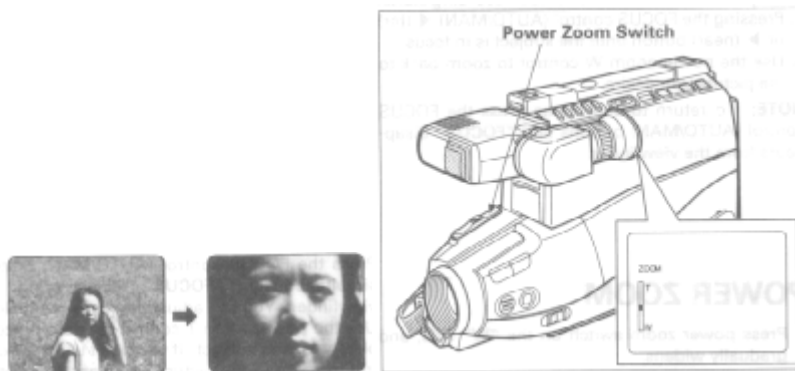

INSTANT ZOOM

The instant zoom feature activates the digital zoom to magnify the subject 1.5 regardless of zooming engaged by the power zoom T and W controls. Press the INST. ZOOM button. **"I.ZOOM"** appears in the viewfinder and the picture is magnified 1.5 times.

NOTES:

To return to the original zoom position, press the INST. ZOOM button so that **"I.ZOOM"** disappears from the viewfinder.

When the instant zoom is used, the more the image is magnified, the rougher the picture becomes. Also even slight shaking of the camcorder is conspicuous.

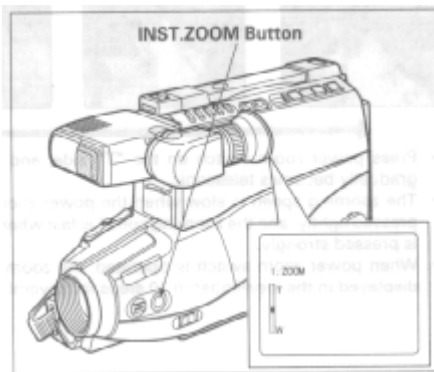

MACRO

Allows you to shoot objects as close as 1.2 inches (3 cm) from the lens tip. Press and hold "W" side of power zoom switch. An object is auto focused.

NOTES:

- Determine the size of the object by moving the camera backward and forward.
- Be careful as the lighting may tend to be insufficient when shooting in the above conditions.

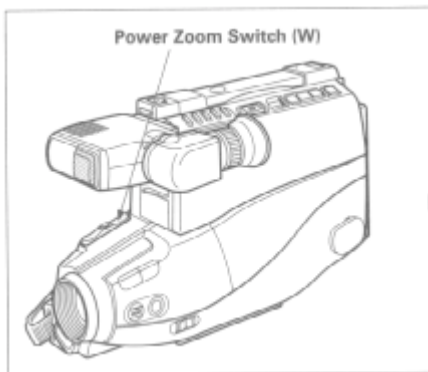

FADE IN/FADE OUT

Use the fade feature to add a professional touch to your recordings. Use the FADE button to select one of the three fade options.

White fade: Fades in from a white screen or fades out to a white screen. "☰" appears in the upper left corner of the viewfinder.

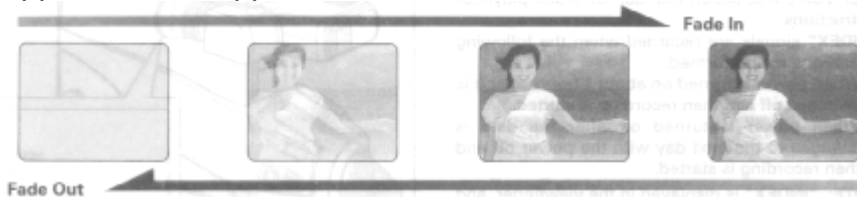

Wipe fade: The picture opens gradually from the center of a black screen or closes into the center to a black screen. "☐" appears in the upper left corner of the viewfinder.

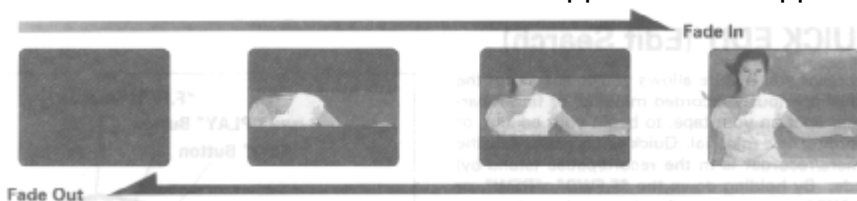

Zoom fade: Fades in while zooming from a white screen or fades out while zooming to a white screen. "☐" appears in the upper left corner of the viewfinder.

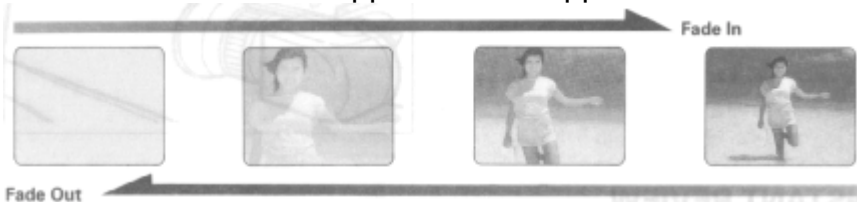

Fading In

1. Use the FADE button to select a fade option before recording.
2. Press the "REC/PAUSE" button to start recording; fade then begins automatically.

Fading Out

1. While recording with the camcorder use the FADE button to select option.
2. Press the "REC/PAUSE" button to stop recording; the fade begins automatically and "REC" flashes until the fade ends.

FADE IN/FADE OUT

NOTE: When fading out be sure to wait until the PAUSE indicator (⏸) is visible in the viewfinder before attempting to pit the camcorder into the record mode again.

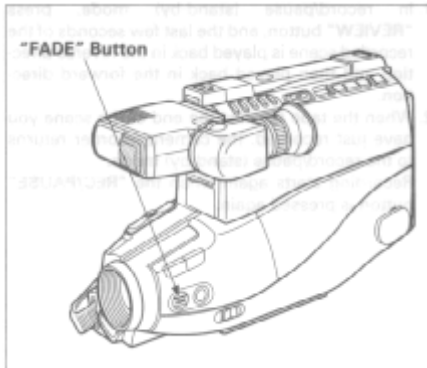

INDEX SIGNAL RECORDING

Indexing your tapes while recording makes it easy to find desired program segments when you play back the tape in a VCR that has a compatible indexing feature called the "VHS Index Search System". See your VCR's instruction manual for index playback instructions.

"INDEX" signals are recorded when the following operations are performed.

- When power is turned on about 4 hours after it is switched off and then recording is started.
- When power is turned on after the date is changed to the next day with the power off and then recording is started.

NOTE: "INDEX" is displayed in the viewfinder, and when an "INDEX" signal is recorded, "INDEX" disappears.

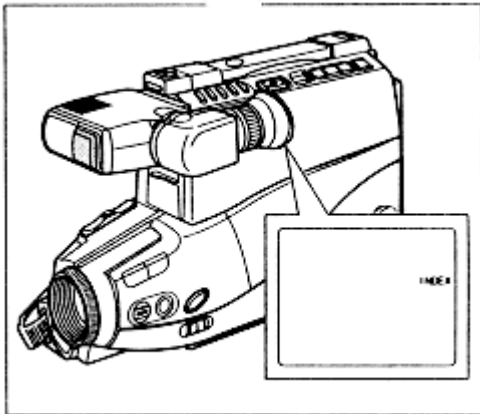

QUICK EDIT (Edit Search)

The quick edit feature allows you to search for the end of previously recorded material, or find a particular spot on your tape, to begin your editing, or recording new material. Quick edit is used while the camera/recorder is in the record/pause (stand-by) mode. By holding down the "**F.FWD**", "**REW**", or "**PLAY**" button, you can visually search or play your tape. Releasing the buttons ("**F.FWD**", "**REW**", or "**PLAY**") immediately stops the tape at that position.

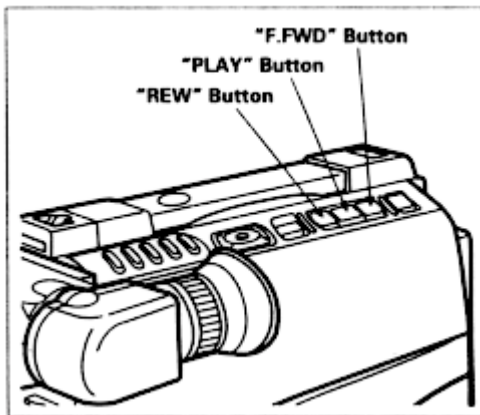

INSTANT REVIEW

1. In record/pause (stand-by) mode, press "**REVIEW**" button, and the last few seconds of the recorded scene is played back in the reverse direction and then played back in the forward direction.
2. When the tape reaches the end of the scene you have just recorded, the camera/recorder returns to the record/pause (stand-by) mode. Recording starts again when the "**REC/PAUSE**" button is pressed again.

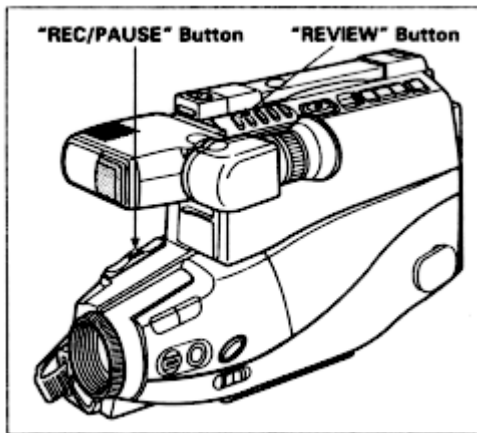

DISPLAY BUTTON

Each time the "**DISPLAY**" button is pressed, the display in the viewfinder switches as follows.

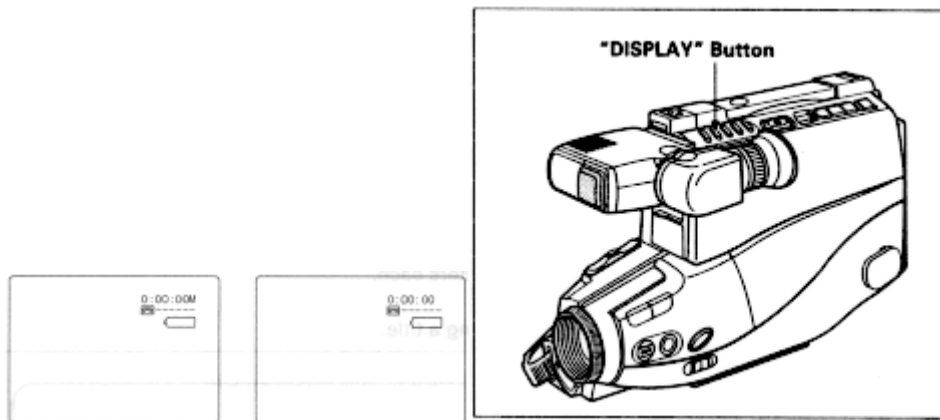

When the linear time tape counter with memory is displayed in the viewfinder, the same display appears on the screen of the connected TV/monitor receiver.

LINEAR TIME COUNTER

Shows length of tape run in hours, minutes and seconds.

Load a cassette into the camera/recorder and perform recording or playback; the counter indicates the elapsed time.

NOTES:

- The linear time counter does not operate when nothing is recorded on the tape.
- Counter changes to 0:00:00 when cassette is ejected.

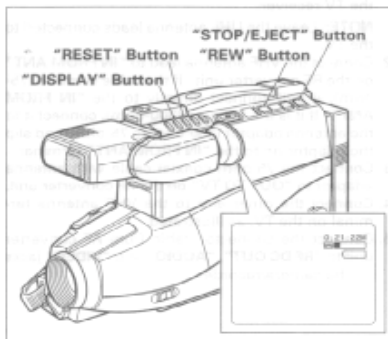

REMAINING TAPE

The tape remaining display shows the remaining tape that can be used for recording and playback, using seven dashes. This feature is handy when recording since it lets you know how long you can record on the loaded tape.

Insert a cassette in the camera/recorder and start recording or playback; 10 seconds later, the remaining tape will be displayed. When the cassette is ejected, the display will disappear. " [camera icon] -----" is displayed for 10 seconds after the tape starts to run.

NOTE: When the remaining recording tape time becomes less than about five minutes, "TAPE END" flashes in the viewfinder.



TITLE RECORDING

You can easily create and record personalized titles on your videos with the camera/recorder's built-in titler. The titler will store 2 different title pages in memory. Once a title is stored, it can be displayed and recorded at any time. Each title page can contain two lines of 16 characters each. The titler contains 47 different characters for creating titles.

NOTE: A cassette cannot be loaded or ejected when creating a title.

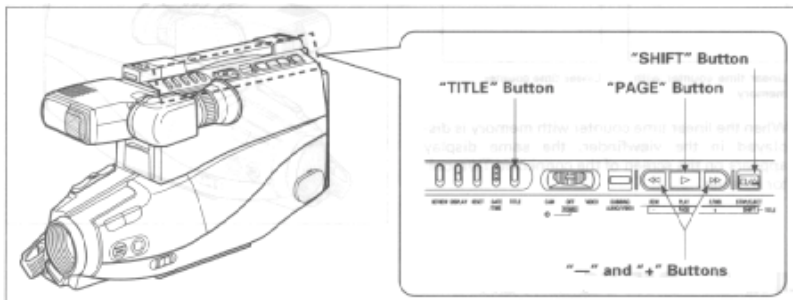

Creating a title

1. Attach a power source to the camera/recorder and slide **"POWER"** switch to either **"CAM"** or **"VIDEO"** position.
2. Press **"TITLE"** button. The flashing cursor will appear in the viewfinder.

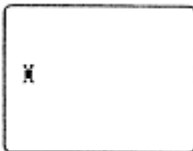

3. Press **"SHIFT"** button repeatedly to move the flashing cursor to the place you want to begin your title.
4. Select the first character for your title by pressing the **"-"** or **"+"** button repeatedly until the desired character appears.

NOTE: Each title can contain up to two lines of 16 characters each. A chart showing the characters contained in the titler is located on page 29.

TITLE RECORDING

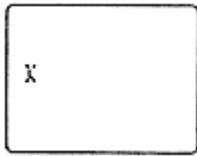

5. After you have selected the first character, press "**SHIFT**" button to move the flashing cursor to the place you want the next character.

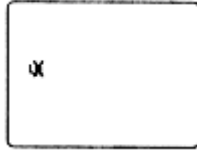

6. Repeat steps 4 and 5 until you have completed the title.

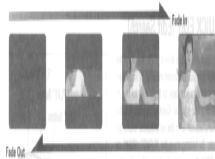

NOTE: Character may flash, however it will be recorded correctly without flashing.

7. After completing your title, press "**PAGE**" button and create the title on another page.

8. After creating the title, press "**TITLE**" button to remove the title graphics from the viewfinder. Now title graphics is stored in memory.

NOTE: As long as the correct current time can be displayed, the title is held in memory.

Correcting errors during title storage

1. Press "**Shift**" button repeatedly until the character to be corrected will flash.

2. Press either "-" or "+" button until the correct character appears.

NOTE: The correct character may flash, however it will be recorded correctly without flashing.

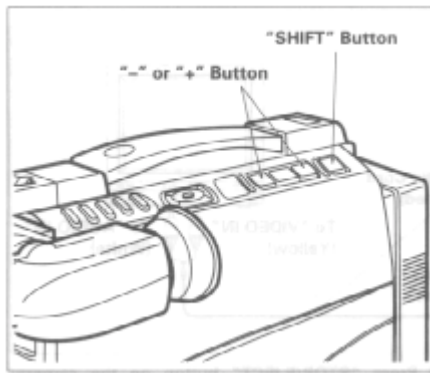

Recording titles on a tape in the camera/recorder

1. Slide **"POWER"** switch to **"VIDEO"**.
2. Locate the position on the tape that you wish to record the title.
3. Set **"POWER"** switch to **"CAM"**.
4. Press **"TITLE"** button to display the title graphics.
5. Press **"PAGE"** button until the title you wish to record appears in the viewfinder.
6. Press **"REC/PAUSE"** button to start the title recording.
7. Press **"TITLE"** button to remove the title graphics from the viewfinder. The camera/recorder will now record as normal.

NOTE: If you are planning to video tape an event you must prepare your titles in advance, then by pressing **"TITLE"** button superimpose the title over the scene as it's being recorded. You cannot go back and record titles over existing video without erasing the previously recorded material.

Recording titles on another VCR while playing a tape back with the camcorder

1. Connect the camera/recorder and VCR. (See page 31.)
2. Select the title you wish to record from page 1 or page 2. The last title selected will appear first. Press **"TITLE"** button to turn title off.
3. Set the VCR in the recording mode and camera/recorder in the playback mode.
4. Press **"TITLE"** button when you see the scene where you want to record the title.
5. Press **"TITLE"** button to erase the display from the viewfinder.

Chart of characters available in the titler

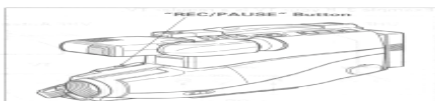

RECORDING TV PROGRAMS

If your TV or VCR has video/audio out jacks, you can record the TV program with camera/recorder.

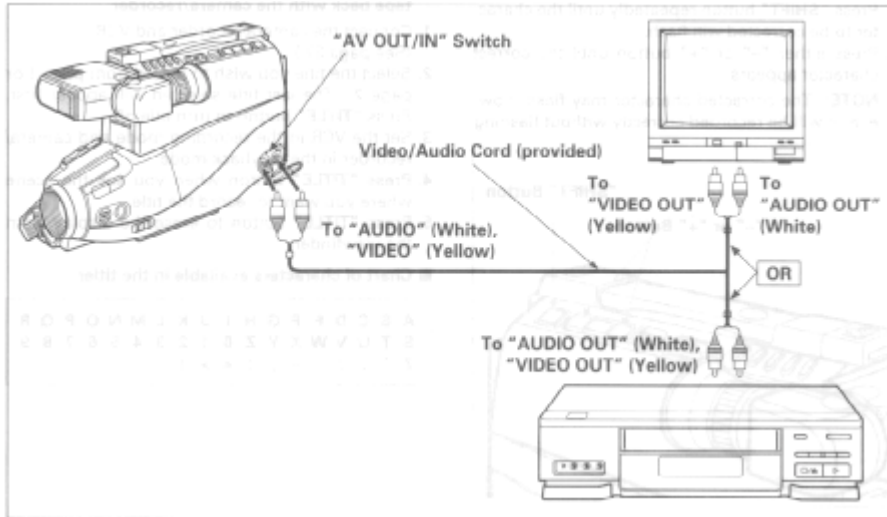

1. Connect the video/audio cord to **"AUDIO OUT"** and **"VIDEO OUT"** of your TV or VCR.
2. Connect the other end to **"AUDIO"** and **"VIDEO"** of camera/recorder.
3. Insert the cassette.

NOTE: Power source must be connected to the camera/recorder.

4. Set **"AV OUT/IN"** switch to **"IN"** position.
5. Press and hold the small button on **"POWER"** switch, and then slide it to **"CAM"** position. The **"POWER"** indicator will light.
6. Turn on your TV or VCR and tune it to the channel you wish to record.
7. Press **"REC/PAUSE"** button to start recording. You are now recording the TV program.
8. Press **"REC/PAUSE"** button to stop recording.
9. After recording, place **"POWER"** switch in **"OFF"** and then press **"STOP/EJECT"** button to remove the cassette.

RECORDING TV PROGRAMS

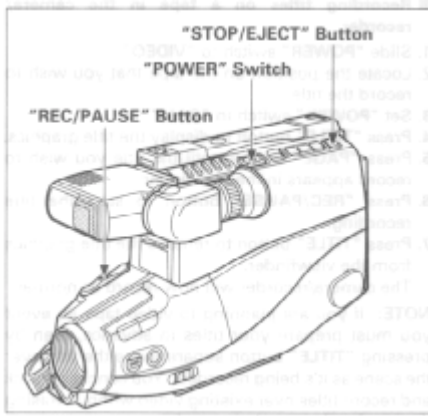

AUDIO DUBBING

The audio dubbing feature lets you record new audio (sound) on a previously recorded tape without erasing the original video.
When you audio dub a tape, the previous audio is erased and replaced with new sound.

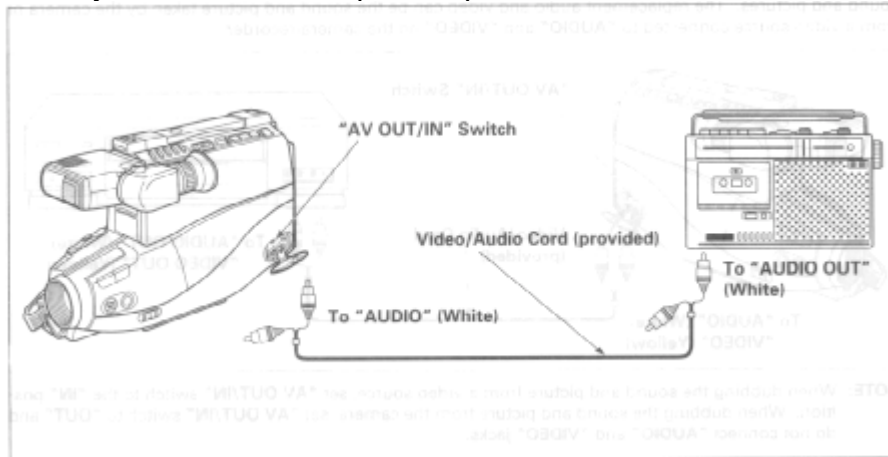
**NOTES:**

- Sound from the built-in microphone and the AUDIO jack can be dubbed.
- When dubbing audio from the built-in microphone, set **"AV OUT/IN"** switch to **"OUT"** and do not connect the **"AUDIO"** jack. When dubbing audio from the **"AUDIO"** jack, set the **"AV OUT/IN"** switch to **"IN"**.

1. Insert a recorded tape. Be sure that the record safety tab is not missing.
 2. Place **"POWER"** switch to **"VIDEO"** position.
 3. Play the tape and press **"REC/PAUSE"** button where you want to dub audio.
 - The camera/recorder enters the still play mode.
 4. Press **"DUBBING AUDIO/VIDEO"** and **"PLAY"** buttons at the same time.
 - **"A.DUB II"** appears in the viewfinder.
- NOTE:** If **"DUBBING AUDIO/VIDEO"** and **"PLAY"** buttons are pressed twice, audio and video dubbing will start. In this case, press **"STOP/EJECT"** button to release the dubbing mode.
5. Press **"RECORD/PAUSE"** button to start audio dubbing.
 6. Press **"STOP/EJECT"** button to stop audio dubbing.

NOTE: If counter memory **"M"** appears in the viewfinder, the tape stops automatically at the reading of **"0:00:00"** and audio dubbing stops.

AUDIO DUBBING

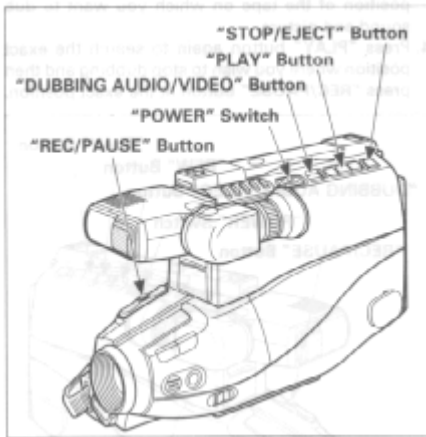

AUDIO AND VIDEO DUBBING

The audio and video dubbing feature lets you record new audio (sound) and video (pictures) simultaneously on a previously recorded tape. When you audio and video dub a tape, the previous audio and video are erased and replaced with the new sound and pictures. The replacement audio and video can be the sound and picture taken by the camera or from a video source connected to "**AUDIO**" and "**VIDEO**" jacks on the camera/recorder.

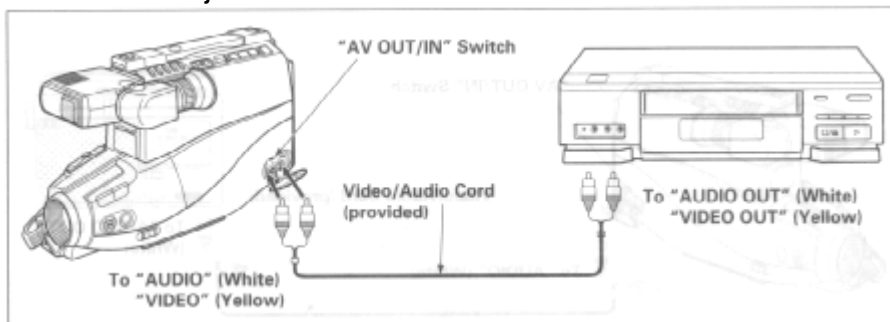

NOTE: When dubbing the sound and picture from a video source, set "**AV OUT/IN**" switch to "**IN**" position. When dubbing the sound and picture from the camera, set "**AV OUT/IN**" switch to "**OUT**" and do not connect "**AUDIO**" and "**VIDEO**" jacks.

1. Insert a recorded tape. Be sure that the record safety tab is not missing.
2. Place "**POWER**" switch in "**VIDEO**" position.
3. Press "**PLAY**" button and then "**REW**" or "**F.FWD**" button to search to the approximate position of the tape on which you want to dub sound and picture.
4. Press "**PLAY**" button again to search the exact position where you wish to stop dubbing and then press "**REC/PAUSE**" button at the exact position.

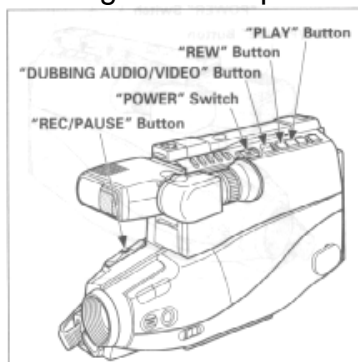

5. Press "**RESET**" button to set the counter reading to "**0:00:00**".
6. Press "**DISPLAY**" button so counter memory "**M**" appears.

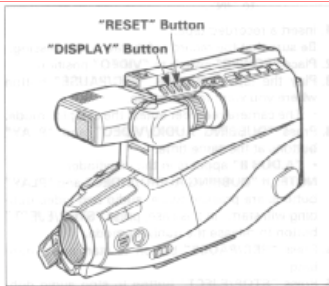

7. Press **"REW"** button to rewind the tape to the approximate position from which you want to start dubbing.
8. Press **"PLAY"** button, and when the exact position to start dubbing is reached, press **"REC/PAUSE"** button.
9. Press **"DUBBING AUDIO/VIDEO"** and **"PLAY"** buttons simultaneously twice. **"AV DUB II"** is displayed in the viewfinder, and at the same time the picture to be dubbed appears.

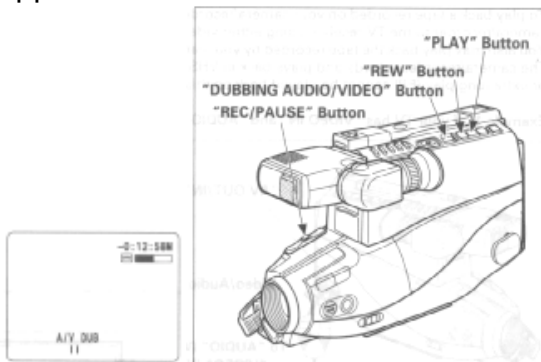

10. Press the **"REC/PAUSE"** button. Dubbing will start and will stop when the counter reads **"0:00:00"**.

AUTOMATIC REWIND

When the tape reaches its end during playback, it automatically rewinds to the beginning and stops.

VIEWING THE PICTURE PLAYED BACK ON YOUR TV

To play back a tape recorded on your camera/recorder and view it on your TV receiver, you must connect the camera/recorder to the TV receiver using either audio/video cord (not provided) or RF converter unit (optional).

You also may play back the tape recorded by your camera/recorder on any other VHS video cassette recorder. The camera/recorder records and plays back in VHS standard speed (SP). A tape recorded in long play (LP) or extra long play (EP) cannot be played back on this camcorder.

Example 1: If your TV has "VIDEO IN" and "AUDIO IN" jacks,

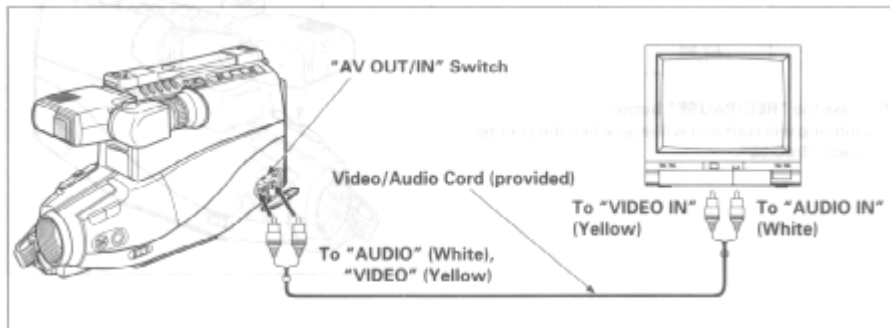

1. Connect the video/audio cord (provided) to "AUDIO IN" and "VIDEO IN" of your TV.
2. Connect the other end of the video/audio cord to "AUDIO" and "VIDEO" of your camera/recorder.
3. Turn on TV.
4. Set "AV OUT/IN" switch to "OUT" position.
5. Press "STOP/EJECT" button on the camera/recorder and then insert the cassette.
6. Place "POWER" switch in "VIDEO" position.
7. Press "PLAY" button.
8. After playing press "STOP/EJECT" button.

Example 2: If you have a VHS VCR,

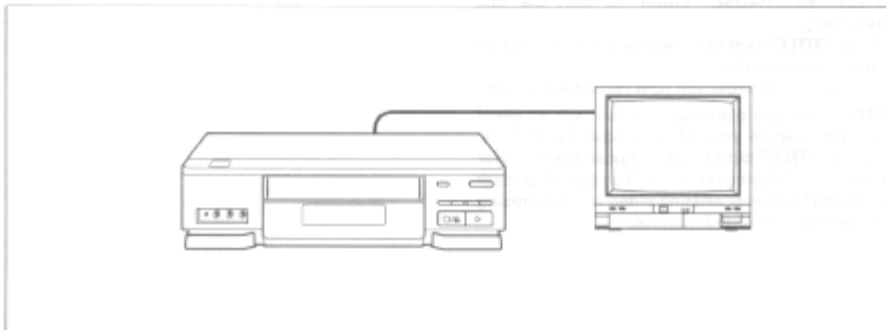

1. Insert the recorded tape into your VCR.
2. Press "PLAY" button of your VCR.

NOTE: When noise appears in the played back picture, adjust "**TRACKING**" control on the VCR so there is no noise.

Example 3: If your TV is a regular TV,

Diagram of Hookup

1. Disconnect the VHF antenna leads from the rear of the TV receiver.

NOTE: Leave the UHF antenna leads connected to the TV.

2. Connect the VHF antenna lead to "**IN FROM ANT**" on the RF converter unit. If the cable is round (75 Ohm), it will connect directly to the "**IN FROM ANT**". If it is the flat type, (300 Ohm), connect it to the antenna adaptor (300 Ohm to 75 Ohm) and slip the adaptor on to the "**IN FROM ANT**" terminal.
3. Connect the 75 Ohm coaxial cable with antenna adaptor to "**OUT TO TV**" on the RF converter unit.
4. Connect the other end to the VHF antenna terminal on the TV, as illustrated.
5. Connect the connector cable from RF converter unit to "**RF DC OUT**", "**AUDIO**", and "**VIDEO**" jacks on the camcorder.
6. Turn on the TV and set to channel 3 unless channel 3 is one of the TV stations in your area. If channel 3 is used in your area, set your TV to channel 4.
7. Set the RF channel selector on the RF converter unit to "**CH3**" or "**CH4**" to match the channel selector on your TV.
8. Perform same procedures in steps 4 through 8 of "**Example 1**".

NOTE: If you want to watch a TV program with camera/recorder connected as illustrated, slide "**POWER**" switch of the camera/recorder to "**OFF**".

STILL

When **"REC/PAUSE"** button is pressed during playback, a still picture can be seen. To start again press **"REC/PAUSE"** button and playback will be resumed.

NOTE: There will be some noise (interference) in the still picture.

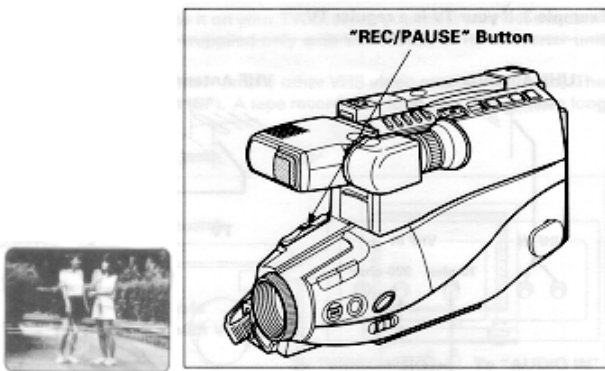

FORWARD AND REVERSE SEARCH

When you press "**F.FWD**" or "**REW**" button during playback, the tape will be played back at a speed about 3 times faster than normal playback speed, and you can easily locate a certain spot on the tape. Press "**PLAY**" button to return to normal playback mode or press "**STOP/EJECT**" button to stop tape movement.

NOTE: There will be some noise (interference) in the forward or reverse search pictures while visually scanning.

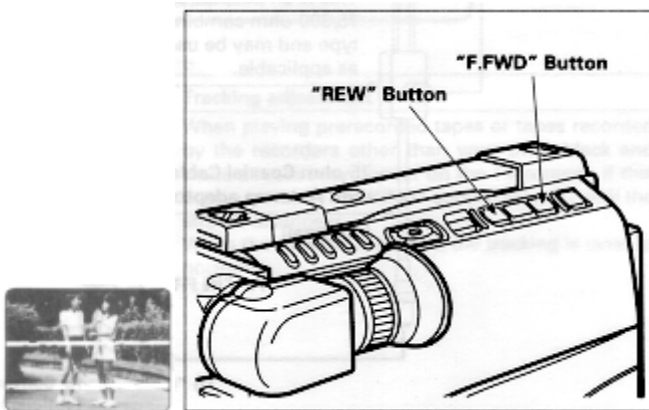

MEMORY

When the tape counter with memory indication appears in the viewfinder, a tape that is being rewound automatically stops when the counter reads approximately **"0:00:00"**. This is useful if there is a section of tape you want to review immediately after recording or if you want to return to the same point several times in a row.

1. Press **"DISPLAY"** button. (The indicator **"M"** appears beside the linear time counter.)
2. Start playing or recording a tape.
3. At the point you want playback to start, press **"RESET"** button to reset the counter to **"0:00:00M"**.
4. Continue to play back or record.
5. Press **"STOP/EJECT"** button.
6. Press **"REW"** button. The tape will be rewound to the preselected point, at approximately **"0:00:00M"** indication.

NOTE: The tape will also stop approximately at **"0:00:00M"** during fast forward mode.

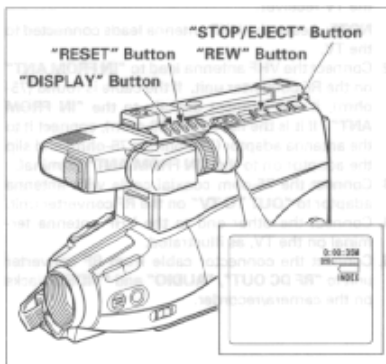

CAMERA/RECORDER TO VCR DUBBING

If you wish to exchange or copy some of your friend's favorite home recordings, the following instructions can be used to connect camera/recorder to VCR for this purpose.

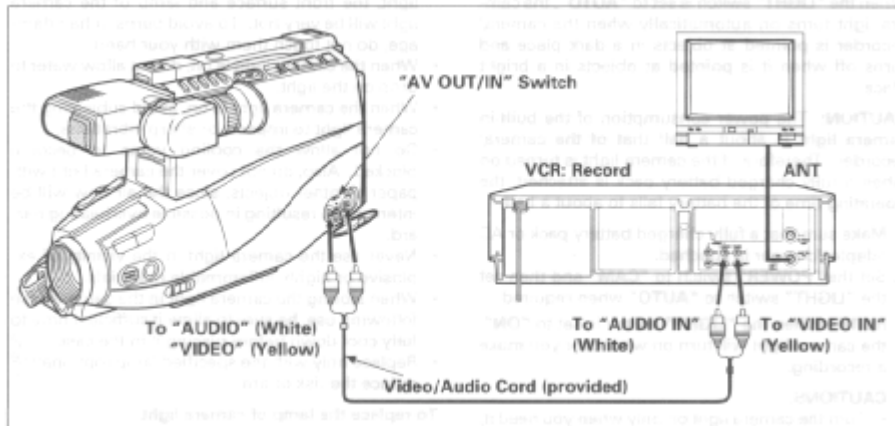

1. Connect the video/audio cord (provided) to "AUDIO" and "VIDEO" of your camera/recorder.
2. Connect the other ends to "AUDIO IN", "VIDEO IN" of your VCR as shown in the diagram above.
3. Set "AV OUT/IN" switch to "OUT" position.
4. Play the tape on the camera/recorder and record it on the VCR.

NOTE: If you connect the "VHF OUT TO TV" connector of VCR to the "TV ANT" connector, as illustrated and set "VCR/TV" selector of the VCR to "VCR" mode, the picture being dubbed by VCR can be monitored.

FLYING ERASE HEAD

A rotating erase head which eliminates glitches and rainbow noise that occurs at the joints between recorded segments.

USING THE BUILT-IN CAMERA LIGHT

Use the built-in camera light if you wish to shoot objects in dark places. When the "**LIGHT**" switch is set to "**AUTO**", the camera light turns on automatically when the camera/recorder is pointed at objects in a dark place and turns off when it is pointed at objects in a bright place.

CAUTION: The power consumption of the built-in camera light is about a half that of the camera/recorder. Therefore, if the camera light is turned on when a fully charged battery pack is attached, the operating time of the battery falls to about a half.

1. Make sure that a fully charged battery pack or AC adaptor/charger is attached.
2. Set the "**POWER**" switch to "**CAM**" and then set the "**LIGHT**" switch to "**AUTO**" when required.

NOTE: When the "**LIGHT**" switch is set on "**ON**", the camera light will turn on whenever you make a recording.

CAUTION:

- Turn the camera light on only when you need it, otherwise the operating time of the battery pack is shortened due to the power consumption of the camera light.
- When the "**LIGHT**" switch is set to "**AUTO**", the camera light does not turn on unless a cassette is loaded.

CAUTION: Do not hold the unit by the built-in camera light when carrying as this could cause a malfunction.

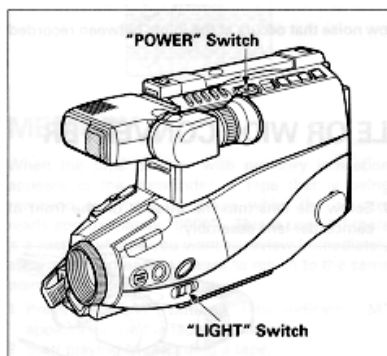

3. After use, set the "**LIGHT**" switch to "**OFF**" or set the "**POWER**" switch of the camera/recorder to "**OFF**" position.

CAUTION:

USING THE BUILT-IN CAMERA LIGHT

- During operation and/or after use of the camera light, the front surface and lamp of the camera light will be very hot. To avoid burns or hair damage, do not touch them with your hand.
- When the camera light is on, do not allow water to drop on the light.
- When the camera light is on, avoid subjecting the camera light to impacts or sharp vibrations.
- Do not allow the cooling vents to become blocked. Also, do not cover the camera light with paper or other objects, since the air flow will be interrupted, resulting in possible overheating hazard.
- Never use the camera light in the vicinity of explosive or highly inflammable materials.
- When storing the camera light in the camera case following use, be sure to allow it sufficient time to fully cool down before placing it in the case.
- Replace only with the specified lamp (optional) to reduce the risk of fire.

To replace the lamp of camera light

To remove the front case, press and hold the tab, then remove the front case.

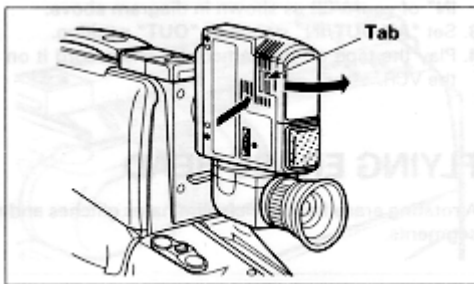

To replace the front case, pass the lamp through the hole of the reflection plate then attach the upper hooks to the camera light, and then attach the lower hook to the camera light.

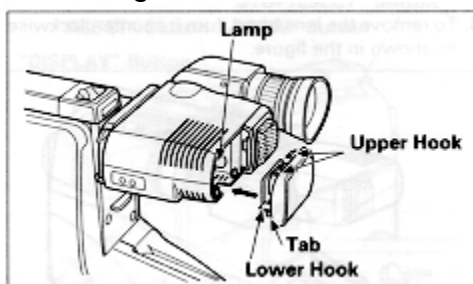

NOTES:

- Do not touch the lamp directly with your fingers. It may shorten its service life.
- When the lamp is replaced, or when the front case of the camera light is removed, make sure the front case is attached to the camera light properly.
- Consult your nearest service center to replace the lamp.

EYEPIECE ADJUSTMENT

To use the electronic viewfinder without eyeglasses on, adjust the diopter control for optimum focus adjustment.

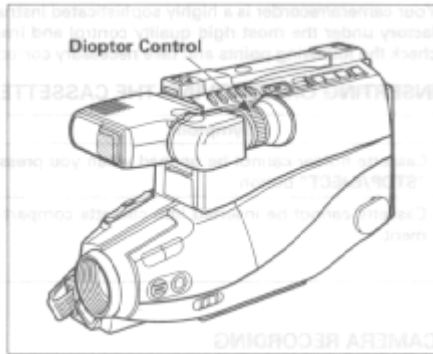

VIEWFINDER BRIGHT, COLOR AND TINT CONTROLS

You can adjust the viewfinder brightness, color and tint as required.

"**BRIGHT**" Control

Viewfinder brightness can be adjusted by turning the "**BRIGHT**" control. This does not affect the picture actually recorded by the camera/recorder.

"**COLOR**" and "**TINT**" Controls

The small "**COLOR**" and "**TINT**" controls are set at the factory and should require no adjustment. If they ever require adjustment, use a plastic screwdriver. Make the adjustments with caution to prevent damaging the miniature controls.

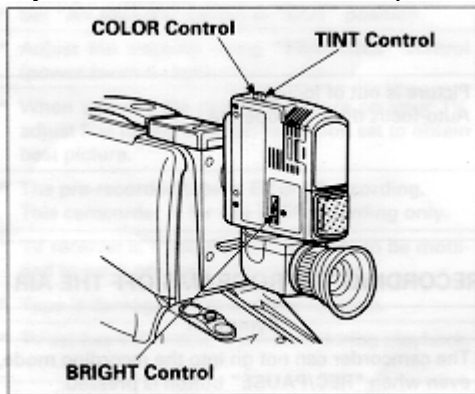

HOW TO ATTACH THE SHOULDER STRAP

Attach the shoulder strap (provided), as illustrated.

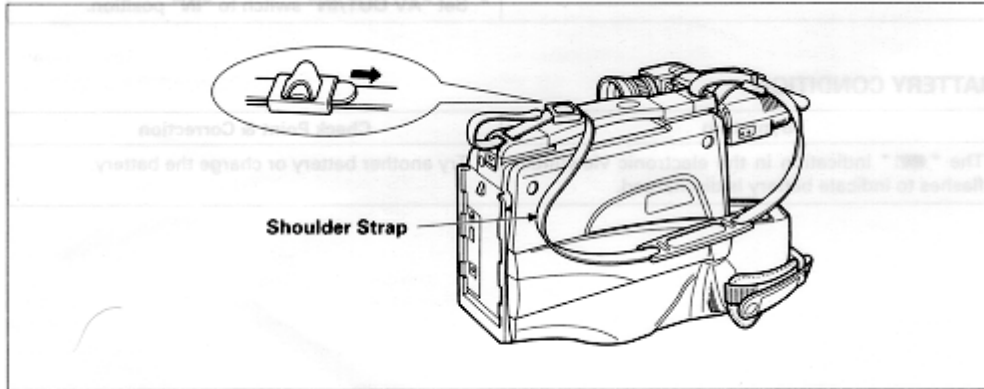

TROUBLESHOOTING

Your camera/recorder is a highly sophisticated instrument. It has been carefully checked and adjusted at the factory under the most rigid quality control and inspection systems. However, should problems develop, check the following points and take the necessary corrective measures.

INSERTING OR REMOVING THE CASSETTE

Symptom

Check Point & Correction

Cassette holder cannot be opened when you press "STOP/EJECT" button.

Connect the power source.

Cassette cannot be inserted into cassette compartment.

Load cassette in direction indicated by arrow on

cassette.

Cassette window must be

toward outside

CAMERA RECORDING

Symptom

Check Point & Correction

Picture does not appear in the viewfinder.

Remove the lens cap.

Set "POWER" switch to

"CAM" position.

The camera/recorder can not go into the recording mode, even when "REC/PAUSE" button is pressed.

The cassette has had the erase prevention tab removed.

Stick a piece of cellophane

tape over the erase prevention

hole or select a different

cassette.

Picture is out of focus.

Set "POWER" switch to

"CAM" position.

Auto-focus does not operate.

Make sure that "FOCUS"

does not appear in the

viewfinder. If displayed,

press FOCUS control

(AUTO/MAN) buttons to

erase it.

Auto-focus does not operate if the wide angle or

telephoto lens is attached.

RECORDING TV PROGRAMS OFF THE AIR

Symptom

The camera/recorder can not go into the recording mode, even when "REC/PAUSE" button is pressed.

Check Point & Correction

The cassette has had the erase prevention tab removed.
Stick a piece of cellophane tape over the erase prevention hole or select a different cassette.
Set "POWER" switch to "CAM" position.
Connect the camera/recorder and TV (or VCR).
Set "AV OUT/IN" switch to "IN" position.

BATTERY CONDITION

Symptom

The "■" indication in the electronic viewfinder indicate battery is discharged.

Check Point & Correction

Try another battery or charge the battery.

NO OPERATION IS ACCEPTED

Symptom

Power is turned on, but no button operations are accepted.

Check Point & Correction

Remove the power source, and after about one minute, push the reset switch gently using a toothpick, etc. until you feel a click. Since this erases the date, time and other customer preferred features, reset them again.

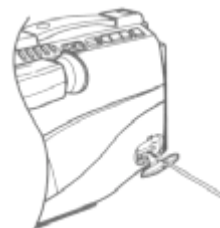

PLAYBACK OF PRE-RECORDED CASSETTE

Symptom

Check Point & Correction

"PLAY" button cannot be engaged.

Set the "POWER" switch to "VIDEO" position.

No picture appears on television screen when "PLAY" is pressed.

Set the television to the "PLAY" is camera/recorder channel

(3 or 4) depending upon the selected channel on RF

channel select switch..

(TV is connected to the camera/recorder by using RF of converter unit.)

Interference on playback picture.

Adjust the tracking using "TRACKING" control (power zoom switch).

When you see the playback picture on your TV, adjust fine tuning knob on television set to obtain best picture.

The pre-recorded tape is EP or LP recording.

This camera/recorder is for use in SP recording only.

Picture bends at the top of the TV screen.

TV receiver is older type. It needs to be modified to work properly with camera/recorder.

Tape is damaged. Try another cassette.

Color of your TV screen is too bright, too faint or change.

TV set has VIR circuit. Turn off during playback.

CLEANING THE INSIDE OF THE ELECTRONIC VIEWFINDER

If dust or foreign matter adheres inside the viewfinder, clean it by using the following procedure.

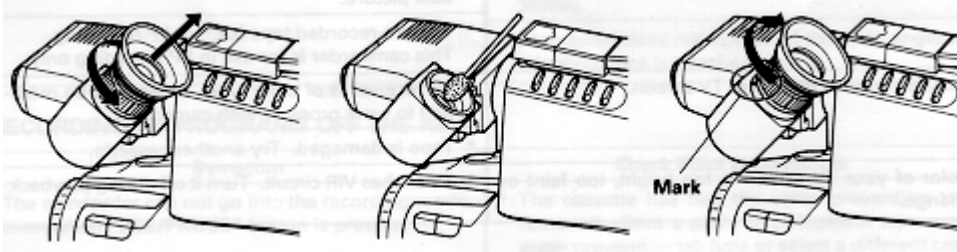

TROUBLESHOOTING

1. Rotate and remove eye cup.
2. Clean the picture tube face and lens. To prevent scratching, use a soft non abrasive cloth, swab or lens cleaning paper.
3. Align the reference mark and rotate the eye cup in the direction of arrow.

HEAD CLEANING

- Picture playback may become blurred or be interrupted. This does not mean that the recorded program has been erased.
- Dirt accumulated on the head after long periods of use causes this problem. In this case, head cleaning requiring highly technical care is necessary.
- Consult your nearest dealer or VCR service center before using a head cleaning tape.



PERIODIC MAINTENANCE

The video camera/recorder is a precision electromechanical device which will require periodic maintenance after a period of normal use. We expect that no maintenance other than head cleaning will be required during the warranty period of most users, unless the video camera/recorder is heavily used or seldom used. Normal maintenance is the responsibility of the user, although defective parts are covered during the warranty period. Consult your VCR service center to determine recommendations for normal maintenance based upon your location, use patterns and machine age.

SPECIFICATIONS

General

Power requirements	9.6V DC
Power consumption	8 watts (nominal)
Dimensions:	4-3/8"(W) x 8-1/16" (H) x 12-1/4" (D) 111(W) x 205(H) x 311(D) mm
Weight	4.4 lbs (2.0 kg)

Video Recorder Section

Format	VHS
Record/playback system	Two video record/playback heads plus a flying erase head
Video signal	EIA standard NTSC color
Tape speed	33.35 mm/sec.
Video input	1.0 Vp-p, 75 ohm
Video output	1.0 Vp-p, 75 ohm
Audio input	-7.8 dBs (316 mVrms), more than 47 kohm
Audio output	-7.8 dBs (316 mVrms), less than 1 kohm
Fast forward/rewind time	Less than 6 minutes with T-120 cassette

Camera Section

Scanning	525 lines/ 60 fields/ 30 frames
Required minimum illumination	1 lux
Pickup device	1/3" CCD
Lens diameter	46 mm

HOTLINE

For U.S.A. only

HITACHI

Service Hotline

To locate an authorized
HITACHI service facility
in the continental U.S.A.

DIAL TOLL FREE

7 days a week, 24 hours a day

800 HITACHI

1-800-448-2244

Hitachi Home Electronics (America), Inc.

Hitachi has made every effort to assure you hours of trouble free operation from your unit. However, should you require service, a network of Hitachi Authorized Service Facilities has been established in all 50 states and Puerto Rico. Each facility will provide you with convenient and expedient assistance. Our service "Hotline" operator will direct you to the Hitachi Authorized Service Facility nearest you. Just present proof of purchase and/or delivery receipts to the Hitachi Authorized Service Facility and service will be rendered in accordance with the terms of the limited warranty as stated on your warranty card or operating guide.

Should you have any questions regarding in-warranty service, operation or technical assistance, please contact:

Hitachi Home Electronics (America), Inc.

3890 Steve Reynolds Blvd

Norcross, GA 30093

Tel 404-279-5600

Hitachi Sales Corporation of Hawaii

3219 Koapaka St./Honolulu, HI 96819

Tel 808-836-3621

ACCESSORY TO ADD MORE EXCITEMENT

You're ready to add more excitement to your home videos, and Hitachi's right there with you. With our new line of video accessories, you can go anywhere your imagination takes you.

Now that you know how much fun video recording can be, you'll want to add new dimensions to your home videos. With convertor lenses, adaptors, extra.

We are preparing two kinds of accessory.

1. Included accessory

See page 3.

2. Optional accessory

Chart of Accessories

* Consult your nearest service center to replace the lamp.

If you want to place an order for these items, you can:

1. Call the toll-free number "1-800-HITACHI".
 2. Mail to HITACHI with attached form: see page 47.
-

HOW TO ORDER USA only

In Canada - Please use Canadian order form in French version of this manual - page 47.

BY PHONE

To place your order by phone, have your VISA, MASTER CARD, or AMERICAN EXPRESS card ready and call this toll-free number anytime 24 hrs/day, 7 day a week.

1-800-HITACHI

BY MAIL

To place your order by mail, detach and mail the completed order form with credit card information, money order, or check in U.S. currency (payable to HITACHI HOME ELECTRONICS (AMERICA) INC.) to the following address:

**HITACHI HOME ELECTRONICS (AMERICA) INC.
PARTS DIVISION
401 WEST ARTESIA BLVD.
COMPTON, CA 90220**

Order Form

¹Introduced in the 94-95 line. Mention as current model!

Warranty: 90 days labor, 1 year parts.

VM3700A: 12x1 optical zoom, 24x1 digital zoom, 1 lux, 46 mm lens diameter, 270k pixels, color viewfinder.

Shutter Speeds: 60, 100, 120, 180, 250, 350, 750, 1000, 1500, 2000, 4000 of a second.

Uses TTL (Through The Lens) focusing system.