

Canon VC-200

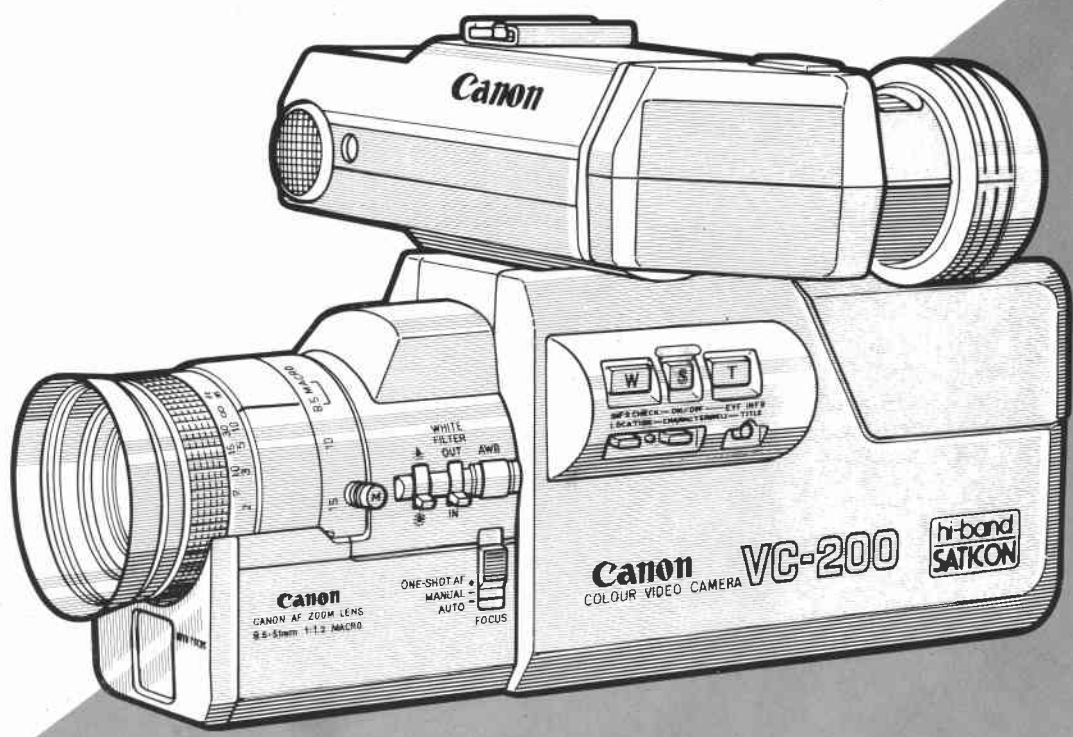

E Instructions

D Bedienungsanleitung

F Mode d'emploi

Canon Color Video Camera VC-200

Thank you for purchasing the Canon Color Video Camera VC-200. For the fullest understanding and enjoyment of your video system, please read this instruction book with the camera at hand before setting out to record.

This instruction book provides the operating instructions for the VC-200 camera when used in conjunction with the Canon Portable Video Recorder VR-30. For recorder operations, please refer to the recorder's instruction manual.

The VC-200 is designed for use in countries under the PAL standard.

WARNING: TO PREVENT DAMAGE TO THE PICK-UP TUBE, DO NOT AIM THE LENS DIRECTLY AT THE SUN OR BRIGHT LIGHTS, EVEN WHEN THE POWER IS OFF.

CAUTION: TO PREVENT FIRE OR SHOCK HAZARD AND ANNOYING INTERFERENCE, USE THE RECOMMENDED ACCESSORIES ONLY.

WARNING: TO PREVENT FIRE OR SHOCK HAZARD, DO NOT EXPOSE THIS EQUIPMENT TO RAIN OR MOISTURE.

Canon

VC-200

CONTENTS

Precautions	4	Recording (and Playback) Procedures	18
Nomenclature and Functions	6	Other Operations	19
Adjusting the Electronic Viewfinder	8	Recording a Backlit Subject	19
Connecting the Camera to the Recorder	9	Using the Macro Mechanism	20
Power Sources	10	Using the Standby/Operate Switch	21
External Power Sources	10	Using an External Microphone	21
Internal Power Source	11	Viewfinder Display System	22
Recorder Preparations	12	EVF Information Mode	23
Basic Steps for Camera Recording	12	Information Check Display	26
Detailed Operating Procedures	13	Title Mode	26
Adjusting White Balance	14	Stopwatch Mode	29
Checking the Exposure	15	Optional Accessories	30
Selecting the Focusing Mode	15	Troubleshooting	32
Subjects Not Suited for the Autofocus System	16	Specifications	34
Focusing Subjects which Require Special Attention	16	Canon Color Video Camera VC-200 System	35
Using the Zoom Mechanism	17		

Precautions

1) Never disassemble the camera.

Taking the camera apart can result in injury to you, or can damage the camera. If the camera is not working properly, contact your nearest Canon service facility.



2) No water please.

Do not use the camera in the rain, or operate it after water has been splashed on it. If water does enter the camera, DO NOT turn it on. Contact your nearest Canon service facility immediately.



3) Check for visible malfunctions.

If the camera smells unusual or starts smoking during operation, turn the recorder VTR switch off, disconnect the camera cable, and contact your nearest Canon service facility.



4) Avoid heat radiating sources.

When using artificial lighting, be particularly careful not to expose the camera to too much heat.

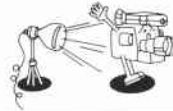

5) Follow battery pack instructions.

When using the Canon Battery Pack, be careful to observe the instructions listed for that unit in the recorder's manual.

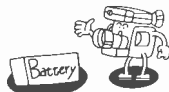

6) Handle the camera gently.

Banging the camera around or subjecting it to severe shocks and vibrations can damage it.



7) Cap the lens after use.

Make it a habit to replace the lens cap immediately after using the camera to protect the lens from sand and dust particles.

Be particularly careful on windy days.



8) Shield the camera from bright light sources.

Do not point the camera toward the sun or any other strong light source under any circumstances. This can damage the camera tube.



9) Avoid high temperatures and humidity.

Do not expose the camera to high temperatures or high humidity. Note that the heat inside of a closed car during hot weather is far higher than the camera can withstand.



10) Avoid extreme temperature changes.

Bringing the camera from a cold place into a warm place will cause condensation to form on the internal parts and lens, and should be avoided when possible.

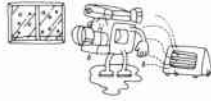

11) Clean the camera occasionally.

The camera should be cleaned using a soft, dry cloth. Avoid the use of chemically treated rags or volatile solvents (such as thinner) for cleaning purposes.



12) Turn power OFF after use.

After using the camera, always turn OFF the VTR switch on the recorder to prevent unnecessary battery drain.



13) Store the camera in the proper location.

If you do not intend to use the camera over a long period of time, store it in a safe, dust-free location where humidity is low, and where the ambient temperature will not rise above 30°C.



14) Check all camera functions before use.

If you have not used the camera for a long period of time, and you plan to make some important tapes, check all camera functions to make sure they are working properly.



15) No electromagnetic force fields.

Avoid using the camera near electromagnetic forces (such as electric motors, audio components, and speakers), which may cause picture distortion or noise.



16) Clean the lens carefully.

To clean the lens surface, use only a blower brush, cleaning fluid and tissue made specially for cleaning video or camera lenses.

First remove dust with the blower brush. Then moisten the lens tissue with one or two drops of lens-cleaning fluid and gently wipe the lens, starting at the center and moving toward the outer edges in a circular motion.

Nomenclature and Functions

For details, refer to the indicated pages.

Electronic Viewfinder

A monochrome electronic viewfinder (EVF). Recording data, a title or stopwatch reading can be displayed inside the viewfinder. The recorded picture can also be played back in the viewfinder. (p. 8)

Tally Lamp

Blinks while recording is in progress. (p. 18)

Microphone

For recording live sound during shooting.

Auto White Balance Button (AWB)

Press this button while pointing the camera at a white object to automatically adjust white balance. (pp. 14, 24)

Lens Hood

Used to prevent stray light from entering the lens. Remove by turning counterclockwise before attaching a filter or the optional Canon Tele-converter 1.4X 46. (p. 30)

Zooming Lever / Macro Mode Lever (Wide/Macro)

Used to manually zoom the lens. Also used to focus the lens in the macro mode. (pp. 17, 20)

Filter Selector (☀/☁/☂)

Used to select the proper color correction filter according to the lighting conditions. (pp. 13, 25)

White Filter Switch (IN/OUT)

When no white object is available for automatic white balance adjustment, set this switch to IN and then press the AWB button to adjust white balance. (p. 14)

Accessory Shoe

Used to mount the Canon Super-directional Microphone DM-100 or other optional accessories. (p. 31)

Dioptric Adjustment Ring

Used to adjust the eyepiece to your individual eyesight. (p. 13)

Control Panel

Used to display recording information, title, and stopwatch in the viewfinder. Also used to operate power zoom. (p. 22)

Polarity Inverter Switch

Reverses the polarity of the start button. Normally left in the + position.

Focus Selector (AUTO/MANUAL/ ONE-SHOT AF)

Used to select automatic or manual focusing. One-shot autofocus is also possible. (pp. 15, 16, 25)

Power Zoom Speed Button

Used to select the speed (high or low) at which the lens is zoomed. (pp. 17, 25)

Display Button (A) (INFO CHECK, LOCATION, START/STOP)

Used to check recording information and to select the character location. Also serves as the start/stop button for the stopwatch. (p. 26)

Power Zoom Switches (T/W)

Used to activate the power zoom mechanism. (p. 17)

Mode Select Button (EVF INFO, TITLE, STOPWATCH)

Used to select the EVF information mode, title mode, or stopwatch mode. (p. 26)

Display Button (B) (ON/OFF, CHARACTER [DEL], RESET)

Serves as the on/off button for the electronic viewfinder (EVF) information display, selects the title characters (in pause mode), deletes titles (in record mode), and resets the stopwatch. (p. 26)

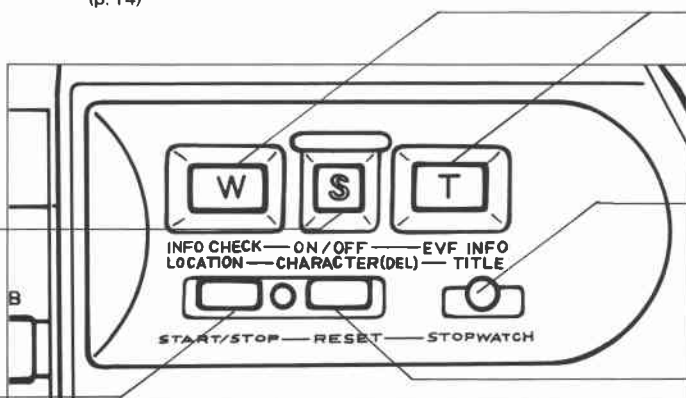
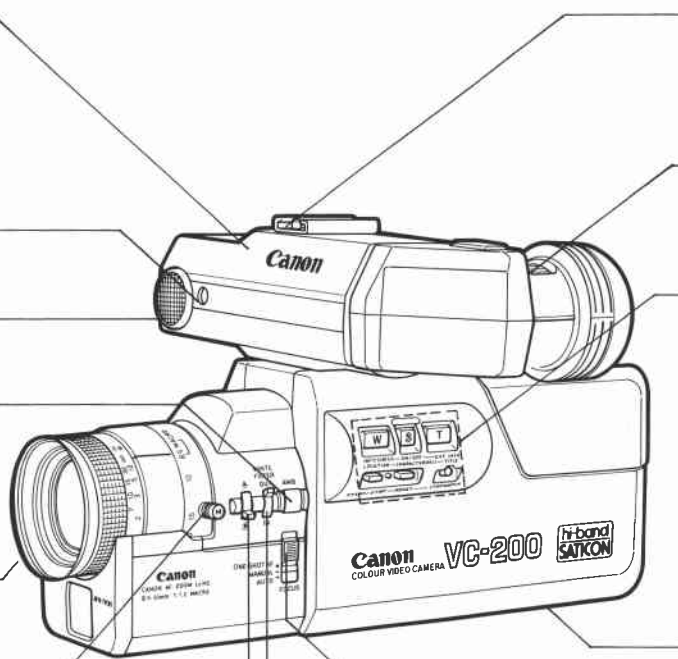

Control Panel

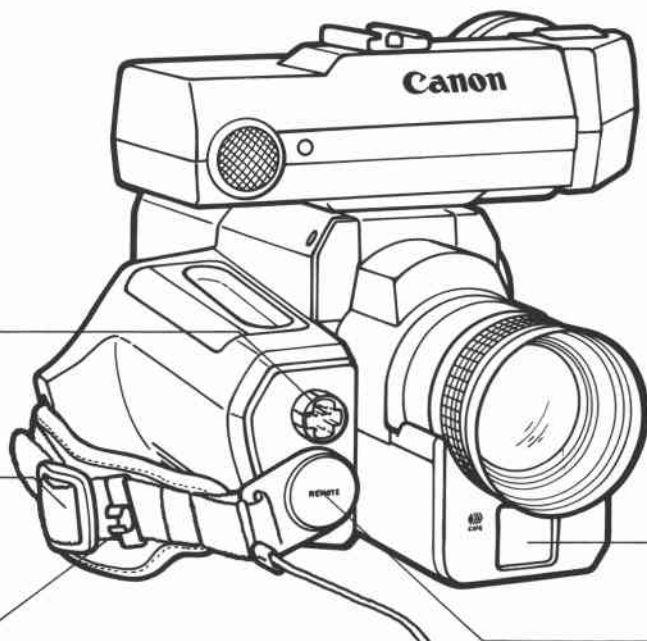

Camera Connector
Used for connecting the camera cable. (p. 9)

Hand Strap
The strap length can be adjusted for comfortable handling.

Cable Clamp
Used to hold the camera cable in a convenient position. (pp. 9, 15)

Autofocus Window
Receives the light for autofocus operation. (p. 15)

Zoom Remote Control Socket (REMOTE)
For connecting the optional Canon Zoom Remote Control Unit ZR-20. Recording start/stop and zooming operations are possible from a distance of up to 6 meters. (p. 30)

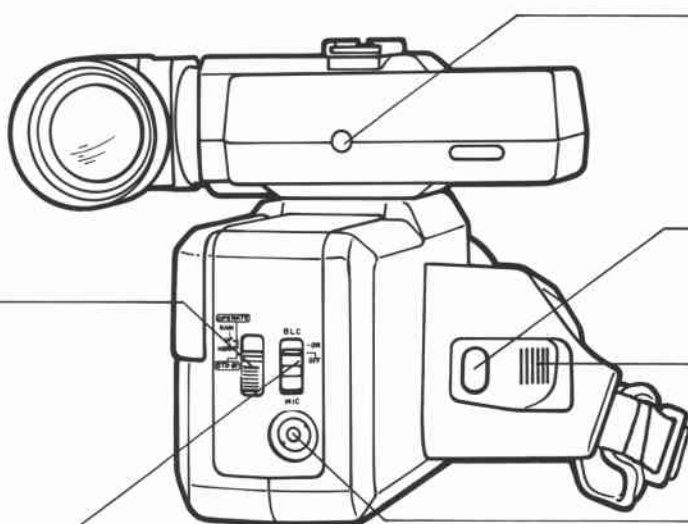

Standby/Operate Switch (UP/NORM, STD-BY)
Used to place the camera in standby mode to conserve power during long pauses in recording. Also used to select the sensitivity according to the light level. (pp. 13, 15, 21, 24)

Backlight Compensation Switch (OFF/ON)
Set to ON to make an exposure correction when shooting a backlit subject. (pp. 19, 24)

Tally Lamp
Blinks while recording is in progress. (p. 18)

Start/Stop Button
Press to start or stop recording. (p. 18)

Thumb Rest
Place your thumb on this rest in order to hold the camera steady.

External Microphone Jack
Used to connect an external microphone, such as the optional Canon Super-directional Microphone DM-100 (the built-in microphone will be overridden). (p. 31)

Adjusting the Electronic Viewfinder

1

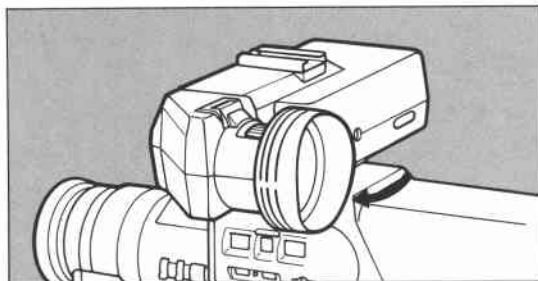

The electronic viewfinder is already attached to the camera. Rotate the viewfinder to the operating position as shown.

2

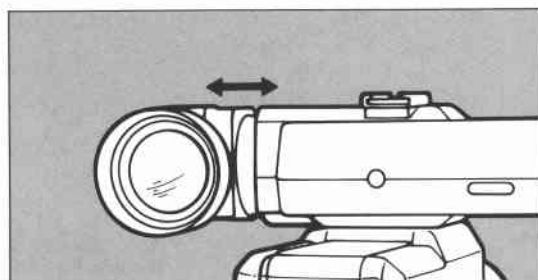

The viewfinder eyepiece can be extended approximately 10 mm to the left. Use it in the most convenient position.

3

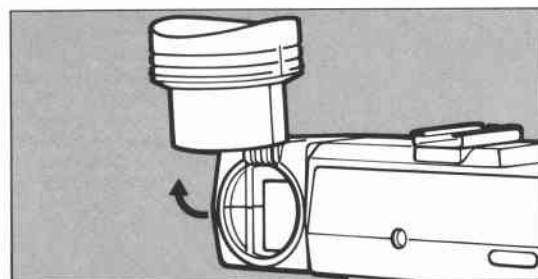

The eyecup portion of the eyepiece is hinged. Open it when you do not need to use the eyecup.

4

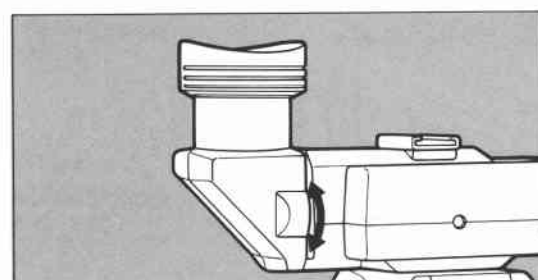

The viewfinder eyepiece can be rotated up and down.

Important: DO NOT allow direct sunlight to enter the viewfinder eyepiece or the inside of the viewfinder may be damaged.

5

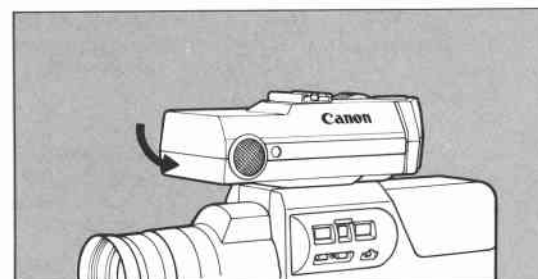

Turn the viewfinder 90° counterclockwise as shown to store the camera in the VC-200 camera's optional carrying case.

Connecting the Camera to the Recorder

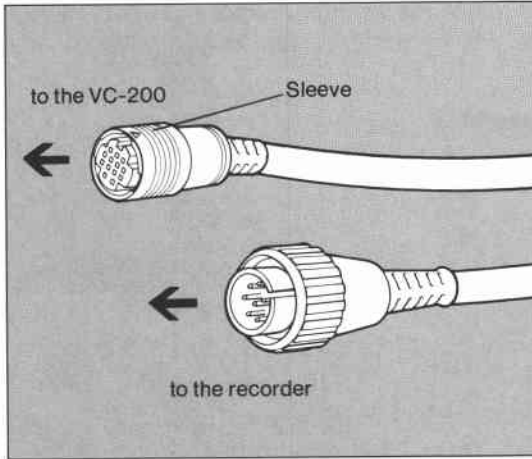

Camera Cable for VC-200

Important: DO NOT turn on the recorder VTR switch until all connections have been completed. The supplied camera cable is for exclusive use with the VC-200 camera; do not use it with other cameras. Also, do not use any camera cable other than that supplied with the VC-200.

1

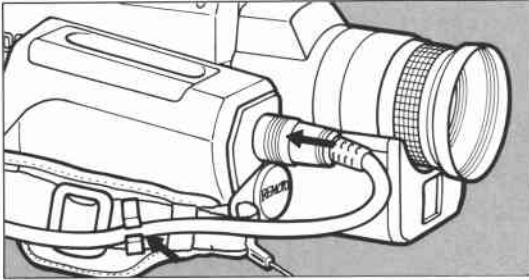

With the ► mark up, push the smaller plug on the camera cable (supplied with the camera) into the camera connector on the front of the VC-200 camera grip until it snaps in place. (Do not hold the cable by the sleeve while pushing it in place.) Then attach the camera cable to the cable clamp to hold the cable in a convenient position.

- To disconnect the cable, pull the plug while pulling back the sleeve.

2

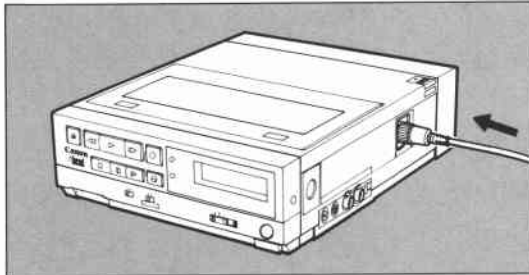

Make sure the recorder's VTR switch is OFF. The other (larger) end of the camera cable has a cut-out for proper alignment; for connection, it should be facing up. Plug the cable into the recorder's camera connector, then secure it by tightening the outer coupling ring.

Note: For greater mobility, the camera cable can be lengthened 6 meters using the optional Canon Extension Cord C-10R.

Power Sources

Power to the camera is supplied from the recorder. Three different sources are available for powering the recorder: two external power sources (a 220/240, 50 Hz mains outlet; or a 12 V DC car battery) and one internal source (a battery pack).

All power sources shown are sold separately from the recorder.

External Power Sources

AC Outlet

We recommend using one of the following external power sources when recording indoors or at locations where an AC outlet is available.

1. Using the Canon Compact Power Adapter CA-30 as the power source.

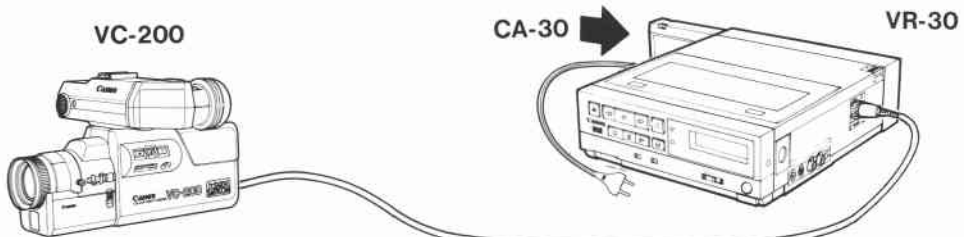

2. Using the Canon Tuner-Timer Unit VT-30 as the power source.

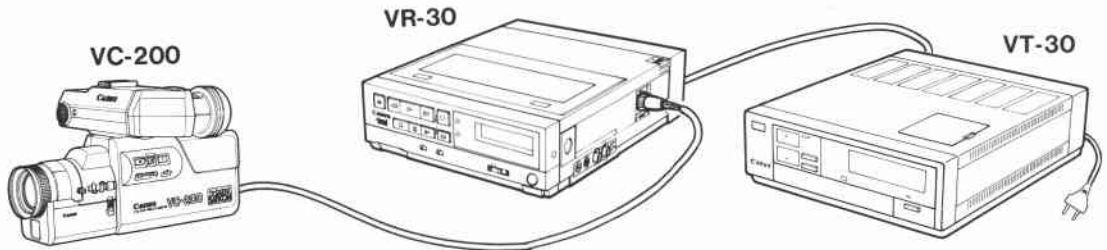

3. Using the Canon Power Adapter VP-30 as the power source.

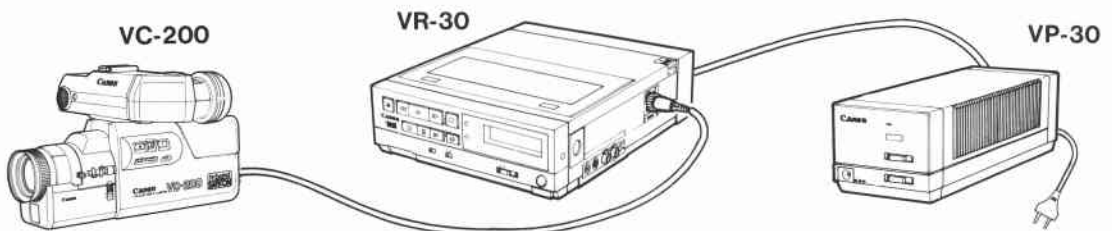

Car Battery

Using a car battery as the power source with the Canon Car Battery Cord C-202.

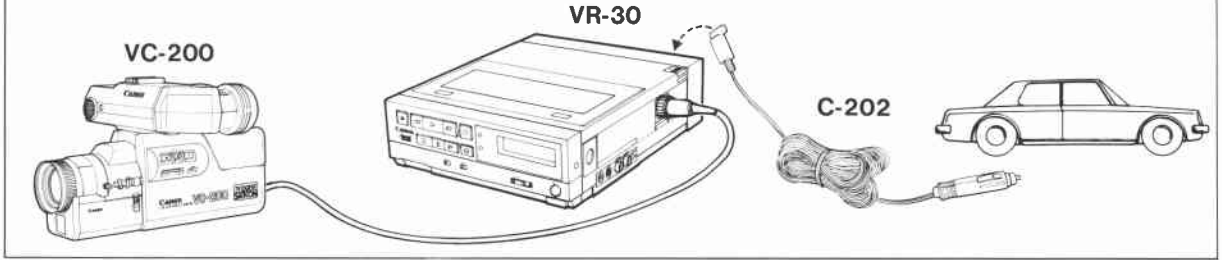

Important: Use the car battery cord only with 12 V batteries with negative grounds.

Internal Power Source

Battery Pack

The rechargeable Battery Pack BP-31 or BP-32 is recommended for recording which requires a great deal of mobility. The battery pack loads directly into the recorder for powering the system. For details on recharging the battery pack, see the power source instruction manual.

When the battery charge is nearly exhausted, the word "BATTERY" will blink in warning in the viewfinder. In this case, check the recorder's battery level indicator. If it indicates the battery is exhausted, recharge the battery pack or replace it with a fresh one.

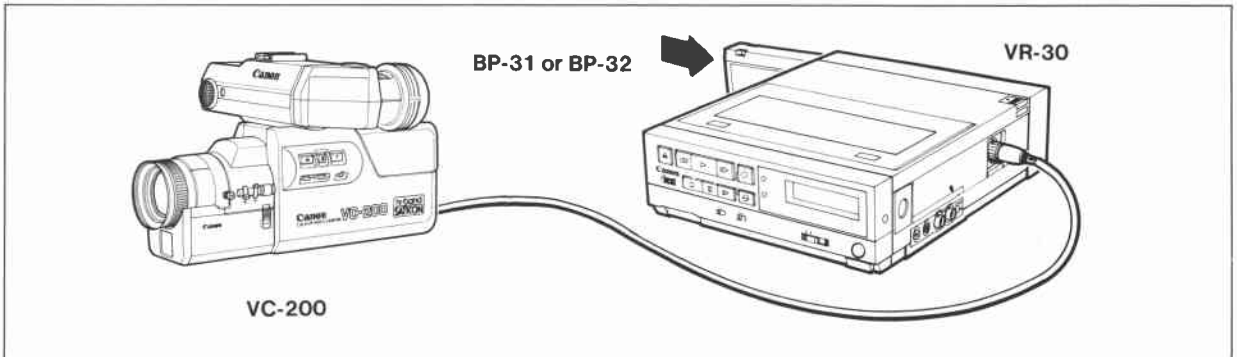

Recorder Preparations

- 1** Set the recorder's VTR switch to ON.
- 2** The recorder's control selector can be set to either the CAMERA or VTR position.

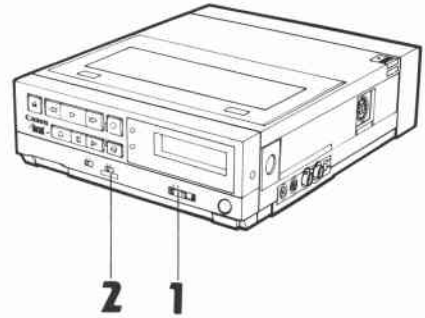

Basic Steps for Camera Recording

Connect the VC-200 camera, the recorder, and the power source, then follow the steps below. (For details, please refer to pp. 13—17.)

- 1** Prepare the **electronic viewfinder** for use.
- 2** Set the **standby/operate switch** to NORM.
- 3** Adjust the eyepiece to your eyesight using the **dioptric adjustment ring**.
- 4** Check the recorder's **battery level indicator** if "BATTERY" is blinking in the viewfinder.
- 5** Set the **filter selector** according to the light source.
- 6** Adjust **white balance**.
- 7** Check the **exposure indicator's** position for proper exposure.
- 8** Set the **focus selector** to AUTO or MANUAL.
- 9** Select the zoom speed using the **power zoom speed button** and push the **power zoom switch**.

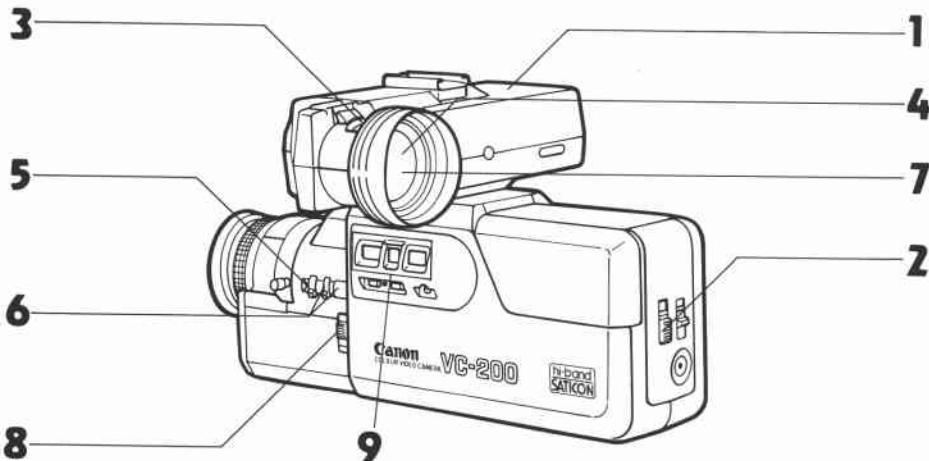

Detailed Operating Procedures

For details on the various viewfinder displays, please refer to pp. 24, 25.

1

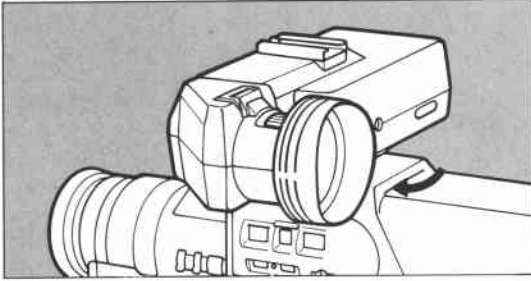

Adjust the electronic viewfinder for comfortable viewing.

2

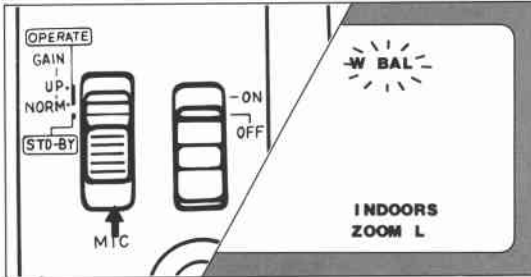

Remove the camera's lens cap. Set the camera's standby/operate switch to NORM. Three indicators will appear in the viewfinder as shown. (If the indicators do not appear, press the mode select button until they do.)

- Set the camera's standby/operate switch to STD-BY during pauses in recording to conserve power (see p. 21). The picture will not be displayed while in the standby mode.

3

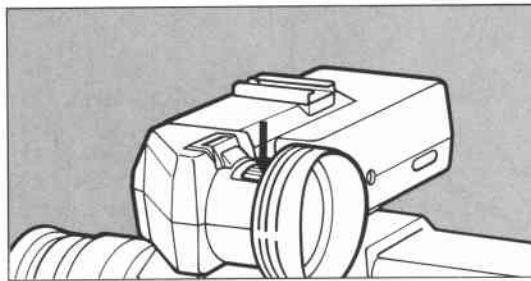

To ensure proper focus, you can adjust the eyepiece to your own eyesight with the dioptic adjustment ring. To adjust, turn the dioptic adjustment ring while looking in the viewfinder until the characters in the display are sharp.

- Eyeglass wearers should remove their glasses before adjusting the eyepiece.

4

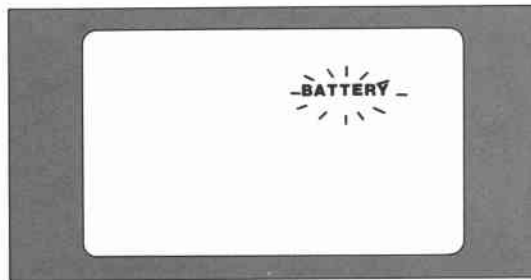

If the word "BATTERY" blinks in the viewfinder, the battery charge is nearly exhausted. Check the recorder's battery level indicator, and if it indicates the battery is exhausted, recharge the battery pack or replace it with a fresh one.

5

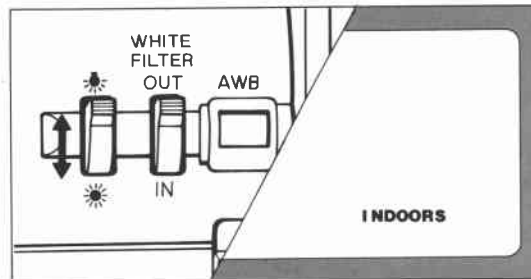

Set the filter selector on the camera to the sun mark (☀) for shooting in daylight. Set it to the tungsten lamp mark (💡) for shooting under artificial light. "OUTDOORS" or "INDOORS" will appear in the viewfinder accordingly.

6 Adjusting White Balance

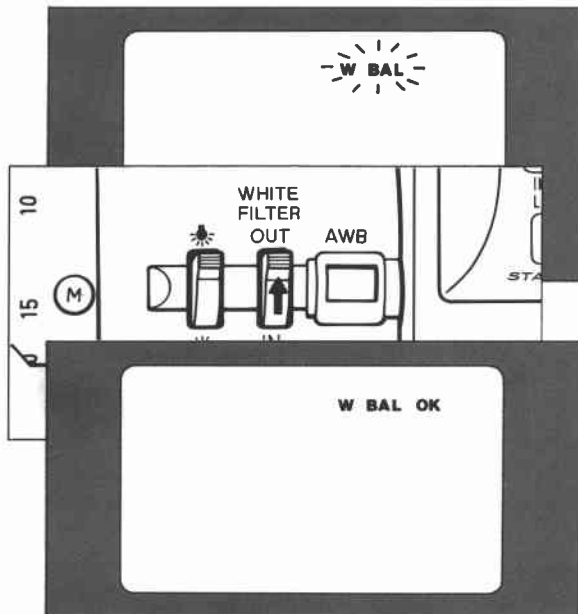

In order to obtain proper color balance, it is necessary to adjust white balance.

When a white object is available . . .

- 1 After setting the standby/operate switch to NORM, allow the camera to warm up for at least 20 seconds before adjusting white balance. (If "W BAL" is not displayed in the viewfinder, press the mode select button until it appears.)
- 2 Set the white filter switch to OUT.
- 3 Make sure the backlight compensation switch is set to OFF.
- 4 Point the camera at a white piece of paper or other white object (never at a light source) so that the object fills the screen.
- 5 Press the auto white balance (AWB) button until the blinking "W BAL" changes to "W BAL OK."
- 6 As soon as white balance is adjusted, "W BAL OK" disappears.

When no white object is available . . .

- 1 Set the white filter switch to the IN position (the picture will not be visible in the viewfinder).
- 2 Turn the zooming lever to the wide-angle setting.
- 3 Press the auto white balance button until "W BAL OK" appears in the viewfinder.
- 4 "W BAL OK" disappears when white balance is adjusted.
- 5 Return the white filter switch to OUT.

Notes:

- For optimum color quality, it is recommended to adjust white balance using a white object instead of the built-in white filter.
- Each time the lighting condition changes, read just white balance. In this case, press the mode select button until "W BAL" blinks in the viewfinder, then adjust white balance as described above.
- White balance is retained even when the camera is in the standby mode.
- If there is not enough light to adjust white balance (if "W BAL OK" does not appear, and "W BAL" continues to blink), use additional lighting for best results.

7 Checking the Exposure

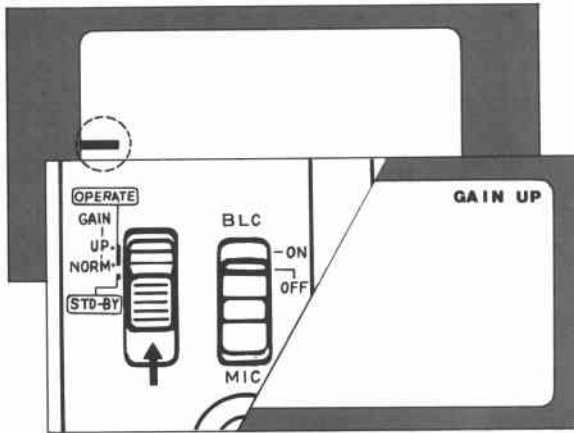

The iris is controlled automatically. Make sure the exposure indicator does not point to an extremely high or low position. If the indicator points to an extremely high position, use an ND (neutral density) filter. If it points to an extremely low position, first use additional lighting so that the indicator moves closer to the center. If the indicator continues to point to a low position, set the standby/operate switch to UP; "GAIN UP" will appear in the viewfinder.

- Picture quality will be somewhat lower with the switch set to UP.

8 Selecting the Focusing Mode

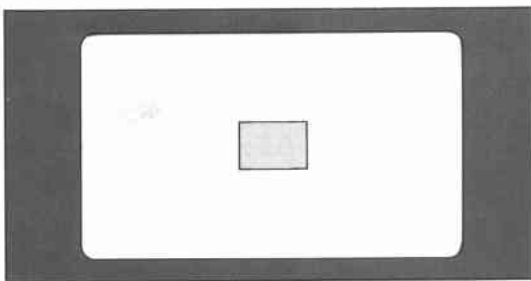

Focus is adjusted by setting the focus selector to the desired focusing mode. Three modes are available:

- 1 **Autofocus:** Set the focus selector to AUTO.
- 2 **Manual focus:** Set the focus selector to MANUAL.
For manual focus, first set the zooming lever to the maximum focal length (telephoto setting) and focus the lens. Then frame the picture as desired by zooming the lens.
- 3 **One-shot autofocus:** Push and hold the focus selector up to the ONE-SHOT AF position. When released, focus switches back automatically to manual.

- When using either of the autofocus modes, a bright rectangle denoting the autofocus area will appear in the viewfinder. When shooting, compose the picture so that the subject is in the center of the rectangle.
- Do not block the camera's autofocus window with your hand or other object during recording. Also, attach the camera cable to the cable clamp on the handgrip so that the cable does not get in the way.

Subjects Not Suited for the Autofocus System

The autofocus mechanism is designed to focus the majority of subjects, and in most cases it will perform this function very well. When centered in the viewfinder, most subjects present no problems for the system.

There are some subjects, however, which must be manually focused. They are:



1 Subjects with little or no reflectance (e.g., black hair, black curtains, fire, fireworks, etc.)

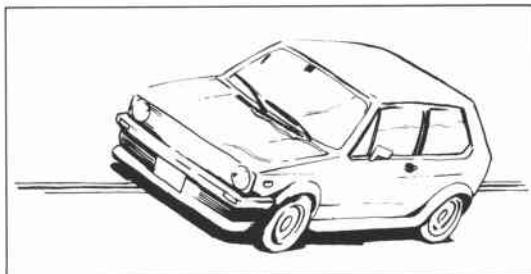

2 Subjects with very glossy or shiny surfaces (e.g., the exterior of a car, glass, etc.)



3 Subjects with an object in front of them (e.g., an animal in a cage).



4 Subjects which divide the autofocus area horizontally into one very dark and one very light section.

Focusing Subjects which Require Special Attention

A. When panning (moving the camera in a horizontal direction to follow a moving subject or to cover a wide area) in low-light conditions, autofocusing is not recommended. This is especially true when the zoom lens is set to telephoto.

In this case, first focus the subject manually or use one-shot AF. Then shoot the scene, panning as desired.

B. When focusing subjects which are not in the center of the viewfinder, please follow the steps below.



1 The desired composition



2 Point the camera at the subject and focus by pressing the focus selector up to the ONE-SHOT AF position. Then release the focus selector.



3 Recompose the scene as desired. (Focus will remain fixed.)

9 Using the Zoom Mechanism

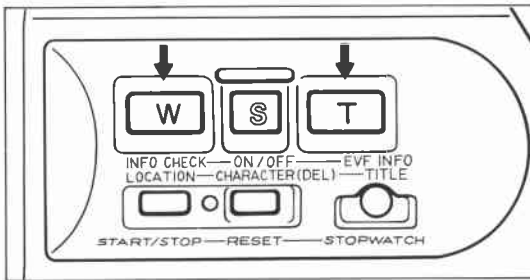

To zoom, press the power zoom switch. Push "T" to zoom in for telephoto framing. Push "W" to zoom out for wide-angle framing.

- To zoom manually, use the zooming lever.

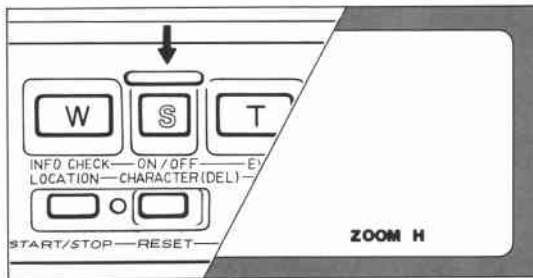

When the recorder's power VTR switch is first turned on and the camera's standby/operate switch is set to NORM or UP, the zoom speed is automatically set to low, and "ZOOM L" appears in the viewfinder.

To set the zoom speed to high, press the power zoom speed button; the viewfinder display will switch to "ZOOM H."

- The selected zoom speed is retained during the standby mode.

Recording (and Playback) Procedures

Before shooting important events, make a test recording to ensure that both the picture and sound will be properly recorded.

1

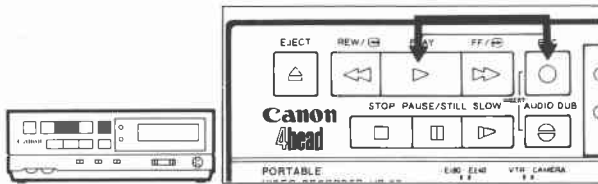

Press the recorder's record and play buttons at the same time; this places the recorder in the record pause mode.

2

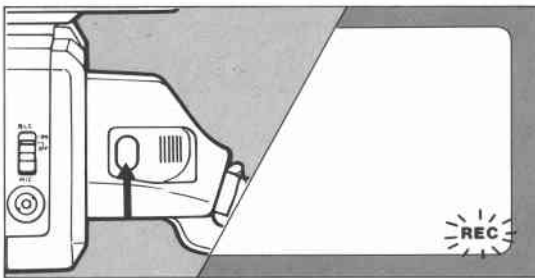

Press the camera's start/stop button to start recording. During recording, "REC" blinks in the viewfinder. The tally lamps on the front and back of the camera blink while recording is in progress. To monitor sound, connect the earphone (supplied with the recorder) to the audio output on the recorder.

3

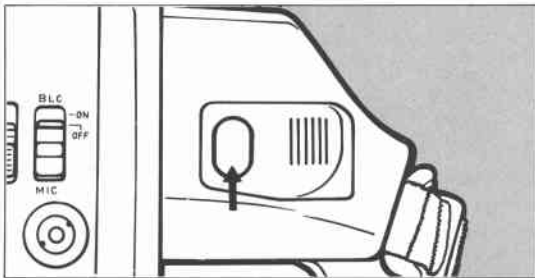

To stop recording, press the camera's start/stop button again. This places the recorder in the record pause mode.

To control such playback operations as play, slow, review, and cue, use the buttons on the recorder as you monitor the recording in the viewfinder.

4

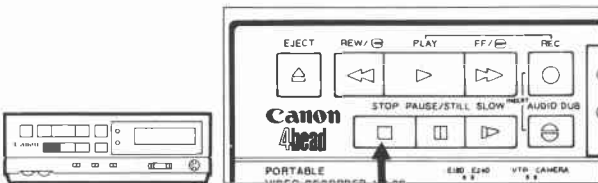

When all recording (and playback) is completed, press the recorder's stop button before turning off the recorder's VTR switch.

For details on recorder operations, please refer to the recorder instruction manual.

- It is possible to play back the recording on a monitor TV connected to the recorder.
- When recording with the VC-200 camera, DO NOT connect the Canon Control Unit CU-10 to the Canon Portable Video Recorder VR-30.
- When a videocassette reaches the end during camera recording with the VC-200 and the VR-10 or VR-30 recorder, it is automatically rewind. Remove the cassette from recorder at this time to avoid recording over and erasing its contents.

Other Operations

A. Recording a Backlit Subject

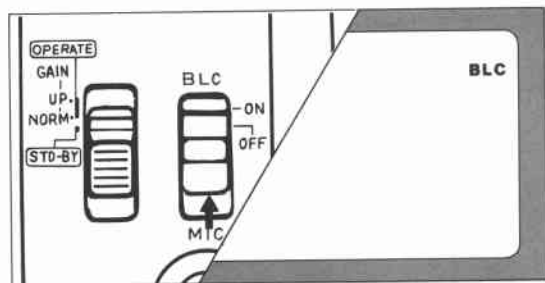

Before shooting a backlit subject, a scene with a high percentage of sky, or a subject surrounded by snow, it is necessary to compensate exposure so the subject doesn't turn out too dark. To shoot in such conditions, first set the backlight compensation switch to ON; "BLC" will appear in the viewfinder. When you have finished recording the scene, return the switch to OFF.

Important: To protect the camera tube from excessive light entry, never point the camera directly at the sun or other bright light source.



B. Using the Macro Mechanism

1

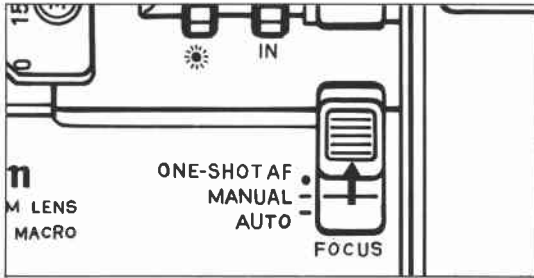

The macro mechanism is designed for shooting subjects (such as flowers, insects, and other suitable objects) from a close distance.

Set the focus selector to MANUAL.

2

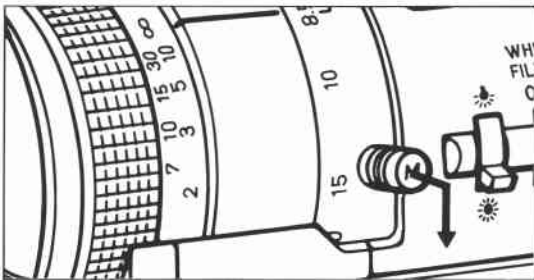

To enter the macro mode, turn the zooming lever to the wide-angle position, pull up on the zooming lever knob, and continue to turn the lever.

- To focus in the macro mode, turn the zooming lever within the macro range while watching the image in the viewfinder.
- Focusing is possible down to approximately 4 mm from the front of the lens.

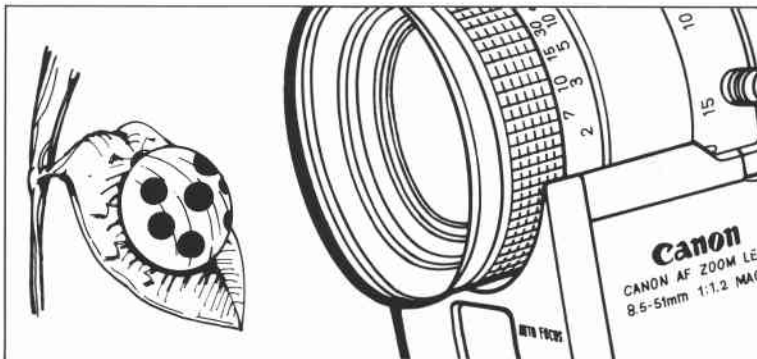

C. Using the Standby/Operate Switch

1

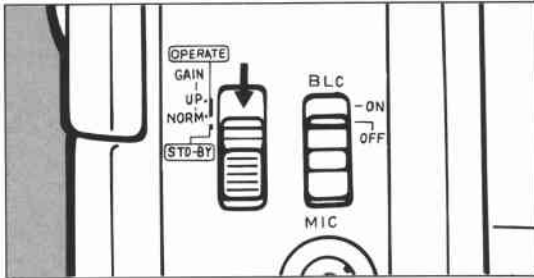

To conserve power consumption during pauses in recording (such as when you are preparing to shoot a scene), set the standby/operate switch to STD-BY. This extends the recording time possible when using a battery pack.

- 1 After recording, press the camera start/stop button again; this will place the recorder in the record pause mode.
- 2 Set the standby/operate switch to STD-BY.
- 3 To resume recording, set the standby/operate switch to NORM (or to UP).

2

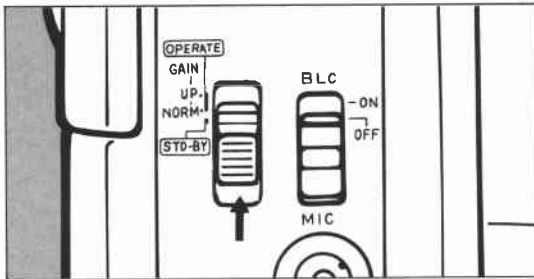

- For longer pauses (more than about 10 minutes), it is recommended to set the recorder's VTR switch to OFF.

D. Using an External Microphone

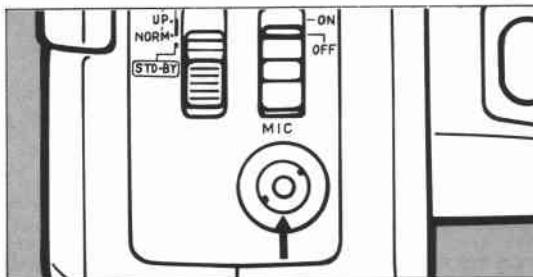

An optionally available microphone, such as the Canon Super-directional Microphone DM-100, can be connected to the camera's external microphone jack. With the microphone connected, sound from the camera's built-in microphone is not recorded.

Viewfinder Display System

The mode select button and display buttons **A** and **B** on the camera's control panel are used to select the various viewfinder displays. Display or checking of recording information, construction and recording of titles, and stopwatch recording are possible.

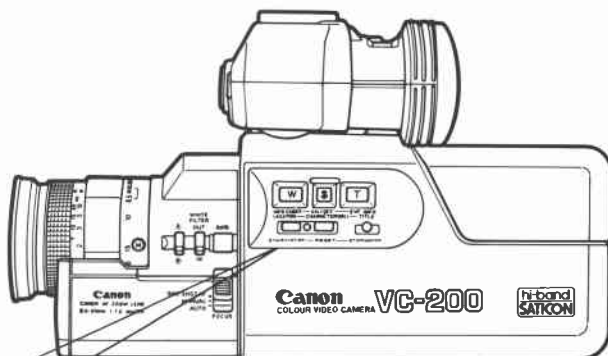

Control Panel

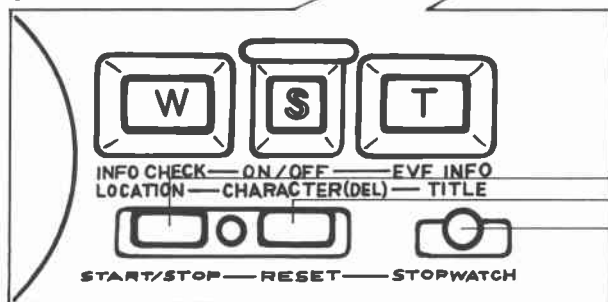

Display Button **A**

Display Button **B**

Mode Select Button

Three modes, EVF (electronic viewfinder) information mode, title mode, and stopwatch mode, are available by pressing the mode select button. Display buttons A and B control the following functions:

Mode	Button	Display Button A	Display Button B
EVF Information Mode		Information Check	Display ON/OFF
Title Mode		Character Location	Character Selection (in pause mode) Title Deletion (in record mode)
Stopwatch Mode		Start/Stop	Reset

First connect the camera, recorder and power source, then set the recorder's VTR switch to ON. When the standby/operate switch is set to NORM or UP, the initial display mode is EVF information, and recording information automatically appears in the viewfinder. Each time the mode select button is pressed, the mode changes in sequence as shown:

EVF Information mode

Title mode

Stopwatch mode

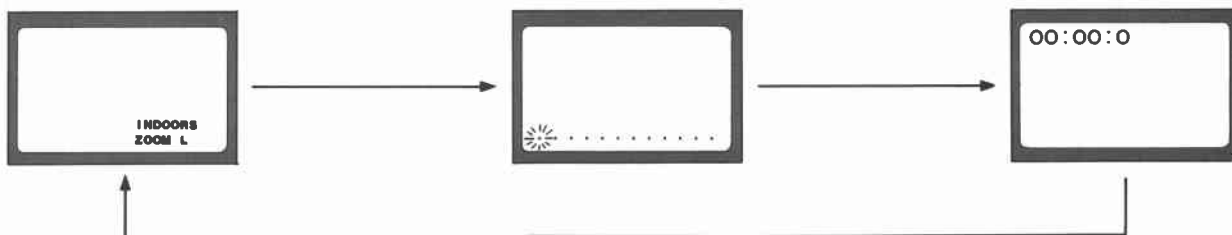

1 EVF Information Mode

In this mode, recording information is conveniently displayed in the viewfinder. The display varies according to the mode (pause or recording) the camera is in and the setting of the various camera controls. The displays are not recorded.

Displays appear in the viewfinder as shown:
(For details, refer to pp. 24, 25)

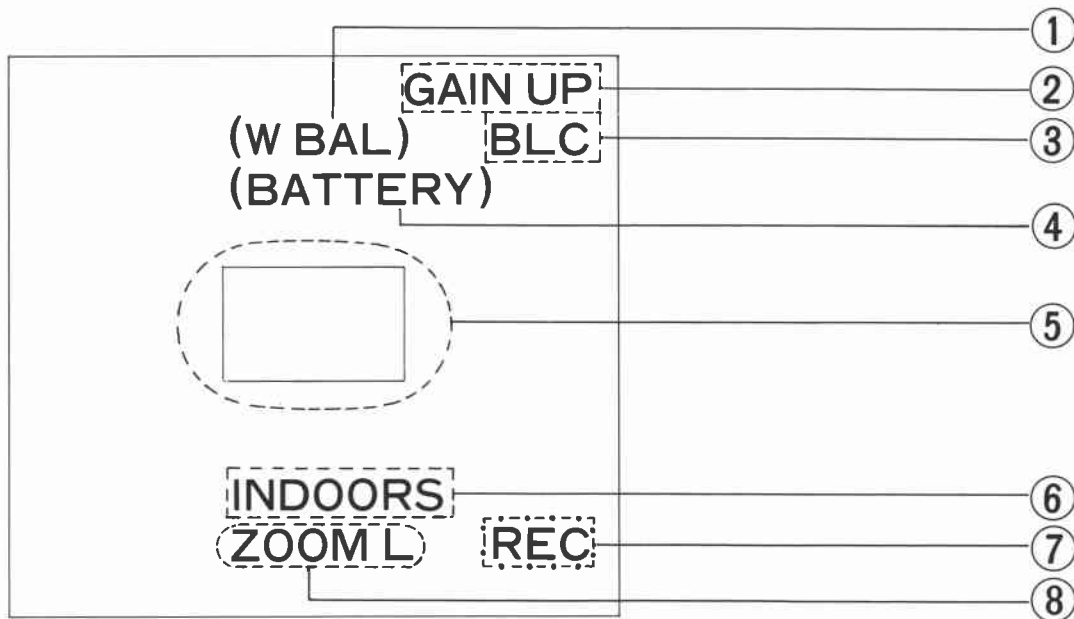

[- - -] denotes displays which appear only during pause mode.

() denotes displays which appear in warning in pause and recording modes.

[- - -] denotes display which appears only during recording.

(- - -) denotes displays which appear both during recording and pause modes.

- Displays enclosed in [- - -] and (- - -) can be deleted or displayed as desired by pressing display button **B** (ON/OFF button).

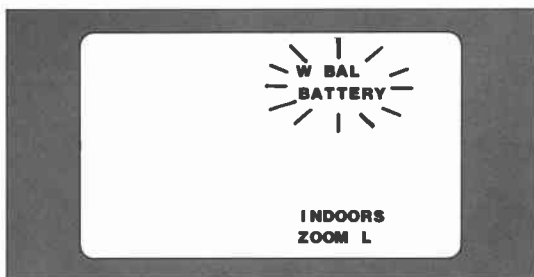

When the recorder's VTR switch is first set to ON, displays ①, ⑥ and ⑧ appear in the viewfinder. When the battery pack is exhausted, display ④ also appears.

Displays ②, ③ and ⑤ also appear if you have set the corresponding switches.

- All displays except ①, ④ and ⑤ will disappear automatically after 25 seconds. If you want to check the information again, press the mode select button three times to recall the EVF information mode.
- If you use the gain up (②) or backlight compensation (③) feature, or if you switch the filter setting (⑥) or the power zoom speed (⑧), the corresponding display will appear in the viewfinder for 25 seconds, after which it is cancelled automatically.

① White Balance Display

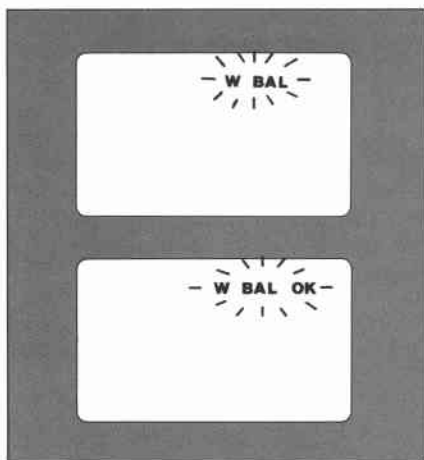

When the recorder's VTR switch is set to ON, "W BAL" automatically appears in the viewfinder. When you press the camera's AWB button to adjust white balance, "W BAL" starts blinking faster. When white balance is adjusted, the display changes to "W BAL OK". The display disappears within a few seconds.

- As long as white balance is not adjusted, "W BAL" will continue to blink slowly.
- This display appears both in the recording and pause modes until white balance is adjusted.

② Gain Up Display

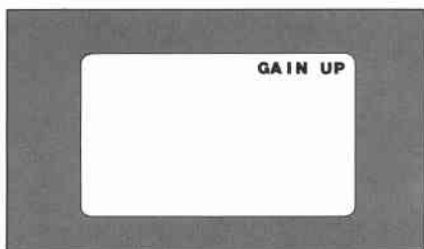

When the camera's standby/operate switch is set to UP, "GAIN UP" appears in the viewfinder.

- This display appears only in the pause mode.
- To cancel the display, press display button **ⓑ** (ON/OFF button).

③ Backlight Compensation Display

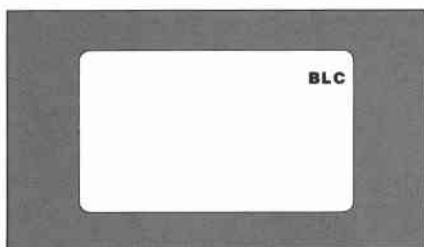

When the backlight compensation switch is set to ON, "BLC" appears in the viewfinder.

- This display appears only in the pause mode.

④ Battery Warning Display

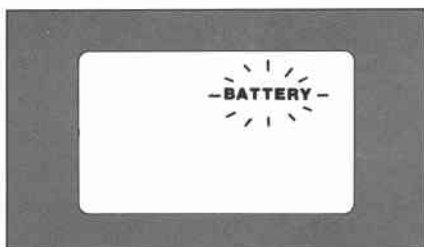

When the Canon Battery Pack BP-31 or BP-32 is used, the blinking "BATTERY" display appears when the battery charge is nearly exhausted. When the battery warning appears, check the recorder's battery level indicator to find out the amount of charge remaining. Recharge the battery or replace it with a fresh one as needed.

- This display appears in both recording and pause modes as long as the battery is exhausted.

⑤ Autofocus Area Display

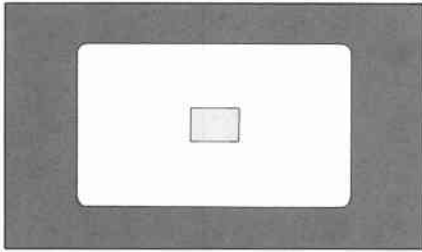

When continuous or one-shot autofocus is used, a bright rectangle appears in the center of the viewfinder to denote the area covered by the autofocus system.

- The display appears in both the recording and pause modes.
- To cancel the display, press display button **B** (ON/OFF button).

⑥ Filter Display

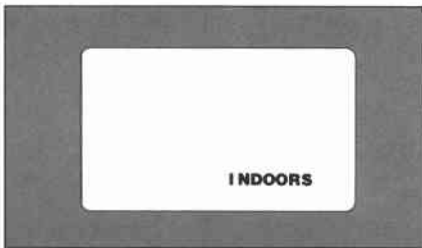

The filter display tells you the setting of the filter selector. With the selector set to ☀, "OUTDOORS" is displayed. With the selector at 🌧, "INDOORS" is displayed.

- This display appears only in the pause mode.
- To cancel the display, press display button **B** (ON/OFF button).

⑦ Recording Display

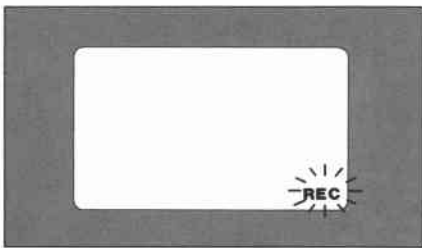

"REC" blinks during recording.

- This display shifts to the upper right corner when a title is displayed.

⑧ Zoom Speed Display

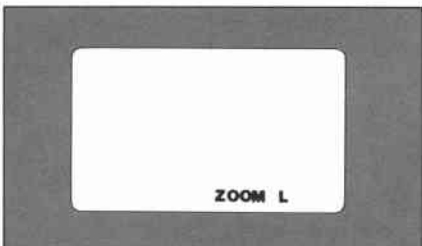

When the power zoom speed is set to low, "ZOOM L" is displayed. To switch to high speed, press the power zoom speed button; "ZOOM H" will then be displayed. When the recorder's VTR switch is first set to ON, the zoom speed is automatically set to low.

- This display appears in both the recording and pause modes.
- To cancel the display, press display button **B** (ON/OFF button).

Information Check Display

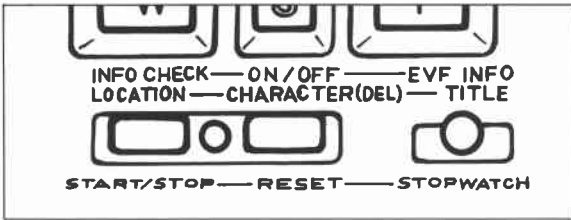

In the information check display, recording information concerning the status of six different functions is listed in the viewfinder as long as you press display button **A** (INFO CHECK button). The information is available in both the recording and pause modes. These displays are not recorded.

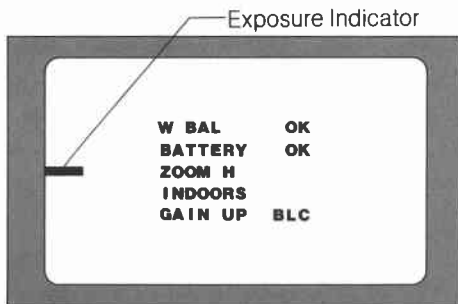

The information check display consists of the following:

Function	Display
White Balance	"W BAL OK" or blinking "W BAL"*
Battery Charge Warning	"BATTERY OK" or blinking "BATTERY"**
Zoom Speed Setting	"ZOOM L" or "ZOOM H"
Filter Selection	"OUTDOORS" or "INDOORS"
Gain Up	"GAIN UP" or no display
Backlight Compensation	"BLC" or no display

* indicates white balance is out of adjustment.

** indicates battery power is low.

2 Title Mode

In the title mode you can create and record a one-line title of 12 characters (maximum). Titles are constructed by selecting the required characters from the set.

The character set consists of letters, numbers and symbols as shown below:

ABCDEFGHIJKLMNOPQRSTUVWXYZ

VWXYZ?0123456789:.-/.

(cursor)

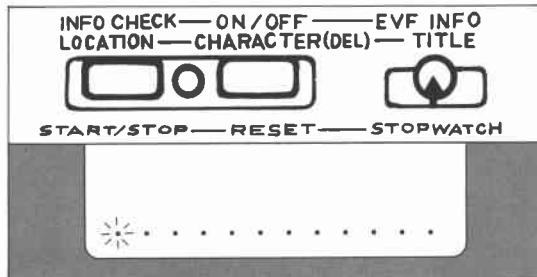
1

Select the title mode

First, place the camera in the record pause mode. (Constructing titles during recording is not possible.)

Press the mode select button to select the title mode. A line of 12 cursors denoting character positions will appear at the bottom of the viewfinder. The first cursor will be blinking.

- If a title has already been constructed, it will appear in the viewfinder. If you wish to make a new title, select new characters to replace the existing ones following the steps below.

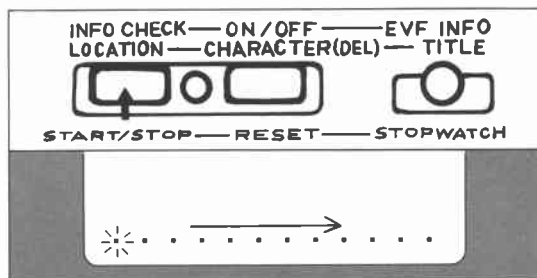
2

Select the character location

Press display button **(A)** (LOCATION button) until the blinking cursor reaches the location where the title is to start. Each time the button is pressed, the cursor moves one position to the right. After the cursor reaches the last position, it returns to the starting point.

- The blinking cursor moves continuously when display button **(A)** (LOCATION button) is held down.

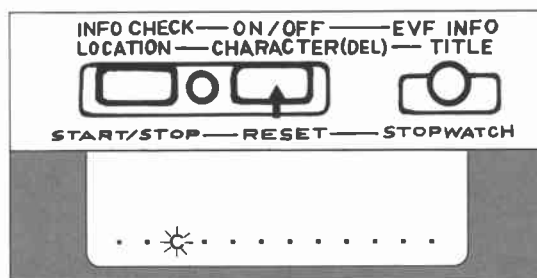
3

Select the character

With the blinking cursor at the title-starting point, press display button **(B)** (CHARACTER [DEL] button) to select the desired character. A blinking "A" will appear in place of the cursor. The character changes once in alphabetical (or numerical) order each time the button is pressed, and changes continuously when held down. After the last character in the set (a cursor) has been displayed, an "A" will appear, and the sequence begins again.

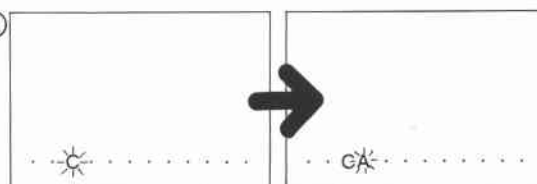
4^(a)

Select the next character

To select the next character, press display button **(A)** (LOCATION button). A blinking cursor will appear to the right of the character. Press display button **(B)** (CHARACTER [DEL] button) to select the next character.

- With each new position, "A", the first character in the set, is automatically displayed when you press display button **(B)**.

(b)

Choose a blank space

To choose a blank space, simply press display button **(A)** (LOCATION button) to move the blinking cursor to the next desired character position, leaving a cursor (or cursors) in between. (During recording, all remaining cursors will be recorded as blanks.)

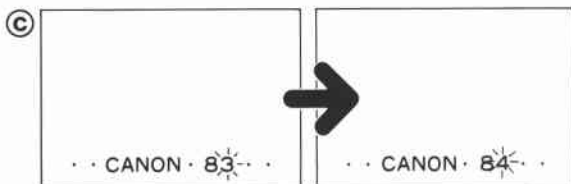

Correct the character

Corrections must be made while in the record pause mode. To make a correction, first press display button **A** (LOCATION button) until the character you wish to change blinks. Then press display button **B** (CHARACTER [DEL] button) to select the correct character.

- Character changes will begin with the next letter (or number) in the sequence.
- To delete a character, select the cursor (the last character in the set) with display button **B** (CHARACTER [DEL] button).

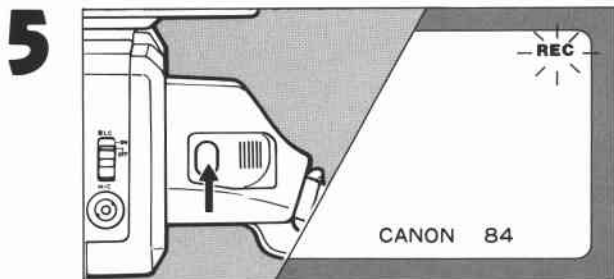

To record the completed title, press the camera's start/stop button; any remaining cursors will disappear.

- The blinking "REC" display, which appears in the top right corner, will not be recorded.
- The above procedure is for superimposing a title on the scene you are shooting. If you would like to record just the title on a blank background, cover the lens with a cap or some other suitable item.

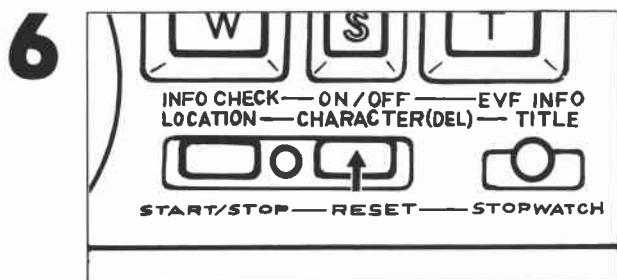

To delete the title during recording, press display button **B** (CHARACTER [DEL] button). The title will disappear from view, but it is retained in title memory.

- Title deletion is possible only during recording.

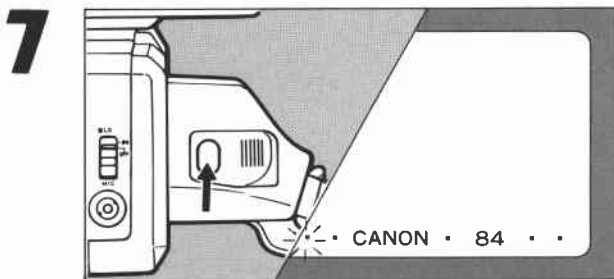

If you wish to display the title after deleting it, press the camera's start/stop button again to place the camera in the record pause mode. The title and cursors which denote blank spaces will reappear (the left cursor will be blinking).

- If you don't wish to record the title the next time you shoot, switch the title mode to the EVF information mode with the mode select button.
- The constructed title will be retained even if recording is stopped, the viewfinder display is changed to another mode (such as the EVF information or stopwatch mode), the camera is set to standby, or the recording is played back in the viewfinder, as long as the recorder's VTR switch is set to ON and the camera cable is connected.

3 Stopwatch Mode

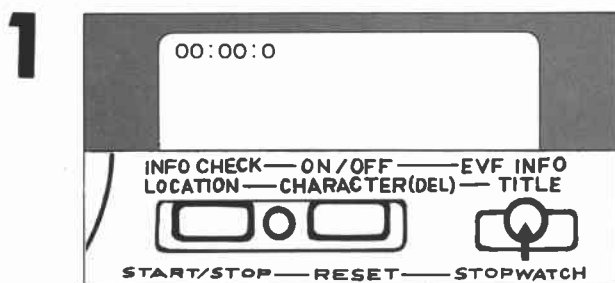

Press the mode select button to select the stopwatch mode; 00:00:0 will appear in the viewfinder's top left corner. The stopwatch counts up to 59 minutes, 59.9 seconds. After the stopwatch reaches 59:59:9, it returns to 00:00:0.

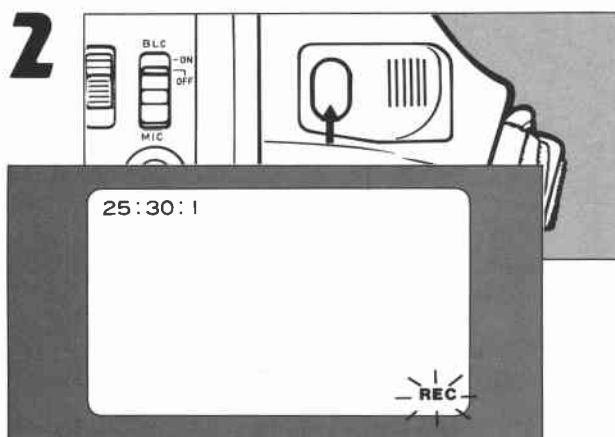

Press the camera start/stop button to start recording. (The blinking "REC" display will appear in the viewfinder's lower right corner, but it will not be recorded.)

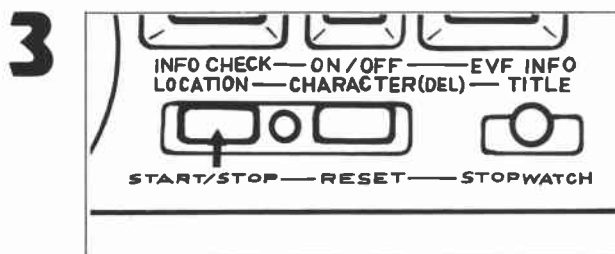

At the point you wish to start the stopwatch, press display button **A** (START/STOP button). Press the button again to stop the stopwatch.

- If you stop the stopwatch and then restart it, the stopwatch will continue counting from the point at which it stopped.

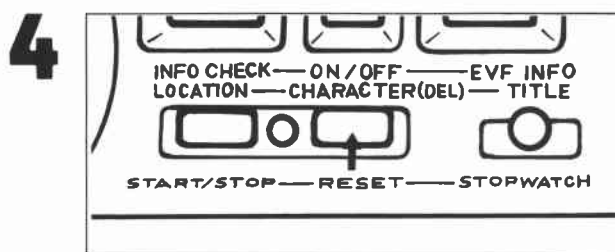

Press display button **B** (RESET button) to reset the stopwatch.

- It is possible to reset the stopwatch while it is counting.
- The stopwatch can be started and stopped in either the recording or pause mode.
- Once started, the stopwatch will continue to count, even if the camera is placed in the record pause mode or the viewfinder display is changed to another mode (such as the EVF information or title mode), until display button **A** (START/STOP button) is pressed again. (In either case, even though the stopwatch is counting, it doesn't appear in the viewfinder.)
- The stopwatch will be reset automatically if the recorder's VTR switch is set to OFF, the camera is placed in the standby mode, or the recording is played back in the viewfinder.

Optional Accessories

A number of handy accessories are available to increase the versatility of the VC-200 video camera.

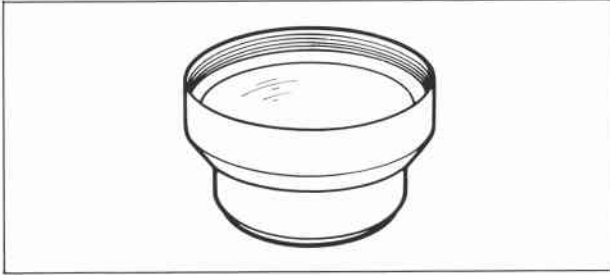

Canon Tele-converter 1.4X 46

With the tele-converter attached to the VC-200, the focal length of the camera's lens is multiplied approximately 1.4 times.

1. Unscrew the camera's lens hood.
2. Screw the tele-converter into the lens filter thread.
3. Set the camera's focus selector to MANUAL, and focus the lens by turning the focusing ring while looking in the viewfinder.
4. Shooting is possible from a distance of 1.8 m to ∞ (infinity).

- Since vignetting may occur at very short focal lengths, do not zoom to a focal length shorter than approximately 25 mm.

For details, please refer to the tele-converter's instruction manual.

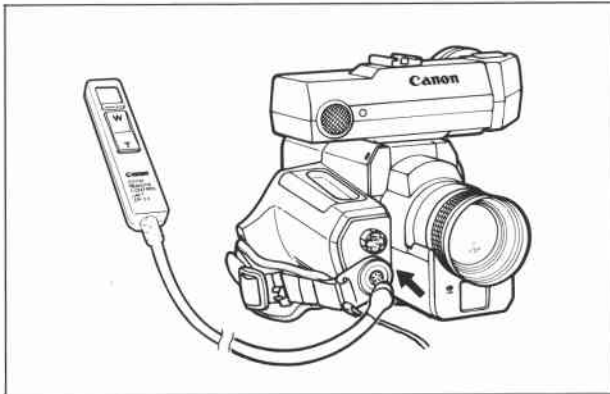

Canon Zoom Remote Control Unit ZR-20

Attached to the VC-200, the zoom remote control allows you to start and stop normal camera recording operations from a distance of up to 6 m. Auto-zooming by remote control is also possible.

1. Set the recorder's VTR switch to OFF.
2. Plug the ZR-20 cable connector into the camera's zoom remote control socket.
3. After connecting, prepare the recorder and camera for recording as usual.
The recorder's control selector can be set to either the CAMERA or VTR position.
4. Place the recorder in the record pause mode.
5. Press the ZR-20 start button to start recording. Press the start button again to stop recording.
6. Press the zoom button to operate the power zoom.

To zoom to wide-angle, press the "W" on the zoom button.

To zoom to telephoto, press the "T."

- Zooming while in the macro mode is not possible.
- Zooming speeds may be changed as usual by pressing the camera's power zoom speed button.

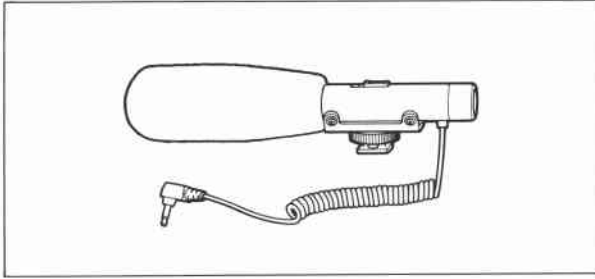

Canon Super-directional Microphone DM-100

Offering two sensitivity settings, the DM-100 microphone gives superior directional results for more precise sound recording. The microphone attaches to the camera's accessory shoe.

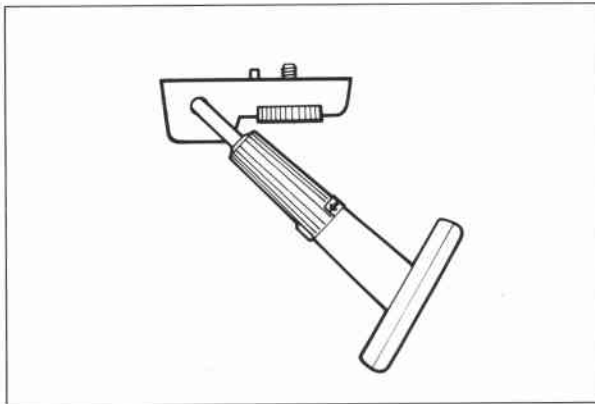

Canon Chest Pod CP-3

This accessory provides support without sacrificing mobility, making hand-held shooting steadier and easier. The chest pod attaches to the camera's tripod socket.

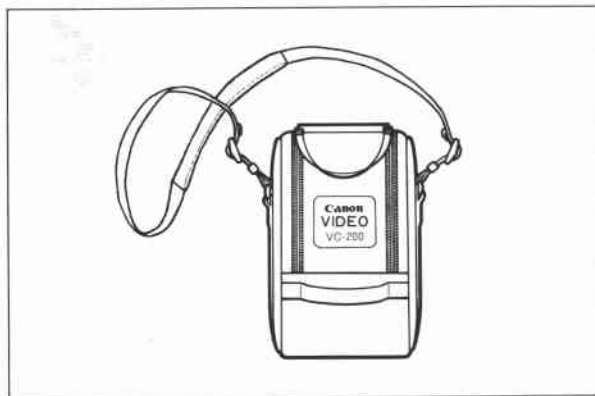

Canon Carrying Case for VC-200

The carrying case is specially designed to protect the camera against shock and scratches.

- Please insert the camera with the lens side up.

Canon Extension Cord C-10R

For greater mobility, the standard camera cable can be lengthened with the 6-meter C-10R extension cord.

Canon Videocassette Tape

For the best in viewing enjoyment, Canon offers its own line of cassettes in the most popular lengths of 30, 60, 90, 120 and 180 minutes.

Troubleshooting

If the camera appears to be operating improperly, go through the checklist below before contacting your dealer or Canon service center for repairs. You may be able to correct the problem on the spot. For details, refer to the indicated pages.

SYMPTOM

■ No picture

■ Poor color balance

■ Picture not sharp

■ The camera's start/stop button will not operate the camera.

CHECK POINT

Is the power source AC cord plugged into an AC outlet? (p. 10)

Is the recorder's VTR switch ON? (p. 12)

Is the battery pack charge sufficient? (pp. 13, 24)

Are all switches properly positioned? (p. 12)

Is the lens cap removed? (p. 13)

Are all cables properly connected? (p. 9)

Is the standby/operate switch set to NORM or UP? (pp. 13, 15, 21)

Is the white filter switch set to OUT? (p. 14)

Is there enough light for proper exposure? (p. 15)

Is the filter selector properly set? (pp. 13, 25)

Is white balance properly adjusted? (pp. 14, 24)

Is the TV set you are using properly adjusted? (See TV set operating instructions.)

If autofocusing: Is the autofocus window blocked? (p. 15)

Is the subject suitable for the autofocus system? (p. 16)

If manually focusing: Has the lens been focused correctly? (p. 15)

Is the lens dirty?

Is the zooming lever set to macro? (p. 20)

Has the recorder been placed in the record pause mode by pressing the recorder's play and record buttons at the same time? (p. 18)

Specifications

Video

Television system:	CCIR standard, PAL color signal
Scanning system:	625 lines, 50 fields
Video system:	Single-carrier frequency separation
Camera tube:	Single 1/2-inch High-band (3.9 MHz) Saticon* tube with electrostatic focusing
Video (luminance)	
S/N ratio:	Better than 45 dB
Horizontal resolution:	Better than 270 lines at center
Video output signal:	1.0 Vp-p/75 ohms (unbalanced)
Typical subject luminance:	900 lux
Minimum illumination:	20 lux (with standby/operate switch at UP)
Color temperature correction:	Two-position switch (daylight and tungsten), automatic adjustment

Lens

Lens:	f/1.2 6X power zoom, 8.5—51 mm focal length, automatic iris, macro mechanism
Construction:	14 elements in 12 groups
Angle of view:	48°55' to 9°10' (diagonal)
Focusing system:	Active autofocus; manual focusing possible
Minimum focusing distance:	1 m
Filter diameter:	46 mm

Audio

Microphone:	Unidirectional electret condenser microphone
External microphone input level:	—70 dB, low impedance, 3.5 mm mini jack
Audio output level:	—20 dB, high impedance

Other

Electronic viewfinder:	1-inch monochrome CRT
Viewfinder information:	Exposure indicator (needle type), recording indicator, white balance display, battery charge warning, filter setting display, sensitivity up display, backlight compensation display, autofocus area display, zoom speed display, title display, and stopwatch display.
Remote control:	VTR recording function controllable from camera. Camera start/stop and zooming functions controllable via Canon Zoom Remote Control Unit ZR-20 (optional accessory).
Power supply voltage:	DC 12V
Power consumption:	Approx. 6.9 W (max.) during recording; approx. 1.5 W in standby
Cable length:	1.8 m approx. (standard cable)
Dimensions:	135 (W) × 146 (H) × 250 (D) mm
Weight:	1.5 kg
Provided accessories:	Lens cap, lens hood, remote control cap, camera cable for VC-200

Subject to change without notice.

Errors and omissions excepted.

*Saticon is a registered trademark.

Canon Color Video Camera VC-200 System

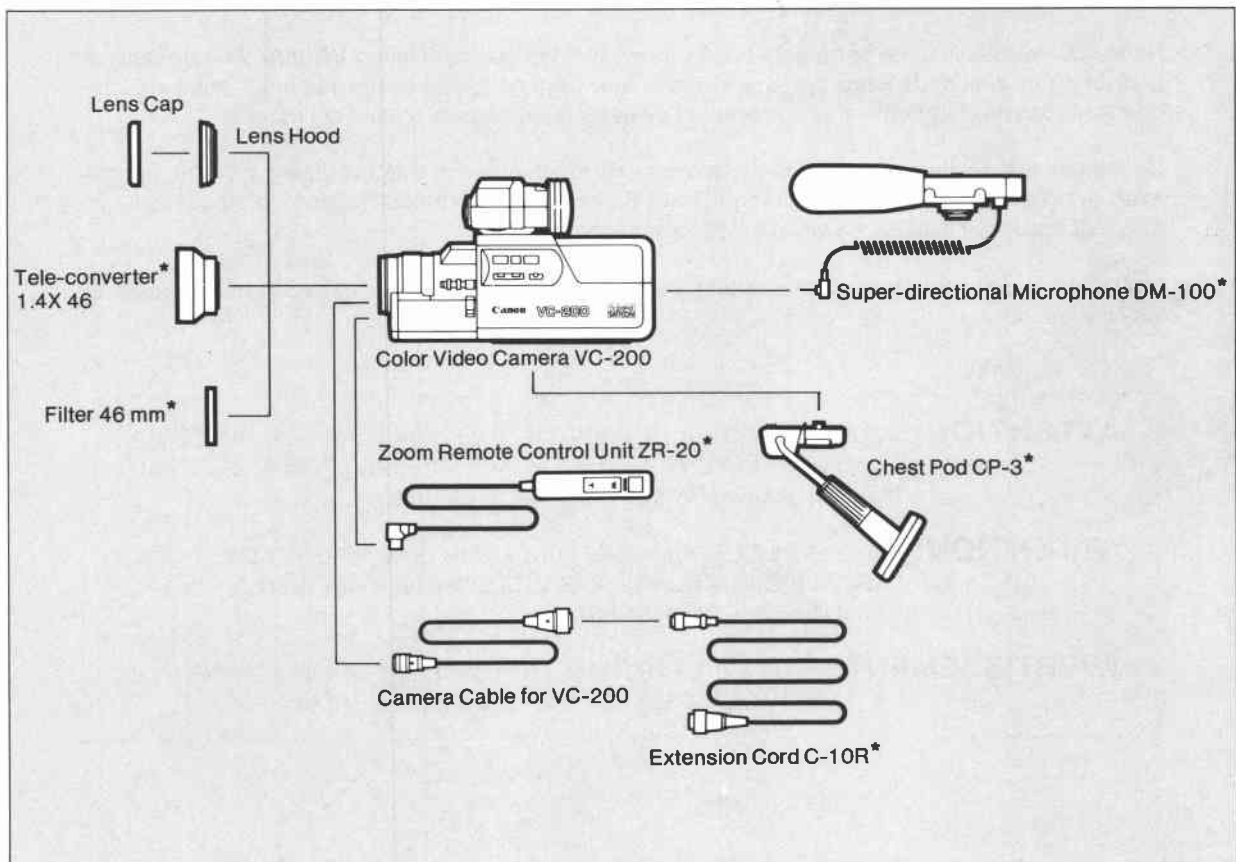

* VC-200 optional accessory.

Caméra vidéo couleur Canon VC-200

Nous vous remercions de votre achat de la Caméra vidéo couleur Canon VC-200. Afin de pouvoir profiter au maximum de votre système vidéo et tirer parti de toutes ses possibilités, nous vous recommandons de lire attentivement le présent mode d'emploi avant d'utiliser cet appareil.

Ce manuel est destiné à fournir les explications de fonctionnement de la caméra VC-200, utilisée avec le magnétoscope portatif Canon VR-30. En ce qui concerne l'utilisation du magnétoscope, prière de consulter le mode d'emploi qui l'accompagne.

La Caméra vidéo couleur VC-200 est destinée à une utilisation dans les pays où ont été adoptées les normes PAL.

ATTENTION: POUR ÉVITER D'ENDOMMAGER LE TUBE-IMAGE, NE JAMAIS ORIENTER L'OBJECTIF VERS LE SOLEIL OU UNE SOURCE DE LUMIÈRE INTENSE, MÊME SI LA CAMÉRA N'EST PAS SOUS TENSION.

ATTENTION: POUR ÉVITER LES DANGERS D'INCENDIE OU D'ÉLECTROCUTION AINSI QUE LA PRODUCTION DE PARASITES, UTILISER UNIQUEMENT LES ACCESSOIRES RECOMMANDÉS.

AVERTISSEMENT: POUR ÉVITER LES DANGERS D'INCENDIE ET D'ÉLECTROCUTION, NE PAS EXPOSER CET APPAREIL À LA PLUIE NI À L'HUMIDITÉ.