

23/20-1018

8mm VIDEO CAMCORDER

# Instruction Manual

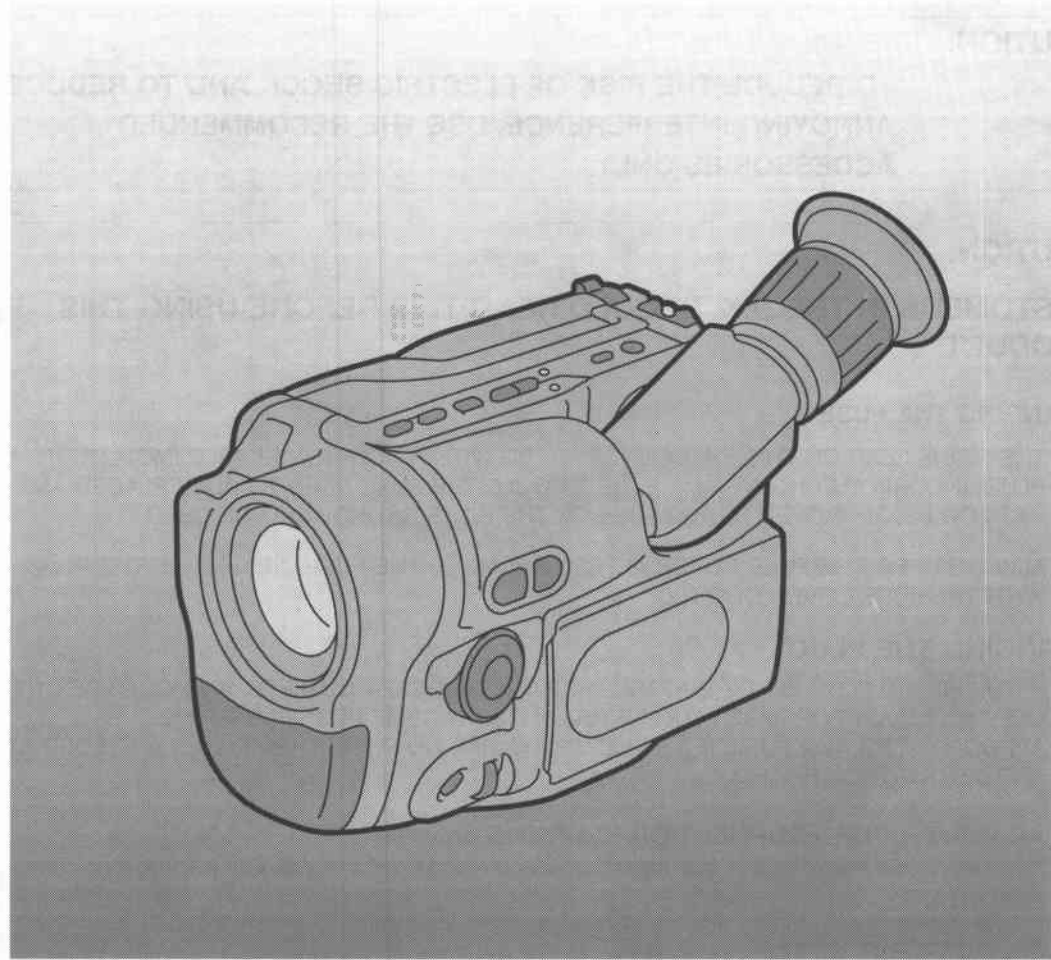

Introduction

Basic Operation

Advanced Functions

Additional Information

# Canon

## UC8Hi

P (PAL)

# Hi 8

# Important Usage Instructions

**CAUTION:**

**TO REDUCE THE RISK OF ELECTRIC SHOCK, DO NOT REMOVE COVER (OR BACK). NO USER SERVICEABLE PARTS INSIDE. REFER SERVICING TO QUALIFIED SERVICE PERSONNEL.**

**WARNING:**

**TO REDUCE THE RISK OF FIRE OR ELECTRIC SHOCK, DO NOT EXPOSE THIS PRODUCT TO RAIN OR MOISTURE.**

**CAUTION:**

**TO REDUCE THE RISK OF ELECTRIC SHOCK AND TO REDUCE ANNOYING INTERFERENCE, USE THE RECOMMENDED ACCESSORIES ONLY.**

**CAUTION:**

**CUSTOMERS IN THE U.K. SHOULD READ THIS BEFORE USING THIS PRODUCT.**

**CHANGING THE FUSE**

THE MAINS LEAD ON THIS PRODUCT IS FITTED WITH A NON-REWIREABLE (MOULDED) PLUG, INCORPORATING A 3 AMP FUSE. SHOULD THE FUSE NEED TO BE REPLACED AN *ASTA* OR *BSI* APPROVED BS1632 FUSE OF THE SAME RATING MUST BE USED.

ALWAYS REFIT THE FUSE COVER AFTER REPLACING THE FUSE. NEVER USE THE PLUG WITH THE FUSE COVER OMITTED.

**CHANGING THE PLUG**

IF THE FITTED PLUG IS NOT SUITABLE FOR YOUR SOCKET OUTLETS, IT SHOULD BE CUT OFF AND AN APPROPRIATE PLUG FITTED IN ITS PLACE. IF POSSIBLE FIT AN APPROPRIATE 3 AMP FUSE. IF THE NEW PLUG HAS NO FUSE, THEN FIT A 5 AMP FUSE AT THE DISTRIBUTION BOARD.

**AC POWER CORD CONNECTION (CA-R300B only)**

The wires in the mains lead of this apparatus are coloured in accordance with the following cord.  
**(IMPORTANT)**



As the colours of the wires in the mains lead may not correspond with the coloured markings identifying the terminals in your plug, proceed as follows: The wire which is coloured BLUE must be connected to the terminal which is marked with the letter N or coloured black. The wire which is coloured BROWN must be connected to the terminal which is marked with the letter L or coloured red. Neither Blue wire or Brown wire is to be connected to the Earth pin of a 3 pin plug.

**THE SEVERED PLUG MUST BE DESTROYED IMMEDIATELY TO AVOID ANY POSSIBLE ELECTRIC SHOCK HAZARD.**

# Introducing the UC8Hi

## FlexiZone Control

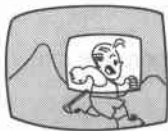

Easier than manual operation and more flexible than automatic functions, Canon's new FlexiZone Control is a completely new way to use a video camera.

## Hi8



With around 400 lines of horizontal resolution, Hi8 is the format that video professionals choose when they want high quality, long recording times and compact size.

## 20X zoom



From wide-angle to world-beating 20X telephoto — the powerful Canon lens makes it easy to get just the shot you want.

## Optical Image Stabilizer



Canon's revolutionary optical technology stabilizes your recordings even at the furthest reaches of the zoom range. Unlike ordinary electronic stabilizers, it causes zero loss of picture quality.

## Hi-fi stereo sound



The stereo microphone provides audio depth and realism that adds drama and ambience to your images. A built-in wind screen cuts wind noise to a minimum.

## Powerful recording programs



Six recording programs deal with everything from simple point-and-shoot operation to the most challenging recording conditions.

## Fade

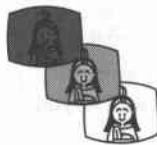

Add an atmospheric touch to your video productions with smooth fades, synchronised with the soundtrack.

## Character generator



You don't need any extra equipment to add titles to your home videos — the camera does it all.

## Remote control



The supplied wireless controller operates both recording and playback from as far away as 5 metres (16 ft).

## Manual shutter



For advanced image control, choose from eight different shutter settings. A top speed of 1/10000 second lets you capture even the quickest action.

## Easy editing



As well as versatile record search and review functions, your camera is equipped with a LANC remote control terminal, allowing easy connection to editing equipment.

# Thank you for choosing a Canon

First, we'd like to thank you for buying this Canon camcorder. Its advanced technology makes it very easy to use — you will soon be making high-quality home videos which will give you pleasure for years to come.

To get the most out of your new camcorder, you should read this manual thoroughly — there are many sophisticated features which will add to your recording enjoyment.

To get started, you will need to read these sections:

“Basic Recording”

“Power Sources”







“Cassettes”

“Preparing the Camera”

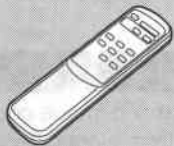
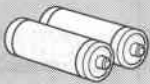
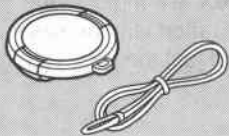
Then you can go on to find out about the more advanced features.

As well as using the alphabetical index, you can look up the different parts and functions in the sections called “Nomenclature” and “Viewfinder Displays.” There's also a “Troubleshooting” section in case you run into any problems.

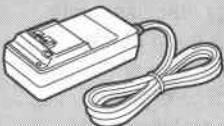
Check that this package contains the following accessories:

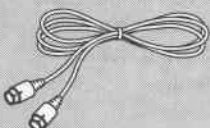
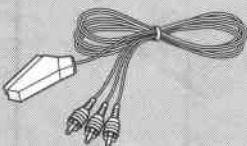
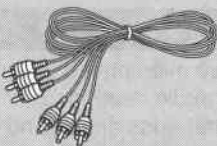
WL-60 Wireless Controller 	Two R6 AA batteries 	Lens cap and lens cap cord 	SS-300 Shoulder Strap 
BP-711 or BP-E77K Battery Pack 	Lithium battery (CR2025) 	CA-R200 or CA-R300 Compact Power Adapter 	DC-100 DC Coupler 
S-150 S-video Cable 	PC-170ST Stereo SCART Cable (Europe) 	STV-150 Stereo Video Cable (Asia, Oceania) 	

And while you are finding out how your camcorder works, remember:

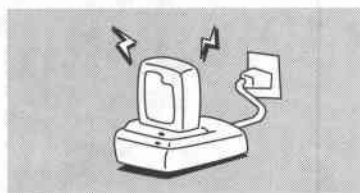

The battery pack must be charged before it can power the camcorder.

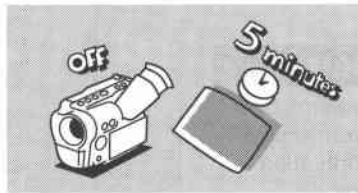

If you leave the camera in record pause mode for more than about five minutes, it will turn itself off to prevent the video heads being damaged.



If you want the superior picture quality of Hi8, you have to use Hi8 tapes. If you use standard 8mm cassettes, you will get standard 8mm recordings.

## Introduction

Important Usage Instructions .....	2
Thank you for choosing a Canon .....	3
Introducing the UC8Hi .....	4

## Basic Operation

Basic Recording .....	6
Power Sources .....	7
Cassettes .....	11
Preparing the Camera .....	12
Playback .....	13
Playback Connection .....	14

## Advanced Function

Zooming .....	17
Wireless Controller .....	18
Date and Time .....	19
Titles .....	20
Fade .....	21
Choosing a Recording Program .....	22
Focusing .....	24
Exposure Control .....	25
Manual Shutter .....	26
Record Search and Record Review .....	27
Editing to a VCR .....	28

## Additional Information

Making Better Videos .....	29
UC8Hi Video System .....	30
Optional Accessories .....	31
Cautions and Maintenance .....	34
Troubleshooting .....	36
Viewfinder Displays .....	37
Nomenclature .....	38
Specifications .....	40
Index .....	41

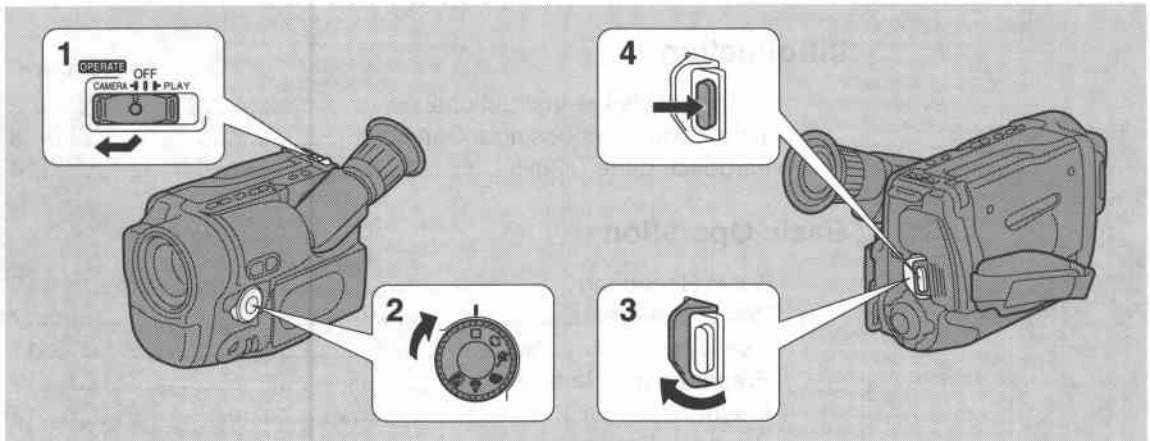
**6**

## Before you start recording

Complete the following steps:

- Attach a power source (p. 7).
- Load a cassette (p. 11).
- Adjust the viewfinder, fasten the grip belt and take off the lens cap. (p. 12).

You may also want to install the backup battery (p. 10) in order to set the date and time display (p. 19).

## To record

- 1. Set the OPERATE switch to CAMERA.**
- 2. Turn the recording program selector to .**
  - This selects the camera's Easy Recording program. It allows you to simply point and shoot without making any manual adjustments.
- 3. Open the STANDBY cover.**
  - The camera power indicator lights up red, and PAUSE appears in the viewfinder — the camera is now in "record pause mode."
- 4. Press the start/stop button to begin recording.**
  - The tally lamp flashes rapidly and REC appears in the viewfinder.
- 5. Press the start/stop button again to pause recording.**
  - The camera returns to record pause mode and PAUSE reappears in the viewfinder.
  - You can stop and restart recording as often as you like by pressing the start/stop button.
  - The camera will turn itself off if you leave it in record pause mode for more than about five minutes. To return to record pause mode, close and reopen the STANDBY cover, or set the OPERATE switch to OFF and then back to CAMERA.

**6. Close the STANDBY cover.**

- As long as the OPERATE switch is set to the CAMERA position, you can use the STANDBY cover to turn the camera on and off. This makes it easy to save battery power, and prevents accidental operation of the start/stop button.

## When you have finished recording

- Replace the lens cap.
- Unload the cassette.
- Set the OPERATE switch to OFF.
- Disconnect the power source.

**Note:**

- If you turn the camera off using the STANDBY cover, it will remember your chosen focus and shutter speed settings (and whether or not a title was displayed). If you move the OPERATE switch from the CAMERA position, these settings are erased from the memory.

Before operating your camera, you will need to use the power adapter to:

**provide power from a mains outlet**

or

**charge a battery pack**

### Notes:

- The power adapter converts current from a household mains outlet (100–240 V AC, 50–60 Hz) to the DC current used by your camera.
- If the adapter is used next to a TV, it may cause the TV to emit noise — move the adapter away from the TV or the aerial cable.

## Connecting the camera to a mains outlet

Use the power adapter and the DC coupler to provide your camera with instant power from a mains outlet.

### 1. Insert the DC coupler in the camera's power source compartment.

- Insert the front end first, then press in the DC coupler until it clicks and locks into place.

### 2. Connect the DC coupler to the adapter.

### 3. Plug the adapter into a mains outlet.

### 4. Detach the DC coupler after use.

- Press and hold the BATTERY EJECT button while you pull the DC coupler outwards from the rear.
- Always turn the camera off before removing the power source.

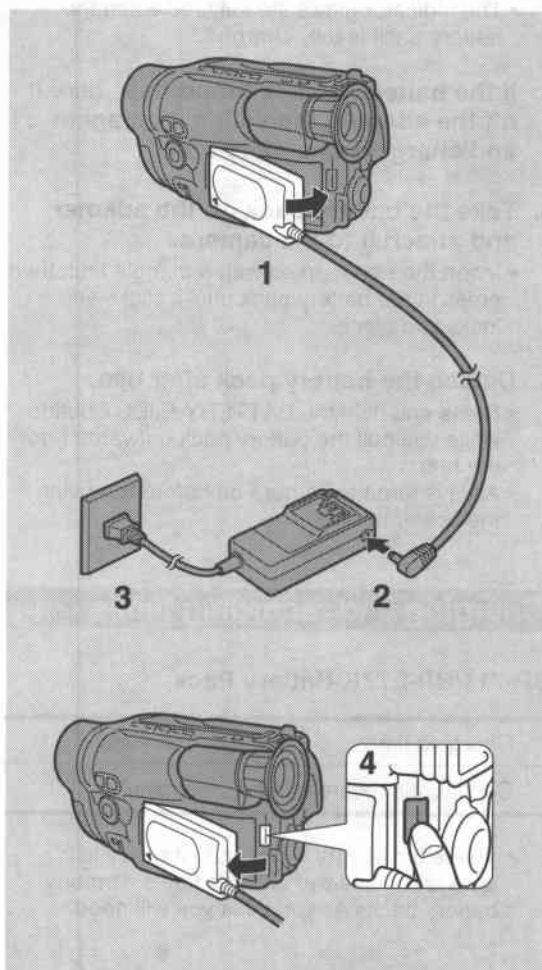

## Charging and attaching the battery pack

You will have to charge the battery pack before you can use it. A brand new battery pack must be charged twice before use.

1. **Slide the battery pack onto the adapter as shown.**
  - Make sure the DC coupler is not connected.
2. **Plug the adapter into a mains outlet.**
  - The CHARGE/REFRESH indicator flashes red to show that charging is in progress.
3. **Wait until the battery pack is fully charged.**
  - The indicator glows steadily red when the battery pack is fully charged.
4. **If the battery pack is brand new, take it off the adapter, then slide it on again and charge it one more time.**
5. **Take the battery pack off the adapter and attach it to the camera.**
  - Insert the end marked with a triangle first, then press in the battery pack until it clicks and locks into place.
6. **Detach the battery pack after use.**
  - Press and hold the BATTERY EJECT button while you pull the battery pack outwards from the rear.
  - Always turn the camera off before removing the power source.

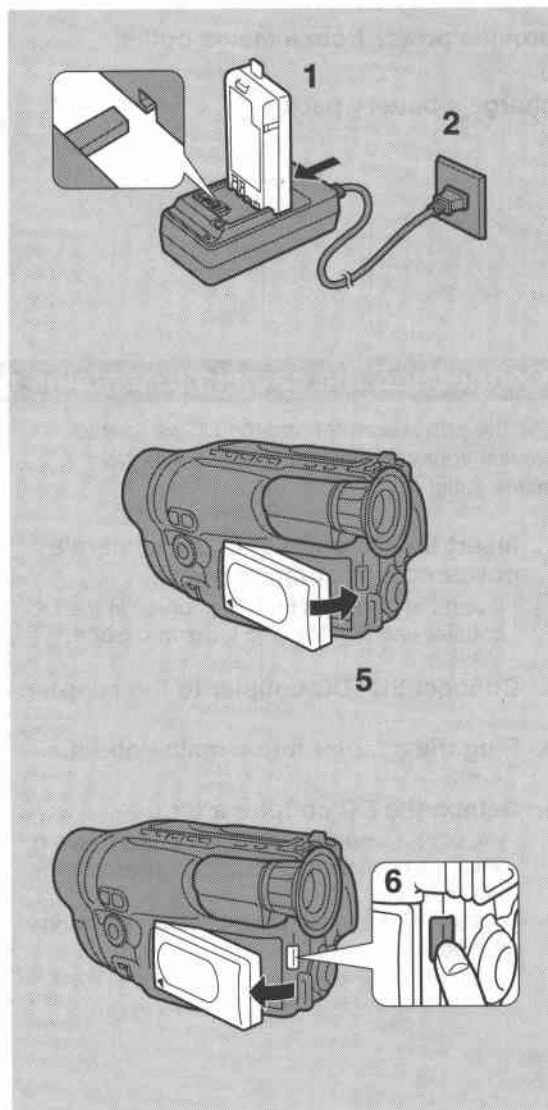

## Charging and recording times

### BP-711/BP-E77K Battery Pack

Charging time	70 minutes
---------------	------------

Continuous recording time	40 minutes
---------------------------	------------

- These times vary — the safest policy is always to have two or three times as many battery packs as you think you will need.

#### NOTE FOR CUSTOMERS IN THE EUROPE



Cd

NICKEL-CADMIUM BATTERY.  
MUST BE RECYCLED OR  
DISPOSED OF PROPERLY.



## Battery pack notes

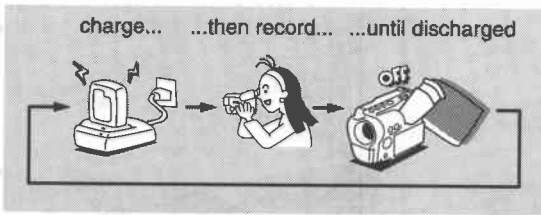

### Charge the battery pack before you use it...

- You should charge a brand new battery pack twice before using it for the first time — a single charge may not be enough. Charge it completely (until the adapter's charge indicator glows steadily), then disconnect it and charge it again. Normally, you should not "double charge" the battery pack in this way.
- The battery pack will naturally discharge itself over time. You should charge it the same day you plan to use it, or the day before.
- The battery pack becomes warm during use (and during charging). Wait for it to cool before charging or using it again.
- See the adapter instructions for details.

### ...save power while you are recording...

- You will get more recording time from your battery pack if you turn the camera off between shots, instead of leaving it in record pause mode.
- Recording time will be shorter than usual at low temperatures. You can use the battery pack between 0° and 40°C (32°–104°F), but it works best between 10° and 30°C (50°–86°F).

### ...and don't recharge it until it is exhausted.

- The camera flashes a  warning when the charge has almost run out. After a few more minutes' use, the camera turns off automatically. You can now either recharge or store the battery pack.

### Disconnect the battery pack when you are not using it.

- Even when it is turned off, the camera will continue to slowly drain power from the battery pack. This means the battery pack will be discharged beyond the normal level if you leave it attached for a long time.

### Keep the terminals clean.

- The camera, adapter or battery pack will not work properly if the terminals are dirty. Check them before use, and wipe them with a dry cloth or tissue if necessary.

## DANGER!

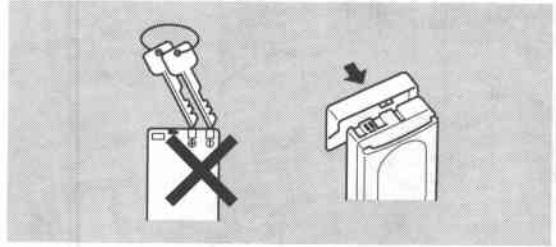

### Always attach the terminal cover.

- Do not allow any metal objects to touch the terminals. The battery pack contains a great deal of energy and short-circuiting it may cause a fire. Attach the terminal cover whenever you are not using the battery pack.

### Treat the battery pack with care.

- Keep it away from fire (or it might explode).
- Do not try to disassemble or modify it.
- Do not drop or knock it.
- Do not get it wet.

### Remember, it may start to give you less recording time...

- If you recharge it without first completely discharging it.
- If you leave it attached to the camera (or a video light) for more than a week.
- If you don't use it for three months or more.

### ...but you should be able to "refresh" it.

- The power adapter has a refresher function which restores battery packs to full capacity (see p. 10).
- If this does not improve the battery pack's performance, it has reached the end of its life and must be replaced.

## Refreshing the battery pack

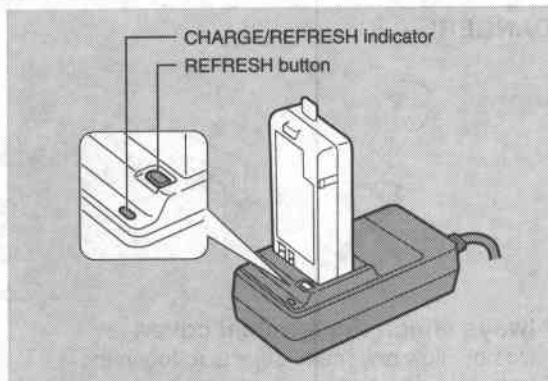

If the battery pack starts to give less recording time, use the adapter's refresher function to restore it to full capacity. The adapter will first discharge the battery pack, and then recharge it.

### 1. Attach the battery pack to the adapter and plug it into a mains outlet.

- See p. 8.

### 2. Press the REFRESH button.

- The CHARGE/REFRESH indicator flashes green to show that discharging is in progress. When the battery pack is discharged, the indicator begins to flash red and recharging begins.

### 3. Remove the battery pack when discharging/recharging has finished.

- The indicator glows steadily red when recharging is completed.
- If you only want to discharge the battery pack, there is no need to plug in the adapter. In this case, you can remove the battery pack when the CHARGE/REFRESH indicator stops flashing green.

## Discharge and recharge times

Battery pack	BP-711/BP-E77K	BP-729
Discharge	4 hr.	10 hr.
Recharge	1 hr. 10 min.	2 hr. 30 min.
Total refresh charge	5 hr. 10 min.	12 hr. 30 min.

- These times are approximate.

## Installing the backup battery

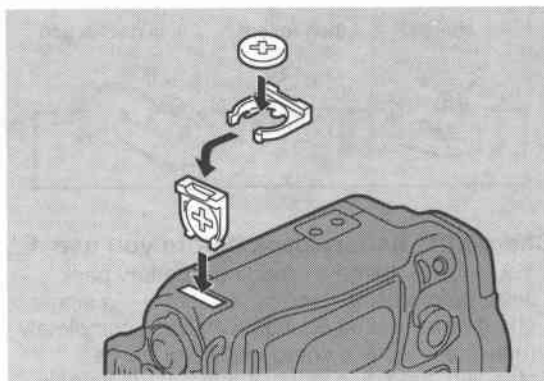

Pull out the battery holder from the base of the camera, and insert the CR2025 lithium battery with the + side facing upwards. Click the holder back into place.

This backup battery allows the camera to remember the date and time and other settings when the main power source is removed. It has a life span of about a year.

When it needs replacing (or if it has not been installed), the  mark flashes in the viewfinder. When you replace the old battery, make sure to attach a power source to the camera first, and turn it off using the STANDBY cover. This way it will remember your chosen settings when you change the battery.

### WARNING!

The battery used in this device may present a fire or chemical burn hazard if mistreated. Do not recharge, disassemble, heat above 100°C (212°F) or incinerate. Replace the battery with a Sony, Sanyo or Panasonic CR2025, or Duracell DL2025. Use of another battery may present a risk of fire or explosion. The used battery should be handed back to the supplier for safe disposal.

### Cautions:

- Do not pick up the battery using tweezers or other metal tools — this will cause a short circuit.
- Wipe the battery with a clean, dry cloth to ensure proper contact.
- Keep the battery out of reach of children — if the battery is swallowed, consult a physician immediately as the battery case may break down and the battery fluids may damage the stomach and intestines.
- Do not disassemble, heat, or immerse the battery in water, to avoid the risk of explosion.

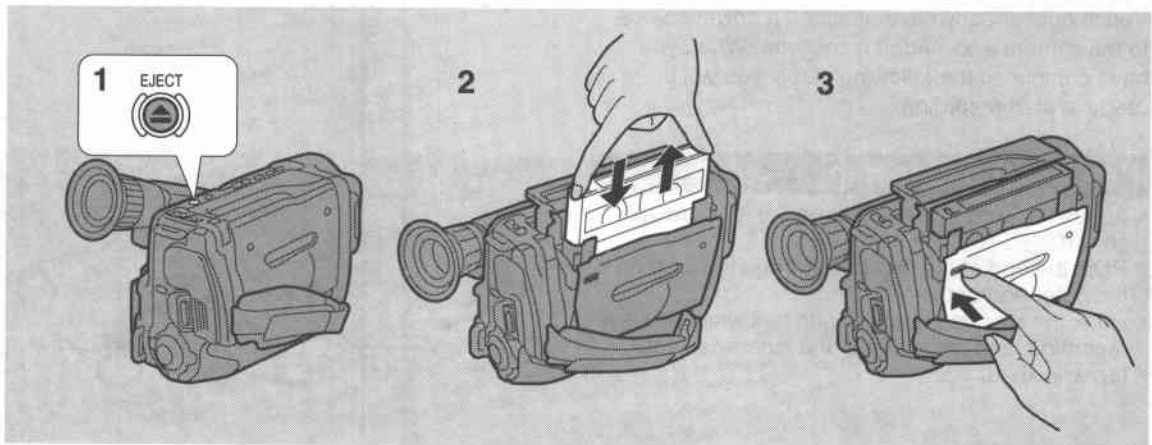

Use videocassettes marked with an **Hi8** or **Hi8i**.

## Loading and unloading

Cassettes can be loaded and unloaded with the camera turned off, as long as a power source is attached.

1. Press the **EJECT**  button and wait for the cassette compartment to open.
2. Load/unload the cassette.
  - Insert the cassette gently with the window facing out.
  - Remove the cassette by pulling it straight out.
3. Press the **PUSH** mark on the compartment until it clicks, and wait for it to close.
  - Never push down the top of the compartment.

## Selecting the tape speed

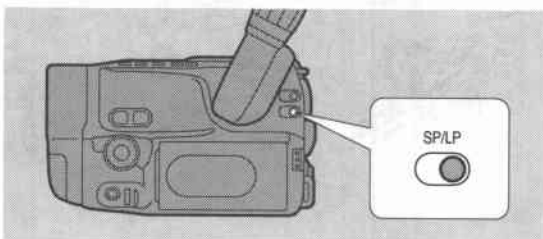

You have a choice of two recording speeds:

- Standard Play (SP) for maximum quality
- Long Play (LP) for double recording time

You can change the tape speed by pressing the SP/LP button. (SP or LP is displayed in the viewfinder.) Change tape speed in record pause mode — changing during recording will cause noise on the tape.

The camera automatically selects the appropriate speed for playback.

## Preventing accidental erasure

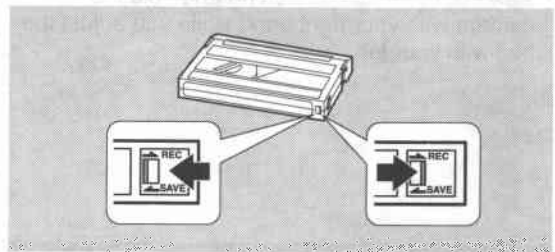

To protect your recordings from accidental erasure, slide the red switch on the cassette so that it covers the hole. (This switch position is usually labelled **SAVE** or **ERASE OFF**). When this cassette is loaded, the  mark will flash in the viewfinder if you set the OPERATE switch to CAMERA.

If you want to record on the cassette again, slide the red switch back so the hole is open. (This position is usually labelled **REC** or **ERASE ON**.)

### Notes:

- Do not interfere with the compartment while it is opening or closing automatically.
- After loading a cassette, use record search (p. 27) to find the point where you want to start recording.
- To record or play back in the Hi8 format, you need both a Hi8 cassette and a Hi8 camcorder. A Hi8 camcorder can record or play back in either the Hi8 format or standard 8mm format, depending on the tape used.
- You can use both Metal-P and Metal-E Hi8 cassettes.
- Do not leave the cassette in the camera after use — return it to its case and store it in a cool, clean, dry place.
- The holes in the back of the cassette are used for transferring information — do not cover them.

# Preparing the Camera

E

You should already have attached a power source to the camera and loaded a cassette. When you have completed the following steps, you will be ready to start recording.

## Prepare the lens cap

- Attach the cord to the eyelet on the lens cap, as shown.
- Pass the end of the grip belt through the loop on the other end of the cord.
- Hook the lens cap onto the grip belt while you are recording, and place it over the lens when you have finished.

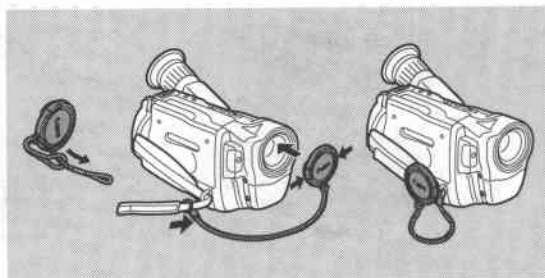

12

Basic Operation

## Fasten the grip belt

- Release the Velcro fastening and hold the camera with your right hand while you adjust the belt with your left.

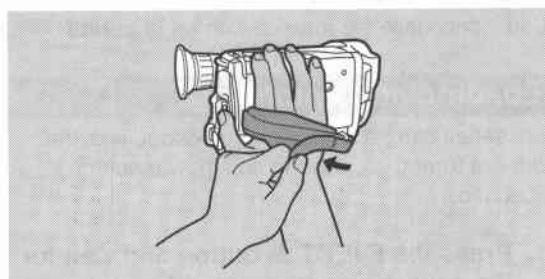

## Adjust the viewfinder

- You need to adjust the viewfinder to suit your eyesight. First, put the camera in record pause mode. (Set the OPERATE switch to CAMERA and open the STANDBY cover.) Then turn the viewfinder focusing ring until the viewfinder displays are clearly focused.
- The viewfinder rotates through 90° to give a choice of shooting positions.

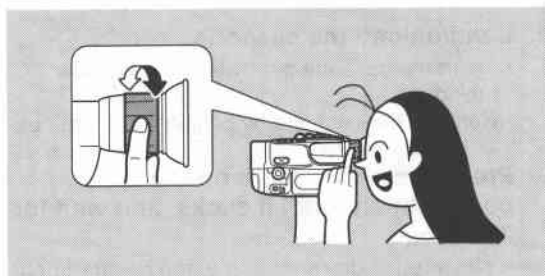

## Attach the shoulder strap

- For extra security and portability, attach the shoulder strap before using the camera.
- Pass the ends through the attachment bars and adjust the length as shown.

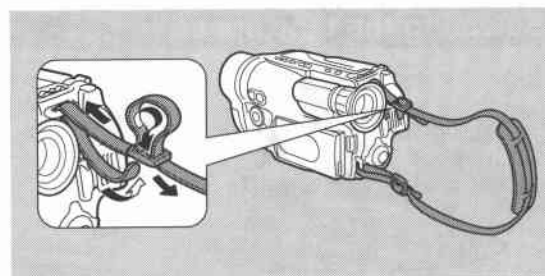

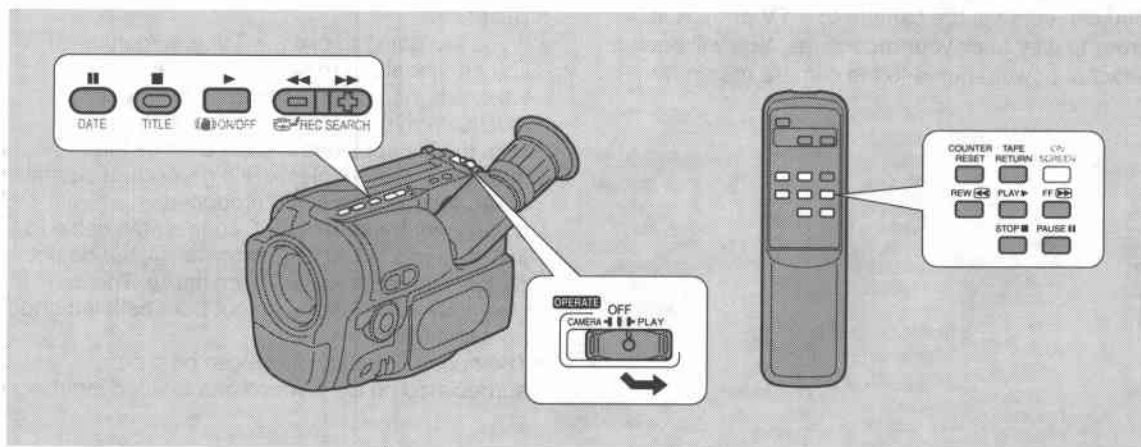

You can use the viewfinder screen for instant, on-the-spot playback.

To play back your recordings on a TV, see p. 14.  
To use the wireless controller, see p. 18.

### 1. Attach a power source and set the OPERATE switch to PLAY.

- The playback power indicator lights up green.

### 2. Load the cassette.

### 3. Press the ► button to start playback.

- To end playback, press the ■ button.
- To wind the tape forwards, stop playback and press the ►► button.
- To wind the tape backwards, stop playback and press the ◀◀ button.

## Special playback

### Still playback

Press the ■ button. To resume normal playback, press it again, or press the ► button. The camera automatically goes into stop mode after about five minutes' still playback.

### Fast forward playback

To play back the recording at about 9 times normal speed, press and hold the ►► button during normal playback.

### Rewind playback

For reverse playback at about 7 times normal speed, press and hold the ◀◀ button during normal playback.

### High-speed search

To play back the recording at about 15 times normal (SP) speed, press and hold the ►► button during normal fast forward. For reverse playback at about 15 times normal (SP) speed, press and hold the ◀◀ button during normal rewind.

## Tape return

Use the wireless controller's TAPE RETURN button to quickly return to a scene you want to see again:

### 1. Press the COUNTER RESET button during playback if you come across a scene you want to watch again later.

- The tape counter is reset to 0:00:00.

### 2. When you have ended playback, press the TAPE RETURN button.

- The tape rewinds and stops when the counter nears 0:00:00.
- You can cancel tape return by pressing the ■ button.

### 3. Start playback.

### Notes:

- Noise bars appear on the screen during special playback and the soundtrack cannot be heard. On certain TVs the picture may roll and divide, or appear in black and white, and the high-speed search picture may not be visible.
- During still playback, the picture flickers, and fast action scenes may appear blurred.
- The tape counter is reset when a cassette is loaded.
- When recording in LP mode, actual recording length is approximately twice the tape counter time.

# Playback Connection

You can connect the camera to a TV or VCR in order to play back your recordings. You will need to attach a power source to the camera (see p. 7).

### Notes:

- If you are going to use the TV as a monitor while you are shooting, remember to keep the TV volume turned down as long as the camera's AUDIO terminals are connected. If the sound from the TV speakers is picked up by the microphone, an unpleasant high-pitched squeal, called feedback, may be produced.
- If you want a mono output, connect the cable to the camera's left AUDIO terminal (L), but do not connect the right AUDIO terminal (R). This will give a combined mono output from both left and right channels.
- The superior quality of Hi8 can best be appreciated on a TV which has S-video input.

## If your TV (or VCR) has a SCART terminal (S-video)

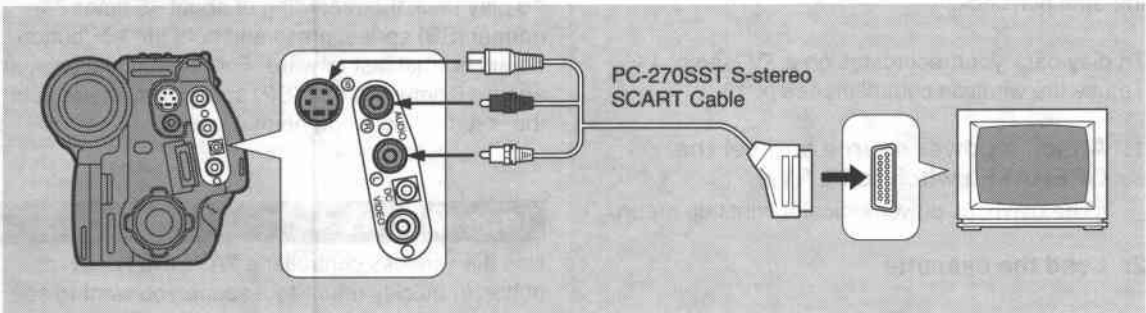

### 1. Connect the camera to the TV (or VCR).

- Use the PC-270SST S-stereo SCART Cable. Connect the white plug to the white AUDIO terminal (L) (left). Connect the red plug to the red AUDIO terminal (R) (right). Connect the S-video plug to the S-video terminal (S).

### 2. If you are connecting the camera to a VCR, set the input selector on the VCR to LINE.

- See your VCR instruction manual for details.

## If your TV (or VCR) has a SCART terminal (without S-video)

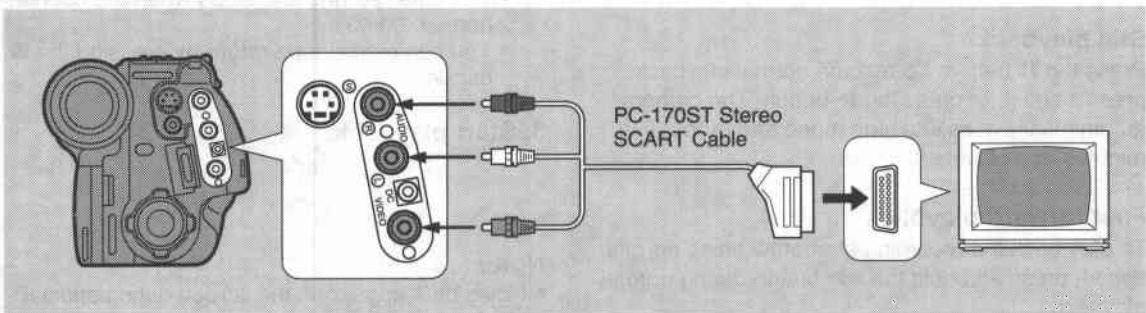

### 1. Connect the camera to the TV (or VCR).

- Use the PC-170ST Stereo SCART Cable. Connect the white plug to the white AUDIO terminal (L) (left). Connect the red plug to the red AUDIO terminal (R) (right). Connect the yellow plug to the yellow VIDEO terminal (V).

### 2. If you are connecting the camera to a VCR, set the input selector on the VCR to LINE.

- See your VCR instruction manual for details.

## If your TV (or VCR) has an S-video input terminal

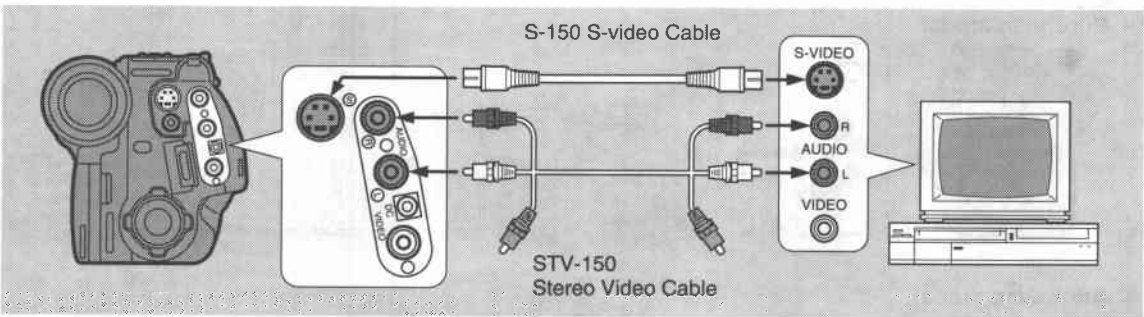

### 1. Connect the camera to the TV (or VCR).

- Use the S-150 S-video Cable to connect the S-video terminal (S).
- Use a stereo cable, or the STV-150 Stereo Video Cable, to connect the AUDIO terminals. Connect the white plug to the white AUDIO terminal (L) (left). Connect the red plug to the red AUDIO terminal (R) (right). Do not connect the yellow plug if you are using the STV-150 Stereo Video Cable.

### 2. Set the TV/VIDEO selector on the television to VIDEO.

### 3. If you are connecting the camera to a VCR, set the input selector on the VCR to LINE.

- See your VCR instruction manual for details.

## If your TV (or VCR) has audio/video input terminals

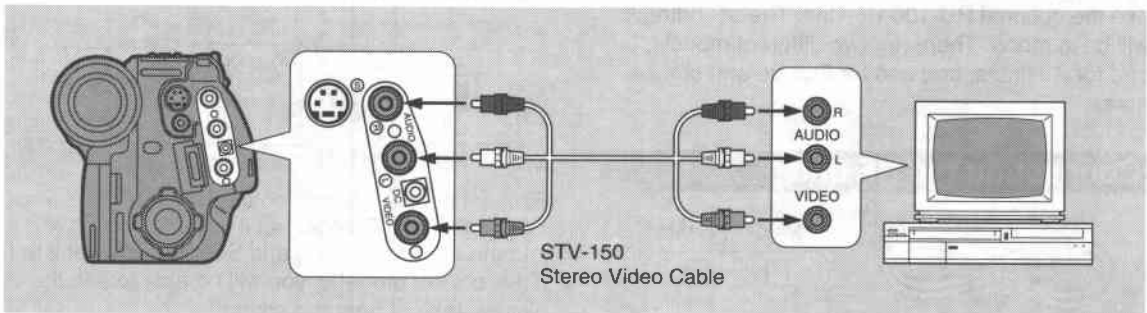

### 1. Connect the camera to the TV (or VCR).

- Use the STV-150 Stereo Video Cable. Connect the white plug to the white AUDIO terminal (L) (left). Connect the red plug to the red AUDIO terminal (R) (right). Connect the yellow plug to the yellow VIDEO terminal (V).

### 2. Set the TV/VIDEO selector on the television to VIDEO.

### 3. If you are connecting the camera to a VCR, set the input selector on the VCR to LINE.

- See your VCR instruction manual for details.

## If your TV does not have audio/video input terminals

### European model

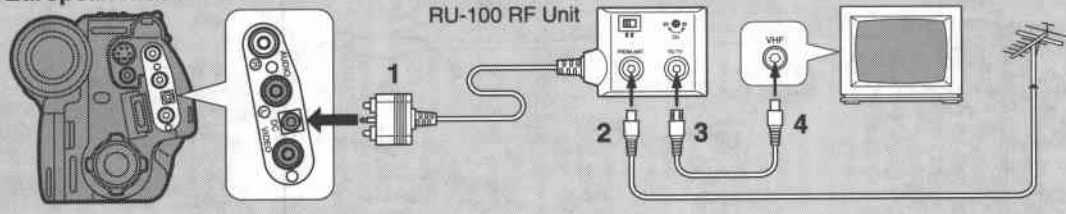

### Australian model

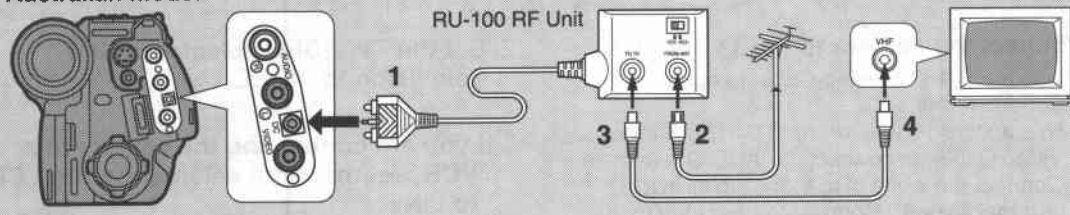

16

Basic Operation

If your TV is already hooked up to a VCR, you can connect the camera to the VCR instead of the TV. Follow the instructions on p. 14 or 15.

To connect the camera directly to a TV which does not have audio/video terminals, you will need to use the optional RU-100 RF Unit. The soundtrack will be in mono. There are two different models, one for Australia, and one for Europe and other areas.

## Connecting the RF unit

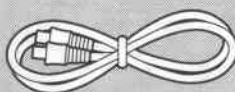

Coaxial cable with DIN-connectors

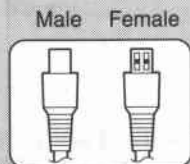

1. Connect the RF unit to the camera.
2. Connect the aerial cable to the FROM ANT. terminal on the RF unit.
3. Connect the "female" DIN-connector on the coaxial cable to the TO TV terminal on the RF unit.
4. Connect the "male" connector to the aerial input on the TV.
5. Turn the TV on, and start playback on the camera.
  - See p. 13 for playback.
6. Set both the TV and the RF unit to the video channel.

## Selecting the video channel

The video channel is the channel which is not used by a broadcasting station in your area and can be used for cassette playback.

### European model

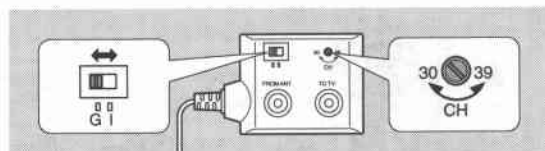

First set the G/I selector on the RF unit.

- In continental Europe, set it to G.
  - In the UK, Hong Kong and South Africa, set it to I.
- If it is not set properly, you will be able to see the picture, but not hear the sound.

Next, set the TV and the CH selector on the RF unit to the video channel. The selector is factory-set to channel 32. Adjust it by turning until the picture is clear.

### Australian model

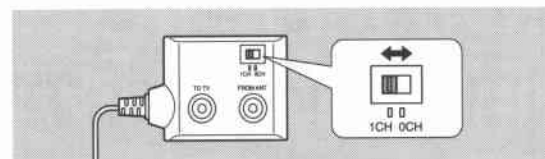

Set the TV and the RF unit to channel 0 or 1.

### Note:

- Turn the camera off or disconnect it from the RF unit when you want to watch a broadcast programme. If you leave the camera connected and turned on, the RF unit will automatically select the camera signal instead of the broadcast signal.



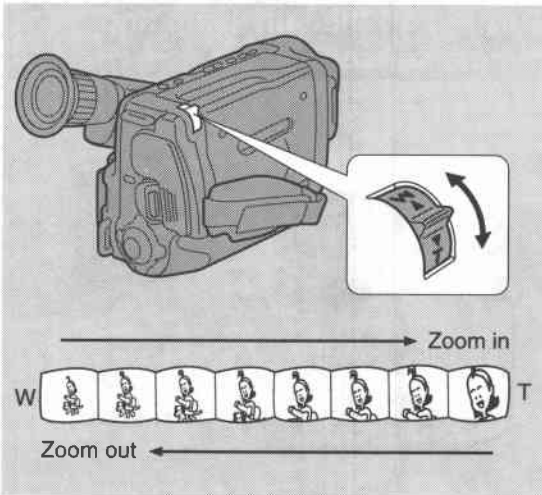

The camera's 20X zoom lens allows you to choose the best picture angle for each scene:

- Turn the zoom control towards W to zoom out to wide-angle.
- Turn it towards T to zoom in to telephoto.

You can also control the speed of zooming:

- Move the control slightly to zoom slowly.
- Turn it further to zoom more quickly. (The further you turn the zoom control, the faster the zoom speed.)

The T and W buttons on the wireless controller adjust the picture angle, but not the zoom speed:

- Press W to zoom out to wide-angle.
- Press T to zoom in to telephoto.

## Viewfinder displays

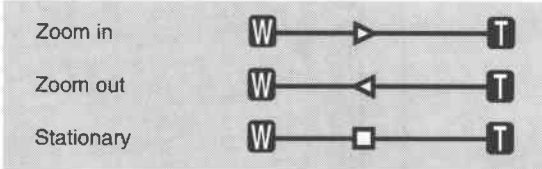

## Optical Image Stabilizer

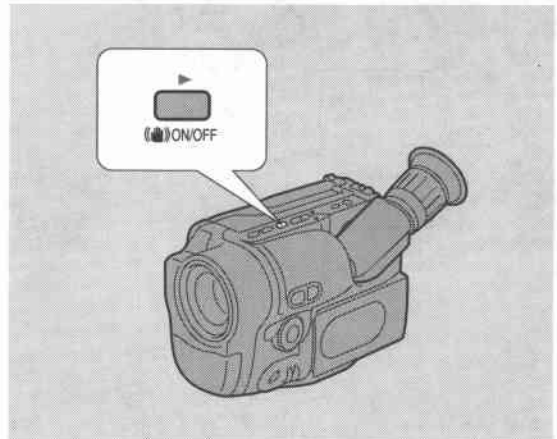

With most camcorders, even the slightest hand movements will be noticeable during telephoto recording. However, the UC8Hi's Optical Image Stabilizer allows you to obtain steady recordings even at 20X magnification. Unlike electronic image stabilizers, it causes no loss of picture quality. The Optical Image Stabilizer can compensate for a wide range of camera movement — you can record stable images even if you are shooting from a moving car.

Before you start recording push the (ON/OFF) ON/OFF button to turn the image stabilizer on or off.

- The (ON/OFF) mark appears in the viewfinder when the stabilizer is on.

### Notes:

- Overuse of the zoom may make recordings seem too busy. It is generally better to use it sparingly, or in order to reframe between shots.
- When you want to get as close as possible to your subject, keep the zoom at the wide-angle position. You can focus on a subject as close as 1 cm (3/8 in).
- Keep the image stabilizer turned off when the camera is mounted on a tripod.
- The image stabilizer always remains on when you are using the Easy Recording program (see p. 22).
- The image stabilizer is designed to deal with a normal degree of camera shake — it cannot compensate for large movements of the camera.
- The image stabilizer is not as effective as usual when the optional wide-converter or tele-converter is attached.

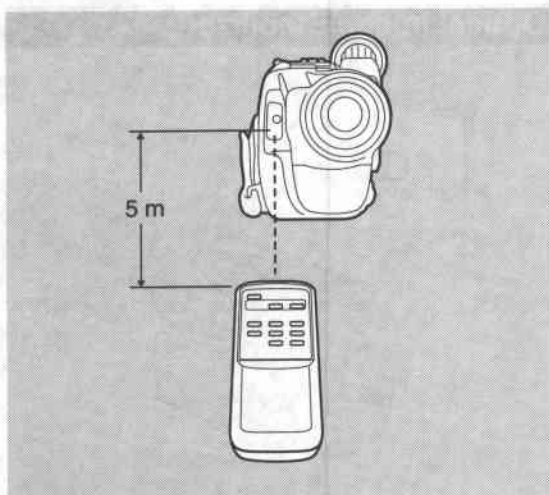

The wireless controller can operate the camera from a distance of up to 5 metres. Point it at the camera's remote sensor while you press the buttons.

The tally lamp lights up to let you know that the camera is in range and responding to your commands.

There are two functions which can only be operated using the wireless controller:

- Tape return (p.13)
- On-screen viewfinder displays (p. 37)

## Turning off the tally lamp and remote sensor

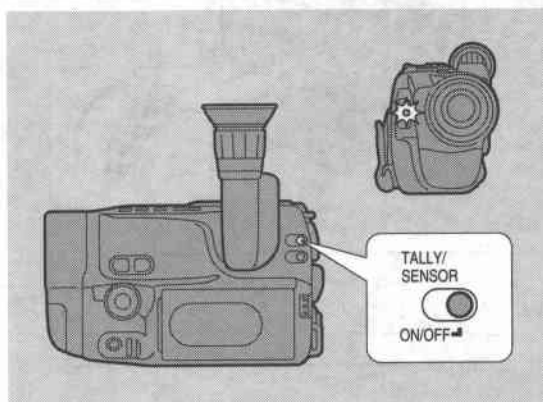

The tally lamp flashes continuously while the camera is recording. It can be turned off to prevent light being reflected into the lens during macro recording, or when shooting through glass.

Turning off the remote sensor prevents accidental operation by other Canon wireless controllers being used nearby.

1. **Press the TALLY/SENSOR ON/OFF button to turn off the tally lamp and the remote sensor.**
  - T/S OFF appears in the viewfinder.
2. **Press the button again to turn the lamp and sensor on.**

## Inserting batteries

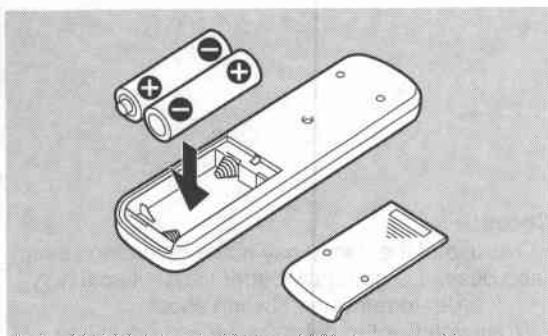

Insert two AA batteries, following the ⊕ and ⊖ markings. Be careful not to reverse the polarity of the batteries.

### Notes:

- Sunlight or fluorescent light falling on the sensor may shorten the controller's operating distance by interfering with its infrared signals.
- The camera may have difficulty picking up the remote control signals at extremely close range.
- Do not leave the controller exposed to direct sunlight, or in hot or humid places.
- When changing exhausted batteries, replace them all at once.

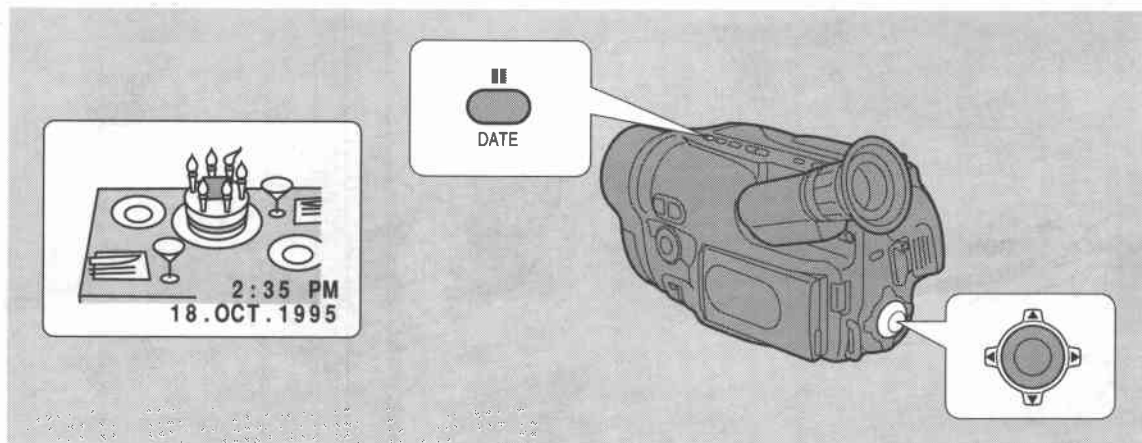

The date and/or time display appears in the viewfinder when you press the DATE button. If you start recording now, it will be superimposed on the scene. Press the button again to cancel the display.

If you have not set the date and time, —:—:— appears in the viewfinder when you press the DATE button. This will not be recorded.

## Setting the date and time

Set the date and time display when you first start using your camera. As long as you have installed the backup battery (p. 12), the camera's internal clock will continue to work even when the main power source is removed.

1. **Set the OPERATE switch to CAMERA.**
2. **Press and hold the DATE button for three seconds.**
  - The year display in the viewfinder starts flashing.
3. **Press the ▲ or ▼ side of the FlexiZone controller to scan the year display.**
  - Press once to scan a year at a time. Press and hold to scan quickly.
4. **When you have chosen the year, press the ◀ or ▶ side of the FlexiZone controller.**
  - The year is set, and the next part of the display starts flashing.
5. **Repeat steps 3 and 4 to set the months, days, hours and minutes.**
6. **Press the DATE button to start the clock.**

## Choosing the display style

You can choose from three different date/time displays:

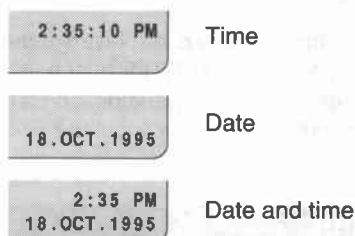

1. **Set the OPERATE switch to CAMERA.**
  2. **Press and hold the DATE button for one second.**
    - The following menu appears in the viewfinder:
- 
3. **Press the ▲ or ▼ side of the FlexiZone controller to choose the display style.**
    - Move the arrow so it is pointing at the display style you want to use.
  4. **Press the DATE button.**

**Note:**

- The display can be set to any year between 1995 and 2020.

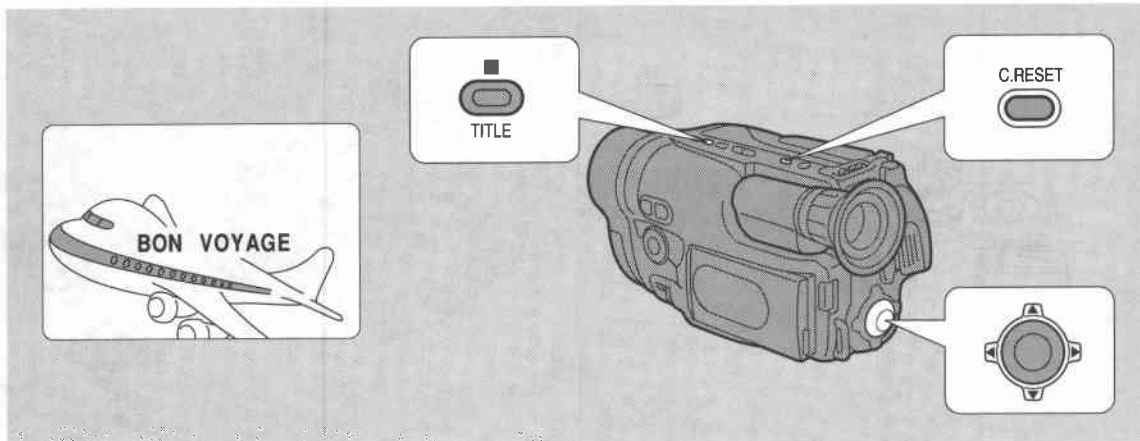

You can write your own titles and store them in the camera's memory in order to add them to your recordings. Remember to install the backup battery first (see p. 10).

The title stored in the memory is displayed in the viewfinder when you press the TITLE button. If you start recording now, it will be superimposed on the scene. Press the button again to cancel the display.

## Writing a title

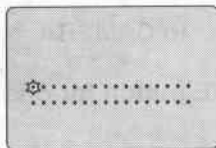

These lines appear in the viewfinder while you are writing a title.

Enter your title in the camera's memory before you start recording. The title can be one or two lines of up to 16 characters each.

1. **Set the OPERATE switch to CAMERA.**
2. **Press and hold the TITLE button until the title lines appear in the viewfinder.**
  - If you have already entered a title in the memory, it will be displayed in the viewfinder.
  - The first dot (or character) flashes to show where the cursor (the insertion point) is located.
3. **Press the ◀ or ▶ side of the FlexiZone controller to move the cursor to the point where you want to start the title.**
  - Press once to move the cursor one space at a time. Press and hold to move it quickly.

4. **Press the ▲ or ▼ side of the FlexiZone controller to scan the list of title characters.**

- Press once to scan one at a time. Press and hold to scan quickly.
- You can choose from the following characters:

→ ABCDEFGHIJKLMNOPQRSTUVWXYZ ←  
 → ⚡ & \* ! ? ; : ' " / . , 9 8 7 6 5 4 3 2 1 0 ⚡ Ë Ç Ñ Æ Å Ø Ù Ö Å ←

- If you choose the flashing dot ⚡, nothing will be recorded at this position.
- You can erase all the characters at and to the right of the cursor by pressing the C.RESET button.

5. **When the character you want is displayed, press the ◀ or ▶ side of the FlexiZone controller to move the cursor to the point where you want to write the next character.**
6. **Repeat steps 4 and 5 until your title is complete, then press the TITLE button to enter the title in the memory.**

### Note:

- If it takes you more than about five minutes to write a title, the camera may turn itself off automatically before you finish. This can be avoided by removing the cassette before you begin.

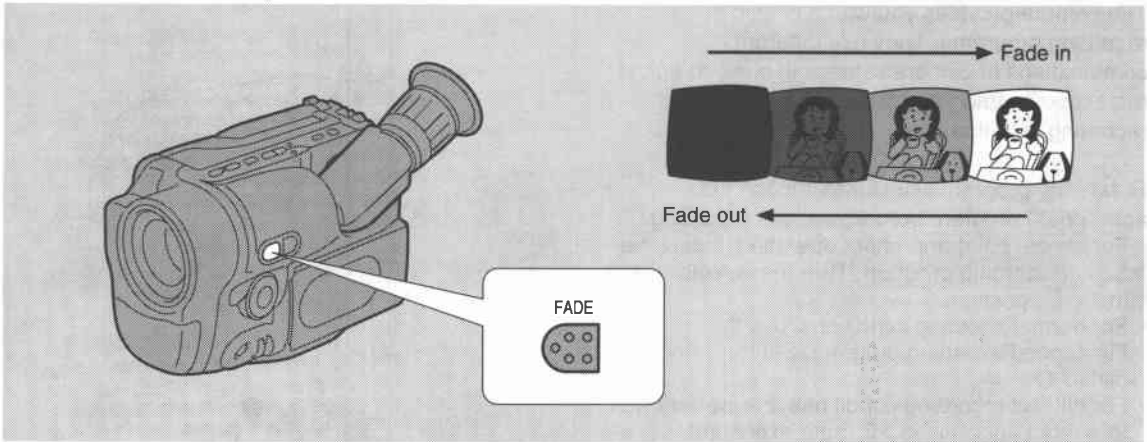

## Fade in

To make the scene gradually appear from a blank screen:

1. **Make sure the camera is in record pause mode.**
2. **Press and hold the FADE button until the scene disappears completely from the viewfinder.**
3. **Press the start/stop button to begin recording.**
4. **Release the FADE button.**
  - The scene gradually reappears in the viewfinder.

## Fade out

To make the scene gradually disappear:

1. **Press and hold the FADE button during recording.**
2. **When the scene has completely disappeared, press the start/stop button to end recording.**
3. **Release the FADE button.**

### Notes:

- The sound fades together with the image.
- Title and date and time displays do not fade.

# Choosing a Recording Program

The camera provides you with a choice of six recording programs. They use different combinations of camera settings in order to adjust the exposure and other functions to match the recording situation.

Rotate the program selector to choose the appropriate program before you start recording.

- For simple point-and-shoot operation, select the Easy Recording program. Turn the selector dial to the □ position.
- For normal shooting conditions, use the FlexiZone Recording program. Set the selector dial to ⊕.
- For difficult recording conditions, the camera has four more specialised AE (auto exposure) programs.

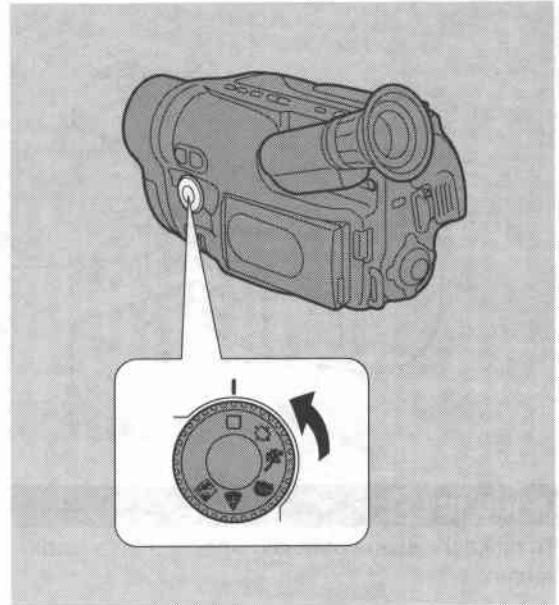

## Easy Recording

The simplest way to use the camera is with the program selector set to the □ position. The camera will adjust the focus and exposure automatically, leaving you free to point and shoot.



## FlexiZone Recording

In normal recording conditions, set the program selector to the ⊕ position. This is the same as the Easy Recording program, except that you now have the option of using any of the camera's manual functions.

- Choose this program if you want to use FlexiZone AF (p. 24), FlexiZone AE (p. 25), or the manual shutter (p. 26).

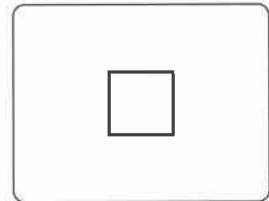

## Specialised AE programs

### Sports

This program is useful for recording high-speed sports scenes in brightly lit conditions. Normal playback will be slightly jerky, but you will get clear images which can be analysed frame by frame during slow or still playback on a VCR.



## Portrait

Use this program outdoors to make the subject stand out from a softened foreground and background. It works well for still-lives and close-ups. The effect is most noticeable when the zoom position is between the middle range and the telephoto end. Focus manually for maximum accuracy.



## Spotlight

This program is designed for recording spotlit scenes, such as on a stage. The exposure is automatically adjusted for glare-free recordings of subjects lit by a concentrated light source.



## Sand & Snow

Use this program in places where the background is so bright that the subject appears underexposed in the viewfinder — a sunny beach or ski resort, for example.



### Notes:

- Avoid changing programs during recording as the brightness of the image may change suddenly.
- The specialised AE programs are not suitable for all kinds of lighting. The image may flicker, or a bright line may appear on the screen if you use them in the wrong lighting conditions.

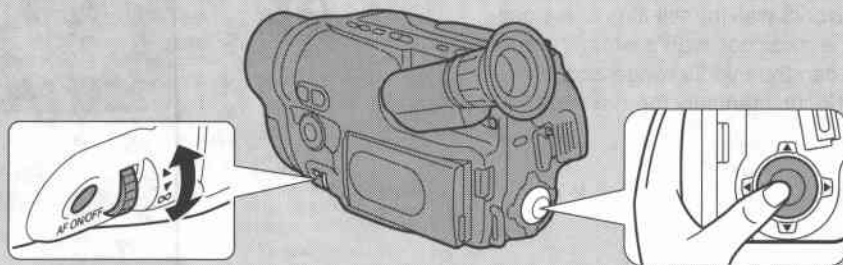

The camera can focus automatically. All you have to do is point it, and whatever is in the centre of the viewfinder will usually be in sharp focus.

It also has two functions which give you more control over focusing.

## FlexiZone AF

FlexiZone AF makes autofocus much more powerful. Using the FlexiZone controller, you can select any object that appears in the viewfinder, and the camera will bring it into focus. Choose the FlexiZone Recording program when you want to use FlexiZone AF.

FlexiZone AF is useful in the following situations:



When your main subject is not in the centre of the viewfinder



When you want to shoot a moving subject



It also makes it easy to use "focus shift" techniques. You can direct the viewer's attention by focusing first on one part of the scene, and then on another.



1. Turn the program selector to .

- The FlexiZone Control frame appears in the viewfinder.

2. Use the FlexiZone controller to move the frame over the subject.

- The controller can be moved in any direction. Press it repeatedly to move the frame little by little. Press and hold to move the frame quickly.
- The camera adjusts the focus to suit the area inside the frame.

## Manual focus

If the camera does not seem to be focusing well, it may be because the subject is not suitable for autofocus. In such cases, you can adjust the focus manually.

1. Use the zoom to frame your subject.

- If you use the zoom after focusing, the picture may go out of focus.

2. Press the AF ON/OFF button to switch from auto to manual focus.

- AF OFF appears in the viewfinder.
- The focus remains locked at the point set by autofocus.

3. Use the focus wheel to set the focus.

- Turn it downwards (towards  $\infty$ ) to move the focus further away. Turn it upwards to bring the focus nearer.
- It is also possible to use the focus wheel without turning autofocus off. In this case, autofocusing resumes as soon as you release the focus wheel.

4. Press the AF ON/OFF button again to return to autofocus.

### Notes:

- See "Troubleshooting" on p. 36 for a list of subjects which may not be suitable for autofocus.
- Manual focus is cancelled if you choose the Easy Recording program, or if you move the OPERATE switch from the CAMERA position.
- FlexiZone AF is cancelled if you move the program selector from the  position, or if you move the OPERATE switch from the CAMERA position.



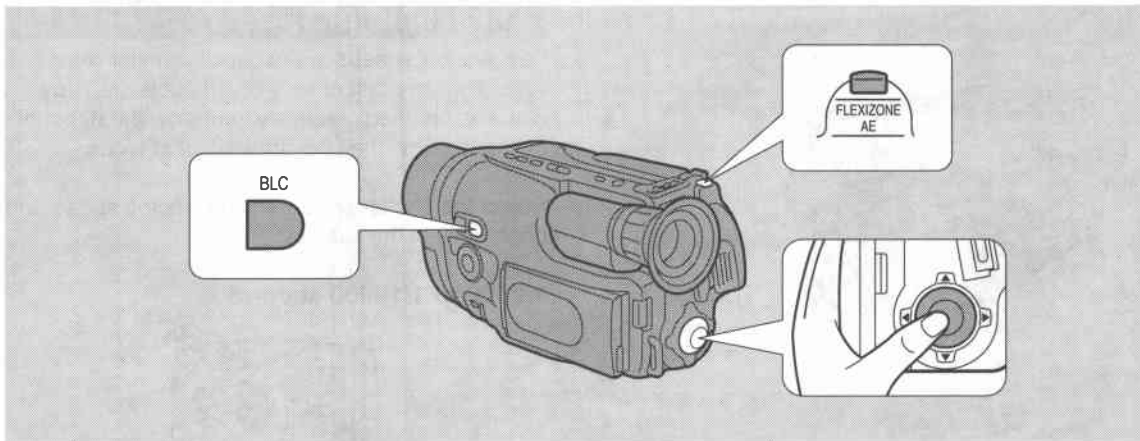

The camera adjusts the exposure automatically, making sure that your pictures are neither too dark or too light. There is a choice of six recording programs to deal with different recording conditions (see p. 22).

This section explains how to use two more exposure functions. These will give you added control over your recordings.

## Backlight compensation

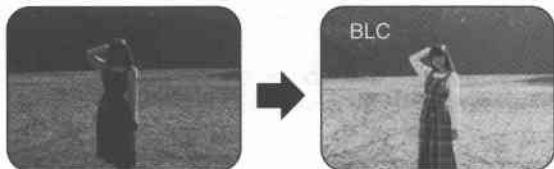

If the subject is brightly lit from behind, it may appear underexposed and lacking in detail. To compensate for this backlighting effect, press and hold the BLC button. Monitor the exposure in the viewfinder, and release the button when the compensation is no longer needed.

- You can only use backlight compensation when you have selected the Easy Recording or FlexiZone Recording program.

## FlexiZone AE

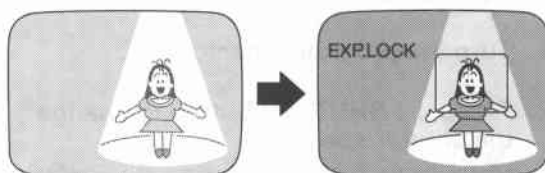

The camera usually adjusts the exposure so that it is suitable for the whole scene, and especially for the area in the centre of the viewfinder. FlexiZone AE allows you to choose any part of the scene, so that even if your subject is towards the edge of the screen, or if it is very bright or very dark, it will still be properly exposed.

1. **Turn the program selector to .**
  - The FlexiZone Control frame appears in the viewfinder.
2. **Use the FlexiZone controller to move the frame over the subject.**
  - The controller can be moved in any direction.
3. **Press the FLEXIZONE AE button.**
  - The camera adjusts the exposure to suit the area that is currently inside the frame. You can move the frame to focus on something else, but the exposure area will not move with it.
  - EXP.LOCK appears in the viewfinder.
4. **Press the button again when you want to cancel FlexiZone AE.**
  - The exposure is now adjusted to suit the centre of the screen again.
  - Press the button once more if you want to adjust the exposure for the frame's new position.

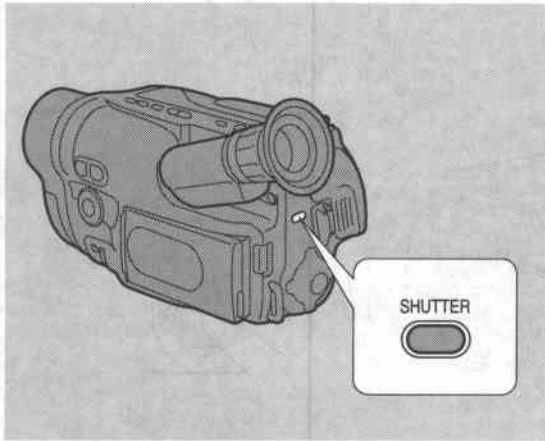

The shutter speed is usually set automatically, but you can also set it manually. You have a choice of eight different shutter speeds.

1. Turn the program selector to  $\square$ .
2. Press the SHUTTER button to change the shutter speed.
  - Each time you press the button, the viewfinder display changes as follows:

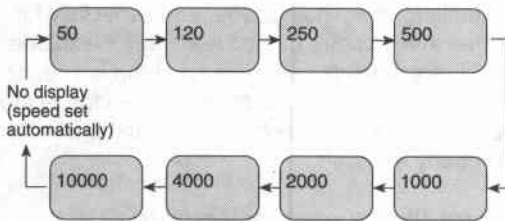

3. Make your recording.
4. Press the SHUTTER button again to return to the normal shutter speed.
  - The display disappears from the viewfinder.

## Which shutter speed?

Fast shutter speeds are especially useful when recording very fast or very bright subjects. They can also be used creatively to narrow the depth of field and throw the background out of focus.

Select the shutter speed which suits the speed and brightness of the subject:

### 1/2000 to 1/10000 second

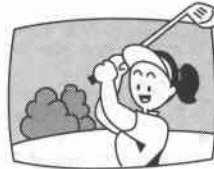

To record outdoor sports on a clear day so that you can freeze the action clearly. Normal playback will be slightly jumpy, but on a VCR with a noise-free still playback function, you will get clear images which can be analysed frame by frame.

### 1/250 to 1/1000 second

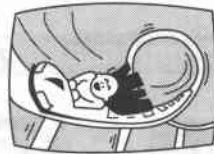

To record outdoor action on a cloudy day, or for a more stable picture when shooting from a moving car.

### 1/120 second



To reduce the exposure level when shooting very bright scenes, or to give more stable pictures when shooting indoor sports.

### Notes:

- The higher the shutter speed, the more light you will need.
- Make sure the sun does not appear in the viewfinder when the shutter speed is set to 1/1000 second or faster.
- The shutter setting is cancelled if you move the OPERATE switch from the CAMERA position, or if you move the program selector from  $\square$ .

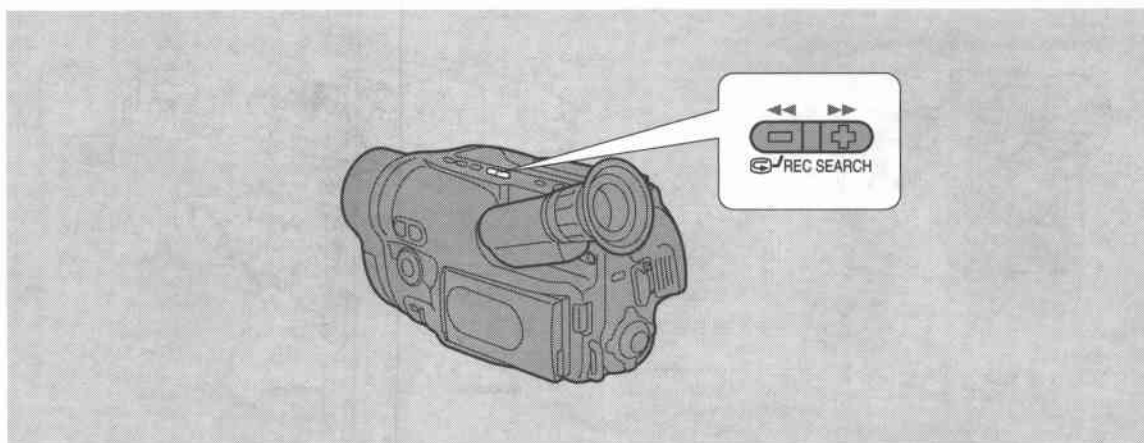

## Record search

When the camera is in record pause mode, you can use record search to play the tape forwards or backwards to find the point where you want to start or restart recording. This is useful when you want to add a new scene to a previously used cassette. By using record search, you can ensure a smooth, noise-free join between the new scene and the old one.

1. **Make sure the camera is in record pause mode.**
2. **Press and hold the REC SEARCH + or – button while you check the picture in the viewfinder.**
  - The + button plays the recording forwards and the – button plays it backwards.
3. **Release the button when you find the point where you want to start recording.**
  - The record search picture pauses briefly and then the camera returns to record pause mode.

## Record review

When the camera is in record pause mode, you can use record review to play back the last few seconds of your recording and then return automatically to record pause mode. You can quickly make sure that a scene has recorded properly and then go on to shoot the next scene, without producing any noise in the picture.

1. **Make sure the camera is in record pause mode.**
2. **Press and release the  button (the REC SEARCH – button) while you check the picture in the viewfinder.**
  - The camera rewinds the tape and plays back the last few seconds.
  - The camera returns to record pause mode at the point where you pressed the button.

### Note:

- Noise or skew (picture distortion) may appear on the screen during record search and record review.

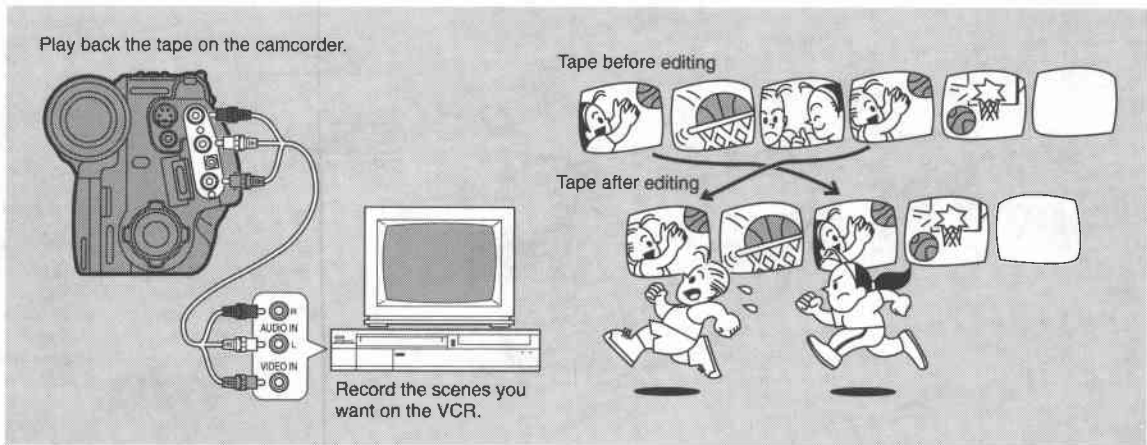

By connecting the camera to another VCR, you can edit your recordings in order to remove unwanted scenes — or combine different shots to create your own video production.

## Preparations

1. **Connect the camera to the VCR.**
  - See “Playback Connection” on p. 14.
2. **Turn the TV on.**
  - Be sure to set it to the video channel, or set the TV/VIDEO selector to VIDEO.
3. **Turn on the VCR and load a blank cassette.**
  - See your VCR instruction manual for details.
4. **Set the VCR’s input selector to LINE, and put it in record pause mode.**
5. **Set the camera’s OPERATE switch to PLAY, and load your recorded cassette.**

## Basic editing

1. **Find a point on your recorded cassette slightly ahead of the section you want to copy.**
2. **Start to play it back while you monitor the picture on the TV.**
3. **Start recording on the VCR as soon as the section you want to copy appears on the screen.**
4. **Pause the VCR at the end of the section you want to copy, then stop playback on the camera.**
5. **Repeat steps 1 to 4 until your edited recording is complete.**

## REMOTE terminal

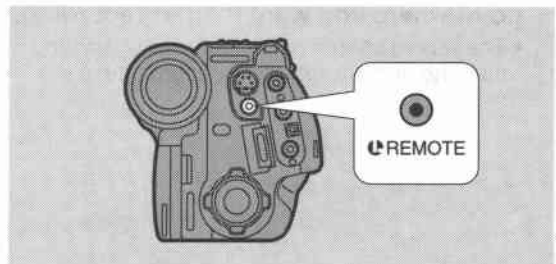

The  REMOTE terminal allows you to connect the camera to equipment such as the VE-100 Video Editor (p. 33). Some buttons on other editing equipment may operate differently from those on the camera.

### Notes:

- The quality of the edited tape will be slightly lower than that of the original.
-  (LANC) is a trademark. It stands for Local Application Control Bus System.

# Making Better Videos

## Holding the camera

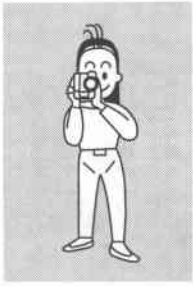

For maximum stability, place your right hand through the grip belt and keep your right elbow pressed against your body. Rest your left hand lightly on the side of the camera. With practice, you will be able to operate the controls by touch, without taking your eye off the action.

## Using a tripod

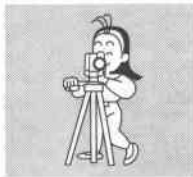

To prevent any unwanted movement, you can mount the camera on a tripod, and operate it with the wireless controller.

## Sound recording

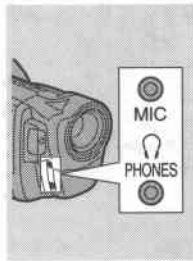

You can monitor the sound while recording by attaching stereo headphones to the camera's PHONES terminal.

For greater creative control, you can connect an external microphone to the MIC terminal.

## Composition



The most important element in the scene does not have to be in the centre. For a more interesting picture, try to position your subject so it is slightly to one side. Leave some space on the side of the frame that the subject is facing or moving towards.



Don't cut off the top of the subject's head, and don't cut people off at the neck, hips or knees (move a little bit above or below).



Watch out for distracting objects in the background.

## Picture angle



Long shot



Medium shot



Close-up

Instead of zooming while recording, try to choose your picture angle before you begin. A good way to tell a story with video is to begin with a long shot that establishes the situation, and then move in with medium shots and close-ups to show the details. Remember to change your viewpoint for each shot.

## Camera moves

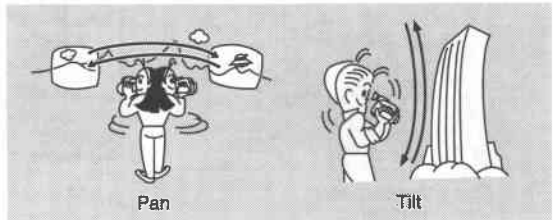

Pan

Tilt

Use pans to record a landscape or follow a moving subject. Decide the area you want to cover and stand facing the end of your panning angle. Without moving your feet, turn your waist to the starting position. Start recording, and after a few seconds begin to turn slowly from the waist. Hold the final image for a few seconds before you stop recording.

Tilt the camera up to exaggerate the height of the subject. Tilt down from the top of a building, for example, as an introduction to subjects at the bottom.

Remember that any camera movement or change in picture angle should have a definite purpose. Avoid unnecessary or half-hearted movements.

### Notes:

- When you are using a tripod, be careful not to leave the viewfinder exposed to bright sunlight or it will melt. (The light is concentrated by the viewfinder lens.)
- Make sure that the fastening screw of the tripod is no longer than 5.5 mm ( $\frac{3}{16}$  inch), or it will damage the camera.
- The camera has a built-in wind screen to prevent wind noise from interfering with the soundtrack. This has no effect when using an external microphone.

# UC8Hi Video System

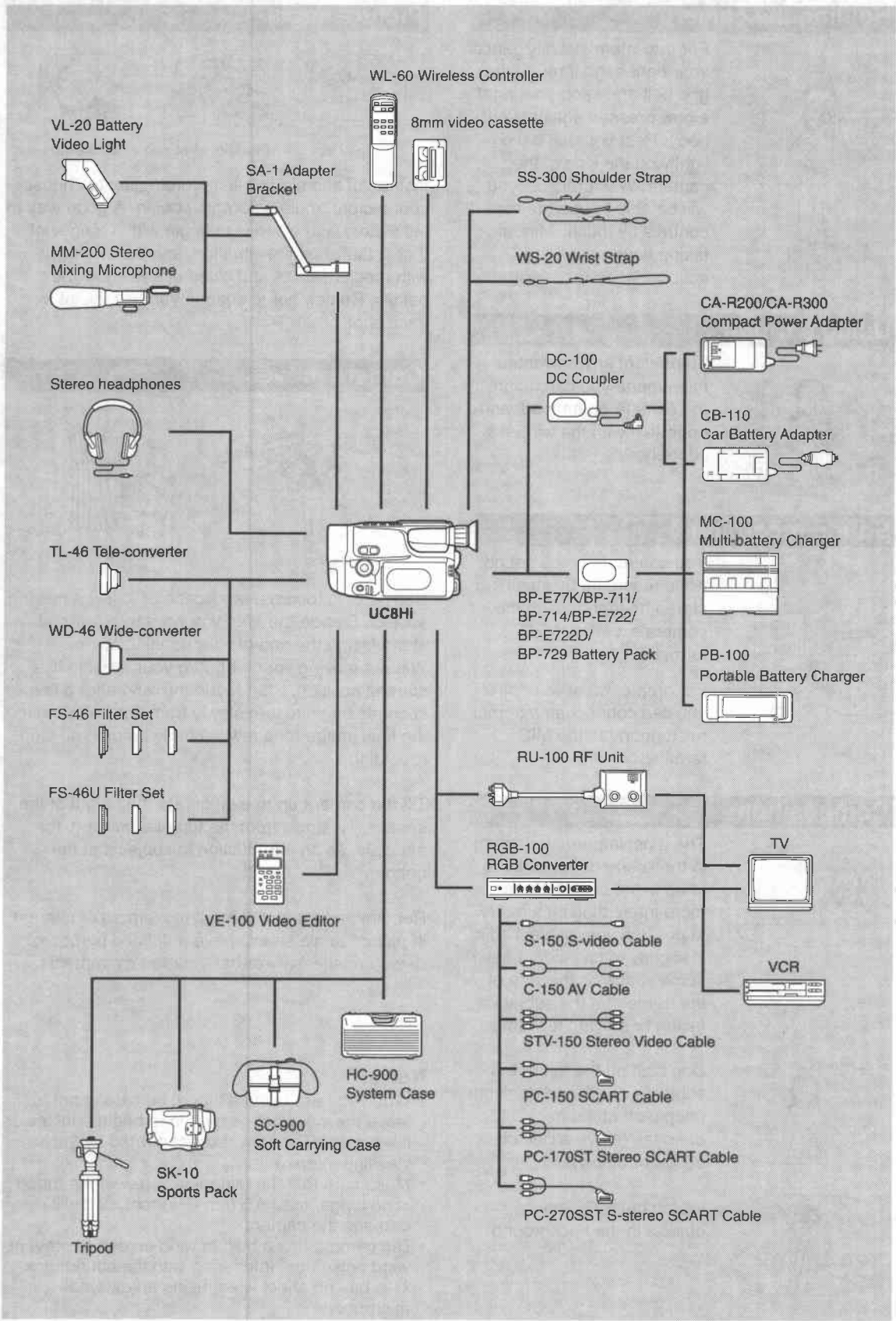

**30**  
 Additional Information

BP-711  
BP-E77K  
BP-714



BP-E722  
BP-729



BP-E722D



## Battery Packs

As well as the BP-E77K supplied with your camera, a whole range of optional battery packs is available.

Recording times are as follows:

BP-711/BP-E77K ..... 40 min.

BP-714 ..... 55 min.

BP-E722/E722D ..... 80 min.

BP-729 ..... 110 min.

The BP-E722D has a five-LED display which lets you know just how much charge you have left.

CB-110

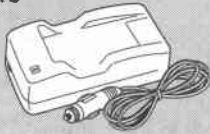

## CB-110 Car Battery Adapter

To power your camera or recharge battery packs on the move, the car battery adapter plugs into your car's cigarette lighter socket and runs off a 12/24 V negative ground battery.

MC-100

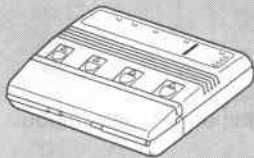

## MC-100 Multi-battery Charger

The microcomputer-controlled MC-100 takes up to four battery packs at a time and dramatically cuts recharge times (it can charge the BP-711/BP-E77K in just 45 minutes.) It also performs an automatic charge/discharge/recharge cycle which refreshes battery packs, restoring them to full capacity.

TL-46



## TL-46 Tele-converter

This tele-converter lens increases the focal length of the camera lens by a factor of 1.4. The zoom and autofocus operate as usual, so you can take full advantage of the extra range.

- If you have a "professional-type" monitor, there may be some vignetting.

WD-46



## WD-46 Wide-converter

This lens decreases focal length by a factor of 0.7, giving you a wide perspective for indoor shots or panoramic views — and you can still use both zoom and autofocus.

- If you have a "professional-type" monitor, there may be some vignetting.

FS-46

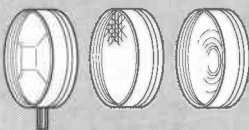

## FS-46 Filter Set

Three special effects filters to add a creative touch to your recordings: multiple-image, R-cross and zoom-spot.

- Turn autofocus off when using special effects filters.
- If you have a "professional-type" monitor, there may be some vignetting.

FS-46U

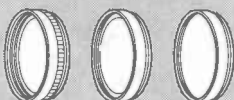

## FS-46U Filter Set

Ultraviolet, neutral density and circular polarising filters help you take control of difficult lighting conditions.

VL-20



### VL-20 Battery Video Light

This compact yet powerful video light can be used for both indoor and outdoor shooting. There are no cables — the BP-711/BP-E77K Battery Pack fits neatly inside, powering it for up to 15 minutes. For longer recordings, the BP-E722/BP-E722D and BP-729 give about 35 and 50 minutes' use respectively.

MM-200

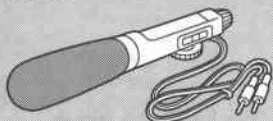

### MM-200 Mixing Microphone

The MM-200 mixes live sound and music, so you can create the ideal soundtrack for your video productions.

SA-1

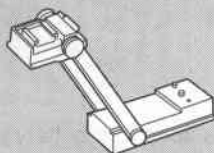

### SA-1 Adapter Bracket

Attaches a video light or microphone securely to the camera.

- The SA-1 cannot be attached to the camera when using the BP-E722/BP-E722D or BP-729 Battery Pack.

SC-900



### SC-900 Soft Carrying Case

This lightweight bag keeps the camera within easy reach without weighing you down or getting in the way.

WS-20



### WS-20 Wrist Strap

Provides an extra measure of protection for active shooting.

HC-900



### HC-900 System Case

This solid, lockable case provides safe and stylish protection for the camera during transportation and storage.



SK-10



### SK-10 Sports Pack

Completely waterproof your camera, while retaining control of its important functions. You can freely record active holidays at the beach, or on the ski slopes.

- The sports pack can be used underwater at depths of up to 3 metres. For safety reasons, it is designed to float, so it is best used close to the surface.

RU-100

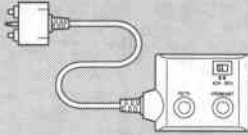

### RU-100 RF Unit

This optional converter allows the camera to be connected to the aerial terminal of any TV. It can be a useful accessory while travelling, as you may need it if you want to connect the camera to a TV in your hotel room.

VE-100



### VE-100 Video Editor

This easy-to-use editor controls the camera and a video recorder simultaneously for fast, accurate assembly editing. Not only does it link up to any L (LANC) terminal, it can even learn the remote control signals used by most VCRs.

RGB-100



### RGB-100 RGB Converter

Even without an S-video input, you can appreciate the difference Hi8 makes — the RGB-100 converts the camera's S-video signal to RGB, and links up with your TV's SCART terminal.



This mark identifies genuine Canon 8mm video accessories. When you use Canon 8mm video equipment, we recommend Canon-brand accessories or products bearing this same mark.

## Cautions

### Avoid high temperatures and high humidity.

- Do not leave the camera inside a car in hot weather, for example.
- Be careful of heat radiating from video lighting equipment.
- Do not take the camera into a humid room.

### Avoid sudden changes in temperature.

- If you take the camera from a cold place to a warm place, condensation may form on the lens and internal parts (see p. 35).

### Do not point the lens or viewfinder at strong light sources.

- Never point it at the sun, and do not leave it aimed at a bright subject.
- Be especially careful when leaving the camera on a tripod.

### Avoid magnetic or electric fields.

- Do not use the camera close to TV transmitters, portable communication devices or other sources of electric or magnetic radiation. They may cause picture interference, or permanently damage the camera.

### Do not expose the camera to water.

- Cover the camera when you are recording in light rain or mist.
- There is a risk of electric shock if water gets inside the camera — contact qualified service personnel as soon as possible.

### Protect the lens.

- Sand and dust can damage the lens — be especially careful on windy days.

### Handle the camera gently.

- Vibration or shock can cause damage.
- Do not use the viewfinder as a carrying handle.

### Do not disassemble the camera.

- This is very dangerous as there is a risk of electric shock — if the camera does not function properly, take it to qualified service personnel.

## Maintenance

### Viewfinder

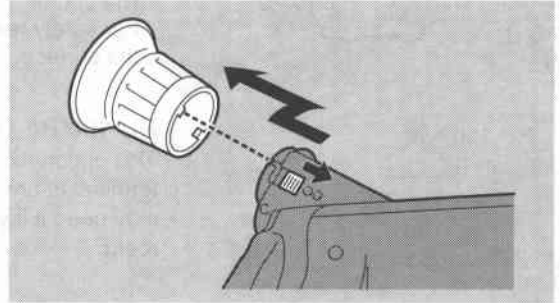

- Clean the viewfinder screen using a blower brush. First, remove the eyepiece: press and hold the RELEASE switch, pull the eyepiece out, turn it anticlockwise, and slide it off. To reattach it, align the mark on the eyepiece with the mark on its base and press it on until it clicks back into place.

### Camera body and lens

- Use a soft, dry cloth to clean the camera body or lens. Never use chemically treated cloth or volatile solvents such as paint thinner.

### Video heads

- Clean the video heads only when necessary, preferably using Canon's CC-8 Video Head Cleaning Cassette.
- Do not use a wet-type cleaning cassette as this can cause damage.

## Storage

If you do not intend to use the camera for some time, store it in an area which is free of dust and moisture, and where the temperature is no higher than 30°C (86°F). After storage, check each part and function of your camera to make sure everything is still working properly.

### Note:

- These cautions also apply to accessories such as battery packs and cassettes.

## Condensation

Condensation may form on the camera when it is moved from a cold place to a warm place. Using the camera while condensation is present can damage both the tape and the camera.

Condensation may become a problem:

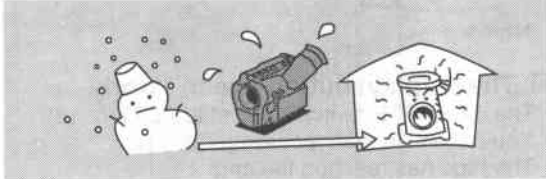

When you bring the camera from a cold place to a warm room

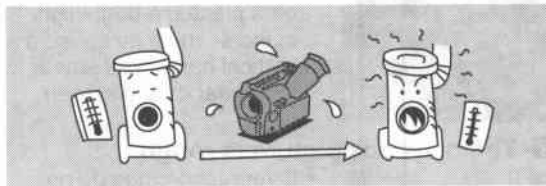

When a cold room is heated rapidly

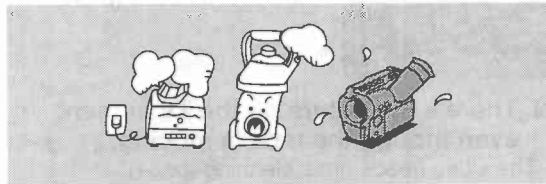

When the camera is left in a humid room

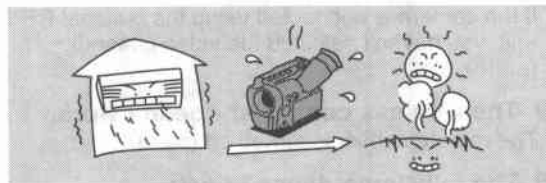

When the camera is taken from an air-conditioned room to a warm, humid place

### Protecting the camera from condensation

- Before you bring the camera to a warm or humid place where condensation is likely to be a problem, unload the cassette and put the camera in a plastic bag. Wait until the camera reaches room temperature before you take it out of the bag.

### What happens when condensation is detected

- The operation indicator flashes and the  mark flashes in the viewfinder. If there is a cassette in the camera, it stops automatically and EJECT flashes in the viewfinder.
- The camera may not detect the condensation immediately — the condensation warning may not start flashing for 10 to 15 minutes.
- You cannot load a cassette when condensation is detected.

### What you should do

- Remove the cassette, leave the cassette compartment open, and turn the camera off.
- Leave it in a dry place until the condensation evaporates. After the condensation warning stops flashing, wait at least another hour before trying to use the camera.

## Using the camera abroad

### Power sources

- You can use the compact power adapter to operate your camera and charge battery packs in any country where the electricity supply is between 100 and 240 V AC, 50–60 Hz. Contact your Canon dealer for information about plug adapters for overseas use.

### TV playback

- Although you can always play back your recordings in the viewfinder, your camera can only be connected to TVs which use its PAL system. This TV system is used in the following countries:  
Algeria, Australia, Austria, Bangladesh, Belgium, Brunei, China, Denmark, Finland, Germany, Hong Kong, Iceland, India, Indonesia, Ireland, Italy, Jordan, Kenya, Kuwait, Liberia, Malaysia, Malta, Mozambique, the Netherlands, New Zealand, North Korea, Norway, Oman, Pakistan, Portugal, Qatar, Sierra Leone, Singapore, South Africa, Spain, Sri Lanka, Swaziland, Sweden, Switzerland, Tanzania, Thailand, Turkey, Uganda, United Arab Emirates, United Kingdom, Yemen, former Yugoslavia, Zambia.

# Troubleshooting

Refer to this checklist first if you have any problems with your camera. Possible explanations are given below each problem on the list — turn to the page numbers in brackets for more information.

Make sure that the camera is properly connected if you are using it with a TV or VCR. Consult your dealer or service outlet if problems persist.

## ❑ Nothing happens when I press the buttons.

- You haven't turned the camera on (p. 6, 13).
- You haven't loaded a cassette, or it is set for erasure prevention (p. 11).
- The tape has reached the end.
- The battery pack is exhausted, or not properly attached (p. 9, 10).
- You need to select a different recording program to use that function (p. 22).

## ❑ The camera turned itself off.

- You left it in record pause mode for more than about five minutes (p. 6).
- The battery pack is exhausted (p. 9, 10).

## ❑ The start/stop button doesn't work.

- The OPERATE switch isn't set to CAMERA (p. 6).
- The STANDBY cover is closed (p. 6).
- You haven't loaded a cassette, or it is set for erasure prevention (p. 11).
- The tape has reached the end.

## ❑ There's no picture in the viewfinder.

- The OPERATE switch isn't set to CAMERA (p. 6).
- The STANDBY cover is closed (p. 6).

## ❑ The camera won't focus.

- The viewfinder lens needs adjusting (p. 12).
- The lens is dirty (p. 34).
- Some subjects are not suitable for autofocus. In the following situations, you will often get better results using manual focus (p. 24).



Subjects with horizontal stripes



Several subjects in the viewfinder at different distances



Subjects behind glass



Subjects without much contrast (such as a white wall)



Subjects which reflect too much light (such as shiny car exteriors)



Rapidly moving subjects



Slanted subjects



Dark subjects



Night scenes

## ❑ The ► (play) button doesn't work.

- The OPERATE switch isn't set to PLAY (p. 13).
- You haven't loaded a cassette (p. 11).
- The tape has reached the end.

## ❑ There's a bright stripe on the screen.



- When you are recording in dark places, a bright light in the scene may cause a vertical bar, called smear, to appear on the screen.

## ❑ The playback picture is rough.



- If your recordings do not play back smoothly, clean the video heads (p. 34).

## ❑ There's no picture on the TV screen, even though the tape is moving.

- The video heads need cleaning (p. 34).
- The TV/VIDEO selector on the TV isn't set to VIDEO (p. 15).
- If the camera is connected using the optional RF unit, you haven't selected the video channel (p. 16).

## ❑ The wireless controller doesn't work.

- The remote sensor is turned off (p. 18).

## ❑ The tally lamp doesn't flash.

- It is turned off (p. 18).

## ❑ The power indicator is flashing.

- Check the viewfinder displays (p. 37).

## ❑ There are air bubbles inside the lens.

- This is unlikely, but may happen if you use the camera in places where the air pressure is very low, in an aeroplane for example. The bubbles will disappear a week or so after you return the camera to normal atmospheric pressure.

## ❑ Malfunction



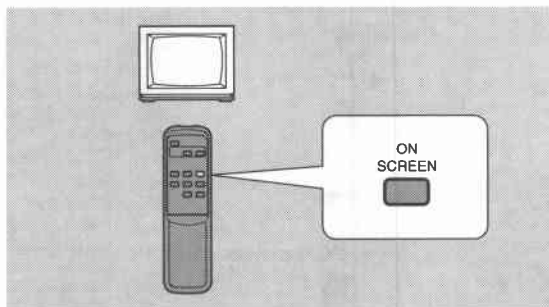







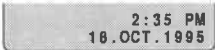

- External interference may cause the camera's microprocessor to malfunction temporarily. If random letters appear in the viewfinder or if normal operation is interrupted, remove and then replace the power source (and if necessary, the backup battery).

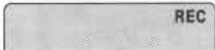

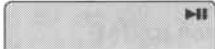
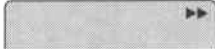









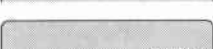

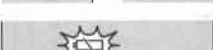
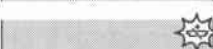



To display the date and time on a connected TV, press the DATE button. Press the TITLE button to see the title. These displays are recorded just as they appear on the screen.

Use the wireless controller's ON SCREEN button to choose whether or not the other viewfinder displays appear on the TV screen. They will disappear from the screen if you start recording with the camera.

 indicates a flashing display.

-  Date and time display (p. 19)
-  Date and time menu (p. 19)
-  Title (p. 20)
-  Record pause mode (p. 6)
-  Recording (p. 6)
-  Record search, forward and reverse (p. 27)
-  Playback (p. 13)
-  Still playback (p. 13)
-  Fast forward (p. 13)
-  Fast forward playback or high-speed search (p. 13)
-  Rewind (p. 13)
-  Rewind playback or high-speed search (p. 13)
-  The tape is stopped (p. 13).
-  The camera is ejecting the tape (p. 11).
-  The safety mechanism is activated. Unload the cassette and turn the camera off. Turn it on again and reload the cassette.

-  Tape speed (p. 11)
-  No cassette is loaded, or the cassette is set for erasure prevention (p. 11).
-  Hi8 recording (p. 11)
-  The tape has reached the end.
-  Tape return, forward and reverse (p. 13)
-  The battery pack is nearly exhausted (p. 8, 9).
-  The backup battery is nearly exhausted, or not inserted properly (p. 10).
-  Zoom display (p. 17)
-  The image stabilizer is turned on (p. 17).
-  The tally lamp and remote sensor are turned off (p. 18).
-  Specialised AE programs (p. 22)
-  Autofocus is turned off (p. 24)
-  FlexiZone Control frame (p. 24, 25)
-  FlexiZone AE (p. 25)
-  Backlight compensation (p. 25)
-  Shutter speed (1/1000th of a second in this example) (p. 26)
-  Condensation warning (p. 38)
-  **Tape counter**  
The tape counter indicates the approximate running time of the tape — 1 hour, 23 minutes and 45 seconds (in SP mode) in this example. The tape counter is reset when a cassette is loaded, or when you press the COUNTER RESET button (p. 13).

## Recording reminder



When you start recording, the camera counts from 0SEC to 10SEC. Shots which are shorter than 10 seconds may be difficult to edit later. On the other hand, if you are not planning to edit the recording, remember that a shot which does not contain action should generally last no longer than 10 seconds.

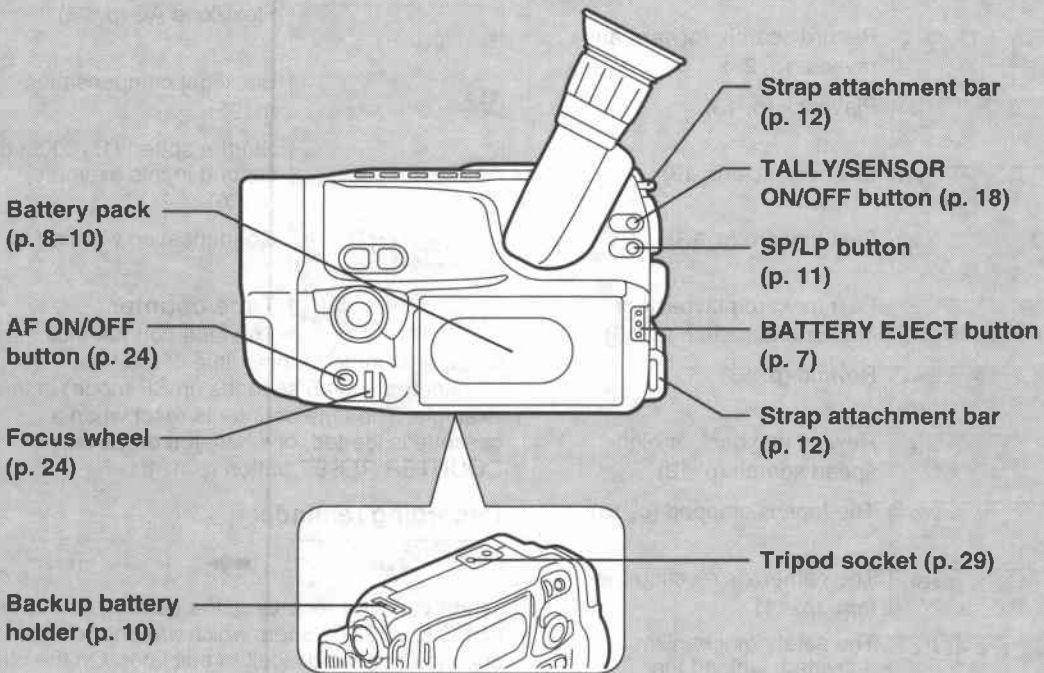
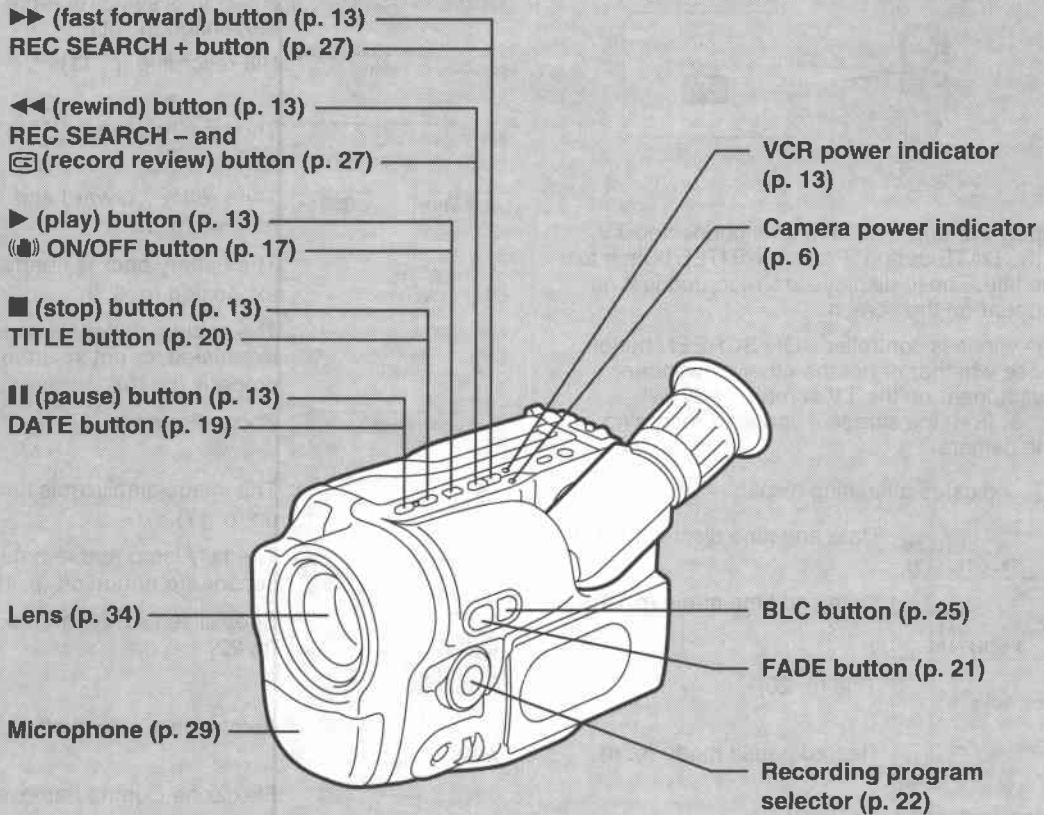

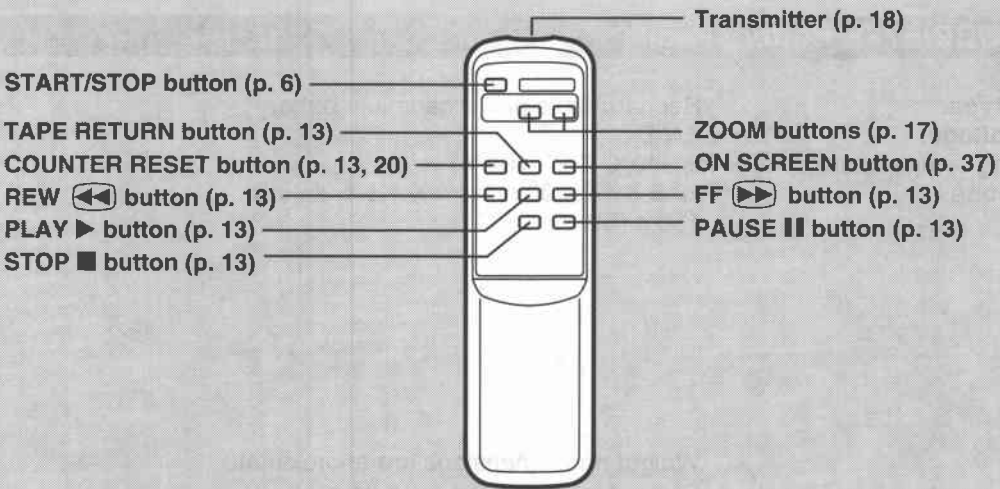
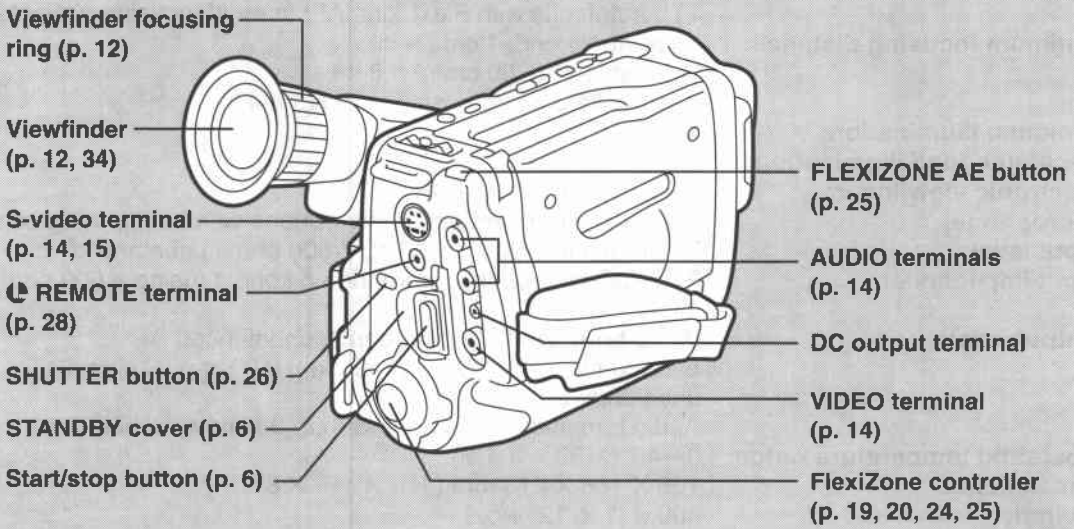
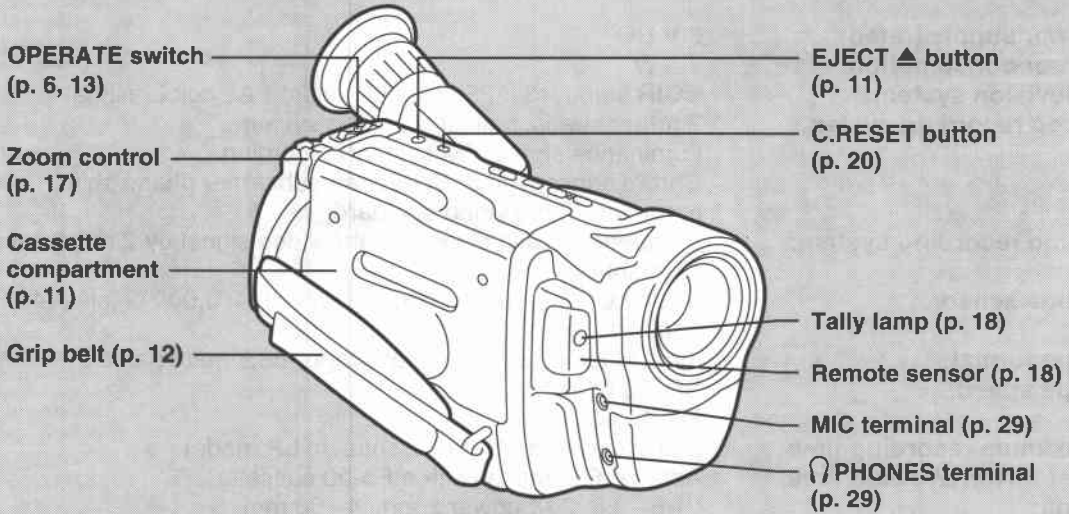

# Specifications

**E**

## UC8Hi

<b>Power supply (rated):</b>	6 V DC
<b>Power consumption:</b>	7.3 W
<b>Television system:</b>	CCIR standard (625 lines, 50 fields) PAL colour signal
<b>Video recording system:</b>	2 rotary heads, helical scanning system Luminance signal: FM azimuth recording Chrominance signal: Converted subcarrier phase shift recording (8mm video standard)
<b>Audio recording system:</b>	Frequency multiplexing with the video signal by 2 rotary heads (2 channels)
<b>Image sensor:</b>	¼-inch CCD (charge-coupled device), 470,000 pixels (440,000 effective pixels)
<b>Tape format:</b>	8mm video cassette, metal evaporated/metal particle
<b>Tape speed:</b>	SP: 20.05 mm/s LP: 10.03 mm/s
<b>Maximum recording time:</b>	3 hours (with a P5-90 cassette, in LP mode)
<b>Fast forward/rewind time:</b>	Approx. 6 minutes (with a P5-90 cassette)
<b>Lens:</b>	f/1.6–3.6, 20X power zoom, 4–80 mm TTL autofocus with FlexiZone AF; manual focusing possible
<b>Minimum focusing distance:</b>	Wide-angle end: 1 cm (¾ in) Telephoto end: 80 cm (2 ft 8 in) Intermediate zoom position: 1 m (3 ft 4 in)
<b>Minimum illumination:</b>	3 lx
<b>Recommended illumination:</b>	More than 100 lx
<b>Electronic viewfinder:</b>	½-inch monochrome CRT
<b>Microphone:</b>	Stereo electret condenser microphone with built-in wind screen
<b>Input level:</b>	External microphone: –67 dBV/600 ohms unbalanced
<b>Input impedance:</b>	External microphone: more than 6 kohms (using a 600 ohm mic)
<b>Output level:</b>	Video terminal: 1 Vp-p/75 ohms, unbalanced S-video terminal: 1 Vp-p (Y signal), 0.3 Vp-p (C signal), unbalanced Audio terminal: –10 dBV, less than 3 kohms, unbalanced
<b>Operating temperature range:</b>	0°–40°C (32°–104°F)
<b>Dimensions:</b>	106 X 106 X 213 mm (4 <sup>3</sup> / <sub>16</sub> X 4 <sup>3</sup> / <sub>16</sub> X 8 <sup>3</sup> / <sub>8</sub> in)
<b>Weight:</b>	800 g (1 lb 12 <sup>3</sup> / <sub>16</sub> oz)

## BP-711/BP-E77K Battery Pack

<b>Battery type:</b>	Rechargeable nickel cadmium battery
<b>Rated voltage:</b>	6 V DC
<b>Operating temperature range:</b>	0°–40°C (32°–104°F)
<b>Dimensions:</b>	22.5 X 47 X 90 mm (7 <sup>7</sup> / <sub>8</sub> X 1 <sup>7</sup> / <sub>8</sub> X 3 <sup>5</sup> / <sub>8</sub> in)
<b>Weight:</b>	150 g (5 <sup>1</sup> / <sub>4</sub> oz)

Weight and dimensions are approximate  
Errors and omissions excepted.  
Subject to change without notice.



- A**
  - Abroad, Using the Camera, 35
  - Accessories, 3, 31
  - Adapter, Mains, 7, 10
  - AE Programs, 22
  - Audio/Video Terminals, 14
  - Autofocus, 24
- B**
  - Backlight Compensation, 25
  - Backup Battery, 10
  - Basic Recording, 6
  - Battery Pack, 8–10
- C**
  - Cables, 3, 14
  - Cassettes, 11
  - Cautions and Maintenance, 34
  - Charging the Battery Pack, 9, 10
  - Cleaning the Camera, 34
  - Compact Power Adapter, 7, 10
  - Condensation, 35
  - Connection to TV or VCR, 14, 28
- D**
  - Date and Time Display, 19
  - DC Coupler, 7
  - Discharging the Battery Pack, 10
- E**
  - Easy Recording, 22
  - Editing, 28
  - Erasure Prevention, 11
  - Exposure Control, 25
  - Exposure Programs, 22
- F**
  - Fade, 21
  - Fast Forward/Fast Forward Playback, 13
  - Feedback, 14
  - FlexiZone AE, 25
  - FlexiZone AF, 24
  - FlexiZone Control Frame, 24, 25
  - FlexiZone Recording, 22
  - Focusing, 24
- G**
  - Grip Belt, 12
- H**
  - Head Cleaning, 34
  - Hi8, 11
  - High-Speed Search, 13
- I**
  - Image Stabilizer, 17
  - Introducing the UC8Hi, 4
- L**
  - LANC, 28
  - Lens Cap, 12
  - Lithium Battery, 10
  - Loading Cassettes, 11
  - LP, 11
- M**
  - Maintenance, 34
  - Making Better Videos, 29
  - Manual Focus, 24
  - Manual Shutter, 26
  - Microphone, 29
- N**
  - Nomenclature, 38
- O**
  - Optical Image Stabilizer, 17
  - Optional Accessories, 31
- P**
  - Pause, Record, 6
  - Playback, 13
  - Playback Connection, 14
  - Portrait, 23
  - Power Sources, 7
  - Preparing the Camera, 12
  - Problems, 36
- R**
  - Recharging the Battery Pack, 8, 9
  - Recording, 6
  - Recording Programs, 22
  - Record Pause Mode, 6
  - Record Review, 27
  - Record Search, 27
  - Refreshing the Battery Pack, 10
  - Remote Sensor, 18
  - Rewind/Rewind Playback, 13
- S**
  - Sand & Snow, 23
  - Shoulder Strap, 12
  - Shutter Speeds, 26
  - SP, 11
  - Specialised AE Programs, 22
  - Specifications, 40
  - Sports, 23
  - Spotlight, 23
  - Still Playback, 13
  - Storage, 34
- T**
  - Tally Lamp, 18
  - Tape Counter, 13, 37
  - Tape Return, 13
  - Tape Speed, 11
  - Telephoto, 17
  - Temperature, 9, 34
  - Time Display, 19
  - Titles, 20
  - Tripod, 29
  - Troubleshooting, 36
  - TV, 14
- U**
  - UC200 Video System, 30
  - Using the Camera Abroad, 35
- V**
  - VCR, 28
  - Video Cassettes, 11
  - Video Channel, 16
  - Viewfinder, 12, 34
  - Viewfinder Displays, 37
- W**
  - Wide-angle, 29
  - Wireless Controller, 18
- Z**
  - Zooming, 17





# Canon

**CANON INC.** 30-2, Shimomaruko 3-chome, Ohta-ku, Tokyo 146, Japan

**Canon Europa N.V.**

P.O. Box 2262, 1180 EG Amstelveen, the Netherlands

**Canon UK Ltd.**

Camera Division, Units 4 & 5, Brent Trading Centre, North Circular Road, Neasden, London NW10 0JF, United Kingdom,  
Telephone 0181-459-1266

**Canon Australia Pty. Ltd.**

1 Thomas Holt Drive, North Ryde, N.S.W. 2113, Australia,  
Telephone 805-2000, Fax 887-4484

**Canon New Zealand Ltd.**

Fred Thomas Drive, Takapuna, P.O. Box 33-336, Auckland, New Zealand,  
Telephone 486-1570, Fax 486-6420

**Canon Singapore Pte. Ltd.**

79 Anson Road #09-01/06, Singapore 079906,  
Telephone (65)-532-4400, Fax (65)-221-2939

**Canon Hongkong Co., Ltd.**

10/F, Mirror Tower, 61 Mody Road, Tsimshatsui East, Kowloon, Hong Kong

**Canon Latin America, Inc.**

Sales & Enquiries: P.O. Box 7022, Panama 5, Republic of Panama  
Service Department: P.O. Box 2019, Colon Free Zone, Republic of Panama



Printed on 70%  
reused paper.