

# Hotpoint Service and Spares

**FOR SERVICE:** If you have a problem with your appliance ring your local Service Office.  
**FOR SPARES and ACCESSORIES:** To purchase spares and accessories send your Accessories Order Form to your Spares Centre. If the accessory or spare part you want is not on the form, contact your Spares Centre for prices and availability.  
 Please address all correspondence to Hotpoint Spares Centre or Hotpoint Service Office as applicable.

Service Offices and Spares Centres are open between 8.00am-5.00pm Monday to Friday, except on Public Holidays. 8.30am-12.30pm on Saturdays.

- Service Office and Spares Centre
- Service Office only

## EAST

**ESSEX:** Industrial Buildings, Beehive Lane, Chelmsford, CM2 9TF.  
 Post Codes RM & IG Tel: (0245) 482433  
 Remainer of Essex Tel: (0245) 289331  
**PETERBOROUGH:** Chula Road, PE2 9JL. Tel: (0753) 64741  
 Spares Administration Dept. Tel: (0753) 555520

## LONDON

**WEMBLEY:** 68 East Lane, HA9 7PD. Tel: 081-904 4939  
 S. Herts and Middlesex. Tel: 081-908 4122  
 Post Codes N, NW, E, EC. Tel: 081-908 4122  
 Post Codes W, WC, SE, SW. Tel: 081-908 2511  
 Tel: 081-904 0201

## MIDLANDS

**BIRMINGHAM:** Westgate, Aldridge, W Midlands, WS9 8UX.  
 Post Codes B Tel: (0922) 743374  
 All other Post Codes Tel: (0922) 743376  
 Tel: (0922) 743377

## NOTTINGHAM

**STOKE:** Ashing Street, NG2 3JB. For Spares Tel: (0602) 980387  
 Tel: (0602) 982481/9864322  
 West Ave, Nelson Estate, Talke, ST7 1TN. Tel: (0782) 774511

## NORTH EAST

**WASHINGTON:** 8 Beale House, Tower Road, Glover Est. District 11, NE37 2SH.  
 Tel: 091-417 3500/419 3535  
 Sandbeck Lane, LS22 4TW.  
 Tel: (0937) 981261/981444 For Spares Tel: (0937) 981221

## WETHERBY:

For Service

## NORTH WEST

**KENDAL:** Muntford House, 26 Highgate, LA9 4SX. Tel: (0539) 724483  
 44/46 Station Road, Heaton Mersey, Stockport, SK4 3OT.  
 Manchester North Tel: 061-432 0513  
 Manchester South Tel: 061-442 8677  
 Tel: 061-432 0255

## NETHERTON:

For Spares  
 7 Bridge Way, Messyaside. Tel: 051-525 2342/524 2339

## SCOTLAND

**ABERDEEN:** Holbeck House, 88 Garden Place, AB1 1UL. Tel: (0224) 642283  
 35 West Bowling Green Street, Leith, EH6 5NX. Tel: 031-554 1431  
 West Lodge Road, Blythswood Estate, PA4 9FN.  
 Tel: 041-866 8241 For Spares Tel: 041-866 8611

## SOUTH

**KENT:** Larkfield Trading Est, New Hythe Lane, Larkfield, ME20 6SW.  
 CT DA ME & TN Kent Post Codes Tel: (0622) 716570  
 CR, KT, RH, SM, Surrey & BR Kent Post Codes (0622) 790707  
 6U Post Codes in Surrey Tel Southampton (0703) 667374  
 Tel: (0622) 716631

## SOUTHAMPTON:

For Spares  
 Unit R, S, Hamptonia Ind Park, Salisbury Rd, Totton, SO40 3SA.  
 Tel: (0703) 861987/867374 For Spares Tel: (0703) 867933  
 1 Kingswood, North St, Halesham, BM27 1DD. Tel: (0323) 842733  
 69 Mulvey Plain, PL4 6JH. Tel: (0752) 262531

## WALSLEY:

For Service  
 Conwy Rd, Llandudno Junction, LL31 9NE. Tel: (0492) 573536  
 18 Western Ave, Bridgend Ind. Estate, Bridgend, CF31 3SL.  
 Post Codes CF, SA & SY23-25 Tel: (0656) 664121  
 Post Codes BS, GL, (Ind 55), HR, SY15-18, LD1-8, NP. Tel: (0656) 655554  
 Tel: (0656) 768111

## IRELAND

**NORTHERN:** 256 Ormeau Road,  
 Belfast, BT7 7FZ.  
 Tel: (0232) 647111  
 49 Airways Ind. Estate,  
 Dublin 17.  
 Tel: Dublin 426088  
 Tel: Dublin 426938

## EIRE:

For Service  
 For Spares

## CHANNEL ISLANDS

Normal Guarantees apply and all Service Schemes are available.

## JERSEY:

19 Don Street, St. Helier  
 Tel: (0534) 21625  
 Clos D'Ormes, Portlet,  
 St. Clements. Tel: (0534) 54808

## GUERNSEY & SARK:

Valpys Stores, Grande Rue, St. Martins,  
 Guernsey. Tel: (0481) 38422  
 or  
 Barras Lane, Vale,  
 Tel: (0481) 51610  
 32 High Street,  
 Tel: (0481) 822686

## ALDERNEY:

For Service

## ISLE OF MAN

Normal Guarantees apply and all Service Schemes are available

From 5 Dunnington St., Douglas.  
 Tel: (0624) 673233  
 or  
 Tromode Works,  
 Cronkbourne Village, Douglas.  
 Tel: (0624) 676066  
 17 Ridgeway Street, Douglas,  
 Tel: (0624) 25811/25848

## SHETLAND, ORKNEY & WESTERN ISLES

Service provided by Agents. Normal Guarantees apply, but Service Schemes are NOT available.

## SHETLAND:

Fort Road, Lerwick  
 Tel: (035) 2557

## ORKNEYS:

Hairstone Ind Estate, Kirkwall  
 Tel: (0856) 5457

## WESTERN ISLES:

27 Bayhead Street,  
 Stromway, Isle of Lewis  
 Tel: (0851) 3387

## OTHER ISLANDS:

Local Hydro Electric Shops

## EXCEPT ARRAN, BUTE & SKYE

Which are covered by Hotpoint.

# HOTPOINT HANDBOOK

## FREEZERS

### MODELS 8732, 8742

### AND 8764

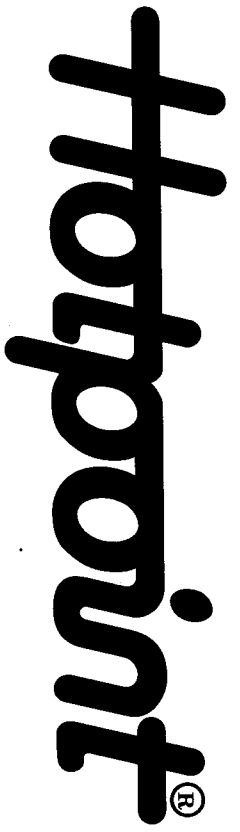

In accordance with its policy of progressive product design, the Company reserves the right to alter specifications.  
 Hotpoint Ltd, Peterborough, PE2 9JL, England  
 2251271738

# Your new Hotpoint Freezer

Using your new freezer is very simple. Nevertheless, for your own safety and to get the best results it is important that you read right through this handbook **before** using your freezer for the first time.

Also do not load your freezer immediately it is switched on, but wait until the correct storage temperature has been reached (see page 9).

## ELECTRICAL REQUIREMENTS

We recommend that this appliance is connected to the mains supply via a suitable switched socket in a readily accessible position.

All Hotpoint appliances come complete with a fitted plug. The plug on your freezer has a 13A fuse. If the plug does not fit your sockets, a new plug can be fitted. Cut off the old plug and throw it away, do not insert it into a socket elsewhere in the house as this could cause a shock hazard.

**WARNING: THIS APPLIANCE MUST BE EARTHED.**

**IMPORTANT: Fitting a Different Plug:**

The wires in the mains lead are coloured in accordance with the following code:

- Green and Yellow – Earth
- Blue – Neutral
- Brown – Live

If you fit your own plug the colours of these wires may not correspond with the identifying marks on the plug terminals. This is what you have to do:

1. Connect the green and yellow (Earth) wire to the terminal in the plug marked 'E' or with the symbol  $\oplus$ , or coloured green or green and yellow.
2. Connect the blue (Neutral) wire to the terminal in the plug marked 'N' or coloured black.
3. Connect the brown (Live) wire to the terminal marked 'L' or coloured red.

With alternative plugs a 5A fuse must be fitted either in the plug or adaptor or in the main fuse box. In the event of replacing a fuse in the plug supplied, a 13A ASTA approved fuse to BS1362 must be fitted.

If the plug is the moulded on type the fuse cover must be refitted when changing the fuse. In the event of losing the fuse cover the plug must **not** be used until a replacement fuse cover has been obtained and fitted. A new fuse cover can be obtained from your nearest Hotpoint Spares Centre or local Electricity Company. The colour of the correct replacement fuse cover is that of the coloured marks or insert in the base of the plug.

## Mains Lead Replacement

If the mains lead on this appliance needs replacing at any time, it must be replaced by a special lead which is obtainable from your nearest Hotpoint Service Office (see back page). A charge will be made for the replacement of the mains lead if you have damaged the lead or require a longer lead.

**WARNING: HOW TO AVOID ACCIDENTS TO CHILDREN. WHEN DISCARDING AN OLD FRIDGE OR FREEZER BE CERTAIN TO MAKE THE LOCK UNUSABLE. IF POSSIBLE REMOVE THE DOOR AND DISCARD SEPARATELY. DO NOT ATTEMPT TO STAND OR SIT ON TOP OF YOUR APPLIANCE. IT IS NOT DESIGNED FOR SUCH USE AND YOU COULD INJURE YOURSELF OR DAMAGE THE APPLIANCE BY SUCH ABUSE.**

**CHILDREN SHOULD NOT BE ALLOWED TO PLAY WITH THE APPLIANCE OR TAMPER WITH THE CONTROLS.**

# Contents

**THIS BOOK COVERS MODELS 8732, 8742 AND 8764**

	<b>Page</b>
<b>Get to know your Freezer</b>	
<b>Installing your Freezer</b>	<b>4</b>
Where to put your freezer	
Decor panel/trinkets	5-6
Installing next to a Fridge or Larder Fridge	
<b>Getting your Freezer ready for use</b>	
Starting and Running In	<b>7</b>
<b>The Controls</b>	
The Lights – what they mean	
Fast Freeze Switch	
Economy Switch	<b>8</b>
<b>Storing Food</b>	
Storing already frozen food	
Freezing fresh foods – maximum freezing loads and how to freeze them	
Do's and Don'ts	<b>9-10</b>
<b>Caring for your Freezer</b>	
Defrosting	
Cleaning	
Table Top	
Going Away	<b>11-13</b>
<b>If your Freezer won't work</b>	
Repositioning the door hinge	<b>13</b>
<b>Hotpoint Service Cover</b>	<b>14-15</b>
<b>Hotpoint Service Offices and Spares Centres</b>	<b>16</b>
<b>Retention of the Instruction Book</b>	<b>Back Page</b>

This Instruction Book must be kept handy for reference as it contains important details on the safe and proper use of the appliance.

If you sell or pass the appliance to someone else, or move house and leave it behind, make sure this Book is also provided so the new owner can become familiar with the appliance and safety warnings.

If the Book is lost or damaged a copy may be obtained from Hotpoint Ltd, Celta Road, Peterborough, PE2 9JB.

# Get to know your Freezer

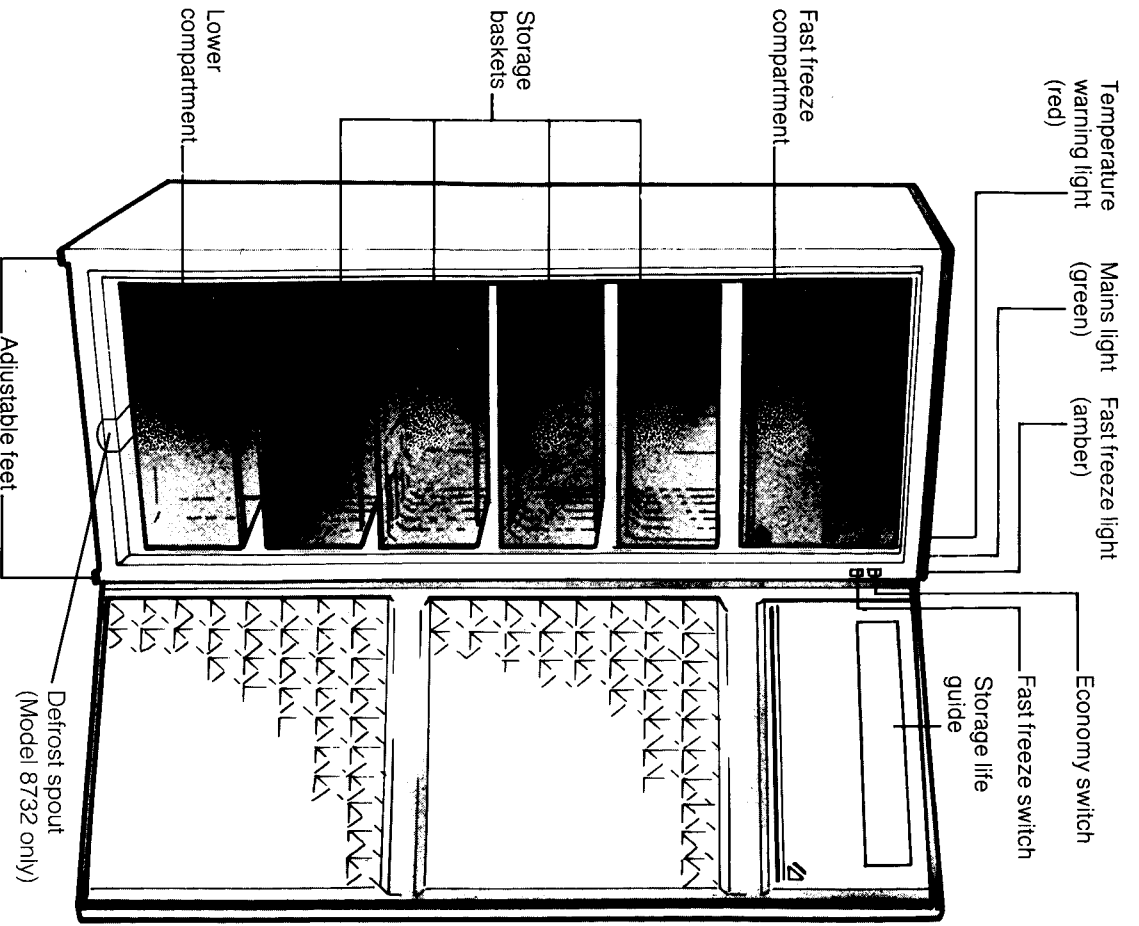

## Model 8764

(Models 8732 and 8742 are smaller and have an air grille at the back of the work top.)

# Hotpoint Service Cover

## Satisfaction Guaranteed or Your Money Back

Hotpoint gives you a unique 'Satisfaction Guaranteed' promise – valid for ninety days after you have purchased your Hotpoint product. If there is a problem with your Hotpoint appliance just call your Hotpoint Service Office. If necessary we will arrange for an engineer to call. If the problem is not resolved by us under this Guarantee, Hotpoint will replace your appliance or, if you prefer, give you your money back. This Guarantee is additional and subject to the terms of Hotpoint's Five Year Parts Guarantee.

## Hotpoint's Free Five Year Guarantee

From the moment your appliance is delivered, Hotpoint guarantees it for **FIVE YEARS**.

- In the Five Years all replacement parts are provided they are fitted by our own Service Engineer. During the first year our Engineer's time and labour is also free. Our Guarantee also covers loss of food in our Refrigeration and Freezer products up to £250 during the first Year.
- After the first year we will charge for our Engineer's time and labour. We do, however, operate a range of Service Plans (see opposite) which for an annual payment enables you to cover any repair costs which may be necessary.
- All our service repairs are guaranteed for twelve months in respect of our labour and any parts fitted.
- The appliance must be used in the United Kingdom and must not be tampered with or taken apart by anyone other than our own Service Engineer.
- You may, however, buy parts which can be safely fitted without specialist knowledge or equipment. The correct fitting of such parts, provided they are genuine Hotpoint spares, will not affect your Guarantee. Parts are available from our main Hotpoint Spares Centres (see back page).
- Our Guarantee does not cover the cost of any repair which is needed because of power cuts, accidents or misuse. Nor does it cover the cost of any visit to advise you on the use of the appliance. Please read the instruction book thoroughly.
- If at any time during the Guarantee period we are unable to repair your appliance, we will refund any repair costs paid to us in the previous twelve months. We will also offer you a new appliance at a reduced charge instead of a repair.
- Our Guarantee is in addition to and does not affect your legal rights.
- Should you need independent advice on your consumer rights, help is available from your Consumer Advice Centre, Law Centre, Trading Standards Department and Citizens Advice Bureau.

- All Hotpoint servicing is done by our own Service Organisation located throughout the United Kingdom and Southern Ireland. It will be happy to deal with any problems.

## Hotpoint's Service Care

Whether you have just one or a number of Hotpoint appliances in your kitchen Hotpoint has a range of Service Schemes to give you complete peace of mind.

## Service Cover

A single payment covers you for all repairs during the period of cover, which can be from 1 to 4 years. There is also an option of Service Cover with Maintenance at an additional cost. This includes an annual Electrical and Safety check and replacement of any parts as necessary. For 1 year contracts this takes place towards the end of the contract period.

## Kitchen Cover

An annual payment covers you for all repairs for all your Hotpoint appliances which are less than ten years old. It also covers the cost of loss of food up to £250 in our refrigeration and freezer products. There is also an option of Kitchen Cover with Maintenance at an additional cost. Any additional Hotpoint appliances purchased after you have joined Hotpoint Kitchen Cover will automatically be included during the annual period of cover without further charge.

## Appliance Registration

To ensure that you have the opportunity to benefit from any of the above Service Schemes you should complete and return immediately the Appliance Registration Form supplied with your appliance. Full details and costs of our Service Schemes together with an application form will be sent to you at the end of the first year of the guarantee.

## Annual Safety/Maintenance Checks

Hotpoint strongly recommends that all its appliances are regularly checked for electrical and mechanical safety whether or not they are covered by a Service Plan.

## Proof of Purchase

For future reference please attach your purchase receipt to this booklet and keep it in a safe place.

## Spares and Accessories

Spares and accessories can be ordered from your local Hotpoint Spares Centre (listed on the back page), using the order form enclosed.

**NOTE:** Our Engineer will use every effort to avoid damage to floor coverings and adjacent units when carrying out repairs/service work but in locations where the Engineer advises you that it will be impossible to move the appliance without risk of damage, he will only proceed with your approval that no liability is accepted.

# Installing your Freezer

## Where to put your freezer

Your freezer should be placed where it is easy to use, alongside or beneath a work surface is often a good position. Avoid putting it near anything which gives off heat, a cooker or radiator for example. In such a position your freezer will have to work harder and will cost more to run, and may also be damaged by the heat.

**Once you have decided on the most suitable place, make sure that there is adequate air circulation at the back of the freezer.**

**For Model 8742 or Model 8732 just push the freezer back until the grille is against the wall.**

**For Model 8764 fit the two wall spacers supplied to the top of the condenser as shown and push the freezer back until the spacers are against the wall. This ensures adequate air circulation at the back of the freezer.**

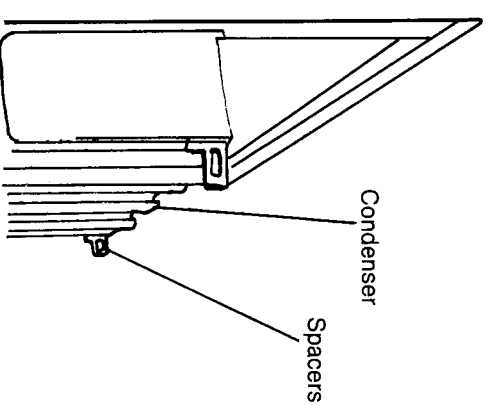

Model 8759 only

If Model 8742 or Model 8732 is placed underneath a work surface,

then adequate ventilation **must** be provided to maintain operating efficiency. Make sure there is a gap of 30mm (1 1/4in) between the top of the freezer and the underside of the work surface. If there is not enough clearance available then ventilation must be provided by fitting an air grille. To increase efficiency and reduce the running cost of your appliance we recommend the fitting of an air grille at the rear of the work surface. This grille, Part No. 8040 is available from your retailer or nearest Hotpoint Spares Centre using the Accessories Order form supplied with your freezer.

If Model 8764 is placed underneath any wall cupboards, make sure that there is a gap of at least 100mm (4in) between the top of the freezer and the underside of the cupboards. Finally, make sure your freezer is standing correctly by carefully adjusting the two front feet by turning them clockwise or anti-clockwise, until all four feet are in firm contact with the floor. Correct adjustment avoids excessive vibration and noise. On Model 8732, correct levelling ensures defrost-water drains from the spout (see page 13).



A Wheel Kit, Part No. 8031, for fitting to the back of Models 8732 and 8742, is available from your retailer or nearest Hotpoint Spares Centre using the Accessories Order Form supplied.

The Wheel Kit is not designed to be fitted on Model 8764.

**WARNING: YOU SHOULD NOT STACK YOUR FREEZER WITH ANY OTHER APPLIANCE.**

## Installing next to a Fridge or Larder Fridge

This can be done in one of two ways – either free standing or linked.

**Free standing:** Just slide in next to the Fridge, but leave a gap of 50mm (2in) between the two appliances to avoid a build up of condensation. Make sure both appliances stand correctly (see page 5).

**Linking:** If you have either Hotpoint Freezer you can join them with the appropriate Larder Fridge to make them look like one unit.

To join Model 8742 with Model 8132/8242 or Model 8732 with Model 8112/8232 requires linking kit Part No. 80110 (Brown) or Part No. 80111 (White).

To join Model 8764 with Model 8154 requires linking kit Part No. 8020 (Brown) or Part No. 8021 (White).

These are available from your retailer or nearest Hotpoint Spares Centre (see back page) using the Accessories Order Form supplied with your Freezer.

The kit comes complete with wheels so that the unit can be easily moved.

The widths of the linked appliances are as follows:

8232/8112 and 8732 – 998mm (39.3in)  
8132/8242 and 8742 – 1108mm (43.6in)  
8154 and 8764 – 1108mm (43.6in)

**Note: To ensure that the doors function properly you will need to change the left hand appliance so that its door hinges on the left hand side (see pages 7 and 8). Also make sure that the two appliances stand correctly and firmly (see page 5).**

## Fitting decor panels to match your kitchen units

For that fully co-ordinated kitchen look it is possible to fit a matching decor panel to your freezer. A special trim kit is available from Hotpoint that attaches to the edges of the appliance door and enables a decor panel, up to 4mm (1/8in) thick, to be fitted. Decor panels are available from most kitchen suppliers.

Model 8742 and Model 8732 require trim kit Part No. 8001 (Brown) or Part No. 8004 (White).

Model 8764 requires trim kit Part No. 8002 (Brown) or Part No. 8005 (White).

These are available from your retailer or nearest Hotpoint Spares Centre (see back page) using the Accessories Order Form supplied with your freezer.

15. Check the door opens and closes freely. Ensure door seal is seated evenly around the cabinet.
  16. Finally put back all the loose items/fitings.
  17. The freezer must be stood upright for at least 15 minutes before being switched on.
- NOTE:** If difficulties are encountered, contact your local Service Office.

## Repositioning the door hinge

Just follow the step by step instructions below:

**Tools required:** A 7mm/8mm A/F Spanner or a No. 2 Pozdriv.

1. Remove all loose items/fittings from inside the freezer.
2. Carefully lay the freezer on its back (you may need a second person to support the freezer). **Take care to avoid damage to the pipework by keeping it clear of the floor or by laying it on some protective material (eg. its original packaging).**
3. Unscrew and remove the two front feet.
4. Unscrew and remove the bottom hinge. Ensure any spacing washers fitted, and the fixing screws, are kept with the hinge.
5. Remove the door by gently pulling it downwards. Stand the door carefully to one side.
6. Unscrew and remove the top hinge, then replace the screws.
7. Remove the two hinge fixing screws on the top left hand side and use them to refit the top hinge.
8. Remove the plate from the front/bottom left hand side of the cabinet and refit on the right hand side where the bottom hinge was.
9. **Preparing the door for change over.**
  - a) Remove the top and bottom hinge bushes and the blanking plug, with a thin blunt instrument taking care not to mark the handle. Reposition on the opposite side.

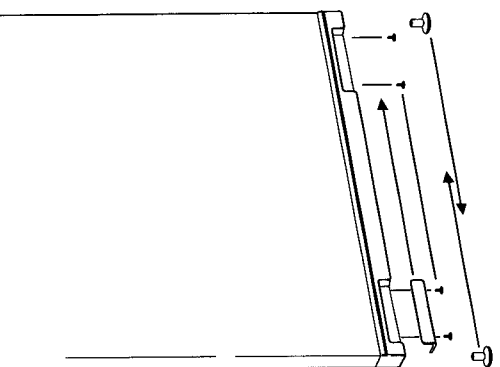

- b) Unscrew and remove the handle insert and replace the screws. Refit the insert with the screws from the left hand side.
10. Refit the door, sliding it upwards, locating the top hinge pin in the door hinge bush.
  11. Fit the bottom hinge (and spacing washers) into the bottom hinge bush, ensuring the door is evenly positioned about the cabinet sides.
  12. Using the two fixing screws secure the bottom hinge to the cabinet.
  13. Replace the adjustable front feet, setting them 25mm from the bottom of the cabinet to the bottom of the foot for appliances 850mm high or 36mm for taller appliances.
  14. Carefully stand your freezer upright (you may need assistance for this) in the required location. Adjust the front feet until all four feet are in firm contact with the floor and the appliance does not rock. **(See Installing Your Freezer.)**

## Getting your Freezer ready for use

Before using your freezer for the first time the interior, including the door, and all removable parts should be wiped out. Use a damp cloth wrung out in either a solution of one teaspoonful of bicarbonate of soda to one pint of water or Milton diluted according to the manufacturer's instructions.

**WARNING: NEVER USE ANY HOUSEHOLD CLEANER OR DETERGENT, ABRASIVE POWDERS OR WAX POLISH. THESE NOT ONLY DAMAGE THE SURFACES, THEY ALSO LEAVE A SMELL IN THE FREEZER.**

### Final check

Before you start using the freezer, check that

1. it is thoroughly dry inside,
2. air can circulate freely, at the rear,
3. the feet have been adjusted, i.e. all four are firmly on the ground.

### Starting

Insert the plug into the wall socket and switch on the electricity supply. The green (mains) and red (temperature warning) lights will come on together and your freezer will start working. You will hear a noise as the compressor starts up. If you are going to store already frozen food open the freezer door and check that the Fast Freeze switch is at 'O' (Off). The red light will go out when the freezer has reached the correct temperature. Then you can put in your already frozen food.

If you are going to freeze fresh food, you must press '★' (ON) on the Fast Freeze switch. The amber light will come on and you must **wait at least three hours** before putting in your fresh food to be frozen. Do not put more than 10.5kg (23lb) of fresh food to be frozen in Model 8732 12kg (26.5lb) in Model 8742 or 14kg (30.8lb) in Model 8764 (see pages 11 and 12).

### Running-in the compressor

The liquid and gases sealed within the refrigeration system may give rise to noise, whether the compressor is running or not. This is quite normal.

Your freezer is operated by a compressor which switches on and off in order to maintain the freezer's temperature. The compressor is a precision piece of machinery like a car engine, and requires a running-in period of up to 2 months. During this time the compressor has to work a little harder and this may result in more noise than usual.

**Note: Your freezer is designed only for domestic purposes: for the freezing of fresh food and storage of frozen food.**

# The Controls

## Controlling the Temperature

Your freezer is fitted with a factory set thermostat control which does not require any adjustment.

In the summer months, or in conditions giving high temperatures around the freezer, the compressor has to work harder and run for longer periods. This is quite normal.

Conversely, during cold weather the compressor will run for much shorter periods.

A fridge/freezer thermometer, Part No. 8058 is available to ensure that you maintain your appliance at the correct temperature. This can be ordered from your local Hotpoint Spares Centre (see back page) using the order form enclosed.

## Green Mains Light

Comes on and stays on as long as the electricity supply is not interrupted.

## Red Temperature Warning Light

Comes on when the temperature inside the freezer rises above the correct storage temperature. If it comes on for a short period when you open the door to load or unload food, storage times will not be affected. However, if the red light stays on this indicates that something is wrong. First check that the door has not been accidentally left open, if this is not the case, call your nearest Hotpoint Service Office (see back page). If the delay is likely to be longer than 12½ hours for Model 8732, 15½ hours for Model 8742 or 15 hours for Model 8764 then the food should either be defrosted and eaten immediately, defrosted,

cooked and then refrozen or transferred to another freezer.

## Fast Freeze Switch and Amber Fast Freeze Light

Press '\*' (**ON** position) when freezing fresh food and the amber light will come on (see Freezing Fresh Foods, page 11).

## Economy Switch

Your freezer incorporates a low energy heater to reduce condensation on the cabinet sides. Press 'E' (Economy position) for normal conditions.

If the room is cold or humid or if freezing fresh food, water droplets may form on the outside of the freezer. When this happens press 'H' (Humid position). The low energy heater will operate continuously and the water droplets will disappear. When conditions return to normal, reset the switch to 'E' and the heater will operate intermittently.

**Note: The outside front edges of the freezer may feel warm. This is normal.**

## Going away

If you expect to be away for any length of time and don't want to use your freezer, switch off at the socket outlet and pull out the plug. Remove all food and follow the defrosting instructions (see page 13). After defrosting dry out the interior. **Always** leave the door ajar to prevent the accumulation of odours.

## If your Freezer won't work . . . don't panic

Just run through these quick checks before calling your nearest Hotpoint Service Office.

1. Check that the plug is firmly in the socket outlet and that the power supply is on.
2. Check the power supply to the socket outlet by plugging in another appliance.
3. If the other appliance works, check the fuse in the freezer's plug.
4. If you have changed the plug, check the wiring (see page 2).
5. If there is excessive noise or vibration, check that all four feet are firmly in contact with the ground (see page 5).
6. If water droplets appear on the outside of the cabinet, check that you have the Economy switch set on 'H' (see page 10).
7. You may find the freezer difficult to open just after you have used it. This is due to a pressure difference which will soon equalise. Wait a few minutes then open the door.

If, after following all these instructions, you are still having problems, contact your nearest

Hotpoint Service Office (or local importer if outside the United Kingdom). The telephone number is shown on the back page.

When you contact us we need to know:

1. Your name, address and post code.
2. Your telephone number.
3. Clear and concise details of the fault.
4. The model number (8732, 8742 or 8764), serial number (found on the label on the underside of the front top of the appliance), and colour.
5. When it was purchased.
6. If you have subscribed to the Hotpoint Service Cover Plan.

Make sure you have all these details before you call.

## Spare Parts

Please remember your new appliance is a complex piece of equipment.

'DIY' repairs or unqualified and untrained service people may put you in danger, could damage the appliance and might mean you lose cover under Hotpoint's Parts Guarantee.

If you do experience a problem with the appliance don't take risks: call in Hotpoint's own Service Engineer. The address and telephone number of your nearest Hotpoint Service Office in in your local telephone directory.

Our spare parts are designed exclusively to fit only Hotpoint appliances. Do not use them for any other purpose as you may create a safety hazard.



## Cleaning your Freezer

It is a good idea to clean the inside of your freezer after defrosting. Always **switch off at the socket outlet and pull out the mains plug first**. Wipe out the inside of the freezer using a clean cloth wrung out in either a solution of one teaspoonful of bicarbonate of soda to one pint of water or Milton diluted according to the manufacturer's instructions. The complete interior including the door, and removable parts, should be washed.

## Removing Fast Freeze and Lower Compartment Doors

Note: For cleaning and better access when defrosting, the Lower Compartment and Fast Freeze Compartment doors can be removed without using any tools.

This is done by opening the compartment door 45 degrees and lifting the **left hand** corner so that the pin comes up and out of the special hinge. The door can then be

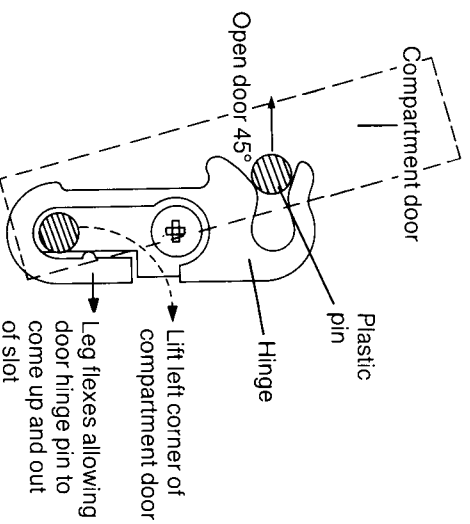

removed from the right hand hinge by pulling the door to the left.

To replace each door after cleaning: Ensure the upper door pins are positioned in front of the hinges. Fit the right hand, bottom door pin into the bottom slot in the right hand hinge. Then pull the left hand bottom pin in through the back slot in the left hand hinge. Press down on the left top corner of the door so that the pin goes fully home in the hinge.

**Never** use any household cleaner or detergent, abrasive powders or wax polish. These not only damage the surfaces, but also leave a smell in the freezer. **Before** you refill the freezer ensure it is thoroughly dry.

Clean the outside of your freezer, **but not the door seal and handle**, with a damp cloth, using a small amount of detergent, followed by a wipe down with a clean cloth. **Do not** use an abrasive powder. **The rubber door seal and handle must be cleaned with soap and water only as detergent will damage it.**

Finally, the compressor and condenser at the back of the freezer can be carefully cleaned. Use a brush or vacuum cleaner to remove any dust. **Always** check that the freezer is disconnected from the mains electricity supply **before** doing this. Remember to re-connect the mains plug and switch on after cleaning your freezer.

## Table top

This is designed to serve as an extra work surface, but be careful with it. **Do not** drop/place heavy objects on it or sit on it.

## Storing Food

### Storing food in your freezer

Your freezer carries the **\*\*\*** symbol which indicates that it is suitable for the long-term storage of commercially frozen foods and also can be used to freeze and store fresh food.

Model 8732 will store up to 28kg (61.4lb) of frozen food, Model 8742 will store up to 32kg (70lb) and Model 8764 up to 55.5kg (122.4lb).

These figures are based on an average density of 0.32kg of mixed food per litre of net storage volume (20lb per cubic foot). In the case of meat they will take appreciably more.

Generally speaking long-term storage means up to 3 months, but this will vary with the nature of the packaged food, so always follow the manufacturer's recommended storage time given on the packet. For storing home frozen fresh food refer to the pictorial guide on the door liner.

If there is a power failure **do not open the door**. Frozen food should not be affected if the failure lasts for less than 12½ hours for Model 8732, 15½ hours for Model 8742 or 15 hours for Model 8764. If the failure is longer, then the food should be checked and either eaten immediately or cooked and then refrozen.

### Freezing Fresh Foods

#### Maximum Freezing Loads

You can freeze up to 10.5kg (23lb) of fresh or cooked food in Model 8732, 12kg (26.5lb) in Model 8742 and up to 14kg (30.8lb) in Model 8764 in any 24 hours. Slightly larger quantities can be frozen if the Fast Freeze

switch is set to '★' (ON) 24 hours beforehand.

**Freezing up to 10kg (22lb) in Models 8742 and 8764 and up to 10.5kg (23lb) in Model 8732**

1. Transfer any frozen food from the Fast Freeze compartment to the storage baskets or lower compartment.

2. Press '★' (ON position) on the Fast Freeze switch. The amber Fast Freeze light will come on. If the freezer has not been in use it will be necessary to set the Fast Freeze switch to '★' at least 3 hours before putting in the fresh food.

3. Press 'H' on the Economy switch to avoid condensation on the outside of the freezer compartment.

4. For Models 8742 and 8764 put the fresh food into the Fast Freeze compartment with as much food as possible in contact with the compartment floor. For Model 8732 put 7.5kg (16.5lb) of fresh food in to the Fast Freeze compartment and the remainder in the empty lower compartment with as much food as possible in contact with the compartment floors.

5. Leave the Fast Freeze switch on for 24 hours if the maximum quantity (10kg) is being frozen or proportionally less time for smaller quantities.

6. Reset the Fast Freeze switch to 'E', 'O' and the Economy switch to 'E' when freezing is complete.

**Freezing up to 12kg (26.5lb) in Model 8742 and up to 14kg (30.8lb) in Model 8764**

1. Transfer any frozen food from the

Fast Freeze and lower compartments to the storage baskets.

2. Press '\*' (**ON** position) on the Fast Freeze switch. The amber Fast Freeze light will come on. If the freezer has not been in use it will be necessary to set the Fast Freeze switch to '\*' at least 3 hours before putting in the fresh food. Also if you set the Fast Freeze switch to '\*' 24 hours beforehand you will be able to freeze slightly larger quantities
3. Press 'H' on the Economy switch to avoid condensation on the outside of the freezer.
4. Put 8kg (17.5lb) for Model 8742 and 10kg (22lb) for Model 8764 of fresh food into the Fast Freeze compartment and the remainder in the lower compartment with as much food as possible in contact with the compartment floors.
5. Leave the switches on for 24 hours then reset the Fast Freeze switch to 'O' and the Economy switch to 'E'.

### Do's and Don'ts

- Do:-** Always choose high quality fresh food and be sure it is thoroughly clean before you freeze it.
- Do:-** Prepare fresh food for freezing in small portions to ensure rapid freezing.
- Do:-** Remember lean foods last longer than fat foods and salt will reduce storage life.
- Do:-** Wrap all foods in aluminium foil or freezer quality polythene bags and make sure any air is excluded. Keep the door shut when freezing fresh foods.

**Do:-** Separate food in different baskets for easy identification.

**Do:-** Wrap frozen food when you buy it and put it into the freezer as soon as possible.

**Do:-** Store commercially frozen food in accordance with the instructions given on the packets that you buy.

**Do:-** Defrost the freezer before the ice becomes thick (see page 13).

**Do:-** Ice cream should be removed from the freezer 15-30 minutes before serving.

**Don't:-** Exceed the maximum freezing loads when freezing fresh food (see pages 11 and 12).

**Don't:-** Put hot food into the freezer. Let it cool down first.

**Don't:-** Leave the door open for long periods as this will cause excessive ice formation and make the freezer more costly to run.

**Don't:-** Put liquid-filled bottles or sealed cans containing carbonated liquids (fizzy drinks, etc) into the freezer as they may burst.

**Don't:-** Try to keep frozen food which has thawed; it should be eaten within 24 hours or cooked and refrozen.

**Don't:-** Give children lollipops and water ices direct from the freezer. The low temperature may cause 'freezer burns' on their lips.

**Don't:-** Store poisonous or dangerous substances in the freezer. Your freezer has been designed for the storage of edible foodstuffs only.

## Caring for your Freezer

### Defrosting

Frost forms on the cold surfaces from the moisture in the air and improperly wrapped food. The frost will build up first on the roof of the fast freeze compartment, towards the front, this is normal.

From time to time remove the frost from this, and other frosted surfaces, using the plastic scraper provided.

**Never** use sharp metal tools to remove the frost – they could damage your freezer beyond repair. Periodically you will need to fully defrost your freezer, how often will be dependent on usage. Try to defrost when there is little or no food in the freezer.

Defrosting must be carried out as quickly as possible since a rise in the temperature of your frozen food may reduce the recommended storage time. Just follow these steps:

1. **Switch off and pull out the mains plug.**
2. Remove any frozen food. Wrap it in several layers of newspaper or a blanket and, using the storage baskets, put it in a cool place.
3. Place bowls of hot water (DO NOT use any other source of heat) in the Fast Freeze compartment and lower compartment and lower compartment. On Model 8732, fit the defrost spout to the base of the freezer by turning the spout over and then push into the slot provided. See diagram above. Place a container beneath the spout to collect the defrost water.
4. As soon as the frost begins to melt use the plastic scraper to chip it off.
5. Sponge out any defrost water which collects in the bottom of the freezer.
6. After defrosting remove the bowls and dry the interior thoroughly.
7. Replace the mains plug and switch on. Press '\*' (**ON**) on the Fast Freeze switch. Unwrap the frozen food and replace. On Model 8732 don't forget to remove spout from the slot. Close the door.
8. After three hours press 'O' (**OFF**) on the Fast Freeze switch. The amber light will go out.
9. Job done!

**Fitting the defrost spout (8732 only)** Lift at front to remove

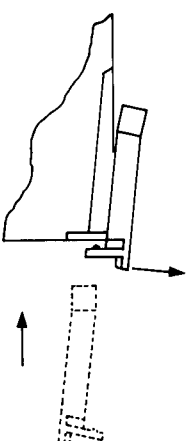

**Turn over spout and push in slot for defrosting. Place container under spout to collect water.**

**To ensure that the defrost water is drained effectively Model 8732 must be level. See page 5 for the correct adjustment of the levelling feet.**

### SIDE VIEW