

Centrifugal Fan Air-Cooled Condensers

Table 1 – Charging Data

UNIT 09FA	No.	COIL SPLIT					
		% Cap. Each	Min Chg Each (lb)	Refrig Vol Each (cu ft)	Storage Capacity Each (lb)*		
					R-12	R-22	R-500
006	1	100	5.0	34	21.8	19.7	18.6
008			7.5	49	31.4	28.4	26.8
012			10.5	66	42.2	38.3	36.0
016			15.75	97	62.1	57.3	53.0
024	2	50	10.75	65	41.3	37.4	35.2
		50	15.75	97	62.1	56.2	53.0
028†	3	8	2.5	16	9.9	9.0	8.5
		42	13.25	81	52.1	47.3	44.5
034†	3	50	14.75	90	57.3	51.9	48.9
		8	2.5	14	9.2	8.3	7.8
		42	12.5	75	48.1	43.6	41.0
044‡	2	50	22.5	134	85.8	77.7	61.6
044‡	3	33.3	15.0	89	57.2	51.8	48.8
044‡	3	37.5	17.0	101	64.3	58.3	54.9
		25	11.25	67	42.9	38.9	36.6
		37.5	17.0	101	64.3	58.3	54.9
		33.3	15.0	89	57.2	51.8	48.8
044‡	6	4.2	2.0	11	7.15	6.48	6.10
		12.5	5.75	34	21.4	19.4	18.3
		12.5	5.75	34	21.4	19.4	18.3
		4.2	2.0	11	7.15	6.48	6.10
		33.3	15.0	89	57.2	51.8	48.8

*80% liquid, 20% vapor @ 90 F

†Manifolds for piping 50/50 and 42/58 coil splits are field supplied

‡Manifolds for piping 33.3/33.3/33.3; 37.5/25/37.5; and 50/50 coil splits are available as accessories

NOTE: All manifolds must be field installed

START-UP

System Evacuation, Dehydration, and Charging – Refer to Table 1 and Carrier Standard Service Techniques Manual, Chapter 1, sections 1-7 and 1-8.

It is recommended that a liquid line moisture-indicating sight glass and filter-drier be used in the system.

SERVICE

Fan Belt Removal

1. Remove belt guard.
2. Loosen four support angle bolts. Refer to Fig. 1.
3. Release belt tension by unthreading jack screw. Remove belt(s).

4. Replace in reverse order. Tighten all bolts securely. Check belt tension. Belt(s) should be just tight enough to prevent start-up squeal. Satisfactory deflection is approximately 1/2-inch. Use matched sets of belts on all multiple belt drives.

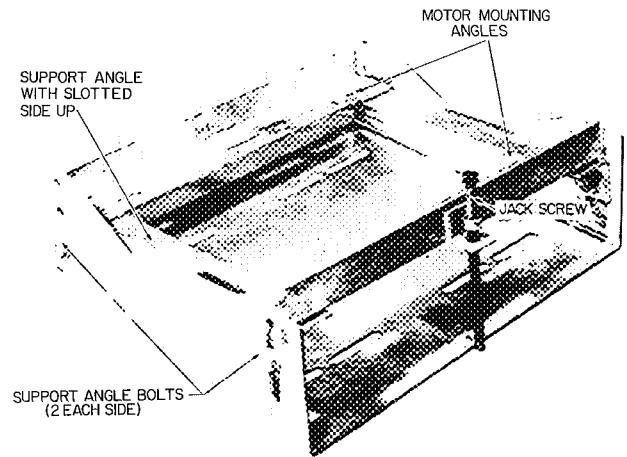
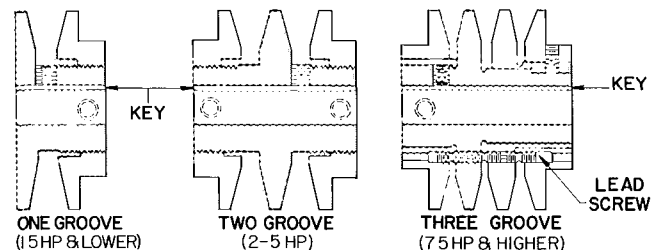

Fig. 1 – Motor Mounting Bracket

Fan Motor Sheave Removal

1. Remove fan belt.
2. Loosen hub allen setscrew. Refer to Fig. 2.



FIXED FLANGE WITH HUB ALLEN SETSCREWS
MOVABLE FLANGE WITH ALLEN SETSCREWS

Fig. 2 – Fan Motor Sheaves

3. Tap sheave off keyed fan motor shaft.
4. Replace sheave in reverse order. Tighten allen setscrew securely. Lightly grease motor shaft before replacing sheave. Remove all dirt and burrs from motor shaft end and key. Check alignment of fan motor sheave with fan shaft sheave. Correct by loosening motor hold-down bolts and shifting motor as required. Tighten motor hold-down bolts securely. Refer to Fig. 3.
5. Replace fan belt.

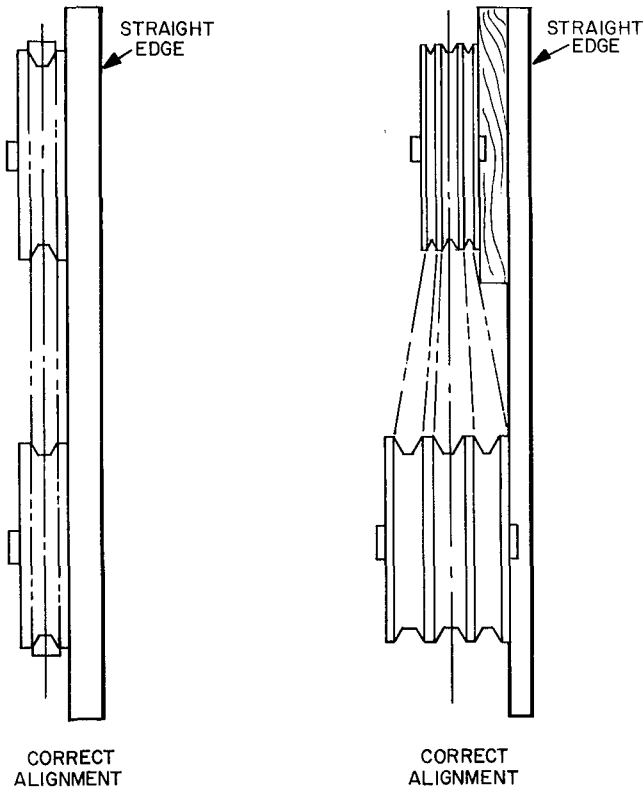

Fig. 3 – Sheave Alignment

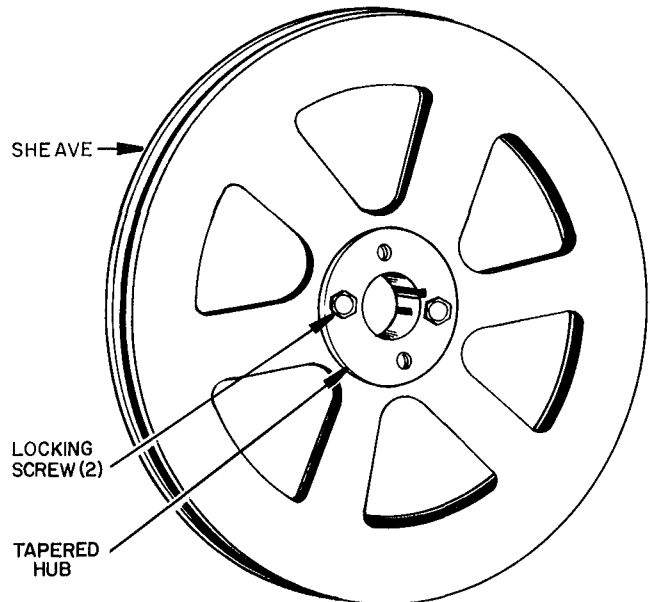

Fig. 4 – Fan Shaft Sheave

Fan Motor Sheave Adjustment

ONE- AND TWO-GROOVE SHEAVES

1. Remove fan belt.
2. Loosen movable flange allen setscrew(s). Refer to Fig. 2.
3. Rotate movable flange(s) around threaded hub to desired pitch. Tighten all setscrews securely.

CAUTION: Tighten movable flange allen setscrews on hub flat(s) only - not threads.

4. Replace fan belt.

THREE-GROOVE SHEAVES

1. Remove fan belt.
2. Loosen movable flange allen setscrews. Refer to Fig. 2.

CAUTION: Loosen movable flange allen setscrews only one turn. One of the movable flange allen setscrews also serves as a stop, preventing pulley disassembly.

3. Rotate lead screw, sliding flanges to desired pitch. Tighten all setscrews securely. Refer to Fig. 2.

CAUTION: Do not unthread lead screw. Reassembly requires a special jig.

4. Replace fan belt.

Fan Shaft Sheave Removal

1. Remove fan belt.
2. Loosen and remove locking screws. Refer to Fig. 4.

3. Engage locking screws in hub threaded holes.
4. Tighten screws until sheave bore is free from hub. Remove sheave. Hub may be removed by tapping off keyed fan shaft.
5. Replace sheave in reverse order. Tighten locking screws securely. Lightly grease fan shaft end before replacing sheave. Remove all dirt and burrs from fan shaft end. Check alignment of fan motor sheave with fan shaft sheave. Correct by loosening motor hold-down bolts and shifting motor as required. Tighten motor hold-down bolts securely. Refer to Fig. 3.
6. Replace fan belt.

Fan Shaft Bearing Removal (fixed and floating)

1. Remove fan shaft sheave (for fixed bearing removal only). Fixed bearing is located on shaft end nearest fan shaft sheave.
2. Loosen and remove dust cover screws. Remove dust cover (for fixed and floating bearing removal). Refer to Fig. 5.
3. Loosen locking collar allen setscrews. Tap and turn locking collar in opposite direction of fan shaft rotation. Refer to arrow on bearing plate, nearest motor, for proper rotation.
4. Remove locking collar and bearing.
5. Replace bearing in reverse order. Center floating bearing within its clearance to prevent squeal and damage. Thoroughly tighten locking collar against bearing inner race before tightening setscrew securely. Follow Fan Shaft Bearing Lubrication instructions.
6. Replace fan shaft sheave (for fixed bearing removal only). Fixed bearing is located on shaft end nearest fan shaft sheave.

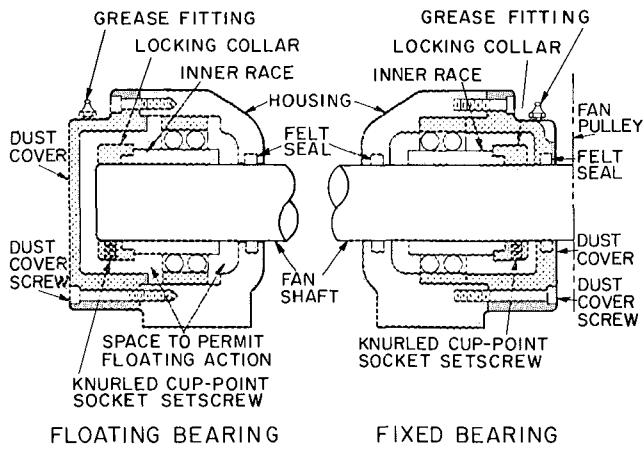

Fig. 5 – Fan Shaft Bearings

Fan Access Panel Removal

1. Loosen two bolts in lower corners of panel. Pull bolts out as far as cotter pins will allow. Refer to Fig. 6.
2. Using bolts as handles, lift panel upward so stiffening angle buttons at panel bottom will be free from coil casing angle recess.
3. Pull panel forward and drop out of clips on top.
4. Replace in reverse order.

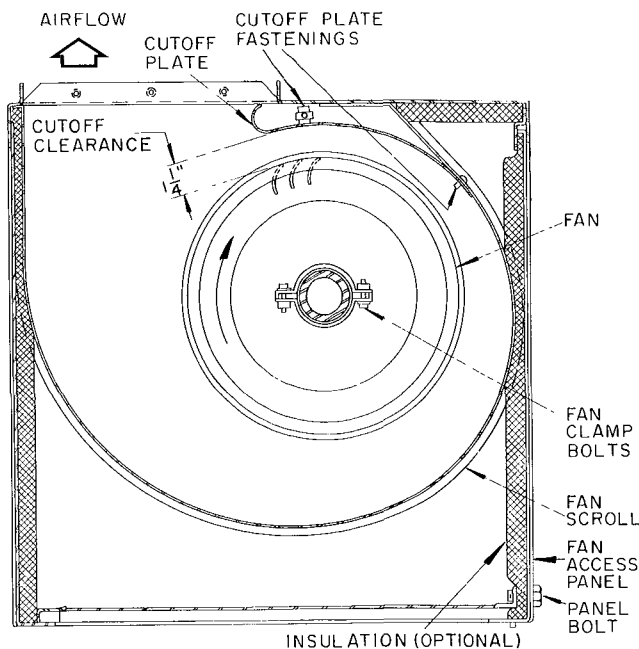

Fig. 6 – Fan Cross Section

Fan Rotation (90°)

1. Remove fan access panel.
2. Unbolt fan and coil sections. Rotate fan section - rebolt.
3. Relocate access panel on open side of fan section.
4. Replace fan access panel.

Fan Shaft Removal

1. Remove fixed and floating fan shaft bearings.
2. Remove fan access panel.
3. Loosen fan wheel clamp bolts. Remove four bearing plate bolts at one end of unit only. Refer to Fig. 7.

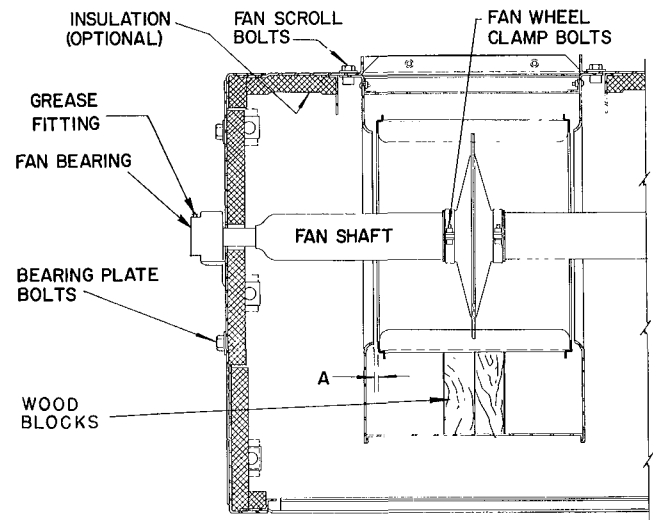

Fig. 7 – Fan Longitudinal Section

4. Remove bearing plate and housing (bolted to plate). Remove fan shaft. Block up fans in scrolls to ease drop.
5. Replace shaft in reverse order. Check fan wheel concentric alignment with fan scroll inlet opening. Correct by loosening three or four bearing plate bolts, end of unit nearest fan scroll, and rap bearing plate edge as required. Tighten bolts securely.

Dimension A must be equal on both sides of fan wheel. Correct by loosening fan wheel clamp bolts and sliding fan wheel as required. Tighten bolts securely. Refer to Fig. 7 - dimension A.

6. Replace fan access panel.
7. Replace fan shaft bearings.

Fan Wheel Removal

1. Remove fan shaft
2. Loosen and remove fan scroll mounting bolts. Refer to Fig. 7. Block up fan scrolls to prevent dropping.
3. Unscrew cutoff plate fastenings. Remove cutoff plate from fan scroll. Refer to Fig. 6.
4. Remove fan wheels from fan scrolls thru discharge opening
5. Replace fan wheels in reverse order. Adjust cutoff plate for 1-1/4-inch clearance. Tighten securely. Refer to Fig. 6. Fan blades must be as shown.
6. Replace fan shaft. Check fan wheel and shaft balance by rotating wheel slowly by hand. If it rocks back and forth it is out of balance. Correct by loosening fan wheel clamp bolts and rotate fan wheel slightly until best balance is found. Tighten bolts securely.

Lubrication

FAN MOTOR — Follow manufacturer's recommendations.

FAN BEARINGS — Fan bearings are prelubricated with high-quality grease and require no further lubrication the first year of operation. Relubricate each calendar year with Carrier PP80-10 multipurpose grease or equivalent. Add grease until air bubbles start escaping from under seal. Do not overgrease.

Cleanliness — Periodically clean the fan, bearing, and belts. Do not allow grease or oil into any insulation. This creates a fire hazard. Periodically clean condenser coil with a brush

and compressed air. In highly contaminated areas the use of filters should be considered.

Inspection**PERIODICALLY CHECK**

1. Secureness of: Sheaves to fan and motor shafts; fan shaft bearings, motor mounting brackets to unit; motor to bracket.
2. Pulley alignment and belt tension.
3. Fan wheels for: Freedom of rotation within scrolls; concentric alignment with fan scroll inlet opening; balance with fan shaft; secureness to fan shaft.

Manufacturer reserves the right to change any product specifications without notice

CARRIER AIR CONDITIONING COMPANY • SYRACUSE, NEW YORK