

PHILIPS

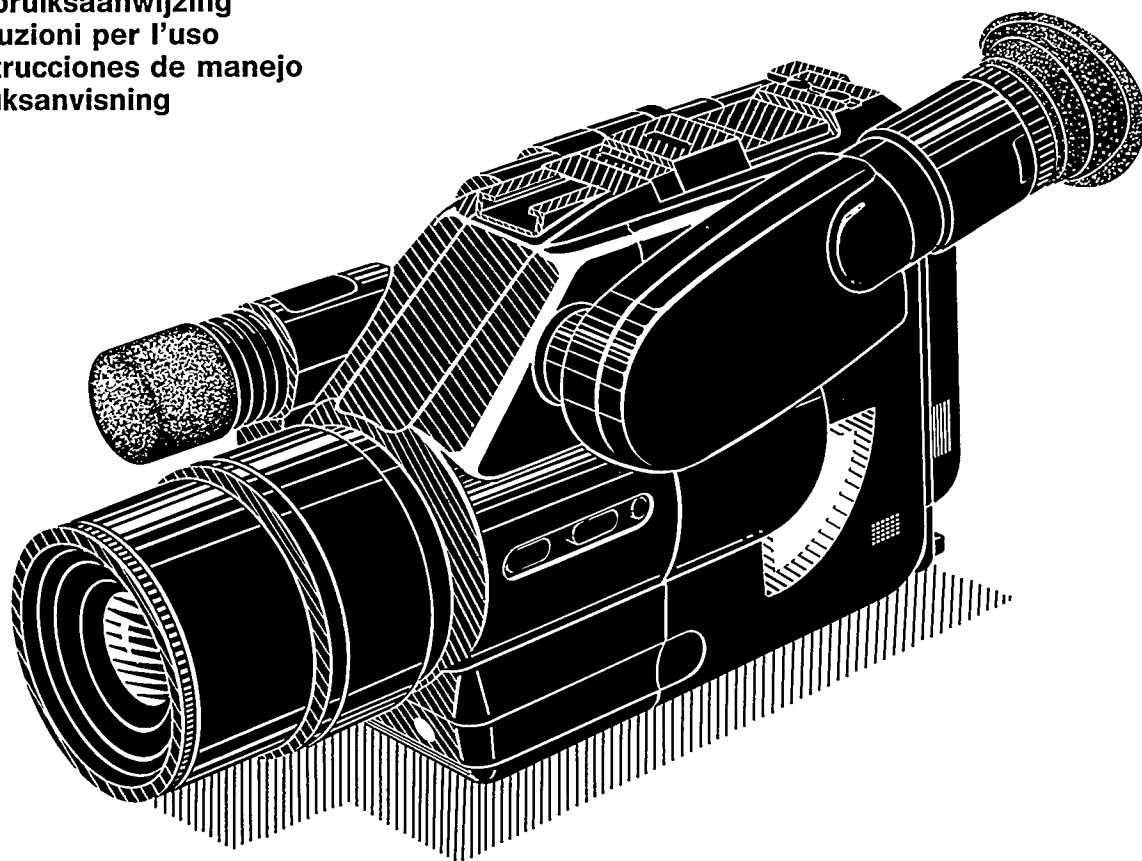

Operating instructions
Bedienungsanleitung
Mode d'emploi
Gebruiksaanwijzing
Istruzioni per l'uso
Instrucciones de manejo
Bruksanvisning

VHS
PAL



EXPLORER

C A M C O R D E R S

VKR6847



Controls and connectors

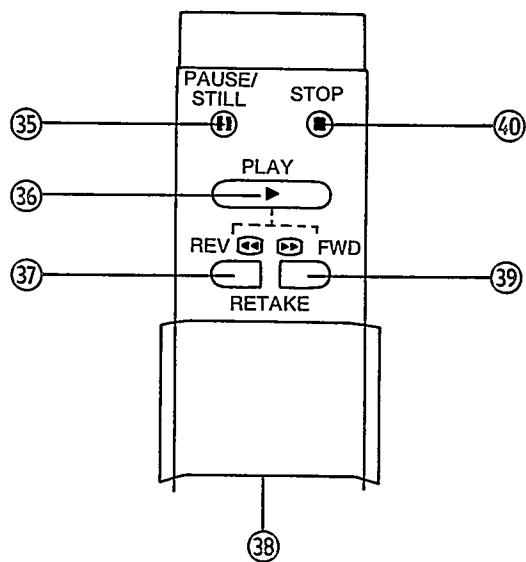
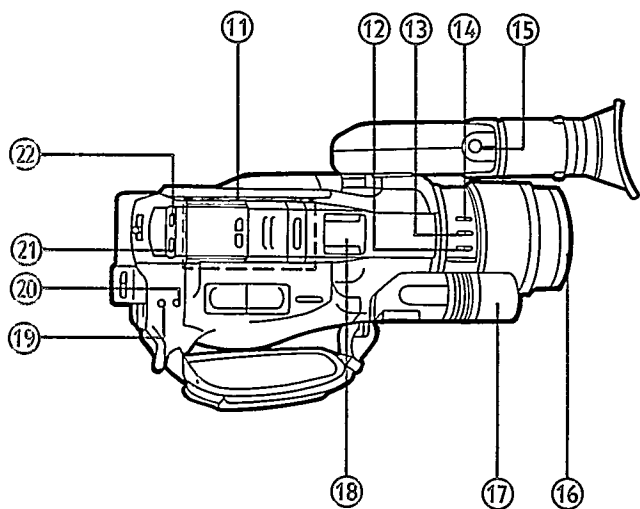
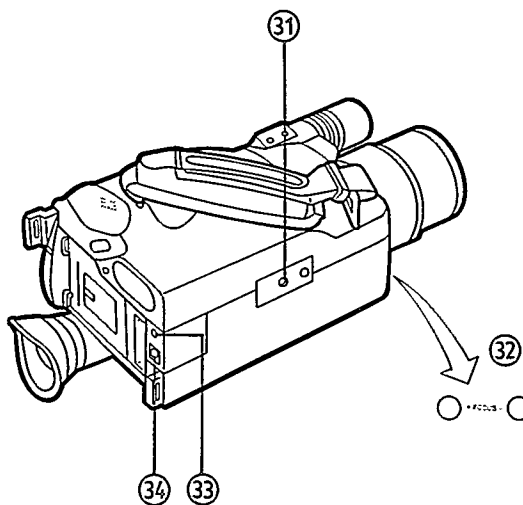
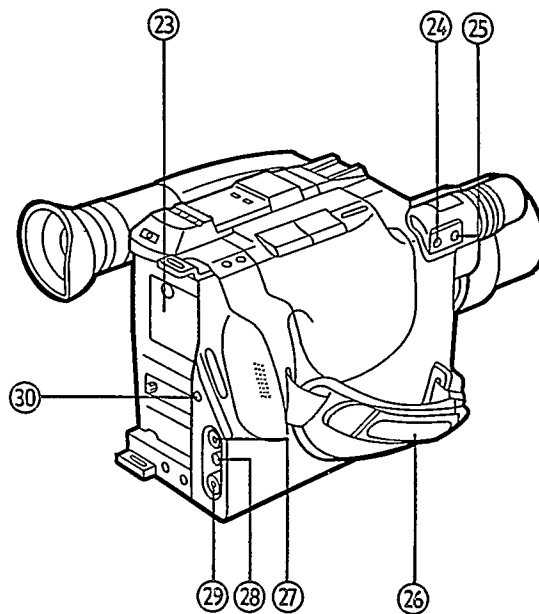
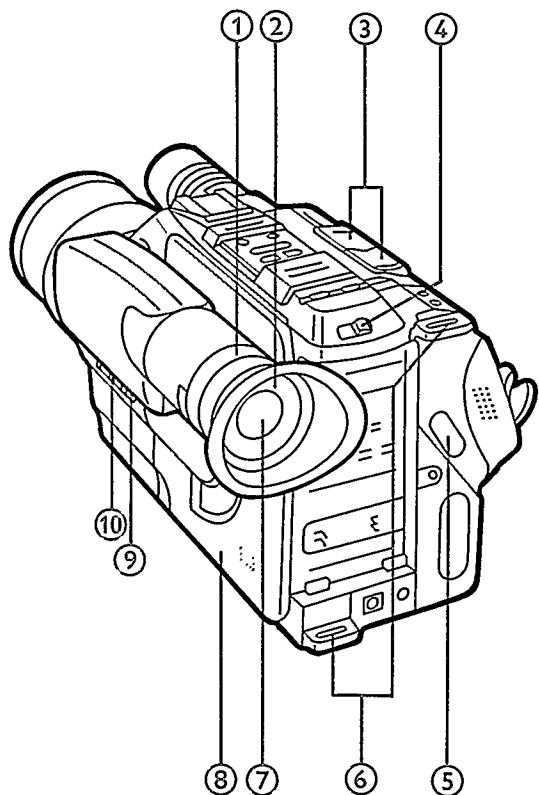

Contents

Important	3
Cautions	3
Camcorder accessories	5
Controls and components	6
Indications in the electronic viewfinder (EVF)	7
Power supply systems	8
Setting the date and time	10
Electronic viewfinder (EVF)	12
Video cassette	13
Camera recording	14
Advanced videography techniques	15
Focus	15
Macro close-up	15
White balance	16
High speed shutter	17
Zooming	17
Fade-in and Fade-out	18
Playback	19
Playback via TV set (connections)	20
Other functions	21
Assemble editing	22
Dubbing (copying)	22
Accessories, etc.	23
In case of difficulty	24
Specifications	25

Important

FOR YOUR SAFETY DO NOT REMOVE THE OUTER COVER

To prevent electric shock, do not remove the cover. No user serviceable parts inside. Refer servicing to qualified service personnel.

TO REDUCE THE RISK OF FIRE OR SHOCK HAZARD, DO NOT EXPOSE THIS EQUIPMENT TO RAIN OR MOISTURE.

■ WARNING ON BATTERY

Danger of explosion if battery is incorrectly replaced. Replace only with the same or equivalent type recommended by the equipment manufacturer. Discard used batteries according to manufacturer's instructions.

■ WARNING ON LITHIUM BATTERY

The battery used in this device may present a fire or chemical burn hazard if mistreated. Do not recharge, disassemble, heat above 100°C or incinerate. Replace battery with CR2032, use of another battery may present a risk of fire or explosion.

- Dispose of used battery promptly.
- Keep away from children.
- Do not disassemble and do not dispose of in fire.

■ CAMCORDER

- The rating plate is on the bottom side of the Camcorder.

■ AC adaptor

- The rating plate is on the bottom side of the unit.
- This model conforms to the EC directive (for radio interference) 87/308/EEC.

■ IMPORTANT (In the United Kingdom)

Mains Supply (240 V, 50 Hz only)

Do not make any connection to the larger terminal coded E or Green. The wires in the mains lead are coloured in accordance with following code:

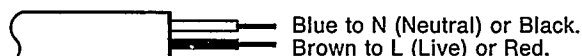

If these colours do not correspond with the terminal identifications of your plug, connect as follows: Blue wire to terminal coded N (Neutral) or coloured Black. Brown wire to terminal coded L (Live) or coloured Red. If in doubt — consult a competent electrician.

Note:

We recommend that you should disconnect the AC cord from the outlet.

Copyright laws

Your attention is drawn to the fact that recording of pre-recorded tapes or discs or other published or broadcast material may infringe copyright laws.

Cautions

Please read these cautions before operating the Camcorder, so that you will obtain the best results from your Camcorder.

Video head clogging:

The video heads are the means by which the Camcorder places picture signals on the tape during recording, and reads picture signals from the tape during playback. If these heads become dirty and clogged from long use, the signals can no longer be recorded correctly, and the playback picture will be distorted accordingly. This is the case, for example, during the playback of a tape, the sound of which is reproduced normally, but no picture is seen, or the picture is greatly distorted. When such symptoms occur, have the Camcorder checked by qualified service personnel.

If condensation forms inside the Camcorder:

Condensation (dew) forms, when warm air comes in contact with a cold object, for example on a window in a heated room in winter. Condensation may form in the Camcorder and damage the tape and the video heads, if:

- The Camcorder is in a room where the heater has just been turned on.
- The Camcorder is in a room with steam or high humidity.
- The Camcorder is brought from cold surroundings into a well-heated room.
- The Camcorder is suddenly brought from cool surroundings, such as an air-conditioned room or car, to a place which is hot and humid.
- When condensation has formed inside the Camcorder, the "DEW" indication in the electronic viewfinder (EVF) will flash and a few seconds later, the unit will turn itself off to protect the tape and the video heads.

After a while, turn the unit on again and make sure that the Dew mark is not displayed any more. Then, wait about 1 hour before operating the Camcorder again. Depending on the surrounding conditions, it may take several hours before the Camcorder can be used again.

- As condensation forms gradually, it may take about 10 – 15 minutes before the Camcorder turns itself off after a change of working environment.
- In an extremely cold place, condensation may freeze and turn into frost. In this case, it may take quite some time for the frost to melt, turn into dew and evaporate.
- When you bring the Camcorder from a very cold place e.g. the ski slopes, into a heated room, keep it in a tightly closed plastic bag or similar to prevent condensation from forming inside the Camcorder.

Keep the Camcorder away from oily smoke and steam.

Protect the Camcorder from humidity and dust.

Surrounding conditions:

Use the Camcorder under conditions where the temperatures are between 0°C and 40°C and where the humidity is between 20 % and 80 %. To avoid deformation of the outer case or other damaged, do not leave it exposed to direct sunlight for any length of time, also never leave it in a closed automobile.

Keep the Camcorder away from heaters.**Keep the Camcorder away from TV sets:**

Do not place the Camcorder near a TV set because it might impair the picture and sound quality of the recorded tape, and/or adversely affect the performance of the Camcorder.

Keep magnets away:

Never bring a magnet or magnetized object such as fluorescent lamps, motors, electric clocks and battery operated toys etc. close to the Camcorder because this could adversely affect its performance.

Keep the Camcorder away from areas with strong electric fields:

The picture may become distorted, when the Camcorder is used in places with strong electric fields, such as near TV or radio antennas.

Never put any object inside:

Never insert any object other than a video cassette into the Camcorder. If any object is dropped into it or if any liquid is spilled into it, consult qualified service personnel. Operating it with some foreign matter inside may cause fire or electric shock.

No fingers inside:

Touching internal parts of the Camcorder is dangerous and may cause serious damage to the Camcorder. Do not attempt to disassemble it. For internal inspection, adjustment or repairs, consult qualified service personnel.

Handle with care:

Never drop the Camcorder or expose it to strong physical shocks. Shocks during use may result in abnormal operation and performance.

Appearance of smear distortion:

Smear distortion is a peculiar characteristic of the CCD device. It appears as a bright vertical stripe on the screen when the Camcorder is aimed at spot lights or other bright lights and light reflecting objects. To avoid this problem, make sure not to aim the Camcorder at such strong light sources during shooting.

Cover the lens with the cap after shooting.**Keep the Camcorder away from strong light:**

Do not expose the Camcorder to strong light, because the heat from it may cause deformation or other damage.

When the Camcorder is not being used:

Remove the video cassette and turn the Camcorder off with the POWER switch.

Never place the Camcorder with the cassette compartment side facing down:

Never use the Camcorder with the cassette compartment facing down as this might cause uneven winding and slacking of the tape.

Cleaning the Camcorder:

- The body of the Camcorder is made of plastic materials. Never use benzine, thinner or other chemicals for cleaning, because the colour might be changed and the case surface might be damaged.
- Wipe the case and operation panel with a soft, clean cloth. For persistent stains, use a cloth moistened with mild detergent and water, and then wipe with a dry cloth.
- Clean the lens only with a blower brush (used for photo cameras) or a special lens cleaning tissue (used for glasses and cameras).

For battery pack:





Be sure to charge the battery pack before using it. Pay attention to the following points to avoid danger.

- Do not throw the battery pack into fire.
- Do not short-circuit the poles of the connector.
- Do not disassemble or reconstruct the battery pack.
- Use only the supplied AC adaptor to charge the battery pack.

Follow the instructions below to avoid damage to the battery packs or reduction of their service life.

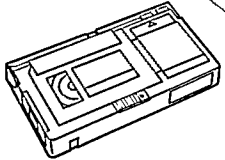
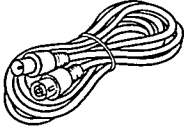
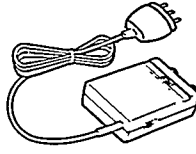
- Never subject the battery pack to strong shocks or drop it.
- Do not recharge a battery pack that is already fully charged.
- During operation of the system or during recharging, the battery pack may become warm however this does not pose any problem.
- The service life of a battery pack has its limits. If the operation time of a battery pack in spite of normal recharging become so short that its normal use for shooting is no longer possible, it should be replaced with a new one.

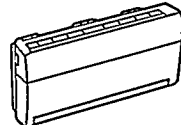
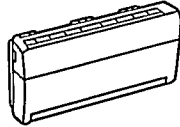
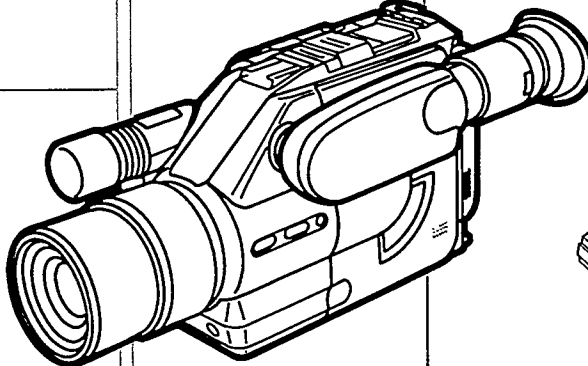
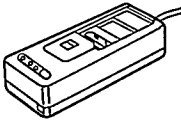
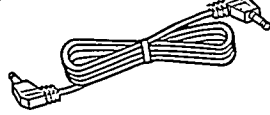
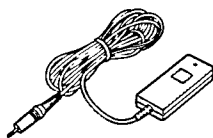
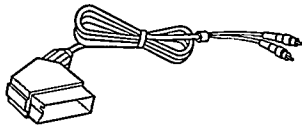
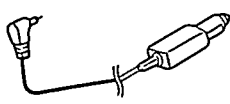
Camcorder accessories

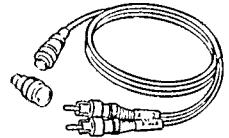
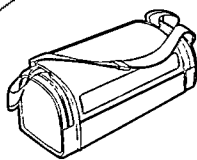
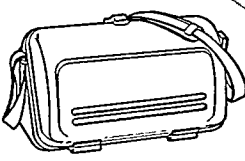
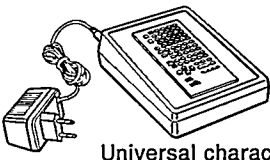
 <p>VHS-cassette adapter 22AV5146 (optional)</p>	 <p>DIN-DIN coaxial cable</p>	 <p>RF converter SBC5411 (mono) (optional)</p>  <p>Date/time back up battery CR2032 (supplied)</p>  <p>Battery pack SBC5217 (supplied)</p>	
 <p>Battery pack SBC5217 (optional)</p>	 <p>Camcorder</p>	 <p>AC adapter SBC5420 (supplied)</p>  <p>AV Eurocable SBC5509 (supplied)</p>	
 <p>Pause remote control unit 22AV5114 (optional)</p>		 <p>AV Eurocable SBC5509 (supplied)</p>	
 <p>Car battery cord SBC5422 (optional)</p>		 <p>Shoulder strap SBC5421 (supplied)</p>	
 <p>AV output cable SBC5507 (optional)</p>		 <p>Carrying soft bag 22AV5266 (optional)</p>	 <p>System carrying case 22AV5267 (optional)</p>  <p>Universal character generator 22AV5172 (optional)</p>

Controls and components

No.	Name	Page
①	Eyepiece corrector control	12
②	Eyecup	12
③	Power zoom control buttons (W/T)	15
④	POWER switch	14
⑤	Recording start/stop button	14
⑥	Shoulder strap holder	23
⑦	Electronic viewfinder (EVF)	7
⑧	Cassette compartment	13
⑨	FADE button	18
⑩	DATE/TIME selector	11
⑪	General operation controls	—
⑫	W. BALANCE button	16
⑬	High speed SHUTTER button	17
⑭	FOCUS button	15
⑮	EJECT button	13
⑯	White cap	16
⑰	Microphone	23
⑱	Accessory shoe	23
⑲	TRACKING/DATE/TIME SHIFT button	11, 19
⑳	TRACKING/DATE/TIME SET button	11, 19
㉑	RESET button	21
㉒	MEMORY DISPLAY button	21
㉓	Button battery compartment	10
㉔	Earphone socket (PHONE)	23
㉕	External microphone socket (MIC)	23
㉖	Grip belt	—
㉗	VIDEO output socket	20
㉘	RF DC output socket	20
㉙	AUDIO output socket	20
㉚	Battery eject button (BATT. EJECT)	8

General Operation Controls

No.	Name	Page
⑳	Tripod receptacle	23
㉑	FOCUS +/- buttons	15
㉒	REMOTE control socket	23
㉓	DC input socket (DC IN)	9
㉔	PAUSE/STILL button	19
㉕	PLAY button	19
㉖	REV/⏪ button	14
㉗	CAMERA/VCR selector cover	14
㉘	▶/FWD button	14
㉙	STOP button	19

Indications in the electronic viewfinder (EVF)

The following indications are displayed in the electronic viewfinder (EVF) to inform you of the conditions of the Camcorder.

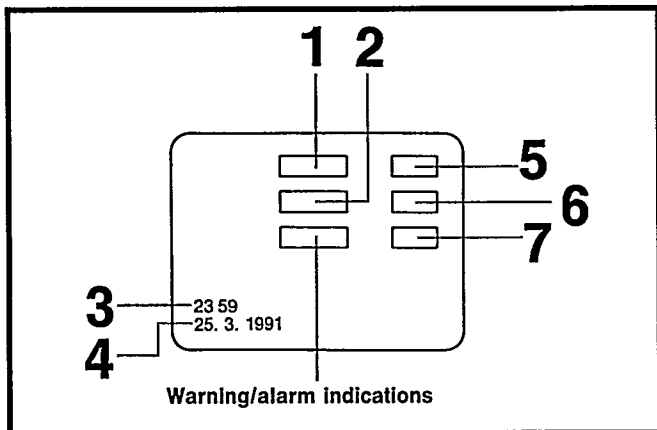

Warning/alarm indications

	There is little battery power left. The Camcorder will be turned off in a few minutes. Replace the battery pack by a fully recharged one.
	It is impossible to record because the erasure prevention tab of the cassette is not intact.
	During recording, the tape has almost reached its end. Replace the tape with a new one. The indication will remain lit when the tape has reached its end.
	When condensation has formed inside the Camcorder, the "DEW" indication will flash and a few seconds later, the unit itself turns off.
	Video head clogging. (See page 3.)
	When the battery for title memory and auto date is not inserted, the indication will flash for 10 seconds after the Camcorder is turned on.

1. **Remaining battery power indication**
E--F : The "--" indications begin to disappear from right to left as the power of the battery pack weakens.
 2. **Counter indications**
0:00.00 : Tape counter
M0:00.00 : Tape counter with memory indication
 3. **Time indication**
 4. **Date indication**
 5. **Tape running indications**
REC : Recording mode
PAUSE : Recording pause mode
▷ : Play mode, Retake (In forward direction)
|| : Still mode
▷▷ : Fast forward/cue mode
◁◁ : Rewind/review mode, Retake (In reverse direction)
 6. **White balance indications**
—WHITE— : Manual mode, during setting
W.SET : Manual mode, setting is finished
No display : Auto mode
 7. **High speed shutter mode indications**
No display : 1/50 sec. (normal)
1/120 : 1/120 sec.
1/250 : 1/250 sec.
1/500 : 1/500 sec.
1/1000 : 1/1000 sec.
1/2000 : 1/2000 sec.
1/4000 : 1/4000 sec.
Focus mode indication
MF : Manual focus mode
- Some of the above indications may light up alternately at the same place in the EVF to indicate the corresponding operating condition or warnings.

Power supply systems

Attaching the battery pack

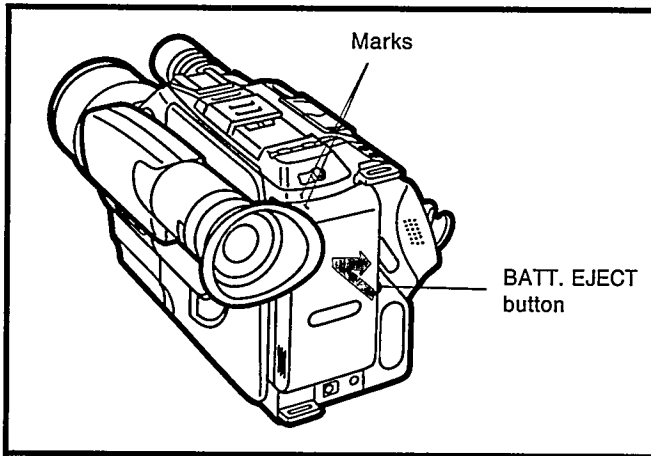

- 1 Align the grooves of the battery pack and the Camcorder.
- 2 Insert the battery pack until it locks with a click.
 - To remove the battery pack, press the BATT. EJECT button and slide the battery pack in the opposite direction of that in operation step 2.

CAUTIONS:

- Wait about 10 seconds after turning the Camcorder off before removing the battery pack.
- If the battery pack is removed during recording or playback, the tape remains wound around the video head cylinder and could become damaged.

Charging the battery pack

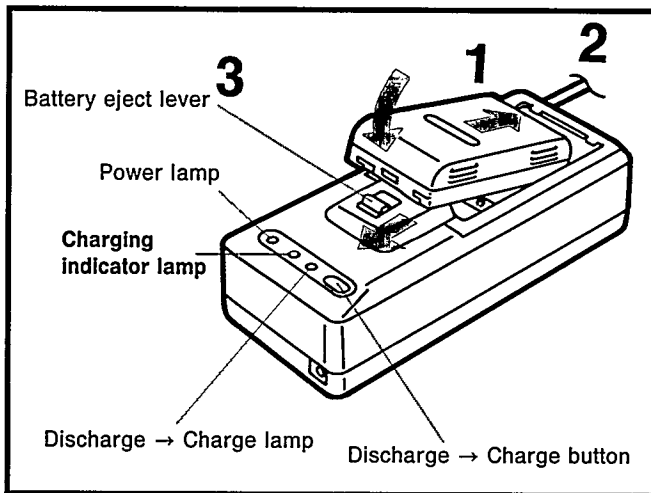

- 1 Attach the battery pack.
- 2 Connect the AC adaptor to the mains.
- 3 When the charging is completed, slide the battery eject lever in the direction of the arrow and remove the battery pack.

Notes:

- The charging takes about 60 minutes.
- The Camcorder can be used continuously for approx. 45 minutes with a fully charged battery pack.

■ Charging indicator lamp

Lights while charging is taking place and goes out when charging is finished.

■ Discharge → Charge function

The battery pack can be recharged for repeated use. However, if it is recharged repeatedly while there is still some charge left, its charging capacity will be gradually reduced. Therefore, if you often need to recharge semi-discharged battery packs, attach the battery pack to the AC adaptor, connect the AC adaptor mains, and press the Discharge → Charge button to completely discharge the battery pack. (The Discharge → Charge lamp will light up, and when the discharging is finished, the charging indicator lamp will light up instead.) This will increase the charging capacity and extend the operating life of the battery pack. Therefore, if the operating life of the battery pack becomes noticeably shorter, refresh it. (It is recommended to refresh the battery pack approx. once every five rechargings.)

The function of a battery pack is based on a chemical reaction. Use it according to its characteristics.

- Charge the battery pack with in a temperature range of 10°C – 35°C. If charged at lower temperatures, the chemical reaction cannot take place optimally, causing the performance of the battery pack to deteriorate. At higher temperatures, the battery pack cannot be charged completely.
- Store the battery pack in a cool and dry place. If exposed to high temperatures for a long time, the battery life will be shortened and the self-discharging process will be increased.
- Charge the battery pack before using it because self-discharging may occur if it has not been used for a long period of time.
- When not using the battery pack, remove it from the Camcorder or the AC adaptor.

Charging confirmation marker on the battery pack

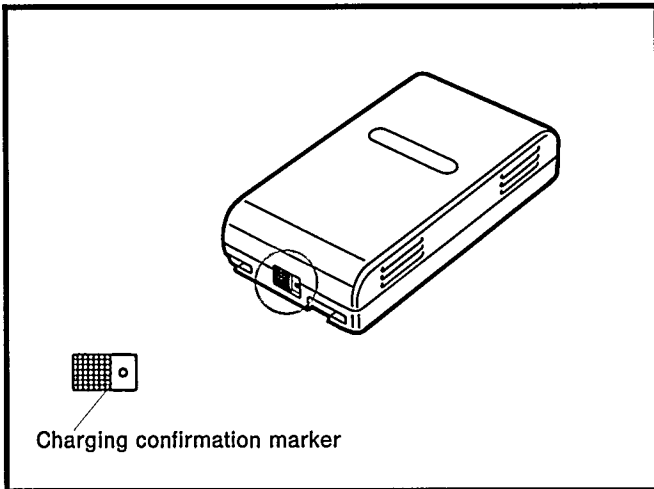

This marker makes it convenient to distinguish between charged and discharged battery packs. For example, visible dot means charged battery pack, and no dot means discharged battery pack.

AC adapter (SBC5420)

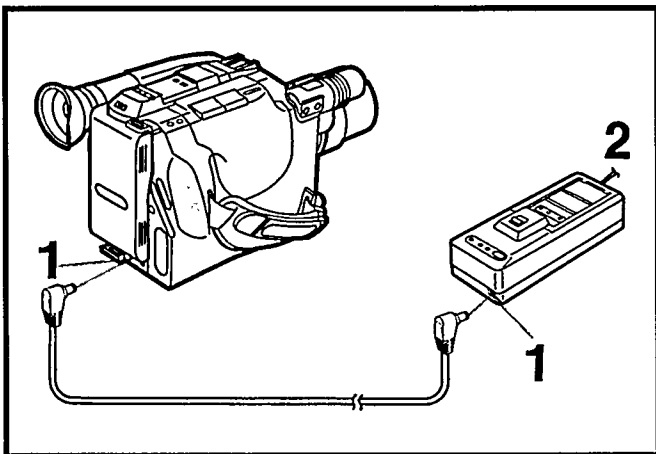

1 Connect the power supply cable from the DC output socket on the AC adapter to the DC input socket on the Camcorder.

2 Connect to the mains.

Note:

When a battery pack is attached to the AC adaptor, the Camcorder cannot be supplied with power.

Car battery cord (SBC5422)

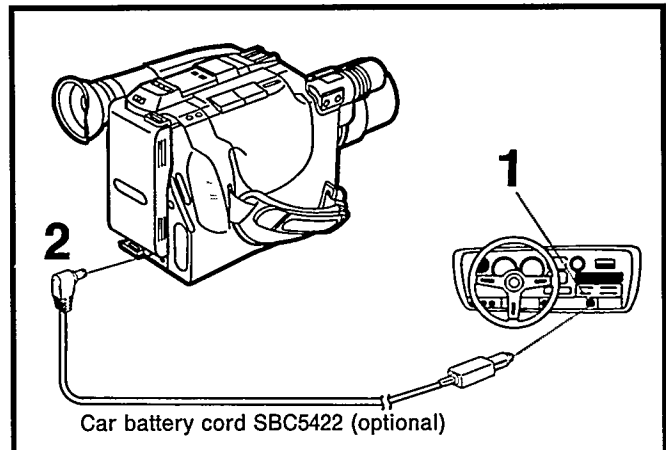

- 1** Start the engine and insert the car battery cord into the cigarette lighter socket.
- 2** Connect the other end to the DC input socket on the Camcorder.

Notes:

- The car battery cord can only be used with 12 V DC negative grounded vehicles.
- Do not start the car engine while the Camcorder is powered by the car battery.

Setting the date and time

How to insert the battery for the clock operation

1

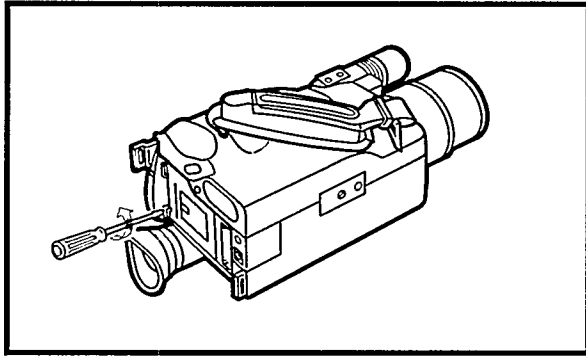

Remove the lid.

2

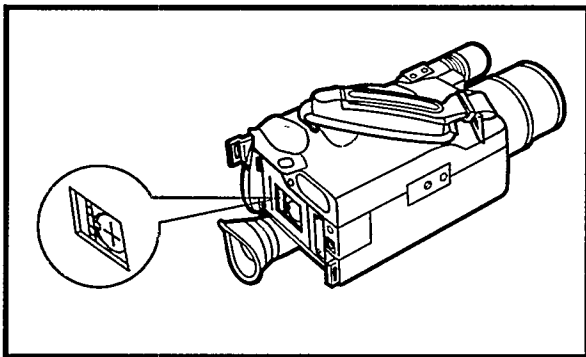

Insert the "CR2032" size battery with polarities (+ and -) aligned correctly and then replace the lid.

Notes:

- This battery is necessary for the date and time, to be memorized by the Camcorder.
- If the battery is not inserted or if it is exhausted, the indication "BACKUP" in the EVF will flash for approximately 10 seconds when turning the Camcorder on.
- When replacing the battery while the time and date indications are still correct, connect the Camcorder to the AC adaptor for the duration of the battery replacement so that the time will remain unchanged.

CAUTIONS FOR BATTERY REPLACEMENT

- The life of the battery is about one year. Inspect and if necessary, replace the battery once a year.
- Load the new battery with its polarities (+ and -) aligned correctly.
- Remove spent battery immediately and dispose of it.
- Do not try to short-circuit, recharge or heat the battery and do not throw it into a fire.

Setting of the date and clock

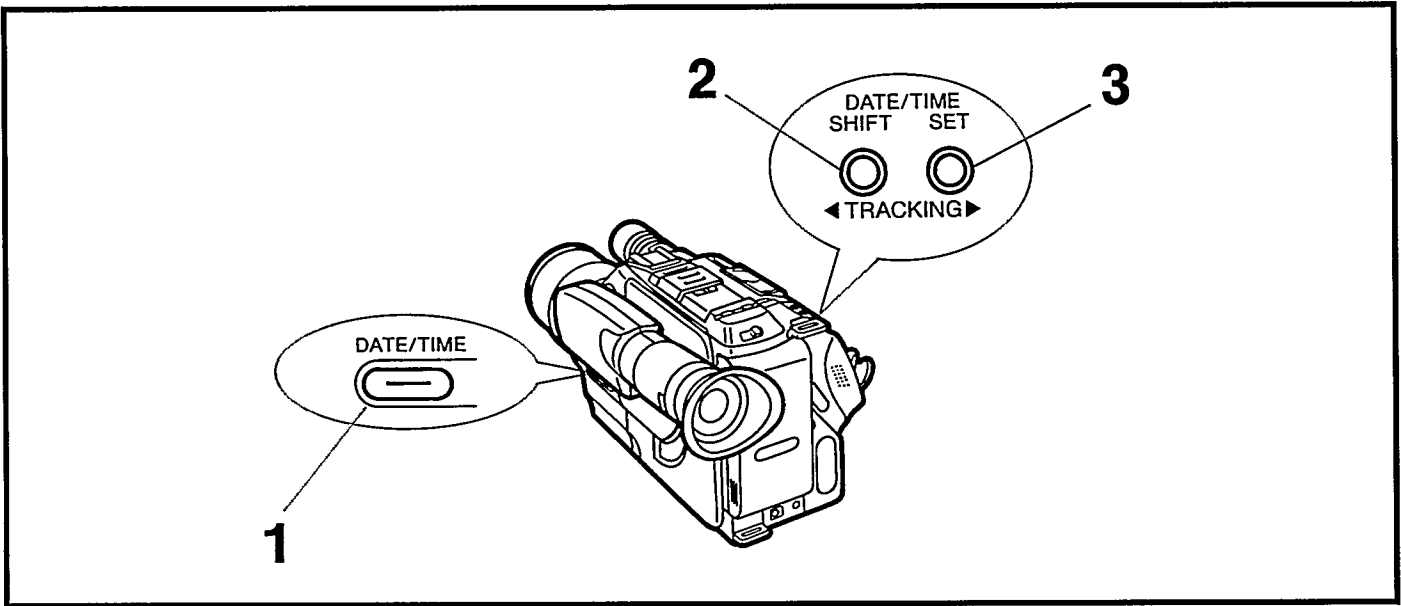

1 When the DATE/TIME selector button is pushed, the indication shown below will appear in the EVF.

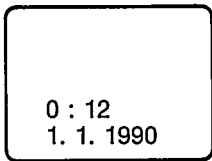

- If no battery is inserted, the indication "BACKUP" will light up.

2 When the SHIFT button is kept pressed for more than about 2 seconds, the "Year" portion will start to flash. Then, at every press of the SHIFT button, the items to be set will flash in the following sequence.

Year → Month → Date → Hour → Minute → Year →

3 When the SET button is pushed, the flashing portion displayed will be changed in the following sequence.

YEAR: 2089 → 1990 → → 2089 → 1990 → ...
 MONTH: 1 → 2 → → 12 → 1 → ...
 DATE: 1 → 2 → → 31 → 1 → ...
 HOUR: 0 → 1 → → 23 → 0 → ...
 MINUTE: 00 → 01 → → 59 → 00 → ..

- Repeat procedures 2 and 3 until all items have been set.
- Once the time and date are set, press the SHIFT button in response to a precise time signal so that the clock may begin to function.

Recording the date/time Indications

When the DATE/TIME selector is pushed repeatedly, the indications will change in the following sequence:

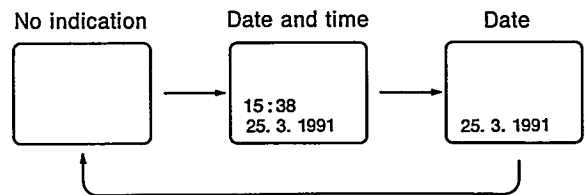

Electronic viewfinder (EVF)

Pulling out the EVF

Keep the EVF in its fully extended position during shooting.

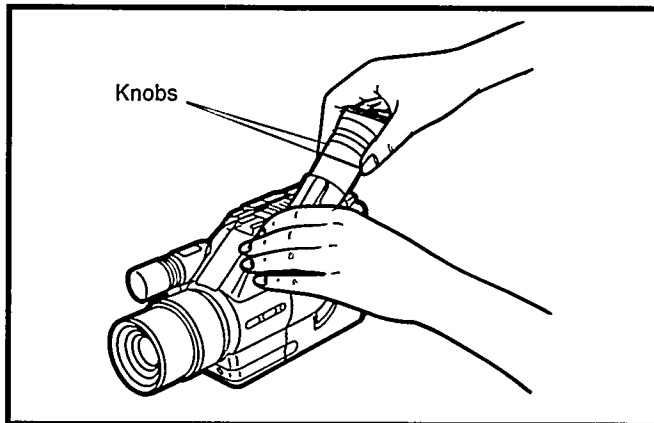

Notes:

- When pulling out the EVF, do not hold it by the eyecup.
- Do not apply any pressure on the EVF except for pulling it out and pushing it back in again.
- Be sure to retract the EVF after shooting.

Removing and attaching the eyecup

The eyecup can be removed for cleaning or viewing the EVF with the left eye.

Removing the eyecup

Pull up the eyecup by the line and turn it counterclockwise.

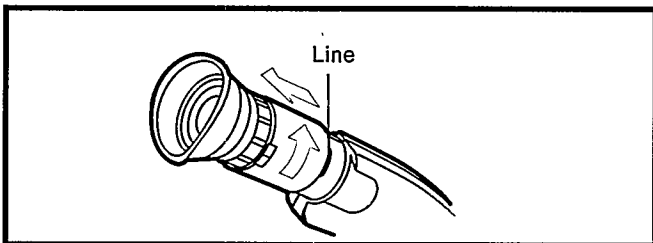

Attaching the eyecup

Insert the eyecup and turn it clockwise.

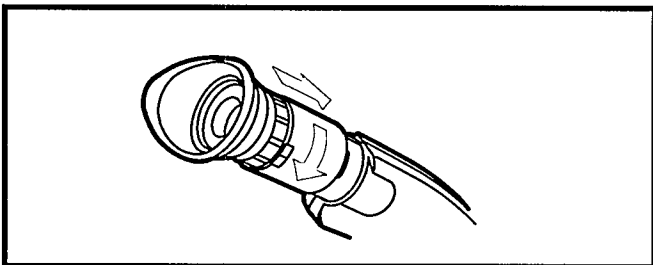

Eyepiece corrector

With this control the eyepiece can be adjusted to the eyesight.

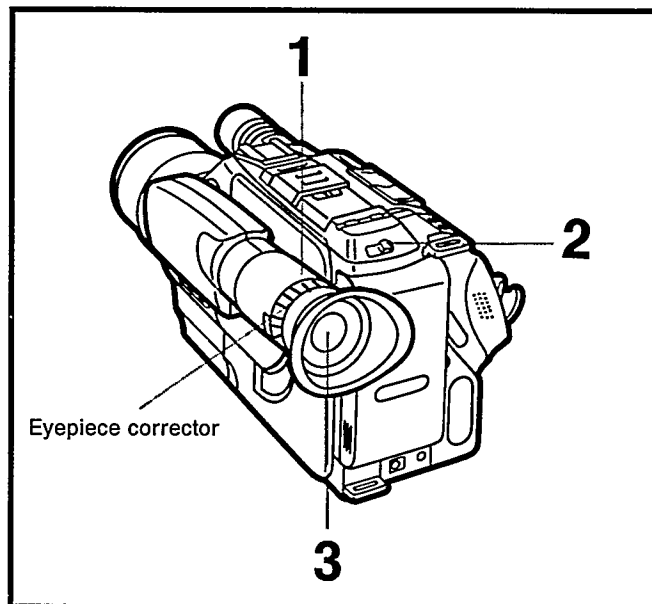

- 1 Pull out the EVF to its fully extended position.
- 2 Turn the Camcorder on.
- 3 Adjust the eyepiece corrector until the indications in the EVF are clearly visible.

Attaching the filter

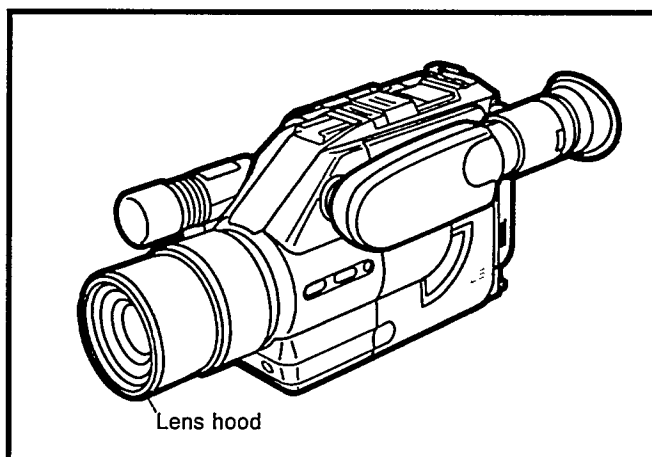

- 1 Turn the lens hood counter-clockwise to remove the lens hood.
- 2 Attach the filter.

Note:

A 43 mm diameter filter can be used.

Video cassette

Inserting a video cassette

Before inserting the cassette

Make certain before inserting the cassette that the tape is not slackened. If there is any slack, turn the gear on the cassette in the direction of the arrow to take up slack.

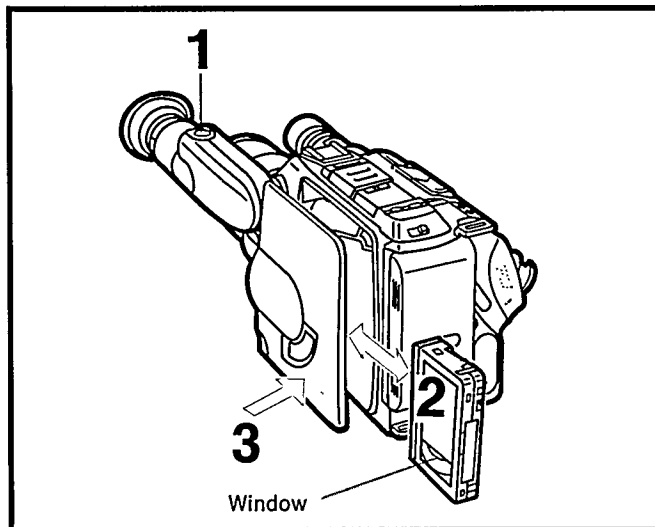
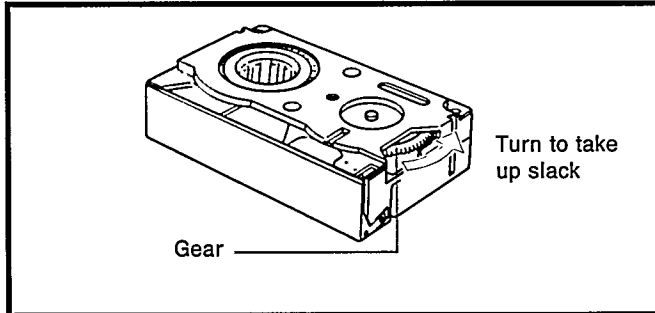

- 1 Turn the EVF fully toward the lens and press the EJECT button.
- 2 Insert the video cassette into the cassette compartment with its window facing outside.
- 3 Push the cassette compartment cover inward, until it locks with a click, then turn the EVF back.

Removing a video cassette

- 1 Turn the EVF fully toward the lens and press the EJECT button.
- 2 Pull out the video cassette.
- 3 Push the cassette compartment cover inward, until it locks with a click, then turn the EVF back.

Note:

Use VHS-C video cassettes only.

Notes:

- Recording onto prerecorded tapes automatically erases the previously recorded video and audio signals.
- An inverted cassette cannot be inserted.
- Do not load and unload the cassette repeatedly without allowing the tape to run at all. This will slacken the tape and thereby damage it.
- The cassette is equipped with a safety tab to prevent accidental erasure. When the tab is removed, recording is impossible. If you wish to record on a cassette whose tab has been removed, use adhesive tape to reseal the slot.
- To avoid excessive exposure to dust and fingerprints, do not open the front tape cover.

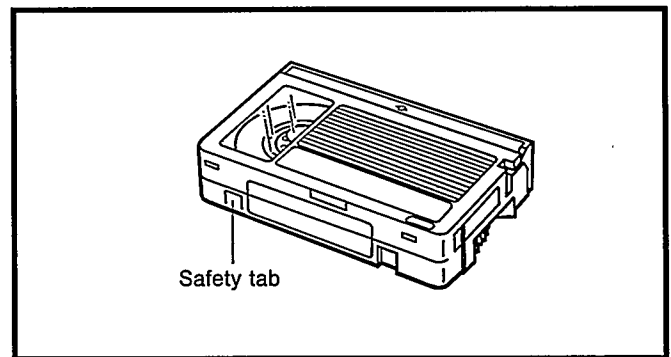

Storage of cassettes

- Avoid exposing the cassettes to direct sunlight. Keep them away from heaters.
- Avoid storing the cassettes in humid or dusty places.
- Do not drop the cassettes. Do not expose them to violent vibrations or shocks.
- Do not expose the cassettes to strong magnetic fields (near a motor, transformer or magnet).
- Place the cassettes in cassette cases and position them vertically.

Camera recording

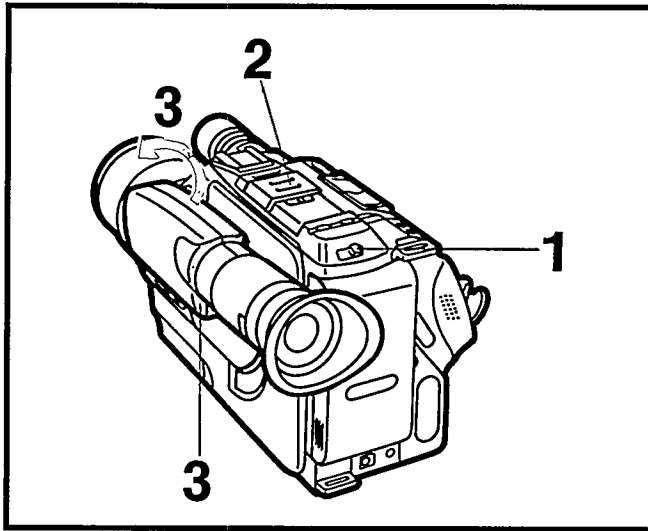

To start recording

- 1** Slide the POWER switch to the right to turn the Camcorder on.
- 2** Slide the CAMERA/VCR selector cover to "CAMERA".
- 3** Turn the EVF fully toward the lens, press the EJECT button and insert a video cassette with the erasure prevention tab intact.
 - After a few seconds, the Camcorder will be in the recording pause mode.
- 4** Place the Camcorder in the shooting position.

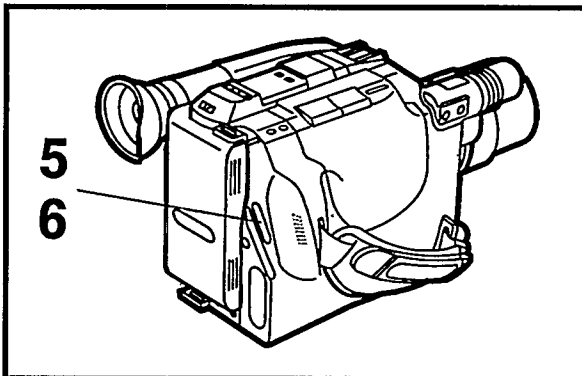

- 5** Press the recording start/stop button.
 - The recording starts.
- 6** Press the recording start/stop button again to stop the recording temporarily (Recording pause mode).

To stop recording

- 1** Put the Camcorder in the recording pause mode.
- 2** Slide the POWER switch to turn the Camcorder off.

Rec review

For checking the last few seconds of recorded scenes.

- 1** Put the Camcorder in the recording pause mode.
- 2** Press the REV/⏮ button.

Retake

For checking recorded scenes.

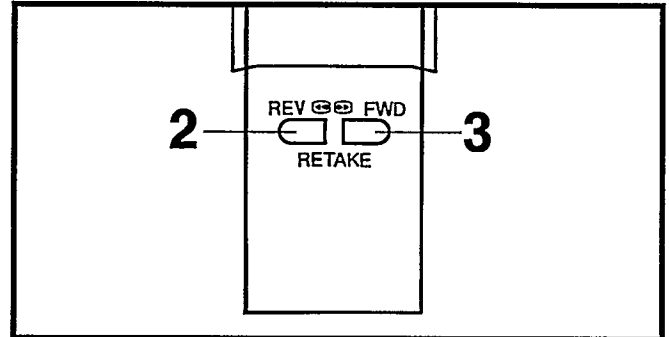

- 1** Put the Camcorder in the recording pause mode.
- 2** Keep the REV/⏮ button pressed to play back a scene at high speed in reverse direction.
 - The sound is not reproduced.
- 3** Keep the ⏭/FWD button pressed to play a scene at normal speed in forward direction.
 - The sound is reproduced.

Recording lock function

This function ensures smooth scene-to-scene continuation in assemble recording. Even if the POWER switch is turned off, the tape remains loaded around the head cylinder. The recording lock mode is activated by setting the POWER switch off during recording pause.

- If the unit remains in the recording pause mode for more than 6 minutes, it will automatically turn itself off to protect the tape and save battery power. (The tape remains wound around the head cylinder. This condition is called "Recording Lock".) To use the Camcorder again, slide the POWER switch to the right to turn on.
- If the recording lock mode continues for more than 48 hours, it will be cancelled and the unit will be turned off.

Advanced videography techniques

Focus

Continuous auto focus

For continuous automatic focus adjustment, turn the Camcorder on and set the CAMERA/VCR selector cover to "CAMERA".

- The focus will automatically be adjusted to the subject in the center of the EVF.

Manual focus

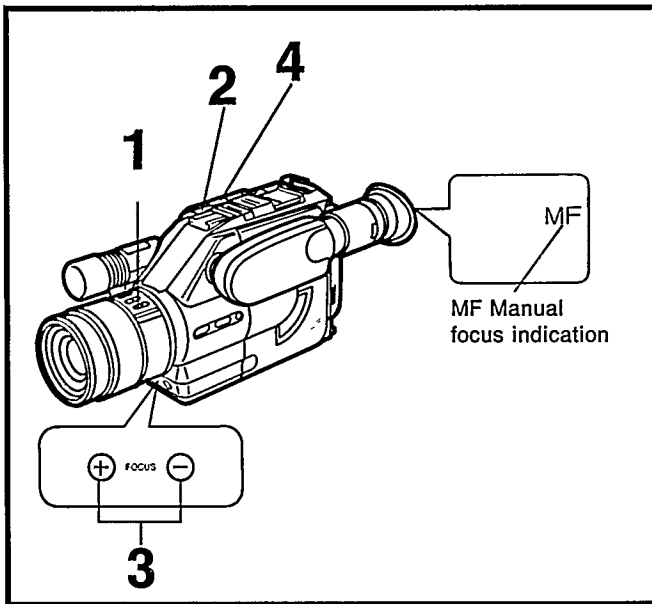

- 1 Press the FOCUS button.
 - The indication "MF" will appear in the EVF.
- 2 To zoom in on an object, press the "T" zoom button.
- 3 Adjust the focus with the focus "+" or "-" button.
- 4 To zoom back from an object to show more of it, press the "W" button.
 - After putting the Camcorder into the recording lock mode, or setting the CAMERA/VCR selector cover to a position other than "CAMERA", repeat operation steps 1 to 4.

Macro close-up

For close-up shots of small objects or photos.

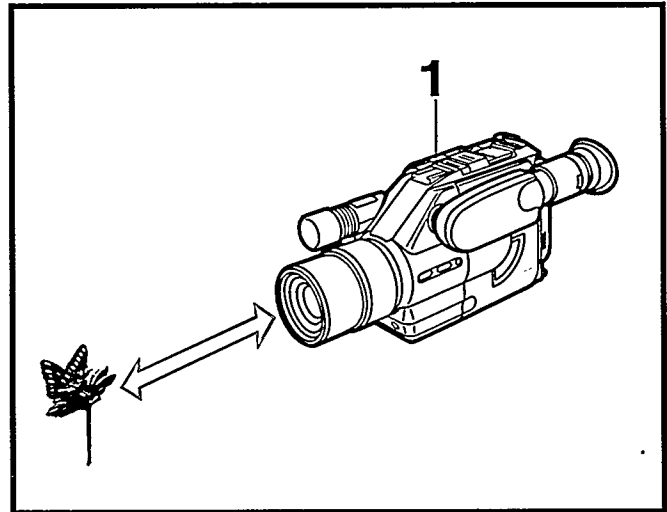

- 1 Keep the "W" power zoom control button pressed.
 - The focus will be adjusted up to a minimum distance of 6 mm between lens and object.
 - After focusing all the way to the wide-angle position, the focus can be adjusted simply by approaching the subject.
 - The focus can be adjusted both in the AUTO and MANUAL mode.

Practical hint for shooting

- To change the scale of the object, change the distance from the object.
- As the depth of field is very small in macro shooting, even slight camera movements can cause the object to be out of focus. Therefore, it is recommended to use a tripod.
- When the "T" power zoom control button is pressed to zoom in on an object, the focus can be adjusted within a range of more than 0.7 m from the object.

Cautions

The auto focus system will not provide stable and accurate focus adjustment if you are shooting:

1. A subject behind dirty glass.
2. Shiny surfaces.
3. A subject with a part of it near and another part far from the Camcorder.
4. An oblique subject.
5. A subject with horizontal stripes.
6. A flat surface, e.g. a white wall.
7. With the macro close-up function, special lenses or filters.
8. A fast-moving subject.
9. A subject having a dark surface.

In these cases, use manual focusing.

White balance

Auto white balance

This adjustment is necessary to assure natural colour rendition.

For continuous automatic white balance adjustment, just turn the Camcorder on. This setting will automatically provide well-balanced natural colour rendition under almost any shooting condition.

Manual white balance adjustment

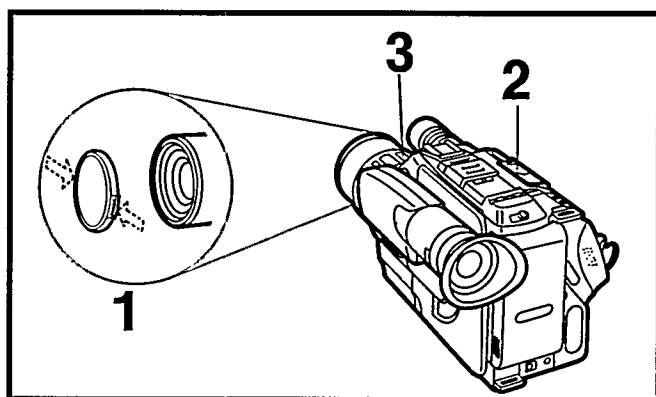

- 1** Attach the white cap to the lens.
- 2** Keep pressing the "T" button of the power zoom control button until the screen in the EVF becomes completely white.
- 3** Keep the W. BALANCE button pressed for more than 1 second.
The "WHITE" indication in the EVF informs about the state of the adjustment:
Flashing slowlyNot set
Flashing rapidlyDuring setting
The indication "W. SET" is lit ...Setting is finished

- **How to use the white cap**
If there is only one light source, attach the white cap to the lens for the manual white balance adjustment. If there are several light sources or if the illumination is weak (indoor, etc.), remove the white cap from the lens and point the Camcorder at a purely white object, such as white paper, and then adjust the white balance.
- **Automatic recall of previous white balance setting**
When the POWER switch of the Camcorder is turned off and later on again, the "WHITE" indication will flash slowly, however, the last previous white balance setting is still maintained. However, to ensure best possible colour reproduction, adjust the white balance anew as explained above. It is also maintained during playback, rec review and retake. However, the previous white balance setting will no longer be maintained when the AC adaptor is turned off or the battery pack is removed from the Camcorder.

- When moving the Camcorder from indoor to outdoor or vice versa, be sure to adjust the white balance anew, as colour of the light has changed considerably.

Cautions

The auto white balance adjustment may not be accurate when:

1. When shooting under mercury-vapor, sodium or some types of fluorescent lamps.
2. When intense lighting is used, e.g. from a halogen lamp, or when the colour temperature of the light source is low.
3. When shooting a subject of a single colour or a subject in front of a single-colour background.
4. When shooting outdoors at sunrise or sunset.
5. When using a gray filter (ND) or other special filters.
6. When using a conversion lens.
7. When using the Camcorder under weak illumination.

In these cases, use the manual white balance adjustment mode.

If it is moved from outdoors to indoors during recording, the picture will initially take on a slightly reddish cast but it will gradually regain its natural colours.

High speed shutter

A range of different shutter speeds make possible videographing of scenes with fast movements.

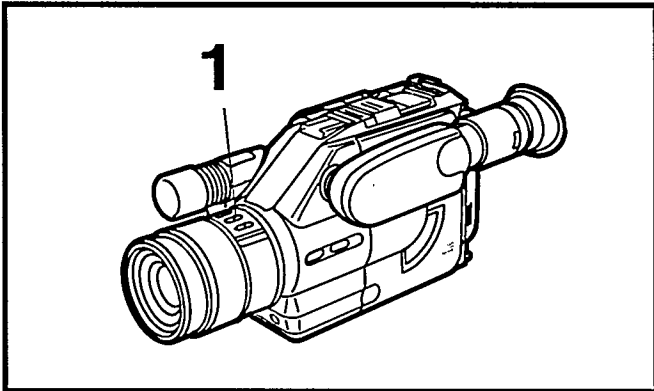

- 1** By repeatedly pushing the SHUTTER button, the shutter speed can be changed as follows:
 (No indication) : 1/50 sec. (normal)
- | | |
|--------|---------------|
| 1/120 | : 1/120 sec. |
| 1/250 | : 1/250 sec. |
| 1/500 | : 1/500 sec. |
| 1/1000 | : 1/1000 sec. |
| 1/2000 | : 1/2000 sec. |
| 1/4000 | : 1/4000 sec. |

For playback

When scenes recorded with high shutter speed(s) are later played back on a VCR equipped with the playback functions super still and super fine slow motion, etc., still and slow motion pictures with very sharp contours and full details can be obtained.

Cautions

The following conditions are required for shooting with the high speed shutter function:

- The subject must be brightly lit, with little shade, under sunlight or some other illumination of more than 300 lux.
- If shooting under the illumination produced by fluorescent lamps, the picture will be adversely influenced by flickering.
- If the picture is played back in the normal playback mode, the movements may appear to be not very smooth.
- The playback picture will be slightly darker than the picture recorded without using the high speed shutter function.

Zooming

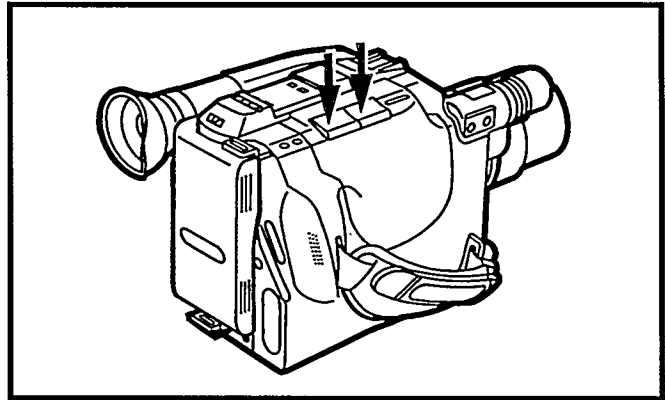

- 1** Press "T" for zooming in and "W" for zooming out.

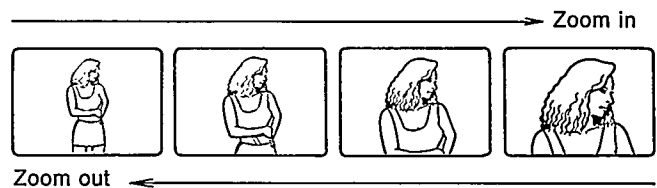

Fade-in and Fade-out

Fade-in

Fade-In is used, for example, at the beginning of a performance.

After recording the title, gradual fading-in of the first scene is very effective.

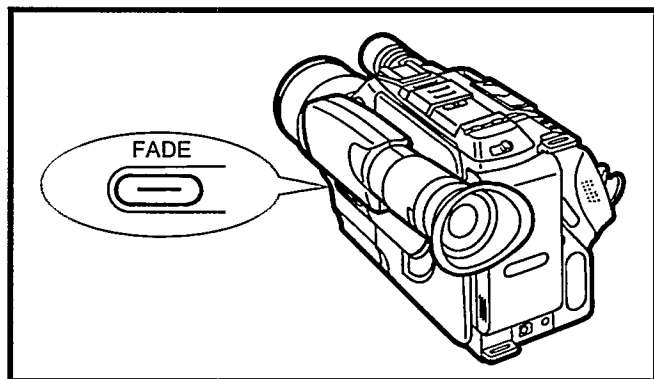

Fade-in →



- 1** With the Camcorder in the recording pause mode, keep the FADE button pressed.
- 2** After the picture has disappeared in the EVF, press the recording start/stop button.
- 3** 3 seconds later, release the FADE button.
 - The picture will appear gradually.

Fade-out

Fade-out is used to give a scene a soft ending or for a smooth fade-out/fade-in transition from one scene to another.



← Fade-out

- 1** During recording, press the FADE button at the point where you want to fade out.
- 2** After the picture has disappeared, press the recording start/stop button to stop the recording.
- 3** Release the FADE button.

Playback

Preparation

- Insert the recorded cassette.
- Turn the Camcorder on and set the CAMERA/VCR selector cover to "VCR".

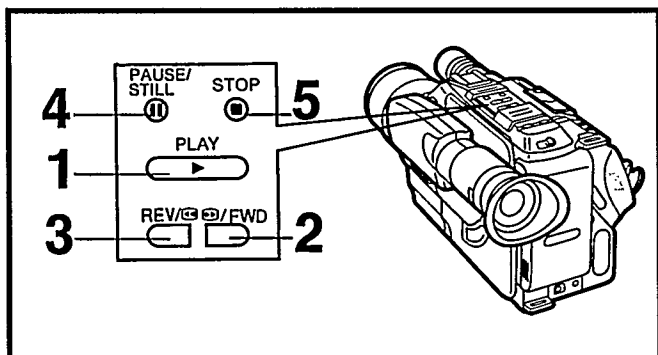

Operations

- 1** Playback : Press the PLAY (▶) button
- 2** Cue playback : Keep the ▶/FWD button pressed during playback.
- 3** Review playback: Keep the REV/◀ button pressed during playback.
- 4** Still playback : Press the PAUSE/STILL (||) button during playback.
 - To return to normal playback, press this button again.
- 5** Press the STOP button (■) to finish playback.

Fast forward

Press the ▶/FWD button to rapidly wind the tape forward.

Rewind

Press the REV/◀ button to rapidly rewind the tape.

Tracking control

When picture is distorted by noise bars during playback, the tracking needs to be adjusted.

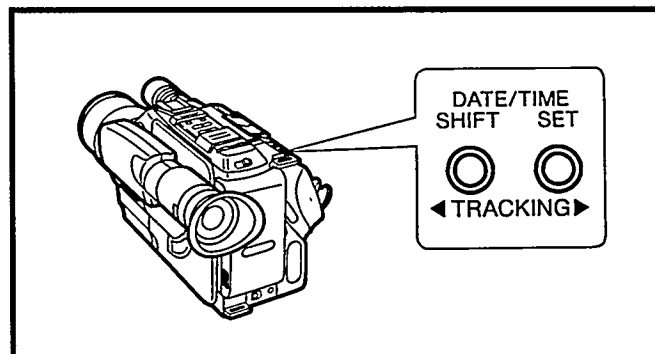

- 1** Press both the TRACKING ◀ and ▶ buttons simultaneously.
- 2** Adjust the tracking with the TRACKING ◀ or ▶ buttons.
 - When playing back a tape which has been recorded on another Camcorder, it may not be possible to completely eliminate this distortion.
 - Noise which takes the form of horizontal bars appears in the cue, review and still playback modes. This is not an indication of a malfunction.

Notes:

- *The sound will be played back only during normal playback.*
- *Playback: The tape will be rewound automatically when it reaches its end.*
- *Fast Forward: The tape will stop automatically when it reaches its end.*
- *Rewind: The tape will stop automatically when it reaches its beginning.*
- *Still playback: If the Camcorder is left in this mode for about 6 minutes, it will switch over to the stop mode, to protect the tape and video heads.*

Playback via TV set (connections)

TV set with AV input

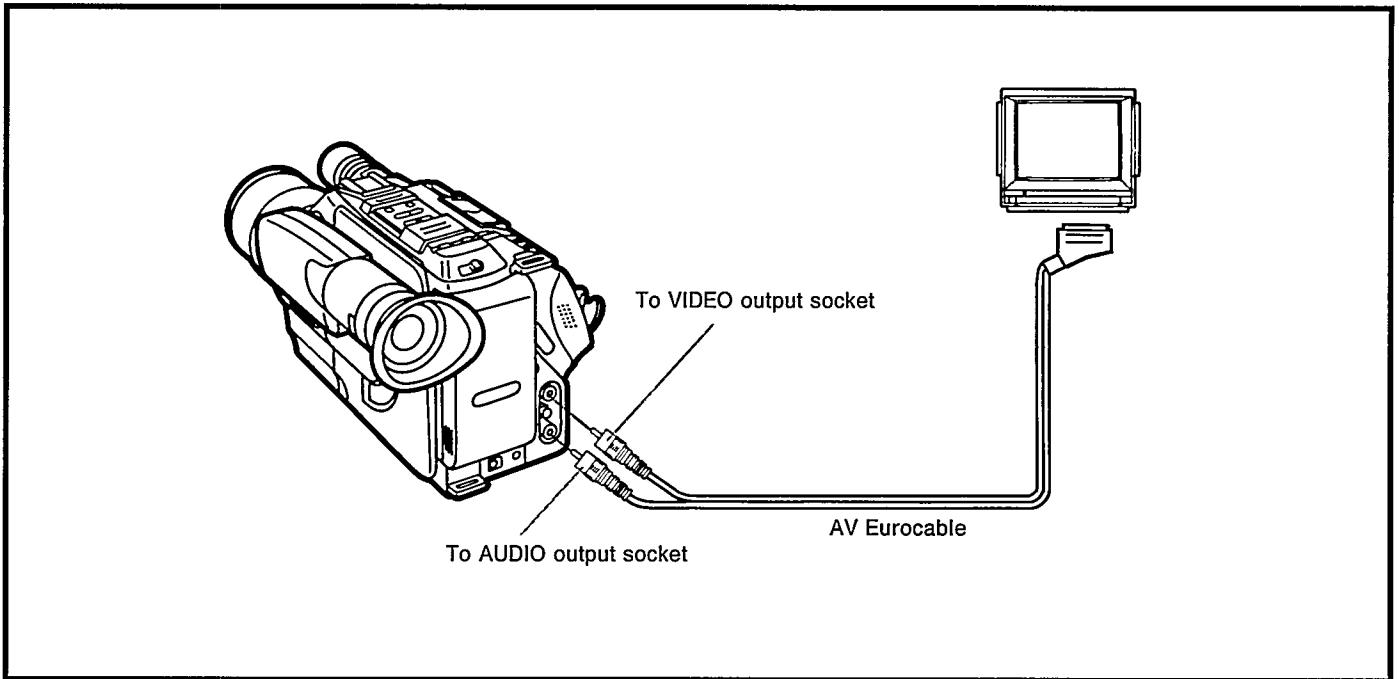

TV set without AV socket

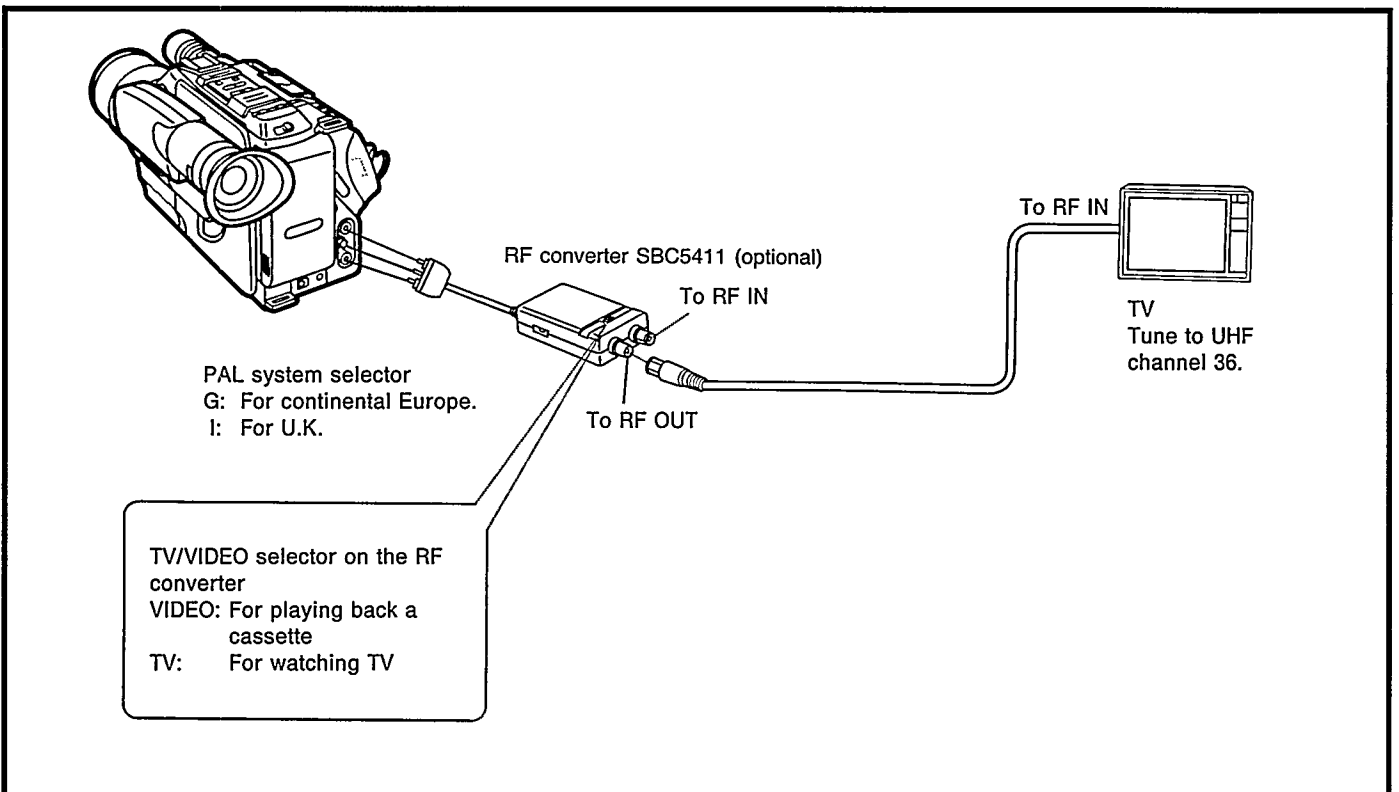

Playback on a table type VCR

Use the cassette adaptor 22AV5146

The VHS-C compact video cassettes recorded with the Camcorder can be played back with a standard VHS VCR by using the optional cassette adaptor. (A compact video cassette installed in the cassette adaptor is fully compatible with a standard VHS VCR for both recording and playback.)

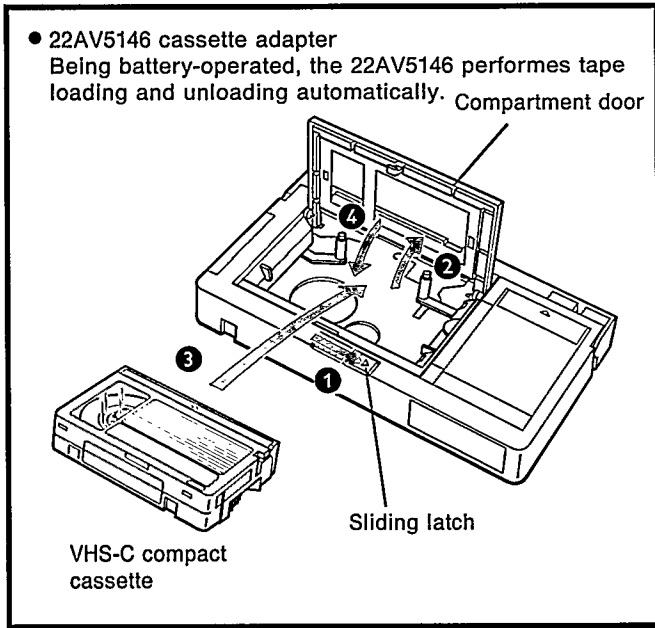

For more details refer to the instruction manual of the 22AV5146.

Note:

During special-effects playback (slow motion, still frame, etc.) the picture may vibrate or noise bars may appear on the screen.

Inserting the battery into the cassette adapter

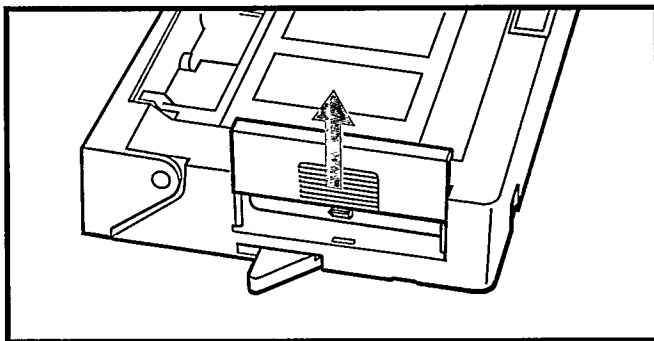

Remove the battery cover by sliding it up. Install one "R6" battery and reattach the cover.

Other functions

Memory search function

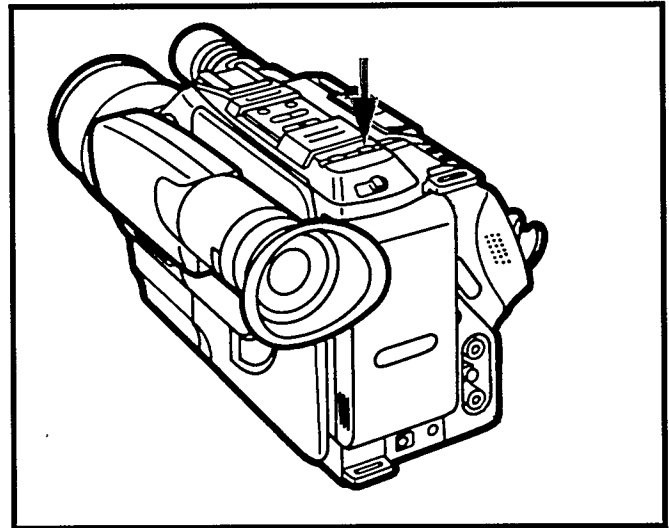

- 1 Press the RESET button at the desired point.
 - The tape counter is reset to "0:00.00".
- 2 Press the MEMORY/DISPLAY button.
 - The "M" indication appears in the EVF.
M 0:00.00
- 3 After pressing the STOP button, press the REV/⏮ button.
 - The tape will stop automatically at about the point where the tape counter reads "M0:00.00".

Tape counter indication

At every push of the MEMORY/DISPLAY button, the counter indication will change as follows:

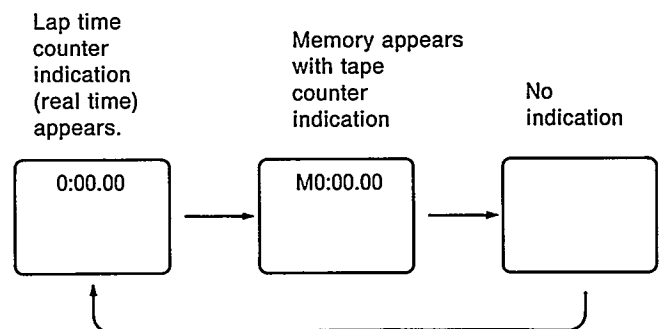

Assemble editing

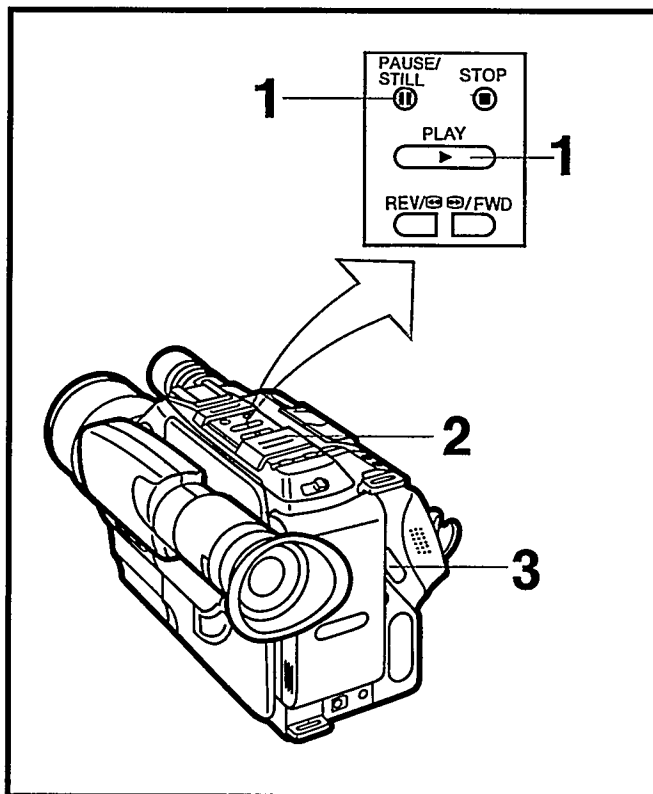

Preparation

- Insert a video cassette with the erasure prevention tab intact.
- Set the CAMERA/VCR selector cover to "VCR".

Operations

- 1 Play back the tape to locate the point where the new recording is to be joined (Assemble Editing), and press the PAUSE/STILL button at the desired point.
- 2 Set the CAMERA/VCR selector cover to "CAMERA".
- 3 Press the start/stop button to start shooting the new scene.

Dubbing (copying)

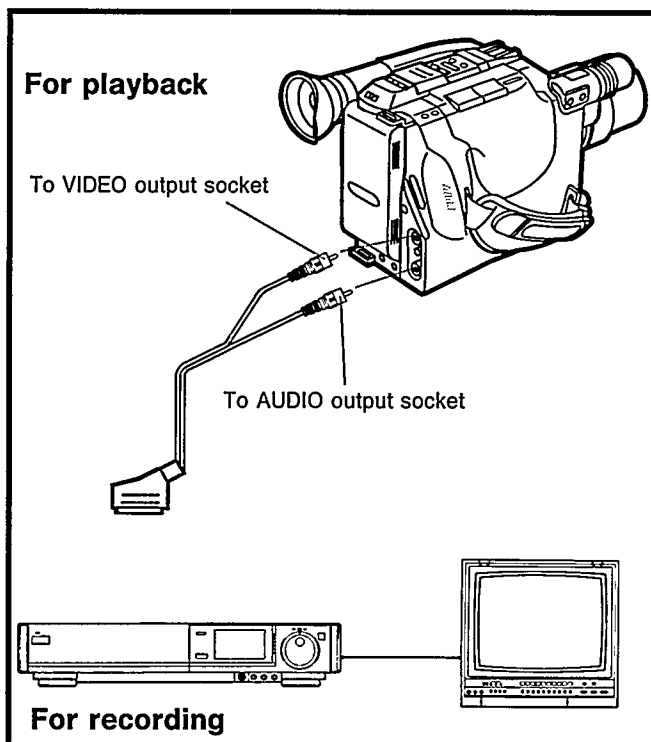

Operations

- 1 Press the PLAY button on the Camcorder to start playback.
- 2 Press the RECORD button on the VCR to start recording.

Note:

The picture quality of a copied tape is inferior to that of the original tape.

- For details, refer to the operating instructions of the recording VCR.

Syncro editing

Use the syncro editing cable (optional) to connect the remote control socket on the Camcorder with the syncro edit socket on the recording VCR.

- If the recording VCR is equipped with syncro-edit function, this Camcorder can be operated via the recording VCR, i.e. playback start and stop of the Camcorder will be synchronized with the recording start and stop on the VCR.
- For details, refer to the operating instructions of the recording VCR.

Accessories, etc.

Shoulder strap

1

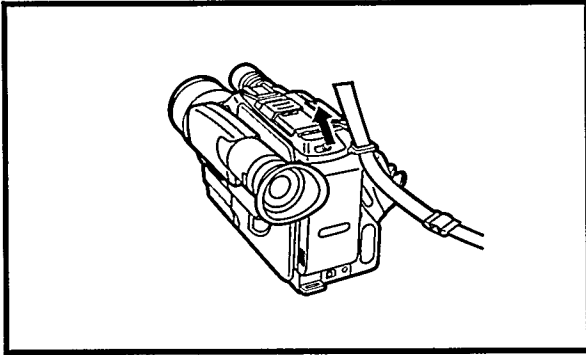

Pass the end of the shoulder strap through the slit of the shoulder strap holder on the upper part of the rear of the Camcorder.

2

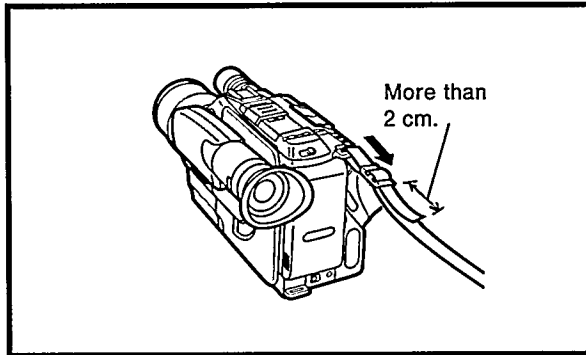

Securely attach the end of the strap.

3

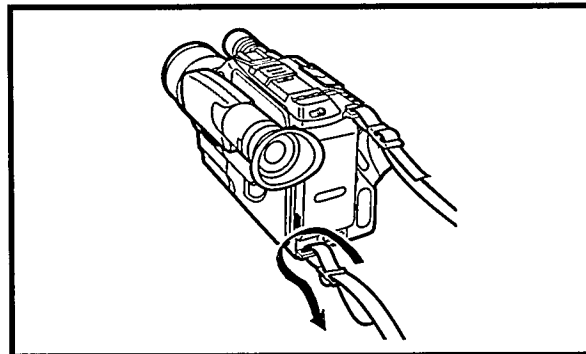

Attach the other end of the shoulder strap at the lower part of the rear of the Camcorder in the same way as mentioned above.

Tripod mount

Bottom side of the Camcorder

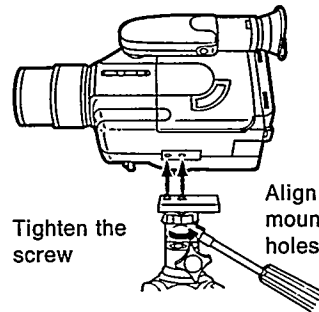

- Place the tripod on a stable surface, with its legs fully spread.

Other connections

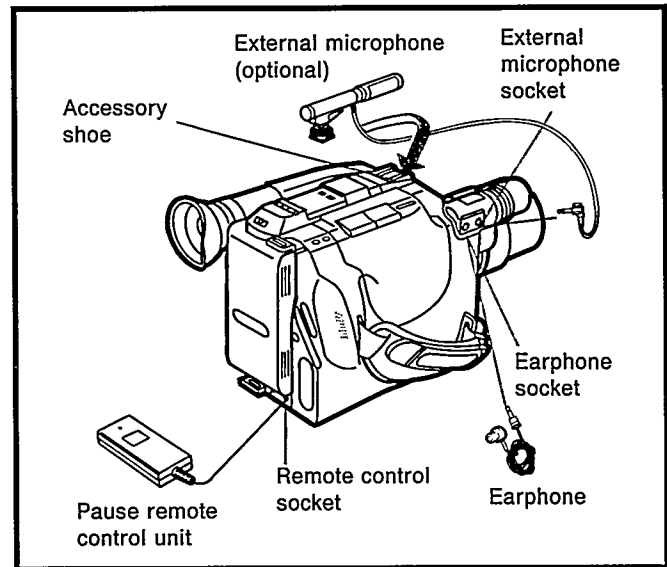

In case of difficulty

Symptoms	Check points
Power source	
— The power does not turn on.	<ul style="list-style-type: none"> ● Is the power supply unit correctly connected to the Camcorder?
— The power turns on, but it turns off again immediately.	<ul style="list-style-type: none"> ● If the battery pack is exhausted, replace it with a fully charged one. ● If condensation has formed, wait until it has dissolved.
Camera recording	
— The power is on, but no picture appears in the EVF.	<ul style="list-style-type: none"> ● Is the lens covered with the lens cap?
— Camera recording cannot be performed.	<ul style="list-style-type: none"> ● If the tab of the cassette is broken out, cover the tab hole with adhesive tape.
— The picture is not clear.	<ul style="list-style-type: none"> ● Is the eyepiece correctly adjusted to your eyesight? ● Is the lens surface dusty?
— The auto focus system does not provide optimum focus adjustment.	<ul style="list-style-type: none"> ● Is the focus mode set to AUTO focus mode? ● For shooting conditions where the AUTO focus mode cannot provide optimum focus adjustment, set to MANUAL mode and adjust the focus.
Playback	
— No playback picture is reproduced.	<ul style="list-style-type: none"> ● Is the connection to the TV set correct? ● Is the TV set turned to the video playback channel?
— The colours are not correct.	<ul style="list-style-type: none"> ● Is the colour adjustment of the TV set correct?
— The playback picture is not in colour.	<ul style="list-style-type: none"> ● Adjust the tracking. ● If the tape is old, use a new tape.

Specifications

Power source : DC 6 V
Power consumption : Recording mode 6.4 W
(Battery operation)
Video recording system : Rotary four heads, helical
scanning system
Tape speed : SP 23.39 mm/s
Tape format : VHS-C tape
Recording/playback time : 45 min. with EC-45

VIDEO

Television system : CCIR; 625 lines, 50 fields PAL
colour signal
Modulation system : Luminance; FM azimuth
recording
Colour signal; Converted
subcarrier phase shift
recording
Output level : VIDEO OUT (PHONO);
1.0 Vp-p 75 ohm unbalanced

AUDIO

Input level : MIC IN (M3); -70 dB
4.7 kohm or more unbalanced
Output level : AUDIO OUT (PHONO); -8 dB
600 ohm unbalanced
Audio track : 1 track (Normal-mono only)
Image sensor : 1/3-inch CCD image sensor
Lens : 8 : 1 Power zoom lens with
MACRO function
Auto iris
Digital artificial intelligence
auto focus system F1.4
(6 - 48 mm)
Filter diameter 43 mm
Viewfinder : 2/3-inch electronic viewfinder
Standard illumination : 1,400 lux
Minimum required
illumination : 3 lux
Video horizontal
resolution colour : VHS; More than 230 lines
Signal-to noise ratio : Video; More than 40 dB
Audio; More than 41 dB
(A-WTD)
Audio frequency
response : Normal; 80 - 8,000 Hz (SP)
Operating temperature : 0°C - 40°C
Operating humidity : 20 % - 80 %
Weight : Approx. 880 g
(without battery pack)
Dimensions : 142 (W) x 119 (H) x 263 (D) mm

AC adaptor SBC5420

Power source : AC 100 - 240 V, 50 - 60 Hz
(Automatic voltage adjustment)
Power consumption : 25 W
DC output : DC 6 V 1.8 A (Camcorder)
DC 6 V 1.3 A (Battery pack
charging)
Weight : Approx. 0.45 kg
Dimensions : 70 (W) x 58 (H) x 178 (D) mm

Weight and dimensions shown are approximate.

Specifications are subject to change without notice.





- (GB) IDENTITY CARD This card, together with the terms of guarantee (to be provided by your dealer), forms the full certificate of guarantee for this appliance
 (D) GERÄTE-KENNKARTE Diese Karte ist, zusammen mit den Garantiebestimmungen, die Ihr Händler Ihnen aushandigt, Ihr Garantieschein für dieses Gerät
 (F) CARTE D'IDENTIFICATION Associée aux conditions de garantie (qui vous sont remises par le revendeur), cette carte constitue le certificat de garantie de cet appareil
 (NL) IDENTIFICATIEKAART Deze kaart vormt, samen met de garantievoorwaarden (welke door uw dealer verstrekt worden), het garantiebewijs voor dit apparaat
 (I) CARTE D'IDENTIFICAZIONE Questa cartolina rappresenta insieme alle condizioni di garanzia (da consegnare dal vostro rivenditore) il documento di garanzia per questo apparecchio
 (E) TARJETA DE IDENTIFICACIÓN La garantía de este aparato se compone de esta tarjeta y de las condiciones de garantía que le entregará su concesionario
 (P) CARTÃO DE IDENTIFICACÃO Este cartão, em conjunto com as condições de garantia em vigor (explicadas pelo seu vendedor) constituem o certificado de garantia do seu aparelho
 (GR) ΔΕΛΤΙΟ ΤΑΥΤΟΤΗΤΑΣ Η καρτέλλα αυτή μαζί με τους όρους εγγυήσεως (που θα προμηθευθείτε από το κατάστημα που αγοράσατε την συσκευή), αποτελούν το πλήρες πιστοποιητικό εγγυήσεως της συσκευής σας.

PHILIPS

