

*Owner's Manual*

# ***Stingray II***



For Sony TRV30, TRV730, TRV530, TRV330 and TRV120 Camcorders



[www.uwimaging.com](http://www.uwimaging.com)

## Welcome

---

Congratulations on your purchase of a Stingray II video housing.

Please inspect the packaging of your product to verify that there was no damage during shipping.

If you are not familiar with your camcorder's features, please take time to become familiar with the camcorder before you proceed in this manual. This manual assumes you have a working knowledge of your camcorder and will only cover operational procedures relative to the underwater housing.

The term "Push" when referenced in this manual means to press and release in one motion. If a function requires a button to be continually held, the manual will read, "press and hold".

Periodically refer to the website for instruction revisions.  
<http://www.uwimaging.com>

## Caution - Caution - Caution

We hope you have a wonderful underwater experience with Light & Motion equipment. To increase your enjoyment and the life span of your new gear please take an extra minute to review common errors which will result in equipment damage or destruction.

- Check the operation of all your equipment several weeks prior to your trip. If maintenance or repair is necessary, then time is available for both shipping and repair scheduling.
- Never transport or ship the housing with the camcorder inside. This may damage your camcorder.
- Never leave your housing in the rinse bucket, it may be damaged by other equipment.
- When removing the camcorder from the housing after a dive, do so in a dry controlled environment away from other SCUBA related equipment. This prevents water from other equipment or water from another diver accidentally entering the housing.
- If a product is flooded, immediately rinse it with fresh water. Most non-electrical parts will be salvageable if not corroded by salt water

---

Look for these symbols to help identify special information.



Hot Tip



Important



Caution

## Table of Contents

---

Getting Started .....	4
Camera Preparation .....	5
Mounting the Camera .....	5
Operation of the Stingray II .....	6
Optic Installation and Removal .....	8
Monitor Back ID and Operation .....	8
Pre-Dive Checklist .....	9
First Time Use .....	9
After Diving Care .....	9
Housing Storage .....	9
O-ring Care and Maintenance .....	10
Returning Products for Care .....	11
Contact Light and Motion .....	11

## Getting Started

Illustrated below are the locations of Stingray's features, ports, and functions. Take time to familiarize yourself with the housing.

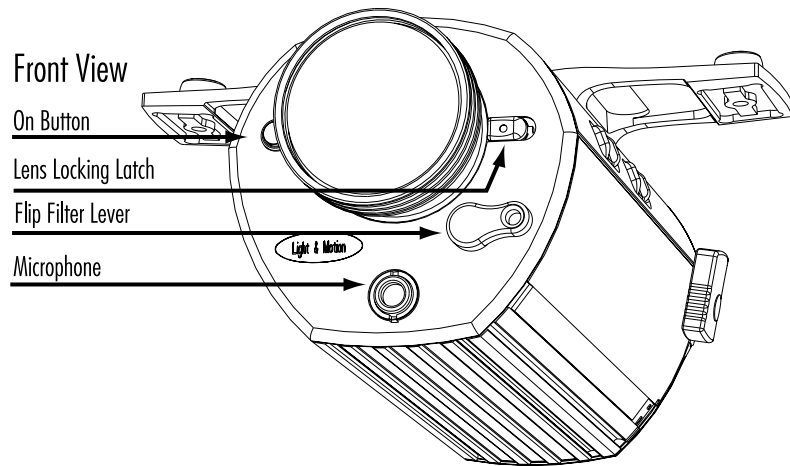

## Rear View

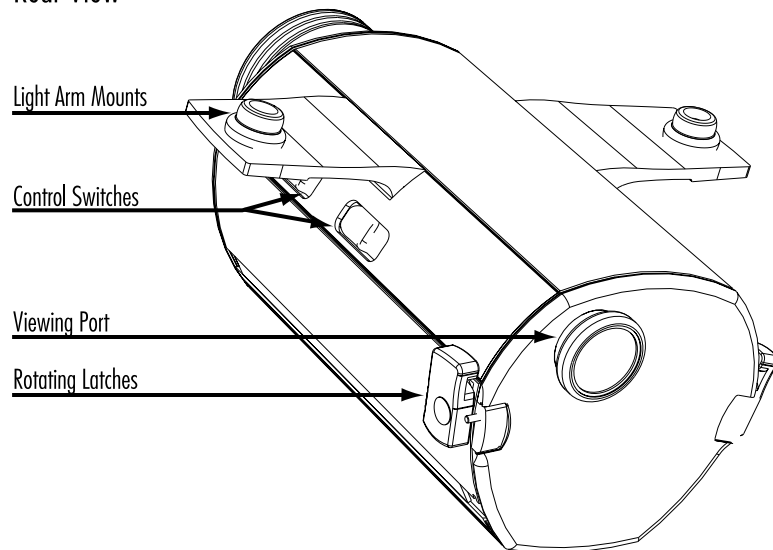

## Camera Preparation

- 1) Install the appropriate fully charged Sony camcorder battery.
- 2) Install a Sony MiniDV tape or Digital8 tape into your camcorder.
- 3) Install a Memory Stick in your camcorder

## Mounting the Camera

1. Remove the rear plate by simultaneously rotating both latches down and rearward of the housing body.
2. Remove the Camera Tray.
  - A. Push forward on the Camera Tray.
  - B. Press the Camera tray Release Button down.Camera Tray is spring loaded and will slide out of housing.
3. Position the Camera Tray underneath the camera, oriented with the multi-colored power cable to the rear of the camcorder.
4. Secure the camcorder to the Camera Tray by tightening the Camera Tray Mounting Screw into the tripod mount of the camcorder.
5. Remove the camcorder's DC in cover, LANC cover and Video Jacks cover.
6. Insert the larger front cable into the camcorder's red MIC jack.
7. Insert the rear black cable into the camcorder's yellow AUDIO/VIDEO jack.
8. Insert the rear multi-colored cable into the camcorder's HOT SHOE mount. Check the seat of the cable in the HOT SHOE mount and insure that it is all the way forward and completely seated.
9. TRV30, 330 and 530 only: Extend the Viewfinder backward until it locks at its furthest extension.
10. Align front of Camera Tray with base of housing and partially slide into housing.
11. Before sliding all the way into the housing, insert cable (from housing) into the camcorder's blue LANC jack.



(Fig. 6 TRV330, TRV530 and TRV730)

12. Slide Camera Tray forward until Release Button engages.
13. Rotate camcorder power switch to Memory.



Although camcorder Power switch is set to Memory, when camcorder initially interfaces with Stingray, it will be in Camera mode.

14. Replace rear plate.
  - A. Perform an o-ring inspection.
  - B. Align guide pins into base of Camera Tray.
  - C. Rotate both latches evenly until they lock. Ensure rear plate draws in straight and that o-rings seat evenly.

## Operation

---

The Stingray housing is designed to access basic camcorder features using electromagnetic switch control sets (left and right side of Stingray) and mechanical interfaces (front plate).

### Right Control Set Controls

---

#### ZOOM Switch

**T** - Slide forward and hold for telephoto (subjects appear closer).

**W** - Slide rearward and hold for wide angle (increases viewing angle).

MODE/OFF - REC/PHOTO

#### **MODE/OFF**

Slide switch backward and release to toggle between Camera and Memory modes.

Slide switch backward and hold for three seconds to turn camcorder off.

#### **REC/PHOTO**

In Camera mode, slide switch forward and release to toggle between record and stand-by modes.

In Memory mode, slide switch forward and release to capture an image to Memory Stick.

### Left Control Set

---

#### FOCUS Switch

**N** - Slide switch forward and hold to put camcorder into manual focus and move focus point closer to camcorder.

**F** - Slide switch backward and hold to put camcorder into manual focus and move focus point further from camcorder.

#### MOM. AF / AF LOCK Switch

**MOM. AF** - Slide switch forward and hold to put camcorder into "momentary auto focus". Camcorder remains in auto focus as long as the switch is held forward. Once released, the camcorder switches to manual focus. This is useful in stopping the camcorder from "seeking" when filming in a low contrast environment. To return the camcorder to auto focus, slide MOM. AF / AF LOCK switch backward to the AF LOCK position and release.

**AF LOCK** - Slide switch reward to return camcorder to auto focus from manual focus.

### Front Plate

---

- 1) Microphone - Records sound to a depth of 80ft.
- 2) Flip filter - Rotate lever to engage or disengage color correction filter.
- 3) ON Button - Camcorder will be on and in Camera mode when properly installed into the housing. Press the ON button once to turn the camcorder on after camcorder has been turned off by the MODE/OFF switch, or if camcorder has automatically shut down.

## Front Optic Installation / Removal

---

### To Remove Optic

---

1. Slide LOCKING PIN away from optic.
2. Rotate optic counter clockwise.
3. Pull away from housing.

### To Install Optic

---

1. Perform an o-ring inspection.
2. Align optic to housing details.
3. Press optic into housing.
4. Rotate clockwise until LOCKING PIN engages.

## Monitor Back ID and Operation

---

Monitor Back installs into the Stingray in the same manner as the Rear Plate.

### Monitor Back Identification

---

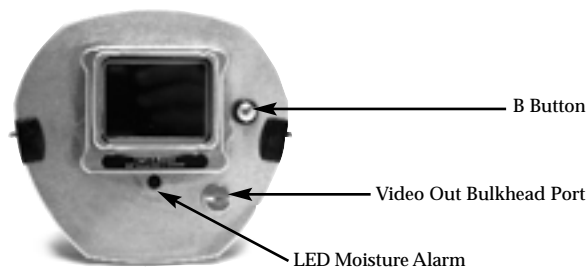

### Monitor Back Operation

---

**B** - Adjusts the brightness of the Monitor Back LCD, adjustment will not affect the recorded image.

**VIDEO OUT BULKHEAD PORT** - Allows the addition of a video out cable for surface viewing while Stingray is underwater.

**LCD MOISTURE ALARM** - Audio and visual alarms will signal if moisture is detected inside the housing. Alarm performs a three second diagnostic check when initially receiving power.



When camcorder transitions from Memory to Camera modes there is a 2-3 seconds pause while the camcorder keys the tape. Monitor Back will black out during this time and LED alarm will sound when Monitor Back is re-powered.

## Pre-Dive Checklist

---

- 1) Install a Mini DV / Digital 8 tape and Memory Stick in the camcorder.
- 2) Install a completely charged battery in the camcorder.
- 3) Verify operation of all housing controls.
- 4) Check that the front bayonet port is securely engaged and that the latch pin is in the locked position. Clean lens if necessary.
- 5) Check that the rear plate o-rings are seated correctly and that the rear latches are in the closed and locked position.

## First Time Use

---



All Light and Motion housings are pressure tested prior to shipping. However, there could be unseen damage due to shipping. A test dive without the camcorder in the housing is recommended.

After the initial dive with just the housing, make the following checks.

1. Dry off housing exterior.
2. Remove the Rear Plate and visually inspect for moisture.
3. Reach inside the housing and trace a finger around all view ports and mating surfaces.
4. If any water is detected, contact the housing reseller or the Light & Motion service department.

## After Diving Care

---

1. Immediately submerge the housing in fresh water. While in fresh water, work all the switches and press all the buttons, to work any remaining salt water out of the housing buttons.
2. Remove housing from rinse tank and then simply towel dry.

## Housing Storage

---

Store housing and Travel Case in a dry location the first 24 hours after a dive. Leave the Rear Plate off the housing to allow for air circulation. Similarly, leave Travel Case Lid about two inches open. Allow any residual water to evaporate from the Travel Case prior to storing the housing.

## O-ring Care & Maintenance

---

O-rings are the critical component that keeps water out of the housing. Routinely inspect o-rings and replace at least once a year. If your o-rings are damaged, contact the Light & Motion service department for an o-ring replacement kit.

Follow these steps for proper o-ring function.

- 1) The sealing system used on the rear plate incorporates two o-rings. This is the most critical area of the housing for maintenance and should be inspected before every dive.
- 2) Make sure the rear plate o-rings and the mating surface on the inside of the main housing are clean from grit, hair, lint and anything that could potentially breach the o-ring seal.
- 3) After frequent diving or if o-rings appear dirty, remove o-rings and clean the grooves. To remove o-rings, use finger pressure or the rounded edge of a plastic card to lift the o-ring out of the groove.
  - ✔ Never use a metal object to remove an o-ring. It will cause damage to the o-ring and mating surface.
- 4) To check o-rings for damage, place the o-ring between the index finger and thumb. Then pull the o-ring through your fingers, feeling for any debris or wear.
- 5) If o-rings are dirty, it is best to replace them. Washing dirty o-rings with soap and water is not recommended. Soap breaks down the lubricants and will compromise the integrity of the seal.
- 6) Properly greased o-rings will help maintain sealing integrity and minimize o-ring degradation. Use enough grease to lubricate the o-ring thoroughly, but not so much that it will attract additional debris.
- 7) Clean the groove with a lint free swab or the folded edge of a paper towel.
- 8) All of the front optic ports for the housing also utilize two o-ring seals. Also check these seals every time the optic is removed.

Stingray o-ring Replacement Kit part # 802-0134 includes:

Two o-rings for the Rear Plate or Monitor Back and two o-rings for front optic.

Rear Plate o-rings

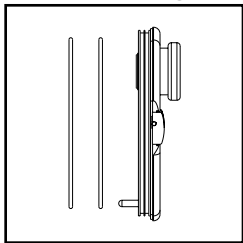

Monitor Back o-rings

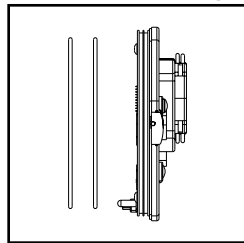

Optic o-rings

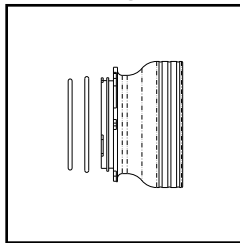

## Returning Products for Care

---

✔ We highly recommend a factory annual service to maintain proper operation of your Stingray II Housing

- 1) Before returning your Light & Motion product for care, please call or email our service department for a RMA number.
- 2) Ship your product pre-paid freight with the return number printed on the outside of the box. It is recommended that you keep your shipper's tracking number until the product is returned to you.

✔ Warning: Do not ship your camera inside the housing. Shipping companies may drop your system from up to three feet which could damage your camera.

## Contact Light and Motion

---

Sales Department:

831-645-1525 • Fax 831-375-2517  
sales@lmindustries.com

Service Department

831-645-1572 • Fax 831-375-2517  
support@lmindustries.com

Mail:

Light & Motion  
300 Cannery Row  
Monterey, CA 93940

World Wide Web:

[www.uwimaging.com](http://www.uwimaging.com)

European Service Center:

Attn: Steve Mawle  
The New House Jubilee Lane  
Milton under Wynchwood  
Chipping Norton OX7 6EP England  
441993832396 (ph.)  
441993832707 (fax)  
FisheyeUK@aol.com



300 Cannery Row • Monterey, CA 93940  
(831) 645-1525 • Fax (831) 375-2517  
[www.uwimaging.com](http://www.uwimaging.com)