

Fisher-Price®

H9998

## Mix & Match Musical Mobile



Please keep this instruction sheet for future reference,  
as it contains important information.

Adult assembly is required.

Requires four "C" (LR14) **alkaline** batteries for operation (not included).

Tool required for assembly: Phillips screwdriver (not included).



[www.fisher-price.com](http://www.fisher-price.com)

## Parts



Arm



3 Discs



Dome



3 Soft Toys



Clamp



Frame



Crib Adapter



Base

Note: Tighten and loosen all screws with a Phillips screwdriver. Do not overtighten.

### **WARNING**

- Possible entanglement injury. Keep out of baby's reach.
- Remove mobile portion from crib or playpen when baby begins to push up on hands and knees.

### **CAUTION**

This toy contains small parts in its unassembled state.  
Adult assembly is required.

- A crib mobile is intended for visual stimulation and is not to be grasped by a child.
- Remove mobile portion from crib or playpen when baby begins to push up on hands and knees.
- Always attach with all provided fasteners (clamp) tightly to a crib or playpen according to the instructions. Check frequently.
- Do not add additional strings or straps to attach to a crib or playpen.

## Battery Installation

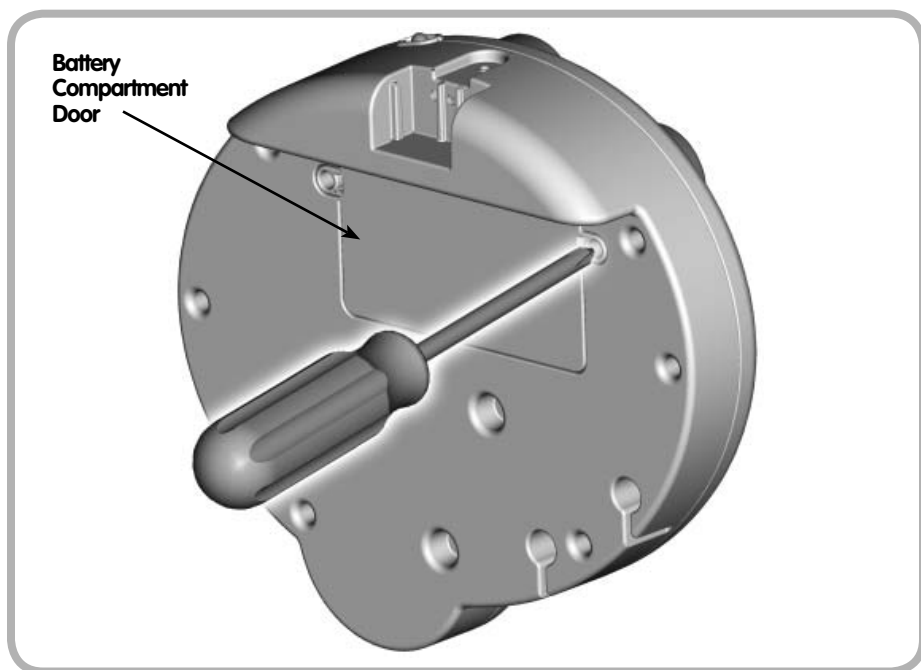

- Locate the battery compartment door on the back of the base.
- Loosen the screws in the battery compartment door and remove the battery compartment door
- Insert four "C" (LR14) **alkaline** batteries.

**Hint:** We recommend using **alkaline** batteries for longer life.

- Replace the battery compartment door and tighten the screws .
- When sounds or light become faint or movement of the mobile is sluggish, it's time for an adult to change the batteries!



- Protect the environment by not disposing of this product with household waste (2002/96/EC). Check your local authority for recycling advice and facilities (Europe only).

## Battery Safety Information

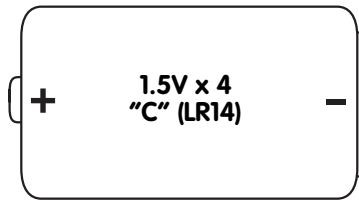

**Shown Actual Size**

In exceptional circumstances, batteries may leak fluids that can cause a chemical burn injury or ruin your product. To avoid battery leakage:

- Do not mix old and new batteries or batteries of different types: alkaline, standard (carbon-zinc) or rechargeable (nickel-cadmium).
- Insert batteries as indicated inside the battery compartment.
- Remove batteries during long periods of non-use. Always remove exhausted batteries from the product. Dispose of batteries safely. Do not dispose of the product in a fire. The batteries inside may explode or leak.
- Never short-circuit the battery terminals.
- Use only batteries of the same or equivalent type, as recommended.
- Do not charge non-rechargeable batteries.
- Remove rechargeable batteries from the product before charging.
- If removable, rechargeable batteries are used, they are only to be charged under adult supervision.

# Assembly

1

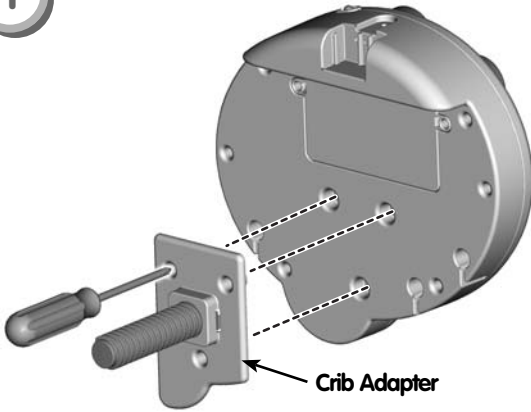

- Fit the crib adapter to the base.
- Tighten the three screws in the crib adapter.

2

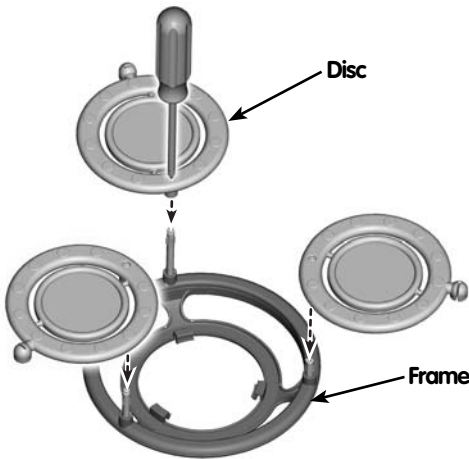

- Fit the peg on a disc onto one of the posts on the frame, as shown.
- Tighten the screw in the disc.
- Repeat this procedure to attach the other two discs to the frame.

## Assembly

3

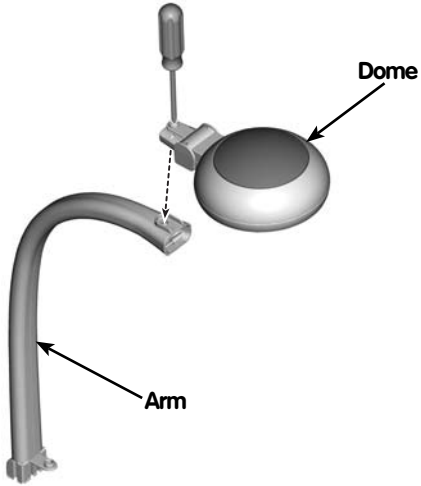

- Fit the dome into the end of the arm.
- Tighten the screw in the dome.

4

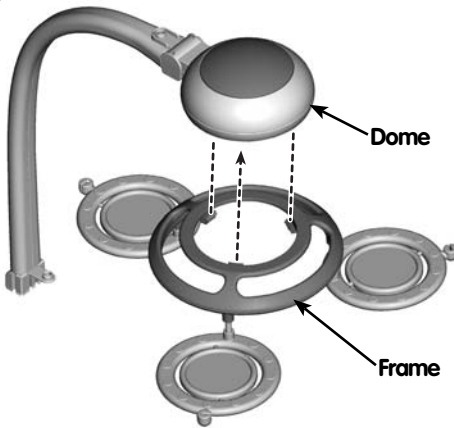

- **"Snap"** the frame to the underside of the dome, as shown.

## Assembly

5

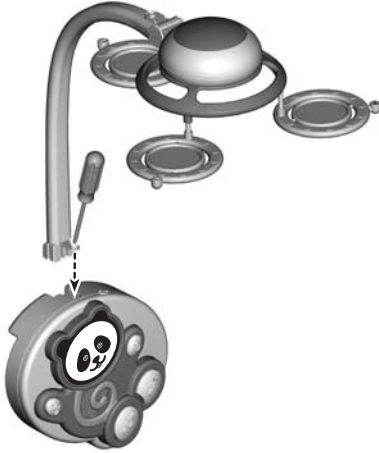

- Slide the arm into the opening in top of the base.
- Tighten the screw in the arm.

6

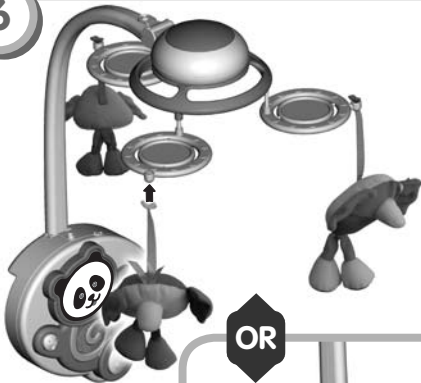

You can attach the soft toys to either the mobile (over baby's head) or to the base (inside the crib).

### ← **Mobile Attachment**

- Fit a soft toy strap up through a slot in a disc. Pull down on the strap so that the end forms a "T" on top of the disc.
- Repeat this procedure to attach the other two soft toys to the remaining discs.

OR

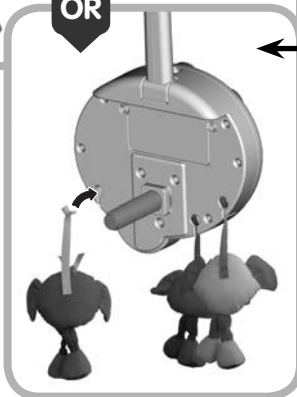

### ← **Base Attachment**

- Fit the "T" on the end of each soft toy strap into the three slots on the back of the base, as shown.

## Crib Attachment

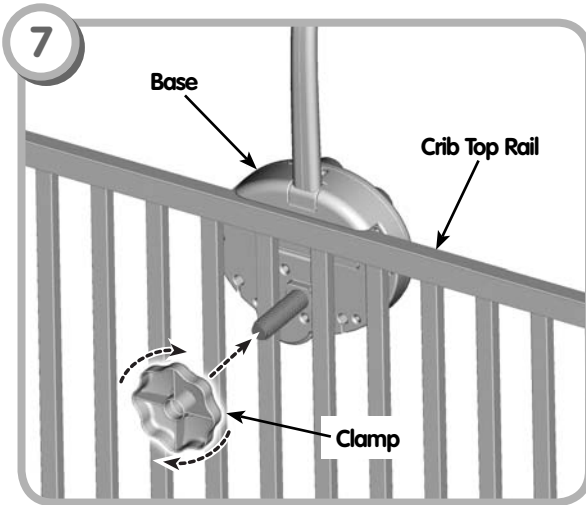

- Fit the base on the crib top rail, so that the threaded peg extends outside the crib.
- Fit the clamp onto the threaded peg and turn the clamp clockwise to secure the base to the crib rail. Do not over-tighten the clamp.

### **WARNING**

To prevent entrapment of baby's head, keep distance between the bottom of the product and the crib mattress to at least 7 inches.

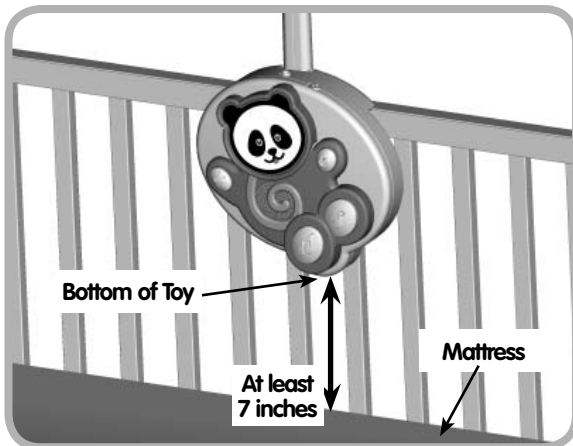

- If the distance between the toy and the mattress is less than 7 inches, lower the crib mattress.





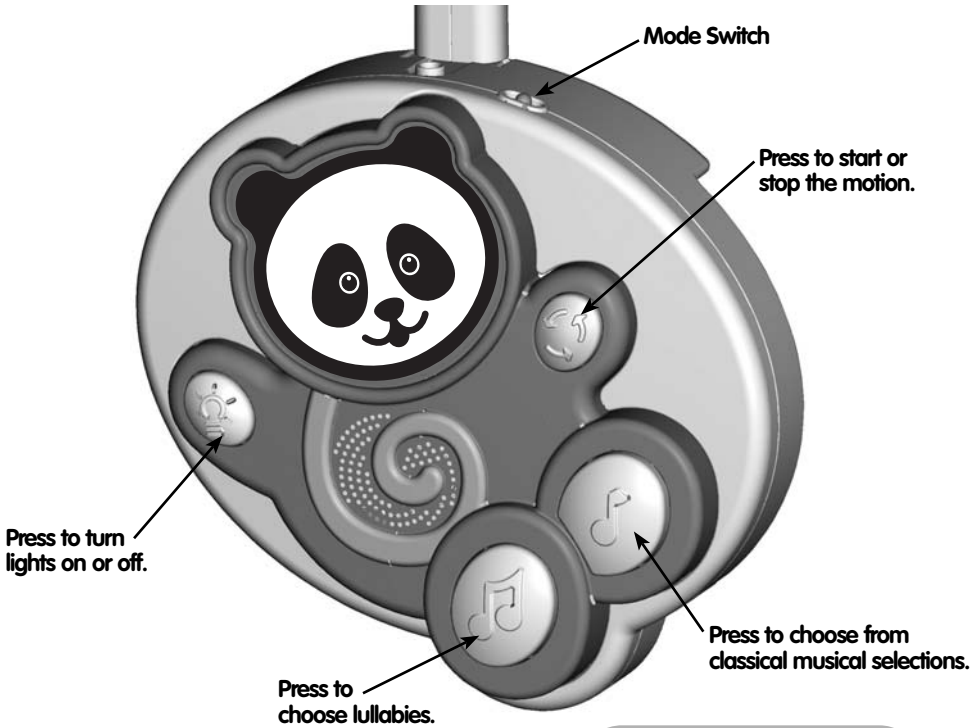

## Lights, Sounds and Gentle Motions

Enjoy projected lights on baby's ceiling, soft music and gentle motions.



Locate the mode switch on the top of the base. Slide the switch to one of the following positions:

-  Enjoy about 10 minutes of soft lights, motions and music at higher volume.
-  Choose this position for lights, motions and music with lower volume.
-  Set to this position for lights and motions without music.
-  Slide the switch to this position to turn off.

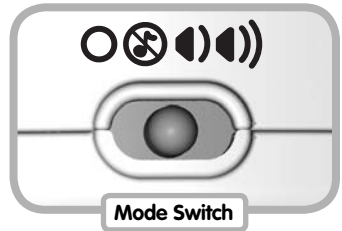

## Change to a Crib Side Music Box

When baby outgrows the mobile, follow these steps to convert to a music box with ceiling projection.

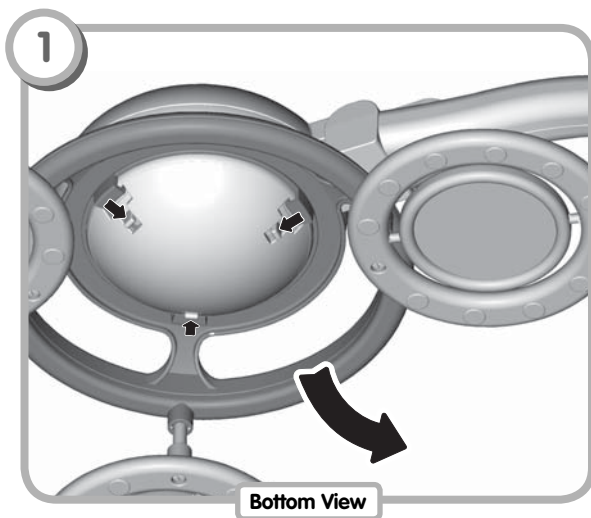

- Slide the latches on the underside of the dome and pull to remove the frame. Set the frame aside.

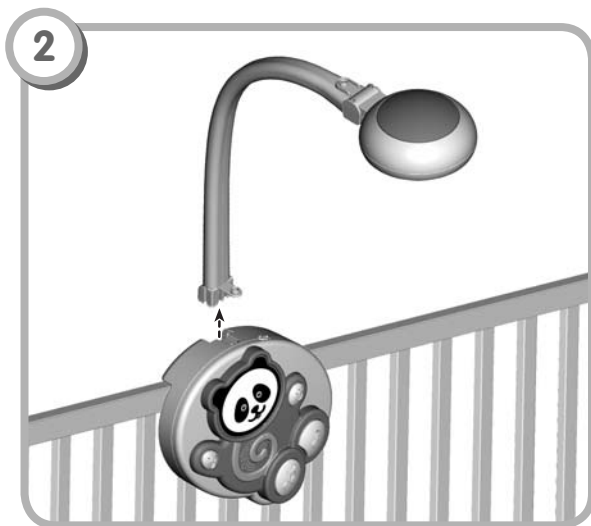

- Loosen the screw in the arm and remove the arm from the base.

## Change to a Crib Side Music Box

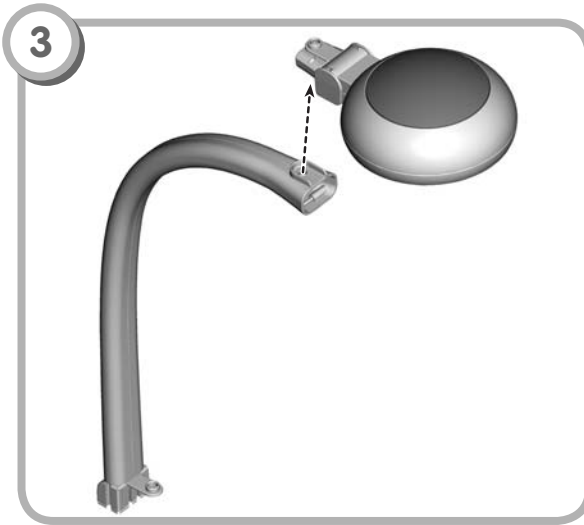

- Loosen the screw in the dome and remove the dome from the arm. Set the arm aside.

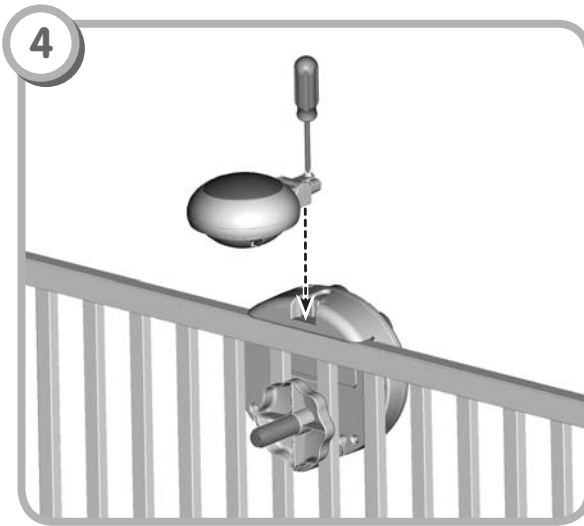

- Slide the dome into the slot in the top of the base so that the dome faces away from the crib.
- Tighten the screw in the dome. Store the arm and frame in a safe place.

## Care

### Soft Toys

- Place the soft toys in a pillowcase and wash them in cold water on gentle cycle. Tumble dry on low heat. Do not use bleach.

### Mobile Base, Arm and Dome

- Wipe the toy with a clean cloth dampened with a mild soap and water solution. Do not immerse the toy.

## FCC Statement (United States Only)

This equipment has been tested and found to comply with the limits for a Class B digital device, pursuant to part 15 of the FCC rules. These limits are designed to provide reasonable protection against harmful interference in a residential installation. This equipment generates, uses and can radiate radio frequency energy and, if not installed and used in accordance with the instructions, may cause harmful interference to radio communications. However, there is no guarantee that interference will not occur in a particular installation. If this equipment does cause harmful interference to radio or television reception, which can be determined by turning the equipment off and on, the user is encouraged to try to correct the interference by one or more of the following measures:

- Reorient or relocate the receiving antenna.
- Increase the separation between the equipment and receiver.
- Consult the dealer or an experienced radio/TV technician for help.

Note: Changes or modifications not expressly approved by the manufacturer responsible for compliance could void the user's authority to operate the equipment.

## Consumer Information

Visit us on-line at [www.service.fisher-price.com](http://www.service.fisher-price.com).

Call Fisher-Price® Consumer Relations, toll-free at **1-800-432-5437**, 9 AM- 7 PM EST Monday through Friday and 11 AM - 5 PM EST Saturdays. Hearing-impaired consumers using TTY/TDD equipment, please call 1-800-382-7470.

Write to us at: Fisher-Price® Consumer Relations  
636 Girard Avenue, East Aurora, New York 14052

For countries outside the United States:

**CANADA - Questions? 1-800-567-7724**, Mattel Canada Inc., 6155 Freemont Blvd., Mississauga, Ontario L5R 3W2; [www.service.mattel.com](http://www.service.mattel.com).

**GREAT BRITAIN - Mattel UK Ltd**, Vanwall Business Park, Maidenhead SL6 4UB. Helpline: 01628 500303; [www.service.mattel.com/uk](http://www.service.mattel.com/uk).

**AUSTRALIA - Mattel Australia Pty. Ltd.**, 658 Church Street, Locked Bag #870, Richmond, Victoria 3121 Australia. Consumer Advisory Service 1300 135 312.

**NEW ZEALAND - 16-18 William Pickering Drive**, Albany 1331, Auckland.

**ASIA - Mattel East Asia Ltd**, Room 1106, South Tower, World Finance Centre, Harbour City, Tsimshatsui, HK, China.

Fisher-Price, Inc., a subsidiary of Mattel, Inc., East Aurora, New York 14052 U.S.A.  
©2006 Mattel, Inc. All Rights Reserved. ® and ™ designate U.S. trademarks of Mattel, Inc.