

signa® 6 plus whirlpool bath

the signa® whirlpool bath takes its name from the medieval central italian walled city, lastra a signa.



Like the walled city for which it is named, Signa® 6 was specially developed and designed for walled surround spaces.

whirlpool bath features:

- 4 fully adjustable TheraPro™ jets
- 4 directionally adjustable AccuPro™ jets
- RapidHeat™ in-line heater
- Electronic on/off control with temperature readout
- Patented Adjustable Silent Air™ Induction System
- Chromatherapy™ lighting system capable of 256 colors
- Contoured backrest
- PrO₃™ Sanitation System

signa® 6 plus whirlpool bath

model number: BP87 - RH Pump,
EP40 - LH Pump

exterior dimensions:
72" long x 42" wide x 22" high

interior dimensions (at bottom):
50" long x 24" wide

of Jets/type of Jets:
4 TheraPro™ Jets
4 AccuPro™ Back Jets

operating gallons:
55 gallons





Signa™ 6 Plus Whirlpool Bath

Model: BP87, EP40

Ordering Information

Product Code:

BP87 Signa™ 6 Whirlpool Bath
Right Hand

EP40 Signa™ 6 Whirlpool Bath
Left Hand

- Center Drain Location
- Accessories / Hardware:
 - Trip-Lever Drain Kit: #X559
 - Rotary Trip-Lever Drain Kit: #K606
 - TheraPro™ Jet Rnigs Kit: #D095
 - AccuPro™ Jet Rings Kit (2Req'd): #P556
- Trim Kit Finishes Available:
 - (827) - Chrome
 - (898) - Brushed Chrome
 - (815) - Satin Nickel
 - (829) - Bright Brass
 - (805) - Platinum
 - (826) - Brushed Nickel
 - (845) - Oil Rubbed Bronze

Installation Notes

Refer to installation instructions included with fixture before beginning installation. Please confirm product availability and specifications before commencing with any installation work.

PRODUCT SPECIFICATIONS AND AVAILABILITY ARE SUBJECT TO CHANGE WITHOUT NOTICE.

Technical Specifications

Dimensions

72" L x 42" W x 22" H
(1829 mm) L x (1067 mm) W x (559 mm) H

Drain/Overflow

A: 16-7/8" (429 mm) B: 14" (356 mm)

Cutout

70" x 40"

Total Weight

826 lb (375 kg) / 39 lb/sq. ft. (192 kg/m²)

Operating Gallonage

55 U.S. Gal (208 Liters)
Max. 103 U.S. (390 Liters)

Product Weight

118 lb (54 kg)

Skirt Mounting

Not Available

Electrical Specifications

Requires a dedicated GFCI protected separate circuit.

Motor/Pump: 120 VAC, 15 AMP, 60 Hz.

RapidHeat™: 120 VAC, 15 AMP, 60 Hz.

Heater (Standard)

Requires a dedicated GFCI protected separate circuit.

RapidHeat™: P/N S750000

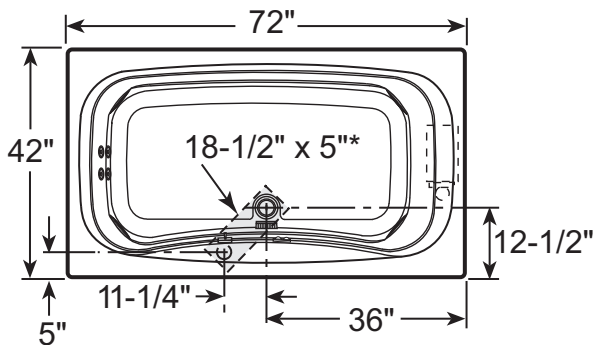

Product Shown: Signa™ 6 Plus Whirlpool Bath Right Hand Model: BP87

* Measurements inside unit represent cutout in floor to allow for drain/overflow.

Minimum Service Access dimensions given.

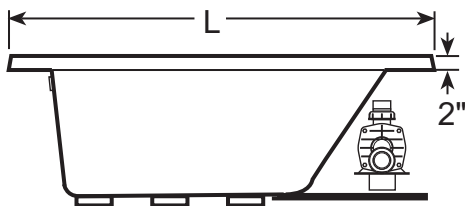

SIDE VIEW

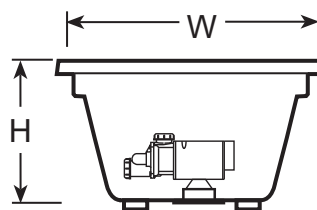

END VIEW

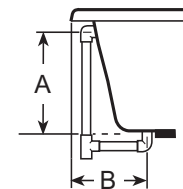

DRAIN/OVERFLOW