

## Single-Package Cooling Units

### SAFETY CONSIDERATIONS

The 50BJ, BK Single-Package Cooling Units are designed to provide safe and reliable service when operated within design specifications. However, due to system pressures, electrical components and equipment location, some aspects of installation, start-up and servicing of this equipment can be hazardous.

Only trained, qualified installers and service mechanics should install, start up and service this equipment.

When working on this equipment, observe all precautions on tags or labels attached to the unit, safety notes in the literature and any other safety precautions that apply.

- Follow all safety codes.
- Wear safety glasses and work gloves.
- Use care in handling, rigging and placing bulky equipment.

#### ⚠ DANGER

NEVER reach into unit while fan is running. LOCK OPEN AND TAG fan motor power disconnect before working on a fan. Remove the fuses and take them with you after noting this on tag.

#### ⚠ WARNING

CHECK assembly and component weights to be sure rigging equipment can handle them safely. Note also any specific rigging instructions.

WHEN STEAM CLEANING COILS, be sure area is clear of personnel.

<b>Step 4 — Rig and Place Unit with Accessories</b>	2
<b>Step 5 — Position Fan Section As Desired</b>	2
<b>Step 6 — Install Fan Motor</b>	5
<b>Step 7 — Route Fan Motor Wire</b>	6
<b>Step 8 — Align Fan Shaft and Wheel</b>	6
<b>Step 9 — Install Field-Fabricated Ductwork</b>	8
<b>Step 10 — Check Return Air Filters</b>	9
<b>Step 11 — Check Compressor Spring Mounts</b>	9
<b>Step 12 — Make Condenser Connections</b>	9
<b>Step 13 — Install Unit Drain Line</b>	11
<b>Step 14 — Make Electrical Connections</b>	12
<b>START-UP</b>	14,15
<b>General</b>	14
<b>Prior to Unit Start</b>	14
<b>Control Sequence Checkout</b>	14
<b>SERVICE</b>	15-17
<b>Fan Rotation</b>	15
<b>Indoor-Air Fan Adjustment</b>	15
<b>Lubrication</b>	16
<b>Return-Air Filters</b>	16
<b>Condensate Drains</b>	16
<b>Evaporator Coil</b>	17
<b>Water-Cooled Condenser(s)</b>	17
<b>Air-Cooled Condensers</b>	17
<b>Sight Glasses</b>	17
<b>Charging the System</b>	17
<b>Indoor-Air Fan Motor Removal</b>	17
<b>Pressure Relief Devices</b>	17
<b>Crankcase Heaters</b>	17
<b>High and Low Pressure Switches</b>	17
<b>Time Guard® Control Circuit</b>	17
<b>CONTROL SEQUENCE</b>	18

### CONTENTS

	Page
<b>SAFETY CONSIDERATIONS</b>	1
<b>INSTALLATION</b>	1-13
<b>General</b>	1
<b>Step 1 — Receive and Inspect Unit</b>	2
<b>Step 2 — Protect Unit From Damage</b>	2
<b>Step 3 — Provide Unit Support</b>	2

### INSTALLATION

**General** — The 50BJ water-cooled condenser type units and the 50BK condenserless units are single-package, vertical air conditioning units designed specifically for application with 35B Modubox and 37A Moduliner® variable volume air terminals. For air terminal installation and service refer to the separate 35B and 37A installation booklets.

Sizes 50BJ,BK016 and 024 units are shipped with all components assembled, piped and wired. Sizes 50BJ,BK028 and 034 are shipped as follows:

1. Base unit — containing evaporator coil unit, compressors and condensers (50BJ unit only).
2. Fan section.
3. Fan motor and drive.

Sizes 50BJ,BK044,054 and 064 are shipped with all components assembled, piped and wired.

### Step 1 — Receive and Inspect Unit

Check unit against shipping order. Inspect carefully for concealed shipping damage. *If shipment is damaged or incomplete, file claim with transportation company and advise Carrier Corporation immediately.*

### Step 2 — Protect Unit From Damage

To maintain warranty, protect unit against adverse weather, theft or vandalism on jobsite.

### Step 3 — Provide Unit Support

Refer to Fig. 1 — Unit Dimensions, and Table 1 — Unit Physical Data for unit size and weight. Floor unit loading should be adequate to support unit.

### Step 4 — Rig and Place Unit With Accessories

Collect all unit parts together and move them to actual installation site. Provide space around unit for service, filter access and overhead clearance as indicated in Fig. 1.

- Move and store unit in upright position. Do not remove shipping package or skids until unit is at final position. Follow rigging label instructions to prevent cabinet damage during unit positioning. **DO NOT USE CHAINS.** Raise base skid on blocks and remove bolts. Unbolt fan section from skid (028 and 034 units only).

If any 39E accessories (eg. filters) are to be used on 50BJ,BK044-064 units, refer to latest 39E Installation Instructions. The 50BJ,BK044-064 units do not contain installed filters or racks. Bolts to secure filter rack are shipped secured to base unit compressor basepan.

Units as shipped are adequately dampened against vibration. If additional dampening is desired, place sponge rubber, rubber mat or fiberglass roof insulation between floor and base of unit or install vibration isolators.

### Step 5 — Position Fan Section As Desired

UNIT SIZES 50BJ,BK016 and 024 are shipped for vertical discharge. To set up these units for top-mounted horizontal discharge, accessory filler panels must be field installed (see Fig. 1).

To set up unit sizes 50BJ,BK016 and 024 for back-mounted horizontal discharge (Fig. 1), proceed as follows:

1. Remove:
  - a. rear fan-section panel.
  - b. upper rear coil-section panel.
  - c. flexible conduit and wires from motor.
  - d. corner bolts holding fan section to coil section.
2. Remove fan section and rotate it 180° lengthwise so that motor is on left side of unit.
3. Place fan section on rear of coil section and refasten.
4. Replace motor wire and conduit.
5. Adjust the following items per Installation Step 8:
  - a. Shaft alignment.
  - b. Fan wheel position.
  - c. Pulleys.
  - d. Fan belt.
6. Replace panels as follows:
  - a. Upper rear coil-section panel on top of coil section and fasten.
  - b. Rear fan-section panel on top of fan section and fasten.

UNIT SIZES 50BJ,BK028 AND 034 are shipped in sections as noted previously. They can be field assembled for either vertical or horizontal discharge.

NOTE: Fan section panels may be removed for easier lifting and to facilitate motor installation.

To set up sizes 50BJ,BK028 and 034 units for horizontal discharge (Fig. 2), proceed as follows:

1. Remove:
  - a. Upper rear and end panels of coil section.
  - b. End panels on fan section.
  - c. Fasteners holding lower rear edge of fan panel.
2. Lift and position fan section on rear of coil section (Fig. 2). Secure with fasteners provided.
3. Install the following per Installation Step 6:
  - a. Motor mounting frame angles.
  - b. Motor on plate assembly.
  - c. Motor-plate assembly on frame angles.
  - d. Balance of drive package components.
4. Adjust the following per Installation Step 8:
  - a. Shaft alignment.
  - b. Fan wheel position.
  - c. Pulleys.
  - d. Fan belts.
5. Replace panels as follows:
  - a. Rear coil section panel on top of coil section. Rear holes will overlap fan section top panel. Fasten using hole vacated in step 1c (see Fig. 2).
  - b. All end panels.

→ Table 1 — Unit P

MODEL 50	BJ	BK	BJ	BK	BJ	BK
	016		024		028	
OPERATING WEIGHT (lbs) (Note 1)	1420	1225	1900	1470	2500	2500
OPERATING CHARGE (lbs)						
System 1	24	15	17	7	24	17
System 2	—	—	17	7	17	—
COMPRESSOR — TYPE 06						
System 1	DC337	DC537	DC724	DC824	DC337	DC537
System 2	—	—	DA724	DA824	DA724	DA537
No. of Unloading Cylinders	4	—	4	—	4	—
No. of Capacity Steps	3	—	6	—	6	—
HPS Setting (psig)	280	376	280	376	280	376
LPS Setting (psig)	27	—	27	—	27	—
CONDENSER (BJ Only)						
No. ...Type	1 SC	—	2 SC	—	2 SC	—
Max. Working Pressure (psig)	550	—	150 (Note 2)	—	550	—
Connection Size - (in.)						
Water Inlet	(1) 2 FPT	—	(1) 2 5 FPT	—	1 5+2 FPT	—
Water Outlet	(1) 2 FPT	—	(1) 2 5 FPT	—	1 5+2 FPT	—
CONDENSER (BK Only)						
Connection Size - (in.)						
Liquid	5/8 ODM	—	(2) 5/8 ODM	—	(2) 5/8 ODM	—
Discharge	1 1/8 ODM	—	(2) 7/8 ODM	—	1 1/8 ODM	—
CONDENSATE CONNECTION						
Condensate Drain	1 FPT	—	1 FPT	—	1 1/4 MPT	—
INDOOR FAN (Note 3)						
Number	2	—	2	—	2	—
Size (in.)	15 x 11	—	15 x 11	—	18 x 18	—
Nominal Cfm	6,000	—	8,000	—	10,000	—
Maximum Allowable Rpm	1200	—	1200	—	1100	—
No. of Belts...Fan Pulley PD (in.) (Note 4)	1 9 0	—	2 9 0	—	2 12 4	—
Fan Shaft Diameter - (in.)	1 3/16	—	1 3/16	—	1 1/16	—
Horsepower						
Standard...Frame Size	3 182T	—	5 184T	—	7 5 213T	—
Motor Pulley A Diameter	4 5-5 5	—	4 6-5 6	—	5 6	—
Motor Pulley B Diameter	—	—	—	—	6 5	—
Motor Efficiency (%)	79	—	84	—	84	—
Motor Shaft Diameter (in.)	1 1/8	—	1 1/8	—	1 3/8	—
Center To Center (standard and horizontal)	8 8-11 1	—	8 8-11 1	—	29 8-33 3	—
Center To Center (alternate top discharge)	—	—	—	—	—	—
Fan Speed Range (Rpm)						
Pulley A	875-1069	—	894-1089	—	925	—
Pulley B	—	—	—	—	1073	—
Alternate...Frame Size	5 184T	—	7 5 213T	—	10 215T	—
Motor Pulley A Diameter	—	—	—	—	—	—
Motor Pulley B Diameter	—	—	—	—	—	—
Fan Speed Range (Rpm)						
Pulley A	—	—	—	—	—	—
Pulley B	—	—	—	—	—	—
INDOOR COIL						
No. of Rows... Fins/in.	3 11 0	—	4 11 0	—	4 9 0	—
Total Face Area (sq ft)	16 3	—	17 4	—	21 9	—
RETURN AIR FILTERS						
No. . .Size (in.)	3 16x25x2	—	3 16x25x2	—	6 25x20x2	—
	3 20x25x2	—	3 20x25x2	—	2 16x20x2	—

**Cfm** — Cubic Feet Per Minute      **ODM** — Outside Diameter Male      **Rpm** — Revolutions Per Minute      **NO**  
**FPT** — Female Pipe Thread      **ODS** — Outside Diameter Solder      **SC** — Shell and Coil      **1**  
**Hp** — Horsepower      **PD** — Pitch Diameter      **TT** — Tube-in-Tube  
**MPT** — Male Pipe Thread      **PDR** — Pitch Diameter Range

**- Unit Physical Data**

	BK	BJ	BK	BJ	BK	BJ	BK	BJ	BK
<b>028</b>	<b>034</b>		<b>044</b>		<b>054</b>		<b>064</b>		
	2335	2610	2440	3660	3155	2888	3298	4030	3305
Refrigerant 22									
	15	24	15	30	18	45	18	40	18
	12	24	15	30	18	35	18	40	18
Serviceable Hermetic, 1750 Rpm									
	DC537 DA824	DC337 DA337	DC537 DA537	E2150 EA150	E2250 EA250	E7265 EA150	E7265 EA250	E7175 EF175	E7275 EF275
	4 6 27	4 6 27	4 6 27	2 4 27	2 4 27	4 6 27	4 6 27	4 6 27	4 6 27
	376	280	376	395	395	395	395	395	395
	2 SC 550	2 SC 550	2 SC 550	2 TT 400	2 TT 400	2 TT 400	2 TT 400	2 TT 400	2 TT 400
	5 + 2 FPT 5 + 2 FPT	(2) 2 FPT (2) 2 FPT	(2) 2 FPT (2) 2 FPT	(2) 2 1/8 ODS (1) 3/8 ODS	(2) 2 1/8 ODS (1) 3/8 ODS	(2) 2 1/8 ODS (1) 3/8 ODS	(2) 2 1/8 ODS (1) 3/8 ODS	(2) 2 1/8 ODS (1) 3/8 ODS	(2) 2 1/8 ODS (1) 3/8 ODS
Size (in ) Type									
	5/8 ODM 1/2 ODM	(2) 5/8 ODM (2) 1 1/8 ODM	(2) 5/8 ODM (2) 1 1/8 ODM	(2) 7/8 ODS (2) 1 1/8 ODS	(2) 7/8 ODS (2) 1 1/8 ODS	(2) 7/8 ODS (2) 1 1/8 ODS	(2) 7/8 ODS (2) 1 1/8 ODS	(2) 7/8 ODS (2) 1 1/8 ODS	(2) 7/8 ODS (2) 1 1/8 ODS
Size (in ) Type									
	1 1/4 MPT	1 1/4 MPT	1 1/4 MPT	1 1/2 FPT	1 1/2 FPT	1 1/2 FPT	1 1/2 FPT	1 1/2 FPT	1 1/2 FPT
Adjustable, Belt-Driven Centrifugal; 1750 Rpm Motor									
	2 18 x 18 10,000 1100 2 12 4 1 11/16	2 18 x 18 12,000 1100 2 11 0 1 11/16	2 20 x 10 16,000 1200 2 18 7 1 11/16	2 20 x 18 20,000 1200 2 18 7 1 11/16	2 20 x 18 20,000 1200 2 18 7 1 11/16	2 20 x 18 24,000 1200 2 18 7 1 11/16	2 20 x 18 24,000 1200 2 18 7 1 11/16	2 20 x 18 24,000 1200 2 18 7 1 11/16	2 20 x 18 24,000 1200 2 18 7 1 11/16
	7 5 213T 5 6 6 5 84 1 3/8	7 5 213T 5 6 6 5 84 1 3/8	15 254T 9 0 10 3 85 1 3/8	20 264T 9 8 10 9 87 1 3/8	20 264T 9 8 10 9 87 1 3/8	25 284T 9 8 10 9 89 1 3/8	25 284T 9 8 10 9 89 1 3/8	25 284T 9 8 10 9 89 1 3/8	25 284T 9 8 10 9 89 1 3/8
	29 8-33 3 —	29 8-33 3 —	17 9-21 1 18 4-22 0	17 9-21 1 18 4-22 0	17 9-21 1 18 4-22 0	17 0-20 4 17 6-21 5	17 0-20 4 17 6-21 5	17 0-20 4 17 6-21 5	17 0-20 4 17 6-21 5
	925 1073 10 215T — — — —	925 1073 10 215T — — — —	840 961 20 264T 10 9 11 8 1023 1107	840 961 20 264T 10 9 11 8 1023 1107	915 1023 25 284T 10 9 11 8 1032 1117	915 1023 25 284T 10 9 11 8 1032 1117	922 1032 30 286T 10 9 11 8 1029 1114	922 1032 30 286T 10 9 11 8 1029 1114	922 1032 30 286T 10 9 11 8 1029 1114
Copper Tubes, Aluminum Plate Fins									
	4 9 0 21 9	4 9 0 26 2	3 15 37 5	3 15 37 5	4 15 37 5	4 15 37 5	4 15 37 5	4 15 37 5	4 15 37 5
Factory Supplied — Throwaway									
	25x20x2 16x20x2	6 25x20x2 2 16x20x2	None (See Note 5)	None (See Note 5)	None (See Note 5)	None (See Note 5)	None (See Note 5)	None (See Note 5)	None (See Note 5)

**NOTES**

- Operating charge for 50BK units does not include charge for matching air-cooled condenser or refrigerant connecting piping. All 50BK units are shipped with a holding charge. Operating charge values are approximate.
- Condenser working pressure is 550 psig if factory installed, dresser adapters are removed and field-fabricated manifold is installed.

- Motors and drives other than those furnished with units 016-034 must be purchased locally. Installation may require field modification.
- Fan motor pulleys on 50BJ, BK028, 034, 044, 054, 064 are fixed pitch type. The smaller of the 2 pulleys is factory installed.
- Refer to 39E Series literature (size 39E32) for accessory information.

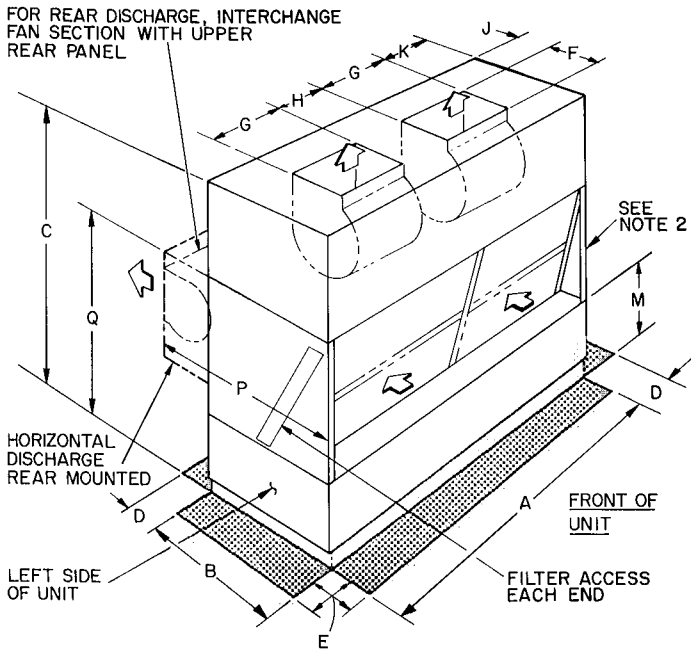

**OPTIONAL TOP HORIZONTAL DISCHARGE**

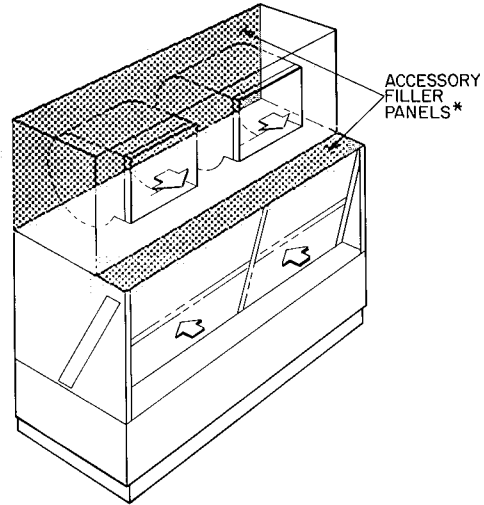

\*For optional top-mounted horizontal discharge, use accessory filler panel package as shown

**UNITS 50BJ,BK016 AND 024**

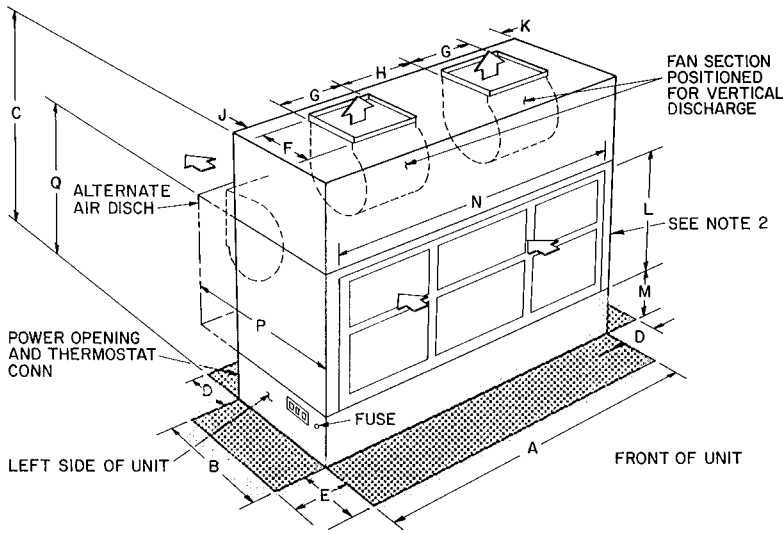

**DIMENSIONS (ft-in.)**

UNIT 50BJ,BK	016	024	028	034
A	6-8		7- 9¼	
B	2-4		2-11¼	
C	6-10½		8- 0⅞	
D	2-0		2-0	
E	3-0		3-0	
F	1- 3¾		1- 8⅞	
G	1- 2⅝		1- 8⅞	
H	1- 4¼		1- 7⅞	
UNIT 50BJ,BK	016	024	028	034
J	0-1⅞		0-2⅜	
K	2-0		1-4	
L	—		3-2¼	
M	1-8		2-1⅞	
N	—		7-4¼	
P	4- 4⅝		5-4⅞	
Q	4-11½		5-7¼	

- NOTES:**  
 1 Certified dimension drawings available on request  
 2 Water and refrigerant connections located on right side of unit.

**UNITS 50BJ,BK028 AND 034**

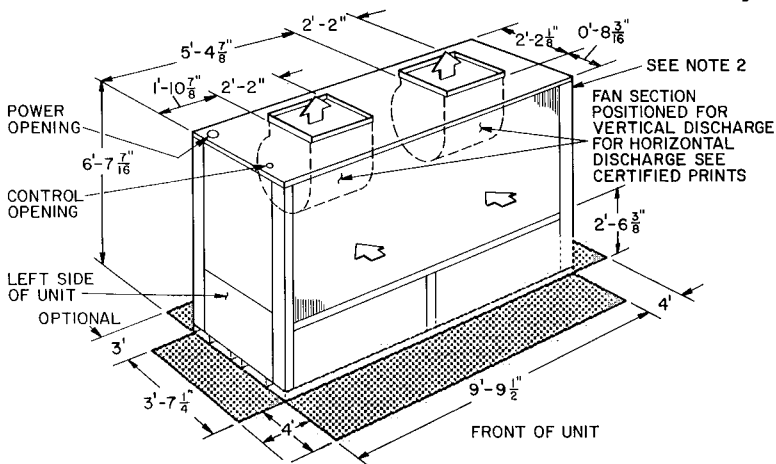

- NOTES:**  
 1 Certified dimension drawings available on request  
 2 Water and refrigerant connections for unit sizes 50BJ,BK044 thru 064 are located on right side of unit See Fig 12 for connection details  
 3 Filters are not supplied with base unit. All models are directly compatible with 39E (size 32) air handling unit components Refer to 39E literature for physical data for accessories

**UNITS 50BJ,BK004, 054, AND 064**

**Fig. 1 — Unit Dimensions**

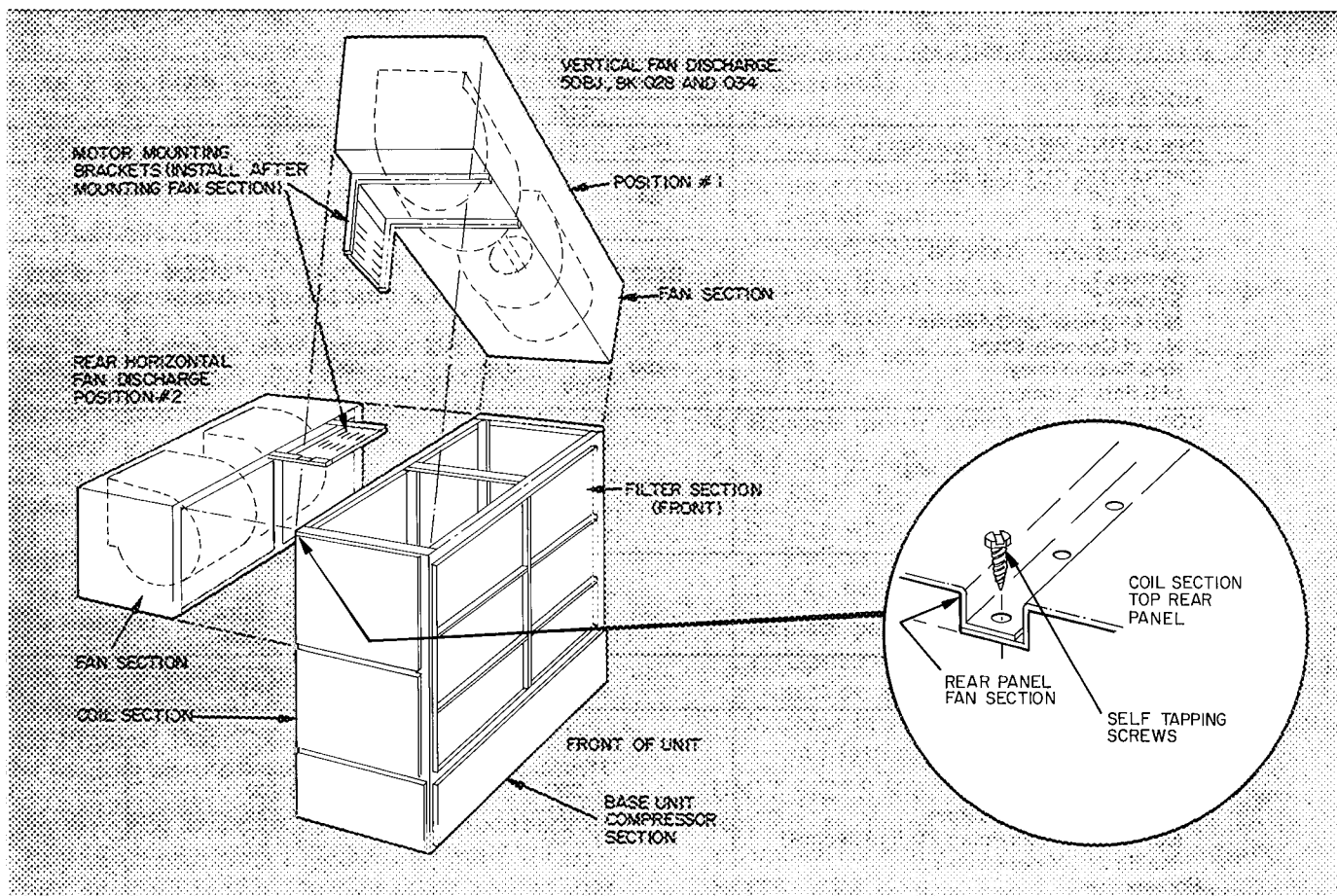

Fig. 2 — Fan Mounting (028,034 Units)

To set up sizes 50BJ, BK028 and 034 units for vertical discharge (Fig. 2):

1. Remove:
  - a. Front, rear and end panels of fan section.
  - b. Upper-rear and end panels of coil section.
  - c. Filters from coil section.
  - d. Fasteners holding filter frame top. Push out frame away from coil section frame.
2. Lift up and position fan section on coil section (Fig. 2).
3. Fasten fan-section frame to coil-section frame with fasteners provided; then reposition and refasten the filter frame moved in step 1d.
4. Install the following per Installation Step 6:
  - a. Motor mounting frame angles.
  - b. Motor on motor-plate assembly.
  - c. Motor-plate assembly on frame angles.
  - d. Balance of drive package components.
5. Adjust the following per Installation Step 8:
  - a. Fan wheel alignment.
  - b. Shaft alignment.
  - c. Pulleys.
  - d. Fan belts.
6. Replace panels as follows:
  - a. Rear coil-section panels, front and rear fan-section panels.
  - b. All end panels.

Unit sizes 50BJ, BK044, 054 and 064 are shipped with vertical discharge as standard. Other fan positions are available as a factory-installed option.

**Step 6 — Install Fan Motor.** Unit 50BJ, BK028 and 034 only. (All other units have factory-installed motors.) Install items after fan section frame has been placed in position on coil section.

NOTE: Place plywood over evaporator coil to prevent damage while installing motor and mounts.

To install motor:

1. Fasten motor mounting angle bracket to fan section. Use Fig. 2 or 3 for position reference and Fig. 4 for assembly guidance. Be sure that lips of angle brackets are around fan section frame and that slots for motor mounting plate face each other.
2. Position motor on motor plate (Fig. 5) and fasten with fasteners provided.
3. Lift motor-plate assembly and slide into motor mounting angles as shown in Fig. 4. Plate fits in angle slots. On vertical mounts, the motor mounting assembly can be lowered to bottom of motor support channels.
4. Assemble and install motor adjusting screws as shown in Fig. 6. Drive roll pins into screws to prevent the screws from backing out during motor position adjustment.

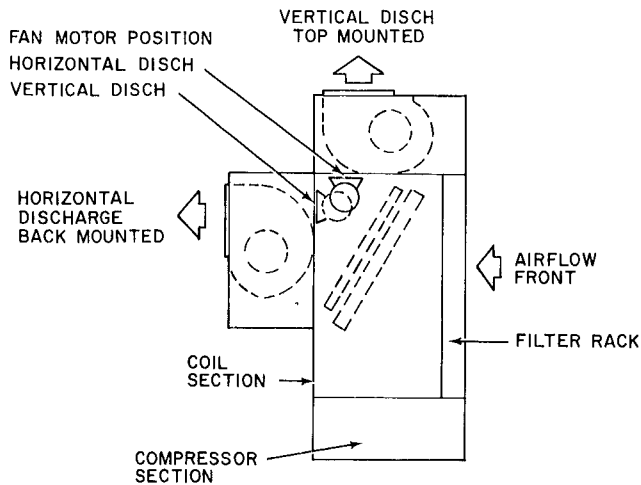

NOTE.  
 Motor pulley on left side of unit — vertical discharge  
 Motor pulley on right side of unit — horizontal discharge

**Fig. 3 — Fan and Motor Arrangements  
 50BJ, BK028, 034**

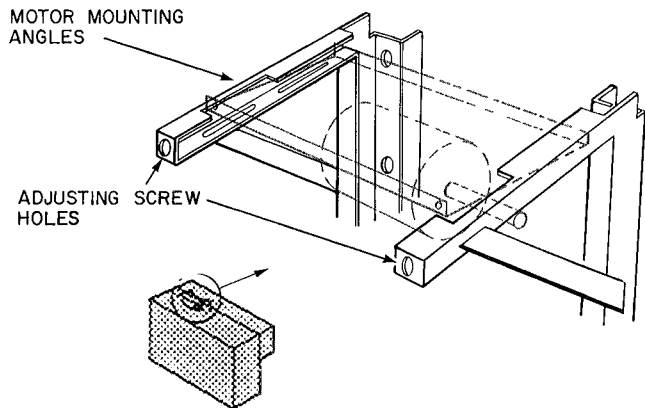

**Fig. 4 — 50BJ, BK028 and 034 Horizontal  
 Fan Motor Mounting Angles**

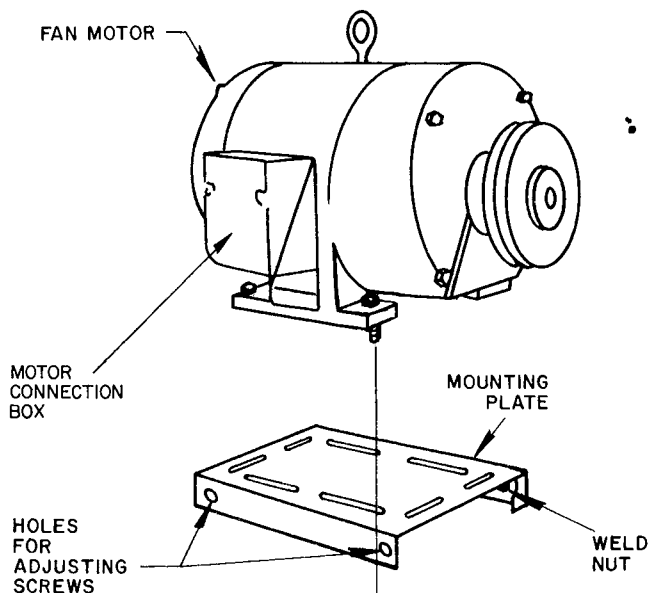

**Fig. 5 — 50BJ, BK028 and 034 Motor  
 Mounting**

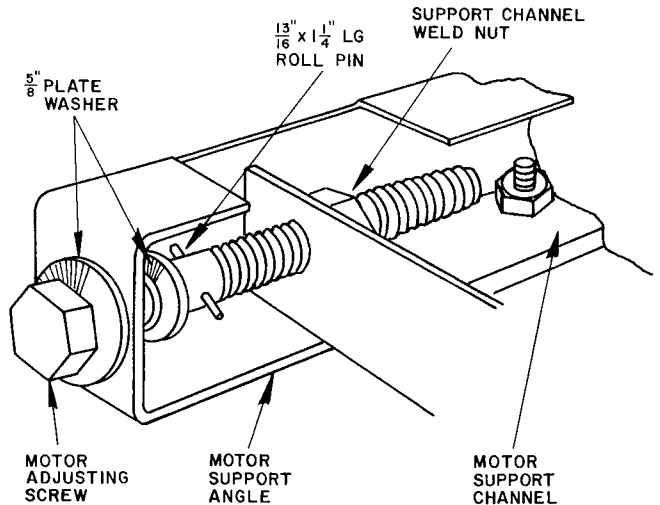

**Fig. 6 — Assembled Fan Motor  
 Adjusting Screw**

5. Adjust motor position. Fasten motor mounting plate to mounting angles.

**Step 7 — Route Fan Motor Wire (Unit 50BJ, BK 028 and 034 only)**

Fan motor must be field wired. *Proper wire routing is essential to the operation of these units. Follow wire routing instructions carefully.*

**CAUTION:** Turn off electrical power to base unit before routing wiring to fan motor.

**CHECK EQUIPMENT** — Refer to Fig. 7 and 8 for location of base unit components. Fan motor wiring is shipped coiled on top of evaporator coil. Wire tie locations are shown in Fig. 7, 8 and 9.

**ROUTE WIRING**

**CAUTION:** Route wiring with sufficient slack to permit motor adjustment. Wiring should not be pinched, touch any moving parts or sharp edges.

**VERTICAL DISCHARGE (Fig. 2. Position #1)** — Run wiring thru wire tie #1 (Fig. 9) on motor mounting bracket to the fan motor and secure. Route wiring from wire tie around motor side of mounting bracket to fan motor connection box on top of motor (Fig. 5). Cut off and discard excess wire. Refer to base unit label diagram for wiring connection details.

**HORIZONTAL DISCHARGE (Fig. 2, Position #2)** — Run wiring thru wire ties #2 and 3 (Fig. 9) to the fan motor and secure. Run wiring to connection box at back of motor (Fig. 5). Cut off and discard excess wire. Refer to unit label diagram for wiring connection details.

**Step 8 — Align Fan Shaft and Wheel**

**HORIZONTAL WHEEL CENTERING** — All wheels must be horizontally centered between the inside edges of their fan scroll venturis (Fig. 10).

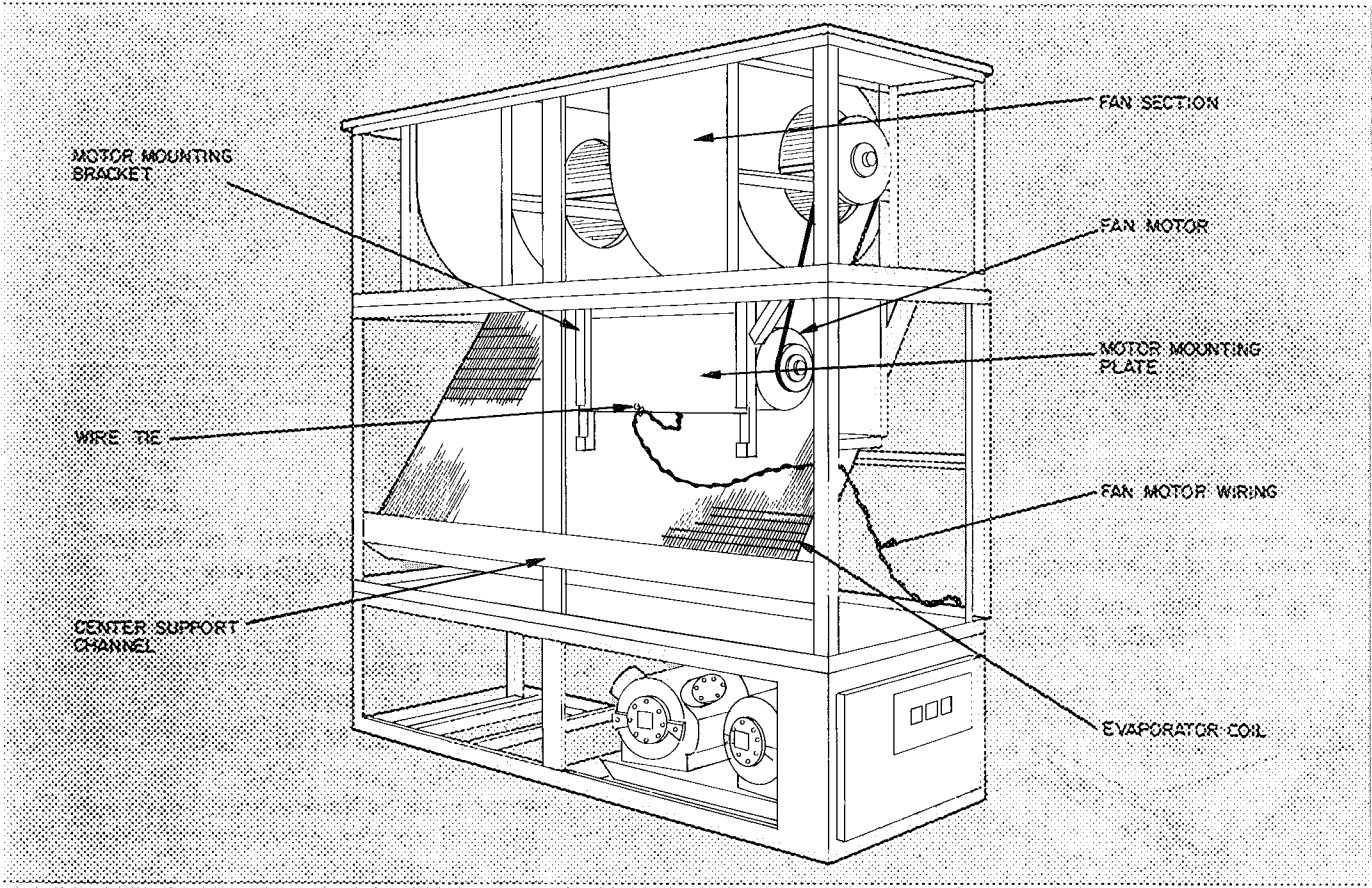

Fig. 7 — Typical 50BJ, BK028,034 Unit — Vertical Discharge

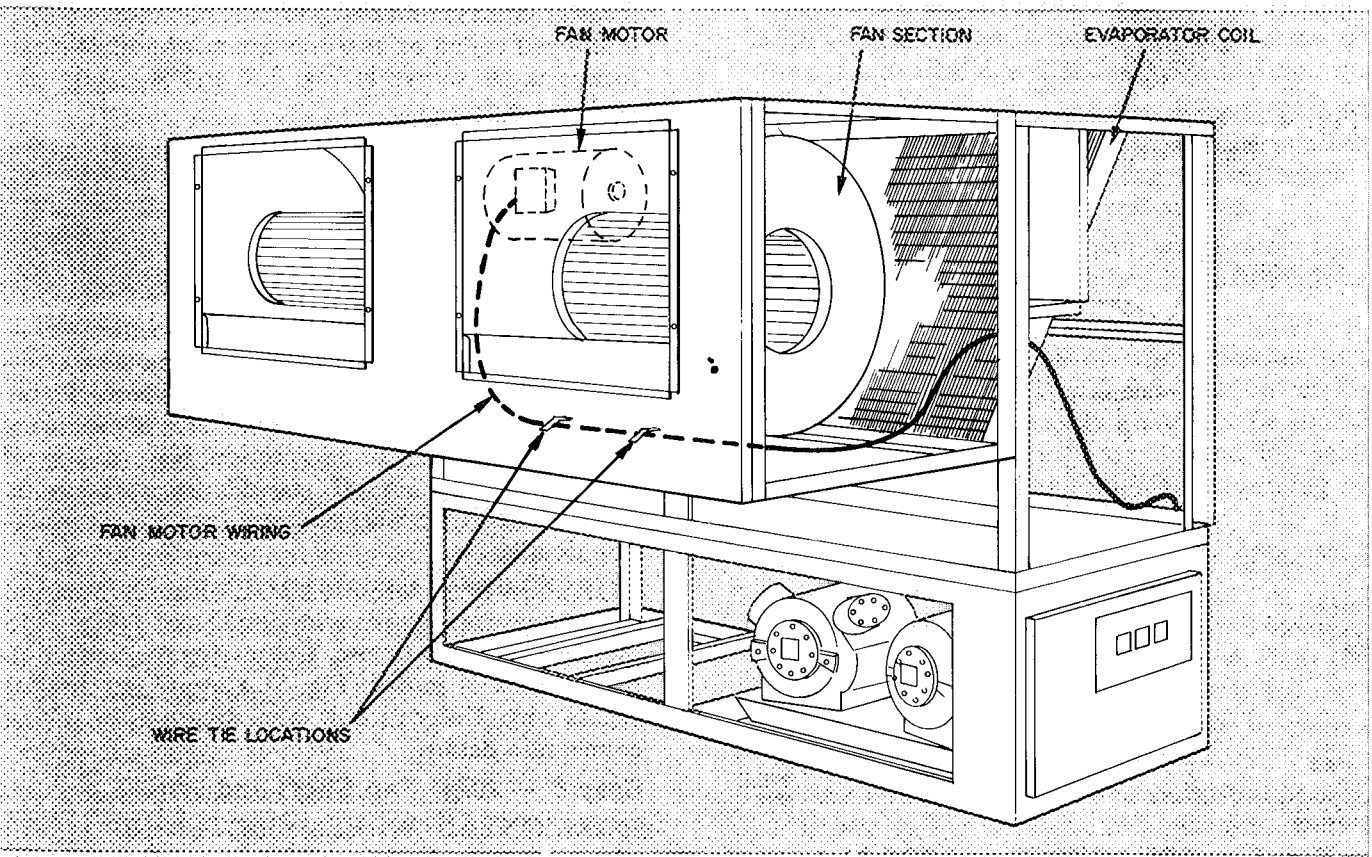
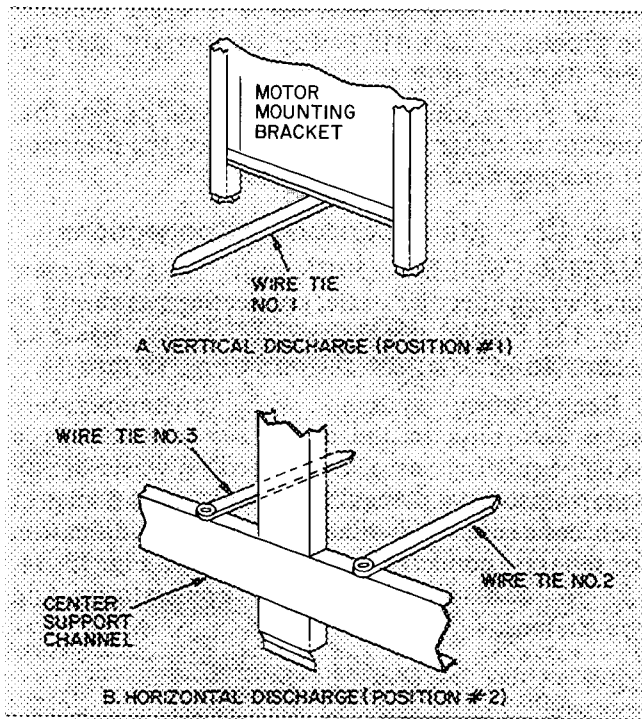
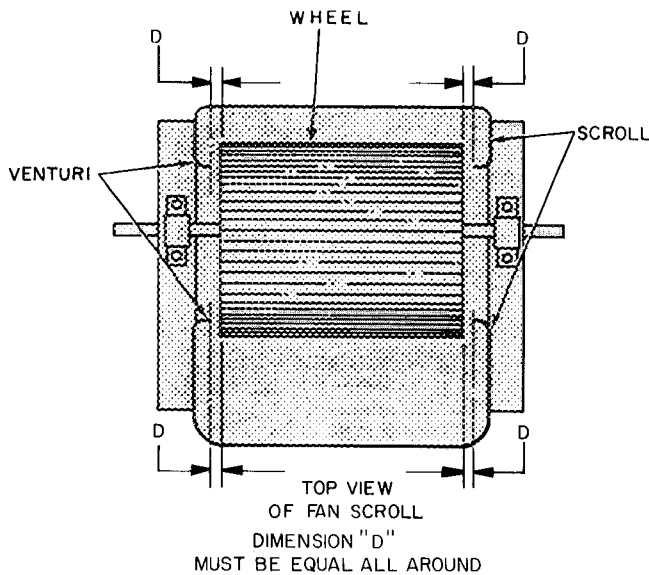

Fig. 8 — Typical 50BJ, BK028,034 Unit — Horizontal Discharge





**Fig. 9 — Wire Tie Locations**



**Fig. 10 — Horizontal Wheel Centering**

Adjust as follows:

Units 50BJ, BK016 and 024

1. Loosen setscrews holding wheel support to shaft (Fig. 11).
2. Center the wheel by sliding it horizontally (Fig. 10).
3. Retighten setscrews.

Units 50BJ, BK028,034,044,054 and 064

1. Loosen fan wheel square head setscrews on each side of fan support (Fig. 11).
2. Center wheel by sliding it horizontally (Fig. 10).
3. Retighten locking setscrews to torque specified in Table 2.

**Table 2 — Setscrew Torque Requirements**

BOLT SIZE (in.)	RECOMMENDED TORQUE (lb-ft)
5/16	15-18
3/8	22-25

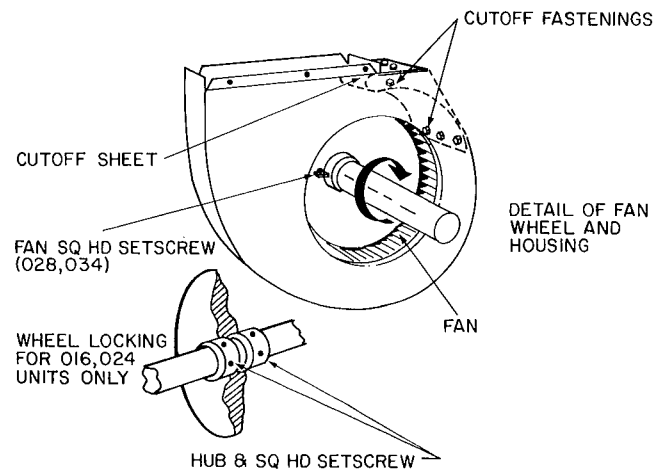

**Fig. 11 — Fan Locking Detail**

**CONCENTRIC ALIGNMENT**—Shaft and wheels must be concentrically centered with the venturi or air inlet of the fan housing.

**ALL UNIT SIZES** — Bearings are bolted to supports. To correct shaft and wheel concentric misalignment:

1. Loosen bearing support bolts and shim or move as required.
2. Retighten bearing support bolts.

**HORIZONTAL SHAFT ALIGNMENT (All Units)** — If the shaft has moved and all wheels are off horizontal center, recenter the shaft as follows:

1. Loosen setscrews holding bearing locking collar at each end of shaft.
2. Slide shaft and wheel assembly horizontally until wheels are horizontally centered (Fig. 10).
3. Slide the bearing locking collars against the bearing race; turn in direction of shaft rotation until tight.
4. Retighten locking collar setscrews.

**FAN, PULLEY AND BELT ADJUSTMENT** — Refer to the Service section entitled Indoor-Air Fan Adjustment.

**Step 9 — Install Field-Fabricated Ductwork**

Connect ducts to unit, using flexible connections as required. Duct angles are supplied with each 50BJ, BK044,054 and 064 unit. Install duct angles at duct openings using flexible connections. Connect supply ducts to flanges. Supply ducts should not be manifolded together for at least 4 feet.

Attach ductwork to building structure and insulate. Add a vapor barrier to prevent sound transmission and vapor condensation.

Weatherproof external ductwork, joints and openings with flashing and mastic in accordance with applicable codes.

Ducts passing thru an unconditioned space must be insulated and covered with a vapor barrier.

**Step 10 — Check Return Air Filters Unit 50BJ,BK (016-034 only)**

Be sure that the filters are the correct size; refer to Table 1. *Do not operate the unit without these filters in place.*

**Step 11 — Check Compressor Spring Mounts**

The compressors are held rigid in shipment by bolts extending thru a washer, lockwasher and compressor foot into a weld nut.

Loosen and remove each bolt (4 per compressor) until compressor floats free on springs. Remove and discard washer and lockwasher. Take bag provided with compressor and remove grommet and new washer. Install grommet and new washer. Replace

and tighten bolts so that there is slight pressure on grommet. This will steady compressor and prevent start and stop rocking.

The compressors have reversible oil pumps that operate in either direction; therefore the direction of rotation need not be checked.

**Step 12 — Make Condenser Connections**

**WATER-COOLED (50BJ unit) —** Condensers have water inlet and outlet connections as shown in Fig. 12. Piping arrangements for city, waste or recirculating water are shown in Fig. 13 thru 16.

Recirculating systems with low-temperature water returning to the condenser may require a water regulating valve. Units used on waste or city water must have a regulating valve on the inlet of each condenser and will require field modification for separate condenser piping. Refer to Fig. 13, 14, 15, 16 and 17 for typical applications and conversions.

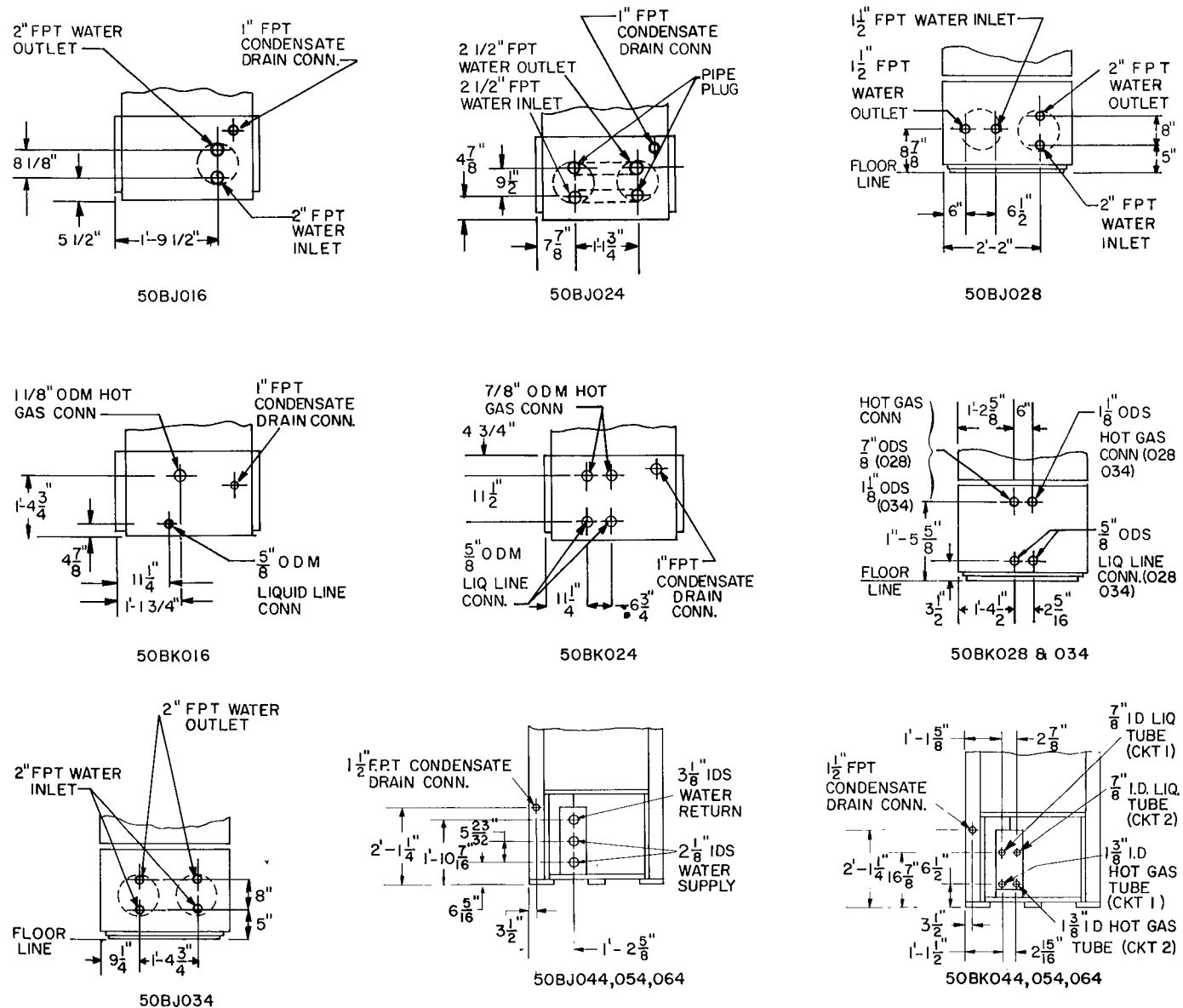

NOTE: RIGHT SIDE VIEW OF UNIT SHOWN

**Fig. 12 — Water and Refrigerant Connections**

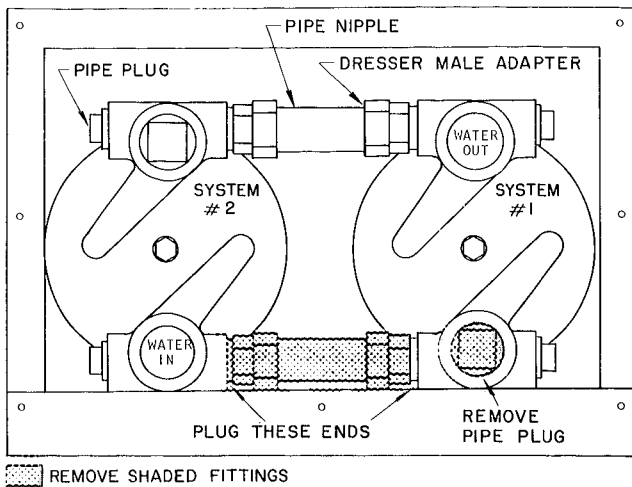

**Fig. 13 — 50BJ024 City Water Condenser Piping Conversion**

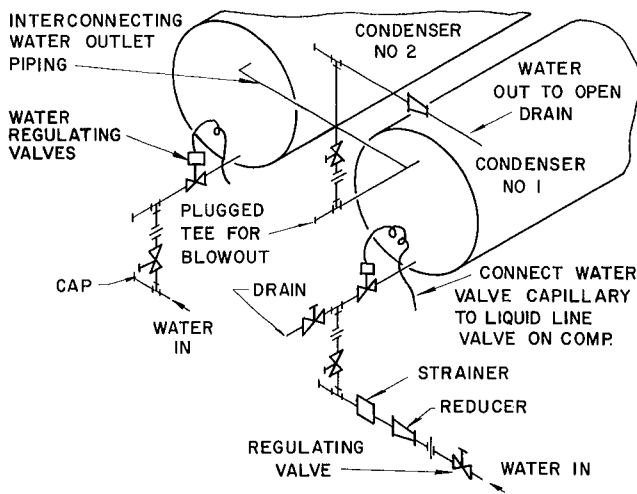

**Fig. 14 — 50BJ024 Typical Waste or City Water Piping**

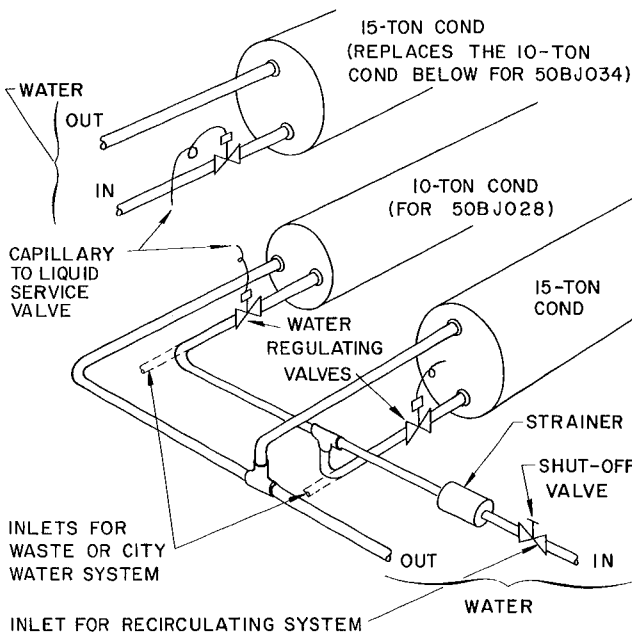

**Fig. 15 — 50BJ028 and 034 Condenser Water Piping**

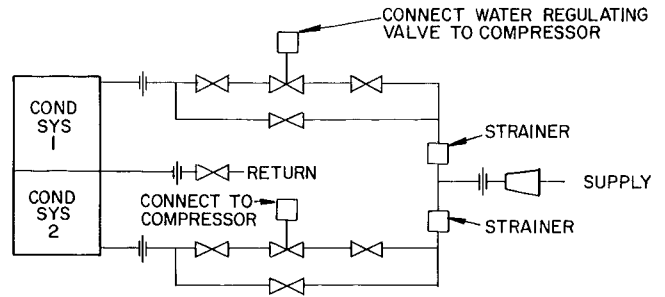

Nominal supply and return lines must be sized to provide required gallons per minute at condenser. All supply piping and valves are 2 in. Return piping is 3 in. Condensate drain is 1½ in. FPT. A field-supplied and installed external trap is required.

**Fig. 16 — 50BJ, BK044, 045 & 064 Condenser Water Piping**

Install a water regulating valve on the inlet of each condenser with any size unit used on waste or city water (Fig. 14, 15 and 16).

Connect the regulating valve capillary to a back-seated liquid service valve. Arrow on valve body must point in direction of water flow. After connecting capillary, open regulating valve one turn from back-seated position. Adjust valve as required to maintain proper condensing temperature.

Install full size gate valve and strainer in the water supply line. See maximum working pressures in Table 3. Valve and strainer must be accessible.

**Table 3 — Maximum Water-Side Working Pressure**

UNIT SIZE 50BJ, BK	MAXIMUM WORKING PRESSURE (psig)
016	550
024	150*
028, 034	550
044, 054, 064	400

\*550 psig if factory-installed dresser adapters are removed and field-fabricated manifold is installed.

**AIR-COOLED (50BK units)** — Install air-cooled condenser in accordance with the Installation Instructions shipped with condenser.

Consult Carrier System Design Manual for standard refrigerant piping techniques. Connection locations for liquid and hot gas service lines are shown in Fig. 12. Recommended line sizes are listed in Table 4.

Condenserless (50BK) units are shipped with a holding charge. After refrigerant connections are made, evacuate, leak test and charge the system as described in the Service section entitled Charging the System. Refer to Table 1 for approximate unit charge.

**Table 4 — Recommended Line Sizes (in.)  
(50BK Condenserless Models)**

UNIT 50BK	SYSTEM	CONN. SIZES*		LENGTH OF LINE (ft)					
				20		40		60-80	
		L	HG	L	HG	L	HG	L	HG
016	—	5/8	1 1/8	5/8	1 1/8	7/8	1 1/8	7/8	1 3/8
024	1 & 2	5/8	7/8	5/8	7/8	5/8	1 1/8	7/8	1 1/8
028	1	5/8	1 1/8	5/8	1 1/8	3/8	1 1/8	7/8	1 3/8
	2	5/8	7/8	5/8	7/8	5/8	1 1/8	7/8	1 1/8
034	1 & 2	5/8	1 1/8	5/8	1 1/8	7/8	1 1/8	7/8	1 3/8
044	1 & 2	7/8	1 3/8	7/8	1 3/8	7/8	1 3/8	7/8	1 5/8
054	1 & 2	7/8	1 3/8	7/8	1 3/8	7/8	1 3/8	7/8	1 5/8
064	1 & 2	7/8	1 3/8	7/8	1 3/8	7/8	1 3/8	7/8	1 5/8

HG — Hot Gas Line (OD in)

L — Liquid Line (OD in)

\*Sweat connections

**Step 13 — Install Unit Drain Line**

Install a trapped condensate drain line at unit drain connection (Fig. 12). The drain requires standard pipe connected to condensate pan nipple as shown in Table 5. Figure 18 shows proper trap design.

Determine design negative static pressure. This pressure is not the same as fan total pressure, which includes pressure losses downstream as well as upstream from the indoor air fan. Always assume the worst conditions, such as having return air filters clogged with dirt.

Referring to Fig. 18, Differential 1 must be equal to or larger than negative static pressure at design operating conditions. Store enough water in trap to prevent losing seal (Differential 2). This differential must be equal to or larger than one-half the maximum negative static pressure. When the fan starts, Differential 3 is equal to the maximum negative static pressure.

**Table 5 — Condensate Drain Connections (in.)**

UNIT SIZE	016,024	028,034	044,054,064
PIPE SIZE	1	1 1/4	1 1/2

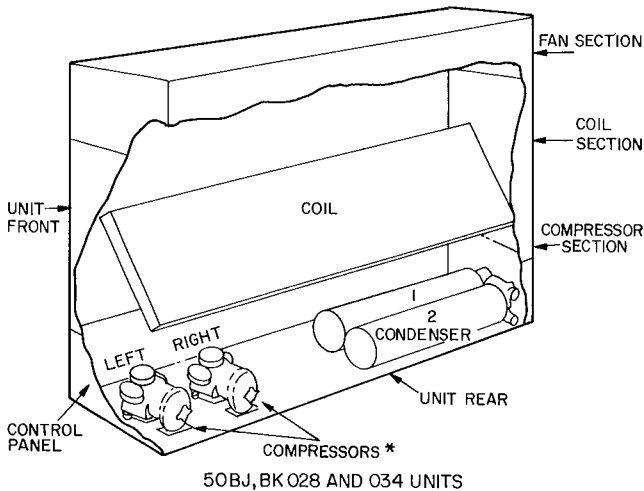

50BJ, BK 028 AND 034 UNITS

UNIT 50BJ, BK*	COMPRESSOR LOCATION	
	Left	Right
016	#1	—
024	#2	#1
028	#1	#2
034	#1	#2

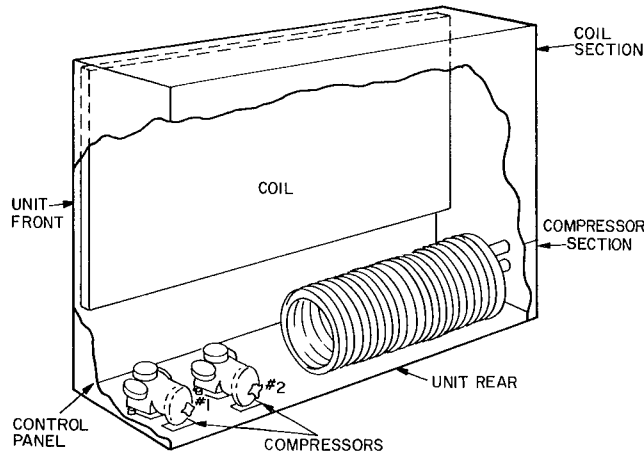

50BJ, BK 044-064 UNITS

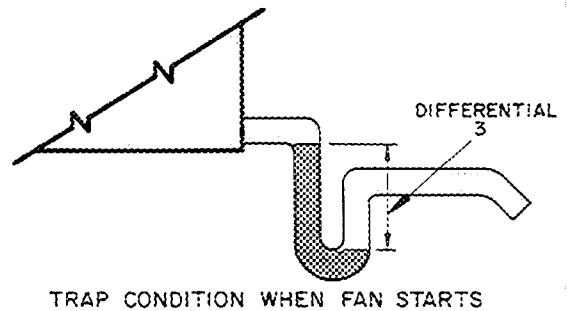
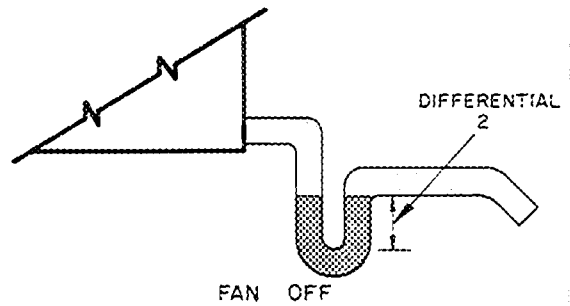
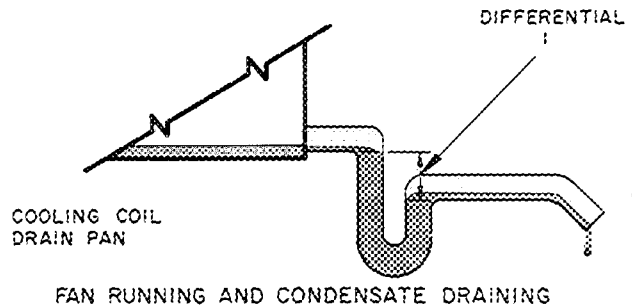

**Fig. 18 — Condensate Drain**

**Fig. 17 — Refrigerant Systems (016-064)**

Do not use drain line smaller than size listed in Table 5. If required, cut hole in panel for drain line. Pitch drain downward toward an open drain sump. Provide a trap at least 3 in. high with plugged tee for cleaning. Fill trap with water to make an air seal. Observe all sanitary codes.

#### Step 14 — Make Electrical Connections

**GENERAL** — Provide an adequate fused disconnect switch per NEC within sight from the unit. Provision for locking switch open (OFF) is advisable to prevent power from being turned on when unit is being serviced.

On all units, power may be supplied thru a branch circuit. Branch circuit protection is provided in these units by manual reset circuit breakers. Branch circuit must be in accordance with NEC or local code, whichever takes precedence. Power supplied to auxiliary equipment, such as fan motors for air-cooled condenser or for cooling tower, must be run separately.

→ **POWER WIRING** — Conduit opening for 016-034 units is on back of unit near control box. Conduit opening for 044-064 units is on top of unit near control box. On all sizes, field power connections are made at a terminal block within the control box (see Fig. 19). Refer to Table 6 for maximum wire size at terminal block.

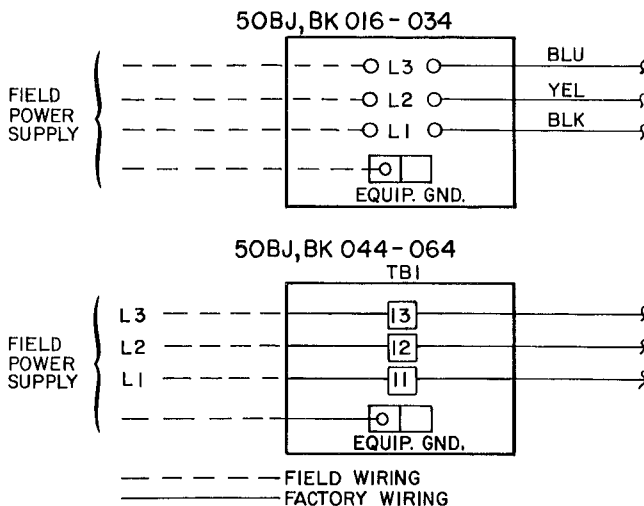

Fig. 19 — Field Power Wiring Connections

Supply voltage must be in accordance with nameplate voltage. On 3-phase units, voltage between phases must be balanced within 2% and current within 10% with compressor running. If supply voltage is not in accordance with nameplate voltage, a phase unbalance may occur. Voltage at compressor must be within the minimum and maximum shown in Table 7.

Contact local power company for line voltage corrections. Never operate a motor where a phase

unbalance in supply voltage is greater than 2%. Use the following formula to determine the % voltage unbalance:

$$\% \text{ Voltage Unbalance} = 100 \times \frac{\text{max voltage deviation from average voltage}}{\text{average voltage}}$$

Example: Supply voltage is 240-3-60.

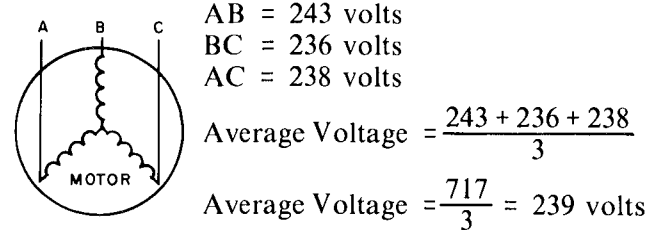

Determine maximum deviation from average voltage:

$$\begin{aligned} \text{(AB)} \quad 243 - 239 &= 4 \text{ volts} \\ \text{(BC)} \quad 239 - 236 &= 3 \text{ volts} \\ \text{(AC)} \quad 239 - 238 &= 1 \text{ volt} \end{aligned}$$

Maximum deviation is then 4 volts. To determine the % voltage unbalance:

$$\% \text{ Voltage Unbalance} = 100 \times \frac{4}{239} = 1.7\%$$

This amount of phase unbalance is satisfactory since it is below the maximum allowable of 2%.

**IMPORTANT:** If supply voltage phase unbalance is more than 2%, contact your local electric utility company immediately.

→ Compressor operation on improper line voltage or excessive phase unbalance may be considered abuse and any resulting damage may not be covered by Carrier warranty.

All wiring must be in accordance with local or NEC regulations.

**FIELD CONTROL WIRING** — On extended voltage (208-230-v) units, control transformer is factory wired for 208-v usage. If unit is to be used on 230-v system, reconnect primary wiring on transformer as shown on unit wiring diagram.

When accessory timer control panel is used, connect panel to factory-supplied control panel as indicated on unit label diagram.

→ **WINTER START-UP PACKAGE** — On 50BK 044-064 units, an accessory winter start-up package is available for providing a 3-minute time delay by shorting out the low-pressure switch on each compressor. This enables each compressor to start even during low ambient conditions.

→ **HEATING COILS** — Accessory heating coils are available for field installation. Separate installation instructions are shipped with the accessory (016-034 only). For 50BJ, BK044-064 units, refer to latest 39E (size 32) literature.

**Table 6 — Maximum Wire Size for Power Terminal Block\***

VOLTS/PHASE	UNIT 50BJ,BK				
	016	024	028,034	044†	054,064‡
208-230/3	2/0	2/0	350	350	500
460/3	2/0	2/0	2/0	350	350
575/3	2/0	2/0	2/0	350	350

\*Select wire size per NEC and connect supply wires to factory-supplied pigtail wire connectors  
 †Maximum wire size for 50BJ,BK044 units with alternate drive package is 500 MCM  
 ‡Maximum wire size for 50BJ,BK054 units with standard drive package is 350 MCM

**Table 7 — Unit Electrical Data**

UNIT	VOLTS/PH/HZ	VOLTAGE RANGE		COMP #1		COMP #2		INDOOR FAN MOTOR		POWER SUPPLY	
		Min	Max	RLA	LRA	RLA	LRA	Hp	FLA	MCA*	MOCP†
50BJ016	208-230/3/60	187	254	50.0	191	—	—	3	9.2	71.7	110
	460/3/60	414	508	22.1	86	—	—	3	4.6	32.2	50
	575/3/60	518	632	17.9	69	—	—	3	3.7	26.2	40
50BJ024	208-230/3/60	187	254	36.0	137	36.0	137	5	13.2	94.2	125
	460/3/60	414	508	16.0	62	16.0	62	5	6.6	42.6	50
	575/3/60	518	632	12.9	50	12.9	50	5	5.6	35.1	45
50BJ028	208-230/3/60	187	254	49.3	191	35.7	137	7½	22.0	120.0	150
	460/3/60	414	508	22.2	86	16.0	62	7½	11.0	54.8	70
	575/3/60	518	632	18.0	69	13.0	50	7½	8.7	44.2	60
50BJ034	208-230/3/60	187	254	49.3	191	49.3	191	7½	22.0	132.9	175
	460/3/60	414	508	22.2	86	22.2	86	7½	11.0	61.0	80
	575/3/60	518	632	18.0	69	18.0	69	7½	8.7	49.2	60
50BJ044	208-230/3/60	187	254	57.9	283	57.9	283	15	46.2	178.5	225
	460/3/60	414	508	26.5	142	26.5	142	15	21.0	82.7	100
	575/3/60	518	632	22.2	98	22.2	98	15	15.4	64.7	80
50BJ054	208-230/3/60	187	254	80.8	446	60.0	283	20	59.4	222.4	300
	460/3/60	414	508	35.8	223	26.5	142	20	27.0	100.3	125
	575/3/60	518	632	30.0	164	22.2	98	20	20.0	81.5	110
50BJ064	208-230/3/60	187	254	91.5	446	91.5	446	25	74.8	282.7	350
	460/3/60	414	508	42.6	253	42.6	253	25	34.0	131.9	150
	575/3/60	518	632	32.2	164	32.2	164	25	25.6	100.1	125
50BK016	208-230/3/60	187	254	64.0	266	—	—	3	9.2	89.2	150
	460/3/60	414	508	29.0	120	—	—	3	4.6	40.9	60
	575/3/60	518	632	23.0	96	—	—	3	3.7	32.5	50
50BK024	208-230/3/60	187	254	45.0	170	45.0	170	5	13.2	114.5	150
	460/3/60	414	508	20.0	77	20.0	77	5	6.6	51.6	70
	575/3/60	518	632	16.0	62	16.0	62	5	5.6	41.6	50
50BK028	208-230/3/60	187	254	64.0	266	45.0	170	7½	22.0	147.4	200
	460/3/60	414	508	29.0	120	20.0	77	7½	11.0	67.3	70
	575/3/60	518	632	23.0	96	17.0	62	7½	8.7	54.7	70
50BK034	208-230/3/60	187	254	64.0	266	64.0	266	7½	22.0	166.0	200
	460-3/60	414	508	29.0	120	29.0	120	7½	11.0	76.3	100
	575/3/60	518	632	23.0	96	23.0	96	7½	8.7	60.5	80
50BK044	208-230/3/60	187	254	77.2	345	77.2	345	15	46.2	221.9	250
	460/3/60	414	508	35.8	173	35.8	173	15	21.0	103.6	125
	575/3/60	518	632	30.0	120	30.0	120	15	15.4	84.9	110
50BK054	208-230/3/60	187	254	101.5	446	77.2	345	20	59.4	265.5	350
	460/3/60	414	508	48.6	223	37.9	173	20	27.0	127.7	175
	575/3/60	518	632	38.6	164	30.0	120	20	20.0	100.3	125
50BK064	208-230/3/60	187	254	120.0	506	120.0	506	25	74.8	346.8	450
	460/3/60	414	508	56.5	253	56.5	253	25	34.0	163.2	200
	575/3/60	518	632	42.9	176	42.9	176	25	25.6	124.2	150

FLA — Full Load Amps  
 Hp — Nominal Horsepower  
 LRA — Locked Rotor Amps  
 MCA — Minimum Circuit Amps  
 MOCP — Maximum Overcurrent Protection Device (amps)  
 RLA — Rated Load Amps

\*Minimum circuit amps (MCA) for wire sizing complies with NEC Section 430-24

†In compliance with NEC requirements for multimotor and combination load equipment (Ref NEC Articles 430 and 440), the overcurrent protective device for the unit shall be fuse only

**NOTES:**

1 Compressor circuit breakers are current sensitive and temperature compensated to ensure compressor cutoff if current draw becomes excessive. Breakers must be manually reset

- 2 Discharge gas thermal protection or internal protection with automatic reset de-energizes the control circuit if extreme compressor motor temperature should occur from excessive gas temperature or motor overloading
- 3 Low- and high-pressure switches automatically shut off compressor(s) if refrigerant pressure exceeds switch settings. This action protects against loss of charge
- 4 Indoor fan motor circuit breaker protects against motor overload. Breaker requires manual reset
- 5 The 50BJ,BK units are ETL listed at 208/230 and 460 v and C S A certified at 575 v
- 6 Phase imbalance shall not exceed 2%
- 7 Wire sizing amps are a sum of 125% of the FLA for the largest motor plus 100% of FLA for all other motors in the unit
- 8 Maximum instantaneous current flow during starting is the sum of the LRA for last compressor to start plus the FLA for all other compressors in the unit

## START-UP

**General** — The 50BJ,BK units are designed for use in Modu-Vac Variable Air Volume Systems using Carrier 37A Moduline® and 35B Modubox Air Terminals. For air terminal installation and adjustment, refer to 37A or 35B literature as required.

**CAPACITY CONTROL** — The units are equipped with electric unloaders on the lead compressor (Fig. 17) and hot gas bypass on the no. 1 refrigerant system. (Size 016 units have only one refrigerant system.)

Unit capacity is monitored and controlled by a Honeywell W7100 microprocessor (Fig. 20). This controller provides the number of capacity control steps as shown in Table 8.

**Table 8 — Capacity Control Steps**

UNITS 50BJ,BK	CAPACITY CONTROL (No. Steps)
016	3
024,028,034	6
044	4
054,064	6

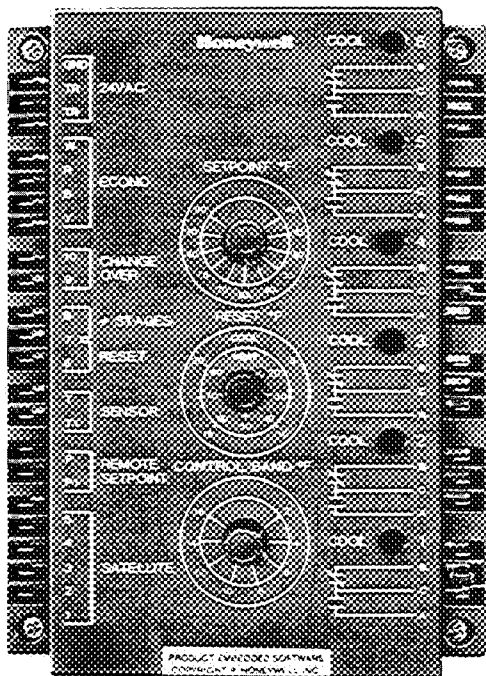

**Fig. 20 — Honeywell Microprocessor**

**TIMER CONTROL** — Carrier strongly recommends use of an accessory timer control panel with the 50BJ,BK units. Installation and adjustment of this device (Fig. 21) is covered in separate Installation, Start-Up and Service Instructions included in the accessory package.

If accessory timer is not used, install field-installed manual switch between TB3 terminals **1** and **8** in the variable volume control box for the 016-034 units. Switch is factory-installed on the 044-064 units.

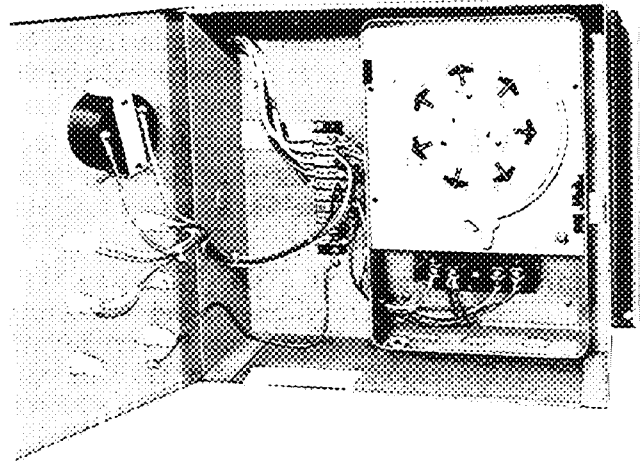

**Fig. 21 — Accessory Timer Control Panel**

**MOISTURE INDICATORS** are located ahead of thermal expansion valves. They must be full of liquid to properly indicate moisture content. Operate system for 30 minutes before determining moisture content.

**SERVICE VALVES (50BK)** — Valves use teflon seat washers to ensure position seal with minimum stem torque (10 lb-ft max). Do not overtighten valve stem. Use wet rag on valve when soldering. If refrigerant has been lost, midseat valve. Always replace stem cap.

### Prior to Unit Start

1. Clean and inspect the unit.
2. Open (backseat) compressor service valves and liquid line shutoff valves. Replace and tighten valve caps to prevent leakage.
3. On 50BK (air-cooled condenser) units, turn on indoor fan motor circuit breaker. Check that compressor crankcase heaters are energized and crankcase oil level is half full.
4. Leave crankcase heaters energized for 24 hours to ensure safe oil/refrigerant mixture in crankcases for unit start-up.

### Control Sequence Checkout

1. Perform all applicable steps described above under Prior to Unit Start.
2. Turn on unit main power supply.
- 3. Set the control band knob on microprocessor (Fig. 20) at 2.
4. Turn on indoor fan motor circuit breaker.
5. If unit is equipped with accessory timer control panel and 7-day clock is not calling for cooling, turn on unit by overriding clock with manual bypass switch (see Start-Up General section entitled, TIMER CONTROL).
6. Close compressor circuit breakers.
7. Check for cooling by turning microprocessor SETPOINT knob to 40 F. Light-emitting diodes

(LEDs) should glow as corresponding cooling stages come on. In addition, indicating lights on cover of accessory timer control panel should light.

→ NOTE: Depending on job conditions and differential between setpoint and discharge temperatures, minimum time for all stages to come on is 22 minutes.

8. Turn microprocessor SETPOINT knob to 90 F. The LEDs on microprocessor and indicating lights on accessory timer control panel should go off as corresponding cooling stages drop out. Ambient temperature must be less than 90 F for this test.
9. When checkout and unit operation are satisfactory, turn off manual bypass switch (step 5), position microprocessor SETPOINT knob at desired temperature (approximately 55 F) and replace all unit panels.

### SERVICE

**WARNING:** Lock open and tag unit disconnect before servicing equipment.

**CAUTION:** Before servicing fan compartment.

1. Sharp edges of evaporator coil fins are exposed. To prevent arm injury, cover top edge of evaporator with strip of cardboard or a few layers of heavy tape.
2. To avoid coil damage, cover coil face with a piece of plywood or other suitable rigid sheet material. If any coil fins are mashed or bent, straighten with a coil fin comb. Check for refrigerant leaks.

**Fan Rotation** — Correct fan rotation in respect to fan outlet is shown in Fig. 22. To check for proper fan rotation, remove service access panels and jog fan motor switch. If fan rotation is incorrect, it must be reversed.

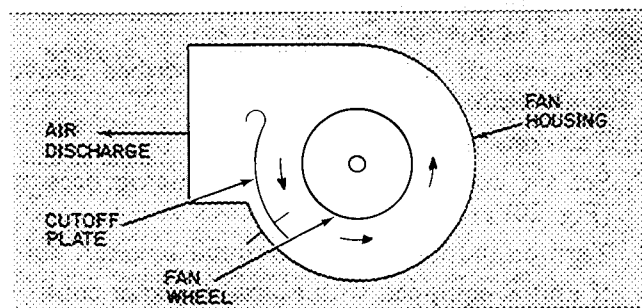

Fig. 22 — Fan Rotation

To reverse the direction of rotation of a 3-phase fan motor reverse any 2 of the power leads. Refer to the connection diagram on the inside of motor terminal box cover for proper reversing procedure of single-phase motor.

1. Pulleys and fan belts should be aligned and adjusted as shown in Fig. 23-25.
2. Tighten motor hold-down bolts.
3. Replace service access panels.

**Indoor-Air Fan Adjustment** — Fan motor pulley is factory set for speed shown in Table 1. Unit sizes 028-064 have fixed pulleys. A second pulley is shipped with drive package.

Increasing fan speed increases load on motor. Do not exceed maximum allowable fan speed (Table 1) or motor full load amps shown on motor nameplate and in Table 7.

### → TO CHANGE FAN SPEED

1. Shut off power supply.
2. Loosen fan belt by loosening fan motor on mounting bracket. Do not loosen mounting bracket from unit.
3. Loosen movable pulley flange setscrew (016,024). See Fig. 25.
4. Select motor pulley diameter. See Table 1.
5. To increase fan speed, screw movable flange towards fixed flange; to decrease speed, screw movable flange away from fixed flange. Use values shown in Table 1 (016,024).
6. Set movable flange setscrew at nearest pulley hub flat and tighten (016,024).
7. Check pulley alignment and adjust belt tension as described below.
8. Check fan operation. Repeat above procedure as required.

**V-BELT INSTALLATION AND TENSIONING** (See Fig. 23, 24, 25 and 26) — Use the following steps when installing drive belts:

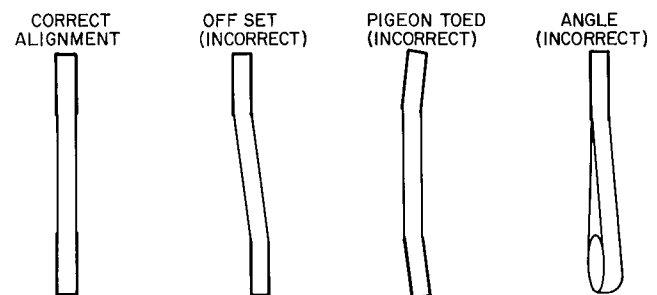

Fig. 23 — Fan Belt Alignment

**Step 1 — Sheave Conditions** — Check condition of all new and old sheaves. Sheave must have smooth finish and no sharp edges or burrs. Check for groove uniformity. Excessively worn sheaves or improperly machined grooves can lead to early belt failure. Non-uniformity of grooves will create an unequal load distribution in matched set of belts.

**Step 2 — Mounting Sheaves** — Mount sheaves as close to bearing as possible. Excessive overlap may cause bearing failure.



Step 3 — Matched Set of Belts — Always use matched set of belts. *NEVER mix new and used belts and/or mix belts from different manufacturers.*

Step 4 — Belt Installation:

- Move pulleys together to facilitate belt installation. *NEVER pry or roll belt on to pulleys as this may cause serious damage to belts.*
- Work belts around pulleys by hand. All belts should be slack on same side of drive. *Mixing slack and tight sides together may result in serious damage to belts when drive is tensioned.*

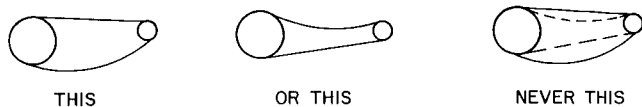

Fig. 24 — Fan Belt Adjustment

- Move pulleys apart until belts are snug. Make preliminary check of sheave and shaft alignment. Operate drive at no load for several minutes to seat belts and then check belt tension. *Excessively high or low tensions adversely affect the life and operation of V-belts.*
- Check sheave and shaft alignment after belt tension is applied.

**PULLEY ALIGNMENT** — **Shut off unit power supply.** Make sure motor and fan shafts are parallel. Align shafts by loosening motor on mounting bracket if required. Then loosen fan pulley setscrews, slide pulley along fan shaft and align with straightedge as shown in Fig. 25.

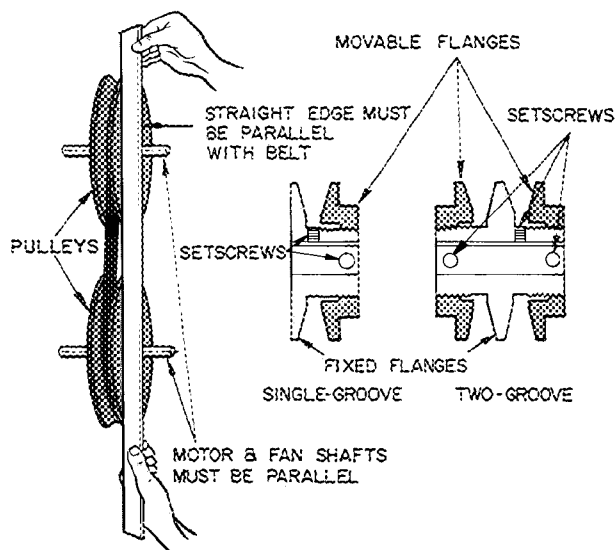

Fig. 25 — Indoor Air Fan Pulley Adjustment and Alignment

**TENSIONING** (See Fig. 26) — Use the following steps when adjusting belt tension:

Step 1 — Measure belt span in inches.

Step 2 — Use spring scale at center of span to deflect belt 1/64 inch for every inch of span length. Record scale reading.

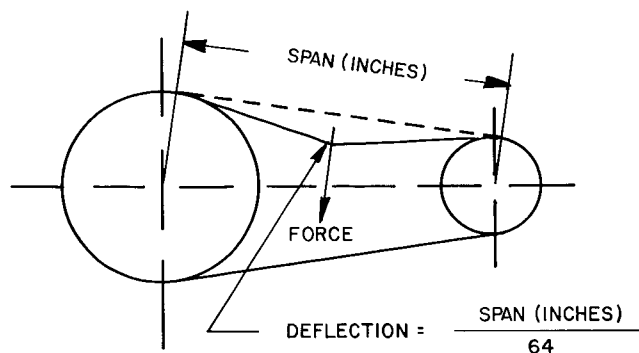

Fig. 26 — Fan Belt Tensioning

Example: For span of 10 inches — deflection will be  $\frac{10}{64}$  or  $\frac{5}{32}$  inch.

Step 3 — Spring scale reading should be in range of 12 to 18 pounds. Maximum tension for a new belt is 18 pounds.

Step 4 — Adjust tension to maximum after 15 minutes. Check belt tension after 2 to 4 hours of operation.

Step 5 — After 24 to 48 hours of operation, check drive to see if normal tension is obtained. *Excessively high or low tension will adversely affect life and operation of V-belt.*

**Lubrication** — **Shut off power supply.** *Protect coil from damage.*

Fan motor bearings are factory lubricated and will need no lubrication for the first 5 years of operation (3 years with continuous service or excessively dirty conditions).

Inspect bearings and relubricate or replace as required. Follow manufacturer's instructions for lubrication of special field-supplied motors.

Fan shaft bearings on 50BJ, BK016 and 024 units are lubricated for the life of the bearings. Bearings for 50BJ, BK028 thru 064 units have grease fittings. On 50BJ, BK044-064 units the fan shaft universal joint requires the same lubrication as the bearings. Lubricate annually with a good grade of mixed base grease or lithium base grease with rust inhibitor. Add grease until air bubbles form under the seal. Do not overgrease.

**Return-Air Filters** — Inspect filters twice monthly and replace as often as required by operating conditions. Filter type and size is given in Table I.

If field-supplied, cleanable filters are used, flush them with hot water or steam, or soak them in a mild solution of soap or detergent and water. Refer to filter manufacturer's instructions as applicable.

*Never operate the unit without return-air filters in place.*

**Condensate Drains** — Clean drain line and unit drain pan at start of each cooling season. Check flow by pouring water into drain. Be sure trap is filled to maintain air seal (Fig. 18).

**Evaporator Coil** — Protect coil when working inside unit. (See screened CAUTION note, page 15.)

Remove dirt and debris from evaporator coil as required. Clean with a stiff brush, vacuum cleaner or compressed air. Straighten mashed or bent coil fins with a fin comb of the correct spacing. Table 1 lists the fins per inch for each coil.

**Water-Cooled Condenser(s)** may require cleaning of scale (water deposits). Contact local water treatment company for best results.

**Air-Cooled Condensers** — Periodically inspect and clean depending on operating conditions. Follow the service instructions provided with the air-cooled condenser used.

**Sight Glasses** are provided at the inlet of each expansion valve. Units may be field charged by using the sight glass (see Charging the System).

→ **Charging the System**

**UNITS WITH WATER-COOLED CONDENSER (50BJ)** — Units are shipped with a full operating charge of refrigerant. If recharging is necessary (complete charge lost) weigh in amount of refrigerant indicated on unit nameplate and Table 1.

If unit has a partial charge, unit may be charged with sight glass using standard charging techniques. See Carrier Standard Service Techniques Manual entitled Chapter 1, Refrigerants for applicable procedures.

Adjust the water regulating valve to proper saturated condensing temperature (168 to 226 psig).

**UNITS WITH AIR-COOLED CONDENSER (50BK)** — Units are shipped with a holding charge only. To charge:

1. Open suction and discharge line service valves.
2. Blow holding charge, evacuate and leaktest system.
3. Add sufficient refrigerant vapor to permit continuous operation after starting unit.
4. Start unit per Start-Up Section; then, using standard charging techniques, add refrigerant as required to maintain normal operating conditions.

Use charging chart supplied with condenser. If information is not available, block off enough of condenser coil to maintain 220 psig discharge pressure and charge to a clear sight glass.

**Indoor-Air Fan Motor Removal**

Shut off and lockout unit power supply.

**▲ CAUTION**

Before attempting to remove fan motors or motor mounts, place a piece of plywood over evaporator coils to prevent coil damage.

**ALL 50BJ, BK UNITS** — Remove motor as follows:

1. Remove unit access panel and cover of motor junction box.
2. Disconnect motor wires and remove conduit connection.
3. Remove motor bolts and slide motor over so that fan belt can be removed.
4. Disconnect motor ground wire (if present) and remove motor.

**TO REINSTALL MOTORS** — Reverse the above procedures. Align pulleys and adjust belt tension as described in the section, Indoor-Air Fan Adjustment.

**Pressure Relief Devices** — The 50BK (condenserless) and 50BJ, BK044-064 units are equipped with a fusible-plug type safety relief device on the compressor. The relief setting is 197 or 203 F on all units.

All 50BJ (water-cooled) units have a frangible disc on each condenser. Disc setting is 385 ± 5% psig.

→ **Crankcase Heaters** are supplied on all 50BK (condenserless) units and on 50BJ044-064 water-cooled units.

The heater reduces the possibility of liquid refrigerant from accumulating in the compressor crankcase during extended shutdown periods. Heater is automatically energized whenever unit main power is on and compressor is stopped. Heater is de-energized when compressor starts.

Do not shut off unit main power supply for an extended period except for servicing unit. After an extended shutdown period, turn power supply on at least 24 hours prior to starting compressor.

If 50BJ units are installed in unheated rooms, they should be equipped with crankcase heaters. All units equipped with crankcase heaters require 24 hours warm up time.

**High-and Low-Pressure Switches** — The high-pressure switch is located in the electrical panel. The low-pressure switch is located on top of compressor.

**Time Guard® Control Circuit** provides automatic reset protection (except circuit breaker), time delay in starting and controlled cycling. If compressor shuts down for any reason, the control circuit prevents restart for time periods as follows:

UNIT 50BJ, BK	CIRCUIT NO.	A	B
		Full Cycle (minutes)	Delayed Start (seconds)
016	1	5	15
024, 028, 034	1 2	6 4 5	19 15
044, 054 064	2 1 and 2	5 6 4	15 19

Column B shows time delay between compressor starts under normal thermostat cycling.

## CONTROL SEQUENCE

**All 50BJ,BK Units** — The indoor fan circuit breaker (IFCB) must be closed for the control circuit to be energized. When breaker is closed, the SYSTEM light will be on.

The 044-064 units are equipped with a switch labeled STANDBY. When switch is closed, the indoor fan contactor (IFC) is energized and the indoor fan will start and run continuously. A light labeled FAN will come on. To use accessory timer control, switch must be put in STANDBY position.

All units are equipped with the improved Honeywell W7100 discharge air controller. Controller has 3 control knobs: set point, reset and control band. Controller regulates the leaving air temperature to the set point. A setting below 50 F may decrease unit efficiency due to use of hot gas bypass at light loads. The reset knob adjusts reset control range from 5 F to 20 F. The reset feature requires field-supplied components and wiring. The control band knob adjusts controller for the required number of stages. The control band should be set at 6 F for the 016-034, 054 and 064 units, and 8 F for the 044 units. Increasing control band setting above these recommended settings will decrease compressor cycling and increase leaving air temperature variations. Decreasing setting will *not* reduce discharge air temperature variations but will increase compressor cycling.

The controller is also factory equipped with 2 fixed resistors. One resistor corrects for the number of steps. This is done by placing a 1/4-watt, 5%-resistor across terminals **7** and **8** on micro-processor. A 3-stage, 300-ohm resistor is used on the 016 unit. A 4-stage, 400-ohm resistor is used on 044 units and a 600-ohm resistor is used on 024-034, 054 and 064 units. A second 510-ohm resistor is connected between terminals **9** and **Y** to indicate unit does not have an economizer. These units do not have a factory-supplied economizer. If a field-supplied economizer is added, remove the 510-ohm resistor. Consult Carrier Corporation for more details.

If the discharge air deviates 1° F above or below the control band while unit is running, a cooling capacity stage will either be added or removed according to the loading sequence table found on page 18. Additional capacity steps will be turned on or off until discharge air temperature is within control band or is charging at a rate that will allow it to be within control band within 10 minutes. The controller also has a fixed guaranteed minimum on and off time of 4 minutes to prevent compressor cycling.

These units are equipped with a Time Guard® circuit. This circuit prevents compressor no. 1 from restarting until 4 minutes, 45 seconds have elapsed from last shutdown. Compressor no. 2 will not restart until 6 minutes, 10 seconds have elapsed.

Each compressor is equipped with a high-pressure switch (HPS), discharge gas thermostat (DGT) or internal protection (IP) and low-pressure switch (LPS). If any of these “trip”, the compressor will shut down. If, after 4 minutes, 45 seconds for compressor no. 1 and 6 minutes, 10 seconds for compressor no. 2, the switch resets, compressor no. 1 will restart within 15 seconds and compressor no. 2 within 19 seconds.

The 50BK condenserless units are equipped with a liquid line solenoid (LLS). When a stage calls for compressor shutdown, the liquid line solenoid will close first. The compressor will continue to run until the low-pressure switch opens.

### Loading Sequence

MODEL 50BJ,BK	STAGE					
	1	2	3	4	5	6
016	33%	67%	100%	—	—	—
024	17%	34%	50%	67%	84%	100%
028	17%	34%	50%	67%	84%	100%
034	17%	34%	50%	67%	84%	100%
044	25%	50%	75%	100%	—	—
054	19%	38%	57%	63%	84%	100%
064	17%	34%	50%	67%	84%	100%

For replacement items use Carrier Specified Parts

Manufacturer reserves the right to discontinue, or change at any time, specifications or designs without notice and without incurring obligations

Book	1
Tab	2a

Form 50BJ,BK-4SI Supersedes 50BJ,BK-2SI

Printed in U S A

6-83

PC 111

Catalog No 535-031