

Installation Instructions

NOTE TO INSTALLER: Leave these instructions, the User's Manual, and Parts Replacement Guide with the unit after installation.

▲ WARNING

Improper installation, adjustment, alteration, service, maintenance, or use can cause carbon monoxide poisoning, explosion, fire, electric shock, or other occurrences which may injure you or damage your property. Consult a qualified installer, service agency, or the gas supplier for information or assistance. The qualified agency must use factory authorized kits and accessories when modifying this unit.

NOTE: The installation of this unit must conform to the guidelines presented in these unit Installation Instructions. Read and become familiar with this publication before starting the installation.

INTRODUCTION

Model 48N Packaged Gas/Electric Unit is fully self-contained, combination gas heating/electric cooling unit designed for outdoor installation. Model 48N may be installed either on a rooftop or ground-level slab. See Fig. 1. For rooftop downflow applications, an accessory roof-mounting curb must be used.

Model 48N Unit meets the California maximum oxides of nitrogen (No_x) emission regulations.

These units are equipped with an energy-saving, automatic, intermittent, electric spark ignition system that does not have a continuously burning pilot. All units are manufactured with natural gas controls.

These units are designed for a minimum continuous return air temperature of 60°F. (dry bulb) or an intermittent operation down to 55°F. (dry bulb) such as when used with a night set back thermostat.

Model 48N is A.G.A. and C.G.A. design-certified. See Tables 2 thru 7 for the heating input ratings.

These units are factory-charged with R-22 refrigerant. Installation is simple: connect gas supply, air ducts, high- and low-voltage wiring, condensate drain, and install a field-supplied air filter.

All units can be connected into existing duct systems *that are properly sized and designed to handle an airflow of 350 to 450 Cfm per each 12,000 Btuh of rated cooling capacity.* See Tables 2 thru 7 for cooling and heating airflow requirements.

NOTE: When installing any accessory item, see the manufacturer's Installation Instructions packaged with the accessory. The Qualified Agency must use factory authorized kits or accessories when modifying this unit.

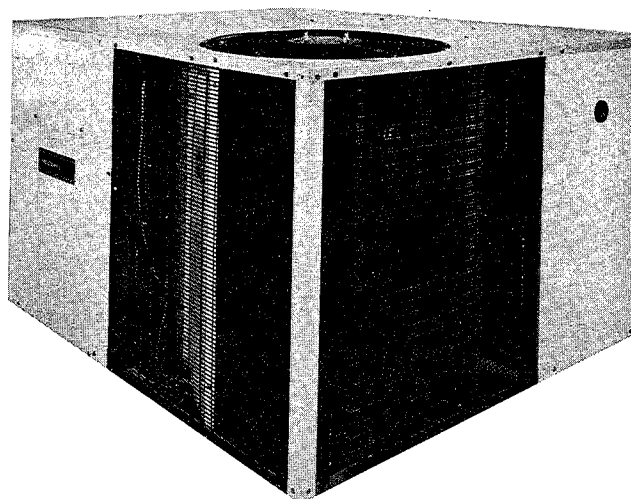

Fig. 1—Model 48N

A87316

IMPORTANT—READ BEFORE INSTALLING

1. This installation must conform with all applicable local and national codes.
2. The power supply (volts, hertz, and phase) must correspond to that specified on unit rating plate.
3. The electrical supply provided by the utility must be sufficient to handle load imposed by this unit.
4. Refer to the 48N dimensional drawing for locations of gas inlet, electrical inlets, condensate drain, duct connections, and required clearances before setting unit in place. Figs. 2 and 3.
5. Locate the unit where the vent cap will be a minimum of 4-ft from openable windows or doors.
6. This installation must conform with local building codes and with the National Fuel Gas Code ANSI Z223.1-1984 and Addenda Z223.1a-1987 (In Canada, CAN/CGA B149.1, (2)-M86) or NFPA 54-1984 TIA-54-84-1. Refer to Provincial and local plumbing or wastewater codes and other applicable local codes.
7. For outdoor installation on wood flooring or on class A, B, C roof covering materials.

GENERAL

Model 48N Packaged Gas/Electric Unit has been designed and tested in accordance with ANSI Z21.47-1987, ARI Standard 210-81, and ARI Standard 270-84, CAN/CGA-2.3-M86, CAN 1-2.17-M80, CAN 1-2.21-M85, CSA C22.2 No. 0-1982, No. 3-1979 and No. 119-M1985. The appliance design is certified by the American Gas Association (A.G.A.) and Canadian Gas Association (C.G.A.) for use with natural or LP (propane) gases with appropriate controls and orifices.

Manufacturer reserves the right to discontinue, or change at any time, specifications or designs without notice and without incurring obligations.



Unit Weights

Unit	Shipping Wt.		Operating Wt.				Corner Wt. lbs.			
	lbs.	lbs.	A	B	C	D	A	B	C	D
48NLT018	47D	450	99	126	126	99				
48NLT024	47A	454	100	127	127	100				
48NLT030	490	470	103	132	132	103				
48NHT024	480	460	101	129	129	101				
48NMT030	486	476	105	133	133	105				
48NLT036	506	486	107	136	136	107				
48NLT042	516	496	109	139	139	109				
48NHT030	500	480	106	134	134	106				
48NMT036	510	490	108	137	137	108				
48NMT042	520	500	110	140	140	110				

48N REQUIRED CLEARANCES (inches)

Above unit top 48
 Blower access panel side 30
 Duct side of unit 6 min.
 Side opposite blower access panel 30
 Side opposite ducts 30
 Bottom of unit 0
NOTE: Provision must be made for fresh ambient air to reach the outdoor coil without recirculation of the air from the outdoor fan discharge.

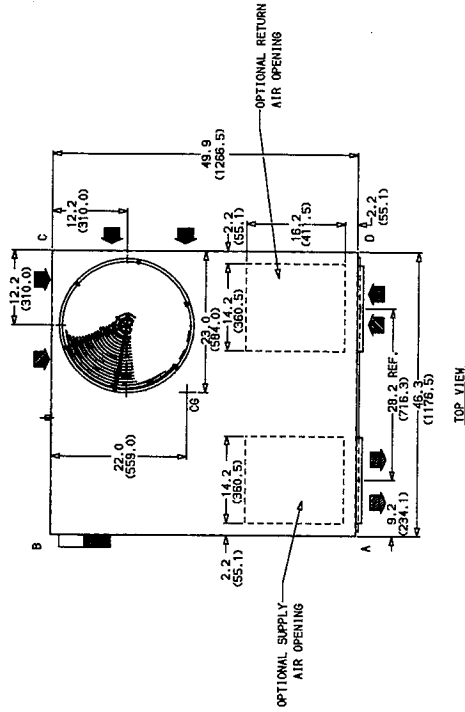

TOP VIEW

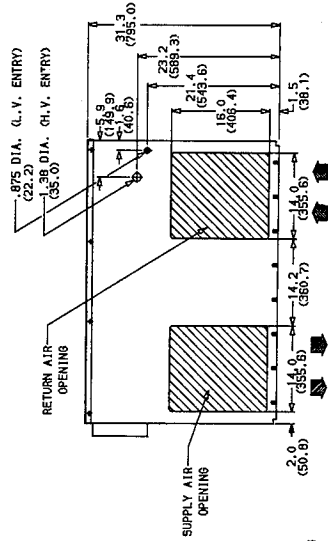

REAR VIEW

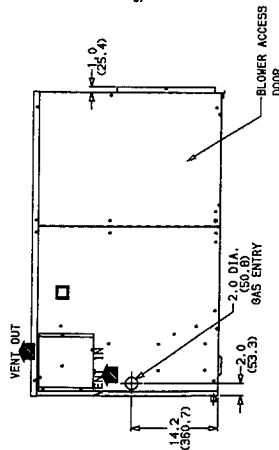

RIGHT SIDE VIEW

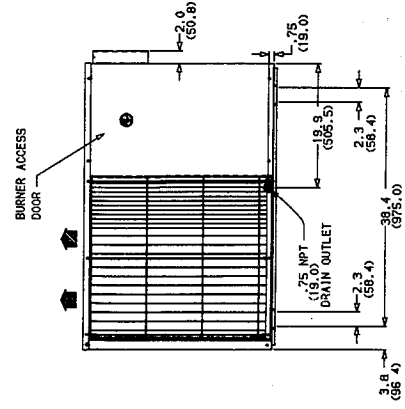

FRONT VIEW

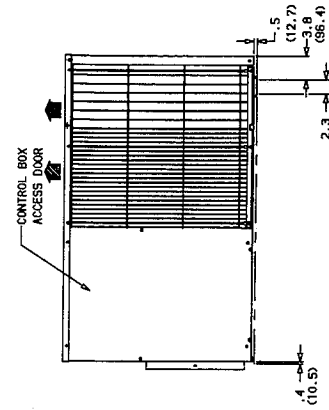

LEFT SIDE VIEW

Fig. 2— DIMENSIONAL DRAWING
 Model 48N— Sizes 48NLT018 thru 48NMT042



Unit Weights

Unit	Shipping Wt.		Corner Wt. lbs.			
	lbs.	lbs.	A	B	C	D
48NHT036	550	530	117	147	148	118
48NVT036	556	536	119	148	149	120
48NHT042	570	550	122	152	153	123
48NVT042	576	556	124	153	154	125
48NLT048	594	574	128	158	159	129
48NMT048	600	580	130	159	160	131
48NHT048	606	586	131	161	162	132
48NLT060	624	604	136	165	166	137
48NMT060	630	610	138	166	167	139
48NHT060	636	616	139	169	169	140

48N REQUIRED CLEARANCES (Inches)

Above unit top 48 Blower access panel side 30
 Duct side of unit 6 min. Side opposite blower access panel 30
 Side opposite ducts 30 Bottom of unit 0
NOTE: Provision must be made for fresh ambient air to reach the outdoor coil without recirculation of the air from the outdoor fan discharge.

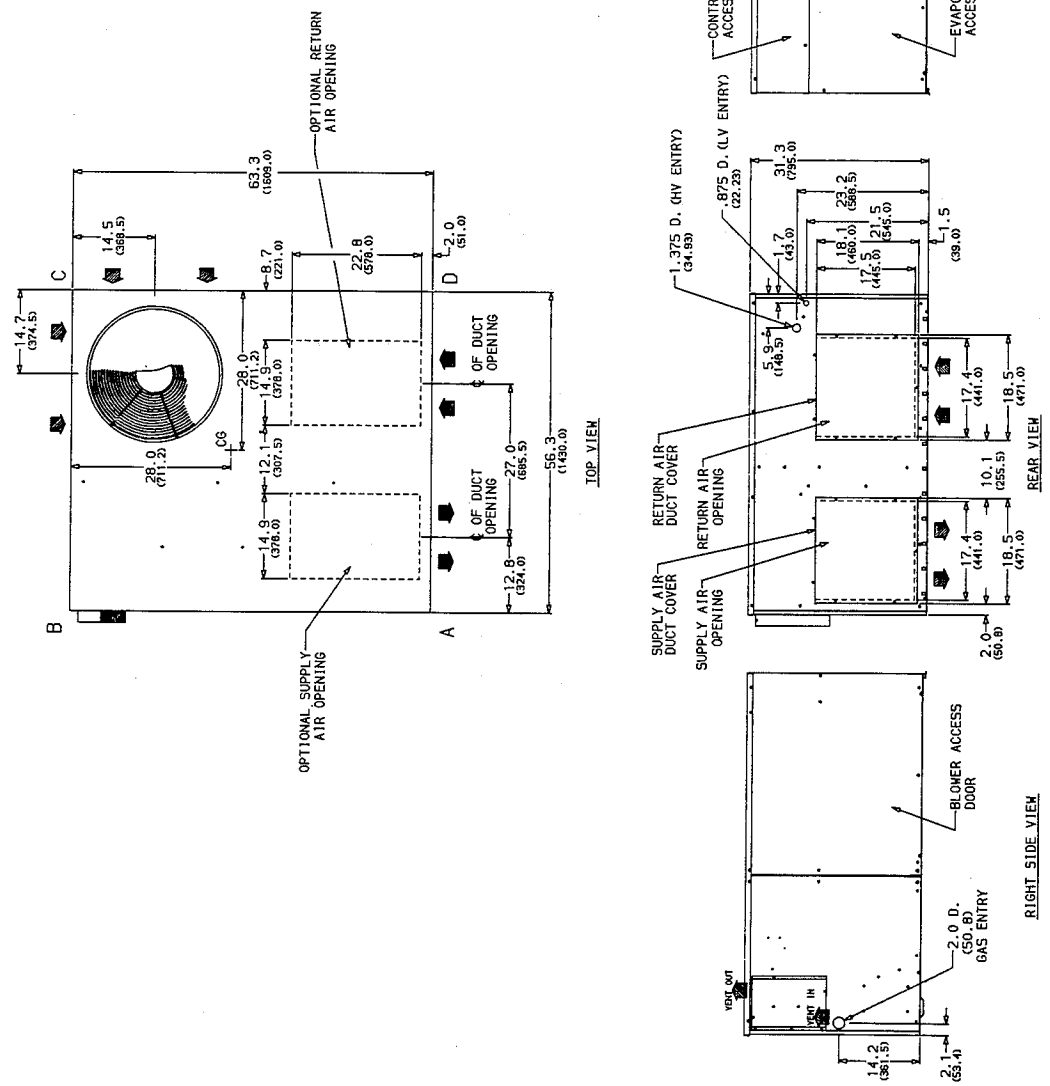

Fig. 3—DIMENSIONAL DRAWING
 Model 48N—Sizes 48NHT036 thru 48NHT060

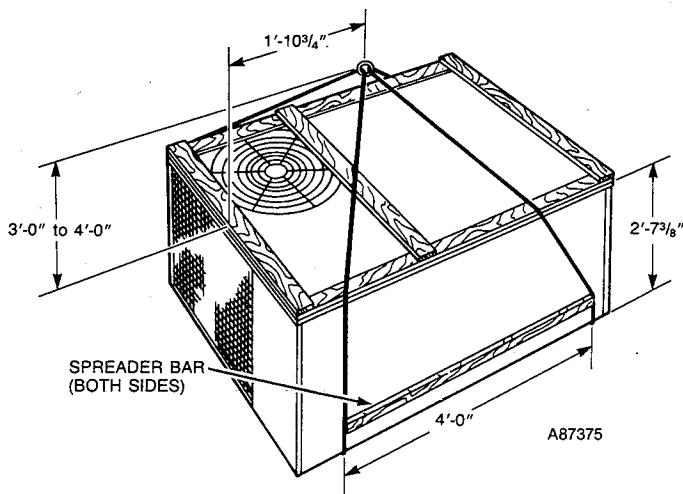

Fig. 4—Suggested Rigging

This publication contains the following:

- Step 1. Moving and Setting Unit in Place
- Step 2. Condensate Disposal
- Step 3. Venting
- Step 4. Gas Piping
- Step 5. Duct Connections
- Step 6. Electrical Connections
- Step 7. Preparing Unit for Startup
- Step 8. Heating Section Startup and Adjustments
- Step 9. Cooling Section Startup and Adjustments
- Step 10. Care and Maintenance

Step 1—Moving and Setting Unit in Place

▲ CAUTION

Use spreader bars and crate top when rigging the unit to be lifted. Model 48N must be rigged for lifting as shown in Fig. 4. Use extreme caution to prevent damage when moving the unit. Unit must remain in an upright position during all rigging and moving operations. The unit must be level for proper condensate drainage; therefore, the ground-level pad or accessory roof-mounting curb must be level before setting the unit in place. When a field-fabricated support is used, ensure that the support is level and properly supports the unit.

A. Rooftop Installation

▲ CAUTION

When installing the unit on a rooftop, be sure that the roof will support the additional weight. Refer to Figs. 2 & 3 for Model 48N to obtain total weight and corner weight information.

For downflow applications, an accessory roof-mounting curb must be installed on, and flashed into the roof before unit installation. The instructions for installing the accessory curb are packaged with the curb.

For end-discharge applications place the unit on a level base that provides proper support. On flat roofs, be sure that the unit is located at least 4-ins. above the highest expected water level on the roof to prevent flooding.

B. Ground-Level Installation

Place the unit on a solid, level, concrete pad that is a mini-

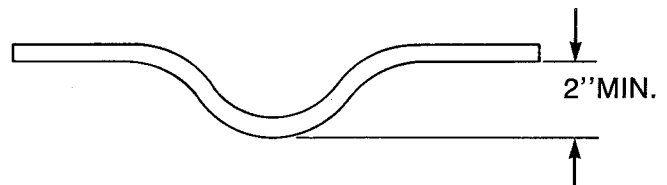

Fig. 5—Condensate Trap

imum of 2-ins. thick and that extends approximately 2-in. beyond the casing on all four sides of the unit. Do not secure the unit to the pad *except* when required by local codes.

C. Clearances

The required minimum operating and service clearances are shown in Figs. 2 and 3. Adequate combustion, ventilation and condenser air must be provided.

▲ CAUTION

Do not restrict condenser airflow. An air restriction at either the outdoor-air inlet (the entire surface of the outdoor coil) or the fan discharge can be detrimental to compressor life.

The condenser fan discharges through the top of the unit. Ensure that the fan discharge does not recirculate to the condenser coil. Do not locate the unit in either a corner or under a complete overhead obstruction. The minimum clearance under a partial overhang (such as a normal house roof overhang) is 48-ins. above unit top. The maximum horizontal extension of a partial overhang must not exceed 48-in.

Do not locate the unit where water, ice, or snow from an overhang or roof will damage or flood the unit by falling on the top. Do not locate the unit where grass, shrubs, or other plants will interfere with the airflow either into or out of the unit. Do not install the unit on carpeting, tile, or other combustible material other than wood flooring. Furnace may be installed on wood flooring or on Class A, B, or C roof covering materials.

Step 2—Condensate Disposal

NOTE: Ensure that condensate-water disposal methods comply with local codes, restrictions, and practices.

Model 48N disposes of condensate water through a 3/4-in., Male Female NPT drain fitting. See Figs. 2 and 3 for location.

Install a 2-in. trap at the drain fitting to ensure proper drainage. See Fig. 5. Make sure that the outlet of the trap is at least 1-in. lower than the unit drain pan connection to prevent the pan from overflowing. Prime the trap with water.

If the installation requires draining the condensate water away from the unit, connect a drain tube using a minimum of 7/8-in. OD copper tubing, 3/4-in. galvanized pipe, or 3/4-in. plastic pipe. *Do not undersize the tube.* Pitch the drain tube downward at a slope of at least 1-in. in every 10-ft of horizontal run. Be sure to check the drain tube for leaks.

Condensate water can be drained directly onto the roof in rooftop installations (where permitted) or onto a gravel apron in ground-level installations. When using a gravel apron, make sure it slopes away from the unit.

Step 3—Venting

The vent-cap assembly is shipped in the burner compartment. Remove the access door to locate the assembly.

Table 1—Maximum Gas Flow Capacity of Pipe in Cubic Feet of Gas Per Hour for Gas Pressures of 0.5 PSIG or Less and a Pressure Drop of 0.5 Inch Water Column (Based on a 0.60 Specific Gravity Gas)

Nominal Iron Pipe, Size, Inches	Internal Diameter, Inches	Length of Pipe, Feet*													
		10	20	30	40	50	60	70	80	90	100	125	150	175	200
1/2	.622	175	120	97	82	73	66	61	57	53	50	44	40	—	—
3/4	.824	360	250	200	170	151	138	125	118	110	103	93	84	77	72
1	1.049	680	465	375	320	285	260	240	220	205	195	175	160	145	135
1-1/4	1.380	1,400	950	770	600	580	530	490	460	430	400	360	325	300	280
1-1/2	1.610	2,100	1,460	1,180	990	900	810	750	690	650	620	550	500	460	430

Ref: Table C-4, NFPA 54—1984

*This length includes an ordinary number of fittings.

CAUTION

The venting system is designed to ensure proper venting. The vent cap assembly must be installed as indicated in this section of the unit Installation Instructions.

NOTE: Screw holes in the flue assembly and the unit flue panel are *not* symmetrically located; thereby, ensuring proper orientation when installing these components.

Refer to Fig. 6 and install the vent cap as follows:

1. Place vent cap assembly over flue panel, orient screw holes in vent cap with holes in flue panel, and secure vent cap in place by inserting the single screw on the right side of vent cap.
2. Place the vent cap guard over the vent cap, orient holes in vent cap guard with holes in vent cap and flue panel. Secure the entire assembly with the remaining two screws on the left side of vent cap and vent cap guard assembly.

Step 4—Gas Piping

The gas supply pipe enters the unit through the access hole provided. The gas connection to the unit is made to the 1/2-in. FPT gas inlet on the manual shutoff or gas valve.

Install a separate gas supply line that runs directly from the meter to the heating section. Refer to Table 1 and the National Fuel Gas Code for gas pipe sizing. *Do not use cast-iron pipe.* Check the local utility for recommendations concerning existing lines. Choose a supply pipe that is large enough to keep the pressure loss as low as practical. *Never use pipe smaller than the 1/2-in. FPT gas inlet on the unit gas valve.*

When installing the gas supply line, observe local codes pertaining to gas pipe installations. Refer to the National Fuel Gas Code ANSI Z223.1-1984 (In Canada, CAN/CGA B149.1, (2)-M86) or NFPA 54-1984 in the absence of local building codes. Adhere to the following pertinent recommendations:

1. Avoid low spots in long runs of pipe. Grade all pipe 1/4-in. in every 15-ft to prevent traps. Grade all horizontal runs downward to risers. Use risers to connect to heating section and to meter.
2. Protect all segments of piping system against physical and thermal damage. Support all piping with appropriate straps, hangers, etc. Use a minimum of one hanger every 6-ft. For pipe sizes larger than 1/2-in., follow recommendations of national codes.
3. Apply joint compound (pipe dope) sparingly and only to male threads of joint when making pipe connections. Use only pipe dope that is resistant to action of liquefied petroleum gases as specified by local and/or national codes. *Never use teflon tape.*

4. Install sediment trap in riser leading to heating section. This drip leg functions as a trap for dirt and condensate. Install trap where condensate can not freeze. Install this sediment trap by connecting a piping tee to riser leading to heating section, so that straight-through section of tee is vertical. See Fig. 7. Then, connect capped nipple into lower end of tee. Extend capped nipple below level of gas controls.
5. Install an accessible, external, manual main shut-off valve in gas supply pipe within 6-ft of heating section.
6. Install ground-joint union close to heating section between unit manual shutoff and external manual main shut-off valve.
7. Pressure-test all gas piping in accordance with local and national plumbing and gas codes before connecting piping to unit.

NOTE: When pressure testing the gas supply system *after* the gas supply piping has been connected to the unit gas valve, the supply piping must be disconnected from the gas valve during any pressure testing of the piping systems at test pressure in excess of 0.5 psig. When pressure testing the gas supply piping system at test pressures equal to or less than 0.5 psig, the unit heating section must be isolated from the gas piping system by closing the external main manual shut-off valve and slightly opening the ground-joint union.

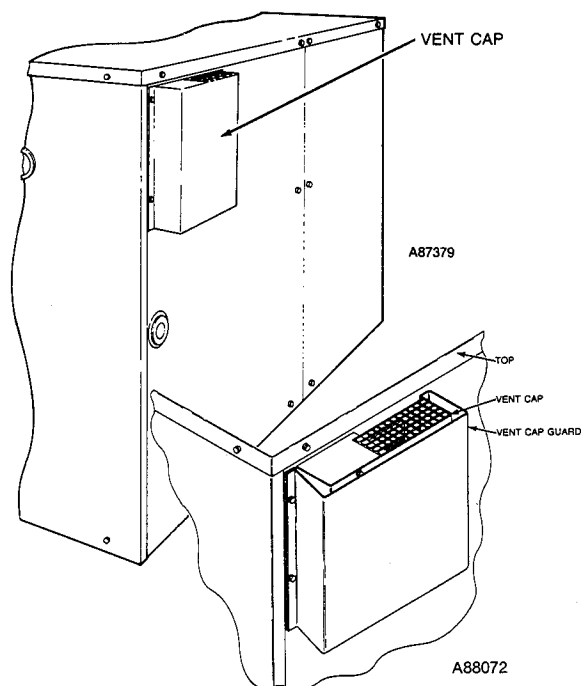
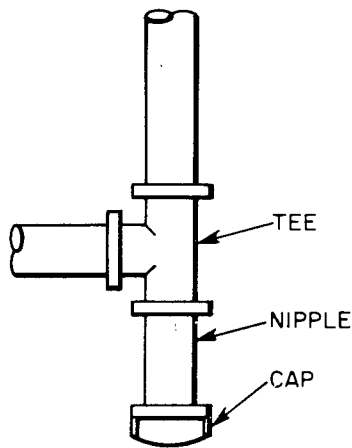

Fig. 6—Vent Cap Assembly



A73130

Fig. 7—Sediment Trap

▲ CAUTION

Unstable operation may occur when the gas valve and manifold assembly are forced out of position while connecting improperly routed rigid gas piping to the gas valve. Use a backup wrench when making connection to avoid strain on, or distortion of, the gas control piping.

▲ CAUTION

If a flexible conductor is required or allowed by the authority having jurisdiction, black iron pipe shall be installed at the gas valve and extend a minimum of 2-ins. outside the unit casing.

▲ WARNING

Never use a match or other open flame when checking for gas leaks. Never purge gas line into combustion chamber. Failure to adhere to this warning could result in an explosion.

8. Check for gas leaks at all field-installed and factory-installed gas lines after all piping connections have been completed. Use soap-and-water solution (or method specified by local codes and/or regulations).

Step 5—Duct Connections

Model 48N has duct flanges on the supply- and return-air openings on the side and bottom of the unit. See Figs. 2 and 3 for connection sizes and locations.

NOTE: The design and installation of the duct system must be in accordance with the standards of the National Fire Protection Association for installation of nonresidence-type air conditioning and ventilating systems, NFPA No. 90A or residence-type, NFPA No. 90B; and/or local codes and ordinances.

Adhere to the following criteria when selecting, sizing, and installing the duct system:

1. Remove appropriate panels from unit to obtain either side or bottom discharge. If models 48NLT018 thru 48NMT042 are installed in horizontal discharge applications, remove side duct covers, save screws, and install the covers on bottom duct openings. For models 48NHT036 thru 48NHT060 remove either side or bottom duct covers as needed and discard.

2. Select and size ductwork, supply-air registers, and return-air grilles according to ASHRAE recommendations.

▲ CAUTION

When the duct-system fastening holes are being drilled into side of Model 48N instead of the unit duct flanges, use extreme care to avoid puncturing the coil or coil tubes.

3. Use flexible transition between rigid ductwork and unit to prevent transmission of vibration. The transition may be screwed or bolted to duct flanges. Use suitable gaskets to ensure weather and airtight seal.
4. Install external, field-supplied air filter(s) in return-air ductwork where it is easily accessible for service. Recommended filter sizes are shown in Tables 2 thru 7.
5. Size all ductwork for maximum required airflow (either heating or cooling) for unit being installed. Avoid abrupt duct size increases or decreases.
6. Adequately insulate and weatherproof all ductwork located outdoors. Insulate ducts passing thru unconditioned space, and use vapor barrier in accordance with latest issue of SMACNA and ACCA minimum installation standards for heating and air conditioning systems. Secure all ducts to building structure.
7. Flash, weatherproof, and vibration-isolate all openings in building structure in accordance with local codes and good building practices.

Step 6—Electrical Connections

▲ WARNING

The unit cabinet must have an uninterrupted, unbroken, electrical ground to minimize the possibility of personal injury if an electrical fault should occur. This ground may consist of electrical wire connected to the unit ground lug in the control compartment, or conduit approved for electrical ground when installed in accordance with the National Electrical Code ANSI/NFPA 70-1987 (in Canada, Canadian Electrical Code CSA C22.1) and local electrical codes. *Do not use gas piping as an electrical ground.* A failure to adhere to this warning could result in the installer being liable for the personal injury of others.

▲ CAUTION

A failure to follow these precautions could result in damage to the unit being installed:

1. Make all electrical connections in accordance with National Electrical Code ANSI/NFPA 70-1987 and local electrical codes governing such wiring. In Canada, all electrical connections must be in accordance with CSA standard C22.1 Canadian Electrical Code Part 1 and applicable local codes. Refer to Unit Wiring Diagram.
2. Use only *copper* conductor for connections between field-supplied electrical disconnect switch and unit. **DO NOT USE ALUMINUM WIRE.**
3. Ensure that high-voltage power to unit is within operating voltage range indicated on unit rating plate. On 3-phase units, ensure that phases are balanced within 2%. Consult local power company for correction of improper voltage and/or phase balance.

Table 2—Specifications—Models 48N (Sizes NLT018300 thru NLT036600)

MODEL	48N	48N	48N	48N	48N	48N	48N	48N	48N
SIZE	LT018300	LT024300	HT024300	LT030300	MT030300	HT030300	LT036300	LT036500	48N
Unit Volts—Phase (60 Hz)	208/230—1	208/230—1	208/230—1	208/230—1	208/230—1	208/230—1	208/230—1	208/230—3	460—3
Operating Voltage Range	187—253	187—253	187—253	187—253	187—253	187—253	187—253	187—253	414—506
Unit Full Load Amps	11.5	14.2	14.2	16.8	16.8	17.3	21.2	14.6	7.7
Maximum Fuse Size (Amps)	20	25	25	30	30	30	40	25	15
Minimum Ampacity for Wire Sizing*	13.6	17.1	17.1	20.4	20.4	20.7	26.9	18.6	9.0
Minimum Wire Size (75 C Copper)	14	12	12	10	10	10	10	12	14
Maximum Wire Length (Ft.)	60	70	70	100	100	100	75	65	110
Cooling Capacity (Btuh)†	17,800	23,800	23,800	29,000	29,000	29,000	35,200	35,200	35,200
Rated Cooling Airflow (cfm)†	600	800	800	1100	1100	1100	1300	1300	1300
External Static Pressure (In. water)†	0.10	0.10	0.10	0.15	0.15	0.15	0.15	0.15	0.15
ARI Sound Rating‡	7.8	8.0	8.0	8.0	8.0	8.0	8.0	8.0	8.0
Rated Heating Input (cfm)	40,000	40,000	60,000	40,000	60,000	80,000	60,000	60,000	60,000
Output Capacity (Btuh)**	31,000	31,000	46,000	31,000	46,000	61,000	46,000	48,000	48,000
AFUE (%)**	77.5	77.5	77.5	77.5	77.5	77.5	77.5	—	—
Rated Heating Airflow (cfm)	658	658	740	658	740	987	987	987	987
Recommended Minimum Field-Supplied Filter Size (Sq In.)††									
Disposable-Type	288	384	384		528			624	
Cleanable- or High-Capacity Type	192	256	256		352			416	

(Applicable notes are listed below Table 4.)

Table 3—Specifications—Models 48N (Sizes MT036300 thru VT036600)

MODEL	48N	48N	48N	48N	48N	48N	48N	48N	48N
SIZE	MT036300	MT036500	MT036600	HT036300	HT036500	HT036600	VT036300	VT036500	VT036600
Unit Volts—Phase (60 Hz)	208/230—1	208/230—3	460—3	208/230—1	208/230—3	460—3	208/230—1	208/230—3	460—3
Operating Voltage Range	187—253	187—253	414—506	187—253	187—253	414—506	187—253	187—253	414—506
Unit Full Load Amps	21.2	14.6	7.7	22.4	16.8	8.5	22.4	16.8	8.5
Maximum Fuse Size (Amps)	40	25	15	40	25	15	40	25	15
Minimum Ampacity for Wire Sizing*	26.9	18.6	9.0	26.2	19.3	9.8	26.2	19.3	9.8
Minimum Wire Size (75 C Copper)	10	12	14	41	12	12	10	10	10
Maximum Wire Length (Ft.)	75	65	110	60	70	70	100	100	100
Cooling Capacity (Btuh)†	35,200	35,200	35,200	35,800	35,800	35,800	35,800	35,800	35,800
Rated Cooling Airflow (cfm)†	1300	1300	1300	1300	1300	1300	1300	1300	1300
External Static Pressure (In. water)†	0.15	0.15	0.15	0.15	0.15	0.15	0.15	0.15	0.15
ARI Sound Rating‡	8.0	8.0	8.0	8.0	8.0	8.0	8.0	8.0	8.0
Rated Heating Input (cfm)	80,000	80,000	80,000	100,000	100,000	100,000	120,000	120,000	120,000
Output Capacity (Btuh)**	61,000	64,000	64,000	78,000	80,000	80,000	93,000	96,000	96,000
AFUE (%)**	77.5	—	—	77.5	—	—	77.5	—	—
Rated Heating Airflow (cfm)	987	987	987	1481	1481	1481	1367	1367	1367
Recommended Minimum Field-Supplied Filter Size (Sq In.)††									
Disposable-Type				624				624	
Cleanable- or High-Capacity Type				416				416	

(Applicable notes are listed below Table 4.)

Table 4—Specifications—Models 48N (Sizes LT042300 thru HT042600)

MODEL	48N	48N	48N	48N	48N	48N	48N	48N	48N
SIZE	LT042300	LT042500	LT042600	MT042300	MT042500	MT042600	HT042300	HT042500	HT042600
Unit Volts—Phase (60 Hz)	208/230—1	208/230—1	460—3	208/230—1	208/230—3	460—3	208/230—1	208/230—3	460—3
Operating Voltage Range	187—253	187—253	414—506	187—253	187—253	414—506	187—253	187—253	414—506
Unit Full Load Amps	24.6	16.0	8.8	24.6	16.0	8.8	26.7	18.2	9.6
Maximum Fuse Size (Amps)	50	30	15	50	30	15	45	30	15
Minimum Ampacity for Wire Sizing*	31.1	20.4	10.3	31.1	2.4	10.3	31.7	21.1	11.1
Minimum Wire Size (75 C Copper)	8	10	14	8	10	14	10	12	14
Maximum Wire Length (Ft.)	95	100	100	95	100	100	75	65	110
Cooling Capacity (Btuh)†	41,500	41,500	41,500	41,500	41,500	41,500	41,500	41,500	41,500
Rated Cooling Airflow (cfm)†	1500	1500	1500	1500	1500	1500	1500	1500	1500
External Static Pressure (In. water)†	0.15	0.15	0.15	0.15	0.15	0.15	0.15	0.15	0.15
ARI Sound Rating‡	7.8	8.0	8.0	8.0	8.0	8.0	8.2	8.2	8.2
Rated Heating Input (cfm)	60,000	60,000	60,000	80,000	80,000	80,000	100,000	100,000	100,000
Output Capacity (Btuh)**	46,000	48,000	48,000	61,000	64,000	64,000	78,000	80,000	80,000
AFUE (%)**	77.5	—	—	77.5	—	—	77.5	—	—
Rated Heating Airflow (cfm)	987	987	987	987	987	987	1481	1481	1481
Recommended Minimum Field-Supplied Filter Size (Sq In.)††									
Disposable-Type				720				720	
Cleanable- or High-Capacity Type				480				480	

*If other than 75 C copper wire is used, determine size from unit ampacity and the National Electrical Code. Voltage drop of wire must be less than 2% of unit rated voltage.

†Rated in accordance with U.S. Government D.O.E. test procedures and/or ARI Standard 210.

‡Rated in accordance with ARI Standard 270.

**The capacity ratings of single-phase units are in accordance with U.S. Government D.O.E. test procedures and/or A.G.A. certification requirements. For 3-phase units, the efficiency rating is a product thermal efficiency rating determined under continuous operating conditions, independent of any installed system.

††Required filter areas shown are based on the larger of the ARI-rated cooling airflow or the heating airflow at a velocity of 300 ft/min for disposable type or 450 ft/min for high-capacity type. Air filter pressure drop must not exceed 0.08 in.-water.

Table 5—Specifications—Models 48N (Sizes VT042300 thru MT048600)

MODEL	48N	48N	48N	48N	48N	48N	48N	48N	48N
SIZE	VT042300	VT042500	VT042600	LT048300	LT048500	LT048600	MT048300	MT048500	MT048600
Unit Volts—Phase (60 Hz)	208/230—1	208/230—3	460—3	208/230—1	208/230—3	460—3	208/230—1	208/230—3	460—3
Operating Voltage Range	187—253	187—253	414—506	187—253	187—253	414—506	187—253	187—253	414—506
Unit Full Load Amps	26.7	18.2	9.6	27.2	22.1	11.0	27.5	22.1	11.0
Maximum Fuse Size (Amps)	45	30	15	50	40	20	50	40	20
Minimum Ampacity for Wire Sizing*	31.7	21.1	11.1	32.7	26.0	13.1	32.7	26.1	13.1
Minimum Wire Size (75 C Copper)	10	12	14	8	10	14	8	10	14
Maximum Wire Length (Ft.)	75	65	110	95	100	100	95	100	100
Cooling Capacity (Btuh)†	41,500	41,500	41,500	47,500	47,500	47,500	47,500	47,500	47,500
Rated Cooling Airflow (cfm)†	1500	1500	1500	1700	1700	1500	1700	1700	1700
External Static Pressure (in. water)†	0.15	0.15	0.15	0.20	0.20	0.15	0.20	0.20	0.20
ARI Sound Rating‡	8.2	8.2	8.2	8.2	8.2	8.2	8.2	8.2	8.2
Rated Heating Input (cfm)	120,000	120,000	120,000	80,000	80,000	60,000	100,000	100,000	100,000
Output Capacity (Btuh)**	93,000	96,000	96,000	62,000	64,000	48,000	78,000	80,000	80,000
AFUE (%)**	77.5	—	—	77.5	—	—	77.5	—	—
Rated Heating Airflow (cfm)	1367	1367	1367	1481	1481	1481	1481	1481	1481
Recommended Minimum Field-Supplied Filter Size (Sq In.)††									
Disposable-Type	720			816			816		
Cleanable- or High-Capacity Type	480			544			544		

(Applicable notes are listed below Table 7.)

Table 6—Specifications—Models 48N (Sizes HT048300 thru MT060600)

MODEL	48N	48N	48N	48N	48N	48N	48N	48N	48N
SIZE	HT048300	HT048500	HT048600	LT060300	LT060500	LT060600	MT060300	MT060500	MT060600
Unit Volts—Phase (60 Hz)	208/230—1	208/230—3	460—3	208/230—1	208/230—3	460—3	208/230—1	208/230—3	460—3
Operating Voltage Range	187—253	187—253	414—506	187—253	187—253	414—506	187—253	187—253	414—506
Unit Full Load Amps	27.5	22.1	11.0	40.8	31.6	14.6	40.8	31.6	14.6
Maximum Fuse Size (Amps)	50	40	20	60	50	25	60	50	25
Minimum Ampacity for Wire Sizing*	32.7	26.0	13.1	48.5	37.0	17.2	48.5	37.0	17.2
Minimum Wire Size (75 C Copper)	10	12	14	8	10	14	8	10	14
Maximum Wire Length (Ft.)	75	65	110	95	100	100	95	100	100
Cooling Capacity (Btuh)†	47,500	47,500	47,500	59,500	59,500	59,500	59,500	59,500	59,500
Rated Cooling Airflow (cfm)†	1700	1700	1700	2000	2000	2000	2000	2000	2000
External Static Pressure (in. water)†	0.20	0.20	0.20	0.20	0.20	0.20	0.20	0.20	0.20
ARI Sound Rating‡	8.2	8.2	8.2	8.4	8.4	8.4	8.4	8.4	8.4
Rated Heating Input (cfm)	120,000	120,000	120,000	80,000	80,000	80,000	100,000	100,000	100,000
Output Capacity (Btuh)**	93,000	96,000	96,000	62,000	64,000	64,000	78,000	80,000	80,000
AFUE (%)**	77.5	—	—	77.5	—	—	77.5	—	—
Rated Heating Airflow (cfm)	1367	1367	1367	1481	1481	1481	1646	1646	1646
Recommended Minimum Field-Supplied Filter Size (Sq In.)††									
Disposable-Type	816			960			960		
Cleanable- or High-Capacity Type	544			640			640		

(Applicable notes are listed below Table 7.)

Table 7—Specifications—Models 48N (Sizes HT060300 thru HT060600)

MODEL	48N	48N	48N
SIZE	HT060300	HT060500	HT060600
Unit Volts—Phase (60 Hz)	208/230—1	208/230—3	460—3
Operating Voltage Range	187—253	187—253	414—506
Unit Full Load Amps	40.8	31.6	14.6
Maximum Fuse Size (Amps)	60	50	25
Minimum Ampacity for wire Sizing*	48.5	37.0	17.2
Minimum Wire Size (75 C Copper)	10	12	14
Maximum Wire Length (Ft.)	75	65	110
Cooling Capacity (Btuh)†	59,500	59,500	59,500
Rated Cooling Airflow (cfm)†	2000	2000	2000
External Static Pressure (in. water)†	0.20	0.20	0.20
ARI Sound Rating‡	8.4	8.4	8.4
Rated Heating Input (Btuh)**	120,000	120,000	120,000
Output Capacity (Btuh)**	93,000	96,000	96,000
AFUE (%)**	77.5	—	—
Rated Heating Airflow (cfm)	1975	1975	1975
Recommended Minimum Field-Supplied Filter Size††			
Disposable-Type	960		
Cleanable- or High-Capacity Type	640		

*If other than 75 C copper wire is used, determine size from unit ampacity and the National Electrical Code. Voltage drop of wire must be less than 2% of unit rated voltage.

†Rated in accordance with U.S. Government D.O.E. test procedures and/or ARI Standard 210.

‡Rated in accordance with ARI Standard 270.

**The capacity ratings of single-phase units are in accordance with U.S. Government D.O.E. test procedures and/or A.G.A. certification requirements. For 3-phase units, the efficiency rating is a product thermal efficiency rating determined under continuous operating conditions, independent of any installed system.

††Required filter areas shown are based on the larger of the ARI-rated cooling airflow or the heating airflow at a velocity of 300 ft/min for disposable type or 450 ft/min for high-capacity type. Air filter pressure drop must not exceed 0.08 in.-water.

4. Insulate low-voltage wires for highest voltage contained within conduit when low-voltage control wires are run in same conduit as high-voltage wires.
5. Do not damage internal components when drilling thru any panel to mount electrical hardware, conduit, etc.

A. High-Voltage Connections

The unit must have a separate electrical service with a field-supplied, waterproof, fused disconnect switch mounted at, or within sight from the unit. Refer to the unit rating plate for maximum fuse size and minimum circuit amps (ampacity) for wire sizing. Tables 2 thru 7 show recommended wire sizes based on rating plate data.

The field-supplied disconnect switch box may be mounted on the unit over the high-voltage inlet hole in the control corner panel. See Figs. 2 and 3.

Proceed as follows to complete the high-voltage connections to the unit:

1. Connect ground lead to chassis ground connection when using separate ground wire.
2. Run high-voltage leads into unit control box and connect to contactor. See unit wiring label, and Fig. 8.

B. Special Procedures for 208-V Operation

⚠ WARNING

Make sure that the power supply to the unit is switched OFF before making any wiring changes. Electrical shock can cause personal injury or death.

For operation on 208 volts, disconnect the orange transformer-primary lead from the contactor. See the unit wiring label. Remove the tape and cover from the terminal on the end of the red transformer-primary lead. Save the cover. Connect the red lead to the contactor terminal from which the orange lead was disconnected.

Using the cover removed from the red lead, insulate the loose terminal on the orange lead. Wrap the cover with electrical tape so that the metal terminal can not be seen.

Indoor blower motor speed taps should be changed for 208V operation on 208/230v rated units. Interchange motor leads at printed circuit board (PCI) in unit control box. High speed for cooling and medium speed for heating operation. See Step 9-C and unit wiring label. Do not change blower speed setting for 460V rated units.

C. Control Voltage Connections

Locate the room thermostat on an inside wall in the space to be conditioned where it will not be subjected to either a cooling or heating source or direct exposure to sunlight. Mount the thermostat 4 to 5-ft above the floor.

Use No. 18 AWG color-coded, insulated (35 C minimum) wires to make the control voltage connections between the thermostat and the unit. If the thermostat is located more than 100-ft from the unit (as measured along the control voltage wires), use No. 16 AWG color-coded, insulated (35 C minimum) wires.

A grommeted, control voltage inlet hole is located in the panel adjacent to the control access panel. See Figs. 2 and 3. Run the low-voltage leads from the thermostat, thru the inlet hole, and to the control voltage terminals through a hole in the bottom of the unit control box. Pass control voltage leads through wire ties located under unit control box. Connect the thermostat leads to the terminals as shown in Fig. 8.

D. Heat Anticipator Setting

The room thermostat heat anticipator must be properly

adjusted to ensure proper heating performance. Set the heat anticipator, using an ammeter to determine the exact required setting.

NOTE: For thermostat selection purposes, use 1.0 amp for the approximate required setting.

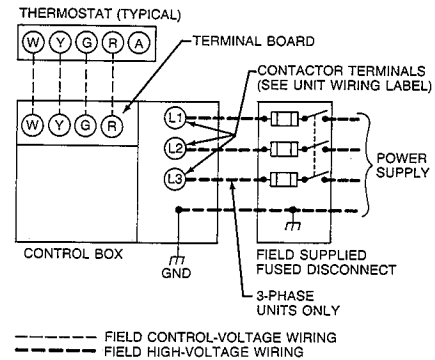

A87380

Fig. 8—High and Control Voltage Connections

Failure to make a proper heat anticipator adjustment will result in improper operation, discomfort to the occupants of the conditioned space, and inefficient energy utilization; however, the required setting may be changed slightly to provide a greater degree of comfort for a particular installation.

E. Circuit Breaker

Unit has manual reset circuit breaker which is located in the low voltage wiring box adjacent to low voltage terminal board. If unit fails to operate, first check breaker for tripped position. If breaker is tripped, re-set and try to start unit. If breaker continues to trip there is a problem in the low voltage electrical circuit. (Electrical short, ground, or transformer overload) Correct the condition and check for normal unit operation.

Step 7—Preparing Unit for Startup

⚠ WARNING

DANGER: Failure to observe the following warnings could result in serious personal injury:

1. Follow recognized safety practices and wear protective goggles when checking or servicing refrigerant system.
2. Do not operate compressor or provide any electric power to unit unless compressor terminal cover is in place and secured.
3. Do not remove compressor terminal cover until all electrical sources have been disconnected.
4. Relieve all pressure from system before touching or disturbing anything inside terminal box if refrigerant leak is suspected around compressor terminals.
5. Never attempt to repair soldered connection while refrigerant system is under pressure.
6. Do not use torch to remove any component. System contains oil and refrigerant under pressure. To remove a component, wear protective goggles and proceed as follows:
 - a. Shut off gas supply and *then* electrical power to unit.
 - b. Relieve all pressure from system.
 - c. Cut component connecting tubing with tubing cutter and remove component from unit.
 - d. Carefully unsweat remaining tubing stubs when necessary. Oil can ignite when exposed to torch flame.

A. Prestartup Procedures

Proceed as follows to inspect and prepare the unit for initial startup:

1. Remove all access panels.
2. Read and follow instructions on all WARNING, CAUTION, and INFORMATION labels attached to, or shipped with unit.
3. Make the following inspections:
 - a. Inspect for shipping and handling damages such as broken lines, loose parts, disconnected wires, etc.
 - b. Inspect for oil at all refrigerant tubing connections and on unit base. Detecting oil generally indicates a refrigerant leak. Leak-test all refrigerant tubing connections using electronic leak detector, halide torch, or liquid-soap solution. If refrigerant leak is detected, see "Refrigerant Leaks" in the next part of this section.
 - c. Inspect all field- and factory-wiring connections. Be sure that connections are completed and tight.
 - d. Inspect coil fins. If damaged during shipping and handling, carefully straighten fins with a fin comb.
4. Verify the following conditions:

▲ WARNING

Do not purge gas supply into the combustion chamber. Do not use a match or other open flame to check for gas leaks. Failure to adhere to this warning could result in an explosion.

- a. Make sure that gas supply has been purged, and that all gas piping has been checked for leaks.
- b. Make sure that outdoor fan blade is correctly positioned in fan orifice. *Blades should clear fan motor by no more than 1/4-in.*
- c. Make sure that air filter(s) is in place.
- d. Make sure that condensate drain pan is filled with water to ensure proper drainage.
- e. Make sure that all tools and miscellaneous loose parts have been removed.

Unit is now ready for initial startup.

B. Refrigerant Leaks

Proceed as follows to repair a refrigerant leak and to charge the unit:

1. Locate leak and ensure that refrigerant system pressure has been relieved.
2. Repair leak following accepted practices.

NOTE: Install a filter-drier whenever the system has been opened for repair.

3. Add a small charge of R-22 refrigerant vapor to system and leak-test unit.
4. Evacuate refrigerant system if additional leaks are not found.
5. Charge unit with R-22 refrigerant, using a volumetric-charging cylinder or accurate scale. *Refer to unit rating plate for required charge.* Be sure to add extra refrigerant to compensate for internal volume of filter-drier.

NOTE: See Step 9, part B for checking and adjusting refrigerant charge.

Step 8—Heating Section Startup and Adjustments

▲ CAUTION

Complete the required procedures given in Step 7, "Preparing Unit for Startup," before starting the unit.

Do not jumper any safety devices when operating the unit.

Ensure that burner orifices are properly aligned. Unstable operation may occur when the burner orifices in the manifold are misaligned.

NOTE: When installing a unit in extremely cold climate areas, a run-in period for the inducer motor is recommended. After the unit has been installed disconnect the red wire from terminal 2 at the ignition control (IGN) and jumper terminals R-W at the control voltage terminal board. See Figs. 12, 13, & 14. The inducer motor should run but burner ignition will not occur. Allow inducer motor to run for 4 to 5 hours. Reconnect red wire to terminal 2 at ignition control (IGN) and remove R-W jumper at the control voltage terminal board. Proceed as follows to complete heating section start up.

Follow the lighting instructions on the heating section operation label (located inside the burner access door) to start the heating section.

However, when lighting the unit for the first time, perform the following additional steps:

1. If the gas supply pipe was not purged before connecting the unit, it will be full of air. It is recommended that the ground joint union be loosened, and the supply line be allowed to purge until the odor of gas is detected. Never purge gas lines into a combustion chamber. Immediately upon detection of gas odor, retighten the union. Allow 5 minutes to elapse, then light unit in accordance with Step 8, part A below.

A. Checking Heating Control Operation

Start and check the unit for proper heating control operation as follows: (See furnace lighting instructions located inside burner access panel.)

Place the room thermostat SYSTEM switch in the HEAT position and the FAN switch in the AUTO position. Set the heating temperature control of the thermostat above room temperature. Observe that after built-in time delays, the pilot automatically lights, the burners light, and the blower motor starts. Observe that the burners and pilot go out, and that after a built-in delay the blower motor stops when the heating control setting of the thermostat is satisfied.

NOTE: 060 size 460V models are equipped with a 3-phase blower motor. Check blower wheel for correct rotation as indicated by arrow on blower housing. If blower wheel rotates in opposite direction, reverse any two blower motor leads or any two line voltage leads. Recheck blower wheel rotation if necessary to reverse leads.

B. Gas Input

Check gas input and manifold pressure after unit start-up. (See Table 8) If adjustment is required proceed as follows.

▲ CAUTION

These units are designed to consume the rated gas inputs using the fixed orifices at specified manifold pressures as shown in Table 8. **DO NOT REDRILL THE ORIFICES UNDER ANY CIRCUMSTANCES.**

The rated gas inputs shown in Table 8 are for altitudes from sea level up to 2000-ft above sea level. These inputs are based on natural gas with a heating value of 1050 Btu/ft³ at 0.65 specific gravity, or LP (propane) gas with a heating value of 2500 Btu/ft³ at 1.5 specific gravity. For elevations above 2000-ft, reduce input 4% for each 1000-ft above sea level. When the gas supply being used has a different heating value or specific gravity, refer to national and local

codes, or contact your Distributor or Branch to determine the required orifice size.

C. Adjusting Gas Input

The gas input to the unit is determined by measuring the gas flow at the meter or by measuring the manifold pressure. Measuring the gas flow at the meter is recommended for natural gas units. The manifold pressure must be measured to determine the input of propane gas units.

1. Measuring Gas Flow at Meter Method—Natural Gas Units

Minor adjustment can be made by changing the manifold pressure. The manifold pressure must be maintained between 3.2 and 3.8-in. water. If larger adjustments are required, change main burner orifices following the recommendations of national and local codes.

NOTE: All other appliances that use the same meter must be turned off when gas flow is measured at the meter.

Proceed as follows:

- a. Turn off gas supply to unit.
- b. Remove pipe plug on outlet of gas valve, then connect manometer at this point. Turn on gas to unit.
- c. Record number of seconds for gas meter test dial to make one revolution.
- d. Divide number of seconds in step c into 3600 (number of seconds in 1 hour).
- e. Multiply result of step d by the number of cubic ft shown for one revolution of test dial to obtain cubic ft of gas flow per hour.
- f. Multiply result of step e by Btu heating value of gas to obtain total measured input in Btuh. Compare this value with heating input shown in Table 8. (Consult the local gas supplier if the heating value of gas is not known.)

Example: Assume that the size of test dial is 1 cubic ft, one revolution takes 30 seconds, and the heating value of the gas is 1050 Btu/ft³, then proceed as follows:

- a. 30 seconds to complete one revolution.
- b. $3600 \div 30 = 120$.
- c. $120 \times 1 = 120 \text{ ft}^3$ of gas flow/hr.
- d. $120 \times 1050 = 126,000$ -Btuh input.

If the desired gas input is 125,000 Btuh, only a minor change in the manifold pressure is required.

Observe manifold pressure and proceed as follows to adjust gas input:

- a. Remove cover screw over regulator adjustment screw on gas valve.
- b. Turn regulator adjustment screw clockwise to increase gas input, or turn regulator adjustment screw counterclockwise to decrease input. Manifold pressure must be between 3.2 and 3.8-in.-water.

⚠ WARNING

Unsafe operation of the unit may result if manifold pressure is outside this range. Personal injury or unit damage may result.

- c. Replace cover screw cap on gas valve.
- d. Turn off gas supply to unit. Remove manometer from pressure tap. Replace pipe plug on gas valve. Turn on gas to unit. Check for leaks.

2. Measuring Manifold Pressure—Propane Gas Units

The main burner orifices on a propane gas unit are sized for the unit rated input when the manifold pressure is 10.5-in. water.

Proceed as follows to adjust gas input on a propane gas unit:

- a. Turn off gas to unit.
- b. Remove pipe plug on outlet of gas valve then connect manometer at this point.
- c. Turn on gas to unit.
- d. Remove cover screw over REG ADJ screw on gas valve.
- e. Adjust regulator adjustment screw for a manifold pressure reading of 10.5-in.-water. Turn adjusting screw clockwise to increase manifold pressure, or turn adjusting screw counterclockwise to decrease manifold pressure.
- f. Replace cover screw.
- g. Turn off gas to unit. Remove manometer from pressure tap. Replace pipe plug on gas valve, then turn on gas to unit. Check for leaks.

D. Check Burner Flame

Observe the unit heating operation, and watch the burner flames through the observation port to see if they are light blue and soft in appearance, and the flames are approximately the same for each burner. See Fig. 10.

E. Blower Heat-Relay Operation

Blower relay PC1 (See the unit wiring diagram.) is located in the control box and adjusts to permit either longer or shorter "off" cycles. The "on" cycle is factory set for 1 minute on timing. The adjusting dial on the relay (See Fig. 9) is factory-set at the minimum position to provide optimum performance for most installations. On unusual installations, the length of time the blower remains on may require increasing. To increase blower operation time, rotate the adjusting dial counter-clockwise. To decrease blower operation time, rotate dial clockwise. (Minimum time 1 minute.) Maximum time 3 minutes.)

F. Airflow and Temperature Rise

The heating section of each size of unit is designed and approved for heating operation within the temperature rise range stamped on the unit rating plate.

Table 8—Rated Gas Inputs at Indicated Manifold Pressures

Model No.	Number of Orifices	Gas Supply Pressure (in. wc)				Manifold Pressure (In. wc)		Natural Gas		Propane Gas†	
		Natural		Propane		Natural	Propane	Orifice P/N	Heating Input (Btuh)*	Input P/N	Heating (Btuh)*
		Min	Max	Min	Max						
48NLT018, 024, 030	2	5.0	13.6	11.0	13.0	3.5	10.5	55365-44	40,000	55365-55	40,000
48NHT024, MT030, LT036, LT042	3	5.0	13.6	11.0	13.0	3.5	10.5	55365-44	60,000	55365-55	60,000
48NHT030, MT036, MT042, LT048, LT060	4	5.0	13.6	11.0	13.0	3.5	10.5	55365-44	80,000	55365-55	80,000
48NHT036, HT042, MT048, MT060	5	5.0	13.6	11.0	13.6	3.5	12.5	55365-44	100,000	55365-55	100,000
48NVT036, VT042, HT048, HT060	6	5.0	13.6	11.0	13.6	3.5	10.5	55365-44	120,000	55365-55	120,000

*Based on altitudes from sea level up to 2000 feet above sea level. For altitudes above 2000 feet, reduce input rating 4% for each 1000 feet above sea level. In Canada, from 2000 ft. above sea level to 4,500 ft. above sea level, derate the unit 10%.

†When a 48N is converted to propane, the burners must be modified. See kit instructions.

Table 9 shows the approved temperature rise range for each unit, and the air delivery Cfm at various temperature rises. The heating operation airflow must produce a temperature rise that falls within the approved range.

Refer to Step 9, part C, of these instructions to adjust heating airflow, when required.

G. Safety Check of Limit Control

The control shuts off the combustion gas supply and energizes the circulating-air blower motor if the furnace overheats.

The recommended method of checking this limit control is to gradually block off the return air after the furnace has been operating for a period of at least 5 minutes. As soon as the limit control functions, the return-air opening should be unblocked to permit normal air circulation. By using this method to check the limit control, it can be established that the limit is functioning properly and the furnace will "fail-safe" if there is a restricted circulating air supply or motor failure. If the limit control does not function during this test, the cause must be determined and corrected.

H. Heating Sequence of Operation See Figs. 12, 13 or 14

Room thermostat calls for heat closing circuit between "R" and "W" 24 volt control circuit terminals. (Power to the "R" terminal is supplied through "CB" Circuit Breaker and "LS, ALS and FL" safety switches) "PC2" inducer control board is energized which starts the inducer motor "IM". The inducer motor comes up to speed, the vacuum in the collector box increases, opening the normally closed and closing the normally open contacts of the contacts of the pressure switch "PS" energizing the circuit to the "IGN" ignition control and the pilot valve "PV". If the flame sensor proves the presence of the pilot flame the internal switching of the ignition control de-energizes the spark generator and energizes the main gas valve, "MV" and the "IFR2" electronic timer. Gas flows to the main burners and is ignited by the pilot flame. The "PC1" electronic timer will close the "IFR2" relay between 60 to 90 seconds after the burners are ignited and the blower motor "IFM" will start. When the thermostat is satisfied the "R" and "W" circuit is opened and power is removed from the "PC2" inducer control and the "IGN" ignition module which causes the main gas valve to close instantly and the inducer motor is de-energized. The electronic timer "PC1" will keep the "IFM" blower motor running an additional 1 to 3 minutes. Then the blower stops and the unit is on standby until another call for heat.

NOTE: If the main limit switch opens due to the unit overheating, the blower motor is turned on thru the electronic board.

If the pilot fails to light within a 50 second trail for ignition period from the initial call for heat the ignition control "IGN" will lockout the system and prevent further lighting attempts. To reset, open the "R" - "W" thermostat circuit for 30 seconds and re-close.

I. Limit Switches

Furnace limit switch "LS" (See Figs. 12, 13 or 14.) closes the gas valve if the leaving-air temperature exceeds the maximum allowable temperature.

Normally closed limit switch "LS" completes the control circuit through the thermostat "R" circuit. See Figs. 12, 13 or 14. Should the leaving-air temperature rise above the maximum allowable temperature the limit switch opens and the "R" control circuit "breaks." Any interruption in the "R" control circuit instantly closes the gas valve and stops gas flow to the burners and pilot. The blower motor contin-

ues to run until the time-delay sequence of blower relay "PC1" is completed.

When the air temperature at the limit switch drops to the low-temperature setting of the limit switch, the switch closes and completes the "R" control circuit. The electric-spark ignition system cycles and the unit returns to normal heating operation.

J. Auxiliary Limit Switch

Auxiliary limit switch "ALS" is a temperature-actuated manual reset switch and is connected in series with the limit switch "LS." The function of the switch is to prevent abnormal blower compartment temperatures. The switch is mounted on the blower housing. When the temperature at the auxiliary switch reaches the maximum allowable temperature the "R" control circuit "breaks", closing the gas valve and stopping gas flow to the burners and pilot. To reset switch push in on red push button. If it cycles again, shut down the unit and call for service.

K. Fusible Link

Fusible Link "FL" is a temperature-actuated device connected in series with the limit switch "LS." It is located in the wire bundle adjacent to the burner manifold.

The function of the device is to prevent abnormally high burner compartment temperatures. The link will melt if an overheating condition caused by inadequate combustion air supply or improper venting occurs. Do not jumper this fuse. Correct the condition and replace the fuse with an identical part.

Step 9—Cooling Section Startup and Adjustments

▲ CAUTION

Complete the required procedures given in Step 7, "Preparing Unit for Startup," before starting the unit.

Do not jumper any safety devices when operating the unit.

Do not operate the compressor when the outdoor temperature is below 55 F (unless accessory low-temp kit is installed).

Do not rapid-cycle the compressor. Allow 5 minutes between "on" cycles to prevent compressor damage.

A. Checking Cooling Control Operation

Start and check the unit for proper cooling control operation as follows:

1. Place room thermostat SYSTEM switch in OFF position. Observe that blower motor starts when FAN switch is placed in ON position and shuts down when FAN switch is placed in AUTO position.
2. Place SYSTEM switch in COOL position and FAN switch in AUTO position. Set cooling control below room temperature. Observe that compressor, condenser fan, and evaporator blower motors start. Observe that cooling cycle shuts down when control setting is satisfied. Blower motor has off delay of approximately one minute on shut down.
3. When using an autochangeover room thermostat, place both SYSTEM and FAN switches in AUTO positions. Observe that unit operates in heating mode when temperature control is set to "call for heating" (above room temperature) and operates in cooling mode when temperature control is set to "call for cooling" (below room temperature).

NOTE: 060 size 460V models are equipped with a 3-phase

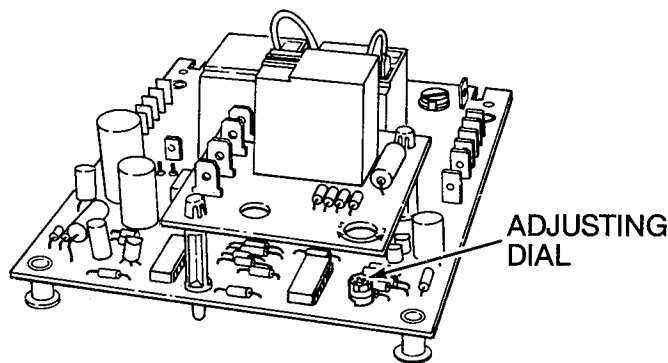

Fig. 9—Blower Heat-Relay

blower motor. Check blower wheel for correct rotation as indicated by arrow on blower housing. If blower wheel rotates in opposite direction, reverse any two blower motor leads or any two line voltage leads. Recheck blower wheel rotation if necessary to reverse leads.

B. Checking and Adjusting Refrigerant Charge

The refrigerant system is fully charged with R-22 refrigerant, tested, and factory-sealed.

NOTE: Adjustment of the refrigerant charge is not required unless the unit is suspected of not having the proper R-22 charge. For all applications, the correct R-22 charge for the best performance is the charge that results in a suction gas superheat of 5 F at the compressor inlet when the unit is operating at the ARI rating conditions of 95 F DB outdoor and 80 F DB/67 F WB indoor.

A superheat charging label is attached to the outside of the compressor access door. The label includes a "Field Superheat Charging Table" and a "Required Suction-Tube (F)" temperature chart.

An accurate superheat thermocouple, or thermistor-type thermometer, a sling psychrometer, and a gauge manifold are required when using the superheat charging method for evaluating the unit charge. *Do not use mercury or small dial-type thermometers because they are not adequate for this type of measurement.*

▲ CAUTION

When evaluating the refrigerant charge, an indicated adjustment to the specified factory charge must always be very minimal. If a substantial adjustment is indicated, an abnormal condition exists somewhere in the cooling system; such as insufficient airflow across either coil or both coils.

Proceed as follows:

1. Remove caps from low- and high-pressure service fittings.
2. Using hoses with valve core depressors, attach low- and high-pressure gauge hoses to low- and high-pressure service fittings, respectively.
3. Start unit in cooling mode and let unit run until system pressures stabilize.
4. Measure and record the following:
 - a. Outdoor ambient-air temperature (F DB).
 - b. Evaporator inlet-air temperature (F WB).
 - c. Suction-tube temperature (F) at low-side service fitting.
 - d. Suction (low-side) pressure (PSIG).
5. Using "Field Superheat Charging Table," compare

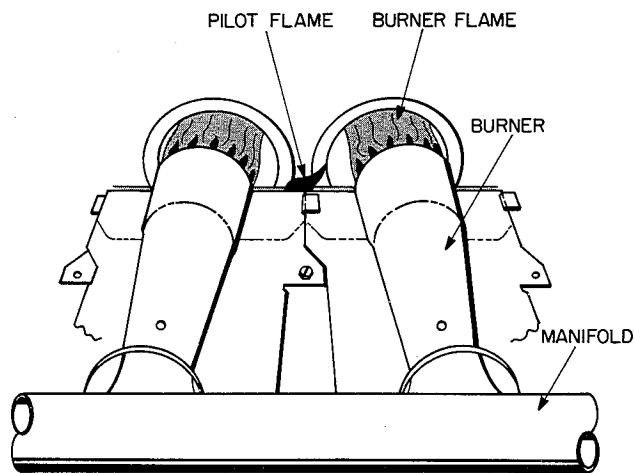

Fig. 10—Monoport Burners

A84076

outdoor-air temperature (F DB) with evaporator inlet-air temperature (F WB) to determine desired system operating superheat temperature. See Table 10.

6. Next, using "Required Suction-Tube (F)" table, compare desired superheat temperature with suction (low-side) operating pressure (PSIG) to determine proper suction-tube temperature. See Table 11.
7. Compare actual suction-tube temperature with proper suction-tube temperature. Using a tolerance of ± 3 F, add refrigerant if actual temperature is more than 3 F higher than proper suction-tube temperature, or remove refrigerant if actual temperature is more than 3 F lower than required suction-tube temperature.

NOTE: If the problem causing the inaccurate readings is a refrigerant leak, see Step 7, part B, of these instructions.

C. Indoor Airflow and Airflow Adjustments

▲ CAUTION

For cooling operation, the recommended airflow is 350 to 450 Cfm per each 12,000 Btuh of rated cooling capacity. For heating operation, the airflow must produce a temperature rise that falls within the range stamped on the unit rating plate.

Model 018-048 size units have direct-drive blower motors. Blower motors are factory-connected to deliver the proper heating and cooling airflows at normal external static pressures (medium speed cooling, low speed heating for 230v units and high speed cooling, heating for 460v units).

060 size units have belt drive blower motors which have the motor pulley factory set at four turns open.

For 208v operation on 208/230v rated direct drive units, interchange motor leads to high speed for cooling and medium speed for heating operation.

Table 9 shows the temperature rise at various airflow rates. Tables 12 and 13 show both heating and cooling airflows at various external static pressures. Refer to these tables to determine the airflow for the system being installed. See Tables 2 thru 7 for the rated heating and cooling airflows.

NOTE: Be sure that all supply- and return-air grilles are open, free from obstructions, and adjusted properly.

▲ WARNING

Disconnect electrical power to the unit before changing blower speed. (Be sure to turn off gas supply before disconnecting electrical power.) Electrical shock can cause personal injury or death.

▲ CAUTION

Do not change the blower-motor lead connections on 460-V units from the factory setting. Damage to unit may result.

The heating and/or cooling airflow of 208/230-V direct-drive blower motors can be changed by changing the lead connections of the blower motor. The motor leads are color-coded as follows:

black = high speed
blue = medium speed
red = low speed

NOTE: For all 208/230 V direct-drive units, the motor lead connected to the heat relay (L) on PC1 blower control determines the heating speed and resulting air-flow; and the motor lead connected to the cooling relay (H) on PC1 blower control determines the cooling speed and resulting airflow. See the unit wiring label.

To change the heating and/or cooling speed of a direct-drive motor, connect the appropriate color-coded lead to the appropriate relay. Connect unused motor lead to terminal M1 on the PC1 blower control.

When installing a 208- or 230-V direct-drive unit that is factory-connected for heating and cooling speeds that are not the same, and the same speed for both heating and cooling is required for a particular application, connect the appropriate color-coded lead to terminal H of cooling relay and connect a field-supplied jumper between terminal L on heat relay and terminal H of cooling relay. Connect unused leads to terminals M1 and M2 on PC1 blower control.

D. Unit Controls

All compressors have the following internal-protection controls:

1. **High-pressure Relief Valve**—This valve opens when the pressure differential between the low and high side becomes excessive.
2. **Compressor Overload**—This overload interrupts power to the compressor when either the current or internal temperature become excessive, and automatically resets when the internal temperature drops to a safe level. This overload may require up to 60 minutes (or longer) to reset; therefore, if the internal overload is suspected of being open, disconnect the electrical power to the unit and check the circuit thru the overload with an ohmmeter or continuity tester.

E. Cooling Sequence of Operation

NOTE: Although the actual unit wiring may vary slightly from that shown in Figs. 12, 13 or 14, the sequence of operation will not be affected.

With the room thermostat SYSTEM switch in the COOL position and the FAN switch in the AUTO position, the cooling sequence of operation is as follows:

When the room temperature rises to a point that is slightly above the cooling control setting of the thermostat, the thermostat completes the circuit between thermostat terminal "R" to terminals "Y" and "G." These completed circuits through the thermostat connect contactor coil "C" (through unit wire "Y") and relay coil "IFR1" (through unit wire "G") across the 24-volt secondary of transformer "TRAN."

The normally open contacts of energized contactor "C" close and complete the circuit through compressor motor "COMP" and condenser fan motor "OFM." Both motors start instantly.

The set of normally open contacts of energized relay "IFR1" closes and completes the circuit through evaporator blower motor "IFM." The blower motor starts instantly.

NOTE: The cooling cycle remains "on" until the room temperature drops to point that is slightly below the cooling control setting of the room thermostat. At this point, the thermostat "breaks" the circuit between thermostat terminal "R" to terminals "Y" and "G." These open circuits deenergize contactor coil "C" and relay coil "IFR1". The condenser and compressor motors stop. After a one minute delay the blower motor stops. The unit is in a "standby" condition, waiting for the next "call for cooling" from the room thermostat.

Step 10—Care and Maintenance

To ensure continuing high performance, and to minimize the possibility of premature equipment failure, periodic maintenance must be performed on this equipment. This combination heating/cooling unit should be inspected at least once each year by a qualified service person.

NOTE TO EQUIPMENT OWNER: Consult your local Dealer about the availability of a maintenance contract.

▲ WARNING

The ability to properly perform maintenance on this equipment requires certain expertise, mechanical skills, tools, and equipment. If you do not possess these, do not attempt to perform any maintenance on this equipment other than those procedures recommended in the Users Manual. A FAILURE TO HEED THIS WARNING COULD RESULT IN SERIOUS PERSONAL INJURY AND POSSIBLE DAMAGE TO THIS EQUIPMENT.

The minimum maintenance requirements for this equipment are as follows:

1. Inspect air filter(s) each month. Clean or replace when necessary.
2. Inspect cooling coil, drain pan, and condensate drain each cooling season for cleanliness. Clean when necessary.
3. Inspect blower motor and wheel for cleanliness and check lubrication each heating and cooling season. Clean and lubricate when necessary.
4. Check electrical connections for tightness and controls for proper operation each heating and cooling season. Service when necessary.
5. Check and inspect heating section before each heating season. Clean and adjust when necessary.
6. Check and clean vent screen if needed.

▲ WARNING

A failure to follow these warnings could result in serious personal injury:

1. Turn off gas supply, *then* turn off electrical power to the unit before performing any maintenance or service on the unit.
2. Use extreme caution when removing panels and parts. As with any mechanical equipment, personal injury can result from sharp edges, etc.
3. Never place anything combustible either on, or in contact with, the unit.
4. Should overheating occur, or the gas supply fail to shut off, shut off the external main manual gas valve to the unit, *then* shut off the electrical supply.

Table 9—Air Delivery (Cfm) at Indicated Temperature Rise and Rated Heating Input

Nominal Size	Heating Input (Btuh)	25	30	35	40	45	50	55	60	65	70	75	80
48NLT018 48NLT024 48NLT030	40,000	—	987	846	740	658	592	538	493	—	—	—	—
48NHT024 48NMT030	60,000	—	—	—	—	987	888	808	740	683	634	592	—
48NLT036 48NLT042	60,000	—	1481	1269	1111	987	888	808	740	—	—	—	—
48NHT030 48NMT036 48NMT042	80,000	—	—	—	—	1316	1185	1077	987	911	846	790	—
48NLT048 48NLT060	80,000	2370	1975	1693	1481	1316	1185	1077	—	—	—	—	—
48NHT036 48NHT042 48NMT048	100,000	—	—	2116	1851	1646	1481	1346	1234	1139	—	—	—
48NMT060	100,000	—	2469	2116	1851	1646	1481	1346	1234	—	—	—	—
48NVT036 48NHT042 48NHT048	120,000	—	—	—	—	—	1777	1616	1481	1367	1269	1185	1111
48NHT060	120,000	—	2962	2539	2222	1975	1777	1616	1481	—	—	—	—

NOTE: Dashed areas of the table do not fall in the approved temperature rise range of the unit.

**Table 10—Superheat Charging Table
(Superheat Entering Suction Service Valve)**

Outdoor Temp (F)	Indoor Coil Entering Air Temp (F WB)													
	50	52	54	56	58	60	62	64	66	68	70	72	74	76
55	9	12	14	17	20	23	26	29	32	35	37	40	42	45
60	7	10	12	15	18	21	24	27	30	33	35	38	40	43
65	—	6	10	13	16	19	21	24	27	30	33	36	38	41
70	—	—	7	10	13	16	19	21	24	27	30	33	36	39
75	—	—	—	6	9	12	15	18	21	24	28	31	34	37
80	—	—	—	—	5	8	12	15	18	21	25	28	31	35
85	—	—	—	—	—	—	8	11	15	19	22	26	30	33
90	—	—	—	—	—	—	5	9	13	16	210	24	27	31
95	—	—	—	—	—	—	—	6	10	14	18	22	25	29
100	—	—	—	—	—	—	—	—	8	12	15	20	23	27
105	—	—	—	—	—	—	—	—	5	9	13	17	22	26
110	—	—	—	—	—	—	—	—	—	6	11	15	20	25
115	—	—	—	—	—	—	—	—	—	—	8	14	18	23

NOTE: Do not attempt to charge system under these conditions or refrigerant slugging may occur.

**Table 11—Required Suction-Tube Temperature (F)
(Entering Suction Service Valve)**

Superheat Temp (F)	Suction Pressure At Service Port (Psig)									
	61.5	64.2	67.1	70.0	73.0	76.0	79.2	82.4	85.7	
0	35	37	39	41	43	45	47	49	51	51
2	37	39	41	43	45	47	49	51	53	53
4	39	41	43	45	47	49	51	53	55	55
6	41	43	45	47	49	51	53	55	57	57
8	43	45	47	49	51	53	55	57	59	59
10	45	47	49	51	53	55	57	59	61	61
12	47	49	51	53	55	57	59	61	63	63
14	49	51	53	55	57	59	61	63	65	65
16	51	53	55	57	59	61	63	65	67	67
18	53	55	57	59	61	63	65	67	69	69
20	55	57	59	61	63	65	67	69	71	71
22	57	59	61	63	65	67	69	71	73	73
24	59	61	63	65	67	69	71	73	75	75
26	61	63	65	67	69	71	73	75	77	77
28	63	65	67	69	71	73	75	77	79	79
30	65	67	69	71	73	75	77	79	81	81
32	67	69	71	73	75	77	79	81	83	83
34	69	71	73	75	77	79	81	83	85	85
36	71	73	75	77	79	81	83	85	87	87
38	73	75	77	79	81	83	85	87	89	89
40	75	77	79	81	83	85	87	89	91	91

Table 12—Model 48N Air Delivery (Cfm) at Indicated External Static Pressure & Voltage (Sizes 48NLT018 thru 48NHT048) End Discharge

48N Volt/Ph/Hz	Motor Speed	External Static Pressure—Inches Water											
		208V						230V or 460V					
		0.0	0.1	0.2	0.3	0.4	0.5	0.0	0.1	0.2	0.3	0.4	0.5
48NLT018, 48NLT024, 48NHT024 208/230-1-60	△ Low	712	700	689	680	663	651	750	737	726	716	700	686
	● Med	1185	1129	1088	1026	979	922	1256	1195	1148	1081	1031	971
	‡ Hi	1370	1291	1221	1142	1063	1003	1442	1359	1285	1202	1119	1056
48NLT030, 48NMT030 208/230-1-60	△ Low	735	726	713	702	689	675	775	763	751	740	726	711
	● Med	1184	1163	1150	1134	1105	1064	1248	1226	1211	1194	1164	1120
	‡ Hi	1443	1414	1376	1329	1279	1197	1519	1489	1449	1399	1347	1261
48NHT030, LT036 48NMT036, LT042 48NMT042 208/230-1-60 208/230-3-60, 460-3-60	△ Low	1002	970	938	898	854	796	1056	1022	986	946	900	839
	● Med	1515	1452	1389	1308	1227	1102	1597	1530	1464	1378	1293	1164
	‡ Hi	1764	1705	1621	1521	1383	1254	1857	1795	1708	1603	1457	1321
48NHT036, NVT036 48NHT042 208/230-1-60 208/230-3-60 460-3-60†	△ Low	1610	1570	1504	1435	1358	1260	1787	1733	1641	1559	1458	1345
	● Med	1913	1820	1736	1645	1544	1428	1976	1909	1806	1714	1603	1495
	‡ Hi	2032	1942	1844	1759	1636	1514	2086	1983	1883	1782	1665	1545
48NLT048, NMT048 48NHT048 208/230-3-60 460-3-60†	△ Low	1627	1589	1527	1449	1364	1282	1807	1758	1704	1607	1518	1404
	● Med	1945	1880	1796	1708	1611	1508	2061	1970	1892	1813	1704	1580
	‡ Hi	2138	2045	1943	1846	1738	1624	2178	2081	1941	1869	1769	1650

(Applicable notes are listed below Table 13.)

Table 13—Down Discharge

48N Volt/Ph/Hz	Motor Speed	External Static Pressure—Inches Water											
		208V						230V or 460V					
		0.0	0.1	0.2	0.3	0.4	0.5	0.0	0.1	0.2	0.3	0.4	0.5
48NLT018 48NLT024, 48NHT024 208/230-1-60	△ Low	705	692	684	671	657	639	743	730	721	707	693	674
	● Med	1138	1102	1045	996	942	889	1196	1161	1101	1050	993	932
	‡ Hi	1308	1234	1162	1084	1020	951	1379	1301	1225	1143	1075	1002
48NLT030, 48NMT030 208/230-1-60	△ Low	724	715	706	695	682	665	763	754	744	733	719	701
	● Med	1155	1138	1120	1104	1073	1031	1218	1200	1182	1165	1132	1088
	‡ Hi	1411	1362	1326	1249	1195	1133	1493	1457	1412	1358	1274	1218
48NHT030, LT036 48NMT036, LT042, 48NMT042 208/230-1-60 208/230-3-60, 460-3-60†	△ Low	969	947	911	863	816	760	1022	998	960	910	860	801
	● Med	1494	1430	1358	1273	1174	1058	1574	1507	1431	1341	1237	1115
	‡ Hi	1683	1615	1536	1440	1274	1153	1763	1700	1619	1492	1343	1215
48NHT036, NVT036 48NHT042, NVT048 208/230-1-60 208/230-3-60 460-3-60†	△ Low	1534	1493	1430	1359	1280	1200	1704	1638	1553	1468	1390	1304
	● Med	1797	1709	1620	1547	1448	1315	1855	1707	1684	1574	1498	1361
	‡ Hi	1885	1779	1704	1608	1507	1404	1906	1821	1722	1623	1533	1410
48NLT048, 48NMT048 48NHT048 208/230-1-60 208/230-3-60 460-3-60†	△ Low	1539	1515	1466	1410	1325	1229	1735	1688	1613	1539	1440	1334
	● Med	1833	1768	1700	1599	1505	1390	1918	1849	1752	1670	1561	1442
	‡ Hi	1957	1873	1786	1699	1598	1495	1997	1907	1817	1713	1618	1506

● Factory blower motor speed setting for cooling operation.

△ Factory blower motor speed setting for heating operation.

* Air delivery values are without air filter and are for dry coil. See Table 16 for wet coil pressure drop. Deduct field-supplied air filter pressure drop and wet coil pressure drop to obtain external static pressure available for ducting.

† 460 volt units high speed only. Do not change blower speed settings.

‡ For 208V operation, change the blower motor speed setting to the next higher speed. See steps 6 and 9.

NOTE: Do not operate the unit at a cooling airflow that is less than 350 cfm per each 12,000 Btu/h of rated cooling capacity. Indoor coil icing may occur at airflows below this point.

Table 14—Model 48NT060 (Belt Drive) Air Delivery (Cfm) At Indicated External Static Pressure (in. W.C.) (Dry Coil without Air Filter*) End Discharge

RPM	PULLEY TURNS OPEN	EXTERNAL STATIC PRESSURE—INCHES WATER									
		208V					230V or 460V				
		0.0	0.2	0.4	0.6	0.8	0.0	0.2	0.4	0.6	0.8
1430	1 See Note #2	2761	2534	2343	2152	1965	2808	2588	2331	2189	2007
1380	2	2685	2444	2230	2035	1829	2716	2498	2282	2075	1864
1330	3	2583	2341	2129	1921	—	2585	2355	2154	1921	—
1280	4	2445	2174	1960	—	—	2454	2209	1966	1733	—
1230	5	2287	1964	1775	—	—	2287	2028	1780	—	—

Table 15—Model 48NT060 (Belt Drive) Air Delivery (Cfm) At Indicated External Static Pressure (in. W.C.) (Dry Coil without Air Filter*) Down Discharge

RPM	PULLEY TURNS OPEN	EXTERNAL STATIC PRESSURE—INCHES WATER									
		208V					230V or 460V				
		0.0	0.2	0.4	0.6	0.8	0.0	0.2	0.4	0.6	0.8
1430	1 See Note #2	2623	2407	2225	2044	1867	2667	2458	2243	2078	1906
1380	2	2551	2322	2118	1933	1737	2580	2373	2168	1971	1771
1330	3	2454	2221	2022	1825	—	2465	2237	2046	1825	—
1280	4	2323	2065	1862	—	—	2331	2098	1867	—	—
1230	5	2272	1866	—	—	—	2173	1927	—	—	—

NOTES: 1. Factory setting is 4 turns open.

2. Do not operate blower below 1 turn open on motor pulley. Motor overheating may result.

3. Do not operate unit in cooling mode at airflow rate below 1750 cfm. Indoor coil icing may occur.

*Air delivery values are without air filter. Air delivery values are for dry coil. See Table 16, page 10 for coil pressure drop. Deduct field supplied filter pressure drop and wet coil pressure drop to obtain external static pressure available for ducting.

Table 16—Wet Coil Pressure Drop

Airflow (CFM)	Pressure Drop (in. w.c.)
650	0.038
850	0.046
1050	0.066
1250	0.081
1450	0.111
1650	0.129
1850	0.150
2050	0.180
2250	0.198

A. Air Filter

⚠ CAUTION

Never operate the unit without a suitable air filter in the return-air duct system. Always replace the filter with the same dimensional size and type as originally installed. See Tables 2 thru 7 for recommended filter sizes.

Inspect air filter(s) at least once each month and replace (disposable-type) or clean (cleanable-type) at least twice during each heating and cooling season or whenever the filter(s) becomes clogged with dust and lint.

Replace filters with the same dimensional size and type as originally provided, when necessary.

B. Unit Top Removal

⚠ CAUTION

Condenser fan and motor are fastened to the unit top. When removing the top, use extreme care to not pull the fan motor leads loose.

NOTE: When performing maintenance or service procedures that require removal of the unit top, be sure to perform *all* of the routine maintenance procedures that require top

removal, including: inspection of the heat exchanger area, coil inspection and cleaning, and condensate drain pan inspection and cleaning.

Only qualified service personnel should perform maintenance and service procedures that require unit top removal. Refer to the following top removal procedures:

1. Turn off gas supply, *then* turn off electric power to unit.
2. Remove all screws that secure unit top, including screws around four sides and those on top that screw into internal divider panels. Save all screws.
3. Tape all side panels at each seam near unit top. Use tape strips that are at least 5-ins. long to prevent sides from falling when top is removed.
4. Lift top from unit carefully. Set top on edge and ensure that top is supported by unit side that is opposite duct (or plenum) side. *Use extreme care to prevent damage to the fan blades, motor, and insulation.*
5. Carefully replace and secure unit top to unit, using screws removed in step 3, when maintenance and/or service procedures are concluded. (Be sure to use original screws that have rubber washers to seal out water when securing top to internal divider panels.)

C. Evaporator Blower and Motor

For longer life, operating economy, and continuing efficiency; clean accumulated dirt and grease from the blower wheel and motor annually.

Lubricate the motor every 5 years if the motor is used intermittently (thermostat FAN switch in AUTO position), or every 2 years if the motor is used continuously (thermostat FAN switch in ON position).

⚠ WARNING

Turn off the gas supply, *then* disconnect and tag electrical power to the unit before cleaning and lubricating the blower motor and wheel. Failure to adhere to this warning could cause personal injury or death.

Clean and lubricate the blower motor and wheel for direct drive models as follows:

1. Remove and disassemble blower assembly as follows:
 - a. Remove blower access door.
 - b. Disconnect blower motor leads from their termination points at motor. Disconnect yellow lead from control box at capacitor. Disconnect auxiliary limit switch leads at switch.
 - c. Remove blower assembly from unit. Be careful not to tear insulation in blower compartment.
 - d. Ensure proper reassembly by marking blower wheel and motor in relation to blower housing before disassembly.
 - e. Loosen setscrew(s) that secures wheel to motor shaft, remove screws that secure motor mount brackets to housing, and slide motor and motor mount out of housing.
2. Lubricate motor as follows:
 - a. Thoroughly clean all accumulations of dirt or grease from motor housing.
 - b. Remove dust caps or plugs from oil ports located at each end of motor.
 - c. Use a good grade of SAE 20 nondetergent motor oil and put one teaspoon, 5cc, 3/16 oz., or 16 to 25 drops in each oil port.
 - d. Allow time for oil to be absorbed by each bearing, then wipe excess oil from motor housing.
 - e. Replace dust caps or plugs in oil ports.
3. Remove and clean blower wheel as follows:
 - a. Ensure proper reassembly by marking wheel orientation and cutoff plate location.
 - b. Remove screws holding cutoff plate, and remove plate from housing.
 - c. Lift wheel from housing. When handling and/or cleaning blower wheel, be sure not to disturb balance weights (clips) on blower wheel vanes.
 - d. Remove caked-on dirt from wheel and housing with a brush. Remove lint and/or dirt accumulations from wheel and housing with vacuum cleaner, using soft brush attachment. Remove grease and oil with mild solvent.
 - e. Reassemble wheel and cutoff plate into housing.
 - f. Reassemble motor into housing. Be sure setscrews are tightened on motor shaft flats and not on round part of shaft.

Clean and lubricate the blower motor and wheel as follows for belt drive models:

1. Remove blower assembly as follows:
 - a. Remove blower access door from unit.
 - b. Disconnect auxiliary limit switch leads at switch.
 - c. Remove blower assembly and motor from unit. Be careful not to tear insulation in blower compartment. Support assembly to prevent damage to motor leads.
2. Lubricate motor as follows:
 - a. Thoroughly clean all accumulations of dirt or grease from motor housing.
 - b. Remove dust caps or plugs from oil ports located at each end of motor.
 - c. Use a good grade of SAE 20 nondetergent motor oil and put one teaspoon, 5cc, 3/16 oz., or 16 to 25 drops in each oil port.
 - d. Allow time for oil to be absorbed by each bearing,

then wipe excess oil from motor housing.

- e. Replace dust caps or plugs in oil ports.
3. Remove and clean blower wheel as follows:
 - a. Remove blower belt, then remove blower pulley.
 - b. Remove blower shaft bearing retainers.
 - c. Loosen blower wheel setscrew, then pull blower shaft from wheel.
 - d. Remove screws holding cutoff plate, then remove cutoff plate.
 - e. Lift wheel from housing. When handling and/or cleaning, be sure not to disturb balance weights on blower wheel vanes.
 - f. Remove caked-on dirt from wheel and housing with a brush. Remove lint and/or dirt accumulations from wheel and housing with vacuum cleaner, using soft brush attachment. Remove grease and oil with mild solvent.
 - g. Reassemble wheel and cutoff plate into housing.
 - h. Reinstall blower shaft, bearing retainers, blower pulley, and belt.
4. Reinstall blower assembly into unit, route blower motor leads into control compartment, and reconnect all blower motor leads to proper termination point in unit control box. Replace panels.
5. Restore electrical power, then gas supply to unit. Start unit and check for proper blower rotation and motor speeds during heating and cooling cycles.

D. Heating Section

Ensure dependable and efficient heating operation by inspecting the heating section before each heating season, and cleaning when necessary.

Proceed as follows to inspect and clean heating section:

1. Turn off gas and power to unit.
 2. Remove burner access door.
 3. Disconnect two wires from inducer motor.
 4. Remove complete inducer assembly from unit.
 5. Remove screws that secure collector box to heat exchanger, exposing flue openings.
 6. Remove flue choke.
 7. Using field-provided small wire brush, steel spring cable, reversible electric drill, and vacuum cleaner; clean cells.
 - a. Assemble wire brush and steel spring cable.
 - (1) Use 4-ft of 1/4-in. diameter high-grade steel spring cable (commonly known as drain cleanout or Roto-Rooter cable).
 - (2) Use 1/4-in. diameter wire brush (commonly known as 25-caliber rifle cleaning brush).
- NOTE:** The items called for in sections 1 and 2 can be purchased at a local hardware store.
- (3) Insert twisted wire end of brush into end of spring cable, and crimp tight with crimping tool or strike with ball-peen hammer. *Tightness is very important.*
 - (4) Remove metal sleeve from wire brush to allow proper brush action.
- b. Clean each heat exchanger cell.
 - (1) Attach variable-speed reversible drill to end of spring cable (end opposite brush).
 - (2) Insert brush end of cable into upper opening of cell and slowly rotate with drill. *Do not* force cable. Gradually insert at least 3-ft of cable into two upper passes of cell.

- (3.) Work cable in and out of cell three or four times to obtain sufficient cleaning. *Do not* pull cable with great force. Reverse drill and gradually work cable out.
 - (4.) Remove burner assembly.
 - (5.) Insert brush end of cable in lower opening of cell, and proceed to clean in same manner.
 - (6.) Repeat foregoing procedures until each cell in unit has been cleaned.
 - (7.) Using vacuum cleaner, remove residue from each cell.
 - (8.) Using vacuum cleaner with soft brush attachment, clean burner assembly.
 - (9.) Reinstall burner assembly.
8. After cleaning, check sealant and gaskets to ensure that they have not been damaged. If new sealants or gaskets are needed, contact your Distributor.
 9. Reinstall flue choke. Be sure all screws are in and tight.
 10. Clean and replace flue collector assembly, making sure all screws are secure.
 11. Replace inducer assembly.
 12. Reconnect two wires to inducer motor.
 13. Replace burner access door.
 14. Turn on power and gas.
 15. Set thermostat and check unit for proper operation.

E. Pilot

Inspect the pilot and clean (when necessary) at the beginning of each heating season. Remove the accumulation of soot and carbon from the pilot. The pilot flame must be high enough for proper impingement on the flame sensor. Pilot flame must also come in contact with the pilot hood (target) for proper operation. If the pilot flame appears too hard (lifting and blowing) or too soft (unstable) check inlet gas pressure for proper value. See Table 8. The spark electrode must be located so the spark travels through a combustible mixture of gas, if necessary, readjust the electrode as shown in Fig. 11 be certain to maintain the 1/8-in. spark gap.

F. Condenser Coil, Evaporator Coil, and Condensate Drain Pan

Inspect the condenser coil, evaporator coil, and condensate drain pan at least once each year. Proper inspection and cleaning requires the removal of the unit top. See part B of this section.

The coils are easily cleaned when dry; therefore, inspect and clean the coils either before or after each cooling season. Remove all obstructions, including weeds and shrubs that interfere with the airflow, through the condenser coil. Straighten bent fins with a fin comb. If coated with dirt or lint, clean the coils with a vacuum cleaner, using the soft brush attachment. Be careful not to bend the fins. If coated with oil or grease, clean the coils with a mild detergent-and-water solution. Rinse coils with clear water, using a garden hose. Be careful not to splash water on motors, insulation, wiring, or air filter(s). For best results, spray condenser coil fins from inside to outside the unit. On units with an outer and inner condenser coil, be sure to clean between the coils. Be sure to flush all dirt and debris from the unit base.

Inspect the drain pan and condensate drain line when inspecting the coils. Clean the drain pan and condensate drain by removing all foreign matter from the pan. Flush the pan and drain tube with clear water. Do not splash water on the insulation, motor, wiring, or air filter(s). If the drain tube is restricted, clear it with a "plumbers snake" or similar probe device.

G. Condenser Fan

▲ CAUTION

Keep the condenser fan free from all obstructions to ensure proper cooling operation. Never place articles on top of the unit. Damage to unit may result.

Remove control and compressor access panels. Inspect the fan blades for cracks or bends each year. *Ensure that blades clear the motor by no more than 1/4-in.* If the blade assembly has slipped down the motor shaft, adjust the fan position on the motor shaft by loosening the setscrew(s), then moving the blade assembly up. Be sure that the setscrew(s) is on the flat(s) of the motor shaft before tightening.

H. Electrical Controls and Wiring

Inspect and check the electrical controls and wiring annually. *Be sure to turn off the gas supply and then the electrical power to the unit.*

Remove the control, blower, and compressor compartment access panels to locate all the electrical controls and wiring. Check all electrical connections for tightness. Tighten all screw connections. If any smoky or burned connections are noticed: disassemble the connection, clean all the parts, restrip the wire end, and reassemble the connection properly and securely.

After inspecting the electrical controls and wiring, replace all the panels. Start the unit, and observe at least one complete heating cycle and one complete cooling cycle to ensure proper operation. If discrepancies are observed in either or both operating cycles, or if a suspected malfunction has

Table 17—Piston Sizes

Unit	Piston Identification
018	59
024	63
030	70
036	76
042	80
048	86
060	98

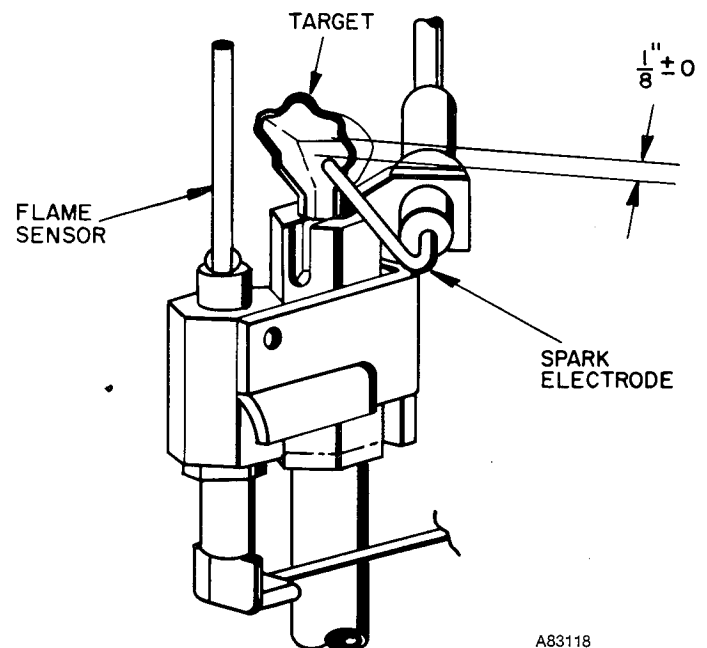
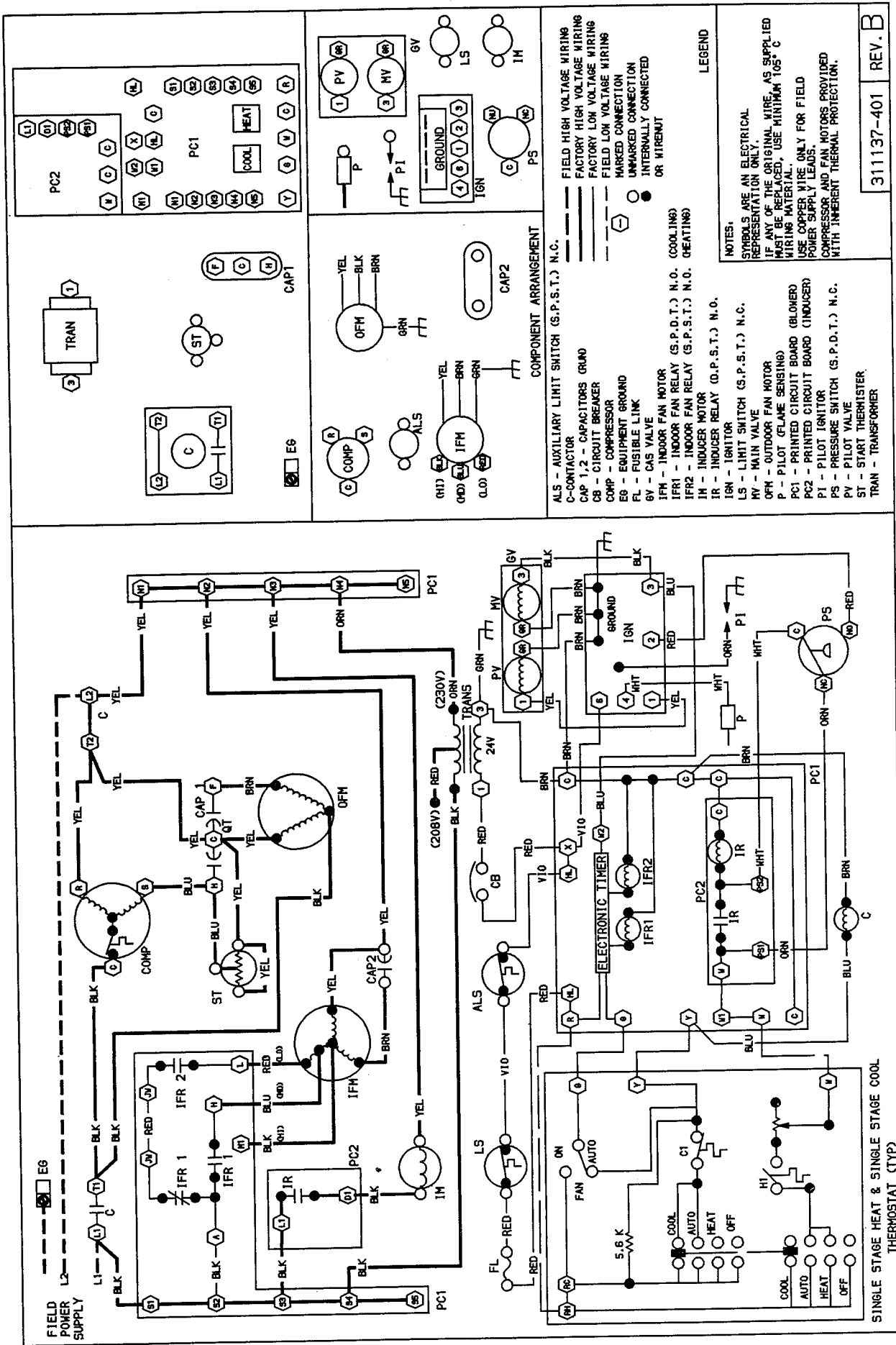

Fig. 11—Position of Electrode to Pilot

A83118



311137-401 REV. B

Fig. 12—Wiring Schematic—1 Phase-230V (Typical)

A88078

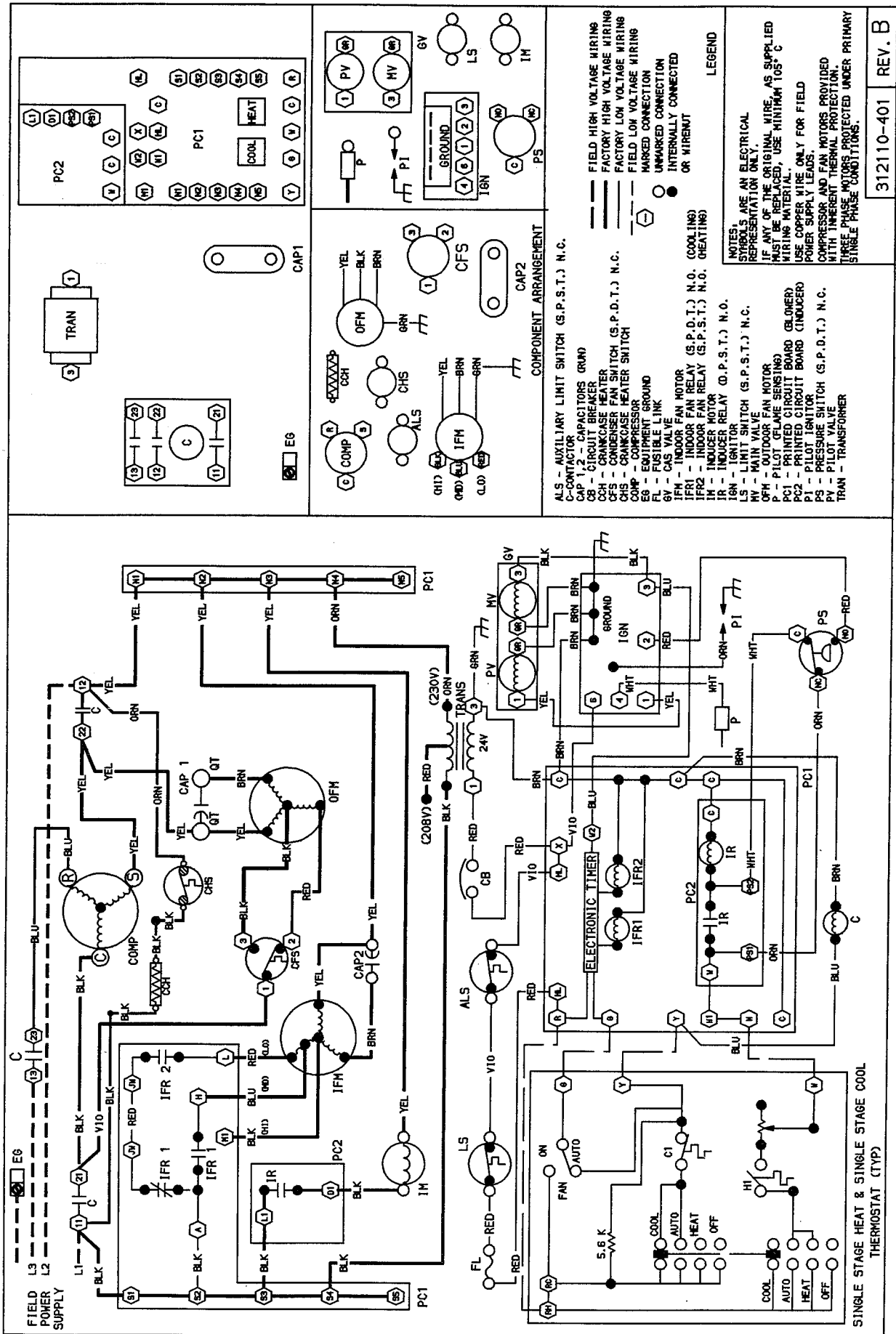

312110-401 REV. B

Fig. 13—Wiring Schematic—3 Phase-230V (Typical)

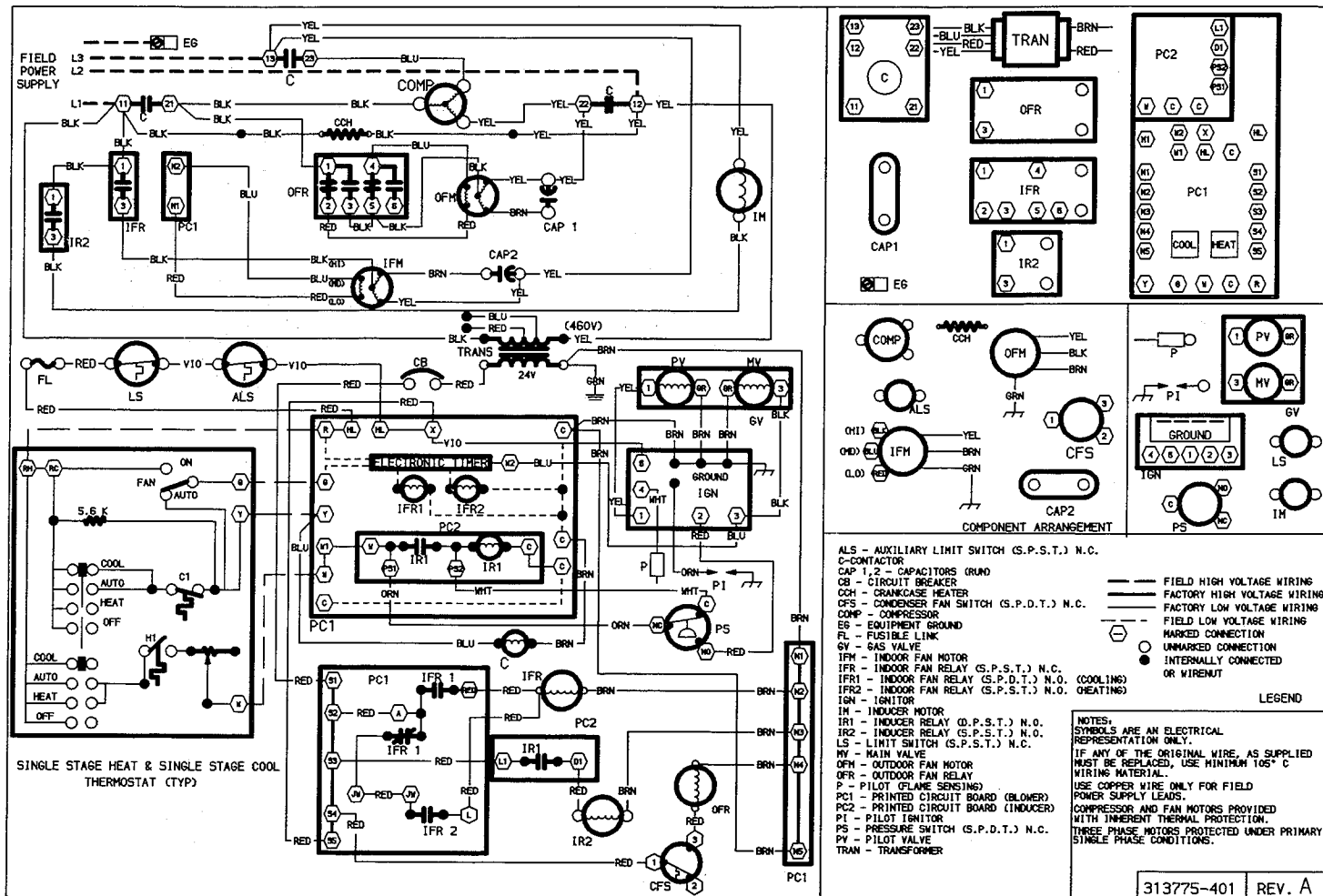

Fig. 14—Wiring Schematic—3 Phase-460V (Typical)

A88224

occurred, check each electrical component with the proper electrical instrumentation. Refer to the unit wiring label when making these checkouts.

NOTE: Refer to the heating and/or cooling sequence of operation in this publication as an aid in determining proper control operation.

I. Refrigerant Circuit

Inspect all refrigerant tubing connections and the unit base for oil accumulations annually. Detecting oil generally indicates a refrigerant leak.

If oil is detected or if low cooling performance is suspected, leak-test all refrigerant tubing; using an electronic leak-detector, halide torch, or liquid-soap solution. If a refrigerant leak is detected, see Step 7, part B, "Refrigerant Leaks," in this publication.

If no refrigerant leaks are found and low cooling performance is suspected, see Step 9, part B, "Checking and Adjusting Refrigerant Charge," in this publication.

J. Gas Input

The gas input does not require checking unless improper heating performance is suspected. If a problem exists, refer to Step 8 of this publication.

K. Evaporator Airflow

The heating and/or cooling airflow does not require checking unless improper performance is suspected. *If a problem exists, be sure that all supply- and return-air grilles are open and free from obstructions, and that the air filter is clean.* When necessary, refer to Step 9, part C, of this publication to check the system airflow.

L. Metering Device Servicing

See Fig. 15 for metering device components. The piston has a refrigerant metering orifice through it. The retainer forms a sealing surface for liquid line flare connection. To check, clean or replace piston:

1. Shut off power to unit.
2. Remove refrigerant from unit using approved refrigerant removal methods.
3. Remove liquid line flare connections from metering device.
4. Note position of arrow on metering device with respect to unit.
5. Pull retainer out of body. Be careful not to scratch flare sealing surface. If retainer does not pull out easily, carefully use locking pliers to remove retainer. Replace scratched or damaged retainer.
6. Slide piston out by inserting a small soft wire through metering hole (18-gage thermostat wire). See that metering hole, sealing surface around piston cones and fluted portion of piston are not damaged.
7. Chart on unit access panel illustrates proper arrangement and size of piston. See Table 17 for piston sizes.
8. Clean piston refrigerant metering orifice.
9. Replace retainer O-ring Part No. is 99CC501052.

M. Liquid Line Strainer

The Liquid Line Strainer (to protect metering device), is made of wire mesh and located in the liquid line on inlet side. Strainer is pressed into the line. Remove strainer by threading a No. 10 sheet metal screw into strainer and pulling the screw with pliers.

Table 18—Heating Service Analysis Chart

SYMPTOM	CAUSE	REMEDY
Pilot will not light.	No spark at electrode	Check air gap between electrode tip and pilot target. Gap should be as shown in Fig. 11. Readjust as necessary. Clean moisture or dirt accumulation on electrode ceramic with cloth. Cracked ceramic—replace pilot electrode assembly. Check for loose or broken wiring at and between electronic control head and electrode. Replace wire or tighten connection as necessary. Check fuses or circuit breaker to insure voltage to unit. Check for 24-volts between 2 and GR, and between 6 and GR. If you read 24 volts and above steps have been completed, replace electronic control head portion of control head/gas valve assembly.
	Spark shorting out to main burner	Realign electrode tip away from main burner but maintain spark gap to pilot burner. See Fig. 11.
	No gas at pilot burner	Clean pilot orifice. Check inlet pressure to gas valve. Recommended operating pressure 7-in. w.c. natural gas, 11-in w.c. LP gas. 0.5 psig (14-in w.c.) max. pressure Check for 24 volts between terminals 1 and GR. If you read 24 volts and above steps have been completed, replace gas valve portion of control head/gas valve assembly.
Burners will not ignite.	Water in gas line	Drain—install water trap.
	No power to furnace	Check power supply, fuses, wiring, or circuit breaker.
	No 24-volt power supply to control circuit	Check transformer—replace if necessary.
	Miswired or loose connections	Check all wiring and wirenut connections.
	Dirty pilot—yellow flame	Clean pilot orifice.
	Pilot burning improperly—sharp blue flame	Replace pilot.
	Burned-out heat anticipator in thermostat	Replace thermostat.
Inadequate heating	Dirty air filter	Clean or replace filter as necessary.
	Gas input to furnace too low	Check gas pressure at manifold. Clock gas meter for input. If too low, increase manifold pressure, or replace with correct orifices.
	Unit undersized for application	Replace with proper unit—or add additional unit.
	Restricted airflow	Clean or replace filter—or remove any restriction.
	Blower speed too low	Use faster speed tap—or install optional blower.
	Limit switch cycles main burners	Dirty air filters—clean or replace. Registers closed, restricted ductwork—open or remove restriction. Check heat anticipator setting on thermostat—readjust.
Poor flame characteristics	Incomplete combustion results in:	Check all screws around flue outlets and burner compartment—tighten.
	Aldehyde odors, (CO), sooting flame—floating flame	LACK OF COMBUSTION AIR.
		Cracked heat exchanger—replace.
		Overfired furnace—reduce input, or change orifices.
		Check vent for restriction—clean as required.
		Check orifice to burner alignment.

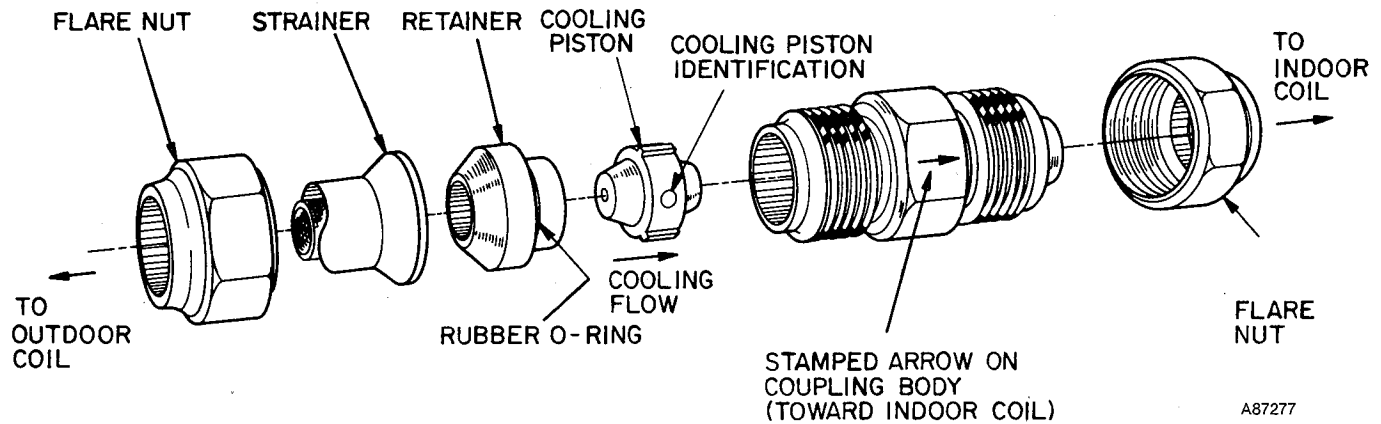

Fig. 15—Metering Device Components

Table 19—Cooling Service Analysis Chart

SYMPTOM	CAUSE	REMEDY
Compressor and condenser fan will not start.	Power failure	Call power company.
	Fuse blown or circuit breaker tripped	Replace fuse or reset circuit breaker.
	Defective thermostat, contactor, transformer, or control relay	Replace component.
	Insufficient line voltage	Determine cause and correct.
	Incorrect or faulty wiring	Check wiring diagram and rewire correctly.
	Thermostat setting too high	Lower thermostat setting below room temperature.
Compressor will not start but condenser fan runs.	Faulty wiring or loose connections in compressor circuit	Check wiring and repair or replace.
	Compressor motor burned out, seized, or internal overload open	Determine cause. Replace compressor.
	Defective run/start capacitor, overload, start relay	Determine cause and replace.
	One leg of three-phase power dead	Replace fuse or reset circuit breaker. Determine cause.
Compressor cycles. (other than normally satisfying thermostat)	Refrigerant overcharge or undercharge	Blow refrigerant, evacuate system, and recharge to nameplate.
	Defective compressor	Replace and determine cause.
	Insufficient line voltage	Determine cause and correct.
	Blocked condenser	Determine cause and correct.
	Defective run/start capacitor, overload, or start relay	Determine cause and replace.
	Defective thermostat	Replace thermostat.
	Faulty condenser fan motor or capacitor	Replace.
Restriction in refrigerant system	Locate restriction and remove.	
Compressor operates continuously.	Dirty air filter	Replace filter.
	Unit undersized for load	Decrease load or increase unit size.
	Thermostat set too low	Reset thermostat.
	Low refrigerant charge	Locate leak, repair, and recharge.
	Leaking valves in compressor	Replace compressor.
	Air in system	Blow refrigerant, evacuate system, and recharge.
Condenser coil dirty or restricted	Clean coil or remove restriction.	
Excessive head pressure	Dirty air filter	Replace filter.
	Dirty condenser coil	Clean coil.
	Refrigerant overcharged	Purge excess refrigerant.
	Air in system	Blow refrigerant, evacuate system, and recharge.
Condenser air restricted or air short-cycling	Determine cause and correct.	
Head pressure too low	Low refrigerant charge	Check for leaks, repair, and recharge.
	Compressor valves leaking	Replace compressor.
	Restriction in liquid tube	Remove restriction.
Excessive suction pressure	High heat load	Check for source and eliminate.
	Compressor valves leaking	Replace compressor.
Suction pressure too low	Refrigerant overcharged	Purge excess refrigerant.
	Dirty air filter	Replace filter.
	Low refrigerant charge	Check for leaks, repair, and recharge.
	Metering device or low side restricted	Remove source of restriction.
	Insufficient evaporator airflow	Increase air quantity. Check filter—replace if necessary.
	Temperature too low in conditioned area	Reset thermostat.
	Outdoor ambient below 55 F	Install low-ambient kit.
Field-installed filter-drier restricted	Replace.	

Manufacturer reserves the right to discontinue, or change at any time, specifications or designs without notice and without incurring obligations.