

SUPERSEDED BY 48DH-05L 5-70
Combination Heating/Cooling Units

The 48DH and DL are complete systems designed for installation outdoors on a slab or rooftop. Installation consists of: mounting unit; single gas, electrical, and condensate connections; thermostat lead connections and necessary duct-work. A field-furnished filter rack must be located in the return air stream.

PREINSTALLATION

1. Examine for damage incurred during shipment. If damage is found, immediately file claim with transit company.
2. Examine nameplate to verify that electrical requirements match available power supply.
3. Do not remove shipping skid until unit is ready for mounting.

INSTALLATION

(Refer to Fig. 1 and Table 1)

Unit Location

GENERAL – Locate unit as close as possible to duct openings. Do not install in an indoor space. Neither condenser air inlet nor flue outlet is affected by wind. Unit may be mounted to face any compass direction. Avoid locating unit near sources of contaminated air.

Although unit is weatherproof, guard against water from higher grade runoff and overhangs.

OUTSIDE AIR LIMITATION – Although there are no restrictions on the temperature or percentage of outdoor air circulated through the unit, the rate of condensation of combustion products will increase as the return air temperature drops below 50 F. *Protect against possible ice buildup at the drain holes of the bottom pan if all outside air is used below freezing temperatures.*

VIBRATION ISOLATION – Unit components are mounted to eliminate vibration. In some cases, single rubber pad type isolators may be desired due to type of roof construction. Isolators are not required for slab mounting.

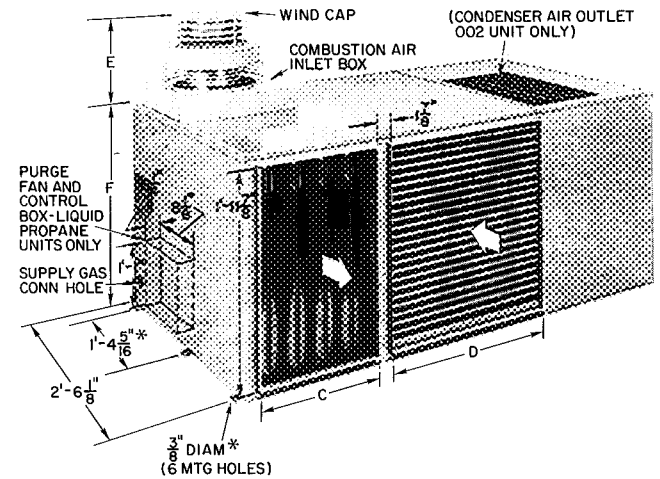
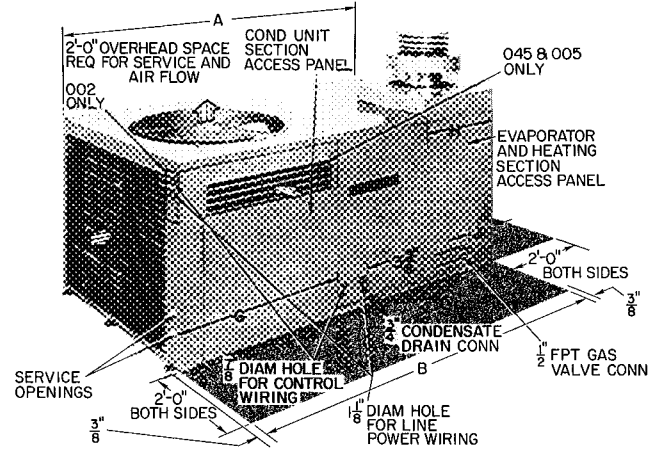

*This dimension is not applicable to 002 units because there are no mounting rails

Space required for service Design certified by A.G.A. for installation on combustible type floor with a minimum clearance space of 1 in. on duct connection side, and 12 in. on remaining sides

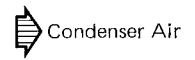

Fig. 1 – Physical Data

Table 1 – Base Unit Dimensions (ft-in.)

UNIT	48DL	48DH	48DL	48DL	48DH	48DL	48DL	48DH
	002*		003	004		005	005	
A	3-10	3-10	4- 7	4- 7	5- 2	5- 2	5- 2	5- 7 ³ / ₄
B	—	—	4- 7 ³ / ₄	4- 7 ³ / ₄	5- 2 ³ / ₄	5- 2 ³ / ₄	5- 2 ³ / ₄	5- 8 ⁵ / ₈
C	0-10 ¹ / ₂	0-10 ¹ / ₂	0-10 ¹ / ₂	0-10 ¹ / ₂	1- 5 ¹ / ₂	1- 3 ⁵ / ₈	1- 3 ⁵ / ₈	1- 9
D	0-11 ¹ / ₂	0-11 ¹ / ₂	1- 2	1- 8	1- 8	1-11	1-11	1-11
E	1- 0	1- 0	1- 0	1- 0	1- 0	1- 0	1- 0	1- 0 ⁷ / ₈
F	3- 2 ³ / ₈	3- 2 ³ / ₈	3- 2 ⁵ / ₈	3- 2 ⁵ / ₈	3- 2 ⁵ / ₈	3- 2 ⁵ / ₈	3- 2 ⁵ / ₈	3- 3 ¹ / ₂
G	—	—	2- 2 ¹ / ₈	2- 2 ¹ / ₈	2- 2 ¹ / ₈	2- 4 ¹ / ₂	2- 4 ¹ / ₂	2- 4 ¹ / ₂
H	0-11 ¹ / ₈	0-11 ¹ / ₈	0-11 ¹ / ₈	0-11 ¹ / ₈	1- 4 ¹ / ₂	1- 4 ¹ / ₂	1- 4 ¹ / ₂	1- 4 ¹ / ₂
J	0- 4	0- 4	0- 4	0- 4	0-11	0- 7 ¹ / ₂	0- 7 ¹ / ₂	1- 2 ¹ / ₂

*Refer to Fig 2 for differences of these series

Table 2 – Physical Data

UNIT	48DL002	48DH002	48DL003	48DL004	48DH004	48DL045	48DL005	48DH005
OPERATING WT (lb)	331	343	385	411	438	450	476	512
REFRIG (22) CHG (lb-oz)	3 2	3 2	3 6	5.1	5 1	5 2	5 1	5 1
COMPRESSOR	M27 (1-ph) AH5527E(3-ph)	M27 (1-ph) AH5527E(3-ph)	M34	M40	M40	YRC4-0350	R542	R542
Cylinders	2	2	2	2	2	2	3	3
Rpm (60-Hz)				3500				
CONDENSER FAN	Propeller-Type – Direct Drive; Vertical Discharge							
Air Quantity (Cfm)	1700	1700	2000	2500	2500	2700	2700	2700
Motor Hp	1/5	1/5	1/5	1/5	1/5	1/5	1/5	1/5
EVAPORATOR FAN	Centrifugal – Direct Drive; Horizontal Discharge							
CAPACITY (1000 Btuh)								
Cooling	24	24	30	36	36	42	48	48
Heating/Bonnet	56/42	80/60	80/60	80/60	125/93 75	100/75	110/82.5	150/112 5
MAX EXTERNAL STATIC PRESSURE Heating (in. W.C.)	40							
FILTERS* (1-in. thick)								
Disposable – No. ...								
Size (in.)	1 20x25	1 20x25	2 15x20	1 20x20	1 15x20	1 20x20	1 20x25	1 20x25
Permanent – No. ...								
Size (in.)	1...15x20	1 15x20	1 20x20	1 20x20	1 20x20	1 20x25	2.. 15x20	2 15x20
HEAT TEMP RISE (F)	35-65	45-75	35-65	35-65	45-75	35-65	35-65	45-75

*Recommended field-supplied filter

†Based on 0.082 in. wg pressure drop or less thru filter at 520 ft/min face velocity

Unit Support

GENERAL – The unit should be level from end to end and pitched away from supply/return/connect duct slightly toward the condensate drain connection on the service access face of the unit. The amount of this pitch should be between 3/8 in. and 1/2 inch. This should apply to all of the following methods of mounting.

SLAB MOUNTING should be poured at site or a preformed concrete slab used. Construct as follows and refer to Table 1:

- Top above finished grade 2 in.
- Thickness (min) 6 in.
- Width approx 6 in. more than A
- Length approx 6 in. more than B

GRAVEL APRON (12 in. minimum) in front of outdoor coil is recommended to prevent grass or foliage from obstructing outdoor air flow.

FLAT OR RECESSED ROOFTOP MOUNTING should be as close as possible to roof opening and rest on at least two wooden 2 x 4 in. or 2 x 6 in. sleepers.

Sleepers may run perpendicular or parallel to unit mounting rails, but must span at least two roof joists or purlins to distribute weight. Set sleepers in roof cement or mastic. Do not plug drain holes in compressor or furnace compartment.

PITCHED ROOF MOUNTING – Construct solid level supporting frame of angle iron pieces, at least 1-1/2 in. x 1-1/2 in. x 1/4 in., welded or bolted together and secured to roof with lag screws. Run frame members perpendicular to unit rails and make provision for securing unit. Use roof cement or mastic where structure is in contact with roof.

Unit Rigging and Mounting

1. Sling unit perpendicular to shipping skid runners. Use spreader bars to prevent rigging cable or sling damage to unit.
2. Raise unit to location and remove shipping skid.
3. Mount and level unit as indicated in Unit Support section. Use unit frame for leveling reference.
4. Set rails of slab-mounted units in semiliquid roof cement or mastic to prevent water collection under rails.

DUCTWORK AND FILTER RECOMMENDATIONS

Ductwork

1. Select and size according to Carrier System Design Manual, Part 1. System air flow must be within temperature rise range and external static pressure shown on A.G.A. rating plate. All ductwork external to building must be weatherproof and insulated.
2. Insulate ducts passing thru unconditioned spaces and provide a vapor barrier.
3. Fit ducts to unit with flexible connections to dampen vibration.
4. Bolt or screw ductwork to unit flanges.
5. Seal joint with sheet metal flashing.
6. If a single-split duct is connected to unit, division between supply and return must be gasketed to prevent air bypass.

Filter (Field Supplied)

1. Locate in return air system. Convenient location for filter is inside building, behind return air grille. Refer to Filters, Table 2.
2. Attach manufacturers' filter instructions to filter rack.

WIND CAP AND COMBUSTION AIR INLET BOX ASSEMBLY

Shipping — Windcap and combustion air inlet box assembly of units 48DH,DL002 are shipped separately. For all other 48DH,DL units, the windcap and combustion air inlet box assembly is found in the compressor compartment. Refer to Fig. 2 and proceed to remove this assembly.

1. Remove 6 sheet metal screws holding top grille and condenser fan assembly.
2. Lift condenser grille, fan motor and orifice assembly from top cover.
3. Remove two screws holding windcap banding and remove windcap parts.
4. Mount item 1 (combustion inlet air box) on top cover of unit, with horizontal flange on box to slide into retaining clip on top cover. Tighten the S.M. screws on box.

Assemble to Units — To assemble the windcap and combustion air inlet box assembly to all 48DH,DL units, refer to Fig. 3 and proceed as follows:

1. Place item 2 at circular extrusion of top cover.
2. Slide windcap assembly pipe into flue box collar.
3. Secure windcap assembly to combustion air inlet box with 3 S.M. screws through eyelets of wire cage.

PIPING

Gas — Make necessary connections incorporating following recommendations:

1. Refer to latest revision of American National Standard Z21.30 entitled "Installation of Gas Appliances and Gas Piping," published by American Gas Association, 1515 Wilson Blvd., Arlington (Rosslyn), Virginia 22209. Comply with latest national and local codes.
2. Size supply pipe for 0.3-in. wg maximum pressure drop. Never use supply pipe smaller than gas supplier and/or Table 3.
3. Use pipe dope that is approved for liquified petroleum gases.
4. Grade all pipe 1/4 in. per 15 ft to prevent trapping condensed moisture. Grade all horizontal runs to risers, from risers to meter and from unit to riser.
5. Support piping to maintain proper grade, prevent straining unit controls, and prevent accidental movement of piping.
- 6. Provide dirt and moisture drip pocket upstream of unit below unit control level. Connect tee to line with straight-thru section of tee vertical. Connect 5-in. capped nipple to tee to act as drip pocket. *Drip pocket should not be subjected to freezing temperatures.*

Where pipe comes to unit from vertical riser, with or without short horizontal leg, provide 5-in. drip pocket at base of riser.

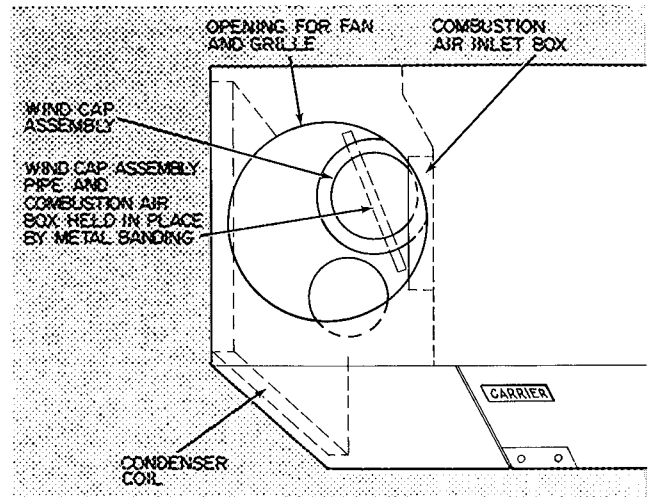

Fig. 2 — Removal From Shipping Location

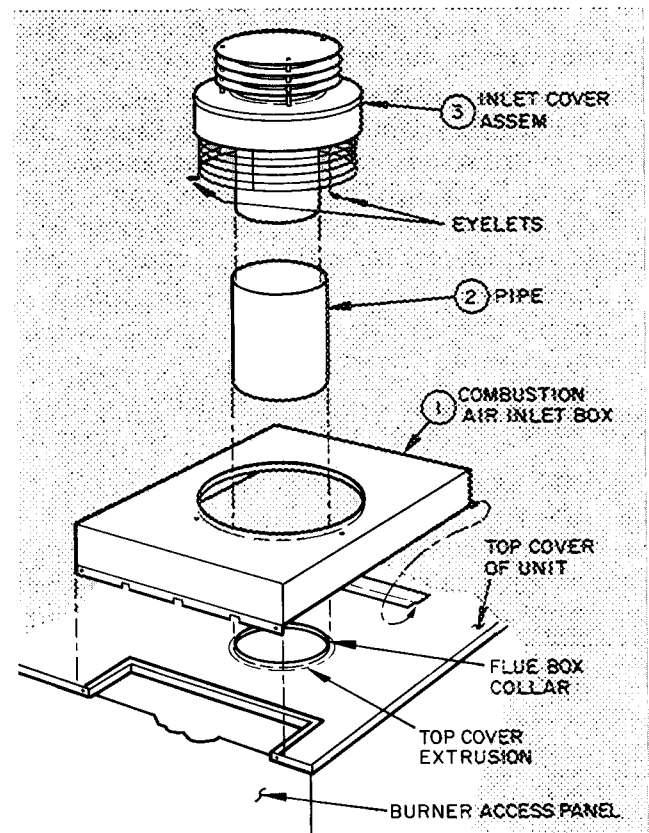

Fig. 3 — Wind Cap and Air Box Assembly

Table 3 — Maximum Pipe Cap. (Cfh)*

PIPE LENGTH (ft)	NOMINAL PIPE SIZE (in.)			
	1/2	3/4	1	1 1/4
10	132	278	520	1050
20	92	190	350	730
30	73	152	285	590
40	63	130	245	500
50	56	115	215	440
60	—	105	195	400
70	—	96	180	370
80	—	90	170	350
90	—	84	160	320
100	—	79	150	305

*Cfh — Cu ft/hr based on 0.3 in. wg pressure drop and 0.6 gas sp gr

NOTE

Correction is not necessary for normal number of fittings nor for 0.7 gas sp gr unless specified

7. *Protect gas piping from freezing temperatures.* Exposure to wide or sudden temperature changes *requires* insulation to prevent stoppages in piping.
- 8. Install manual shut-off valve external to unit as required by local utility regulations and installation codes. Install a ground joint union in the gas supply line to the gas valve in the burner compartment.
9. After piping is complete, check for leaks with soap and water solution. Do not use an open flame for this purpose.

CONDENSATE DRAIN — Connection (3/4-in. male pipe thread) is on service access face of unit. Drain is on the suction side of the evaporator fan and must be trapped to prevent leakage into the unit. Trap should be at least 3 in. deep and made either of a flexible material or in a manner to resist freezing damage during winter.

Power Supply and Wiring — Units are factory wired for voltage shown on nameplate. Voltage at unit must be within ± 10 percent of nameplate voltage. (Refer to Table 4.) On three-phase units, phase unbalance must be within 2 percent. Contact local power company for corrections if necessary.

Operation of unit on improper line voltage or excessive phase unbalance is considered abuse and is not covered by Carrier Warranty.

Provide a fused disconnect switch of adequate size within sight of unit and out of reach of

children. Provision for locking switch open (off) is advisable to prevent power from being turned on while unit is being serviced if disconnect is not visible from unit. Disconnect switch, fuses and field wiring must comply with National Electrical Code and local requirements.

Approved aluminum-copper connectors should be used if aluminum power wiring is used.

REMOTE CONTROL CENTER ACCESSORY (combination heating-cooling thermostat and switch subbase) — Instructions for installation are included with accessory. Locate thermostat on an inside wall or column where it will be affected only by average temperature of room. Subbase has slots for direct mounting on wall or vertical outlet box.

Run thermostat cable or equivalent single leads of no. 18 colored wire from subbase terminals, thru 7/8-in. hole in access side of unit, to low-voltage terminals of junction box (Fig. 4).

After thermostat wiring is complete, mount thermostat to subbase following instructions included with control. Do not turn on power to unit at this time. Anticipator setting is 0.6 amp for natural gas units and 0.4 amp for LP gas units.

Upon completion of unit installation, refer to Start-Up and Service Instructions.

ACCESSORY START CAPACITOR PACKAGE — Instructions for installation are included with this accessory.

Table 4 — Electrical Data (60-Hz)

UNIT		VOLTAGE Nom V/Ph	UNIT				COMPR		IFM	OFM
Model	Series		WSA	FLA	ICF	FU	FLA	LRA	FLA	
48DL, DH 002	200	208/1	23.5	19.5	83.4	35	16.1	80.0	2.0	1.4
	300	230/1	21.6	17.9	75.4	30	14.5	72.0	2.0	1.4
	400	208/3	16.8	14.0	58.4	20	10.6	55.0	2.0	1.4
48DL 003	200	208/1	29.8	24.3	102.8	40	20.8	99.0	2.4	1.4
	300	230/1	27.3	22.3	91.8	35	18.8	88.0	2.4	1.4
	400	208/3	18.8	15.5	73.8	25	12.0	70.0	2.4	1.4
	500	230/3	17.4	14.4	63.8	25	10.9	60.0	2.4	1.4
	600	460/3	10.7	9.0	33.8	15	5.5	30.0	2.4	1.4
48DL, DH 004	200	208/1	39.0	32.4	117.9	50	26.5	112.0	3.1	2.8
	300	230/1	35.9	29.9	105.9	45	24.0	100.0	3.1	2.8
	400	208/3	25.0	21.2	85.9	30	15.3	80.0	3.1	2.8
	500	230/3	23.3	19.8	75.9	20	13.9	70.0	3.1	2.8
	600	460/3	14.2	12.9	40.9	20	7.0	35.0	3.1	2.8
48DL 045	200	208/1	43.5	36.1	120.6	45	29.5	114.0	3.8	2.8
	300	230/1	40.0	33.3	110.6	45	26.7	104.0	3.8	2.8
	400	208/3	27.9	23.6	98.6	30	17.0	92.0	3.8	2.8
	500	230/3	25.9	22.0	98.6	30	15.4	92.0	3.8	2.8
	600	460/3	16.2	14.3	52.6	20	7.7	46.0	3.8	2.8
48DL, DH 005	200	208/1	46.6	38.6	136.6	60	32.0	130.0	3.8	2.8
	300	230/1	42.4	35.2	124.6	50	28.6	118.0	3.8	2.8
	400	208/3	29.7	25.1	96.6	40	18.5	90.0	3.8	2.8
	500	230/3	27.5	23.3	85.1	35	16.7	78.5	3.8	2.8
	600	460/3	17.0	10.8	45.6	25	8.3	39.3	3.8	2.8

FLA — Full Load Amps

FU — Fuse (max allowable amps)

ICF — Max Instantaneous Current Flow during start-up is the sum of compressor LRA plus the FLA of all other motors in the unit

IFM — Indoor Fan Motor

LRA — Locked Rotor Amps

OFM — Outdoor Fan Motor

WSA — Wire Sizing Amps per NEC equals $1.25 \times$ FLA of the largest motor plus the sum of all other motors in the unit

THERMOSTAT COMBINATIONS FOR ALL UNITS

- 1 HHO7AT074 AND SUBBASE HH93AZ076
- 2 HHOIAD042 AND SUBBASE HH93AZ042
- 3 HHOIAD040 AND SUBBASE HH93AZ042

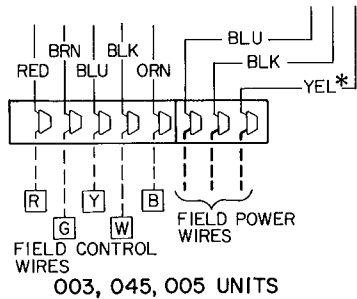
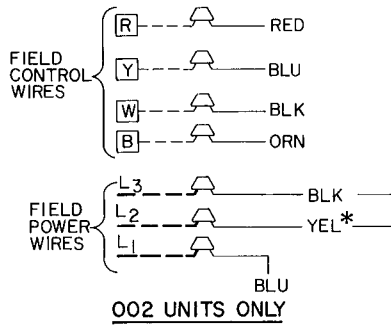

- THERMOSTAT CONNECTIONS
- ⊔ SPLICE CONNECTION
- FIELD POWER WIRING
- FIELD CONTROL WIRING
- FACTORY WIRING

* NOT CONNECTED WHEN SINGLE-PHASE POWER INPUT IS USED

Fig. 4 — Remote Control Wiring for Thermostat Combinations

UNIT CONNECTION

1. Secure field power conduit to the 1-1/8 in. hole located directly in front of the high-voltage junction box.
2. Route conduit to allow control box to swing down to a horizontal position for access to blower compartment.
3. Splice field power wires to the pigtail leads in the junction box. (Wire nuts are provided for either copper or aluminum field wire.) These will have to be field insulated.
4. Route control voltage field wiring through a 7/8 in. hole located directly in front of the low-voltage splice compartment. If conduit is not used, the wires may be protected by inserting the diaphragm grommet into the hole. *Make all connections to pigtail leads, but do not use aluminum control wire for a splice connection to the copper pigtails.*

START-UP

General — Compressor is internally spring mounted. Do not loosen or remove hold-down bolts. *Before turning on power to the unit, check the following.*

1. Remove blower wheel support. Before applying power to unit, the blower wheel support must be removed from its shipping location. (Refer to Fig. 5.)

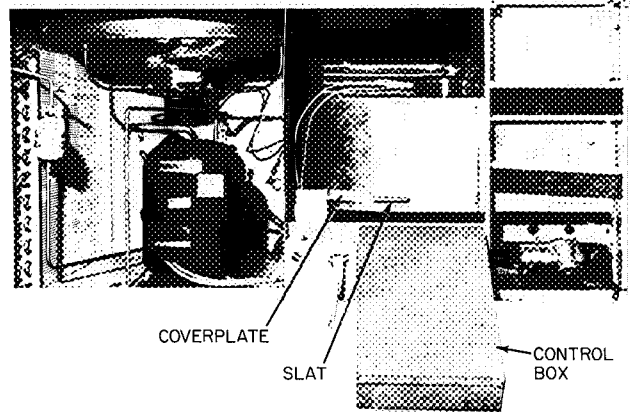

Fig. 5 — Removal of Blower Wheel Support

- a. Remove heating access panel, then remove upper right side screw holding the control box to the partition.
 - b. On all units except 48DH,DL002, remove upper right side screw on control box and swing control box to a horizontal position.
 - c. Loosen the 5 screws holding partition and remove partition.
 - d. Loosen three bolts (about 1/8 in.) holding motor bracket to fan.
 - e. Grasp wooden slat with pliers and pull slat out completely.
 - f. Swing cover plate over hole in fan housing and secure with sheet metal screw.
 - g. Remove sheet metal screw holding outboard blower housing support on left side of blower housing and remove support. Check that blower wheel rotates freely before replacing inner panel. *Do not retighten motor bracket hold-down bolts.*
2. Do not set room thermostat system selector switch to "Heat" or "Auto." with gas supply line manual shut-off valve closed, or main gas valve on "Off." Manual shut-off valve must be open and main gas valve must be on "Pilot" or "On." *Otherwise, pilot glow coil will cycle unnecessarily and reduce its life.*
 3. Tape which holds condenser fan in shipping position is removed.
 4. Set heat anticipator for 0.6 amp for natural gas and 0.4 amp for LP gases.

Blower Adjustment

Adjust blower speed so that temperature rise falls within the range given in Table 2.

Fan Switch Setting

The switch can be adjusted to cut out between 80 - 120 F. For the best operation set at 90 F. The fan switch is an electric heat assist type in conjunction with the heat from the heat exchanger.

MAIN BURNERS (Refer to Fig. 6)

1. Follow steps 1 thru 6, Automatic Pilot.
2. Turn main gas valve to "On." Allow unit to operate at least 15 minutes with access panel in place.
3. Remove access panel.
4. Loosen primary air adjustment screw locknut. Turn each primary air adjustment screw clockwise until yellow tips appear on burner flames. Finally, turn each screw about 3/4 turn counterclockwise until yellow tips disappear and flames are a clear, almost transparent blue with a well defined inner cone. If flames lift off burner ports, turn screw just a little clockwise.
5. Tighten locknuts.

CHECKOUT — Move thermostat dial above and below room temperature several times, pausing at least 5 minutes between cycles. Check ignition of main burners and fan switch operation.

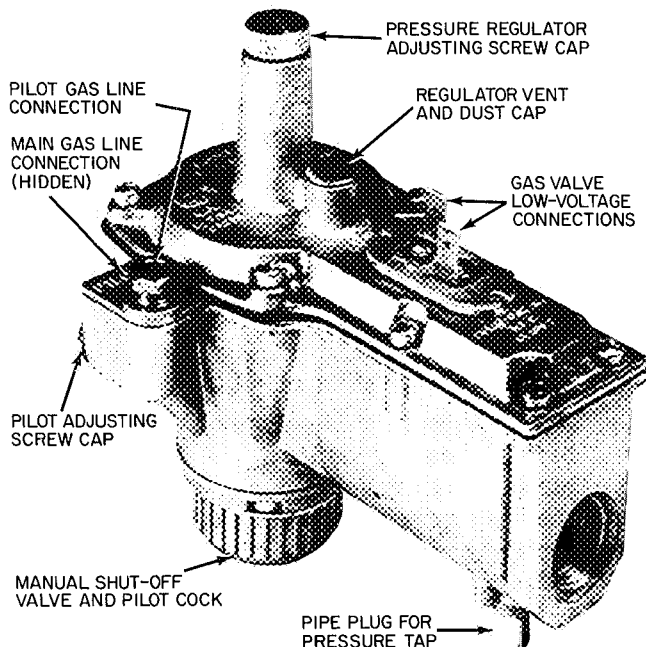

Fig. 6 — Main Gas Valve

AUTOMATIC PILOT

1. Place thermostat system selector switch to "Off" and dial setting a few degrees below room temperature.
2. Purge gas supply line by loosening pipe union, upstream of unit. Tighten when gas odor is detected.
3. Remove burner compartment access panel and wait 5 minutes before proceeding.
4. Turn main gas valve to "Pilot."
5. Place thermostat selector switch on "Heat" and dial setting a few degrees above room temperature. Pilot will automatically ignite in about 5 minutes. If ignition fails, refer to Glow Coil Pilot Ignition and Adjustment for 48DH,DL002 units only.

6. Adjust pilot flame if other than factory setting of 1-1/4 to 1-1/2 in. long. Remove pilot adjusting screw cap on main gas valve. Turn screw clockwise to increase and counterclockwise to decrease flame. Replace cap.

GLOW COIL PILOT IGNITION AND ADJUSTMENT — An automatic reset circuit breaker in glow coil circuit cycles glow coil on and off during pilot ignition. For proper operation, measure line voltage at unit. Compare measured voltage with the following ranges and cut off the amount of resistance wire indicated: above 232 v, none; 222-242 v, 12 in.; 212-232 v, 27 in.; 207-222 v, 36 inches. If voltage is in 2 bracket ranges, cut off shortest length. Wire is tagged and coiled on casing to left of gas manifold. Also, cut off one in. of resistance wire for each 2 ft of thermostat cable over 25 ft.

If other than 18-gage copper thermostat cable is used, measure resistance of one lead from unit to thermostat. Multiply resistance by 2. Cut off resistance wire one in. per 0.032 ohms to equal resistance of thermostat leads.

Example — Measured resistance .32 ohm x 2 = .64; .64 ÷ 0.032 = 20 in.; cut off 20 in. of resistance wire.

Natural Gas Units — The following sequences of operation apply to units with Model 870 solid state pilot ignition control, Therm-O-Disc electric heater assist fan control and Model A643 heat motor operated gas valve.

MANUAL SEQUENCE

1. Turn gas valve to "On" position.
2. Set thermostat to "Heat" position and thermostat dial a few degrees above room temperature.
3. Turn power "On."

AUTOMATIC SEQUENCE (immediately after power is turned on).

1. Solid State pilot relight system and fan switch heater energize.
2. Evaporator fan motor starts in 45-75 seconds.
3. Pilot glow coil energizes in 4-5 minutes.
4. Pilot flame ignites. (If gas pressure is less than 3 in. W.C., pilot may not ignite, but if air is not bled from gas line, pilot will definitely fail to ignite. The glow coil with cycle on for 10-15 seconds and off for 2.5-3.5 minutes until conditions are corrected.)
5. Glow coil de-energizes when safety pilot switch sensing element is sufficiently hot to indicate a pilot proven condition.
6. Main gas is energized.
7. Main gas valve opens in 10-15 seconds and main burner flame ignites.

8. Thermostat setting is satisfied, then main gas valve closes in 10-14 seconds.
9. Evaporator fan motor stops in 0.5-4.0 minutes. (This depends on fan control setting, firing rate, return air temperature, speed setting of motor and length of burner operation.)

L.P. Gas Units — The following sequences of operation apply to units with fan purge system, glow coil pilot ignition, Therm-O-Disc electric heater assist fan control and Robertshaw series 7000 BGVE gas valve.

MANUAL SEQUENCE

1. Turn gas valve to "On," thermostat to "Heat" and thermostat dial a few degrees above room temperature.
2. Turn power on.

AUTOMATIC SEQUENCE (immediately after power is turned on).

1. Purge system TDR (time delay relay) and FSH (fan switch heater) are energized.
2. Within 30-40 seconds TDR normally opened contacts close, and normally closed contacts open. TDR is de-energized and heater starts to cool.
3. Purge system CR (control relay) is energized, and three sets of CR contacts close.
4. Purge fan starts. Within 40-50 seconds TDR cools and contacts return to normal positions.
5. TDR is energized and circuit is completed to the pilot ignition system. (Fan switch may close during this time and evaporator fan will start.)
6. Pilot flame ignites. *(If gas pressure is less than 3 in. W.C., pilot may not ignite, but if air is not bled from gas line, pilot will definitely fail to ignite. The pilot ignition device will cycle on 30-40 seconds and off, 40-50 seconds until conditions are corrected.)*
7. Within 30-40 seconds, pilot ignition device is de-energized. (This may occur either because of pilot safety switch breaking circuit to the ignition device or TDR contacts switch.)
8. Circuit to main gas valve is energized when sensing element is sufficiently hot to ignite pilot flame.
9. Main gas valve is energized and opens. Purge fan circuit is de-energized and stops fan.
10. Main burner flame ignites.
11. Thermostat setting is satisfied, main gas valve stops and evaporator fan motor stops in 0.5-4.0 minutes later.

Operating Sequence — Heating Season

1. Pilot ignited. Thermostat selector switch on "Heat" or "Auto." Set dial above room temperature.
2. Main gas valve circuit is energized. Valve opens in 10-15 seconds. Gas flows to main burners and is ignited by pilot flame.
3. Fan switch starts indoor fan in about 1-1/2 minutes.
4. When thermostat is satisfied, main gas circuit is de-energized. Valve closes in 10-15 seconds. Gas stops flowing to main burners, extinguishing flame. Fan switch stops indoor fan at approximately 85 F bonnet temperature.
5. Limit switch shuts off unit if air circulation is restricted or fan stops. Pilot will automatically reignite if extinguished.

Operating Sequence — Cooling Season

1. Unit energized. Room thermostat selector switch on "Cool" or "Auto." Dial setting below room temperature.
2. Fans and compressor start. They stop when thermostat is satisfied.

Automatic Operation — Power and gas on. Room thermostat (control center) set at "Auto.," fan switch set at "Auto." Unit performs as described above on call for either cooling or heating. Automatic changeover type thermostat is required.

Continuous Fan Operation — (Requires field installation of accessory indoor fan relay on 002 units only.) With power to unit and fan switch on "Cont" indoor fan remains on at all times.

Complete Shutdown Or Changing From Heating To Cooling

1. Turn thermostat selector switch to "Off."
2. Remove burner compartment access panel.
3. Turn main gas valve dial to "Pilot." Depress and turn to "Off."
4. De-energize unit; replace and secure access panel.

Cooling System

1. Energize unit.
2. Set room thermostat selector switch to "Cool" or "Auto." and dial setting below room temperature.

CHECKOUT

1. Move thermostat dial above and below room temperature several times, pausing at least 5 minutes between cycles. Check compressor and fan operations.
2. Check unit operating voltage. Voltage must be within ± 10 percent nameplate voltage.
3. Check cooling effect at air outlets.
4. Check action of safety devices and controls.

Table 5 – Manifold Pressure (in. W.C.)

TYPE OF GAS	BTU PER CU FT	SP GR	UNIT								MAIN BURNER ORIFICE	PILOT ORIFICE
			48DH			48DL						
			002	004	005	002	003	004	005	005		
Natural	1000	60	3.3	3.0	3.0	3.5	3.3	3.3	3.0	3.4	#41 Drill	016 in
		.65	3.5	3.2	3.2	3.7	3.5	3.5	3.2	3.6		
	1050	60	3.0	2.7	2.7	3.2	3.0	3.0	2.7	3.1		
		.65	3.2	2.9	2.9	3.4	3.2	3.2	2.9	3.3		
	1100	60	2.7	2.4	2.4	2.9	2.7	2.7	2.4	2.8		
	.65	2.9	2.6	2.6	3.1	2.9	2.9	2.6	3.0			
Butane	3200	2.00	11.5	10.5	10.5	12.0	11.5	11.5	10.5	12.2	#54 Drill	.010 in
Propane	2500	1.53	12.2	11.2	11.2	13.0	12.2	12.2	11.2	12.9		

SERVICE

Heating System

MAIN BURNER GAS INPUT ADJUSTMENT

(Refer to Fig. 6 and Table 5 & 6) – Need for adjustment is determined by comparing measured gas input (flow rate or manifold pressure) against rated input for a specific gravity gas value (Btu per cu ft). Check with local gas supplier for value. All appliances, other than unit, must be shut down before measuring.

Flow rate (cfm), most reliable, is measured with gas meter and stop watch.

Manifold pressure (in. wg) is measured with a U-tube manometer, connected on one side to unit gas valve tap.

1. Ensure unit is shut down and gas supply line manual shut-off valve is closed. Remove gas valve tap plug and connect manometer. Open shut-off valve.
2. Start up heating system.
3. Measure gas input and compare with rated input. Refer to Table 5 & 6.
4. To adjust pressure.
 - a. Remove regulator adjusting screw cap.
 - b. Turn screw slowly, clockwise to increase, counterclockwise to decrease pressure.
 - c. Replace screw cap.
 - d. Shut down heating system.
 - e. Close gas supply line manual shut-off valve and remove manometer. Replace gas valve tap plug and open shut-off valve.
 - f. Replace burner compartment access panel.

Charging – Standard 1/4-in. Schrader service connections are provided on high and low sides of the refrigerant system for charging and evacuation. To recharge a unit, evacuate the unit and weigh in full charge stamped on serial plate. If previous charge is blown to the atmosphere, weigh in full charge less 0.15 lb. For units having partial charge use *Chargemaster*TM procedure in the following paragraphs.

Table 6 – Gas Rate CFM

UNIT	48DL	48DH	48DL	48DL	48DH	48DL	48DL	48DH
	002	002	003	004	004	005	005	005
Nat 1000	.93	1.33	1.33	1.33	1.67	1.67	1.83	2.50
Nat 1050	.89	1.27	1.27	1.27	1.59	1.59	1.74	2.38
Nat 1100	.85	1.21	1.21	1.21	1.52	1.52	1.66	2.27
Butane 3200	28	41	41	41	52	52	57	78
Propane 2500	.37	53	53	53	67	67	73	1.00

CHARGEMASTER OPERATION – Operate unit 10 minutes before using *Chargemaster* (Carrier Part No. 38GC680004).

1. Tape *Chargemaster* feeler bulb to suction line close to condensing unit. Insulate bulb. Ensure suction line is clean for good contact with bulb.
2. Connect refrigerant drum to *Chargemaster* inlet port with drum in position for vapor charging.
3. Connect *Chargemaster* outlet port to unit suction valve service port.
4. Crack valves on refrigerant drum and *Chargemaster* to purge lines from drum to suction valve. After purging lines, close valve on *Chargemaster* only.
5. Measure outdoor air dry-bulb temperature.
6. Crack unit suction valve and read *evaporator temperature at red needle position* on *Chargemaster* temperature gage and *suction line temperature at black needle position*.

CAUTION: Do not read evaporator temperature with *Chargemaster* valve open.

7. Enter Suction Line Temperature table at outdoor air temperature (step 5) and evaporator temperature (step 6). Find the suction line temperature required for correct system charge. If actual suction line temperature (step 6) is higher than table value, the system is undercharged. If suction line temperature is lower than table value, the system is overcharged.

Example: At outdoor air temperature of 85 F and evaporator temperature of 40 F, the system will be correctly charged at 71 F (± 2 F) suction line temperature.

8. Add charge by slowly opening Chargemaster™ valve. If necessary, reduce charge by bleeding at liquid line service valve. Check outdoor air and evaporator temperature during procedure. If they change, refer back to Suction Line Temperature table for new value.

Correct use of *Chargemaster* ensures an optimum refrigerant charge will be in system when conditions and system components are normal. However, the *Chargemaster* does not solve or fix system abnormalities. It indicates correct charge for condition of system. It will not make corrections for dirty filters, slow fans, excessively long or short suction lines or other abnormal conditions. This charging device ensures that a correct relationship exists between outdoor temp, evaporator temp, and suction line temp on a specific system.

Table 7 – Suction Line Temperature (F)

OUTDOOR TEMP (F)	EVAPORATOR TEMP (F)											
	28	30	32	34	36	38	40	42	44	46	48	50
60	60											
65	49	58	65									
70	41	48	58	68	70							
75	35	41	48	58	68	75						
80	31	36	42	50	59	69	80					
85		32	38	44	52	60	71	82				
90			35	40	47	53	61	69	78			
95				37	42	48	53	59	67	79		
100					39	43	47	52	58	68	88	
105						40	44	48	53	60	75	104
110							41	44	49	54	65	80
115									46	50	62	69

Example

Part Removal

EVAPORATOR FAN – To remove evaporator fan (blower) proceed as follows:

1. Loosen screws on heating access panel and remove panel.
2. On all units, except 48DH,DL002, remove upper right side screw on control box and swing control box to horizontal position.
3. Loosen (5) screws holding partition and remove partition.
4. Disconnect the two wires to fan motor and one wire to the capacitor.
5. Remove the two screws holding the evaporator fan housing to unit and slide housing and fan out of unit.

BAFFLE (EVAPORATOR HEADER) – To check for leaks at return bends, it is necessary to remove baffle as follows:

1. Remove six screws holding down condenser fan grille and orifice.
2. Lift and remove condenser fan and grille and place on top of unit. (Wiring to fan is long enough to allow removal as such.)

3. Remove top and bottom screws along baffle; remove baffle.

Spring Inspection

1. Clean indoor fan housing, cooling coil, condensate pan and drain.
2. Clean air filter and supply and return air grilles.
3. Check electrical components and connections.
4. Inspect panels and ducts for air leaks.

Fall Inspection

1. Follow steps 1 thru 4, Spring Inspection.
2. Clean and inspect pilot and main burners, heat exchangers and flues.
3. Check main gas valve operation.

Cleaning

HEAT EXCHANGER

1. Shut down unit.
2. Remove burner compartment access panel, heat shield front upper panel, flue box, and radiation baffle over burners. Preserve all gaskets.
3. Clean soot from inside of heat exchanger and other internal surfaces, especially the narrow vertical sections of tubes. Use a long wire-handled nylon-bristle brush and vacuum cleaner.
4. Reassemble unit. Avoid gasket damage.

INDOOR COIL may be cleaned with a stiff brush or vacuum cleaner.

OUTDOOR COIL – Cleaned same as indoor coil or with low-pressure steam or water.

CONDENSATE PAN AND DRAIN LINES should be cleaned once a year, preferably in spring. Drain off water in fall.

FILTERS – Inspect, clean or replace filters as conditions warrant. Never run unit without filters.

Throwaway-type filter may be cleaned by vacuum cleaning or tapping lightly over newspaper. Replace filters with the cleaner side facing downstream. Never clean filters more than once.

Permanent filters are to be cleaned according to manufacturer's instructions.

Checking Controls and Safety Devices

GAS VALVE – Refer to Start-Up, Heating System and Operating Sequence – Heating season for main gas valve and automatic pilot operation.

FAN SWITCH (temperature actuated) controls indoor fan during heating cycle and has adjustable cutout.

SOLID STATE IGNITION – If solid state ignition is suspected of being faulty, *do not attempt to repair*. Replace complete ignition unit with another.

Lubricating

FAN MOTOR BEARINGS are factory lubricated and require no service for 3 to 5 years, depending on usage. Then, clean and relubricate per motor manufacturers' directions. Light to medium duty automotive-type nondetergent oil is satisfactory.

COMPRESSOR has its own oil supply. If oil is lost due to a leak in the system, refer to Carrier's Standard Service Techniques Manual, Chapter 1, Refrigerant.

See Carrier's Standard Service Techniques Manual, Chapter 2, Electrical, to check necessary electrical components. Also, see Troubleshooting section for heating and cooling.

CAUTION: Pressure relief (200 F fusible plug located in suction line) should be covered with a wet rag if any soldering or brazing is to be done near it.

TROUBLESHOOTING FOR HEATING

Burner Will Not Operate

Power failure – Power switch off, blown line fuse, defective wiring

No power to controls – thermostat set too low, dirty or defective; defective transformer; faulty limit switch, blown fusestat.

Burner will not ignite – no gas to unit; faulty valve or pilot switch; faulty glow coil; dirty pilot.

Burner Operates, But Heating Inadequate

Unit undersized – unit size selected incorrectly.

Fuel input too low – wrong orifice size; regulator set too low.

Thermostat opens too soon – wrong anticipator setting, thermostat out of calibration; wrong thermostat location; thermostat set wrong.

Limit switch cycles burner – dirty filters; faulty fan switch or motor; limit switch set wrong; duct system restricted.

Poor Combustion and Flame Characteristics

Smoky flame – insufficient air; flue restriction.

Noisy burner – too much air; incorrect input.

TROUBLESHOOTING FOR COOLING

Compressor Will Not Start

Power failure – power switch off; blown line fuse; defective wiring.

No power to controls – thermostat set too low, dirty or defective, defective transformer; contactor coil open; loose leads from closed contactor.

Power to compressor – motor windings open; contactor closes then opens.

Compressor Runs But Insufficient Cooling

Low suction pressure – restricted air flow; capillary tubes restricted; low refrigerant charge.

Low head and high suction pressure – defective compressor valves.

Indoor fan stopped – loose or broken leads, faulty capacitor, internal short circuit.

Compressor Will Not Restart

Power failure – power switch off, blown line fuse.

Power at closed contactor – faulty start relay or capacitor (if used), contactor, run capacitor or compressor.

Cycles On Overload

Insufficient condenser air – check condenser fan position in reference to orifice as in Fig. 7.

Condenser air restricted – dirty coil; air flow restricted.

Condenser air recirculating – obstruction deflecting air flow.

Improper line voltage – circuit overloaded; loose electrical connections.

Faulty run capacitor – capacitor shorted or low on capacitance (mfd).

Noncondensables in system – moisture or air in system.

System overcharged – excessive refrigerant.

No refrigerant in system – leak in system.

System restricted – capillary tubes restricted or plugged, kinked tubing.

Fan slipping on motor shaft – setscrews either loose or missing from fan.

Fan motor bearing seized – lack of oil or bearing failure.

Fan motor defective – internal short circuit.

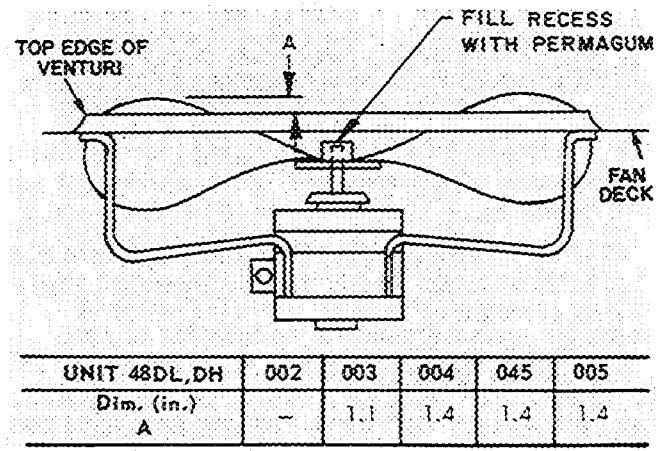

Fig. 7 – Outdoor Fan Clearance

For replacement items use Carrier Specified Parts.

Manufacturer reserves the right to change any product specifications without notice.

CARRIER AIR CONDITIONING COMPANY • SYRACUSE, NEW YORK