

Digital Video Camera Recorder  
**HANDYCAM®**

## Operating Guide

### **DCR-HC28**

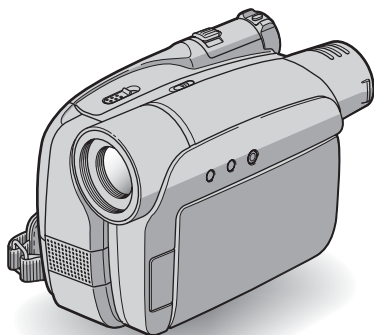

Getting Started **11**

 Recording/  
Playback **22**

Using the Menu **34**

Dubbing/Editing **48**

Troubleshooting **54**

Additional Information **64**

Spanish Quick Guide/  
Guía rápida en español **77**

## WARNING

To reduce fire or shock hazard, do not expose the unit to rain or moisture.

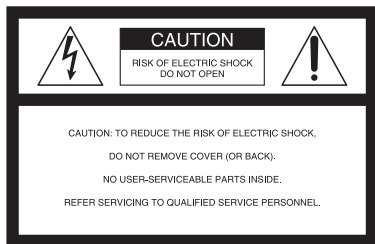

This symbol is intended to alert the user to the presence of uninsulated “dangerous voltage” within the product’s enclosure that may be of sufficient magnitude to constitute a risk of electric shock to persons.



This symbol is intended to alert the user to the presence of important operating and maintenance (servicing) instructions in the literature accompanying the appliance.

# IMPORTANT SAFEGUARDS

For your protection, please read these safety instructions completely before operating the appliance, and keep this manual for future reference.

Carefully observe all warnings, precautions and instructions on the appliance, or the one described in the operating instructions and adhere to them.

## Use

### Power Sources

This set should be operated only from the type of power source indicated on the marking label. If you are not sure of the type of electrical power supplied to your home, consult your dealer or local power company. For those sets designed to operate from battery power, or other sources, refer to the operating instructions.

### Polarization

This set may be equipped with a polarized ac power cord plug (a plug having one blade wider than the other).

This plug will fit into the power outlet only one way. This is a safety feature. If you are unable to insert the plug fully into the outlet, try reversing the plug. If the plug should still fail to fit, contact your electrician to have a suitable outlet installed. Do not defeat the safety purpose of the polarized plug by forcing it in.

### Overloading

Do not overload wall outlets, extension cords or convenience receptacles beyond their capacity, since this can result in fire or electric shock.

### Object and Liquid Entry

Never push objects of any kind into the set through openings as they may touch dangerous voltage points or short out parts that could result in a fire or electric shock. Never spill liquid of any kind on the set.

### Attachments

Do not use attachments not recommended by the manufacturer, as they may cause hazards.

## Cleaning

Unplug the set from the wall outlet before cleaning or polishing it. Do not use liquid cleaners or aerosol cleaners. Use a cloth lightly dampened with water for cleaning the exterior of the set.

## Installation

### Water and Moisture

Do not use power-line operated sets near water – for example, near a bathtub, washbowl, kitchen sink, or laundry tub, in a wet basement, or near a swimming pool, etc.

### Power-Cord Protection

Route the power cord so that it is not likely to be walked on or pinched by items placed upon or against them, paying particular attention to the plugs, receptacles, and the point where the cord exits from the appliance.

### Accessories

Do not place the set on an unstable cart, stand, tripod, bracket, or table. The set may fall, causing serious injury to a child or an adult, and serious damage to the set. Use only a cart, stand, tripod, bracket, or table recommended by the manufacturer.

### Ventilation

The slots and openings in the cabinet are provided for necessary ventilation. To ensure reliable operation of the set, and to protect it from overheating, these slots and openings must never be blocked or covered.

- Never cover the slots and openings with a cloth or other materials.
- Never block the slots and openings by placing the set on a bed, sofa, rug, or other similar surface.
- Never place the set in a confined space, such as a bookcase, or built-in cabinet, unless proper ventilation is provided.
- Do not place the set near or over a radiator or heat register, or where it is exposed to direct sunlight.

## IMPORTANT SAFEGUARDS (Continued)

### Lightning

For added protection for this set during a lightning storm, or when it is left unattended and unused for long periods of time, unplug it from the wall outlet and disconnect the antenna or cable system. This will prevent damage to the set due to lightning and power-line surges.

## Service

### Damage Requiring Service

Unplug the set from the wall outlet and refer servicing to qualified service personnel under the following conditions:

- When the power cord or plug is damaged or frayed.
- If liquid has been spilled or objects have fallen into the set.
- If the set has been exposed to rain or water.
- If the set has been subject to excessive shock by being dropped, or the cabinet has been damaged.
- If the set does not operate normally when following the operating instructions. Adjust only those controls that are specified in the operating instructions. Improper adjustment of other controls may result in damage and will often require extensive work by a qualified technician to restore the set to normal operation.
- When the set exhibits a distinct change in performance – this indicates a need for service.

### Servicing

Do not attempt to service the set yourself as opening or removing covers may expose you to dangerous voltage or other hazards.

Refer all servicing to qualified service personnel.

### Replacement parts

When replacement parts are required, be sure the service technician has used replacement parts specified by the manufacturer that have the same characteristics as the original parts.

Unauthorized substitutions may result in fire, electric shock, or other hazards.

### Safety Check

Upon completion of any service or repairs to the set, ask the service technician to perform routine safety checks (as specified by the manufacturer) to determine that the set is in safe operating condition.

# Read this first

Before operating the unit, please read this manual thoroughly, and retain it for future reference.

## CAUTION

**Replace the battery with the specified type only. Otherwise, fire or injury may result.**

## For customers in the U.S.A. and CANADA

### RECYCLING LITHIUM-ION BATTERIES

Lithium-Ion batteries are recyclable. You can help preserve our environment by returning your used rechargeable batteries to the collection and recycling location nearest you.

For more information regarding recycling of rechargeable batteries, call toll free 1-800-822-8837, or visit <http://www.rbrcc.org/>

Caution: Do not handle damaged or leaking Lithium-Ion batteries.

### Battery pack

This device complies with Part 15 of the FCC Rules. Operation is subject to the following two conditions:

(1) This device may not cause harmful interference, and (2) this device must accept any interference received, including interference that may cause undesired operation.

This Class B digital apparatus complies with Canadian ICES-003.



## For customers in the U.S.A.

If you have any questions about this product, you may call:  
Sony Customer Information Center 1-800-222-SONY (7669).

The number below is for the FCC related matters only.

### Regulatory Information

#### Declaration of Conformity

Trade Name: SONY

Model No.: DCR-HC28

Responsible Party: Sony Electronics Inc.

Address: 16530 Via Esprillo, San Diego, CA 92127 U.S.A.

Telephone Number: 858-942-2230

This device complies with Part 15 of the FCC Rules.

Operation is subject to the following two conditions:

(1) This device may not cause harmful interference, and (2) this device must accept any interference received, including interference that may cause undesired operation.

### CAUTION

You are cautioned that any changes or modifications not expressly approved in this manual could void your authority to operate this equipment.

### Note

This equipment has been tested and found to comply with the limits for a Class B digital device, pursuant to Part 15 of the FCC Rules.

These limits are designed to provide reasonable protection against harmful interference in a residential installation. This equipment generates, uses, and can radiate radio frequency energy and, if not installed and used in accordance with the instructions, may cause harmful interference to radio communications.

## Read this first (Continued)

However, there is no guarantee that interference will not occur in a particular installation. If this equipment does cause harmful interference to radio or television reception, which can be determined by turning the equipment off and on, the user is encouraged to try to correct the interference by one or more of the following measures:

- Reorient or relocate the receiving antenna.
- Increase the separation between the equipment and receiver.
- Connect the equipment into an outlet on a circuit different from that to which the receiver is connected.
- Consult the dealer or an experienced radio/TV technician for help.

The supplied interface cable must be used with the equipment in order to comply with the limits for a digital device pursuant to Subpart B of Part 15 of FCC Rules.

### Owner's Record

The model and serial numbers are located on the bottom. Record the serial number in the space provided below. Refer to these numbers whenever you call your Sony dealer regarding this product.

Model No. DCR-HC28

Serial No. \_\_\_\_\_

Model No. AC- \_\_\_\_\_

Serial No. \_\_\_\_\_

### For the State of California, USA only

Perchlorate Material - special handling may apply, See

[www.dtsc.ca.gov/hazardouswaste/perchlorate](http://www.dtsc.ca.gov/hazardouswaste/perchlorate)

Perchlorate Material: Lithium battery contains perchlorate.

### Notes on use

#### Types of cassette you can use in your camcorder

- You can use mini DV cassettes marked with <sup>Mini</sup> **DV**. Your camcorder is not compatible with the Cassette Memory function (p. 65).

### Using the camcorder

- Do not hold the camcorder by the following parts.

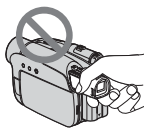

Viewfinder



Battery pack

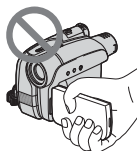

LCD panel

- The camcorder is not dustproof, dripproof or waterproof. See "Maintenance and precautions" (p. 68).
- Before connecting your camcorder to another device with an i.LINK cable, be sure to insert the connector plug the correct way, and not forcibly to avoid damaging the terminal, or cause a malfunction of your camcorder.

### About menu items, LCD panel, viewfinder, and lens

- A menu item that is grayed out is not available under the current recording or playback conditions.

- The LCD screen and the viewfinder are manufactured using extremely high-precision technology, so over 99.99% of the pixels are operational for effective use. However, there may be some tiny black points and/or bright points (white, red, blue, or green in color) that appear constantly on the LCD screen and the viewfinder. These points are normal results of the manufacturing process and do not affect the recording in any way.

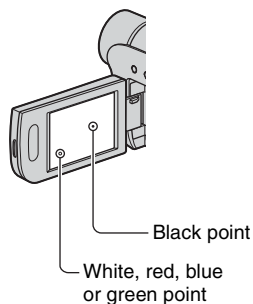

- Exposing the LCD screen, the viewfinder, or the lens to direct sunlight for long periods of time may cause malfunctions.
- Do not aim at the sun. Doing so might cause your camcorder to malfunction. Take pictures of the sun only in low light conditions, such as at dusk.

## On recording

- Before starting to record, test the recording function to make sure the picture and sound are recorded without any problems.
- Compensation for the contents of recordings cannot be provided, even if recording or playback is not possible due to a malfunction of the camcorder, storage media, etc.
- TV color systems differ depending on the countries/regions. To view your recordings on a TV, you need an NTSC system-based TV.

- Television programs, films, video tapes, and other materials may be copyrighted. Unauthorized recording of such materials may be contrary to the copyright laws.

## About this manual

- The images of the LCD screen and the viewfinder used in this manual for illustration purposes are captured using a digital still camera, and therefore may appear different.
- The on-screen displays in each local language are used for illustrating the operating procedures. Change the screen language before using your camcorder if necessary (p. 17).
- Design and specifications of recording media and accessories are subject to change without notice.

## About the Carl Zeiss lens

Your camcorder is equipped with a Carl Zeiss lens, which was developed jointly by Carl Zeiss, in Germany, and Sony Corporation, and produces superior images. It adopts the MTF\* measurement system for video cameras and offers a quality typical of a Carl Zeiss lens.

\* MTF stands for Modulation Transfer Function. The number value indicates the amount of light from a subject coming into the lens.

# Table of Contents

IMPORTANT SAFEGUARDS .....	3
Read this first .....	5

## Getting Started

Step 1: Checking supplied items .....	11
Step 2: Charging the battery pack .....	12
Step 3: Turning the power on and holding your camcorder firmly .....	15
Step 4: Adjusting the LCD panel and viewfinder .....	16
Step 5: Using the touch panel .....	17
Changing the language setting .....	17
Checking the screen indicators (Display guide) .....	17
Step 6: Setting the date and time .....	19
Step 7: Inserting a Cassette .....	20









## Recording/Playback

Easy Recording/Playback (Easy Handycam) .....	22
Recording .....	24
Playback .....	25
Functions used for recording/playback, etc. ....	26
<b>Recording</b>	
To use zoom	
To record in dark places (NightShot plus)	
To adjust the exposure for backlit subjects (BACK LIGHT)	
To adjust the focus for an off center subject (SPOT FOCUS)	
To fix the exposure for the selected subject (Flexible spot meter)	
To record in mirror mode	
To use a tripod	
To use a Shoulder Belt	
<b>Playback</b>	
To play back the images with added special effects (Picture effect)	
<b>Recording/playback</b>	
To check the remaining battery (Battery Info)	
To turn off the operation confirmation beep (BEEP)	
To initialize the settings (RESET)	
Other part names and functions	
Indicators displayed during recording/playback .....	28
Searching for the starting point .....	30
Searching for the last scene of the most recent recording (END SEARCH) .....	30
Searching manually (EDIT SEARCH) .....	30



Reviewing the most recently recorded scenes (Rec review) .....	31
Playing the picture on a TV .....	32

## Using the Menu

<i>Using the menu items</i> .....	34
Operation button items .....	36
Menu items .....	41
 MANUAL SET menu .....	42
– PROGRAM AE/P EFFECT, etc.	
 CAMERA SET menu .....	43
– D ZOOM/WIDE SEL/STEADYSHOT, etc.	
 VCR SET menu .....	45
– AUDIO MIX	
 LCD/VF SET menu .....	45
– LCD B.L./LCD COLOR/VF B.L., etc	
 TAPE SET menu .....	46
– REC MODE/AUDIO MODE/REMAIN	
 SETUP MENU menu .....	47
– CLOCK SET/LANGUAGE, etc.	
 OTHERS menu .....	47
– WORLD TIME/BEEP, etc.	

## Dubbing/Editing

Dubbing to VCR/DVD device, etc. ....	48
Recording pictures from a TV or VCR/DVD device, etc. ....	50
Dubbing sound to a recorded tape .....	51
Jacks to connect external devices .....	53

## Troubleshooting

Troubleshooting .....	54
Warning indicators and messages .....	61

## Additional Information

Using your camcorder abroad .....	64
Usable cassette tapes .....	65
About the “InfoLITHIUM” battery pack .....	66
About i.LINK .....	67
Maintenance and precautions .....	68
Specifications .....	71
Index .....	74

## Spanish Quick Guide/Guía rápida en español

77

## Step 1: Checking supplied items

Make sure that you have following items supplied with your camcorder. The number in the parentheses indicates the number of that item supplied.

AC Adaptor (1) (p. 12)

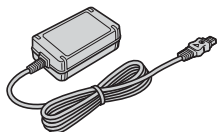

Power cord (1) (p. 12)



A/V connecting cable (1) (p. 32, 48)



Lens cap (1) (p. 15, 24)



- To attach the lens cap

Attach the lens cap to the metal fittings of the grip belt, as illustrated below, using the strap.

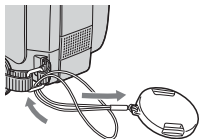

Rechargeable battery pack NP-FP30 (1)  
(p. 12, 66)

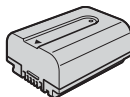

Operating Guide (This manual) (1)

## Step 2: Charging the battery pack

You can charge the “InfoLITHIUM” battery pack (P series/H series) (p. 66) after attaching it to your camcorder.

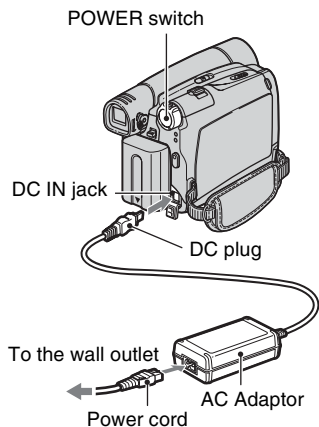

**1** Align the terminals of the battery pack and your camcorder ①, then attach the battery pack and click it into place ②.

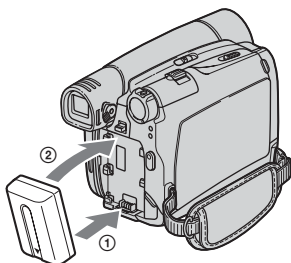

**2** Slide the POWER switch in the direction of the arrow to OFF(CHG) (The default setting).

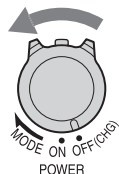

**3** Connect the AC Adaptor to the DC IN jack on your camcorder.

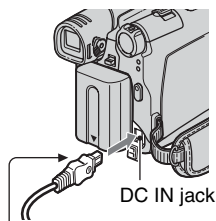

With the ▲ mark facing to the LCD screen

**4** Connect the power cord to the AC Adaptor and the wall outlet.

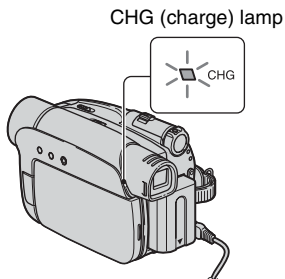

The CHG (charge) lamp lights up and charging starts.

## 5 The CHG (charge) lamp turns off when the battery is fully charged. Disconnect the AC Adaptor from the DC IN jack.

Disconnect the AC Adaptor from the DC IN jack holding both the camcorder and the DC plug.

### To use an outside power source

You can operate your camcorder using the power from the wall outlet by making the same connections as you do when charging the battery pack. The battery pack will not lose its charge in this case.

### To remove the battery pack

- Slide the POWER switch to OFF(CHG). Hold down the ▼ BATT(battery) release lever with one hand.
- Remove the battery in the direction of the arrow with the other hand.

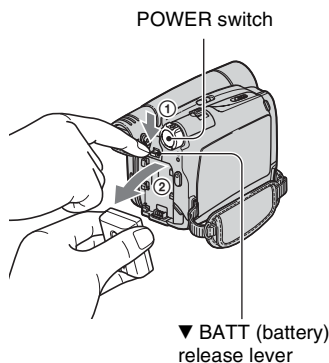

### When storing the battery pack

Fully discharge the battery before storing it for an extended period (p. 66).

### Charging time

Approximate time (min.) required when you fully charge a fully discharged battery pack.

Battery pack	Charging time
NP-FP30 (supplied)	115
NP-FP50	125
NP-FP71	170
NP-FP90	220
NP-FH50	135
NP-FH70	170
NP-FH100	390

### Recording time

Approximate time (min.) available when you use a fully charged battery pack.

Battery pack	Continuous recording time	Typical recording time*
NP-FP30 (supplied)	95	45
	110	55
NP-FP50	135	65
	160	80
NP-FP71	330	165
	395	195
NP-FP90	500	250
	580	290
NP-FH50	155	75
	180	90
NP-FH70	330	165
	395	195
NP-FH100	760	380
	890	445

- All times measured under the following conditions:  
Top: Recording with LCD screen.  
Bottom: Recording with viewfinder while the LCD panel closed.

\* Typical recording time shows the time when you repeat recording start/stop, turning the power on/off and zooming.

## Step2: Charging the battery pack (Continued)

### Playing time

Approximate time (min.) available when you use a fully charged battery pack.

Battery pack	LCD panel opened	LCD panel closed
NP-FP30 (supplied)	105	135
NP-FP50	150	190
NP-FP71	370	465
NP-FP90	550	705
NP-FH50	170	220
NP-FH70	370	465
NP-FH100	845	1065

### On the battery pack

- Before changing the battery pack, slide the POWER switch to OFF(CHG).
- The CHG (charge) lamp flashes during charging, or the Battery Info (p. 27) will not be correctly displayed under the following conditions.
  - The battery pack is not attached correctly.
  - The battery pack is damaged.
  - The battery pack is worn-out. (For Battery Info only.)
- The power will not be supplied from the battery as long as the AC Adaptor is connected to the DC IN jack of your camcorder, even when the power cord is disconnected from the wall outlet.

### On the charging/recording/playback time

- Times measured with the camcorder at 25 °C (77 °F). (10 °C to 30 °C (50 °F to 86 °F) is recommended.)
- The recording and playback time will be shorter when you use your camcorder in low temperatures.
- The recording and playback time will be shorter depending on the conditions under which you use your camcorder.

### On the AC Adaptor

- Use the nearby wall outlet when using the AC Adaptor. Disconnect the AC Adaptor from the wall outlet immediately if any malfunction occurs while using your camcorder.
- Do not use the AC Adaptor placed in a narrow space, such as between a wall and furniture.

- Do not short-circuit the DC plug of the AC Adaptor or battery terminal with any metallic objects. This may cause a malfunction.

### PRECAUTION

- Even if your camcorder is turned off, AC power (house current) is still supplied to it while connected to the wall outlet via the AC Adaptor.

# Step 3: Turning the power on and holding your camcorder firmly

To record or play back, slide the POWER switch repeatedly to turn on the respective lamp.

When using it for the first time, the [CLOCK SET] screen appears (p. 19).

POWER switch      Lens cap

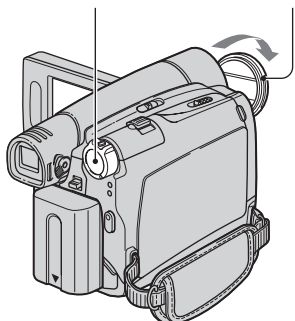

**1** Remove the lens cap by pressing both knobs on the sides of the cap.

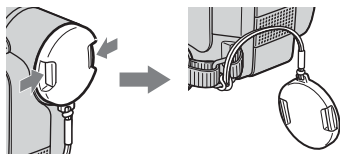

**2** Slide the POWER switch repeatedly in the direction of the arrow to turn on the respective lamp.

If the POWER switch is set to OFF(CHG), slide it while pressing the green button.

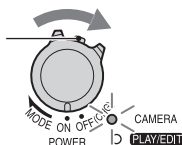

## Lamps that light up

**CAMERA:** To record on a tape.

**PLAY/EDIT:** To play or edit pictures.

- After you have set the date and time ([CLOCK SET], p. 19), the next time you turn on the power of your camcorder, the current date and time will be displayed on the LCD screen for a few seconds.

**3** Hold the camcorder correctly.

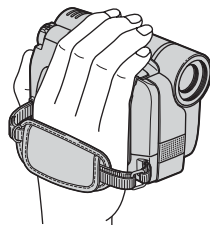

**4** Ensure a good grip, then fasten the grip belt.

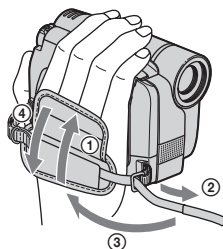

## To turn off the power

- ① Slide the POWER switch to OFF(CHG).
- ② Attach the lens cap.

- At the time of purchase, the power will be set to turn off automatically if you leave your camcorder without any operation attempted for approximately 5 minutes, to save battery power ([A.SHUT OFF], p. 47).

# Step 4: Adjusting the LCD panel and viewfinder

## The LCD panel

Open the LCD panel 90 degrees to the camcorder (①), then rotate it to the best angle to record or play (②).

180 degrees  
(max.)

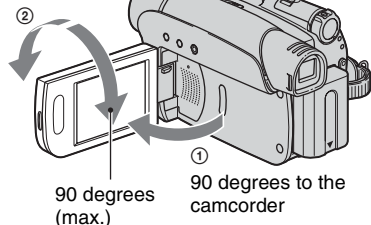

- If you rotate the LCD panel 180 degrees to the lens side, you can close the LCD panel with the LCD screen facing out. This is convenient during playback operations.
- See [LCD BRT] (p. 39) to adjust the brightness of the LCD screen.

## The viewfinder

You can view pictures using the viewfinder to avoid wearing down the battery, or when the picture seen on the LCD screen is poor.

Viewfinder

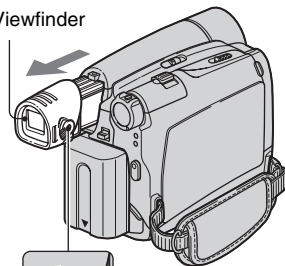

Viewfinder lens  
adjustment lever  
Move it until the picture is  
clear.

- You can adjust the brightness of the viewfinder backlight by selecting [VF B.L.] (LCD/VF SET) - [VF B.L.] (p. 46).
- You can adjust the [FADER] and the [EXPOSURE] setting using the viewfinder (p. 37).



## Step 5: Using the touch panel

You can play back recorded pictures (p. 25), or change the settings (p. 34) using the touch panel.

**Place your hand on the rear side of the LCD panel to support it. Then, touch the buttons displayed on the screen.**

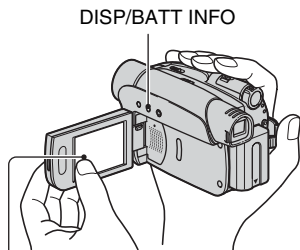



Touch the button on the LCD screen.

- If the buttons on the touch panel do not work correctly, adjust the LCD screen (CALIBRATION) (p. 70).
- Dots in lines may appear on the LCD screen, but this is not a malfunction. These dots are not recorded.

### To hide the screen indicators

Press DISP/BATT INFO to toggle the screen indicators (such as time code) on or off.

### Changing the language setting

You can change the on-screen displays to show messages in a specified language. Select the screen language in [  LANGUAGE] on the [  (SETUP MENU) (p. 34, 47).

### Checking the screen indicators (Display guide)

You can easily check the meaning of each indicator (p. 29) that appears on the LCD screen.

#### 1 Touch .

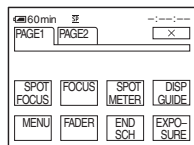

#### 2 Touch [DISP GUIDE].

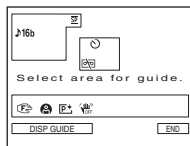

The indicators vary depending on the settings.

### 3 Touch the area including the indicator that you want to check.

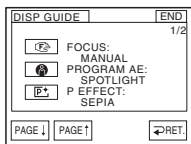

The meanings of the indicators in the area are listed on the screen. If you cannot find the indicator you want to check, touch [PAGE ↓]/[PAGE ↑] to toggle.

When you touch [RET.], the screen returns to the area selecting display.

---

### To finish the operation

Touch [END].

# Step 6: Setting the date and time

Set the date and time when using this camcorder for the first time. If you do not set the date and time, the [CLOCK SET] screen appears every time you turn on your camcorder or change the POWER switch position.

- If you do not use your camcorder for **about 3 months**, the built-in rechargeable battery gets discharged and the date and time settings may be cleared from the memory. In that case, charge the rechargeable battery and then set the date and time again (p. 71).

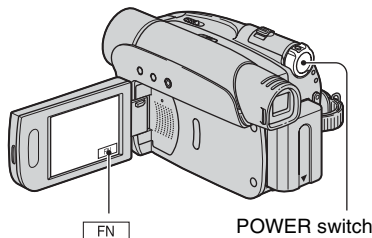

Skip to step 4 when you set the clock for the first time.

## 1 Touch **FN** → [MENU].

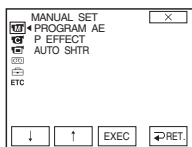

## 2 Select **(SETUP MENU)** with **↓ / ↑**, then touch [EXEC].

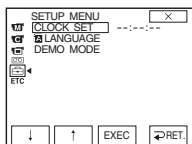

## 3 Select [CLOCK SET] with **↓ / ↑**, then touch [EXEC].

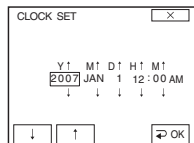

## 4 Set [Y] (year) with **↓ / ↑**, then touch **OK**.

You can set any year up to the year 2079.

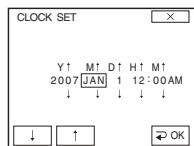

## 5 Set [M] (month), then touch **OK** and repeat for [D] (day), [H] (hour) and [M] (minute).

For midnight, set it to 12:00 AM.

For midday, set it to 12:00 PM.

The clock starts.

- The date and time are not displayed while recording, but they are automatically recorded on the tape, and can be displayed during playback (see page 39 for [DATA CODE] (During Easy Handycam operation, you can set only [DATE/TIME])).

# Step 7: Inserting a Cassette

You can use mini DV **Mini DV** cassettes only (p. 65).

- The recordable time varies depending on [REC MODE] (p. 46).

- 
- 1** Slide and hold the  OPEN/EJECT lever in the direction of the arrow and open the lid.

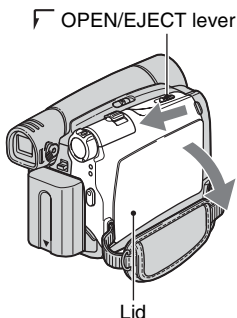

The cassette compartment automatically comes out and opens up.

- 
- 2** Insert a cassette with its window facing outwards, then press .

Push the center of the back of the cassette lightly.

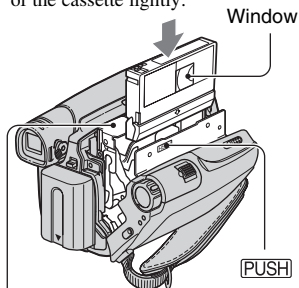

Cassette compartment

**The cassette compartment automatically slides back in.**

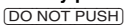
- Do not force the cassette compartment closed by pressing the portion marked  while it is sliding in. It may cause a malfunction.

- 
- 3** Close the lid.
- 

## To eject the cassette

Open the lid following the same procedure as described in step 1 and remove the cassette.





# Easy Recording/Playback (Easy Handycam)

With this Easy Handycam operation, most of the camera settings are automatically optimally adjusted, which frees you from detailed adjustments. The screen font size increases for easy viewing.

Remove the lens cap (p. 15).

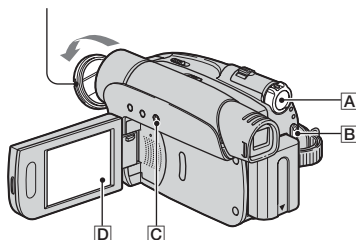

## Recording

- Slide the **POWER** switch **A** in the direction of the arrow repeatedly to turn on the **CAMERA** lamp.

If the **POWER** switch **A** is set to OFF(CHG), slide it while pressing the green button.

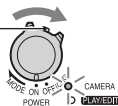

- Press **EASY** **C**.



**EASY** appears on the screen **D**.

- Press **REC START/STOP** **B** to start recording.\*

The indicator **A** changes [STBY] to [REC].  
To stop recording, press **B** again.

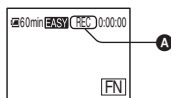

\* Movies are recorded in SP (Standard Play) mode on a cassette.

## Playback

Slide the **POWER** switch **[A]** in the direction of the arrow repeatedly to turn on the **PLAY/EDIT** lamp. Touch the buttons on the screen **[D]** as follows.

If the **POWER** switch is set to **OFF(CHG)**, slide it while pressing the green button.

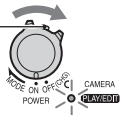

Touch **[◀◀(B)]**, then touch **[▶▶(C)]** to start playback.

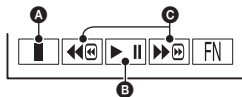

- A** Stop
- B** Play/Pause toggles as you touch it
- C** Rewind/Fast forward

### ■ To cancel Easy Handycam operation

Press **EASY** **[C]** again. **EASY** disappears from the screen **[D]**.

### ■ Adjustable menu settings during Easy Handycam operation

Touch **[FN]** and **[MENU]** to display adjustable menu settings. See page 34 for details on setting.

- Almost all the settings return to the default setting automatically (p. 41).
- Cancel Easy Handycam operation if you want to add any effects or settings to the images. Almost all the settings are returned to the previous situation.

### ■ Unavailable buttons during Easy Handycam

During Easy Handycam operation, the **BACK LIGHT** button (p. 26) is unavailable. [Invalid during Easy Handycam operation.] appears if operations not available during Easy Handycam are attempted.

# Recording

## Lens cap

Remove the lens cap by pressing both knobs on the sides of the cap

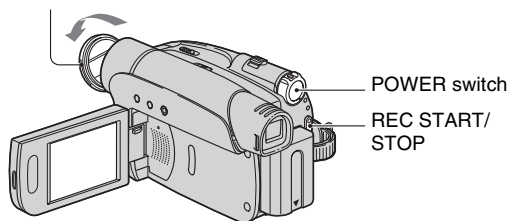

- 1** Slide the **POWER** switch in the direction of the arrow repeatedly to turn on the **CAMERA** lamp.

If the **POWER** switch is set to **OFF(CHG)**, slide it while pressing the green button.

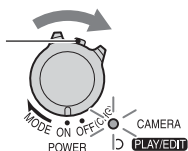

- 2** Press **REC START/STOP** to start recording.

The indicator (A) changes [STBY] to [REC].



## To stop movie recording

Press **REC START/STOP** again.



# Playback

- 1 Slide the **POWER** switch in the direction of the arrow repeatedly to turn on the **PLAY/EDIT** lamp.

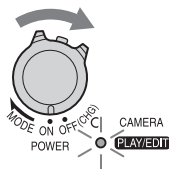

- 2 Start playing back.

Touch to rewind the tape to the desired point, then touch to start playback.

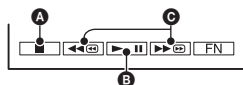

- A Stop
- B Play/Pause toggles as you touch it
  - Playback automatically stops if pause is engaged for more than 3 minutes.
- C Rewind/Fast forward

## To adjust the volume

Touch → [PAGE1] → [VOL], then / to adjust the volume.

## To search for a scene during playback

Touch and hold / during playback (Picture Search), or / while fast forwarding or rewinding the tape (Skip Scan).

- You can play back in various modes ([V SPD PLAY], p. 40).

# Functions used for recording/playback, etc.

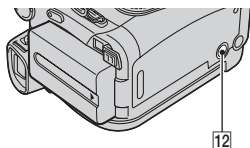
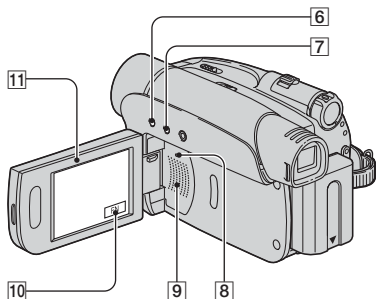
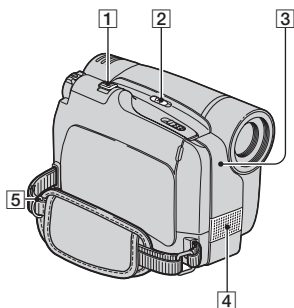

## Recording

### To use zoom ..... 1

Move the power zoom lever **1** slightly for a slower zoom. Move it further for a faster zoom.

### Wider range of view: (Wide angle)

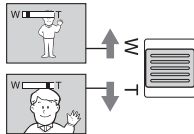

### Close view: (Telephoto)

- The minimum possible distance between camcorder and subject while maintaining sharp focus is about 1 cm (about 13/32 in.) for wide angle and about 80 cm (about 2 5/8 feet) for telephoto.
- You can set [D ZOOM] (p. 43) if you want to zoom to a level greater than 20 x.
- Be sure to keep your finger on the power zoom lever. If you move your finger off the power zoom lever, the operation sound of the power zoom lever may also be recorded.
- [STEADYSHOT] may not reduce image blurring as desired when the power zoom lever is set to the T (Telephoto) side.

### To record in dark places (NightShot plus) ..... 2

Set the NIGHTSHOT PLUS switch **2** to ON. (☑ and ["NIGHTSHOT PLUS"] appear.)

- The NightShot plus function uses infrared light. Therefore, do not cover the infrared port **3** with your fingers or other objects. Remove the conversion lens (optional) if it is attached.
- Adjust the focus manually ([FOCUS], p. 36) when it is hard to focus automatically.
- Do not use these functions in bright places. This may cause a malfunction.

### To adjust the exposure for backlit subjects (BACK LIGHT) ..... 6

To adjust the exposure for backlit subjects, press BACK LIGHT **6** to display ☑. To cancel the back light function, press BACK LIGHT again.

**To adjust the focus for an off center subject (SPOT FOCUS) ..... 10**

See [SPOT FOCUS] on page 36.

**To fix the exposure for the selected subject (Flexible spot meter) ..... 10**

See [SPOT METER] on page 36.

**To record in mirror mode ..... 11**

Open the LCD panel 11 90 degrees to the camcorder (1), then rotate it 180 degrees to the lens side (2).

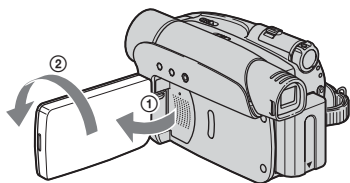

- A mirror-image of the subject appears on the LCD screen, but the picture will be normal when recorded.

**To use a tripod ..... 12**

Attach the tripod (optional: the length of the screw must be less than 5.5 mm (7/32 in.)) to the tripod receptacle 12 using a tripod screw.

**To use a Shoulder Belt ..... 5**

Attach the Shoulder Belt (optional) to its designated hook 5.

## Playback

**To play back the images with added special effects (Picture effect) .... 10**

See [P EFFECT] on page 42.

## Recording/playback

**To check the remaining battery (Battery Info) ..... 7**

Set the POWER switch to OFF(CHG), then press DISP/BATT INFO 7. The battery information appears for about 7 seconds. You can view the battery information for up to 20 seconds by pressing DISP/BATT INFO again while the battery information is displayed.

Remaining battery (approx.)

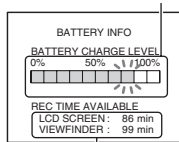

Recording capacity (approx.)

**To turn off the operation confirmation beep (BEEP) ..... 10**

See [BEEP] on page 47.

**To initialize the settings (RESET) ..... 8**

Press RESET 8 to initialize all the settings, including the setting of the date and time.

## Other part names and functions

4 Internal stereo microphone

9 Speaker

Playback sound comes out from the speaker.

- For how to adjust the volume, see page 25.

# Indicators displayed during recording/playback

## Recording

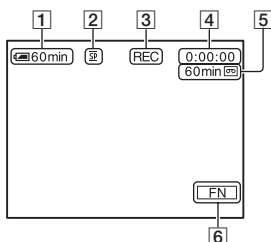

- 1 Remaining battery (approx.)
- 2 Recording mode (SP or LP) (46)
- 3 Recording status ([STBY] (standby) or [REC] (recording))
- 4 Recording: Tape counter (hour: minute: second)  
Playback: Time code (hour: minute: second: frame)
- 5 Recording capacity of the tape (approx.) (46)
- 6 Function button (34)

## Viewing

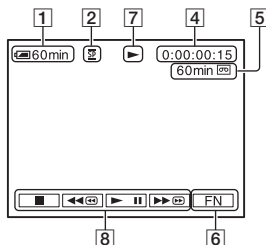

- 7 Tape transport indicator
- 8 Video operation buttons (25)

## Data code during recording

The date/time during recording and the camera setting data will be recorded automatically. They do not appear on the screen during recording, but you can check them as [DATA CODE] during playback (p. 39).

( ) is a reference page.

The indicators during recording will not be recorded.

## Indicators when you made changes

You can use [DISP GUIDE] (p. 17) to check the function of each indicator that appears on the LCD screen.

- Some of the indicators may not appear when you use [DISP GUIDE].

Upper left

Upper right

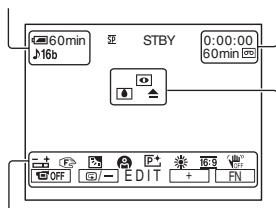

Bottom

Center

### Upper left

Indicator	Meaning
16b	AUDIO MODE (46)

### Upper right

Indicator	Meaning
DV IN	DV input (50)

### Center

Indicator	Meaning
NightShot plus	NightShot plus (26)
Warning	Warning (61)

### Bottom

Indicator	Meaning
	Flexible spot meter (36)/ Manual exposure (38)
	Manual focus (36)
	Backlight (26)
	PROGRAM AE (42)
	Picture effect (42)
	White balance (38)
	Wide select (44)
	SteadyShot off (44)
	Panel off (37)
	EDITSEARCH (44)

# Searching for the starting point

Make sure that the CAMERA lamp lights up (p. 24).

## Searching for the last scene of the most recent recording (END SEARCH)

[END SCH] (END SEARCH) will not work once you eject the cassette after you have recorded on the tape.

Touch **[FN]** → **[PAGE1]**, then touch **[END SCH]**.

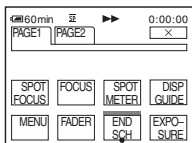

Touch here again to cancel the operation.

The last scene of the most recent recording is played back for about 5 seconds, and the camcorder enters the standby mode at the point where the last recording has finished.

- [END SCH] will not work correctly when there is a blank section between recorded sections on the tape.
- This operation is also available when the POWER switch is set to PLAY/EDIT.

## Searching manually (EDIT SEARCH)

You can search for the start point to start the next recording while viewing the pictures on the screen. The sound is not played back during the search.

**1** Touch **[FN]** → **[PAGE1]** → **[MENU]**.

**2** Select **[CAMERA SET]** with **[↓]** / **[↑]**, then touch **[EXEC]**.

**3** Select **[EDITSEARCH]** with **[↓]** / **[↑]**, then touch **[EXEC]**.

**4** Select **[ON]** with **[↓]** / **[↑]**, then touch **[EXEC]** → **[X]**.

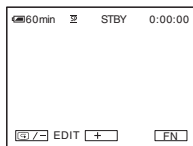

**5** Touch and hold **[G] / -** (to go backward) / **[+]** (to go forward) and release it at the point where you want the recording to start.

## Reviewing the most recently recorded scenes (Rec review)

You can view a few seconds of the scene recorded just before you stopped the tape.

- 1 Touch **FN** → **[PAGE1]** → **[MENU]**.
- 2 Select **📷** (CAMERA SET) with **↓** / **↑**, then touch **[EXEC]**.
- 3 Select **[EDITSEARCH]** with **↓** / **↑**, then touch **[EXEC]**.
- 4 Select **[ON]** with **↓** / **↑**, then touch **[EXEC]** → **✕**.

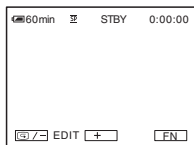

- 5 Touch **📷** / **-**.

The last few seconds of the most recently recorded scene are played back. Then, your camcorder is set to the standby.

# Playing the picture on a TV

You can connect your camcorder to the input jack of a TV or a VCR using the A/V connecting cable (1) or the A/V connecting cable with S VIDEO (2). Connect your camcorder to the wall outlet using the supplied AC Adaptor for this operation (p. 12). Refer also to the instruction manuals supplied with the devices to be connected.

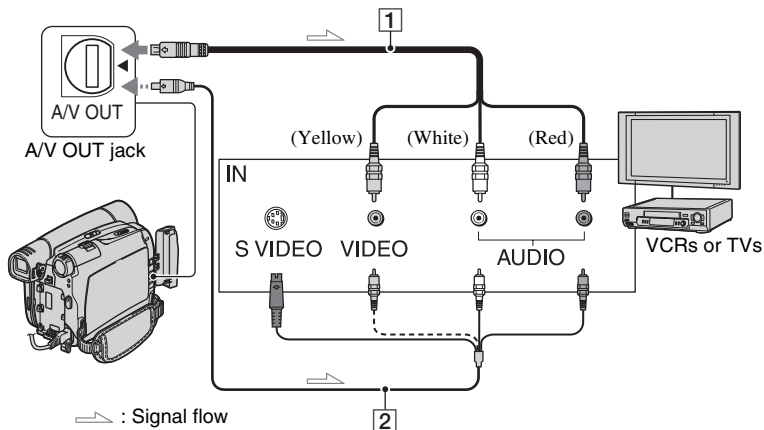

## 1 A/V connecting cable (supplied)

## 2 A/V connecting cable with S VIDEO (optional)

When connecting to another device via the S VIDEO jack, by using the A/V connecting cable with an S VIDEO cable, pictures can be reproduced more faithfully than with the supplied A/V cable connection.

Connect the white and red plugs (left/right audio) and S VIDEO plug (S VIDEO channel) of an A/V connecting cable. In this case, the yellow (standard video) plug connection is not necessary. S VIDEO connection only will not output audio.

- You can display the time code on the TV screen by setting [DISP OUT] to [V-OUT/LCD] (p. 47).

## When connecting your camcorder to a TV through a VCR

Connect your camcorder to the LINE IN input on the VCR. Set the input selector on the VCR to LINE (VIDEO 1, VIDEO 2, etc.), if the VCR has an input selector.

## When your TV is monaural (Only one audio input jack)

Connect the yellow plug of the A/V connecting cable to the video input jack and connect the white (left channel) or the red (right channel) plug to the audio input jack of your TV or VCR.





# Using the menu items

Follow the instructions below to use each of the menu items listed after this page.

## 1 Slide the POWER switch in the direction of the arrow repeatedly to turn on the respective lamp.

CAMERA lamp: settings for recording on a tape

PLAY/EDIT lamp: settings for viewing/editing

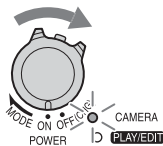

## 2 Touch the LCD screen to select the menu item.

Unavailable items will be grayed out.

### ■ To use the operation buttons on PAGE1/PAGE2/PAGE3

For details of the button items, see page 36.

- ① Touch .
- ② Touch the desired page.
- ③ Touch the desired button.
- ④ Select the desired setting, then touch  →  (close).
  - With some settings, you do not have to touch .

### ■ To use menu items

For details of the items, see page 42.

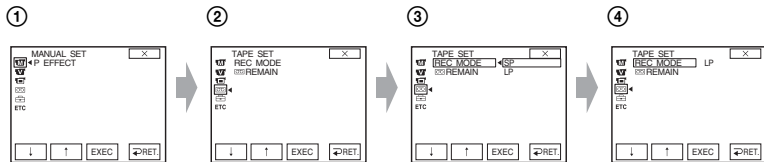

- ① Touch  → [MENU] on [PAGE1].  
The menu index screen appears.
- ② Select the desired menu.  
Touch  /  to select the item, then touch [EXEC]. (The process in step ③ and ④ is the same as that in step ②.)
- ③ Select the desired item.
- ④ Customize the item.  
After finishing the settings, touch  (close) to hide the menu screen.  
Each touch of [] takes you to the previous screen.

## ■ To use menu items during Easy Handycam operation

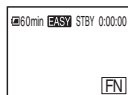

① Touch .

② Select the desired menu.

Touch [MENU] then select the desired menu.

③ Change your item setting.

After finishing the settings, touch  (close) to hide the menu screen.

Each touch of [ RET.] takes you to the previous screen.

- Cancel Easy Handycam operation to use menu items normally.

# Operation button items

Available operation buttons vary depending on the position of the lamp and the display (PAGE).

The default settings are marked with ▶.

The indicators in parentheses appear when the items are selected.

The available functions during Easy Handycam operation are marked with “\*\*”.  
**See page 34 for details on selecting button items.**

## When the CAMERA lamp lights up

### [PAGE1]

#### SPOT FOCUS

You can select and adjust the focal point to aim it at a subject not located in the center of the screen.

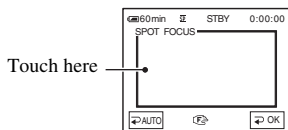

Touch the point where you want to focus on in the frame.

☞ appears.

To adjust the focus automatically, touch [↩ AUTO] or set [FOCUS] to [↩ AUTO].

- If you set [SPOT FOCUS], [FOCUS] is automatically set to [MANUAL].
- The setting returns to [↩ AUTO] when you turn the power off for more than 12 hours.

#### FOCUS

You can adjust the focus manually. You can select this function also when you want to focus on a certain subject intentionally.



- ① Touch [MANUAL].

☞ appears.

- ② Touch [⬅ +] (focusing on close subjects)/ [➡ +] (focusing on distant subjects) to sharpen the focus. 👤 appears when the focus cannot be adjusted any closer, and ▲ appears when the focus cannot be adjusted farther away.

To adjust the focus automatically, touch [↩ AUTO] in step ①.

- It is easier to focus on the subject by moving the power zoom lever towards T (telephoto) to adjust the focus, then towards W (wide angle) to adjust the zoom for recording. When you want to record a subject at close range, move the power zoom lever to W (wide angle), then adjust the focus.
- The minimum possible distance between camcorder and subject while maintaining sharp focus is about 1 cm (about 13/32 in.) for wide angle and about 80 cm (about 2 5/8 feet) for telephoto.
- The setting returns to [↩ AUTO] when you turn the power off for more than 12 hours.

#### SPOT METER (Flexible spot meter)

You can adjust and fix the exposure to the subject, so that it is recorded in suitable brightness even when there is strong contrast between the subject and the background, such as subjects in the spotlight on stage.

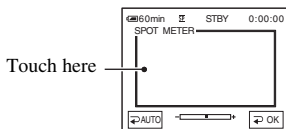

Touch the point where you want to fix and adjust the exposure on the screen.

☞ appears.

To return the setting to automatic exposure, touch [ AUTO ] or set [EXPOSURE] to [ AUTO ].

- If you set [SPOT METER], [EXPOSURE] is automatically set to [MANUAL].
- The setting returns to [ AUTO ] when you turn the power off for more than 12 hours.

## DISP GUIDE (Display Guide)\*

See page 17.

## MENU\*

See page 41.

## FADER

You can add the following effects to currently recording pictures.

- ① Select the desired effect in standby mode (to fade in) or recording mode (to fade out), then touch [ OK ] → [ X ].
- ② Press REC START/STOP.

The fader indicator stops flashing and disappears when the fade is complete.

To cancel [FADER] before starting the operation, touch [ OFF ] in step ①.

- If you press REC START/STOP once, the setting is canceled.



### WHITE



### BLACK



### MOSC. FADER



### MONOTONE

When fading in, the picture gradually changes from black and white to color. When fading out, it gradually changes from color to black and white.

### Using the viewfinder

You can adjust [EXPOSURE] and [FADER] while using the viewfinder by having the LCD panel rotated 180 degrees and closed with the screen facing out.

- 1 Make sure that the CAMERA lamp lights up.
- 2 Close the LCD panel with the screen facing out.  
[ OFF ] appears.
- 3 Touch [ OFF ].
- 4 Touch [ OK ].  
The LCD screen is turned off.
- 5 Touch the LCD screen while checking the display in the viewfinder.  
[EXPOSURE], etc. are displayed.
- 6 Touch the button you want to set.  
[EXPOSURE]: Adjust with [ ]/[ ], and touch [ OK ].  
[FADER]: Touch it repeatedly to select a desired effect.  
[ ON ]: The LCD screen lights up.

To hide the buttons, touch [ OK ].

## END SCH (END SEARCH)

See page 30.

### EXPOSURE

You can fix the brightness of a picture manually. Adjust the brightness when the subject is much brighter or darker than the background.

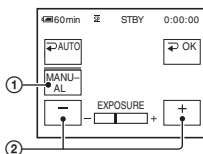

① Touch [MANUAL].

← → appears.

② Adjust the exposure by touching [ - ] / [ + ].

To return the setting to automatic exposure, touch [ ] AUTO].

- You can adjust [EXPOSURE] and [FADER] while using the viewfinder by having the LCD panel rotated 180 degrees and closed with the screen facing out (p. 37).
- The setting returns to [ ] AUTO] when you turn the power off for more than 12 hours.

### [PAGE2]

### WHT BAL (White balance)

You can adjust the color balance to the brightness of the recording environment.

#### ▶ AUTO

The white balance is adjusted automatically.

#### OUTDOOR ( )

The white balance is adjusted to be appropriate for the following recording conditions:

- Outdoors
- Night views, neon signs and fireworks
- Sunrise or sunset
- Under daylight fluorescent lamps

#### INDOOR ( )

The white balance is adjusted to be appropriate for the following recording conditions:

- Indoors
- At party scenes or studios where the lighting conditions change quickly
- Under video lamps in a studio, or under sodium lamps or incandescent-like color lamps

#### ONE PUSH ( )

The white balance will be adjusted according to the ambient light.

① Touch [ONE PUSH].

② Frame a white object such as a piece of paper, to fill the screen under the same lighting conditions as you will shoot the subject.

③ Touch [ ].

flashes quickly. When the white balance has been adjusted and stored in the memory, the indicator stops flashing.

• Do not shake your camcorder while is flashing quickly.

• flashes slowly if white balance could not be set.

• If keeps flashing even after you have touched [ ] OK], set [WHT BAL] to [ ] AUTO].

- If you have changed the battery pack while [ ] AUTO] was selected, or taken your camcorder outdoors after inside use with the [EXPOSURE] set (or vice versa), select [ ] AUTO] and aim your camcorder at a nearby white object for about 10 seconds for better color balance adjustment.
- Redo the [ONE PUSH] procedure if you change the [PROGRAM AE] settings, or bring your camcorder outdoors from inside the house, or vice versa.
- Set [WHT BAL] to [ ] AUTO] or [ONE PUSH] under white or cool white fluorescent lamps.
- The setting returns to [ ] AUTO] when you turn the power off for more than 12 hours.

## LCD BRT (LCD bright)

You can adjust the brightness of the LCD screen. The recorded picture will not be affected by this operation.

Adjust the brightness with  $\boxed{-}$ / $\boxed{+}$ .

## When the PLAY/EDIT lamp lights up

You can use the video operation buttons ( $\boxed{\blacksquare}$ / $\boxed{\llcorner}$ / $\boxed{\blacktriangleright}$ / $\boxed{\blacktriangleright}$ ) on every PAGE.

## [PAGE1]

### MENU\*

See page 41.

### VOL\* (Volume)

See page 25.

### END SCH (END SEARCH)

See page 30.

### DISP GUIDE (Display Guide)\*

See page 17.

## [PAGE2]

### DATA CODE\*

During playback, displays information (data code) recorded automatically at the time of recording.

#### ▶ $\blacktriangleleft$ OFF

Data code is not displayed.

#### DATE/TIME

Displays the date and time.

#### CAM DATA (below)

Displays camera setting data.

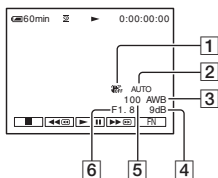

- 1 SteadyShot off
- 2 Exposure
- 3 White balance
- 4 Gain
- 5 Shutter speed
- 6 Aperture value

- In the [DATE/TIME] data display, the date and time are displayed in the same area. If you record a picture without setting the clock, [--- --:--] and [--:--:--] will appear.
- During Easy Handycam operation, you can set [DATE/TIME] only.

## LCD BRT (LCD bright)

You can adjust the brightness of the LCD screen. The recorded picture will not be affected by this operation.

Adjust the brightness with  $\boxed{-}$ / $\boxed{+}$ .

## [PAGE3]

### V SPD PLAY (Various speed playback)

You can play back in various modes while viewing movies.

- ① Touch the following buttons during playback.

To	Touch
change the playback direction*	(frame)
play back slowly**	SLOW] To reverse direction: (frame) → SLOW]
play back 2 times faster (double speed)	(double speed) To reverse direction: (frame) →  (double speed)
play back frame by frame	(frame) during playback pause. To reverse direction: (frame) during frame playback.

\* Horizontal lines may appear at the top, bottom, or in the center of the screen. This is not a malfunction.

\*\*Pictures output from the DV Interface (i.LINK) cannot be played back smoothly in slow mode.

- ② Touch [ RET.] → .

To return to the normal playback mode, touch (Play/Pause) twice (once from frame playback).

- You will not hear the recorded sound. You may see mosaic-like images of the previously played picture.

## A DUB CTRL (Audio dubbing)

See page 52.

## REC CTRL (Recording control)

See page 50.



# Menu items

- Available menu items (●) vary depending on which lamp is lit.
- During Easy Handycam operation, the following settings are automatically applied (p. 22).

	CAMERA	PLAY/EDIT	Easy Handycam
<b>MANUAL SET menu</b> (p. 42)			
PROGRAM AE	●	–	AUTO
P EFFECT	●	●	OFF
AUTO SHTR	●	–	ON
<b>CAMERA SET menu</b> (p. 43)			
D ZOOM	●	–	OFF
WIDE SEL	●	–	4:3
STEADYSHOT	●	–	ON
EDITSEARCH	●	–	OFF
N.S.LIGHT	●	–	ON
<b>VCR SET menu</b> (p. 45)			
AUDIO MIX	–	●	–
<b>LCD/VF SET menu</b> (p. 45)			
LCD B.L.	●	●	BRT NORMAL
LCD COLOR	●	●	–
VF B.L.	●	●	BRT NORMAL
WIDE DISP	●	●	–
<b>TAPE SET menu</b> (p. 46)			
REC MODE	●	●	SP
AUDIO MODE	●	–	12BIT
REMAIN	●	●	AUTO
<b>SETUP MENU menu</b> (p. 47)			
CLOCK SET	●	●	●
LANGUAGE	●	●	●
DEMO MODE	●	–	ON
<b>OTHERS menu</b> (p. 47)			
WORLD TIME	●	●	–*
BEEP	●	●	●
A.SHUT OFF	●	●	5min
DISP OUT	●	●	LCD

\* The value set before Easy Handycam operation will be retained during Easy Handycam operation.

# MANUAL SET menu

– PROGRAM AE/P EFFECT, etc.

The default settings are marked with ►. The indicators in parentheses appear when the items are selected.

See page 34 for details on selecting menu items.

## PROGRAM AE

You can record pictures effectively in various situations with the PROGRAM AE function.

### ► AUTO

Select to automatically record pictures effectively without the [PROGRAM AE] function.

### SPOTLIGHT\* (☹)

Select to prevent people's faces from appearing excessively white when subjects are lit by strong light.



### PORTRAIT (Soft portrait) (👤)

Select to bring out the subject such as people or flowers while creating a soft background.



### SPORTS\* (Sports lesson) (🏃)

Select to minimize shake when shooting fast moving subjects.



### BEACH&SKI\* (🏖️)

Select to prevent people's faces from appearing dark in strong light or reflected light, such as at a beach in midsummer or on a ski slope.



### SUNSETMOON\*\* (🌅)

Select to maintain the atmosphere of situations such as sunsets, general night views or fireworks.



### LANDSCAPE\*\* (🏞️)

Select to shoot distant subjects clearly. This setting also prevents your camcorder from focusing on glass or metal mesh in windows that comes in between the camcorder and the subject.



- Items with one asterisk (\*) can be adjusted to focus on subjects only a short distance away. Items with two asterisks (\*\*) can be adjusted to focus on subjects farther away.
- The setting returns to [AUTO] when you turn the power off for more than 12 hours.

## P EFFECT (Picture effect)

You can add special effects to a picture during recording or playback.  appears.

### ► OFF

Does not use [P EFFECT] setting.

### NEG.ART

The color and brightness are reversed.



# CAMERA SET menu

– D ZOOM/WIDE SEL/STEADYSHOT, etc.

## SEPIA

Pictures appear in sepia.

## B&W

Pictures appear in black and white.

## SOLARIZE

Pictures appear as an illustration with strong contrast.



## PASTEL\*

Pictures appear as a pale pastel drawing.



## MOSAIC\*

Pictures appear mosaic-patterned.



\* Not available during playback.

- You can record pictures edited with special effects on another VCR/DVD device, etc. (p. 48).
- You cannot output playback pictures edited with picture effects via the  DV Interface (i.LINK).
- You cannot add effects to externally input pictures.

## AUTO SHTR (Auto shutter)

Automatically activates the electronic shutter to adjust the shutter speed when recording in bright conditions if you set it to [ON] (the default setting).

The default settings are marked with ►. The indicators in parentheses appear when the items are selected.

**See page 34 for details on selecting menu items.**

## D ZOOM (Digital zoom)

You can select the maximum zoom level in case you want to zoom to a level greater than 20 × (the default setting) while recording on a tape. Note that the image quality decreases when you are using the digital zoom.

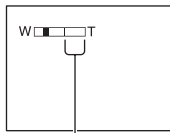

The right side of the bar shows the digital zooming factor. The zooming zone appears when you select the zooming level.

## ► OFF

Up to 20 × zoom is performed optically.

## 40 ×

Up to 20 × zoom is performed optically, and after that, up to 40 × zoom is performed digitally.

## 800 ×

Up to 20 × zoom is performed optically, and after that, up to 800 × zoom is performed digitally.

**WIDE SEL (Wide select)**

You can record a picture in a ratio suitable for the screen on which it will be displayed. Refer also to the operating instructions supplied with your TV for details.

**▶ 4:3**

Standard setting (to record pictures to be played back on a 4:3 TV).

**16:9 WIDE (16:9)**

Records pictures to be played back on a 16:9 wide TV in full screen mode.

- When you record a picture to be played back on a 16:9 wide TV connected to your camcorder, select [16:9 WIDE]. The recorded picture will be played in full mode when you connect to your ID-1/ID-2 compatible TV.

When viewed on the LCD screen/viewfinder with [16:9 WIDE] selected.

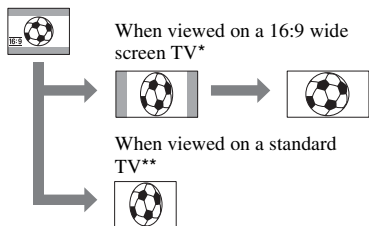

\* Picture appears in full screen mode when the wide-screen TV switches to full mode.

\*\* Played in 4:3 mode. When you play a picture in the wide mode, it appears as you have seen on the LCD screen or in the viewfinder.

**STEADYSHOT**

You can compensate for camera shake (the default setting is [ON]). Set [STEADYSHOT] to [OFF] (OFF) when using a tripod (optional) or the conversion lens (optional), then the image becomes natural.

**EDITSEARCH****▶ OFF**

Does not display [G/-] or [+ ] on the LCD screen.

**ON**

Displays [G/-] and [+ ] on the LCD screen, and enables the EDIT SEARCH function and Rec review (p. 30).

**N.S.LIGHT (NightShot Light)**

When using the NightShot plus (p. 26) function to record, you can record clearer pictures by setting [N.S.LIGHT], which emits infrared light (invisible), to [ON] (the default setting).

- Do not cover the infrared port with your fingers or other objects (p. 26).
- Remove the conversion lens (optional) if it is attached.
- The maximum shooting distance using [N.S.LIGHT] is about 3 m (10 feet). If you record subjects in dark places, such as night scenes or in moonlight, set [N.S.LIGHT] to [OFF]. You can make the image color deeper this way.

## VCR SET menu

– AUDIO MIX

See page 34 for details on selecting menu items.

### AUDIO MIX

See page 52.

## LCD/VF SET menu

– LCD B.L./LCD COLOR/VF B.L., etc

The default settings are marked with ►.  
See page 34 for details on selecting menu items.

### LCD B.L. (LCD back light)

You can adjust the brightness of the LCD screen's backlight. The recorded picture will not be affected by this operation.

#### ► BRT NORMAL



Standard brightness.

#### **BRIGHT**

Brightens the LCD screen.

- When you connect your camcorder to outside power sources, [BRIGHT] is automatically selected for the setting.
- When you select [BRIGHT], battery life is slightly reduced during recording.

### LCD COLOR

You can adjust the color on the LCD screen with  / . The recorded picture will not be affected by this operation.

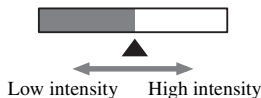

## – REC MODE/AUDIO MODE/REMAIN

**VF B.L. (Viewfinder back light)**

You can adjust the brightness of the viewfinder. The recorded picture will not be affected by this operation.

**▶ BRT NORMAL**

Standard brightness.

**BRIGHT**

Brightens the viewfinder screen.

- When you connect your camcorder to outside power sources, [BRIGHT] is automatically selected for the setting.
- When you select [BRIGHT], battery life is slightly reduced during recording.

**WIDE DISP (Wide display)**

You can select how a 16:9 aspect ratio picture appears in the viewfinder and the LCD screen by setting [WIDE SEL] to [16:9 WIDE]. The recorded picture will not be affected by this operation.

**▶ LETTER BOX**

Normal setting (standard type of display)

**SQUEEZE**

Expands the picture vertically if black bands at the top and bottom in 16:9 aspect ratio are undesirable.

The default settings are marked with ▶. The indicators in parentheses appear when the items are selected.

**See page 34 for details on selecting menu items.**

**REC MODE (Recording mode)****▶ SP (SP)**

Records in the SP (Standard Play) mode on a cassette.

**LP (LP)**

Increases the recording time to 1.5 times the SP mode (Long Play).

- If you record in the LP mode, a mosaic-like noise may appear or sound may be interrupted when you play back the tape on other camcorders or VCRs.
- When you mix recordings in the SP mode and in the LP mode on one tape, the playback picture may be distorted or the time code may not be written properly between the scenes.

**AUDIO MODE****▶ 12BIT**

Records in the 12-bit mode (2 stereo sounds).

**16BIT (16b)**

Records in the 16-bit mode (1 stereo sound with high quality).

 **REMAIN****▶ AUTO**

Displays the remaining tape indicator for about 8 seconds in situations such as those described below.

- When you set the POWER switch to PLAY/EDIT or CAMERA with a cassette inserted.
- When you touch  (Play/Pause).

**ON**

Always displays the remaining tape indicator.



## SETUP MENU

### menu

– CLOCK SET/LANGUAGE, etc.

See page 34 for details on selecting menu items.

#### CLOCK SET

See page 19.

#### LANGUAGE

You can select the language to be used on the LCD screen.

- Your camcorder offers [ENG[SIMP]] (simplified English) for when you cannot find your native tongue among the options.

#### DEMO MODE

The default setting is [ON], allowing you to view the demonstration in about 10 minutes, after you have removed a cassette from your camcorder, and slide the POWER switch repeatedly to turn on the CAMERA lamp.

- The demonstration will be suspended in situations such as those described below.
  - When you touch the screen during the demonstration. (The demonstration starts again after about 10 minutes.)
  - When a cassette is inserted.
  - When the POWER switch is set to other than CAMERA.



## OTHERS menu

– WORLD TIME/BEEP, etc.

The default settings are marked with ►. See page 34 for details on selecting menu items.

#### WORLD TIME

When using your camcorder abroad, you can set the time difference by touching / , the clock will be adjusted in accordance with the time difference.

If you set the time difference to 0, the clock returns to the originally set time.

#### BEEP

##### ► ON

A melody sounds when you start/stop recording, or operate the touch panel.

##### OFF

Cancels the melody.

#### A.SHUT OFF (Auto shut off)

##### ► 5min

The camcorder is automatically turned off when you do not operate your camcorder for more than approximately 5 minutes.

##### NEVER

The camcorder is not automatically turned off.

- When you connect your camcorder to a wall outlet, [A.SHUT OFF] is automatically set to [NEVER].

#### DISP OUT (Display output)

##### ► LCD

Shows displays such as the time code on the LCD screen and in the viewfinder.

##### V-OUT/LCD

Shows displays such as the time code on the TV screen, LCD screen, and in the viewfinder.

## Dubbing to VCR/DVD device, etc.

You can copy the picture played back on your camcorder to other recording devices (VCR/ DVD device, etc.).

You can connect your camcorder to a VCR/DVD device, etc., using the A/V connecting cable (1), the A/V connecting cable with S VIDEO (2), or the i.LINK cable (3).

Connect your camcorder to the wall outlet using the supplied AC Adaptor for this operation (p. 12). Refer also to the instruction manuals supplied with the devices to be connected.

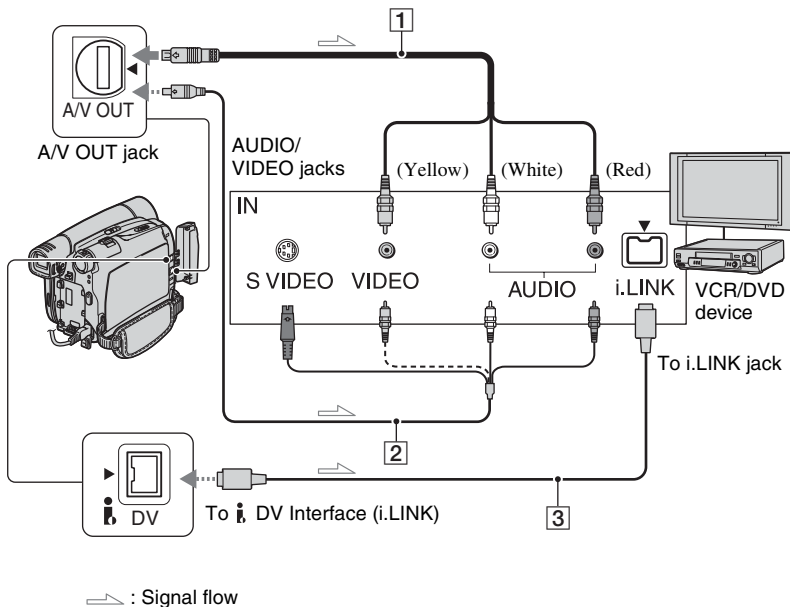

### 1 A/V connecting cable (supplied)

### 2 A/V connecting cable with S VIDEO (optional)

When connecting to another device via the S VIDEO jack, by using the A/V connecting cable with an S VIDEO cable, pictures can be reproduced more faithfully than with the supplied A/V cable connection. Connect the white and red plugs (left/right audio) and S VIDEO plug (S VIDEO channel) of an A/V connecting cable. In this case, the yellow (standard video) plug connection is not necessary. S VIDEO connection only will not output audio.

### 3 i.LINK cable (optional)

Use an i.LINK cable to connect your camcorder to another device equipped with an i.LINK jack. The video and audio signals are transmitted digitally, producing high quality pictures and sound. Note that you cannot output picture and sound separately.

- When you are connecting your camcorder to a monaural device, connect the yellow plug of the A/V connecting cable to the video jack, and the red (right channel) or the white (left channel) plug to the audio jack on the VCR/TV.
- When you connect a device via an A/V connecting cable, set [DISP OUT] to [LCD] (the default setting) (p. 47).



---

## 1 Prepare your camcorder for playback.

Insert the recorded cassette.

Slide the POWER switch repeatedly to turn on the PLAY/EDIT lamp.

---

## 2 Prepare your VCR/DVD device for recording.

When dubbing to the VCR, insert a cassette for recording.

When dubbing to the DVD recorder, insert a DVD for recording.

If your recording device has an input selector, set it to the appropriate input (such as video input1, video input2).

---

## 3 Connect your VCR/DVD device to your camcorder as a recording device.

Connect your camcorder to the input jacks of a VCR or a DVD device.

---

## 4 Start playback on the camcorder, and recording on the VCR/DVD device.

Refer to the operating instructions supplied with your recording device for details.

---

## 5 When dubbing is complete, stop your camcorder and the VCR/DVD device.

---

- To record the date/time and camera settings data when connected by the A/V connecting cable, display them on the screen (p. 39, 47).
- The following cannot be output via the DV Interface (i.LINK):
  - Indicators
  - Pictures edited using [P EFFECT] (p. 42)
- When connected using an i.LINK cable, the recorded picture becomes rough when a picture is paused on your camcorder while recording to a VCR.
- When connected using an i.LINK cable, data code (date/time/camera settings data) may not be displayed or recorded depending on the device or application.

# Recording pictures from a TV or VCR/DVD device, etc.

Using an i.LINK cable (optional), you can record pictures or TV programs from a TV or VCR/DVD device, etc., on a tape.

Be sure to insert a cassette for recording in your camcorder beforehand.

You can connect your camcorder to a TV, VCR/DVD or an i.LINK-compatible device using the i.LINK cable (optional).

Connect your camcorder to the wall outlet using the supplied AC Adaptor for this operation (p. 12). Refer also to the instruction manuals supplied with the devices to be connected.

- **You cannot record pictures on your camcorder from a TV or VCR/DVD device that does not have an i.LINK jack.**
- You cannot input picture and sound separately.

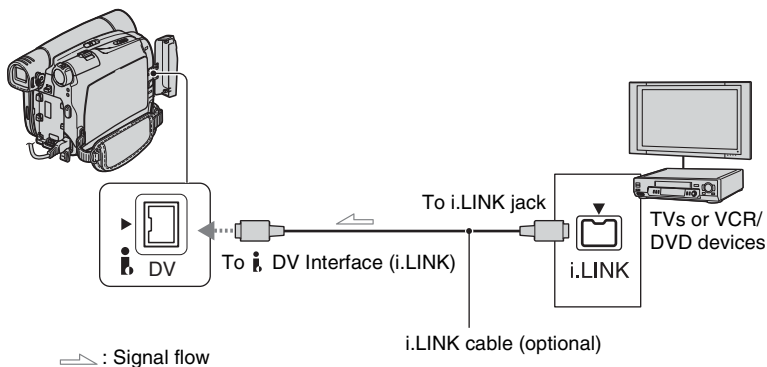

## 1 Connect your TV or VCR/DVD device to your camcorder with an i.LINK cable.

- The DV<sub>IN</sub> indicator appears when you connect your camcorder and other devices via an i.LINK cable. (This indicator may also appear on the connected device.)

## 2 If you are recording from a VCR/DVD device, insert a cassette or a DVD.

## 3 Slide the POWER switch repeatedly to turn on the PLAY/EDIT lamp.

## 4 Set your camcorder to recording pause mode.

Touch → [PAGE3] → [REC CTRL] → [REC PAUSE].

## 5 When recording pictures from a VCR/DVD device:

**Start playing the cassette or the disc on the VCR/DVD device.**

**When recording pictures from a TV:**

**Select a TV program.**

The picture played on the connected device appears on the LCD screen of your camcorder.

---

**6** Touch [REC START] at the point you want to start recording.

---

**7** Stop recording.

Touch  (Stop) or [REC PAUSE].

---

**8** Touch [ RET.] → .

---

## Dubbing sound to a recorded tape

You can add sound to a tape already recorded in the 12-bit mode (p. 46) without erasing the original sound.

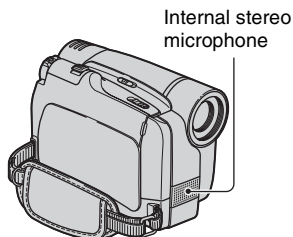

You can record audio by using the internal stereo microphone.

- You cannot record additional audio:
  - When the tape has been recorded in the 16-bit mode (p. 46).
  - When the tape has been recorded in the LP mode.
  - When your camcorder is connected via an i.LINK cable.
  - When the tape has been recorded in 4CH MIC mode.
  - On blank sections of the tape.
  - When the tape has been recorded in a TV color system other than that of your camcorder (p. 64).
  - When the write-protect tab of the cassette is set to SAVE (p. 65).
  - On sections recorded in HDV format.
- When you add sound, the picture will not be output from the A/V OUT jack. Check the picture on the LCD screen or the viewfinder.

## Dubbing sound to a recorded tape (Continued)

### Recording sound

Insert a recorded cassette into your camcorder beforehand.

**1** Slide the **POWER** switch repeatedly to turn on the **PLAY/EDIT** lamp.

**2** Touch **▶||** (**Play/Pause**) to play back the tape, then touch it again at the point where you want to start recording the sound.

**3** Touch **FN** → **[PAGE3]** → **[A DUB CTRL]** → **[AUDIO DUB]**.

⏸ appears.

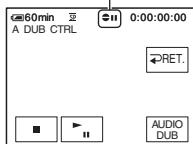

**4** Touch **▶||** (**Play**) and start playing back the audio you want to record at the same time.

⦿ appears while recording the new sound in stereo 2 (ST2) during the playback of the tape.

**5** Touch **■** (**Stop**) when you want to stop recording.

To dub on other scenes, repeat step **2** to select scenes, then touch **[AUDIO DUB]**.

**6** Touch **[↶ RET.]** → **[X]**.

- You can only record additional audio over a tape recorded on your camcorder. The sound may deteriorate when you dub audio on a tape recorded on other camcorders (including other DCR-HC28 camcorders).

### To check the recorded sound

- ① Play back the tape on which you have recorded audio (p. 25).
- ② Touch **FN** → **[PAGE1]** → **[MENU]**.
- ③ Select **V** (**VCR SET**), then touch **↓** / **↑** to select **[AUDIO MIX]**, then touch **[EXEC]**.

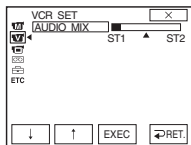

- ④ Touch **↓** / **↑** to adjust the balance of the original sound (ST1) and the new sound (ST2), then touch **[EXEC]**.

- The original sound (ST1) is output at the default setting.
- Audio balance adjustment returns to the default setting after 12 hours of turning the power off.

# Jacks to connect external devices

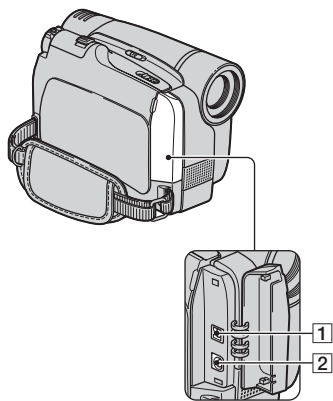

Open the jack cover.

- 1 DV Interface (i.LINK) (p. 48, 50)
- 2 A/V (audio/video) OUT jack (p. 32, 48)
- 3 DC IN jack (p. 12)

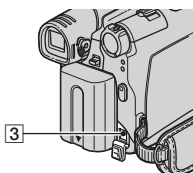

# Troubleshooting

If you run into any problems using your camcorder, use the following table to troubleshoot the problem. If the problem persists, disconnect the power source and contact your Sony dealer.

## Overall operations/Easy Handycam

### The power does not turn on.

- Attach a charged battery pack to the camcorder (p. 12).
- Use the AC Adaptor to connect to a wall outlet (p. 12).

---

### The camcorder does not operate even when the power is set to on.

- Disconnect the AC Adaptor from the wall outlet or remove the battery pack, then reconnect it after about 1 minute.
- Press the RESET button (p. 27) using a sharp-pointed object. (If you press the RESET button, all settings are reset.)

---

### Buttons do not work.

- During Easy Handycam operation, not all buttons are functional (p. 23).

---

### Settings change during Easy Handycam operation.

- During Easy Handycam operation, the settings of the functions that are not displayed on the screen return to their defaults. Previously made settings are restored when you cancel the Easy Handycam operation (p. 22, 41).

---

### [DEMO MODE] does not start.

- You cannot view the demonstration together with NightShot plus (p. 26).
- Eject the cassette from your camcorder (p. 20).

---

### The camcorder gets warm.

- The camcorder may get warmer while you use it. This is not a malfunction.

## Batteries/Power sources

### The power abruptly turns off.

- When approximately 5 minutes have elapsed while you do not operate your camcorder, the camcorder is automatically turned off (A.SHUT OFF). Change the setting of [A.SHUT OFF] (p. 47), or turn on the power again (p. 15), or use the AC Adaptor.
- Charge the battery pack (p. 12).

---

### The CHG (charge) lamp does not light while the battery pack is being charged.

- Slide the POWER switch to OFF(CHG) (p. 12).
- Attach the battery pack to the camcorder correctly (p. 12).
- Connect the power cord to the wall outlet properly (p. 12).
- The battery charge is completed (p. 13).

---

**The CHG (charge) lamp flashes while the battery pack is being charged.**

- Attach the battery pack to the camcorder correctly (p. 12). If the problem persists, disconnect the AC Adaptor from the wall outlet and contact your Sony dealer. The battery pack may be worn-out.

---

**The power turns off frequently although the remaining battery time indicator indicates that the battery pack has enough power to operate.**

- A problem has occurred in the remaining battery time indicator, or the battery pack has not been charged enough. Fully charge the battery again to correct the indication (p. 12).

---

**The remaining battery time indicator does not indicate the correct time.**

- Ambient temperature is too high or too low, or the battery pack has not been charged enough. This is not a malfunction.
- Fully charge the battery again. If the problem persists, the battery may be worn-out. Replace it with a new one (p. 12, 66).
- The indicated time may not be correct in certain circumstances. For example, when you open or close the LCD panel, it takes about 1 minute to display the correct remaining battery time.

---

**The battery pack discharges too quickly.**

- Ambient temperature is too high or too low, or the battery pack has not been charged enough. This is not a malfunction.
- Fully charge the battery again. If the problem persists, the battery may be worn-out. Replace it with a new one (p. 12, 66).

---

**A problem occurs when the camcorder is connected to the AC Adaptor.**

- Turn off the power, and disconnect the AC Adaptor from the wall outlet. Then, connect it again.

---

**LCD screen/viewfinder**

---

**A rippling effect appears on the LCD screen when you touch it.**

- This is not a malfunction. Do not press hard on the LCD screen.

---

**An unknown picture appears on the LCD screen or viewfinder.**

- The camcorder is in [DEMO MODE] (p. 47). Touch the LCD screen or insert a cassette to cancel [DEMO MODE].

---

**An unknown indicator appears on the screen.**

- A warning indicator or message appears on the screen (p. 61).

## Troubleshooting (Continued)

---

### **The picture remains on the LCD screen.**

- This occurs if you disconnect the DC plug from your camcorder or remove the battery pack without turning off the power first. This is not a malfunction.
- 

### **The buttons do not appear on the touch panel.**

- Touch the LCD screen lightly.
  - Press DISP/BATT INFO on your camcorder (p. 17).
- 

### **The buttons on the touch panel do not work correctly or do not work at all.**

- Adjust the screen ([CALIBRATION]) (p. 70).
- 

### **The picture in the viewfinder is not clear.**

- Move the viewfinder lens adjustment lever until the picture appears clearly (p. 16).
- 

### **The picture in the viewfinder has disappeared.**

- Close the LCD panel. The picture is not displayed in the viewfinder when the LCD panel is open (p. 16).
- 

### **Dots in lines appear on the LCD screen.**

- This is not a malfunction. These dots are not recorded.
- 

## Cassette tapes

### **The cassette cannot be ejected from the compartment.**

- Make sure the power source (battery pack or AC Adaptor) is connected correctly (p. 12).
  - Remove the battery pack from the camcorder, then attach it again (p. 13).
  - Attach a charged battery pack to the camcorder (p. 12).
  - Moisture condensation has occurred inside the camcorder (p. 69).
- 

### **The Cassette Memory indicator or title display does not appear while using a cassette with Cassette Memory.**

- This camcorder does not support Cassette Memory, so the indicator does not appear.
- 

### **The remaining tape indicator is not displayed.**

- Set [REMAIN] to [ON] to always display the remaining tape indicator (p. 46).
- 

### **The cassette is noisier during rewinding or fast-forwarding.**

- When using the AC Adaptor, rewind/fast forward speed increases (compared with battery operation) and therefore increases noise. This is not a malfunction.



## Recording

Refer also to “Adjusting the image during recording” (p. 57).

---

### The tape does not start when you press REC START/STOP.

- Slide the POWER switch repeatedly to turn on the CAMERA lamp (p. 24).
- The tape has reached the end. Rewind it, or insert a new cassette.
- Set the write-protect tab to REC or insert a new cassette (p. 65).
- The tape is stuck to the drum due to moisture condensation. Remove the cassette and leave your camcorder for at least 1 hour, then re-insert the cassette (p. 69).

---

### You cannot record a smooth transition on a tape from the last recorded scene to the next.

- Perform END SEARCH (p. 30).
- Do not remove the cassette. (The picture will be recorded continuously without a break even when you turn the power off.)
- Do not record pictures in SP mode and LP mode on the same tape.
- Avoid stopping then recording a movie in the LP mode.

---

### [END SCH] does not work.

- Do not eject the cassette after recording (p. 30).
- There is nothing recorded on the cassette.

---

### [END SCH] does not work correctly.

- There is a blank section between recorded sections of the tape. This is not a malfunction.

## Adjusting the image during recording

Refer also to “Menu” (p. 59).

---

### The auto focus does not function.

- Set [FOCUS] to [↔ AUTO] (p. 36).
- The recording conditions are not suitable for auto focus. Adjust the focus manually (p. 36).

---

### [STEADYSHOT] does not function.

- Set [STEADYSHOT] to [ON] (p. 44).

---

### The BACK LIGHT function does not function.

- In the following settings, the BACK LIGHT function is canceled.
  - [MANUAL] of [EXPOSURE]
  - [SPOT METER]
- The BACK LIGHT function does not work during Easy Handycam operation (p. 23).

### **A vertical band appears when recording candlelight or electric light in the dark.**

- This occurs when the contrast between the subject and the background is too high. This is not a malfunction.
- 

### **A vertical band appears when recording a bright subject.**

- This phenomenon is called the smear effect. This is not a malfunction.
- 

### **The color of the picture is not correctly displayed.**

- Deactivate the NightShot plus function (p. 26).
- 

### **The screen picture is bright, and the subject does not appear on the screen.**

- Deactivate the NightShot plus function (p. 26), or cancel the BACK LIGHT function (p. 26).
- 

### **The picture appears too bright, or flickering or changes in color occurs.**

- These anomalies may occur when recording pictures under the discharge tube, such as a fluorescent lamp, sodium lamp, or mercury lamp, with [PORTRAIT] or [SPORTS]. This is not a malfunction. Cancel [PROGRAM AE] to reduce the anomaly (p. 42).
- 

### **Black bands appear when you record a TV screen or computer screen.**

- Set [STEADYSHOT] to [OFF] (p. 44).
- 

## Playback

### **You cannot play back tape.**

- Slide the POWER switch repeatedly to turn on the PLAY/EDIT lamp.
  - Rewind the tape (p. 25).
- 

### **Horizontal lines appear on the picture. The displayed pictures are not clear or do not appear.**

- Clean the head using the cleaning cassette (optional) (p. 69).
- 

### **No sound or only a low sound is heard.**

- Turn up the volume (p. 25).
- Adjust [AUDIO MIX] from the [ST2] (additional sound) side until the sound is heard appropriately (p. 52).
- If you are using an S VIDEO plug, make sure the red and white plugs of the A/V connecting cable are also connected (p. 32).

---

**The sound breaks off.**

- Clean the head using the cleaning cassette (optional) (p. 69).

---

**“---” is displayed on the screen.**

- The tape you are playing was recorded without setting the date and time.
- A blank section on the tape is being played.
- The data code on a tape with a scratch or noise cannot be read.

---

**Noises appear and **PA** is displayed on the screen.**

- The tape was recorded in a TV color system other than that of your camcorder (NTSC). This is not a malfunction (p. 64).

---

**4ch-12b is displayed on the screen.**

- The tape you are playing was recorded on another device with a 4ch microphone (4CH MIC REC). Your camcorder is not compatible with 4ch microphone recording.

## Menu

---

**Menu items are grayed out.**

- You cannot select grayed items in the current recording/playback situation.

---

**You cannot use [SPOT FOCUS].**

- You cannot use [SPOT FOCUS] together with [PROGRAM AE].

---

**You cannot use [SPOT METER].**

- You cannot use [SPOT METER] together with NightShot plus.
- If you set [PROGRAM AE], [SPOT METER] is automatically set to [↔ AUTO].

---

**You cannot use [EXPOSURE].**

- You cannot use [EXPOSURE] together with NightShot plus.
- If you set [PROGRAM AE], [EXPOSURE] is automatically set to [↔ AUTO].

---

**You cannot use [WHT BAL].**

- You cannot use [WHT BAL] together with NightShot plus.

---

**You cannot use [PROGRAM AE].**

- You cannot use [PROGRAM AE] together with NightShot plus.

### Dubbing/Editing/Connecting to other devices

**Time code and other information appear on the display of the connected device.**

- Set [DISP OUT] to [LCD] while connected with an A/V connecting cable (p. 47).

---

**You cannot dub correctly using the A/V connecting cable.**

- The A/V connecting cable is not connected properly. Make sure that the A/V connecting cable is connected to the input jack of another device for dubbing a picture from your camcorder (p. 48).

---

**New sound added to a recorded tape is not heard.**

- Adjust [AUDIO MIX] from the [ST1] (original sound) side until the sound is heard appropriately (p. 52).

---

**Pictures from connected devices are not displayed correctly.**

- The input signal is not NTSC (p. 64).

### Connecting to a computer

**The computer does not recognize your camcorder.**

- Disconnect the cable from the computer and camcorder, then connect it again securely.
- Disconnect the cable from the computer and camcorder, restart the computer, then connect them again correctly.

---

**You cannot view the video your camcorder is seeing on the computer.**

- Disconnect the cable from the computer, turn on the camcorder, then connect it again.

---

**You cannot view the video recorded on a tape on the computer.**

- Disconnect the cable from the computer, then connect it again.

# Warning indicators and messages

## Self-diagnosis display/Warning indicators

If indicators appear on the LCD screen or in the viewfinder, check the following. Some symptoms you can fix by yourself. If the problem persists even after you have tried a couple of times, contact your Sony dealer or local authorized Sony service facility.

### C:(or E:) □□:□□ (Self-diagnosis display)

#### C:04:□□

- The battery pack is not an “InfoLITHIUM” battery pack. Use an “InfoLITHIUM” battery pack (p. 66).
- Connect the DC plug of the AC Adaptor to the DC IN jack of your camcorder securely (p. 12).

#### C:21:□□

- Moisture condensation has occurred. Remove the cassette and leave your camcorder for at least 1 hour, then re-insert the cassette (p. 69).

#### C:22:□□

- Clean the head using a cleaning cassette (optional) (p. 69).

#### C:31:□□ / C:32:□□

- Symptoms that are not described above have occurred. Remove and insert the cassette, then operate your camcorder again. Do not perform this procedure if moisture condensation has occurred (p. 69).
- Remove the power source. Reconnect it and operate your camcorder again.
- Change the cassette. Press RESET (p. 27), and operate your camcorder again.

#### E:61:□□ / E:62:□□

- Contact your Sony dealer or local authorized Sony service facility. Inform them of the 5-digit code, which starts from “E.”

### (Battery level warning)

- The battery pack is nearly used up.
- Depending on the operating environment, or battery conditions,  may flash, even if there are approximately 5 to 10 minutes remaining.

### (Moisture condensation warning)\*

- Eject the cassette, remove the power source, and then leave it for about 1 hour with the cassette lid open (p. 69).

### (Warning indicators pertaining to the tape)

#### Slow flashing:

- There is less than 5 minutes remaining on the tape.
- No cassette is inserted.\*
- The write-protect tab on the cassette is set to lock (p. 65).\*

#### Fast flashing:

- The tape has run out.\*

### (Eject cassette warning)\*

#### Slow flashing:

- The write-protect tab on the cassette is set to lock (p. 65).

#### Fast flashing:

- Moisture condensation has occurred (p. 69).
- The self-diagnosis display code is displayed (p. 61).

\* You hear a melody when the warning indicators appear on the screen (p. 47).

## Warning indicators and messages (Continued)

### Description of warning messages

If messages appear on the screen, follow the instructions.

#### ■ Battery/Power

**Use the “InfoLITHIUM” battery pack.** (p. 66)

**Battery level is low.**

- Change the battery (p. 12, 66).

**Old battery. Use a new one.** (p. 66)

**▲ Re-attach the power source.** (p. 12)

**Use new AC adapter or reinsert.** (p. 12)

#### ■ Moisture condensation

**☒▲ Moisture condensation. Eject the cassette** (p. 69)

**☒ Moisture condensation. Turn off for 1H.** (p. 69)

#### ■ Cassette/Tape

**☒ Insert a cassette.** (p. 20)

**▲ Reinsert the cassette.** (p. 20)

- Check if the cassette is damaged.

**☒▲ The tape is locked - check the tab.** (p. 65)

**☒ The tape has reached the end.** (p. 20, 25)

- Rewind or change the tape.

#### ■ Others

**Cannot record due to copyright protection.** (p. 65)

**Cannot add audio. Disconnect the i.LINK cable.** (p. 51)

**Not recorded in SP mode. Cannot add audio.** (p. 51)

**Not recorded in 12-bit audio. Cannot add audio.** (p. 51)

**Cannot add audio on the blank portion of a tape.** (p. 51)

**Cannot add audio.** (p. 51)

- You cannot add sound to a tape recorded on other devices by 4CH MIC REC.

**☒ Dirty video head. Use a cleaning cassette.** (p. 69)

**Cannot start Easy Handycam.** (p. 22, 54)

**Cannot cancel Easy Handycam.** (p. 22, 54)

---

**Invalid during Easy Handycam operation.** (p. 23)

---

**HDV recorded tape. Cannot playback.**

- Your camcorder cannot play back this format. Play back the tape with the equipment that recorded it.
- 

**HDV recorded tape. Cannot add audio.**

- Your camcorder does not allow you to add audio on a section of a tape recorded in HDV format (p. 51).
-

# Using your camcorder abroad

## Power supply

You can use your camcorder in any country/region using the AC Adaptor supplied with your camcorder within the AC 100 V to 240 V, 50/60 Hz range. Use a commercially available AC plug adaptor [a], if necessary, depending on the design of the wall outlet [b].



## On TV color systems

Your camcorder is NTSC system, so its picture can only be viewed on a NTSC system TV with an AUDIO/VIDEO input jack.

System	Used in
NTSC	Bahama Islands, Bolivia, Canada, Central America, Chile, Colombia, Ecuador, Guyana, Jamaica, Japan, Korea, Mexico, Peru, Surinam, Taiwan, the Philippines, the U.S.A., Venezuela, etc.
PAL	Australia, Austria, Belgium, China, Czech Republic, Denmark, Finland, Germany, Holland, Hong Kong, Hungary, Italy, Kuwait, Malaysia, New Zealand, Norway, Poland, Portugal, Singapore, Slovak Republic, Spain, Sweden, Switzerland, Thailand, United Kingdom, etc.
PAL - M	Brazil
PAL - N	Argentina, Paraguay, Uruguay.
SECAM	Bulgaria, France, Guiana, Iran, Iraq, Monaco, Russia, Ukraine, etc.

## Simple setting of the clock by time difference

You can easily set the clock to local time abroad by the time difference you are in. Select [WORLD TIME] in the **ETC** (OTHERS) menu, then set the time difference (p. 47).



# Usable cassette tapes

You can use mini DV format cassettes only. Use a cassette with the **Mini DV** mark. Your camcorder is not compatible with the Cassette Memory function.

## To prevent a blank section from being created on the tape

Go to the end of the recorded section using **END SEARCH** (p. 30) before you begin the next recording in the following cases:

- You have played back the tape.
- You have used **EDIT SEARCH**.

## Copyright signal

### ■ When you play back

If the cassette you play back on your camcorder contains copyright signals, you cannot copy it to a tape in another video camera connected to your camcorder.

### ■ When you record

You cannot record software on your camcorder that contains copyright control signals for copyright protection of software. [Cannot record due to copyright protection.] appears on the LCD screen, or on the viewfinder if you try to record such software. Your camcorder does not record copyright control signals on the tape when it records.

## Notes on use

### ■ When not using your camcorder for a long time

Remove the cassette and store it.

### ■ To prevent accidental erasure

Slide the write-protect tab on the cassette to set it to **SAVE**.



**REC:** The cassette can be recorded.

**SAVE:** The cassette cannot be recorded (write-protected).



### ■ When labeling the cassette

Be sure to place the label only on the locations shown in the following illustration so as not to cause a malfunction of your camcorder.

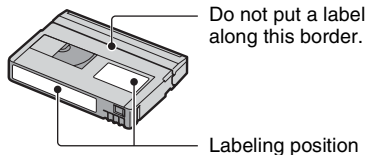

### ■ After using the cassette

Rewind the tape to the beginning to avoid distortion of the picture or the sound. The cassette should then be put in its case, and stored in an upright position.

### ■ When cleaning the gold-plated connector

Generally, clean the gold-plated connector on a cassette with a cotton-wool swab after every 10 times it has been ejected. If the gold-plated connector on the cassette is dirty or dusty, the remaining tape indicator may not show correctly.

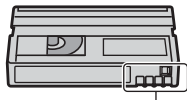

Gold-plated connector

# About the “InfoLITHIUM” battery pack

This unit is compatible with an “InfoLITHIUM” battery pack (P series/H series).

Your camcorder operates only with an “InfoLITHIUM” battery pack.

“InfoLITHIUM” P series battery packs have the  mark.

“InfoLITHIUM” H series battery packs have the  mark.

## What is an “InfoLITHIUM” battery pack?

An “InfoLITHIUM” battery pack is a lithium-ion battery pack that has functions for communicating information related to operating conditions between your camcorder and an optional AC Adaptor/charger.

The “InfoLITHIUM” battery pack calculates the power consumption according to the operating conditions of your camcorder, and displays the remaining battery time in minutes.

## To charge the battery pack

- Be sure to charge the battery pack before you start using your camcorder.
- We recommend charging the battery pack in an ambient temperature of between 10 °C to 30 °C (50 °F to 86 °F) until the CHG (charge) lamp turns off. If you charge the battery pack outside of this temperature range, you may not be able to charge it efficiently.
- When charging the battery pack while the AC Adaptor is connected to your camcorder, after charging is complete, disconnect the cable from the DC IN jack on your camcorder or remove the battery pack.

## To use the battery pack effectively

- Battery pack performance decreases when the surrounding temperature is 10 °C (50 °F) or below, and the length of time you can use the battery pack becomes shorter. In that case, do one of the following to use the battery pack for a longer time.
  - Put the battery pack in a pocket to warm it up, and insert it in your camcorder right before you start taking shots.

– Use a large capacity battery pack: NP-FP71/FP90/FH70/FH100 (optional).

- Frequent use of the LCD screen or a frequent playback, fast forward or rewind operation wears out the battery pack faster.  
We recommend using a large capacity battery pack: NP-FP71/FP90/FH70/FH100 (optional).
- Be sure to set the POWER switch to OFF(CHG) when not recording or playing back on your camcorder. The battery pack is also consumed when your camcorder is in recording standby or playback pause.
- Have spare battery packs ready for two or three times the expected recording time, and make trial recordings before making the actual recording.
- Do not expose the battery pack to water. The battery pack is not water resistant.

## About the remaining battery time indicator

- When the power goes off even though the remaining battery time indicator indicates that the battery pack has enough power to operate, charge the battery pack fully again. Remaining battery time will be indicated correctly. Note, however, that the battery indication will not be restored if it is used in high temperatures for a long time, or if left in a fully charged state, or when the battery pack is frequently used. Use the remaining battery time indication as a rough guide only.
- The  mark that indicates low battery flashes even if there are still 5 to 10 minutes of battery time remaining, depending on the operating conditions or ambient temperature.

## About storage of the battery pack

- If the battery pack is not used for a long time, fully charge the battery pack and use it up on your camcorder once a year to maintain proper function. To store the battery pack, remove it from your camcorder and put it in a dry, cool place.
- To discharge the battery pack on your camcorder completely, set [A.SHUT OFF] to [NEVER] on the  (OTHERS) menu and leave your camcorder in tape recording standby until the power goes off (p. 47).

# About i.LINK

## About battery life

- Battery capacity decreases over time and through repeated use. If decreased usage time between charges becomes significant, it is probably time to replace it with a new one.
- Each battery's life is governed by storage, operating and environmental conditions.

The DV Interface on this unit is an i.LINK-compliant DV Interface. This section describes the i.LINK standard and its features.

## What is i.LINK?

i.LINK is a digital serial interface for transferring digital video, digital audio, and other data to other i.LINK-compatible devices. You can also control other devices using the i.LINK.

i.LINK-compatible devices can be connected using an i.LINK cable. Possible applications are operations and data transactions with various digital AV devices.

When two or more i.LINK-compatible devices are daisy-chained with the unit, operation becomes possible from any device in the chain. Note that operation method may vary, or data transactions may not be possible, depending on specifications and characteristics of the connected devices.

- Normally, only one device can be connected to this unit with an i.LINK cable. When connecting this unit to an i.LINK-compatible device having two or more DV Interfaces, refer to the operating instructions of the device to be connected.
- i.LINK is a more familiar term for the IEEE 1394 data transport bus proposed by Sony, and is a trademark approved by many corporations.
- IEEE 1394 is an international standard standardized by the Institute of Electrical and Electronics Engineers.

## About the i.LINK Baud rate

i.LINK's maximum baud rate varies according to the device. There are 3 types.

S100 (approx. 100Mbps\*)

S200 (approx. 200Mbps)

S400 (approx. 400Mbps)

The baud rate is listed under “Specifications” in the operating instructions of each piece of equipment. It is also indicated near the i.LINK interface on some devices.

The baud rate may differ from the indicated value when the unit is connected to a device with a different maximum baud rate.

### \* What is Mbps?

Mbps stands for “megabits per second,” or the amount of data that can be sent or received in one second. For example, a baud rate of 100 Mbps means that 100 megabits of data can be sent in one second.

## To use i.LINK functions on this unit

For details on how to dub when this unit is connected to other video devices having a DV Interface, see page 48, 50.

This unit can also be connected to other i.LINK (DV Interface) compatible devices made by Sony (e.g. a VAIIO series personal computer) as well as to video devices.

Some i.LINK compatible video devices, such as Digital Televisions, DVD, MICROMV or HDV recorders/players are not compatible with DV devices. Before connecting to other devices, be sure to confirm whether the device is compatible with a DV device or not. For details on precautions and compatible application software, refer also to the operating instructions for the device to be connected.

- When you connect this unit to a device equipped with an i.LINK jack using an i.LINK cable, power off the device and remove the power cord from the wall outlet before connecting (or disconnecting) an i.LINK cable.

## About the required i.LINK cable

Use the Sony i.LINK 4-pin-to-4-pin cable (during DV dubbing).

# Maintenance and precautions

## On use and care



- Do not use or store the camcorder and accessories in the following locations.
  - Anywhere extremely hot or cold. Never leave them exposed to temperatures above 60 °C (140 °F), such as under direct sunlight, near heaters or in a car parked in the sun. They may malfunction or become deformed.
  - Near strong magnetic fields or mechanical vibration. The camcorder may malfunction.
  - Near strong radio waves or radiation. The camcorder may not be able to record properly.
  - Near AM receivers and video equipment. Noise may occur.
  - On a sandy beach or anywhere dusty. If sand or dust gets in your camcorder, it may malfunction. Sometimes this malfunction cannot be repaired.
  - Near windows or outdoors, where the LCD screen, the viewfinder, or the lens may be exposed to direct sunlight. This damages the inside of the viewfinder or the LCD screen.
  - Anywhere very humid.
- Operate your camcorder on DC 7.2 V (battery pack) or DC 8.4 V (AC Adaptor).
- For DC or AC operation, use the accessories recommended in these operating instructions.
- Do not let your camcorder get wet, for example, from rain or sea water. If your camcorder gets wet, it may malfunction. Sometimes this malfunction cannot be repaired.
- If any solid object or liquid gets inside the casing, unplug your camcorder and have it checked by a Sony dealer before operating it any further.
- Avoid rough handling, disassembling, modifying, physical shock, or impact such as hammering, dropping or stepping on the product. Be particularly careful of the lens.
- Keep the POWER switch setting to OFF(CHG) when you are not using your camcorder.
- Do not wrap your camcorder with a towel, for example, and operate it. Doing so might cause heat to build up inside.
- When disconnecting the power cord, pull it by the plug and not the cord.
- Do not damage the power cord such as by placing anything heavy on it.
- Keep metal contacts clean.

- If the battery electrolytic liquid has leaked,
  - consult your local authorized Sony service facility.
  - wash off any liquid that may have contacted your skin
  - if any liquid gets in your eyes, wash with plenty of water and consult a doctor.

### ■ When not using your camcorder for a long time



- Periodically turn on the camcorder and play a cassette for about 3 minutes.
- Use up the battery pack completely before storing it.

### Moisture condensation

If your camcorder is brought directly from a cold place to a warm place, moisture may condense inside your camcorder, on the surface of the tape, or on the lens. In this state, the tape may stick to the head drum and be damaged or your camcorder may not operate correctly. If there is moisture inside your camcorder, []  Moisture condensation. Eject the cassette] or [] Moisture condensation. Turn off for 1H.] appears. The indicator will not appear when the moisture condenses on the lens.

### ■ If moisture condensation has occurred

None of the functions except cassette ejection will work. Eject the cassette, turn off your camcorder, and leave it for about one hour with the cassette lid open. Your camcorder can be used again when both of the following conditions are met:

- The warning message does not appear when the power is turned on.
- Neither  or  flash when a cassette is inserted and video operation buttons are touched.

If moisture starts to condense, your camcorder sometimes cannot detect condensation. If this happens, the cassette is sometimes not ejected for 10 seconds after the cassette lid is opened. This is not a malfunction. Do not close the cassette lid until the cassette is ejected.

### ■ Note on moisture condensation

Moisture may condense when you bring your camcorder from a cold place into a warm place (or vice versa) or when you use your camcorder in a humid place as shown below.

- When you bring your camcorder from a ski slope into a place warmed up by a heating device.
- When you bring your camcorder from an air conditioned car or room into a hot place outside.
- When you use your camcorder after a squall or a shower.
- When you use your camcorder in a hot and humid place.

### ■ How to avoid moisture condensation

When you bring your camcorder from a cold place into a warm place, put your camcorder in a plastic bag and seal it tightly. Remove the bag when the air temperature inside the plastic bag has reached the surrounding temperature (after about one hour).

### Video head

- If the video heads are dirty, video or sound distortion may be apparent.
- If the following problem occurs, clean the video heads for 10 seconds with the Sony DVM-12CLD cleaning cassette (optional).
  - Mosaic-pattern noise appears on the playback picture or the screen is displayed in blue.



- Playback pictures do not move.
- Playback pictures do not appear or the sound breaks off.
- [] Dirty video head. Use a cleaning cassette.] appears on the screen during recording/playback.

## Maintenance and precautions (Continued)

- The video heads will wear after long use. If you cannot obtain a clear image even after using a cleaning cassette (optional), it might be because the video heads are worn. Please contact your Sony dealer or local authorized Sony service facility to have the video heads replaced.

### LCD screen

- Do not exert excessive pressure on the LCD screen, as it may cause damage.
- If your camcorder is used in a cold place, a residual image may appear on the LCD screen. This is not a malfunction.
- While using your camcorder, the back of the LCD screen may heat up. This is not a malfunction.

#### ■ To clean the LCD screen

If fingerprints or dust make the LCD screen dirty, it is recommended you use a soft cloth to clean it. When you use the LCD Cleaning Kit (optional), do not apply the cleaning liquid directly to the LCD screen. Use cleaning paper moistened with the liquid.

#### ■ On adjustment of the LCD screen (CALIBRATION)

The buttons on the touch panel may not work correctly. If this happens, follow the procedure below. It is recommended you connect your camcorder to the wall outlet using the supplied AC Adaptor during the operation.

- ① Slide the POWER switch to OFF(CHG).
- ② Eject the cassette from your camcorder, then disconnect any connecting cables except the AC Adaptor from your camcorder.
- ③ Slide the POWER switch repeatedly to turn on the PLAY/EDIT lamp while pressing DISP/BATT INFO on your camcorder, and keep pressing down DISP/BATT INFO for about 5 seconds.

- ④ Touch the “x” displayed on the screen with the corner of the “Memory Stick” or the like.

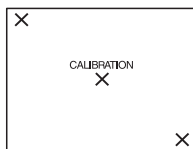

The position of the “x” changes. If you did not press the right spot, start from step ④ again.

- You cannot calibrate the LCD screen if it is rotated.

### On handling the casing

- If the casing is soiled, clean the camcorder body with a soft cloth lightly moistened with water, and then wipe the casing with a dry soft cloth.
- Avoid the following to avoid damage to the finish.
  - Using chemicals such as thinner, benzine, alcohol, chemical cloths, repellent, insecticide and sunscreen.
  - Handling with above substances on your hands.
  - Leaving the casing in contact with rubber or vinyl objects for a long period of time.

### About care and storage of the lens

- Wipe the surface of the lens clean with a soft cloth in the following instances:
  - When there are fingerprints on the lens surface.
  - In hot or humid locations
  - When the lens is exposed to salty air such as at the seaside.
- Store in a well-ventilated location subject to little dirt or dust.
- To prevent mold, periodically clean the lens as described above. It is recommended that you operate your camcorder about once a month to keep it in optimum state for a long time.

# Specifications

## On charging the pre-installed rechargeable battery

Your camcorder has a pre-installed rechargeable battery to retain the date, time, and other settings even when the POWER switch is set to OFF(CHG). The pre-installed rechargeable battery is always charged while your camcorder is connected to the wall outlet via the AC Adaptor or while the battery pack is attached. The rechargeable battery will be fully discharged in about **3 months** if you do not use your camcorder at all without the AC Adaptor connected or the battery pack attached. Use your camcorder after charging the pre-installed rechargeable battery.

However, even if the pre-installed rechargeable battery is not charged, the camcorder operation will not be affected as long as you are not recording the date.

### ■ Procedures

Connect your camcorder to a wall outlet using the supplied AC Adaptor, and leave it with the POWER switch set to OFF(CHG) for more than 24 hours.

## System

### Video recording system

2 rotary heads, Helical scanning system

### Audio recording system

Rotary heads, PCM system

Quantization: 12 bits (Fs 32 kHz, stereo 1, stereo 2), 16 bits (Fs 48 kHz, stereo)

### Video signal

NTSC color, EIA standards

### Usable cassette

Mini DV cassette with the <sup>Mini</sup> DV mark printed

### Tape speed

SP: Approx. 18.81 mm/s

LP: Approx. 12.56 mm/s

### Recording/playback time

SP: 60 min (using a DVM60 cassette)

LP: 90 min (using a DVM60 cassette)

### Fast forward/rewind time

Approx. 2 min 40 s (using a DVM60 cassette and rechargeable battery pack)

Approx. 1 min 45 s (using a DVM60 cassette and AC Adaptor)

### Viewfinder

Electric viewfinder (color)

### Image device

3.0 mm (1/6 type) CCD (Charge Coupled Device)

Gross: Approx. 680 000 pixels

Effective (movie): Approx. 340 000 pixels

### Lens

Carl Zeiss Vario-Tessar

20 × (Optical), 800 × (Digital)

### Focal length

f=2.3 ~ 46 mm (3/32 ~ 1 13/16 in.)

When converted to a 35 mm still camera

In CAMERA: 44 ~ 880 mm (1 3/4 ~ 34 1/32 in.)

F1.8 ~ 3.1

Filter diameter: 25 mm (1 in.)

## Specifications (Continued)

### Color temperature

[AUTO], [ONE PUSH], [INDOOR]  
(3 200 K), [OUTDOOR] (5 800 K)

### Minimum illumination

5 lx (lux) (F 1.8)  
0 lx (lux) (during NightShot plus  
function)

### Input/Output connectors

#### Audio/Video output

10-pin connector  
Video signal: 1 Vp-p, 75  $\Omega$  (ohms),  
unbalanced  
Luminance signal: 1 Vp-p, 75  $\Omega$   
(ohms), unbalanced  
Chrominance signal: 0.286 Vp-p, 75  $\Omega$   
(ohms), unbalanced  
Audio signal: 327 mV (at load  
impedance 47 k $\Omega$  (kilohms)), Output  
impedance with less than 2.2 k $\Omega$   
(kilohms)

#### DV input/output

i.LINK Interface (IEEE1394, 4-pin  
connector S100)

### LCD screen

#### Picture

6.2 cm (2.5 type)

#### Total dot number

123 200 (560  $\times$  220)

### General

#### Power requirements

DC 6.8 V/7.2 V (battery pack)  
DC 8.4 V (AC Adaptor)

#### Average power consumption

During camera recording using the  
viewfinder 1.8 W  
During camera recording using the  
LCD 2.1 W

#### Operating temperature

0  $^{\circ}$ C to 40  $^{\circ}$ C (32  $^{\circ}$ F to 104  $^{\circ}$ F)

#### Storage temperature

-20  $^{\circ}$ C to + 60  $^{\circ}$ C (-4  $^{\circ}$ F to + 140  $^{\circ}$ F)

#### Dimensions (approx.)

65  $\times$  79  $\times$  113 mm  
(2 5/8  $\times$  3 1/8  $\times$  4 1/2 in.) (w/h/d)  
(including the projecting parts)  
65  $\times$  79  $\times$  113 mm  
(2 5/8  $\times$  3 1/8  $\times$  4 1/2 in.) (w/h/d)  
(including the projecting parts with  
supplied battery pack NP-FP30  
attached)

#### Mass (approx.)

360 g (12 oz) main unit only  
420 g (14 oz) including the NP-FP30  
rechargeable battery pack and DVM60  
cassette.

#### Supplied accessories

See page 11.

### AC Adaptor AC-L25A/L25B

#### Power requirements

AC 100 - 240 V, 50/60 Hz

#### Current consumption

0.35 - 0.18 A

#### Power consumption

18 W

#### Output voltage

DC 8.4 V\*

#### Operating temperature

0  $^{\circ}$ C to 40  $^{\circ}$ C (32  $^{\circ}$ F to 104  $^{\circ}$ F)

#### Storage temperature

-20  $^{\circ}$ C to + 60  $^{\circ}$ C (-4  $^{\circ}$ F to + 140  $^{\circ}$ F)

#### Dimensions (approx.)

56  $\times$  31  $\times$  100 mm (2 1/4  $\times$  1 1/4  $\times$  4 in.)  
(w/h/d) excluding the projecting parts

#### Mass (approx.)

190 g (6.7 oz) excluding the power cord

\* See the label on the AC Adaptor for  
other specifications.



## Rechargeable battery pack (NP-FP30)

### Maximum output voltage

DC 8.4 V

### Output voltage

DC 7.2 V

### Capacity

3.6 Wh (500 mAh)

### Dimensions (approx.)

31.8 × 18.5 × 45.0 mm

(1 5/16 × 3/4 × 1 13/16 in) (w/h/d)

### Mass (approx.)

40 g (1.5 oz)

### Operating temperature



0 °C to 40 °C (32 °F to 104 °F)

### Type

Lithium ion

Design and specifications are subject to change without notice.

## On trademarks

- “InfoLITHIUM” is a trademark of Sony Corporation.
- i.LINK and  are trademarks of Sony Corporation.
- Mini  is a trademark.
- “Handycam” and  are registered trademarks of Sony Corporation.
- Microsoft, Windows, and Windows Media are trademarks or registered trademarks of U.S. Microsoft Corporation in the U.S. and other countries.

All other product names mentioned herein may be the trademarks or registered trademarks of their respective companies. Furthermore, <sup>TM</sup> and “®” are not mentioned in each case in this manual.

# Index

## Numeric

12BIT.....	46
16BIT.....	46
16:9 WIDE.....	44
4:3.....	44

## A

A DUB CTRL (Audio dubbing).....	52
AC Adaptor.....	12
Adjusting exposure for back light.....	26, 57
AUDIO MIX.....	52
AUDIO MODE.....	46
AUTO SHTR (Auto shutter).....	43
A.SHUT OFF (Auto shut off).....	47
A/V connecting cable.....	32, 48
A/V OUT jack.....	32, 48

## B

BACK LIGHT.....	26, 57
BATT (battery) release lever .....	13
Battery	
Battery info.....	27
Battery pack.....	12
Charging time.....	13
Playing time.....	14
Recording time.....	13
Remaining battery.....	28
BEACH&SKI.....	42
BEEP.....	47
BLACK.....	37
B&W.....	43

## C

CALIBRATION.....	70
CAM DATA.....	39
CAMERA SET menu.....	43

Cassette.....	20, 65
Insert/Eject.....	20
Write-protect tab.....	65
Cassette compartment.....	20
Charging the battery.....	12
Battery pack.....	12
Pre-installed rechargeable battery.....	71
Charging time.....	13
CHG (charge) lamp.....	12
CLOCK SET.....	19
Connect	
TV.....	32, 50
VCR.....	32, 48, 50

## D

D ZOOM (Digital zoom).....	43
DATA CODE.....	28, 39
DATE/TIME.....	19, 28, 39
DC IN jack.....	12
DC plug.....	12
DEMO MODE.....	47, 54
DISP GUIDE (Display guide).....	17
DISP OUT (Display output).....	47
Display indicators.....	28
DISP/BATT INFO button .....	17, 27
Double speed Playback.....	40
Dubbing.....	48, 51
DV Interface.....	48, 50, 53

## E

EASY button.....	22
Easy Handycam.....	22, 35
EDITSEARCH.....	30, 44
END SCH (END SEARCH).....	30, 57
EXPOSURE.....	38, 59

## F

FADER.....	37
Fireworks.....	42
Flexible spot meter .....	See SPOT METER
FN (Function) button.....	28, 34
FOCUS.....	36, 57
Frame-by-frame Playback.....	40
Full charge.....	13

## G

Getting started.....	11
Grip belt.....	15

## H

Holding the camcorder.....	15
----------------------------	----

## I

Icon.....	See Display indicators
ID-1/ID-2.....	44
Indicators.....	29
INDOOR.....	38
“InfoLITHIUM” battery pack .....	66
Infrared port.....	26
Initialize (Reset).....	27
Internal stereo microphone.....	27
i.LINK.....	67
i.LINK cable.....	48, 50

## J

Jack.....	53
-----------	----

## L

Label.....	65
LANDSCAPE.....	42
LANGUAGE.....	47
LCD.....	47
LCD BRT (LCD bright).....	39
LCD B.L. (LCD back light).....	45

LCD COLOR.....	45
LCD panel.....	16
LCD screen.....	16
LCD/VF SET menu.....	45
Lens cap.....	11, 15, 22
LETTER BOX.....	46
Lid.....	20
LP (Long Play).....	46

## M

Maintenance.....	68
MANUAL SET menu.....	42
Menu.....	34
CAMERA SET menu.....	43
LCD/VF SET menu.....	45
MANUAL SET menu.....	42
Menu items.....	41
OTHERS menu.....	47
SETUP MENU menu.....	47
TAPE SET menu.....	46
Using the menu.....	34
VCR SET menu.....	45
Mirror mode.....	27
Moisture condensation.....	69
MONOTONE.....	37
MOSAIC.....	43
MOSC. FADER.....	37
Movie	
REC MODE (Recording mode).....	46

## N

NEG.ART.....	42
NightShot plus.....	26
NIGHTSHOT PLUS switch .....	26
NTSC.....	59, 64
N.S.LIGHT (NightShot Light).....	44

## O

ONE PUSH.....	38
OPEN/EJECT lever.....	20
Operation button.....	34
Operation confirmation beep .....	See BEEP
OTHERS menu.....	47
OUTDOOR.....	38

## P

P EFFECT (Picture effect).....	42
PAL.....	64
PASTEL.....	43
Picture Search.....	25
Playback.....	25
Double speed.....	40
Frame.....	40
Reverse.....	40
Slow.....	40
Playing time.....	14
PORTRAIT (Soft portrait).....	42
Power cord.....	12
POWER switch.....	12, 15
Pre-installed rechargeable battery.....	71
PROGRAM AE.....	42, 59

## R

REC CTRL (Recording control).....	50
REC MODE (Recording mode).....	46
Rec review.....	31
REC START/STOP button .....	22, 24
Rechargeable battery pack .....	See Battery
Recording.....	24
Recording capacity.....	28
Recording time.....	13
REMAIN.....	46
RESET button.....	27

Reversal Playback.....	40
------------------------	----

## S

S VIDEO cable.....	32, 48
S VIDEO jack.....	32, 48
Searching for the starting point .....	30
Self-diagnosis display.....	61
SEPIA.....	43
Setting the date and time.....	19
SETUP MENU menu.....	47
Shoulder Belt.....	27
Skip Scan.....	25
Slow Playback.....	40
SOLARIZE.....	43
SP (Standard Play).....	46
Speaker.....	27
Specifications.....	71
SPORTS (Sports lesson).....	42
SPOT FOCUS.....	36, 59
SPOT METER (Flexible spot meter).....	36, 59
SPOTLIGHT.....	42
SQUEEZE.....	46
STEADYSHOT.....	44, 57
SUNSETMOON.....	42

## T

Tape counter.....	28
TAPE SET menu.....	46
Tape.....	See Cassette
Telephoto.....	26
Time code.....	28
Touch panel.....	17
Trademark.....	73
Tripod.....	27
TV.....	32, 50
TV color systems.....	64

## U

Using abroad.....	64
-------------------	----

## Index (Continued)

### V

V SPD PLAY (Various speed playback) .....	40
VCR SET menu .....	45
VF B.L. (Viewfinder back light) .....	46
Video head.....	69
Video operation buttons .....	28
Viewfinder.....	16
Back light .....	46
Viewfinder lens adjustment lever .....	16
VOL (Volume) .....	25
V-OUT/LCD .....	47

### W

Wall outlet .....	12
Warning indicators .....	61
Warning messages .....	62
WHITE .....	37
WHT BAL (White balance) .....	38, 59
Wide angle.....	26
WIDE DISP (Wide display) .....	46
WIDE SEL (Wide select).....	44
WORLD TIME.....	47
Write-protect tab.....	65

### Z

Zoom .....	26
Zoom lever .....	26

# Paso 1: Comprobación de los elementos suministrados

Asegúrese de que su videocámara contiene los siguientes elementos.

El número entre paréntesis indica la cantidad del elemento.

Adaptador de alimentación de ca (1)

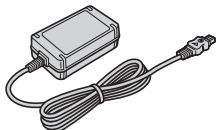

Cable de alimentación (1)



Cable de conexión A/V (1)

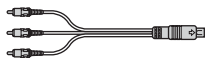

Tapa del objetivo (1)



• Para instalar la tapa del objetivo

Acople la tapa del objetivo a los adaptadores de metal de la correa de sujeción, como se ilustra a continuación, utilizando la bandolera.

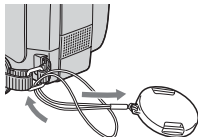

Batería recargable NP-FP30 (1)

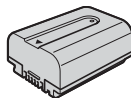

Guía de operaciones (Este manual) (1)

## Paso 2: Carga de la batería

Para cargar la batería "InfoLITHIUM" (serie P/serie H), conéctela a la videocámara.

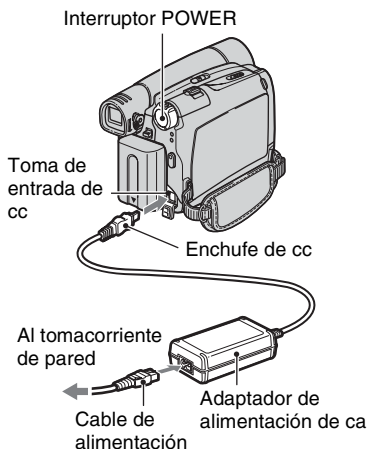

**1** Alinee los terminales de la batería y de su videocámara ①, luego coloque la batería y cárcela en su lugar ②.

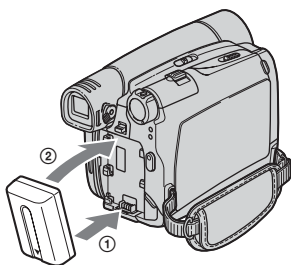

**2** Deslice el interruptor POWER en el sentido de la flecha hasta la posición OFF(CHG) (Ajuste predeterminado).



**3** Conecte el adaptador de alimentación de ca a la toma de entrada de cc de la videocámara.

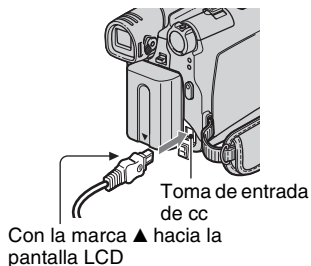

**4** Conecte el cable de alimentación al adaptador de alimentación de ca y al tomacorriente de pared.

El indicador CHG (carga)

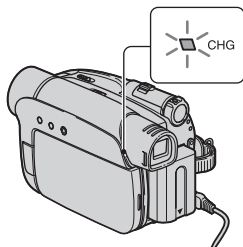

El indicador CHG (carga) se enciende y se inicia el proceso de carga.

## 5 El indicador CHG (carga) se apaga cuando la batería está completamente cargada. Desconecte el adaptador de alimentación de ca de la toma de entrada de cc

Desconecte el adaptador de alimentación de ca de la toma de entrada de cc sujetando a la vez la videocámara y la clavija de cc

## Para utilizar una fuente de alimentación externa

Puede utilizar la cámara mediante la alimentación del tomacorriente de pared realizando las mismas conexiones que cuando carga la batería. La batería no perderá la carga en este caso.

## Para retirar la batería

- Deslice el interruptor POWER hasta la posición OFF(CHG). Mantenga presionado con una mano el botón de liberación ▼ BATT (batería).
- Extraiga la batería con la otra mano en el sentido de la flecha.

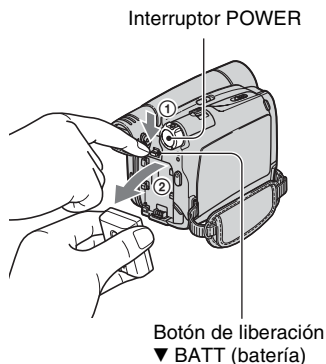

## Cuando guarde la batería

Descargue completamente la batería antes de guardarla durante un período prolongado.

## Tiempo de carga

Tiempo aproximado (min) necesario para cargar totalmente una batería descargada por completo.

Batería	Tiempo de carga
NP-FP30 (suministrado)	115
NP-FP50	125
NP-FP71	170
NP-FP90	220
NP-FH50	135
NP-FH70	170
NP-FH100	390

## Tiempo de grabación

Tiempo aproximado (min) disponible cuando utiliza una batería completamente cargada.

Batería	Tiempo de grabación continua	Tiempo de grabación normal*
NP-FP30 (suministrado)	95 110	45 55
NP-FP50	135 160	65 80
NP-FP71	330 395	165 195
NP-FP90	500 580	250 290
NP-FH50	155 180	75 90
NP-FH70	330 395	165 195
NP-FH100	760 890	380 445

## Paso 2: Carga de la batería (Continuación)

- Todo el tiempo calculado en las siguientes condiciones:  
Parte superior: Grabación con pantalla LCD.  
Parte inferior: Grabación con el visor mientras el panel LCD se encuentra cerrado.
- \* El tiempo de grabación normal muestra la hora cuando se repite la operación de inicio/detención de la grabación, al conectar y desconectar la alimentación y al usar la función de zoom.

### Tiempo de reproducción

Tiempo aproximado (min) disponible cuando utiliza una batería completamente cargada.

Batería	Panel LCD abierto	Panel LCD cerrado
NP-FP30 (suministrado)	105	135
NP-FP50	150	190
NP-FP71	370	465
NP-FP90	550	705
NP-FH50	170	220
NP-FH70	370	465
NP-FH100	845	1065

### Acerca de la batería

- Antes de cambiar la batería, deslice el interruptor POWER a la posición OFF(CHG).
- El indicador CHG (carga) parpadeará durante la carga o la información de la batería no se mostrará correctamente en las siguientes condiciones.
  - La batería no está correctamente conectada.
  - La batería está dañada.
  - La batería está completamente desgastada. (Sólo para la información de la batería.)
- Cuando el adaptador de alimentación de ca esté conectado a la toma de entrada de cc de la videocámara, la batería no suministrará alimentación, incluso si el cable de alimentación está desconectado al tomacorriente de pared.

### Acerca del tiempo de carga/grabación/reproducción

- Tiempo calculado con la videocámara a 25 °C (Se recomienda de 10 °C a 30 °C)

- El tiempo de grabación y de reproducción será más corto cuando use la videocámara a bajas temperaturas.
- El tiempo de grabación y de reproducción será más corto en función de las condiciones de uso de la videocámara.

### Acerca del adaptador de alimentación de ca

- Si utiliza el adaptador de alimentación de ca conéctelo a un tomacorriente de pared cercano. Si se produce alguna falla de funcionamiento al utilizar la videocámara, desconecte el adaptador de alimentación de ca del tomacorriente de inmediato.
- No utilice el adaptador de alimentación de ca colocado en un espacio angosto, tal como entre una pared y los muebles.
- Evite la formación de cortocircuitos en la clavija de cc del adaptador de alimentación de ca o en el terminal de la batería con objetos metálicos. Esto podría provocar una falla de funcionamiento.

### PRECAUCIÓN

- Aunque la videocámara esté apagada, seguirá recibiendo adaptador de alimentación de ca (corriente doméstica) mientras esté conectada a la toma de pared mediante el adaptador de alimentación de ca



# Paso 3: Encendido y sujeción de la videocámara con firmeza

Para grabar o reproducir, deslice varias veces el interruptor POWER hasta que se encienda el indicador respectivo.

Al utilizarla por primera vez, aparecerá la pantalla [AJ. RELOJ].

Interruptor POWER Tapa del objetivo

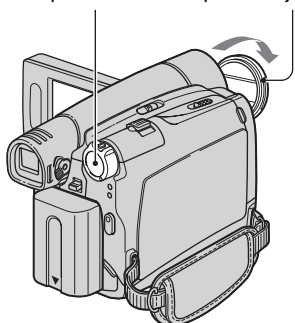

**1** Extraer la tapa del objetivo presionando ambas palancas en los laterales de la tapa.

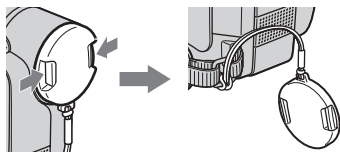

**2** Deslice el interruptor POWER varias veces en el sentido de la flecha para que se encienda el indicador correspondiente.

Si el interruptor POWER está en la posición OFF(CHG), deslícelo mientras presiona el botón verde.

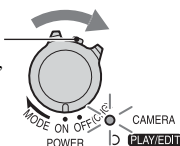

**Indicadores que se encienden**

**CAMERA:** Para grabar en una cinta.

**PLAY/EDIT:** Para reproducir o editar imágenes.

- Luego de ajustar la fecha y la hora ([AJ. RELOJ]), la próxima vez que encienda su videocámara, la fecha y hora actual aparecerán en la pantalla LCD durante algunos s (segundo).

**3** Sostenga la videocámara correctamente.

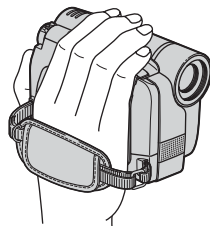

**4** Asegúrese de que la sostiene correctamente y luego ajuste la correa de sujeción.

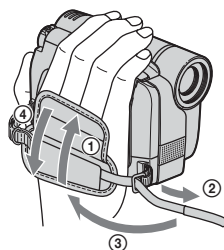

**Para apagar la videocámara**

- ① Deslice el interruptor POWER hasta la posición OFF(CHG).
- ② Acople la tapa del objetivo.

- Al momento de la compra, la alimentación se ajusta para desconectarse automáticamente si no se opera la videocámara durante unos 5 min (minuto) para ahorrar energía de la batería ([APAG. AUTO]).

## Paso 4: Ajuste del panel LCD y el visor

### El panel LCD

Abra el panel LCD a 90 grados con respecto a la videocámara (①), luego gírelo hacia el mejor ángulo para grabar o reproducir (②).

180 grados  
(máx.)

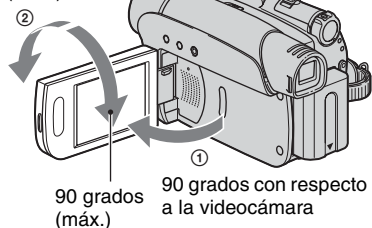

- Si gira el panel LCD 180 grados hacia el lado del objetivo, podrá cerrarlo con la pantalla LCD hacia afuera. Esto resulta conveniente durante operaciones de reproducción.
- Consulte [BRIL LCD] para ajustar el brillo de la pantalla LCD.

### El visor

Puede ver imágenes utilizando el visor para evitar el desgaste de la batería o cuando la imagen en la pantalla LCD es mala.

Visor

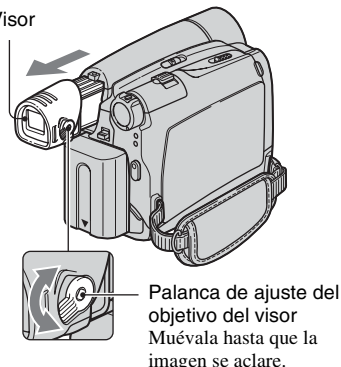

- Puede ajustar el brillo de fondo del visor seleccionando (AJ LCD/VIS) - [LUZ F. VIS].
- Puede ajustar los valores de [AU GR DESV] y de [EXPOSIC.] con el visor.

# Paso 5: Uso del panel sensible al tacto

Puede reproducir imágenes grabadas o cambiar los ajustes con el panel sensible al tacto.

**Coloque la mano en la parte posterior del panel LCD para sostenerlo. A continuación, toque los botones que se muestran en la pantalla.**

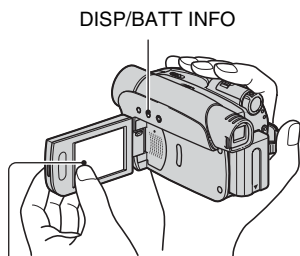

Toque los botones de la pantalla LCD.

- Si los botones del panel sensible al tacto no funcionan correctamente, ajuste la pantalla LCD (CALIBRACIÓN).
- Pueden aparecer líneas de puntos en la pantalla LCD, lo que no significa una falla de funcionamiento. Estos puntos no se graban.

## Para ocultar los indicadores de pantalla

Presione DISP/BATT INFO para activar o desactivar los indicadores de pantalla (como el código de tiempo).

## Cambio de los ajustes de idioma

Puede cambiar las indicaciones en pantalla para mostrar mensajes en un idioma en particular. Toque [FN] → [MENU] → [AJUS. MENÚ] → [LANGUAGE] para seleccionar el idioma de la pantalla.

## Comprobación de los indicadores de pantalla (Vista guía)

Puede comprobar fácilmente el significado de cada indicador que aparece en la pantalla LCD.

### 1 Toque [FN].

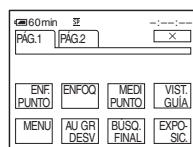

### 2 Toque [VIST. GUÍA].



Los indicadores varían en función de los ajustes.

### 3 Toque el área que incluye el indicador que desea comprobar.

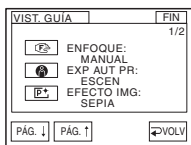

Los significados de los indicadores del área se muestran en la pantalla. Si no puede encontrar el indicador que desea comprobar, toque [PÁG. ↓]/[PÁG. ↑] para activarlos o desactivarlos.

Cuando toque [↔ VOLV], la pantalla volverá a la visualización de selección del área.

### Para finalización la operación

Toque [FIN].

# Paso 6: Ajuste de la fecha y la hora

Ajuste la fecha y la hora cuando use la videocámara por primera vez. De lo contrario, la pantalla [AJ. RELOJ] aparecerá cada vez que encienda la videocámara o cambie la posición del interruptor POWER.

- Si no usa la videocámara durante **aproximadamente 3 meses**, la batería recargable incorporada se descarga y es posible que los ajustes de la fecha y la hora se borren de la memoria. En este caso, cargue la batería recargable y ajuste la fecha y la hora nuevamente.

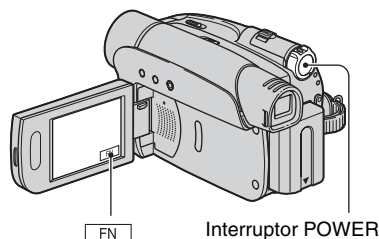

Salte al paso 4 cuando ajuste el reloj por primera vez.

## 1 Toque **[FN]** → **[MENU]**.

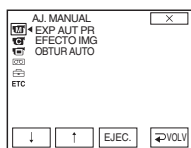

## 2 Seleccione **[AJ. RELOJ]** con **[↓]** / **[↑]**, luego toque **[EJEC.]**.

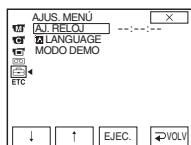

## 3 Seleccione **[AJ. RELOJ]** con **[↓]** / **[↑]**, luego toque **[EJEC.]**.

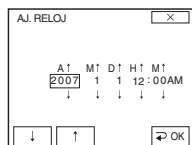

## 4 Ajuste **[A]** (año) con **[↓]** / **[↑]**, luego toque **[EJEC.]**.

Puede seleccionar cualquier año hasta el año 2079.

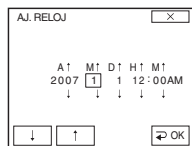

## 5 Ajuste **[M]** (mes) y toque **[EJEC.]** y, a continuación, repita el mismo proceso para **[D]** (día), **[H]** (hora) y **[M]** (minutos).

Ajuste la medianoche a las 12:00 AM.  
Ajuste el mediodía a las 12:00 PM.  
El reloj se pone en funcionamiento.

- Durante la grabación, no se visualizan la fecha y la hora, pero se graban automáticamente en la cinta y se pueden visualizar durante la reproducción ([CÓD. DATOS]) (Durante el funcionamiento de Easy Handycam, sólo se puede ajustar [FECHA/HORA]).

# Paso 7: Inserción de un videocasete

Solamente puede utilizar videocasetes mini DV <sup>Mini</sup> DV.

- El tiempo disponible para grabación varía en función del [MOD GRB].

- 1** Deslice y sostenga la palanca **OPEN/EJECT** en el sentido de la flecha y abra la tapa.

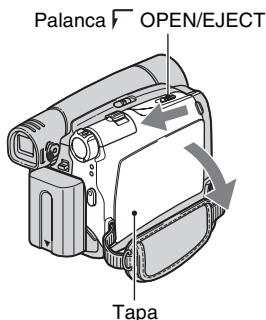

El compartimento del videocasete sale automáticamente y se abre.

- 2** Inserte un videocasete con la cara de la ventanilla hacia afuera y, a continuación, presione **PUSH**.

Presione ligeramente el centro de la parte posterior del videocasete.

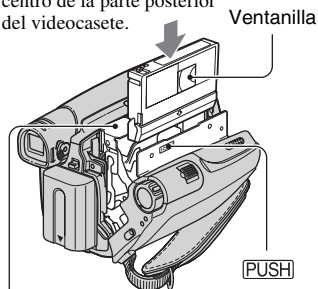

**El compartimento del videocasete se desliza automáticamente hacia adentro.**

- **No fuerce el compartimento del videocasete presionando la parte con la marca **DO NOT PUSH** mientras se desliza hacia adentro. Podría provocar una falla de funcionamiento.**

- 3** Cierre la tapa.

## Para expulsar el videocasete

Abra la tapa realizando el mismo procedimiento como se describe en el paso 1 y extraiga el videocasete.

# Grabación

## Tapa del objetivo

Extraer la tapa del objetivo presionando ambas palancas en los laterales de la tapa

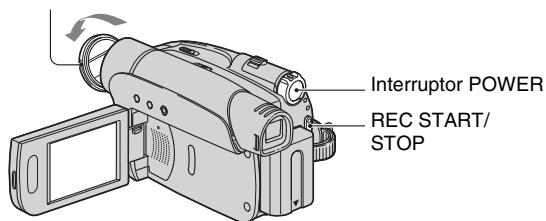

## 1 Deslice el interruptor POWER varias veces en el sentido de la flecha para que se encienda el indicador CAMERA.

Si el interruptor POWER está en la posición OFF(CHG), deslícelo mientras presiona el botón verde.

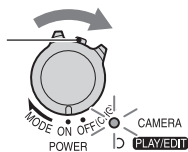

## 2 Presione REC START/STOP para iniciar la grabación.

El indicador (A) cambia [ESPERA] a [GRAB.].



## Para detener la grabación de la película

Presione REC START/STOP nuevamente.

# Reproducción

- 1 Deslice el indicador **POWER** en el sentido de la flecha varias veces para encender el indicador **PLAY/EDIT**.

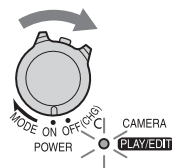

- 2 Inicie la reproducción.

Toque para rebobinar la cinta al punto deseado y luego presione para iniciar la reproducción.

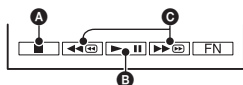

- A Detener
- B Reproducir/Pausa se alterna cada vez que toca el botón
  - La reproducción se detiene automáticamente si se acciona la pausa durante más de 3 min (minuto).
- C Rebobinar/Avanzar rápidamente

## Para ajustar el volumen

Toque → [PÁG.1] → [VOL], luego / para ajustar el volumen.

## Para buscar una escena durante la reproducción

Mantenga presionado / durante la reproducción (Búsqueda de imágenes), o / durante el avance rápido o rebobinado de la cinta (Exploración con salto).

- Puede reproducir en diversos modos ([REP VEL V]).









Additional information on this product and answers to frequently asked questions can be found at our Customer Support Website.

<http://www.sony.net/>



Printed on 70% or more recycled paper using VOC (Volatile Organic Compound)-free vegetable oil based ink.

Printed in Japan



2891370110