



Model No. DE45EM DE65EM

- Feature
- Two Fan Speeds
- Easy To Control
- Easy To Empty
- Easy Clean Air Filter
- Easy to move
- Automatic Humidistat Control
- Automatic Shut off/indicator Light

WARNING

This service information is designed for experienced repair technicians only and is not designed for use by the general public. It does not contain warnings or cautions to advise non-technical individuals of potential dangers in attempting to service a product. Products powered by electricity should be serviced or repaired only by experienced professional technicians. Any attempt to service or repair the product or products dealt with in this service information by anyone else could result in serious injury or death

Table of Contents

1. Product Code Illumination and Series introduction	1
2. Specifications.....	2
3. Safety and Precaution.....	3
4. Warning and Cautions.....	4
5. Features/Care&Cleaning	5
6. Parts and Functions.....	7
7. Abnormity Diagnose.....	8
8. System Flow Chart.....	10
9. Circuit Diagram.....	11
10.Wiring Diagram.....	13

1.Product Code Illumination and Series introduction

1). Model identification:

$\frac{D}{A}$ $\frac{E}{B}$ $\frac{\square\square}{C}$ $\frac{\square}{D}$ $\frac{\square}{E}$

A: Abbreviation of Dehumidifier

B: Remote Control

C: Nominal Dehumidifier Capacity (Pints/24hrs)

D: Energy Star

E: Design code

Examples

DE45EM

It represents remote control dehumidifier capacity is 45 pints/24hrs .

2). Standard situation/conditions

No.	Operating condition	Indoor air state		outdoor air state	
		D.B. °C	W.B. °C	D.B. °C	W.B. °C
1	Nominal dehumidifier	26.7	20.9	/	/

2.Specification

Item	DE45EM	DE65EM	
Capacity-Pints/24hrs	45	65	
Efficiency-Liter/kwh	1.85	1.85	
Airflow Rate(CFM)-High/Low	180/150	220/200	
Noise Level(db)-High/Low	57/56	57/56	
Bucket Capacity(Pints)	11	15	
Compressor Type	Rotary	Rotary	
Refrigerant Type/Charge amount(Oz)	R410A/7.4Oz	R410A/8.1Oz	
Voltage-Frequency(Hz)	115 - 60	115 - 60	
Running current(A)	4.2	6.2	
Power input(W)	480	690	
Plug Capacity(V/A)	125V/15A	125V/15A	
Plug Type/NEMA	A / 5-15P	A / 5-15P	
Power Cord Length	6'	6'	
Unit Dimensions (inches)	Height	21	23 1/2
	Width	13 3/8	15
	Depth	10 5/8	12
Packaging (inches)	Height	22 1/2	25 3/16
	Width	14 3/4	16 1/2
	Depth	12	14
Weight(lbs)	Net	16.8	17.7
	Gross	18.6	18.6
Container Loading(40'HQ)	910	740	

3. Safety and Precaution

PLEASE READ INSTRUCTIONS CAREFULLY BEFORE OPERATING DEHUMIDIFIER

Always take these basic precautions: This dehumidifier must be properly installed and grounded as described in this manual.

Never operate this dehumidifier in an area that is likely to accumulate standing water. If this situation develops, disconnect the power supply before touching, stepping into, or attempting to clean up the water.

Repair and replace immediately all electric service cords that have become frayed or otherwise damaged. DO NOT use a power cord that shows signs of damage anywhere along its length, at the plug, or where it is connected to the appliance.

Always unplug dehumidifier before servicing or moving the unit.

Caution

DO NOT cover the dehumidifier's air vents.

DO NOT allow children to climb on or play with the dehumidifier.

ALWAYS contact a professional for service and repair.

WARNING: You can be killed or seriously injured if you do not follow the instructions in this manual. Please keep these instructions for future reference.

4.Warning and Cautions

Grounding

This dehumidifier must be grounded to reduce the risk of electric shock by providing an escape wire for the electric current. This dehumidifier has a power cord with a grounding wire and a grounded 3-prong plug.

ONLY PLUG INTO AN OUTLET THAT IS PROPERLY INSTALLED AND GROUNDED.

Warning

Improper use of the grounding plug can result in the risk of an electric shock, injury, fire, or death. Call a qualified electrician if you do not understand the grounding instructions, or if you are not sure if the dehumidifier is properly grounded. If the wall outlet is not grounded, please contact a professional electrician to have it replaced with a properly grounded outlet.

Adapter Plug

Since most 2-prong outlets are not grounded, we strongly advise against using an adapter plug.

HOWEVER, a temporary connection may be made where local codes permit if the 2-prong wall outlet is properly grounded.

FOR SAFETY REASONS, make sure the larger prong of the adapter goes into the large slot.

FOR PROPER GROUNDING

Ground the adapter to the outlet by using the outlet cover screw to secure the ground terminal to the outlet box. Be absolutely certain that the outlet is grounded through the house wiring. **DO NOT USE** the dehumidifier until a proper ground has been made.

Extension Cord

If an extension cord is required to reach the nearest wall receptacle, use only a UL-listed, 3-wire, grounding type, 16 AWG, 15A, 125V appliance extension cord. **NO** other extension cord is permitted.

5.Features/Care&Cleaning

It is normal for the surrounding air to become slightly warmer as the dehumidifier operates. This warming effect further reduces the relative humidity of the surrounding air.

THERE ARE TWO WAYS TO REMOVE WATER FROM THE BUCKET:

1. Empty the bucket manually

When the water bucket is full, the red indicator light "BUCKET FULL" will go on.

1. YOU MUST turn the POWER off.
2. Wait a few minutes to allow the water to stop dripping.
3. Use both side handles to lift and remove the bucket.
4. Empty water through opening into a sink or tub.
5. Reinstall bucket.

IMPORTANT

Make sure the drain cap is tightened before operating the unit.

2. Attach a standard garden hose

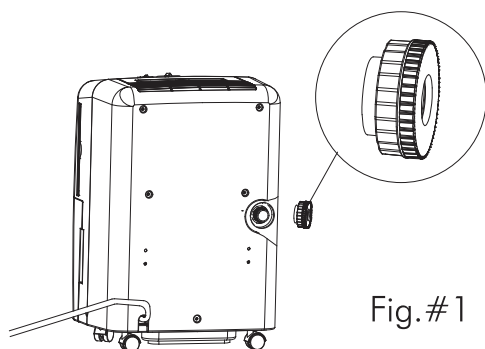

1.Remove the plastic cap at the rear of the unit.(Keep the rubber insert well for use later.)(Fig.#1)

2.Tightly screw the purchased garden hose to the direct drain opening.(Fig.#2)

3.Position the dehumidifier as close as you can to the floor drain.

4.Position the opening end of the drain hose directly over the floor drain and start the unit.

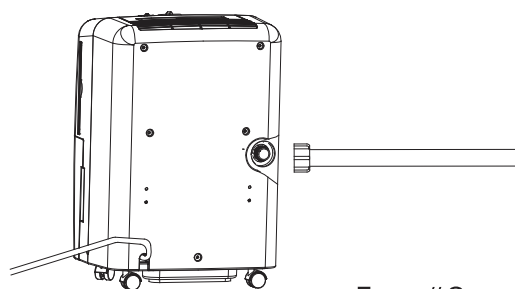

5.When the direct drain feature is not being used,remove the drain hose from the direct drain opening and plug it with the rubber cap provided.

Place the dehumidifier in a location that does not restrict airflow into the rear coil or out of the front grille.

The dehumidifier must be operated in an enclosed area to be most effective. Close all doors, windows and other outside openings to the room.

A dehumidifier operating in a basement will have little or no effect in drying an adjacent enclosed storage area, such as a closet, unless there is adequate circulation of air in and out of the area.

When the dehumidifier stops, wait at least 3 minutes before restarting.

PROPER CLEANING

Before cleaning, turn the dehumidifier off and remove the plug from the wall outlet. Use water and a mild detergent to clean the inlet and outlet grilles. DO NOT use bleach or abrasives.

The air filter is on the front of the dehumidifier. It should be checked at least every 2 to 3 weeks to see if it needs cleaning.

When the unit is turned on for the first time, the "Bucket Full" light may be lit. If you remove and replace the bucket, the light will shut off.

6.Parts and Functions

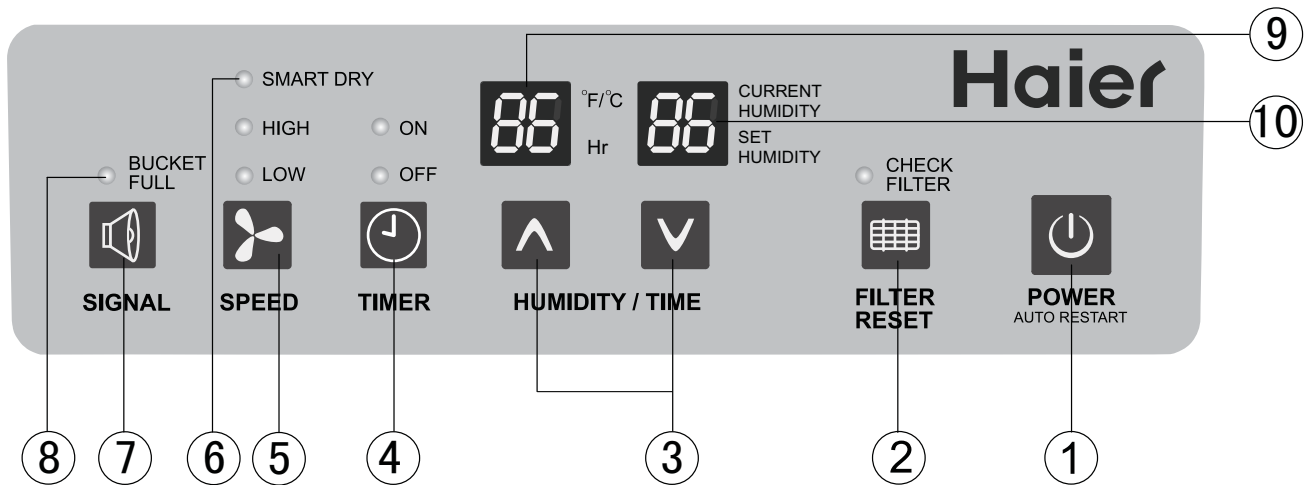

Features:

- 1** Power

Press POWER once to turn the dehumidifier ON and press POWER again to turn the dehumidifier OFF.
- 2** Check Filter Indicator

The "check filter" indicator will flash when the filter needs to be cleaned. Remove the filter, wash it, and put it back in. Press "Filter Reset." The "check filter" indicator will turn off.

Note: Make sure the filter is dry before replacing.
- 3** Humidistat

This allows you to adjust the humidity in the air. You can set the humidity to your desired level by pressing ▲ and ▼ keys.
- 4** Timer

Your dehumidifier can be set to turn on and off at pre-determined times. Pre-setting can be programmed up to 24 hours in advance.
- 5** Two Fan Speeds

This key controls the fan speed. There are two speed levels, LOW and HIGH.
- 6** Smart Dry

This setting compares the set humidity level with the actual humidity level and adjusts the fan speed automatically.
- 7** Signal

The bucket full audible signal can be turned on and off by pressing the SIGNAL button. The default setting is set in the ON position. When the bucket is full, the red BUCKET FULL indicator light will blink and the alarm will sound 5 times every 15 minutes.

To turn off the audible signal feature, press the SIGNAL button once, and the LED display will show "OF" for 2 seconds. In this setting, when the bucket is full, the BUCKET FULL indicator light will blink, but the audible alarm will not sound.

To reactivate the audible signal, press the SIGNAL button and the LED display to the left will show "ON" for 2 seconds.
- 8** Bucket Full Indicator

When the indicator light comes on, automatic flow control stops the unit.

Turn the unit off by pressing the POWER key. Check to see if the bucket is full. If so, empty it. If bucket is not full and indicator light is on, the bucket is not in the proper position. Remove and reinstall it.
- 9** Current Temp/Timer Set Display

When the dehumidifier is running, it displays the current temperature. Press the timer key to program the dehumidifier to turn on or off automatically at a pre-determined time.
- 10** Current Humidity/Setting Humidity Display

Displays the current humidity level and adjusts the humidity to a desired level.

Setting Humidity Range: 40%RH~70%RH
Display Humidity Range: (LO)30%RH~(HI)90%RH

7.Abnormity Diagnose

When ambient temperature sensor appear short trouble,E0 fault code will be displayed in the temperature indicator and the unit operating will stoped .When the coil temperature sensor appear short trouble,E1 fault code will be displayed in the temperature indicator and the unit will stoped .

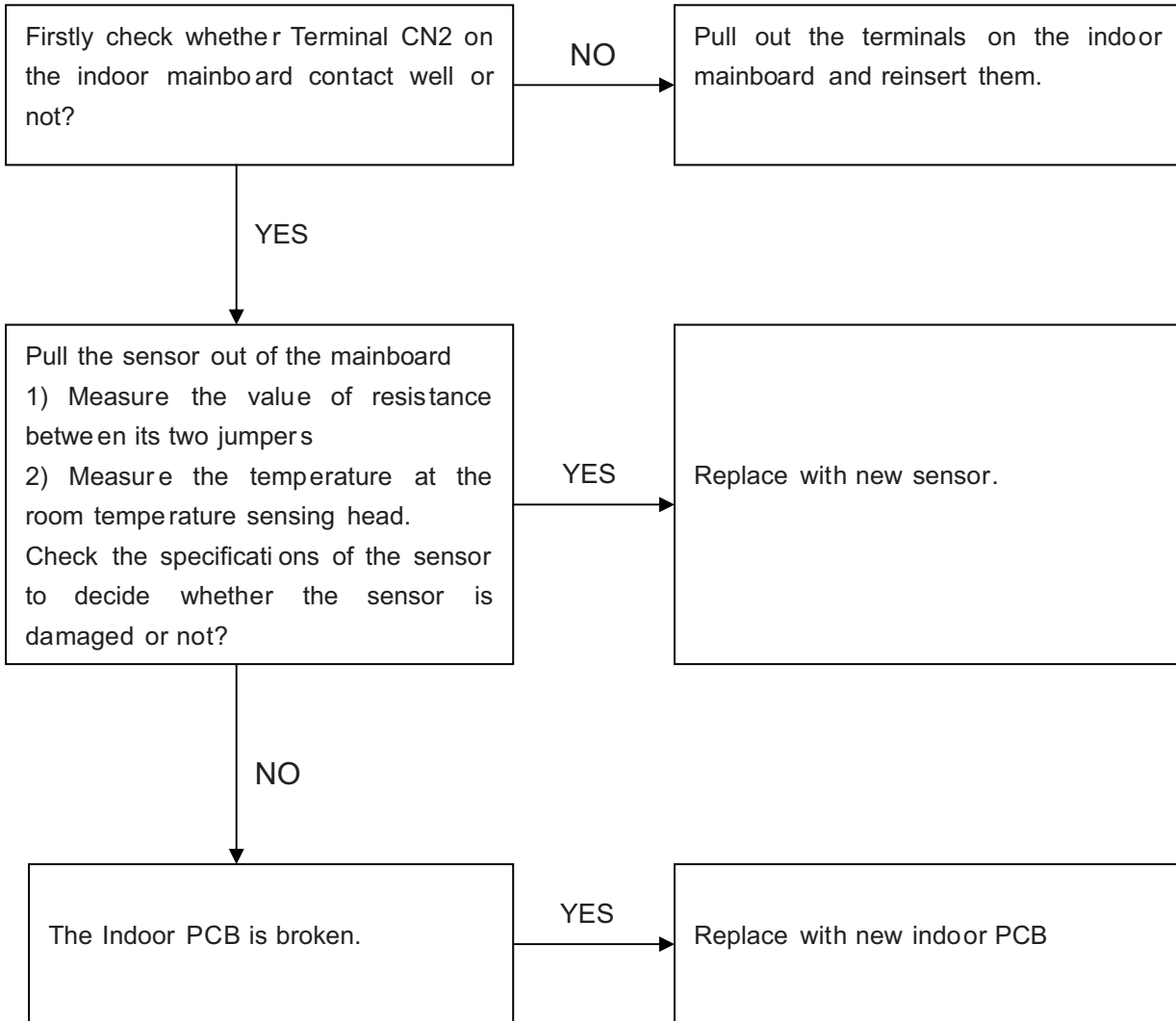

When the unit is ON,the key is failure(ofen ON or OFF),the E2 fault code will be displayed in the temperature indicator and the unit will be stoped .

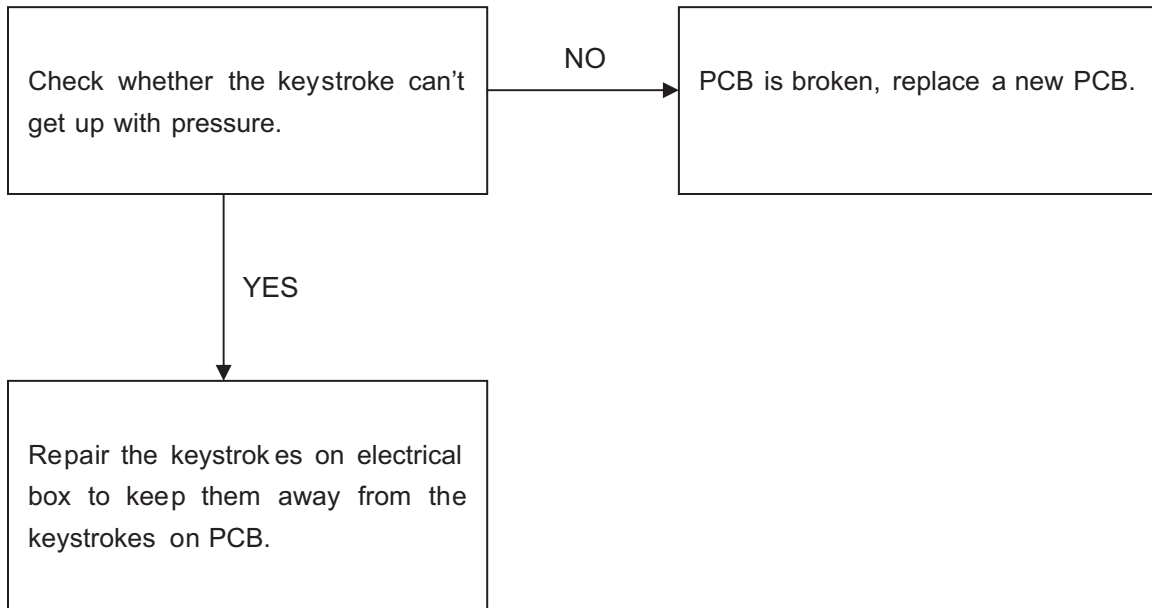

8.System Flow Chart

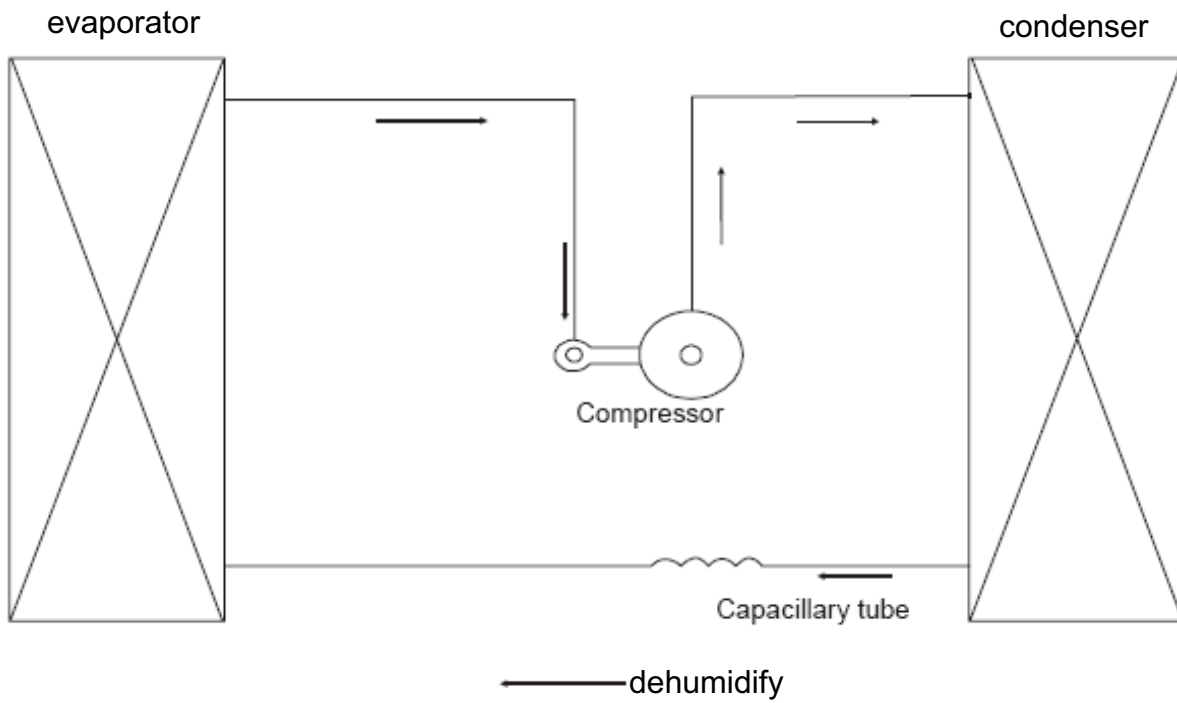

9.Circuit Diagram

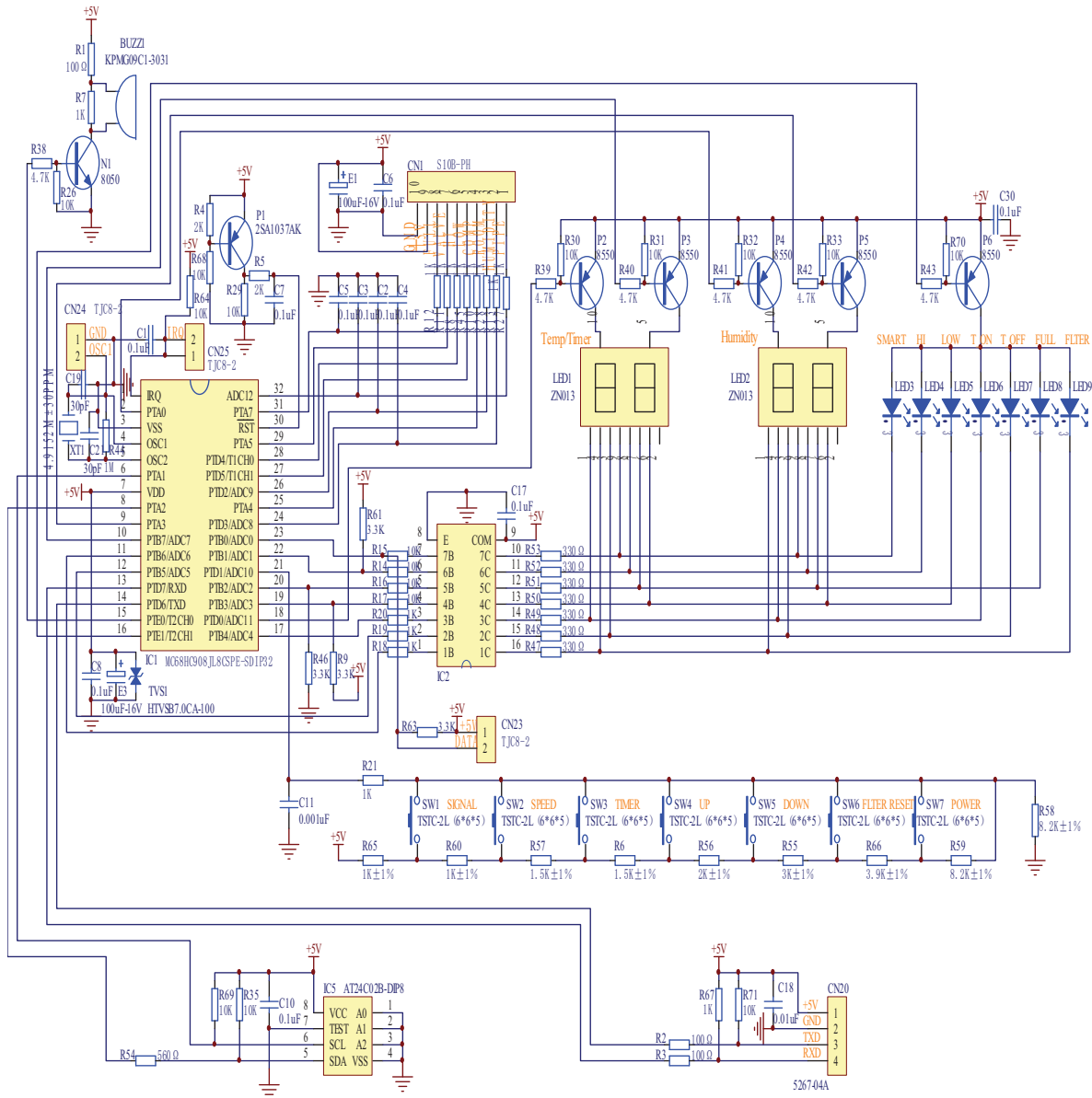

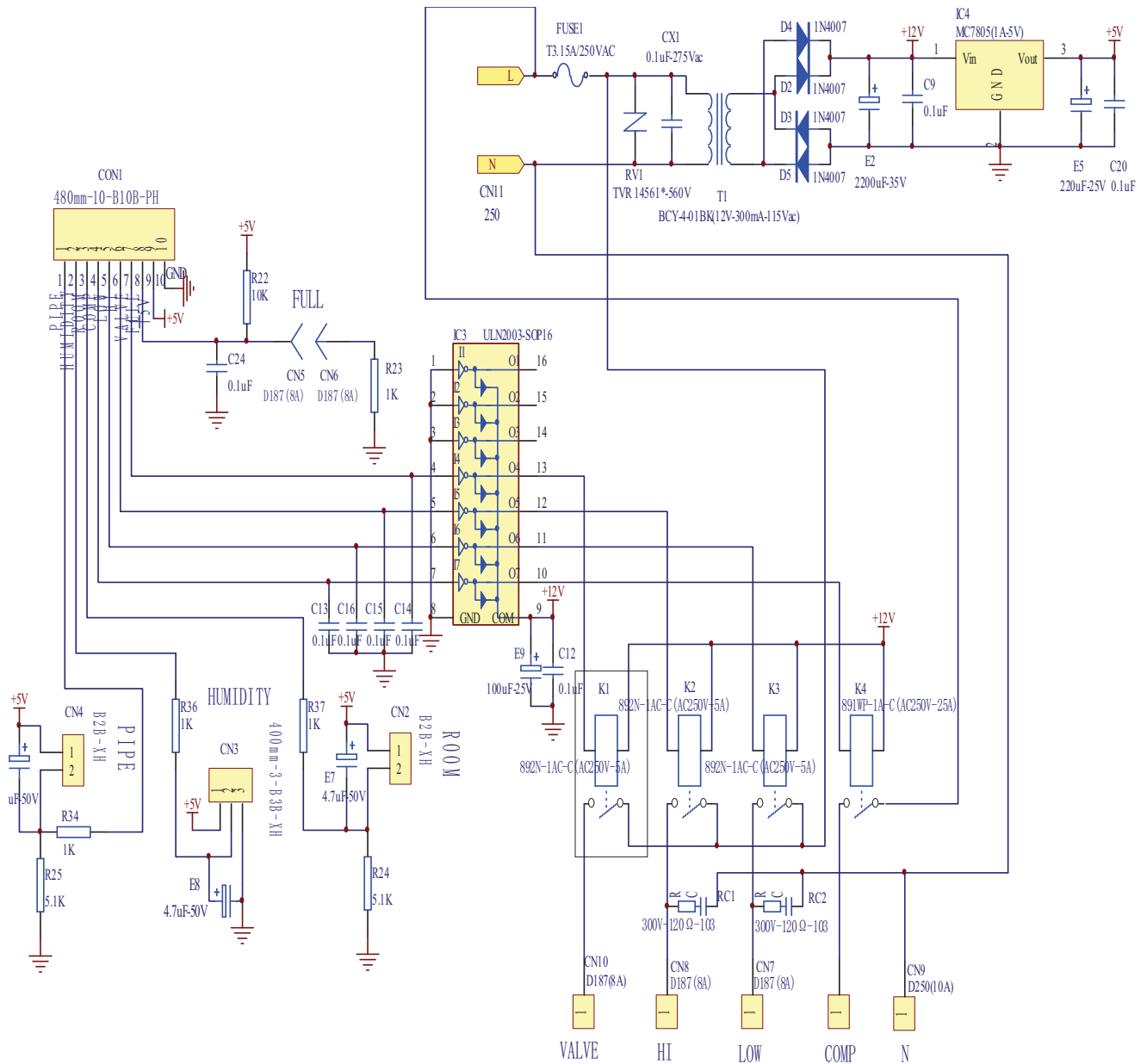

10.Wiring diagram

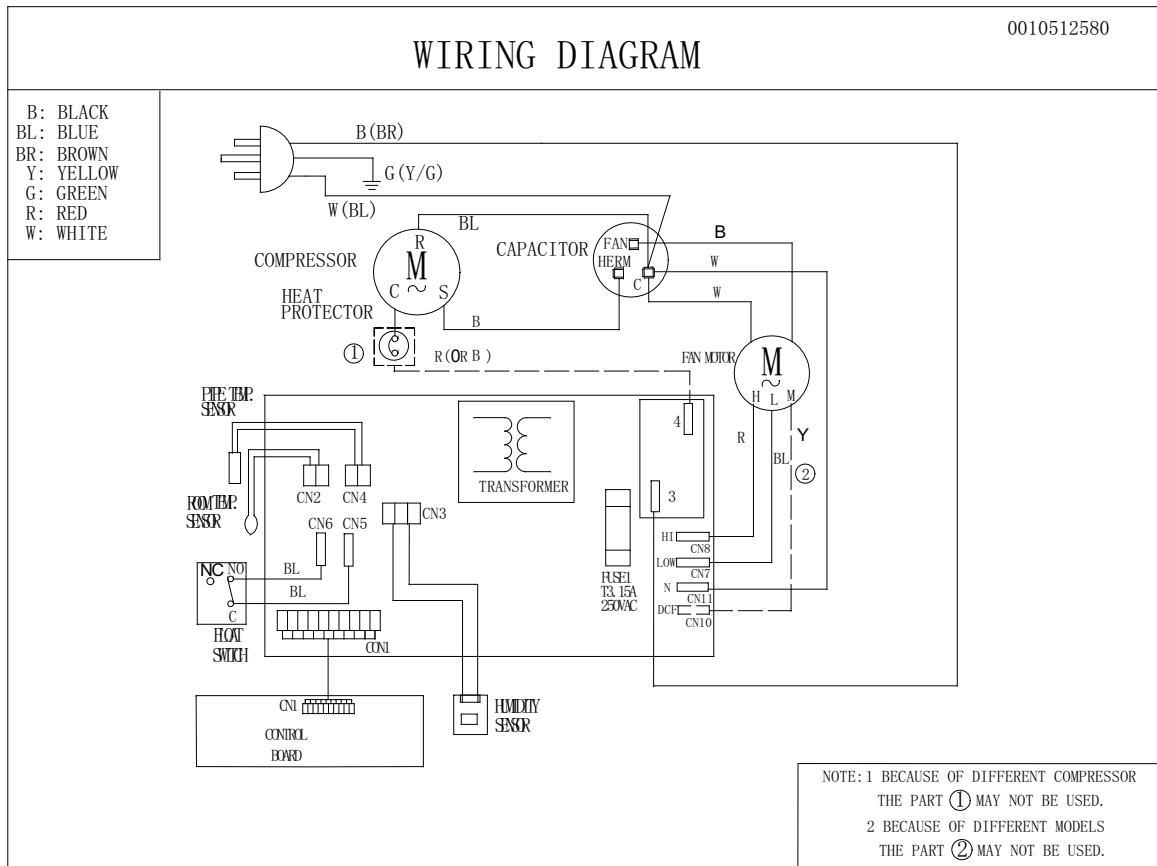

Sincere Forever

Haier Group

Haier Industrial Park, No.1, Haier Road

266101, Qingdao, China_

E-mail: hractech@haier.com

Tel: +86 532 88936935

[Http://www.haier.com](http://www.haier.com)

Factory Model NO. DE45EM/DE65EM

Some models may have an additional letter after the model number.

Edited by: GuanLi
DingCheng

Signed by: WangRuoFeng

Approved by: ZhangPeng