

Digital Video Camera Recorder ^{Mini DV} Digital Video Cassette

Operating Instructions

Before operating the unit, please read this manual thoroughly, and retain it for future reference.

Owner's Record

The model and serial numbers are located on the bottom. Record the serial number in the space provided below. Refer to these numbers whenever you call upon your Sony dealer regarding this product.

Model No. **DCR-TRV** _____ Model No. **AC**- _____

Serial No. _____ Serial No. _____

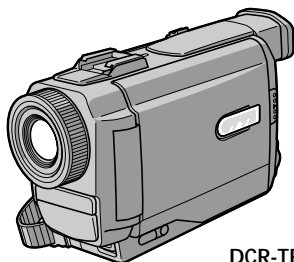

DCR-TRV10

Digital Handycam



DCR-TRV8/TRV10

Welcome!

Congratulations on your purchase of this Sony Digital Handycam camcorder. With your Digital Handycam, you can capture life's precious moments with superior picture and sound quality. Your Digital Handycam is loaded with advanced features, but at the same time it is very easy to use. You will soon be producing home video that you can enjoy for years to come.

WARNING

To prevent fire or shock hazard, do not expose the unit to rain or moisture.

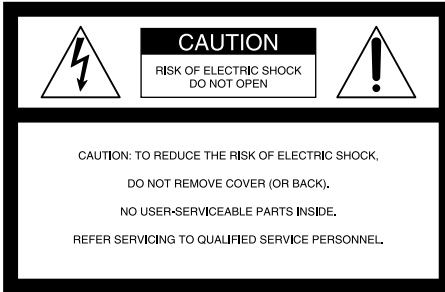

This symbol is intended to alert the user to the presence of uninsulated "dangerous voltage" within the product's enclosure that may be of sufficient magnitude to constitute a risk of electric shock to persons.



This symbol is intended to alert the user to the presence of important operating and maintenance (servicing) instructions in the literature accompanying the appliance.

Never expose the battery pack to temperatures above 140°F (60°C) such as in a car parked in the sun or under direct sunlight.

DISPOSAL OF LITHIUM ION BATTERY. LITHIUM ION BATTERY. DISPOSE OF PROPERLY.

You can return your unwanted lithium ion batteries to your nearest Sony Service Center or Factory Service Center.

Note: In some areas the disposal of lithium ion batteries in household or business trash may be prohibited.

For the Sony Service Center nearest you call 1-800-222-SONY (United States only)
For the Sony Factory Service Center nearest you call 416-499-SONY (Canada only)

Caution: Do not handle damaged or leaking lithium ion battery.

For customers in CANADA CAUTION

TO PREVENT ELECTRIC SHOCK, MATCH WIDE BLADE OF PLUG TO WIDE SLOT, FULLY INSERT.

For customers in the U.S.A. CAUTION

You are cautioned that any changes or modifications not expressly approved in this manual could void your authority to operate this equipment.

Declaration of Conformity

Trade Name: SONY
Model No.: DCR-TRV8, DCR-TRV10
Responsible Party: Sony Electronics Inc.
Address: 1 Sony Drive, Park Ridge, NJ, 07656 USA
Telephone No.: 201-930-6970

This device complies with Part 15 of the FCC Rules. Operation is subject to the following two conditions: (1) This device may not cause harmful interference, and (2) this device must accept any interference received, including interference that may cause undesired operation.

Note:

This equipment has been tested and found to comply with the limits for a Class B digital device, pursuant to Part 15 of the FCC Rules. These limits are designed to provide reasonable protection against harmful interference in a residential installation. This equipment generates, uses, and can radiate radio frequency energy and, if not installed and used in accordance with the instructions, may cause harmful interference to radio communications. However, there is no guarantee that interference will not occur in a particular installation. If this equipment does cause harmful interference to radio or television reception, which can be determined by turning the equipment off and on, the user is encouraged to try to correct the interference by one or more of the following measures:

- Reorient or relocate the receiving antenna.
- Increase the separation between the equipment and receiver.
- Connect the equipment into an outlet on a circuit different from that to which the receiver is connected.
- Consult the dealer or an experienced radio/TV technician for help.

Memory Stick

For customers in CANADA

This Class B digital apparatus complies with Canadian ICES-003.

For customers in the U.S.A.

This device complies with Part 15 of the FCC Rules. Operation is subject to the following two conditions: (1) This device may not cause harmful interference, and (2) this device must accept any interference received, including interference that may cause undesired operation.

Table of contents

Quick Start Guide	4	Making your own titles	68
Labeling a cassette		70	
Getting started		Customizing Your Camcorder	
Using this manual	6	Changing the MENU settings	72
Checking supplied accessories	8	Resetting the date and time	78
Step 1 Preparing the power supply	9		
Installing the battery pack	9	Memory Stick operations	
Charging the battery pack	10	(DCR-TRV10 only)	
Connecting to a wall outlet	13	Using a Memory Stick—introduction ..	79
Step 2 Inserting a cassette	14	Recording still images on Memory Sticks	
		– Memory photo recording	85
Recording – Basics		Recording an image from a mini DV	
Recording a picture	15	tape as a still image	89
Shooting backlit subjects (BACK LIGHT) ...	21	Copying still images from a mini DV	
Shooting in the dark (NightShot)	21	tape – Photo save	91
Checking the recording – END SEARCH		Viewing a still picture – Memory photo	
/ EDITSEARCH / Rec Review	24	playback	93
		Superimposing a still picture in a Memory Stick	
Playback – Basics		on a moving picture – M. CHROM/ M. LUMI/C. CHROM.....	97
Playing back a tape	25	Preventing accidental erasure	
Viewing the recording on TV	28	– Image protection	100
		Writing a print mark – PRINT MARK ...	101
Advanced Recording Operations		Deleting images	102
Photo recording	30	Copying the image recorded on Memory	
Using the wide mode	32	Sticks to mini DV tapes	105
Using the fader function	33	Playing back images in a continuous	
Using special effects – Picture effect ..	36	loop – SLIDE SHOW	107
Using special effects – Digital effect ...	38		
Adjusting the white balance manually ...	41	Additional Information	
Using the PROGRAM AE function	42	Usable cassettes	109
Adjusting the exposure manually	44	Troubleshooting	111
Focusing manually	45	Self-diagnosis display	116
		Warning indicators and messages	117
Advanced Playback Operations		Using your camcorder abroad	119
Playing back a tape with picture effects ...	46	Maintenance information and	
Playing back a tape with digital effects ...	47	precautions	120
Quickly locating a scene using the zero		Specifications	124
set memory function	48		
Searching a recording by date – Date search ..	49	Quick Reference	
Searching the boundaries of recorded		Identifying the parts and controls	125
tape by title – Title search	51	Quick Function Guide	135
Searching for a photo – Photo search/ Photo scan	52	Index	Back cover
Editing			
Dubbing a tape	54		
Editing partially on a DV tape – DV			
synchro-editing (DCR-TRV10 only) ..	56		
Recording video or TV programs	58		
Inserting a scene from a VCR	59		
Audio dubbing	61		
Superimposing a title	65		

- Windows is registered trademarks licensed to Microsoft Corporation, registered in the U.S.A. and other countries.
- All other product names mentioned herein may be the trademarks or registered trademarks of their respective companies.

Furthermore, “™” and “®” are not mentioned in each case in this manual.

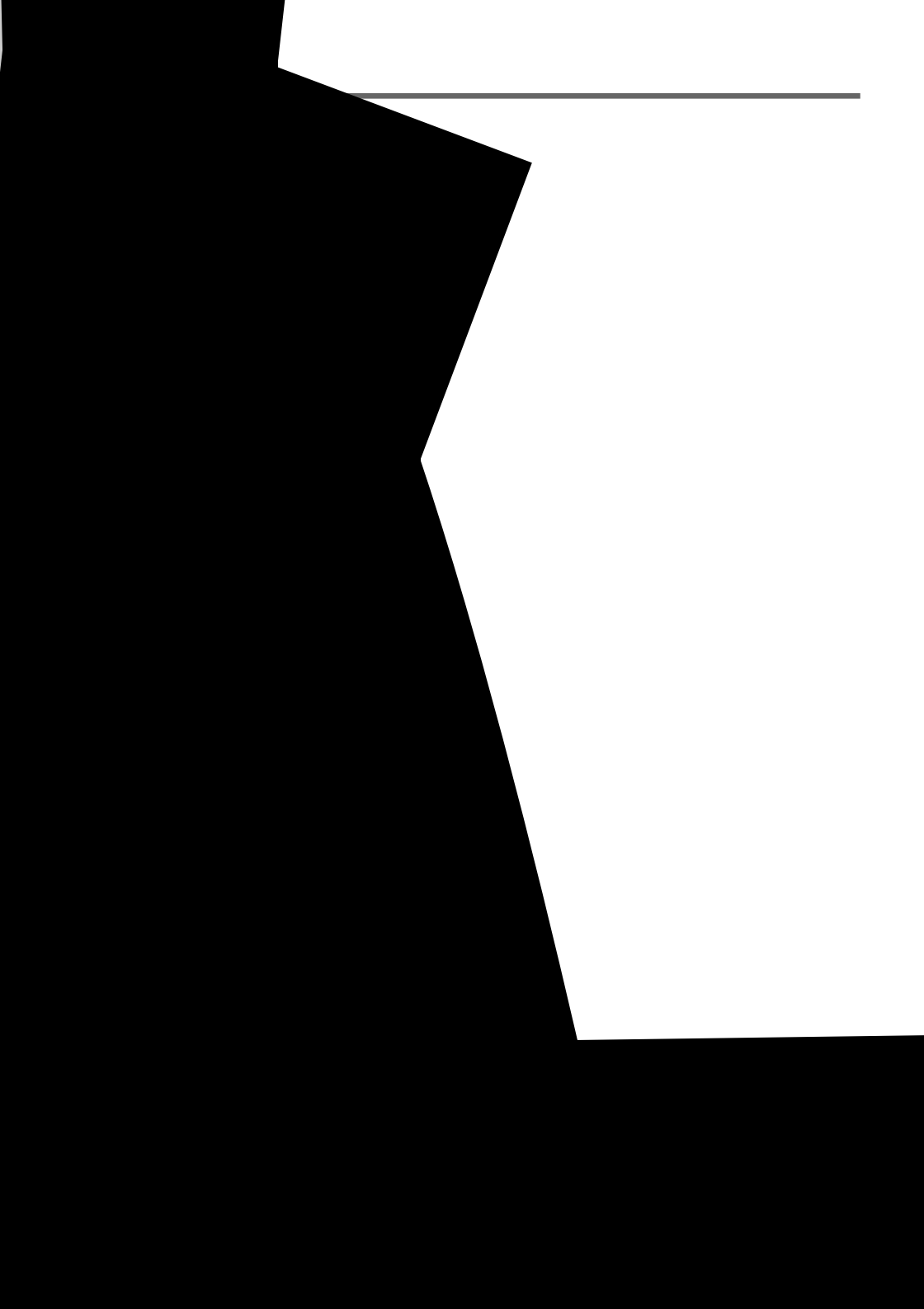



Using this manual

The instructions in this manual are for the two models listed in the table below. Before you start reading this manual and operating your camcorder, check the model number by looking at the bottom of your camcorder. The DCR-TRV10 is the model used for illustration purposes. Otherwise, the model name is indicated in the illustrations. Any differences in operation are clearly indicated in the text, for example, “DCR-TRV10 only.”

As you read through this manual, buttons and settings on your camcorder are shown in capital letters.

e.g. Set the POWER switch to CAMERA.

When you carry out an operation, you can hear a beep sound to indicate that the operation is being carried out.

Types of differences

DCR-	TRV8	TRV10
DV synchro-editing	—	●
MEMORY mark* (on the POWER switch)	—	●

● Provided

— Not provided

* The model with MEMORY marked on the POWER switch is provided with memory functions. See page 79 for details.

Note on Cassette Memory

Your camcorder is based on the DV format. You can only use mini DV cassettes with your camcorder. We recommend you to use a tape with cassette memory **CM**.

The functions which depend on whether the tape has the cassette memory or not are:

- End search (p. 24, 27)
- Searching a recording by date – date search (p. 49)
- Photo search (p. 52).

The functions you can operate only with the cassette memory are:

- Searching the boundaries of recorded tape by title – title search (p. 51)
- Superimposing a title (p. 65)
- Making your own titles (p. 68)
- Labeling a cassette (p. 70).

For details, see page 109.

CM only You see this mark in the introduction of the features that operate only with cassette memory.

Tapes with cassette memory are marked by **CM** (Cassette Memory).

Note on TV color systems

TV color systems differ from country to country. To view your recordings on a TV, you need an NTSC system-based TV.

Copyright precautions

Television programs, films, video tapes, and other materials may be copyrighted. Unauthorized recording of such materials may be contrary to the provision of the copyright laws.

Precautions on camcorder care

- The LCD screen and/or the color viewfinder are manufactured using high-precision technology. However, there may be some tiny black spots and/or bright spots (red, blue or green in color) that constantly appear on the LCD screen and/or in the color viewfinder. These spots occur normally in the manufacturing process and do not affect the recorded picture in any way. Effective number of pixels is 99.99% or more.
- Do not let your camcorder get wet. Keep your camcorder away from rain and sea water. Letting your camcorder get wet may cause your camcorder to malfunction. Sometimes this malfunction cannot be repaired [a].
- Never leave your camcorder exposed to temperatures above 140°F (60°C), such as in a car parked in the sun or under direct sunlight [b].
- Do not place your camcorder so as to point the viewfinder or the LCD screen toward the sun. The inside of the viewfinder or LCD screen may be damaged [c].

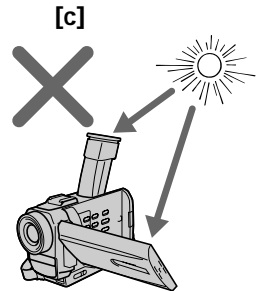
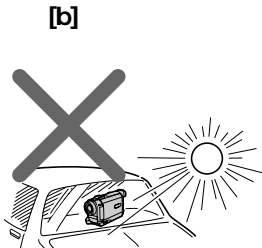
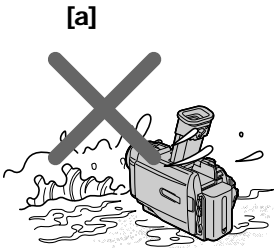

Contents of the recording cannot be compensated if recording or playback is not made due to a malfunction of the camcorder, video tape, etc.

Checking supplied accessories

Make sure that the following accessories are supplied with your camcorder.

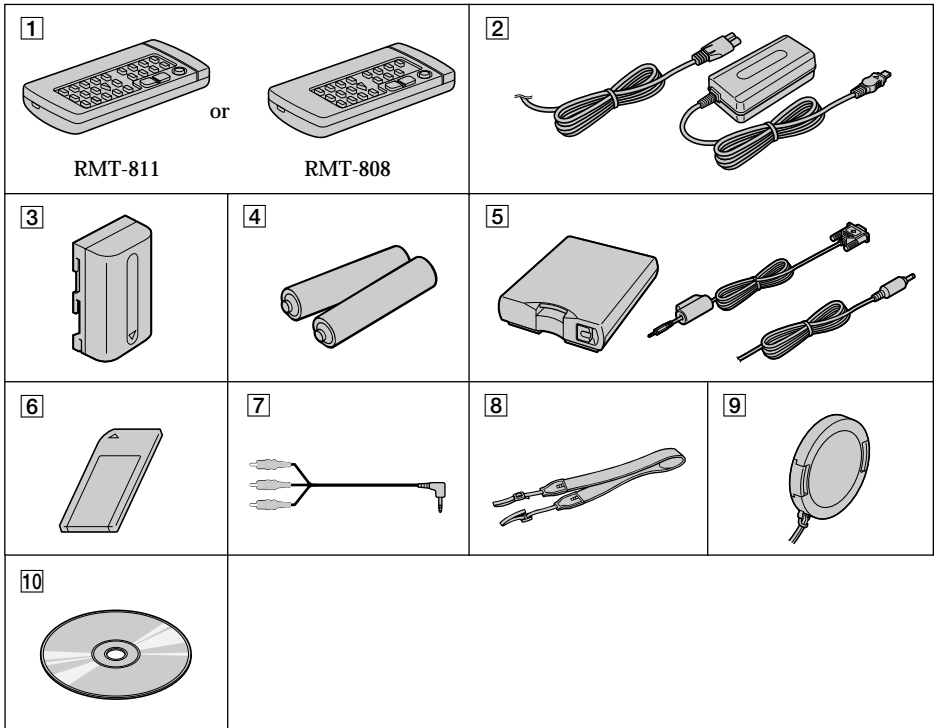

1 Wireless Remote Commander (1)
(p. 132)
RMT-811: DCR-TRV10
RMT-808: DCR-TRV8

2 AC-L10A/L10B/L10C AC power adaptor
(1), Power cord (1) (p. 10)

3 NP-FM50 battery pack (1) (p. 9, 10)

4 Size AA (R6) battery for Remote
Commander (2) (p. 132).

5 Serial port adaptor for Memory Stick
(1), PC serial cable (1), AC power
adaptor for Serial port adaptor (1)
(p. 96)
DCR-TRV10 only

6 Memory Stick (1) (p. 79)
DCR-TRV10 only

7 A/V connecting cable (1) (p. 28, 54)

8 Shoulder strap (1) (p. 129)

9 Lens cap (1) (p. 15)

10 Application software: PictureGear
3.2Lite (CD ROM) (1) (p. 96)
DCR-TRV10 only

Step 1 Preparing the power supply

Installing the battery pack

Install the battery pack to use your camcorder outdoors.

- (1) Lift up the viewfinder.
- (2) Slide the battery pack down until it clicks.

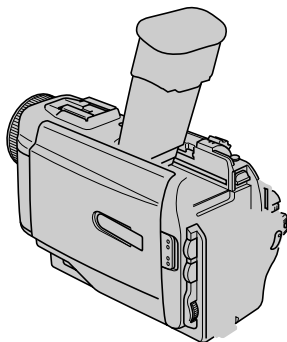

To remove the battery pack

Lift up the viewfinder.

Slide the battery pack out in the direction of the arrow while pressing BATT down.

After installing the battery pack

Do not carry your camcorder by holding the battery pack. If you do so, the battery pack may slide off your camcorder unintentionally, damaging your camcorder.

If you use the large capacity battery pack

If you install the NP-FM70/FM90 battery pack on your camcorder, extend its viewfinder. Take care not to pinch your finger when lifting the viewfinder up and down.

Step 1 Preparing the power supply

Charging the battery pack

Use the battery pack after charging it for your camcorder.

Your camcorder operates only with the “InfoLITHIUM” battery pack (M series).

“InfoLITHIUM” is a trademark of Sony Corporation.

- (1) Open the DC IN jack cover and connect the AC power adaptor supplied with your camcorder to the DC IN jack with the plug's ▲ mark facing up.
- (2) Connect the power cord to the AC power adaptor.
- (3) Connect the power cord to a wall outlet.
- (4) Set the POWER switch to OFF. Charging begins. The remaining battery time is indicated in minutes on the display window.

When the remaining battery indicator changes to , **normal charge** is completed. To fully charge the battery (**full charge**), leave the battery pack attached for about 1 hour after normal charge is completed until **FULL** appears in the display window. Fully charging the battery allows you to use the battery longer than usual.

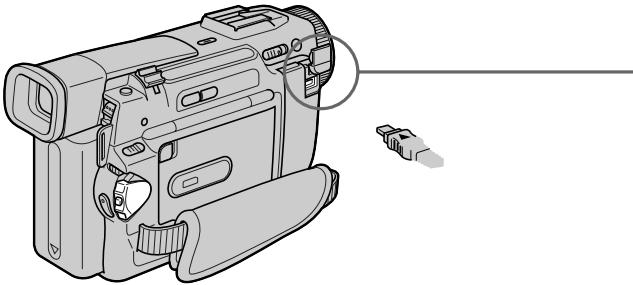

Step 1 Preparing the power supply

Note

Prevent metallic objects from coming into contact with the metal parts of the DC plug of the AC power adaptor. This may cause a short-circuit, damaging the AC power adaptor.

Remaining battery time indicator

The remaining battery time indicator in the display window roughly indicates the recording time.

Until your camcorder calculates the actual remaining battery time

“--- min” appears in the display window.

While charging the battery pack, no indicator appears or the indicator flashes in the display window in the following cases

- The battery pack is not installed correctly.
- The AC power adaptor is disconnected.
- Something is wrong with the battery pack.

Charging time

Battery pack	Full charge (Normal charge)
NP-FM50 (supplied)	150 (90)
NP-FM70	240 (180)
NP-FM90	330 (270)

Approximate number of minutes to charge an empty battery pack

Recording time

DCR-TRV8

Battery pack	Recording with the viewfinder		Recording with the LCD screen	
	Continuous*	Typical**	Continuous*	Typical**
NP-FM50 (supplied)	170 (155)	90 (80)	135 (120)	70 (60)
NP-FM70	355 (320)	190 (170)	285 (255)	150 (135)
NP-FM90	540 (485)	290 (260)	435 (390)	230 (210)

DCR-TRV10

Battery pack	Recording with the viewfinder		Recording with the LCD screen	
	Continuous*	Typical**	Continuous*	Typical**
NP-FM50 (supplied)	170 (155)	90 (80)	130 (115)	70 (60)
NP-FM70	355 (320)	190 (170)	270 (245)	145 (130)
NP-FM90	540 (485)	290 (260)	410 (370)	220 (195)

Approximate number of minutes when you use a fully charged battery

Numbers in parentheses “()” indicate the time using a normally charged battery.

* Approximate continuous recording time at 77°F (25°C). The battery life will be shorter if you use your camcorder in a cold environment.

** Approximate number of minutes when recording while you repeat recording start/stop, zooming and turning the power on/off. The actual battery life may be shorter.

Step 1 Preparing the power supply

Playing time

DCR-TRV8

Battery pack	Playing time on LCD screen	Playing time with LCD closed
NP-FM50 (supplied)	140 (125)	180 (160)
NP-FM70	295 (265)	370 (330)
NP-FM90	450 (400)	560 (505)

DCR-TRV10

Battery pack	Playing time on LCD screen	Playing time with LCD closed
NP-FM50 (supplied)	135 (120)	180 (160)
NP-FM70	275 (250)	370 (330)
NP-FM90	425 (380)	560 (505)

Approximate number of minutes when you use a fully charged battery

Numbers in parentheses “ () ” indicate the time using a normally charged battery. The battery life will be shorter if you use your camcorder in a cold environment.

After charging the battery pack

Disconnect the AC power adaptor from the DC IN jack on your camcorder.

Note on the remaining battery time indicator during recording

The indicator may not be correct, depending on the conditions in which you are recording. When you close the LCD panel and open it again, it takes about 1 minute for the correct remaining battery time to be displayed.

What is “InfoLITHIUM”?

The “InfoLITHIUM” is a lithium ion battery pack which can exchange data such as battery consumption with compatible video equipment. This unit is compatible with the “InfoLITHIUM” battery pack (M series). Your camcorder operates only with the “InfoLITHIUM” battery. “InfoLITHIUM” M series battery packs have the  mark.

“InfoLITHIUM” is a trademark of Sony Corporation.

Step 1 Preparing the power supply

Connecting to a wall outlet

When you use your camcorder for a long time, we recommend that you power it from a wall outlet using the AC power adaptor.

- (1) Open the DC IN jack cover, pulling the cover out a little and rotating it.
Connect the AC power adaptor to the DC IN jack on your camcorder with the plug's ▲ mark facing up.
- (2) Connect the power cord to the AC power adaptor.
- (3) Connect the power cord to a wall outlet.

Getting started

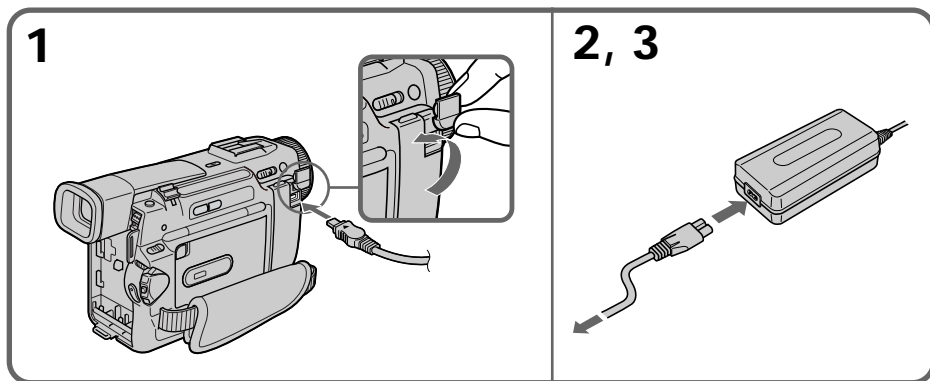

WARNING

The power cord must only be changed at a qualified service shop.

PRECAUTION

The set is not disconnected from the AC power source (house current) as long as it is connected to the wall outlet, even if the set itself has been turned off.

Notes

- The AC power adaptor can supply power even if the battery pack is attached to your camcorder.
- The DC IN jack has “source priority”. This means that the battery pack cannot supply any power if the power cord is connected to the DC IN jack, even when the power cord is not plugged into a wall outlet.
- Keep the AC power adaptor away from your camcorder if the picture is disturbed.

Using a car battery

Use Sony DC Adaptor/Charger (not supplied).

Step 2 Inserting a cassette

- (1) Slide **▲ OPEN/EJECT** in the direction of the arrow and open the lid. The cassette compartment automatically lifts up and opens.
- (2) Push the middle portion of the back of the cassette to insert. Insert the cassette in a straight line deeply into the cassette compartment with the window facing out.
- (3) Close the cassette compartment by pressing the **PUSH** mark on the cassette compartment. The cassette compartment automatically goes down.
- (4) After the cassette compartment going down completely, close the lid until it clicks.

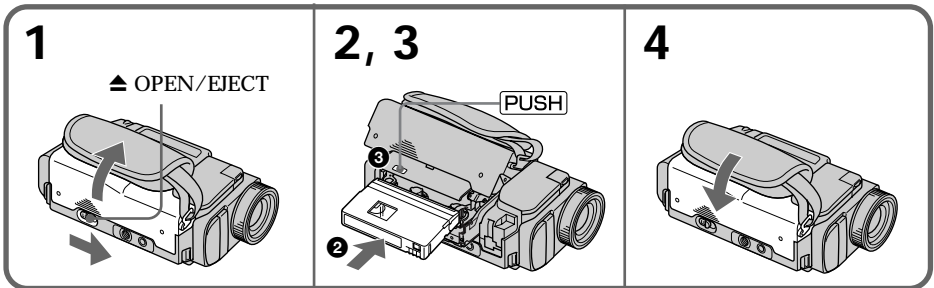

To eject a cassette

Follow the procedure above and in step 2, take out the cassette.

Notes

- Do not press the cassette compartment down. Doing so may cause malfunction.
- The cassette compartment may not be closed when you press any part of the lid other than the **PUSH** mark.

When you use mini DV cassette with cassette memory

Read the instruction about cassette memory to use this function properly (p. 109).

To prevent misoperation of your camcorder

Set the **POWER** switch to **OFF** when you insert and eject a cassette.

To prevent accidental erasure

Slide the write-protect tab on the cassette to expose the red mark.

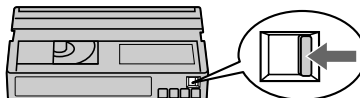

Recording a picture

Your camcorder automatically focuses for you.

- (1) Remove the lens cap by pressing both knobs on its sides and attach the lens cap to the grip strap.
- (2) Install the power source and insert a cassette. See “Step 1” and “Step 2” for more information (p. 9 to p. 14).
- (3) Set the POWER switch to CAMERA while pressing the small green button. Your camcorder is set to the standby mode.
- (4) Slide OPEN in the direction of the ►mark. Then, open the LCD panel. The viewfinder automatically turns off.
- (5) Press START/STOP. Your camcorder starts recording. The “REC” indicator appears. The camera recording lamp located on the front of your camcorder lights up. To stop recording, press START/STOP again.

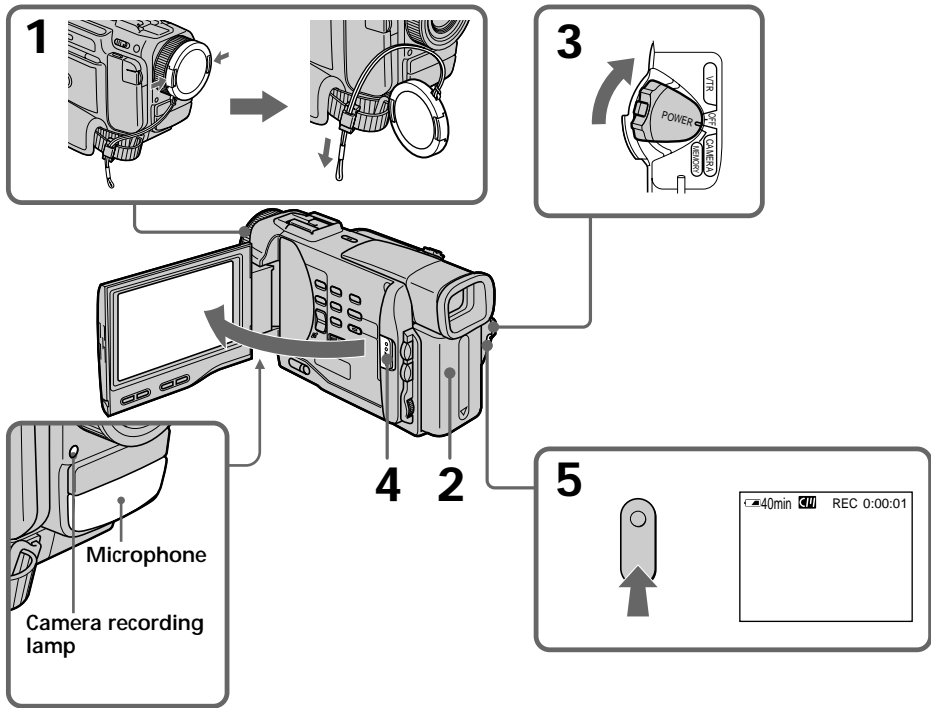

Recording a picture

Note

Fasten the grip strap firmly. Do not touch the built-in microphone during recording.

Note on Recording mode

Your camcorder records and plays back in the SP (standard play) mode and in the LP (long play) mode. Select SP or LP in the MENU settings. In the LP mode, you can record 1.5 times as long as in the SP mode.

When you record a tape in the LP mode on your camcorder, we recommend playing the tape on your camcorder.

Note on the lock (DCR-TRV10 only)

When you slide the lock to the right, the POWER switch can no longer be set to MEMORY accidentally. The lock is set to the left before your camcorder leaves the factory.

To enable smooth transition

Transition between the last scene you recorded and the next scene is smooth as long as you do not eject the cassette even if you turn off your camcorder. When you change the battery pack, set the POWER switch to OFF. When you use a tape with cassette memory, however, you can make the transition smooth even after ejecting the cassette if you use the END SEARCH function (p. 24).

If you leave your camcorder in the standby mode for 5 minutes while the cassette is inserted

Your camcorder automatically turns off. This is to save battery power and to prevent battery and tape wear. To resume the standby mode, set the POWER switch to OFF, and to CAMERA again.

When you record in the SP and LP modes on one tape or you record some scenes in the LP mode

The playback picture may be distorted or the time code may not be written properly between scenes.

Recording a picture

To record pictures with the viewfinder – adjusting the viewfinder

If you record pictures with the LCD panel closed, check the picture with the viewfinder. Adjust the viewfinder lens to your eyesight so that the indicators in the viewfinder come into sharp focus.

Lift up the viewfinder and move the viewfinder lens adjustment lever.

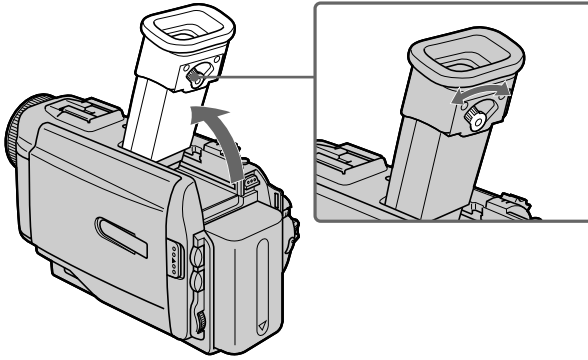

Recording a picture

Using the zoom feature

Move the power zoom lever a little for a slower zoom. Move it further for a faster zoom. Using the zoom function sparingly results in better-looking recordings.

“T” side: for telephoto (subject appears closer)

“W” side: for wide-angle (subject appears farther away)

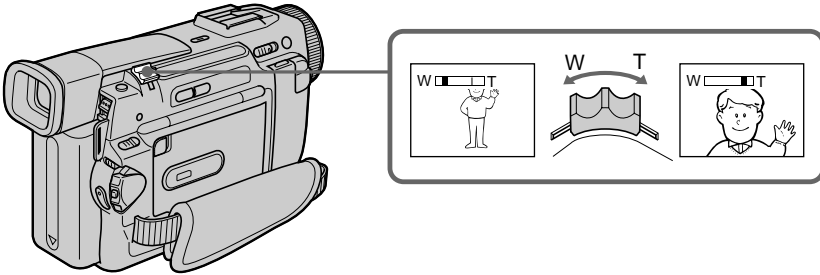

Zoom greater than 10× is performed digitally, if you set D ZOOM to ON in the MENU settings. The digital zoom function is set to OFF at the factory. (p. 72)

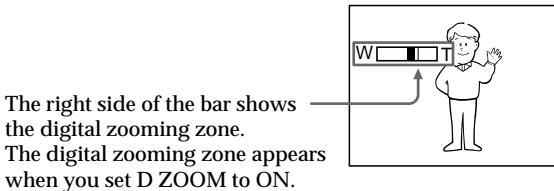

The right side of the bar shows the digital zooming zone. The digital zooming zone appears when you set D ZOOM to ON.

When you shoot close to a subject

If you cannot get a sharp focus, move the power zoom lever to the “W” side until the focus is sharp. You can shoot a subject that is at least about 2 feet 5/8 inch (about 80 cm) away from the lens surface in the telephoto position, or about 1/2 inch (about 1 cm) away in the wide-angle position.

Notes on digital zoom

- Digital zoom starts to function when zoom exceeds 10×.
- The picture quality deteriorates as you go toward the “T” side. Set D ZOOM to OFF in the MENU settings. Otherwise the digital zoom activates without notice (p. 72).

Recording a picture

START/STOP MODE setting

: Recording starts when you press START/STOP, and stops when you press it again (factory setting).

ANTI GROUND SHOOTING :

Your camcorder records only while you press START/STOP. Use this mode to avoid recording unnecessary scenes.

5SEC: When you press use this mode to START/STOP, your camcorder records for 5 seconds and then stops automatically.

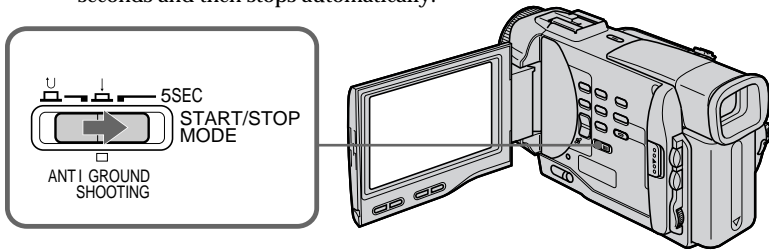

Notes

- You cannot use the fader function in the 5SEC or  mode.
- The time code does not appear in the 5SEC mode.

To extend the recording time in the 5SEC mode

Five dots (●●●●●) appear, and then disappear at a rate of one per second. To extend the recording time, press START/STOP again before all the dots disappear. Recording continues for about 5 seconds from the moment you press START/STOP.

Indicators displayed in the recording mode

The indicators are not recorded on tape.

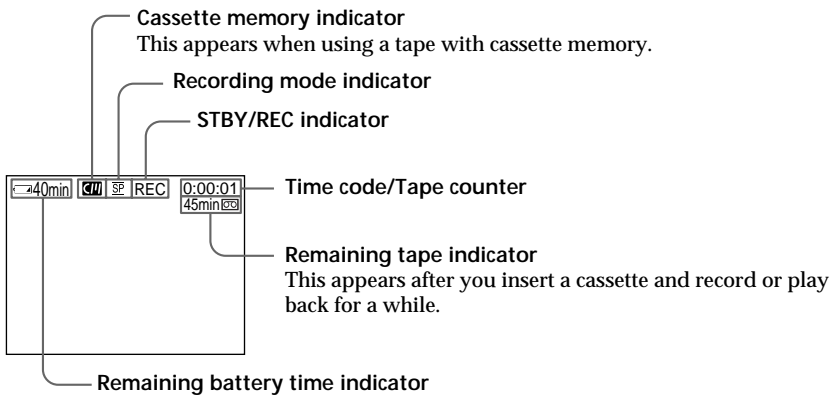

Time code

The time code indicates the recording or playback time, "0:00:00" (hours : minutes : seconds) in CAMERA mode and "0:00:00:00" (hours : minutes : seconds : frames) in VTR mode. You cannot rewrite only the time code.

Your camcorder uses the drop frame mode.

Remaining tape indicator

The indicator may not be displayed accurately depending on the tape.

Recording a picture

Shooting backlit subjects (BACK LIGHT)

When you shoot a subject with the light source behind the subject or a subject with a light background, use the backlight function.

Press BACK LIGHT in the recording or standby mode.

The  indicator appears in the viewfinder or on the LCD screen.

To cancel, press BACK LIGHT again.

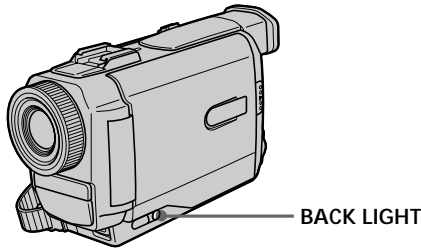

If you press EXPOSURE when shooting backlit subjects

The backlight function will be canceled.

Shooting in the dark (NightShot)

The NightShot function enables you to shoot a subject in a dark place. For example, you can satisfactorily record the environment of nocturnal animals for observation when you use this function.

- (1) While your camcorder is in the standby mode, slide NIGHTSHOT to ON.
- (2) Press START/STOP to start recording.



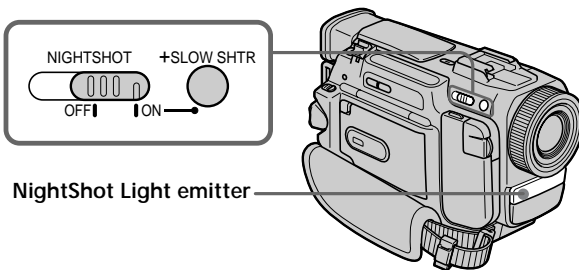

 and "NIGHTSHOT" indicators flash on the LCD screen or in the viewfinder. To cancel the NightShot function, slide NIGHTSHOT to OFF.



Recording a picture

Using +SLOW SHTR

The NightShot +Slow shutter mode makes subjects more than four times brighter than those recorded in the NightShot mode.

- (1) Slide NIGHTSHOT to ON in the standby or recording mode.  indicator appears.
- (2) Press +SLOW SHTR until the desired NIGHTSHOT indicator flashes.
The indicator changes as follows:
 (NIGHTSHOT) →  (NIGHTSHOT1) →  (NIGHTSHOT2) →  (NIGHTSHOT)
To cancel the NightShot +Slow shutter mode, slide NIGHTSHOT to OFF.

Using the NightShot Light

The picture will be clearer with the NightShot Light on. To enable NightShot Light, set N.S.LIGHT to ON in the MENU settings (p. 72).

Notes



- Do not use the NightShot function in bright places (ex. outdoors in the daytime). This may cause your camcorder to malfunction.
- When you keep NIGHTSHOT set to ON in normal recording, the picture may be recorded in incorrect or unnatural colors.
- If focusing is difficult with the autofocus mode when using the NightShot function, focus manually.

While using the NightShot function, you cannot use the following functions:

- Exposure
- PROGRAM AE
- White balance
- Fader*
- Digital effect*

* You cannot use these functions only in the NightShot +Slow shutter mode.

Shutter speed in the NightShot +Slow shutter mode

Indicator	Shutter speed
 (NIGHTSHOT1)	1/15
 (NIGHTSHOT2)	1/4

The +SLOW SHTR button does not work:

- while the fader function is set or in use
- while the digital effect function is in use
- when NIGHTSHOT is set to OFF
- in the MEMORY mode (DCR-TRV10 only)

NightShot Light

NightShot Light rays are infrared and so are invisible. The maximum shooting distance using the NightShot Light is about 10 feet (3 m). The shooting distance will be twice or more in the NightShot +Slow shutter mode.

Self-timer recording

You can make a recording with the self-timer. This mode is useful when you want to record yourself.

(1) Press SELFTIMER in the standby mode. The 

Checking the recording

- END SEARCH / EDITSEARCH / Rec Review

You can use these buttons to check the recorded picture or shoot so that the transition between the last recorded scene and the next scene you record is smooth.

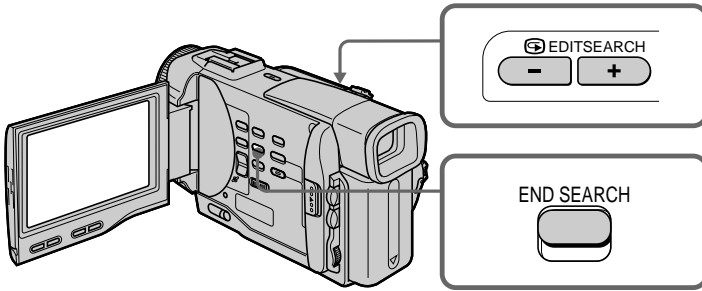

END SEARCH

You can go to the end of the recorded section after you record.

Press END SEARCH in the standby mode.

The last 5 seconds of the recorded section are played back and playback stops. You can monitor the sound from the speaker or headphones.

EDITSEARCH

You can search for the next recording start point.

Hold down the +/- side of EDITSEARCH in the standby mode. The recorded section is played back.

- + : to go forward
- : to go backward

Release EDITSEARCH to stop playback. If you press START/STOP, re-recording begins from the point you released EDITSEARCH. You cannot monitor the sound.

Rec Review

You can check the last recorded section.

Press the - side of EDITSEARCH momentarily in the standby mode.

The last few seconds of the recorded section are played back. You can monitor the sound from the speaker or headphones.

End search function

When you use a tape without cassette memory, the end search function does not work once you eject the cassette after you have recorded on the tape. If you use a tape with cassette memory, the end search function works even once you eject the cassette.

If there is a blank portion in the recorded portion, the end search function may not work correctly. (p. 109)

Playing back a tape

You can monitor the playback picture on the LCD screen. If you close the LCD panel, you can monitor the playback picture in the viewfinder. You can control playback using the Remote Commander supplied with your camcorder.

- (1) Install the power source and insert the recorded tape.
- (2) Set the POWER switch to VTR while pressing the small green button. The video control buttons light up.
- (3) Slide OPEN. Then, open the LCD panel.
- (4) Press ◀◀ to rewind the tape.
- (5) Press ▶ to start playback.
- (6) To adjust the volume, press either of the two buttons on VOLUME. The speaker on your camcorder is silent when the LCD panel is closed.

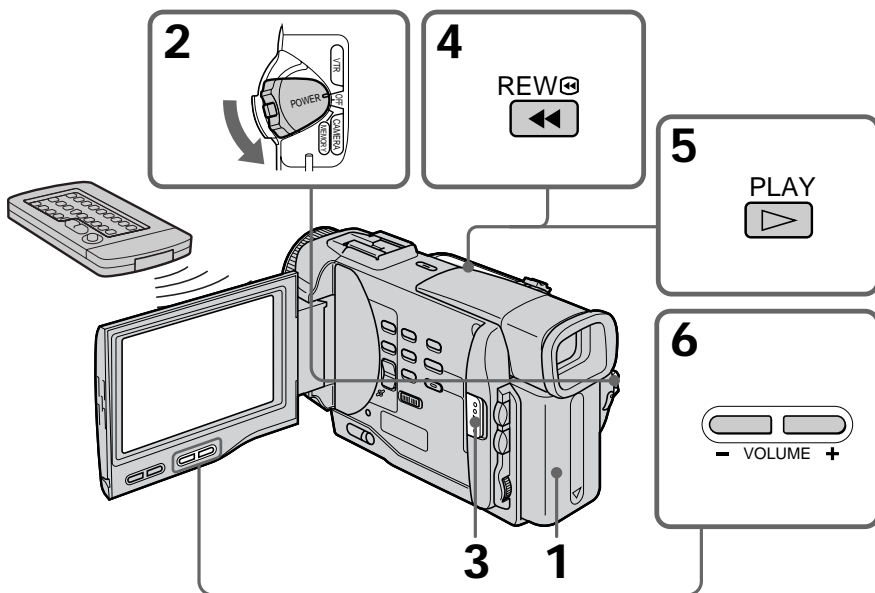

To stop playback

Press ■.

When monitoring on the LCD screen

You can turn the LCD panel over and move it back to the camcorder body with the LCD screen facing out.

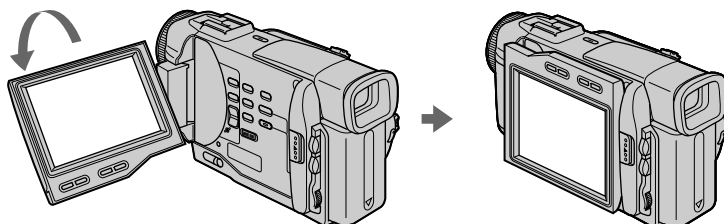

Playing back a tape

To display the screen indicators – Display function

Press DISPLAY on your camcorder or the Remote Commander supplied with your camcorder.

The indicators appear on the LCD screen.

To make the indicators disappear, press DISPLAY again.

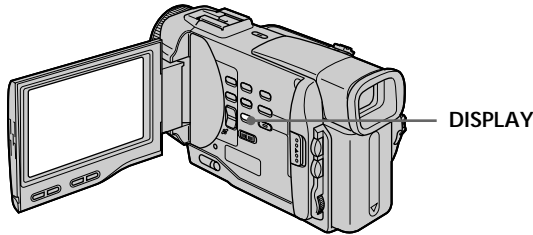

Using the data code function

Your camcorder automatically records not only images on the tape but also the recording data (date/time or various settings when recorded) (**Data code**). Data code is not displayed during recording. You can only operate with the Remote Commander.

Press DATA CODE on the Remote Commander in the playback mode.

The display changes as follows:

date/time → various settings (SteadyShot, white balance, gain, shutter speed, aperture value) → no indicator

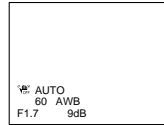
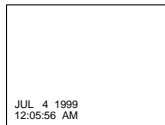

Not to display various settings

Set DATA CODE to DATE in the MENU settings (p. 72).

The display changes as follows:

date/time → no indicator

Note

The pictures taken on the Memory Stick are not recorded with various settings.

Recording data

Recording data is your camcorder's information when you have recorded. In the recording mode, the recording data will not be displayed.

When you use data code function, bars (-- -- --) appear if:

- A blank section of the tape is being played back.
- The tape is unreadable due to tape damage or noise.
- The tape was recorded by a camcorder without the date and time set.

Data code

The data code is displayed on the TV screen if you connect your camcorder to the TV (p. 28).

Various playback modes

To operate control buttons, set the POWER switch to VTR.

To view a still picture (playback pause)

Press **II** during playback. To resume playback, press **II** or **▶**.

To advance the tape

Press **▶▶** in the stop mode. To resume normal playback, press **▶**.

To rewind the tape

Press **◀◀** in the stop mode. To resume normal playback, press **▶**.

To change the playback direction

Press **<** on the Remote Commander during playback to reverse the playback direction. To resume normal playback, press **▶**.

To locate a scene monitoring the picture (picture search)

Keep pressing **◀◀** or **▶▶** during playback. To resume normal playback, release the button.

To monitor the high-speed picture while advancing or rewinding the tape (skip scan)

Keep pressing **◀◀** while rewinding or **▶▶** while advancing the tape. To resume rewinding or advancing, release the button.

To view the picture at slow speed (slow playback)

Press **▶** on the Remote Commander during playback. For slow playback in the reverse direction, press **<**, then press **▶** on the Remote Commander. To resume normal playback, press **▶**.

To view the picture at double speed

Press **×2** on the Remote Commander during playback. For double speed playback in the reverse direction, press **<**, then press **×2** on the Remote Commander. To resume normal playback, press **▶**.

To view the picture frame-by-frame

Press **II▶** on the Remote Commander in the playback pause mode. For frame-by-frame playback in the reverse direction, press **◀II**. To resume normal playback, press **▶**.

To search the last scene recorded (END SEARCH)

Press **END SEARCH** in the stop mode. The last 5 seconds of the recorded section plays back and stops.

End Search

When you use a tape without cassette memory, the end search function does not work once you eject the cassette after you have recorded on the tape.

When you use a tape with cassette memory, the end search function works even once you eject the cassette.

In the various playback modes

Sound is muted.

When the playback pause mode lasts for 5 minutes

Your camcorder automatically enters the stop mode. To resume playback, press **▶**.

Slow playback

The slow playback can be performed smoothly on your camcorder; however, this function does not work for an output signal from the **i** DV IN/OUT jack.

When you play back a tape in reverse

Horizontal noise appears at the center or top and bottom of the screen. This is not a malfunction.

Viewing the recording on TV

Connect your camcorder to your TV or VCR with the A/V connecting cable supplied with your camcorder to watch the playback picture on the TV screen. You can operate the playback control buttons in the same way as when you monitor playback pictures on the LCD screen. When monitoring the playback picture on the TV screen, we recommend that you power your camcorder from a wall outlet using the AC power adaptor (p. 13). Refer to the operating instructions of your TV or VCR.

Open the jack cover. Connect your camcorder to the TV using the A/V connecting cable. Then, set the TV/VCR selector on the TV to VCR.

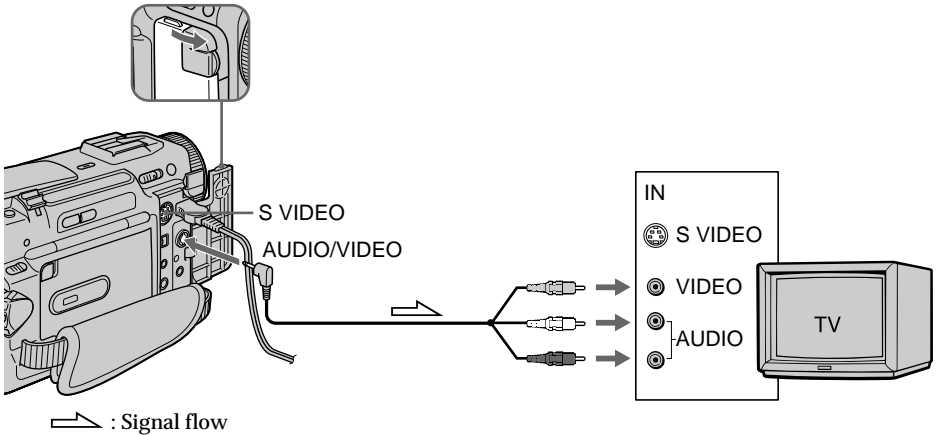

If your TV is already connected to a VCR

Connect your camcorder to the LINE IN input on the VCR by using the A/V connecting cable supplied with your camcorder. Set the input selector on the VCR to LINE.

If your TV or VCR is a monaural type

Connect the yellow plug of the A/V connecting cable to the video input jack and the white or the red plug to the audio input jack on the VCR or the TV. If you connect the white plug, the sound is L (left) signal. If you connect the red plug, the sound is R (right) signal.

If your TV or VCR has an S video jack

Connect using an S video cable (not supplied) to obtain high-quality pictures. With this connection, you do not need to connect the yellow (video) plug of the A/V connecting cable.

Connect the S video cable (not supplied) to the S video jacks on both your camcorder and the TV or the VCR.

Refer to the operating instructions of your TV.

This connection produces higher quality DV format pictures.

Using the AV cordless IR receiver

Once you connect the AV cordless IR receiver (not supplied) to your TV or VCR, you can easily view the picture on your TV. For details, refer to the operating instructions of the AV cordless IR receiver.

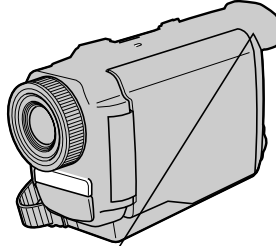

- (1) After connecting your TV and AV cordless IR receiver, set the POWER switch on the AV cordless IR receiver to ON.
- (2) Turn the TV on and set the TV/VCR selector on the TV to VCR.
- (3) Press LASER LINK. The lamp of LASER LINK lights up.
- (4) Press ► on your camcorder to start playback.
- (5) Point the LASER LINK emitter at the AV cordless IR receiver. Adjust the position of your camcorder and the AV cordless IR receiver to obtain clear playback pictures.

To cancel the laser link function

Press LASER LINK. The lamp on the LASER LINK button goes out.

If you turn the power off

Laser link turns off automatically.

If you use a Sony TV

- You can turn on the TV automatically when you press LASER LINK or ►. To do so, set AUTO TV ON to ON in the MENU settings and turn the TV's main switch on, then do either of the following:
 - Point the LASER LINK emitter at the TV's remote sensor and press LASER LINK.
 - Turn on LASER LINK and press ►.
- You can switch the video input of the TV automatically to the one which the AV cordless IR receiver is connected. To do so, set AUTO TV ON to ON and TV INPUT to the same video input (1, 2, 3) in the MENU settings. With some models, however, the picture and sound may be disconnected momentarily when the video input is switched.
- The above feature may not work on some TV models.

Note

When laser link is activated (the LASER LINK button is lit), your camcorder consumes power. Press LASER LINK to turn off the laser link function when it is not needed.

Photo recording

You can record a still picture like a photograph. This mode is useful when you want to record a picture such as a photograph or when you print a picture using a video printer (not supplied).

You can record about 510 pictures in the SP mode and about 765 pictures in the LP mode on a 60-minute tape.

Besides the operation described here, your camcorder can record still pictures on Memory Sticks (p. 85) (DCR-TRV10 only).

(1) Set the POWER switch to CAMERA.

(2) In the standby mode, keep pressing PHOTO lightly until a still picture appears. The CAPTURE indicator appears. Recording does not start yet.

To change the still picture, release PHOTO, select a still picture again, and then press and hold PHOTO lightly.



(3) Press PHOTO deeper.

The still picture in the viewfinder or on the LCD screen is recorded for about seven seconds. The sound during those seven seconds is also recorded.

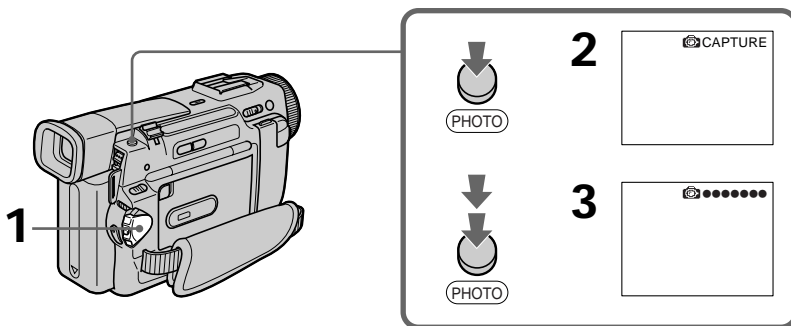
During recording, the still image you are shooting appears in the viewfinder or on the LCD screen.



Notes

- During photo recording, you cannot change the mode or setting.
- During photo recording, you cannot turn your camcorder off or press the PHOTO button.
- When recording a still picture, do not shake your camcorder. The picture may fluctuate.
- The photo recording function does not work:
 - while the fader function is set or in use
 - while the digital effect function is set or in use
- When  flashes, the appropriate brightness may not be obtained.
- When you start photo recording, from normal CAMERA recording, the video flash light (not supplied) does not work ( does not appear).

If you record a moving subject with photo recording function

When you play back the still picture on other equipment, the picture may fluctuate.

Photo recording

To use the photo recording function using the Remote Commander

Press PHOTO on the Remote Commander. Your camcorder records a picture on the LCD screen or in the viewfinder immediately.

To use the photo recording function during normal CAMERA recording

Press PHOTO deeper. The still picture is then recorded for about seven seconds and your camcorder returns to the standby mode. You cannot select another still picture.

Printing the still picture

You can print a still picture by using the video printer (not supplied). Connect the video printer using the A/V connecting cable supplied with your camcorder.

Connect it to the AUDIO/VIDEO jack and connect the yellow plug of the cable to the video input of the video printer. Refer to the operating instructions of the video printer as well.

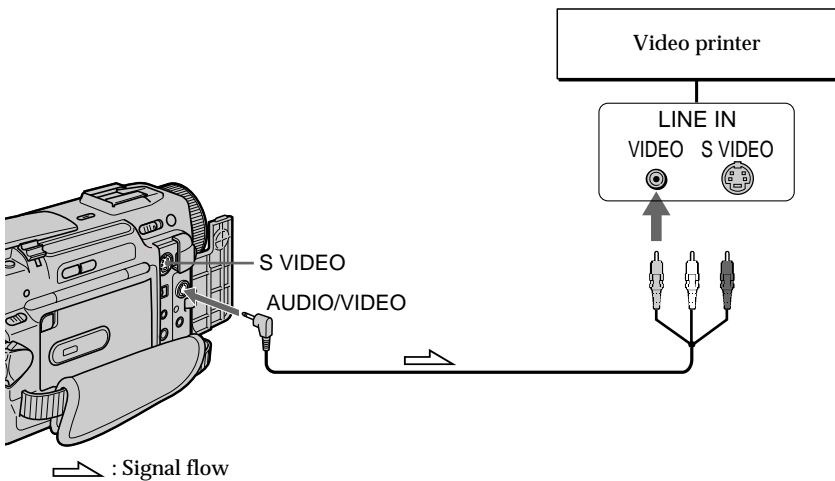

If the video printer is equipped with S video input

Use the S video connecting cable (not supplied). Connect it to the S VIDEO jack and the S video input of the video printer.

Using the wide mode

You can record a 16:9 wide picture to watch on the 16:9 wide-screen TV (16:9WIDE). Black bands appear on the screen during recording in 16:9WIDE mode [a]. The picture during playing back on a normal TV [b] or a wide -screen TV [c] are compressed in the widthwise direction. If you set the screen mode of the wide-screen TV to the full mode, you can watch pictures of normal images [d].

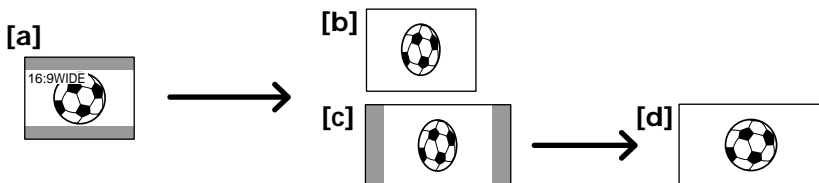

In the standby mode, set 16:9WIDE to ON in the MENU settings (p. 72).

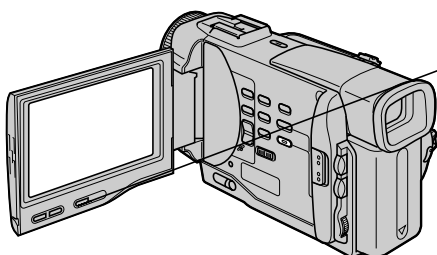

MENU

To cancel the wide mode

Set 16:9WIDE to OFF in the MENU settings.

In the wide mode

You cannot select the old movie function with DIGITAL EFFECT and the bounce function with FADER.

During recording

You cannot select or cancel the wide mode. When you cancel the wide mode, set your camcorder to the standby mode and then set 16:9WIDE to OFF.

Connection for a TV

Pictures recorded in the 16:9WIDE mode automatically appear on the TV screen at full size when you connect your camcorder to a TV that is compatible with the video ID (ID-1/ID-2) system.

ID-2 system

The ID-2 system sends a copyright protection signal with ID-1 signals inserted between video signals when you connect your camcorder to other equipment by an A/V connecting cable.

Using the fader function

You can fade in or out to give your recording a professional appearance.

[a] STBY REC

FADER

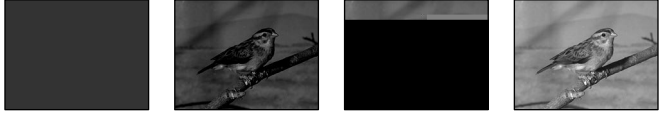

M.FADER
(mosaic)

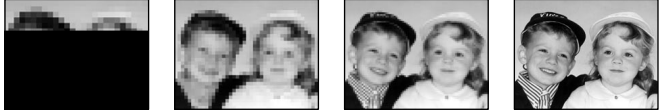

BOUNCE*
(Fade in only)



OVERLAP
(Fade in only)



[b] STBY REC

MONOTONE

When fading in, the picture gradually changes from black-and-white to color.
When fading out the picture gradually changes from color to black-and-white.

* You cannot use this function when D ZOOM is set to ON in the MENU settings.

Using the fader function

Note

You cannot use the following functions while using the fader function. Also, you cannot use the fader function while using the following functions.

- Digital effect
- Low lux mode of PROGRAM AE (Overlap function only)
- NightShot +Slow shutter
- Photo recording

When the OVERLAP indicator appears

Your camcorder automatically stores the image recorded on a tape. As the image is being stored, the OVERLAP indicator flashes fast, and the playback picture is displayed. At this stage, the picture may not be recorded clearly, depending on the tape condition.

When START/STOP MODE is set to $\frac{1}{2}$ or 5SEC

You cannot use the fader function.

While using the bounce function, you cannot use the following functions:

- Exposure
- Focus
- Zoom
- Picture effect

Note on the bounce function

The BOUNCE indicator does not appear in the following mode or functions:

- D ZOOM is set to ON in the MENU settings
- Wide mode
- Picture effect
- PROGRAM AE

Using special effects – Picture effect

You can digitally process images to obtain special effects like those in films or on the TV.

NEG. ART [a] : The color and brightness of the picture is reversed.

SEPIA : The picture is sepia.

B&W : The picture is monochrome (black-and-white).

SOLARIZE [b] : The light intensity is clearer, and the picture looks like an illustration.

SLIM [c] : The picture expands vertically.

STRETCH [d] : The picture expands horizontally.

PASTEL [e] : The contrast of the picture is emphasized, and the picture looks like an animated cartoon.

MOOSAIC [f] : The picture is mosaic.

[a]



[b]



[c]



[d]



[e]



[f]



Select the desired picture effect mode in the MENU settings (p. 72).

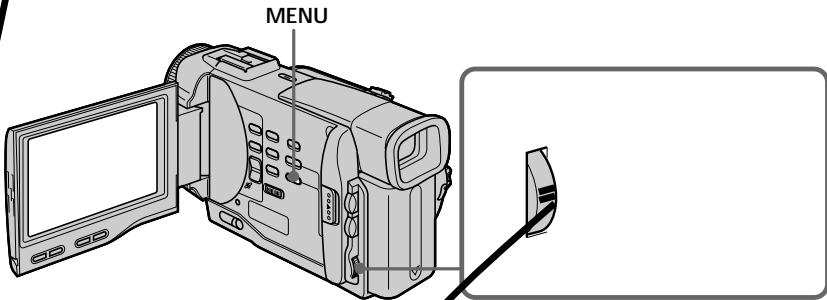

To turn the picture effect function off

Set P EFFECT to OFF in the MENU settings.

During playback, you can process a scene using the picture effect function

The available picture effects are NEG. ART, SOLARIZE, SEPIA and B&W.

Using special effects – Picture effect

While using the picture effect function

You cannot select the old movie mode with DIGITAL EFFECT.

When you turn the power off

Your camcorder automatically returns to the normal mode.

If you select the picture effect mode in the recording mode

Pictures processed by the picture effect function will be recorded.

When the POWER switch is set to VTR

The SLIM, STRETCH, PASTEL and MOSAIC indicators do not appear in the MENU settings.

Using special effects – Digital effect

You can add special effects to recorded pictures using the various digital functions. The sound is recorded normally.

STILL

You can record a still picture so that it is superimposed on a moving picture.

FLASH (FLASH MOTION)

You can record still pictures successively at constant intervals.

LUMI. (LUMINANCEKEY)

You can swap a brighter area in a still picture with a moving picture.

TRAIL

You can record the picture so that an incidental image like a trail is left.

SLOW SHTR (SLOW SHUTTER)

You can slow down the shutter speed. The slow shutter mode is good for recording dark pictures more brightly. However, the picture may be less clear.

OLD MOVIE

You can add an old movie type atmosphere to pictures. Your camcorder automatically sets the wide mode to ON, picture effect to SEPIA, and the appropriate shutter speed.

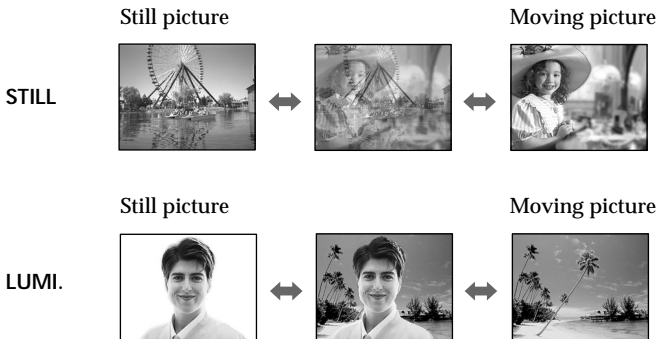

Using special effects – Digital effect

- (1) While your camcorder is in the standby or recording mode, press DIGITAL EFFECT. The digital effect indicator appears.
- (2) Turn the SEL/PUSH EXEC dial to select the desired digital effect mode. The indicator changes as follows:
STILL ↔ FLASH ↔ LUMI. ↔ TRAIL ↔ SLOW SHTR ↔ OLD MOVIE
- (3) Press the SEL/PUSH EXEC dial. The indicator lights up and the bars appear. In the STILL and LUMI. modes, the still picture is stored in memory.
- (4) Turn the SEL/PUSH EXEC dial to adjust the effect.

Items to adjust

STILL	The rate of the still picture you want to superimpose on the moving picture
FLASH	The interval of flash motion
LUMI.	The color scheme of the area in the still picture which is to be swapped with a moving picture
TRAIL	The vanishing time of the incidental image
SLOW SHTR	Shutter speed. The larger the shutter speed number, the slower the shutter speed.
OLD MOVIE	No adjustment necessary

The more bars there are on screen, the stronger the digital effect. The bars appear in the following modes: STILL, FLASH, LUMI. and TRAIL.

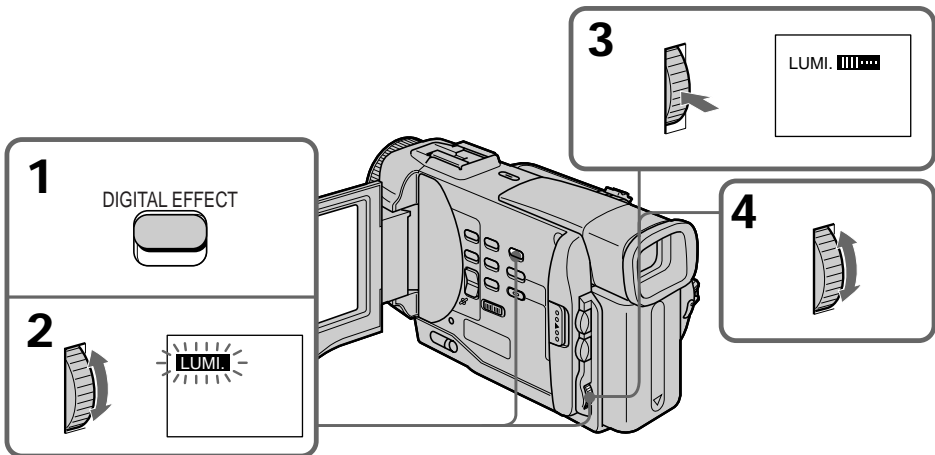

To cancel the digital effect

Press DIGITAL EFFECT. The digital effect indicator disappears.

Using special effects – Digital effect

Notes

- The following functions do not work during digital effect:
 - Fader
 - Low lux mode of PROGRAM AE
 - Photo recording
 - NightShot +Slow shutter
- The following function does not work in the slow shutter mode:
 - PROGRAM AE
- The following functions do not work in the old movie mode:
 - Wide mode
 - Picture effect
 - PROGRAM AE

When you turn the power off

The digital effect will be automatically canceled.

When recording in the slow shutter mode

Auto focus may not be effective. Focus manually using a tripod.

Shutter speed

Shutter speed number	Shutter speed
SLOW SHTR 1	1/30
SLOW SHTR 2	1/15
SLOW SHTR 3	1/8
SLOW SHTR 4	1/4

Adjusting the white balance manually

You can manually adjust and set the white balance. This adjustment makes white subjects look white and allows more natural color balance. Normally white balance is automatically adjusted.

In the standby or recording mode, select the desired white balance mode in the MENU settings. (p. 72)

The selected white balance indicator appears.

AUTO (Automatic white balance mode) : no indication

HOLD (Hold mode) : HOLD

OUTDOOR (Outdoor mode) : ☀

INDOOR (Indoor mode) : ☹

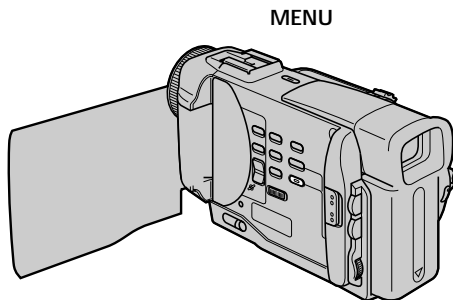

To return to the automatic white balance mode

Set WHT BAL to AUTO in the MENU settings.

Cases that you can obtain better results by adjusting the white balance manually

Examples of picture-taking conditions	White balance indicator
<ul style="list-style-type: none"> • If the lighting conditions, like those at a party, are changing. • If the picture is being taken in a studio lit by TV lighting. • If the subject is being lit by sodium- or mercury-vapor lamps. 	☹
<ul style="list-style-type: none"> • At night-time with neon or fireworks in the picture • At sunrise or sunset • Under daytime-fluorescent light 	☀
<ul style="list-style-type: none"> • If the subject or background is all the same color. 	HOLD

If the picture is being taken in a studio lit by TV lighting

We recommend you to record in the indoor mode.

When you record under fluorescent lighting

Use the automatic white balance or hold mode.

Your camcorder may not adjust the white balance correctly in the indoor mode.

To record when lighting conditions change

- When you move from indoors to outdoors, or vice versa, or detach the battery for replacement while recording in the automatic white balance mode, point your camcorder at a white subject for about 10 seconds after setting the POWER switch to CAMERA.
- When you move from indoors to outdoors, or vice versa, or change the PROGRAM AE mode while recording in the hold mode, set the white balance to AUTO and reset to HOLD after few seconds.

Using the PROGRAM AE function

You can select PROGRAM AE (Auto Exposure) mode to suit your specific shooting requirements.

 **Spotlight mode**

This mode prevents people's faces, for example, from appearing excessively white when shooting subjects lit by strong light at weddings or in the theater.

 **Soft portrait mode**

This mode brings out the subject while creating a soft background for subjects such as people or flowers, and faithfully reproduces skin color.

 **Sports lesson mode**

This mode minimizes shake on fast-moving subjects such as in tennis or golf.

 **Beach & ski mode**

This mode prevents people's faces from appearing dark in strong light or reflected light, such as at a beach in midsummer or on a ski slope.

 **Sunset & moon mode**

This mode allows you to maintain atmosphere when you are recording sunsets, general night views, fireworks displays and neon signs.

 **Landscape mode**

This mode is for when you are recording distant subjects such as mountains and prevents your camcorder from focusing on glass or metal mesh in windows when you are recording a subject behind glass or a screen.

 **Low lux mode**

This mode makes subjects brighter in insufficient light.



Using the PROGRAM AE function

- (1) Press PROGRAM AE in the standby mode. The PROGRAM AE indicator appears.
- (2) Turn the SEL/PUSH EXEC dial to select the desired PROGRAM AE mode. The indicator changes as follows:

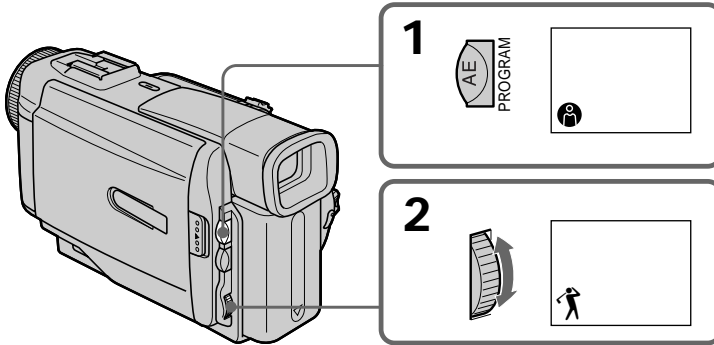

To turn the PROGRAM AE function off

Press PROGRAM AE.

Notes

- In the spotlight, sports lesson and beach & ski modes, you cannot take close-ups. This is because your camcorder is set to focus only on subjects in the middle to far distance.
- In the sunset & moon and landscape modes, your camcorder is set to focus only on distant subjects.
- The following functions do not work in the PROGRAM AE mode:
 - Slow shutter
 - Old movie
 - Bounce
- The following functions do not work in the low lux mode:
 - Digital effect
 - Overlap
- If you press PROGRAM AE when using the NightShot function, the PROGRAM AE indicator flashes and the PROGRAM AE function does not work.

While WHT BAL is set to AUTO in the MENU settings

The white balance is adjusted even if the PROGRAM AE function is selected.

Even if the PROGRAM AE function is selected

You can adjust the exposure.

If you are recording under a discharge tube such as a fluorescent lamp, sodium lamp or mercury lamp

Flickering or changes in color may occur in the following modes. If this happens, turn the PROGRAM AE function off.

- Soft portrait mode
- Sports lesson mode

Adjusting the exposure manually

You can manually adjust and set the exposure. Adjust the exposure manually in the following cases:

- The subject is backlit
- Bright subject and dark background
- To record dark pictures (e.g. night scenes) faithfully

- (1) Press EXPOSURE in the standby or recording mode.
The exposure indicator appears.
- (2) Turn the SEL/PUSH EXEC dial to adjust the brightness.

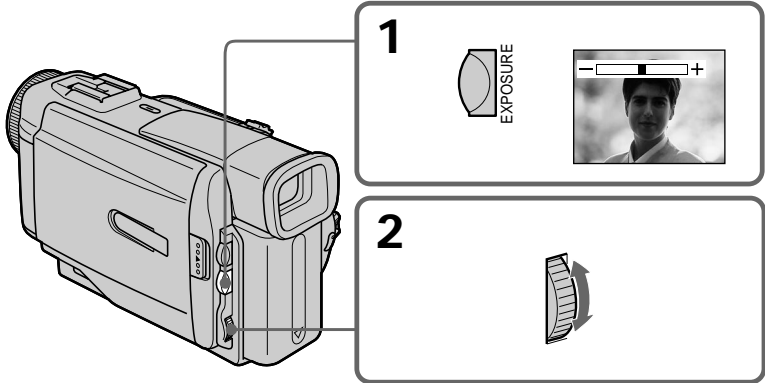

To return to the automatic exposure mode

Press EXPOSURE again.

Note

When you adjust the exposure manually, the backlight function does not work.

If you change the PROGRAM AE mode or slide NIGHTSHOT to ON

Your camcorder automatically returns to the automatic exposure mode.

Focusing manually

You can gain better results by manually adjusting the focus in the following cases:

- The autofocus mode is not effective when shooting
 - subjects through glass coated with water droplets
 - horizontal stripes
 - subjects with little contrast with backgrounds such as walls and sky
- When you want to change the focus from a subject in the foreground to a subject in the background
- Shooting a stationary subject when using a tripod

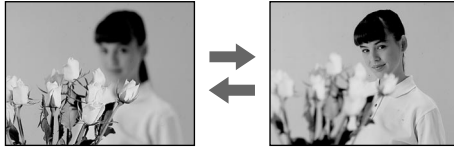

- (1) Set FOCUS to MANUAL in the standby or recording mode. The ∞ indicator appears.
- (2) Turn the focus ring to sharpen focus.

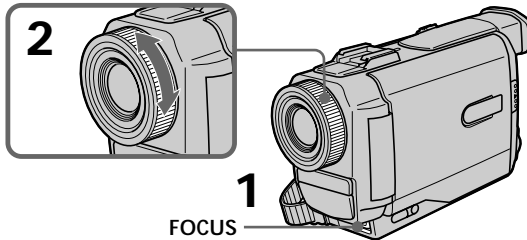

To return to the autofocus mode

Set FOCUS to AUTO.

To record distant subjects

When you press FOCUS down to INFINITY. The lens focuses on and \blacktriangle indicator appears. When you release FOCUS, your camcorder returns to the manual focus mode. Use this mode when your camcorder focuses on near objects even though you are trying to shoot a distant object.

Not to make subjects out of focus when using zoom function

Focus after focusing at the “T” (telephoto) position.

It will be harder to focus on when using digital zoom function.

Shooting in relatively dark places or shooting fast-moving subjects in relatively bright places

Shoot at the “W” (wide-angle) position after focusing at the “T” (telephoto) position.

When you shoot close to the subject

Focus at the end of the “W” (wide-angle) position.

The following indicators may appear

- \blacktriangle when recording a distant subject.
- \blacktriangle when the subject is too close to focus on.

Playing back a tape with picture effects

During playback, you can process a scene using the picture effect functions: NEG.ART, SOLARIZE, SEPIA and B&W.

During playback, select the desired picture effect mode in the MENU settings (p. 72). For details of each picture effect function, see page 36.

MENU

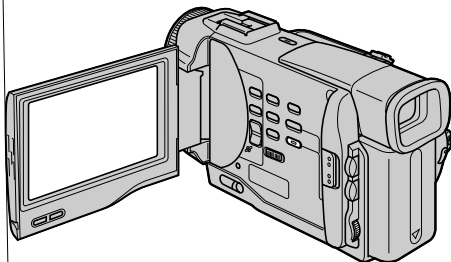

To cancel the picture effect function

Set P EFFECT to OFF in the MENU settings.

Notes

- You cannot process externally input scenes using the picture effect function.
- To record pictures that you have processed using the picture effect function, record the pictures on the VCR using your camcorder as a player.

Pictures processed by the picture effect function

Pictures processed by the picture effect function are not output through the DV IN/OUT jack.

When you set the POWER switch to OFF or stop playing back

The picture effect function is automatically canceled.

Playing back a tape with digital effects

During playback, you can process a scene using the digital effect functions: STILL, FLASH, LUMI. and TRAIL.

- (1) During playback, press DIGITAL EFFECT and turn the SEL/PUSH EXEC dial until the desired digital effect indicator (STILL, FLASH, LUMI. or TRAIL) flashes.
- (2) Press the SEL/PUSH EXEC dial.
The digital effect indicator lights up and the bars appear. In the STILL or LUMI. mode, the picture where you press the SEL/PUSH EXEC dial is stored in memory as a still picture.
- (3) Turn the SEL/PUSH EXEC dial to adjust the effect.
For details of each digital effect function, see page 38.

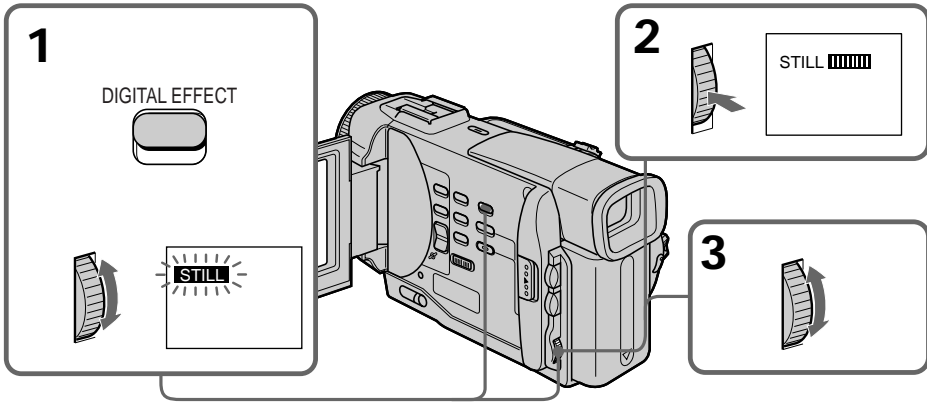

To cancel the digital effect function

Press DIGITAL EFFECT.

Notes

- You cannot process externally input scenes using the digital effect function.
- To record pictures that you have processed using the digital effect, record the pictures on the VCR using your camcorder as a player.

Pictures processed by the digital effect function

Pictures processed by the digital effect function are not output through the  DV IN/OUT jack.

When you set the POWER switch to OFF or stop playing back

The digital effect function is automatically canceled.

Quickly locating a scene using the zero set memory function

Your camcorder goes forward or backward to automatically stop at a desired scene having a tape counter value of "0:00:00". You can do this with the Remote Commander. Use this function, for example, to view a desired scene later on during playback.

- (1) In the playback mode, press DISPLAY.
- (2) Press ZERO SET MEMORY at the point you want to locate later. The tape counter shows "0:00:00" and the ZERO SET MEMORY indicator flashes.
- (3) Press ■ when you want to stop playback.
- (4) Press ◀◀ to rewind the tape to the tape counter's zero point. The tape stops automatically when the tape counter reaches approximately zero. The ZERO SET MEMORY indicator disappears and the time code appears.
- (5) Press ▶▶. Playback starts.

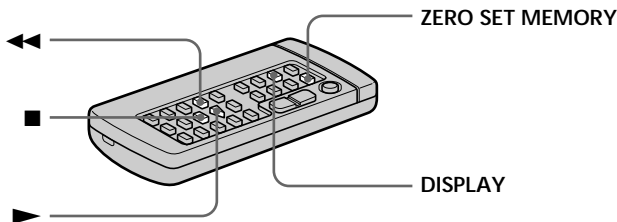

Notes

- When you press ZERO SET MEMORY before rewinding the tape, the zero set memory function will be canceled.
- There may be a discrepancy of several seconds from the time code.
- The zero set memory function may not work when there is a blank portion between pictures on a tape.

ZERO SET MEMORY functions also in the recording standby mode

When you insert a scene in the middle of a recorded tape, press ZERO SET MEMORY at the point you want to end the insertion. Rewind the tape to the insert start point, and start recording. Recording stops automatically at the tape counter zero point. Your camcorder returns to the standby mode.

Searching a recording by date



- Date search

You can automatically search for the point where the recording date changes and start playback from that point (**Date search**). Use a tape with cassette memory for convenience. You can do this with the Remote Commander.

Use this function to check where recording dates change or to edit the tape at each recording date.

Searching for the date by using cassette memory

You can use this function only when playing back a tape with cassette memory (p. 109).

- (1) Set the POWER switch to VTR.
- (2) Set CM SEARCH in  to ON in the MENU settings (p. 72). Factory setting is ON.
- (3) Press SEARCH MODE repeatedly, until the date search indicator appears.
The indicator changes as follows:
TITLESEARCH → DATESEARCH → PHOTOSEARCH → PHOTOSCAN
→ no indicator
- (4) Press  or  to select the date for playback.
Your camcorder automatically starts playback at the beginning of the selected date.

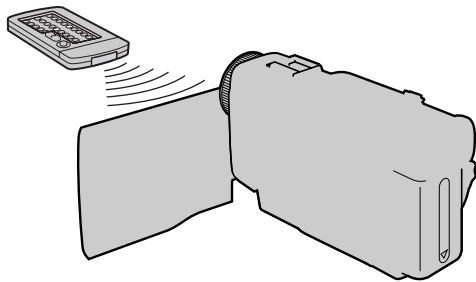





To stop searching

Press .

Searching a recording by date

Searching for the date without using cassette memory

- (1) Set the POWER switch to VTR.
- (2) Set CM SEARCH in  to OFF in the MENU settings (p. 72).
- (3) Press SEARCH MODE repeatedly, until the date search indicator appears.
The indicator changes as follows:
DATESEARCH → PHOTO SEARCH → PHOTO SCAN → no indicator
- (4) Press  to search for the previous date or press  to search for the next date. Your camcorder automatically starts playback at the point where the date changes. Each time you press  or , your camcorder searches for the previous or next date.

To stop searching

Press .

Notes

- If one day's recording is less than two minutes, your camcorder may not accurately find the point where the recording date changes.
- The cursor in the  mark indicates the present point on the tape.

If a tape has a blank portion between recorded portions

The date search function may not work correctly.



Cassette memory

The tape cassette memory can hold six recording date data.

Searching the boundaries of recorded tape by title – Title search

CM
only

If you use a tape with cassette memory, you can search for the boundaries of recorded tape by title (Title search). Use the Remote Commander for this operation.

- (1) Set the POWER switch to VTR.
- (2) Set CM SEARCH in  to ON in the MENU settings (p. 72). Factory setting is ON.
- (3) Press SEARCH MODE repeatedly, until the title search indicator appears.
- (4) Press  or  to select the title for playback.

Your camcorder automatically starts playback of the scene having the title that you selected.

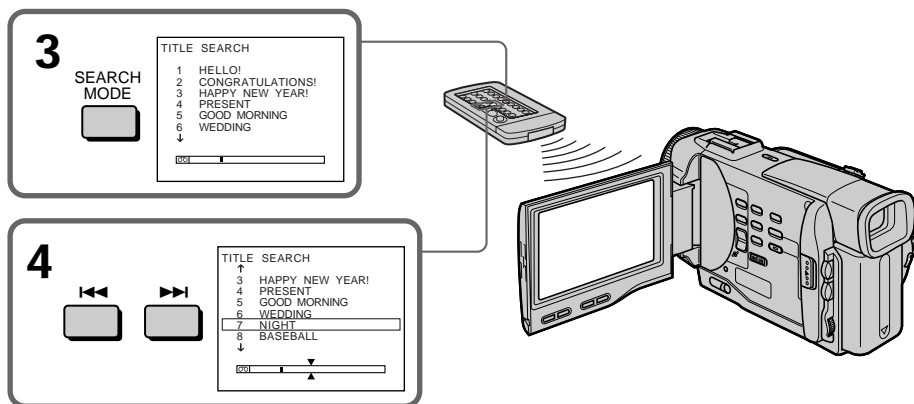

To stop searching

Press .

If you use a tape without cassette memory
You cannot superimpose or search a title.

To superimpose a title

See page 65.



If a tape has a blank portion between recorded portions
The title search function may not work correctly.

Searching for a photo – Photo search/ Photo scan

You can search for a still picture you have recorded on a mini DV tape (**photo search**). You can also search for still pictures one after another and display each picture for five seconds automatically regardless of cassette memory (**photo scan**). Use the Remote Commander for these operations. Use this function to check or edit still pictures.

Searching for a photo by using cassette memory

You can use this function only when playing back a tape with cassette memory (p. 109).

- (1) Set the POWER switch to VTR.
- (2) Set CM SEARCH in  to ON in the MENU settings (p. 72). Factory setting is ON.
- (3) Press SEARCH MODE repeatedly, until the photo search indicator appears. The indicator changes as follows:
TITLE SEARCH → DATE SEARCH → PHOTO SEARCH → PHOTO SCAN
→ no indicator
- (4) Press  or  to select the date for playback. Your camcorder automatically starts playback of the photo having the date that you selected.

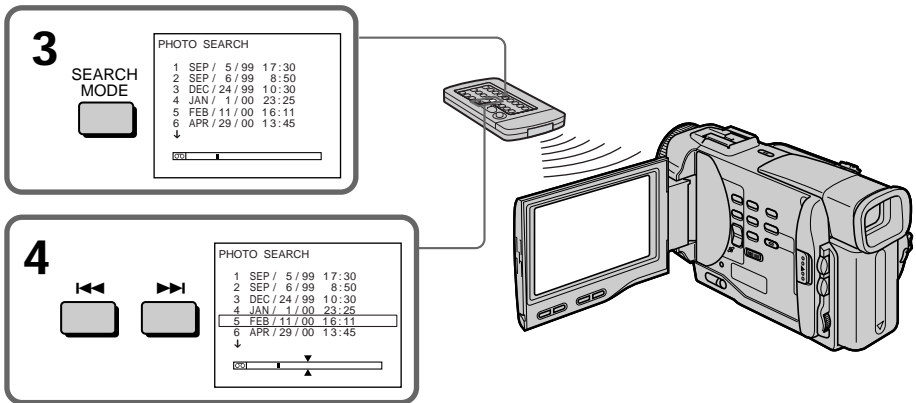





To stop searching

Press .

If a tape has a blank portion between recorded portions
The photo search function may not work correctly.

Searching for a photo – Photo search/Photo scan



Searching for a photo without using cassette memory

- (1) Set the POWER switch to VTR.
- (2) Set CM SEARCH in  to OFF in the MENU settings (p. 72).
- (3) Press SEARCH MODE repeatedly, until the photo search indicator appears.
- (4) Press  or  to select the photo for playback. Each time you press  or , your camcorder searches for the previous or next photo.
Your camcorder automatically starts playback of the photo.

To stop searching

Press .

Scanning photo

- (1) Set the POWER switch to VTR.
 - (2) Press SEARCH MODE repeatedly, until the photo scan indicator appears.
 - (3) Press  or .
- Each photo is played back for about 5 seconds automatically.

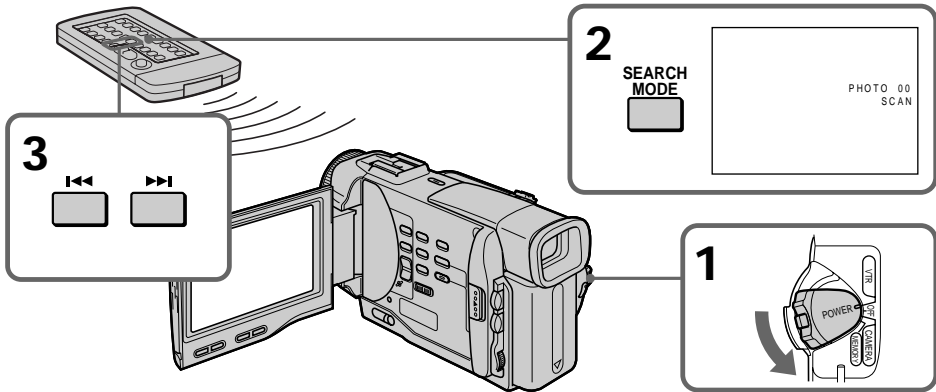

To stop scanning

Press .

Dubbing a tape

Using the A/V connecting cable

Connect your camcorder to the VCR using the A/V connecting cable supplied with your camcorder.

Set the input selector on the VCR to LINE, if available.

- (1) Insert a blank tape (or a tape you want to record over) into the VCR, and insert the recorded tape into your camcorder.
- (2) Set the POWER switch to VTR.
- (3) Play back the recorded tape on your camcorder.
- (4) Start recording on the VCR.

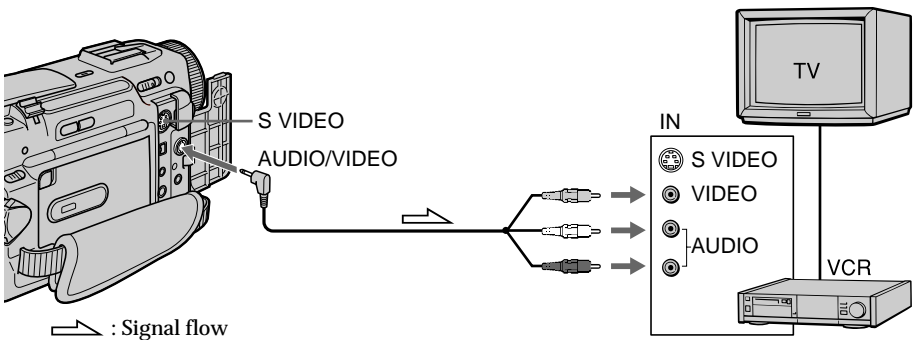

When you have finished dubbing a tape

Press **■** on both your camcorder and the VCR.

If you have displayed the screen indicators on the TV

Make the indicators disappear by pressing SEARCH MODE or DATA CODE on the Remote Commander or DISPLAY so that they will not be superimposed on the edited tape.

You can edit on VCRs that support the following systems

8 8 mm, **Hi8** Hi8, **D** Digital8, **VHS** VHS, **S-VHS** S-VHS, **VHS-C** VHS-C, **S-VHS-C** S-VHS-C, **β** Betamax, **ED β** ED Betamax, **Mini DV** mini DV or **DV** DV

If your VCR is a monaural type

Connect the yellow plug of the A/V connecting cable to the video input jack and the white or the red plug to the audio input jack on the VCR or the TV. When the white plug is connected, the left channel audio is output, and the red plug is connected, the right channel audio is output.

Connect using an S video cable (not supplied) to obtain high-quality pictures

With this connection, you do not need to connect the yellow (video) plug of the A/V connecting cable.

Connect an S video cable (not supplied) to the S video jacks of both your camcorder and the VCR.

This connection produces higher quality DV format pictures.

Using the i.LINK cable (DV connecting cable)

Simply connect the VMC-IL4435/2DV/4DV i.LINK cable (DV connecting cable) (not supplied) to **i** DV IN/OUT and to DV IN/OUT of the DV products. With digital-to-digital connection, video and audio signals are transmitted in digital form for high-quality editing. You cannot dub the titles, display indicators or the contents of cassette memory.

- (1) Insert a blank tape (or a tape you want to record over) into the VCR, and insert the recorded tape into your camcorder.
- (2) Set the POWER switch to VTR.
- (3) Play back the recorded tape on your camcorder.
- (4) Start recording on the VCR.

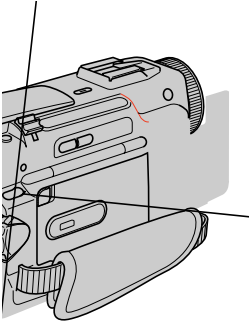

When you have finished dubbing a tape

Press **■** (STOP) on both your camcorder and the VCR.

You can connect one VCR only using the i.LINK cable (DV connecting cable).

During digital editing

You cannot use DIGITAL EFFECT button functions.

You can also use your camcorder as a recorder

You can use your camcorder as a player or recorder without changing the connection. When you use your camcorder as a recorder, the DV IN indicator appears in the viewfinder or on the LCD screen. The DV IN indicator may appear on both equipment.

If you record playback pause picture with the **i** DV IN/OUT jack

The recorded picture becomes rough. And when you play back the picture using the other video equipment, the picture may jitter.

To perform a more precise editing (DCR-TRV10 only)

Use DV synchro-editing function (p. 56).

Editing partially on a DV tape

- DV synchro-editing (DCR-TRV10 only)

By simply selecting the scenes to edit, you can duplicate the desired portion on a tape, using other equipment connected with an i.LINK cable (DV connecting cable). The scenes can be selected by frame. Since your camcorder exchanges digital signals, you can edit with little audio and video deterioration.

You cannot duplicate titles, display indicators, or the contents of cassette memory. The connection is the same as on page 55.

- (1) Insert a recorded tape into your camcorder and insert a blank tape (or a tape you want to record over) into the DV product.
- (2) Set the POWER switch of your camcorder to VTR.
- (3) Set the input selector to DV input on the DV product. If the DV product is another DV camcorder, set its POWER switch to VTR.
- (4) Press MENU to display the menu.
- (5) Turn the SEL/PUSH EXEC dial to select $\boxed{\text{ETC}}$, then press the dial.
- (6) Turn the SEL/PUSH EXEC dial to select DV EDITING, then press the dial.
- (7) Using the video control buttons, locate the point where you want to start editing, then press **II** to set your camcorder in the playback pause mode (p. 130).
- (8) Press the SEL/PUSH EXEC dial or MARK on the Remote Commander to set DV EDITING IN.
- (9) Using the video control buttons, locate the point where you want to end editing, then press **II** to set your camcorder in the playback pause mode.
- (10) Press the SEL/PUSH EXEC dial or MARK on the Remote Commander to set DV EDITING OUT. The editing process starts. When the process ends, your camcorder and the DV product automatically set to pause mode.

Editing partially on a DV tape – DV synchro-editing (DCR-TRV10 only)

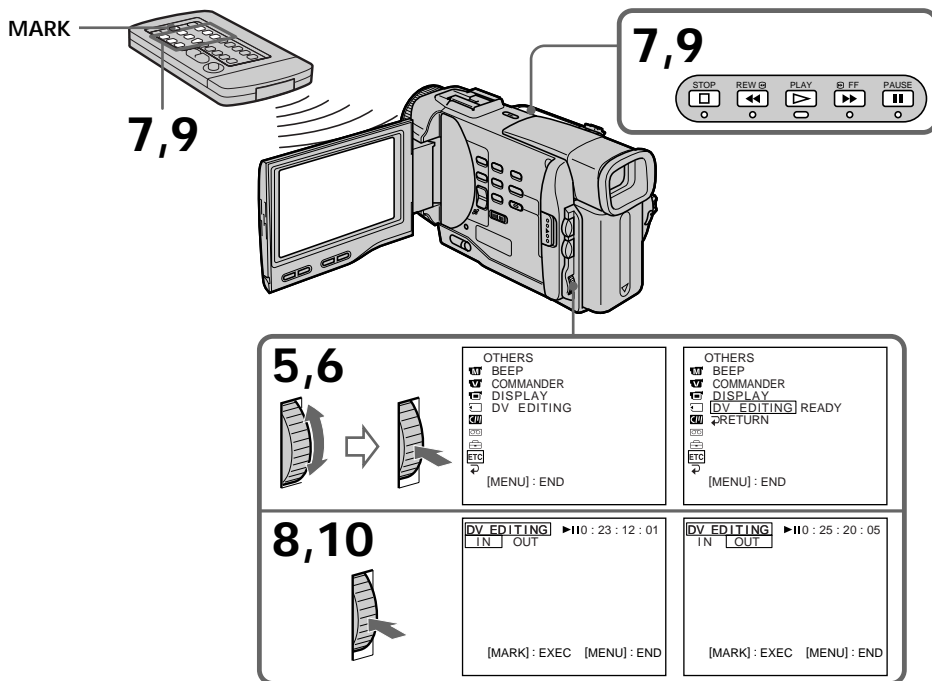

Notes

- If you use other than Sony equipment with the DV jack, you cannot perform DV synchro-editing.
- If a tape has a blank portion between recorded portions, DV synchro-editing may not work correctly.

Errors in duplicating

If you connect your camcorder to Sony equipment with DV jack, the range of errors is within +/- 5 frames. The range may become wider in the following conditions.

- The interval between DV EDITING IN and OUT is less than five seconds.
- DV EDITING IN or OUT is set at the beginning of the tape.

If you do not make connections with i.LINK cable (DV connecting cable)

The screen shows NOT READY, and you cannot select DV EDITING.

On a blank portion of the tape

You cannot set DV EDITING IN or OUT.

Recording video or TV programs

You can record a tape from another VCR or a TV program from a TV that has video/audio outputs. Use your camcorder as a recorder. Turn down the volume of your camcorder. Otherwise, the picture may be distorted.

- (1) Insert a blank tape (or a tape you want to record over) into your camcorder. If you are recording a tape from the VCR, insert a recorded tape into the VCR.
- (2) Set the POWER switch to VTR.
- (3) Set DISPLAY to LCD in the MENU settings (p. 72). The picture from a TV or VCR appears in the viewfinder or on the LCD screen.
- (4) Press ● REC and the button on its right simultaneously on your camcorder, then immediately press || on your camcorder.
- (5) Press ► on the VCR to start playback if you are recording a tape from VCR. Select a TV program if you are recording from TV.
- (6) Press || on your camcorder at the scene where you want to start recording from.

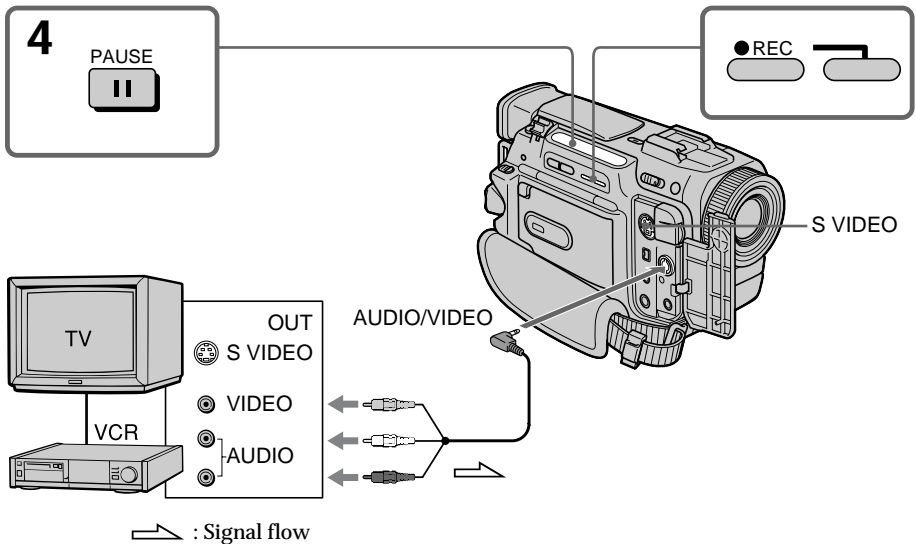

Note

If you fast-forward or slow-playback on the other equipment, the image being recorded may turn black and white. When recording from other equipment, be sure to play back the original tape at normal speed.

If your VCR is a monaural type

Connect the yellow plug of the A/V connecting cable to the video output jack and the white or the red plug to the audio output jack on the VCR or the TV. When the white plug is connected, the left channel audio is output, and the red plug is connected, the right channel audio is output.

Connect using an S video cable (not supplied) to obtain high-quality pictures

With this connection, you do not need to connect the yellow (video) plug of the A/V connecting cable.

Connect an S video cable (not supplied) to the S video jacks of both your camcorder and the VCR.

This connection produces higher quality DV format pictures.

originally recorded tape by
the Remote Commander for this
page 54 or 55.
me to insert into the VCR.



Inserting a scene from a VCR

- (1) Set the POWER switch to VTR.
- (2) On the VCR, locate just before the insert start point [a], then press **II** to set the VCR to the playback pause mode.
- (3) On your camcorder, locate the insert end point [c] by pressing **◀◀** or **▶▶**. Then press **II** to set it to the playback pause mode.
- (4) Press ZERO SET MEMORY on the Remote Commander. The ZERO SET MEMORY indicator flashes and the end point of the insert is stored in memory.
- (5) On your camcorder, locate the insert start point [b] by pressing **◀◀**, then press two **● REC** buttons at same time to set your camcorder to the recording pause mode.
- (6) First press **II** on the VCR, and after a few seconds press **II** on your camcorder to start inserting the new scene.

Inserting automatically stops near the zero point on the tape counter. Your camcorder automatically returns to the stop mode.

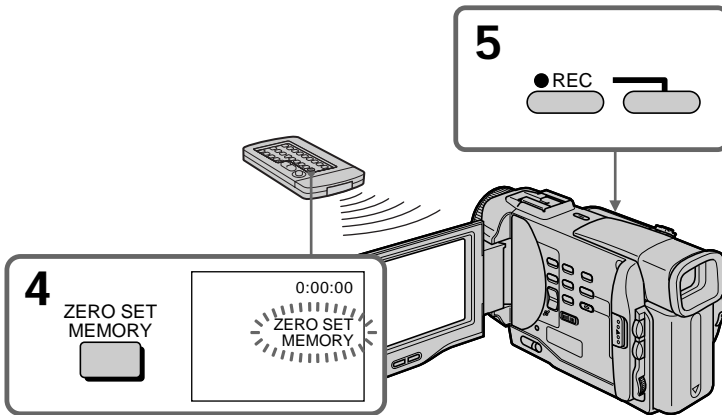

To change the insert end point

Press ZERO SET MEMORY again after step 5 to erase the ZERO SET MEMORY indicator and begin from step 3.

Note

The picture and sound recorded on the section between the insert start and end points will be erased when you insert the new scene.

When the inserted picture is played back

The picture and sound may be distorted at the end of the inserted section. This is not a malfunction.

To insert a scene without setting the insert end point

Skip step 3 and 4. Press **■** when you want to stop inserting.

Audio dubbing

You can record an audio sound to add to the original sound on a tape by connecting audio equipment or a microphone. If you connect the audio equipment, you can add sound to your recorded tape by specifying starting and ending points. The original sound will not be erased.

Use the Remote Commander for this operation.

Connecting the microphone with the MIC jack

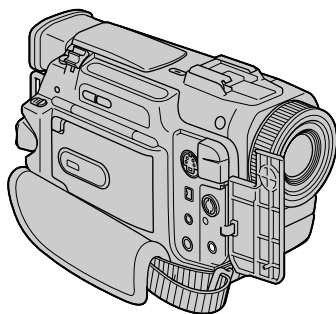

MIC
(PLUG IN
POWER)

: Signal flow

Microphone (not supplied)

You can check the recorded picture and sound by connecting the AUDIO/VIDEO jack to a TV.

The recorded sound is not output from a speaker. Check the sound by using the TV or headphones.

Connecting the microphone with the intelligent accessory shoe

Microphone (not supplied)

Audio dubbing

Dubbing with the AUDIO/VIDEO jack

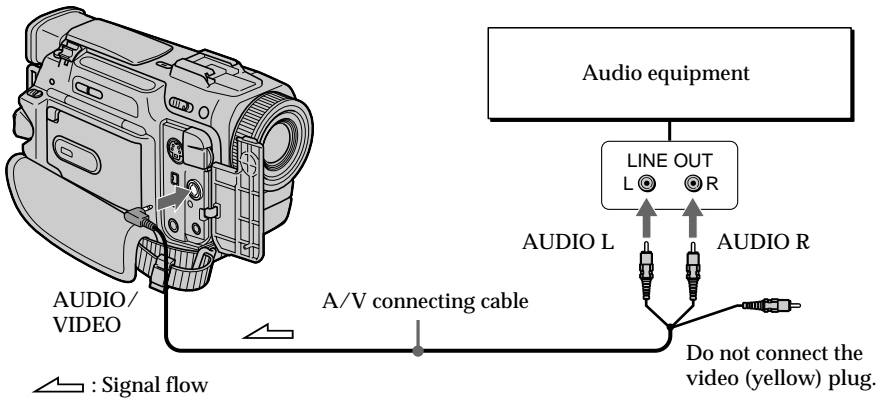

Note

The picture is not output from the AUDIO/VIDEO jack. Check the recorded picture on the LCD screen or in the viewfinder, as well as check the recorded sound by using a speaker or headphones.

Dubbing with the built-in microphones

No connection is necessary.

Note

The picture is not output from the AUDIO/VIDEO jack. Check the recorded picture on the LCD screen or in the viewfinder, as well as check the recorded sound by using a speaker or headphones.

Adding an audio sound on a recorded tape

- (1) Insert your recorded tape into your camcorder.
- (2) Set the POWER switch of your camcorder to VTR.
- (3) Locate the recording start point by pressing ►. Then press ■ at the point where you want to start recording to set your camcorder to playback pause mode.
- (4) Press AUDIO DUB on the Remote Commander .
- (5) Press ■ on the Remote Commander and at the same time start playing back the audio you want to record.
The new sound is recorded in stereo 2 (ST2) during playback.
- (6) Press ■ on the Remote Commander at the point where you want to stop recording.

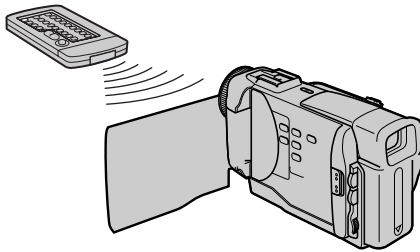

Monitoring the new recorded sound

To play back the sound

Adjust the balance between the original sound (ST1) and the new sound (ST2) by selecting AUDIO MIX in the MENU settings (p. 72).

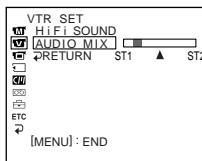

Five minutes after when you disconnect the power source or remove the battery pack, the setting of AUDIO MIX returns to the original sound (ST1) only. The factory setting is original sound only.

Audio dubbing

Notes

- New sound cannot be recorded on a tape already recorded in the 16-bit mode (32 kHz, 44.1 kHz or 48 kHz) (p. 76).
- When an external microphone is not connected, the recording will be made through the built-in microphone of your camcorder.
- New sound cannot be recorded on a tape already recorded in the LP mode.
- You cannot add audio with the  DV IN/OUT jack.

If you make all the connections

The audio input to be recorded will take precedence over others in the following order.

- MIC (PLUG IN POWER) jack
- Intelligent accessory shoe
- AUDIO/VIDEO jack
- Built-in microphone

If an i.LINK cable (DV connecting cable) is connected to your camcorder

You cannot add a sound to a recorded tape.

To add new sound more precisely

Press ZERO SET MEMORY at the point where you want to stop recording later in the playback mode.

Carry out steps 3 to 5. Recording automatically stops at the point where ZERO SET MEMORY was pressed.

We recommend you to add new sound on a tape recorded with your camcorder

If you add new sound on a tape recorded with another camcorder (including DCR-TRV8/TRV10), the sound quality may become worse.

If you disconnect or connect the i.LINK cable (DV connecting cable) to your camcorder during recording

The recording may stop.

Superimposing a title

CM
only

If you use a tape with cassette memory, you can superimpose the title while recording or after recording. When you play back the tape, the title is displayed for five seconds from the point where you superimposed it.

You can select one of eight preset titles and two custom titles (p. 68). You can also select the color, size and position of titles.



- (1) Press TITLE to display the title menu.
- (2) Turn the SEL/PUSH EXEC dial to select □, then press the dial.
- (3) Turn the SEL/PUSH EXEC dial to select the desired title, then press the dial. The title is flashing.
- (4) Change the color, size, or position, if necessary.
 - ① Turn the SEL/PUSH EXEC dial to select the color, size, or position, then press the dial. The item appears.
 - ② Turn the SEL/PUSH EXEC dial to select the desired item, then press the dial.
 - ③ Repeat steps ① and ② until the title is laid out as desired.
- (5) Press the SEL/PUSH EXEC dial again to complete the setting.

In the playback, playback pause or recording mode:

The "TITLE SAVE" indicator appears on the screen for 5 seconds and the title is set.

In the standby mode:

The "TITLE" indicator appears. And when you press START/STOP to start recording,

"TITLE SAVE" appears on the screen for 5 seconds and the title is set.

Superimposing a title

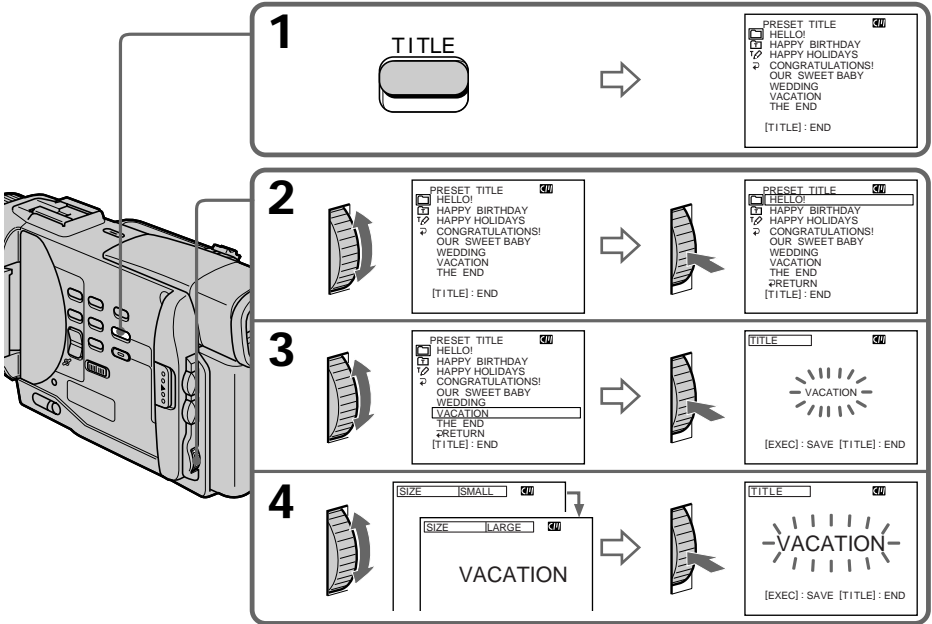

If you use a cassette set to prevent accidental erasure

You cannot superimpose or erase the title. Slide the write-protect tab so that the red portion is not visible.

To use the custom title

If you want to use the custom title, select  in step 2.

If you have not made any custom title, “- - - - -” appears on the display.

Title setting

- The title color changes as follows :
WHITE ↔ YELLOW ↔ VIOLET ↔ RED ↔ CYAN ↔ GREEN ↔ BLUE
- The title size changes as follows :
SMALL ↔ LARGE
If you input 13 characters or more for a LARGE title, the title is automatically reduced in size after its position is set.
- The title position changes as follows :
1 ↔ 2 ↔ 3 ↔ 4 ↔ 5 ↔ 6 ↔ 7 ↔ 8 ↔ 9
The larger the position number, the lower the title is positioned.
When you select the title size “LARGE”, you cannot choose position 9.

One cassette can have up to about 26 titles, if one title consists of 5 characters. However, if the cassette memory is full with date, photo and cassette label data, one cassette can have only up to about 15 titles with 5 characters each.

Cassette memory capacity is as follows:

- 6 date data (maximum)
- 12 photo data (maximum)
- 1 cassette label (maximum)

Superimposing a title

Erasing a title

- (1) Set the POWER switch to VTR.
- (2) Press MENU to display the menu.
- (3) Turn the SEL/PUSH EXEC dial to select **[CM]**, then press the dial.
- (4) Turn the SEL/PUSH EXEC dial to select TITLEERASE, then press the dial.
Title erase display appears.
- (5) Turn the SEL/PUSH EXEC dial to select the title you want to erase, then press the dial.
“ERASE OK ?” indicator appears.
- (6) Make sure the title is the one you want to erase, and turn the SEL/PUSH EXEC dial to select ERASE, then press the dial.

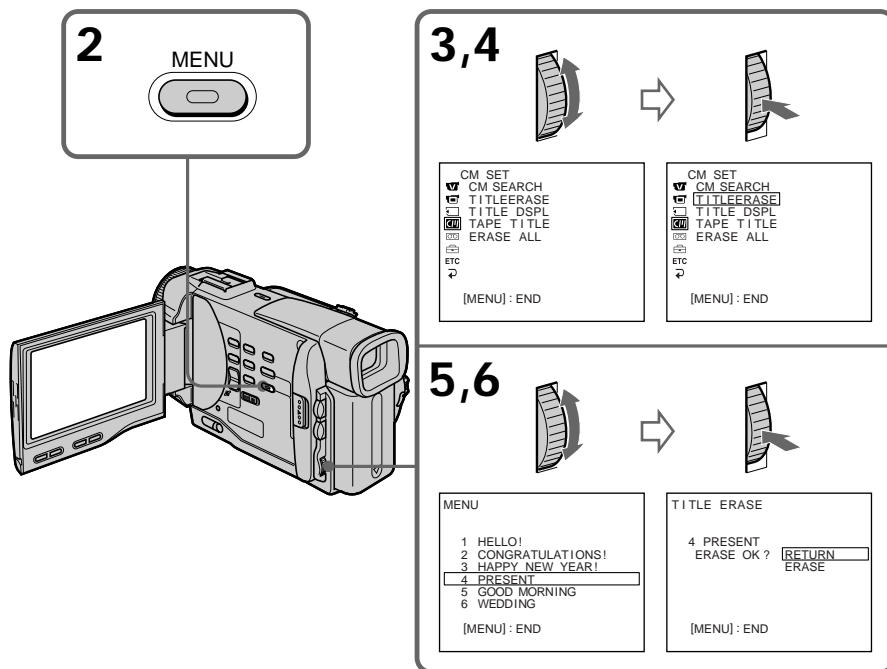

To erase the menu display

Press MENU.

Making your own titles

CM
only

You can make up to two titles and store them in the cassette memory. Each title can have up to 20 characters.

- (1) Press TITLE in the standby or VTR mode.
- (2) Turn the SEL/PUSH EXEC dial to select \uparrow/\emptyset , then press the dial.
- (3) Turn the SEL/PUSH EXEC dial to select the first line (CUSTOM1) or second line (CUSTOM2), then press the dial.
- (4) Turn the SEL/PUSH EXEC dial to select the column of the desired character, then press the dial.
- (5) Turn the SEL/PUSH EXEC dial to select the desired character, then press the dial.
- (6) Repeat steps 4 and 5 until you have selected all characters and completed the title.
- (7) To finish making your own titles, turn the SEL/PUSH EXEC dial to select [SET], then press the dial. The title is stored in memory.
- (8) Press TITLE to make the title menu disappear.

1

TITLE



PRESET TITLE

HELLO! HAPPY BIRTHDAY

HAPPY HOLIDAYS

CONGRATULATIONS!

OUR SWEET BABY

WEDDING

VACATION!

THE END

[TITLE]: END

2





TITLE SET CM

CUSTOM1

CUSTOM2

[TITLE]: END







TITLE SET CM

RETURN

[TITLE]: END



3



TITLE SET CM

RETURN

[TITLE]: END





TITLE SET CM

ABCDE 12345

FGHIJ 67890

KLMNO . / -

PQRST [+]

UVWXY [SET]

Z& ?!

[TITLE]: END



4

1



TITLE SET CM

ABCDE 12345

FGHIJ 67890

KLMNO . / -

PQRST [+]

UVWXY [SET]

Z& ?!

[TITLE]: END



6

2



TITLE SET CM

ABCDE 12345

FGHIJ 67890

KLMNO . / -

PQRST [+]

UVWXY [SET]

Z& ?!

[TITLE]: END



3

4



TITLE SET CM

S

ABCDE 12345

FGHIJ 67890

KLMNO . / -

PQRST [+]

UVWXY [SET]

Z& ?!

[TITLE]: END



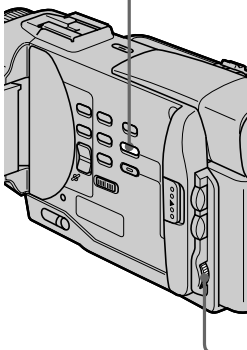

Making your own titles

To change a title you have stored

In step 3, select CUSTOM1 or CUSTOM2, depending on which title you want to change, then press the SEL/PUSH EXEC dial. Turn the SEL/PUSH EXEC dial to select [←], then press the dial to delete the title. The last character is erased. Enter the new title as desired.

If you take 5 minutes or longer to enter characters in the standby mode while a cassette is in your camcorder

The power automatically goes off. The characters you have entered remain stored in memory. Set the POWER switch to OFF once and then to CAMERA again, then proceed from step 1.

We recommend setting the POWER switch to VTR or removing the cassette so that your camcorder does not automatically turn off while you are entering title characters.

To delete the title

Select [←]. The last character is erased.

Labeling a cassette

If you use a tape with cassette
 consist of up to 10 characters
 the labeled cassette and turn
 screen, in the viewfinder, or

- (1) Insert the cassette you want to
- (2) Set the POWER switch to VTR.
- (3) Press MENU to make the menu
- (4) Turn the SEL/PUSH EXEC dial
- (5) Turn the SEL/PUSH EXEC dial
- (6) Turn the SEL/PUSH EXEC dial
 then press the dial.
- (7) Turn the SEL/PUSH EXEC dial to
 dial.
- (8) Repeat steps 6 and 7 until you fini
- (9) Turn the SEL/PUSH EXEC dial to
 The label is stored in memory.

. The label can
 When you insert
 d on the LCD

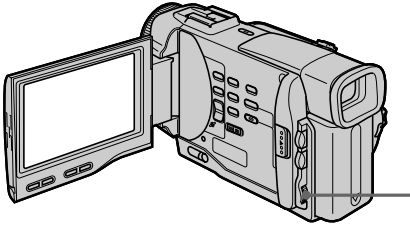

6-8

4,5

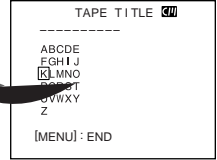
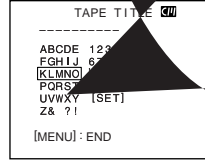
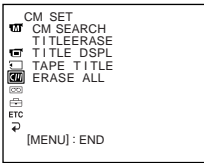

Labeling a cassette

To erase a character

In step 6 turn the SEL/PUSH EXEC dial to select [←], then press the dial. The last character is erased.

To change the label you have made

Insert the cassette to change the label, and operate in the same way to make a new label.

If you use a cassette set to prevent accidental erasure

You cannot label it. Slide the write-protect tab so that the red portion is not visible.

If the mark appears in step 5

The cassette memory is full. If you erase the title in the cassette, you can label it.

If you have superimposed titles in the cassette

When the label is displayed, up to 4 titles also appear.

When the "-----" indicator has fewer than 10 spaces

The cassette memory is full.

The "-----" indicates the number of characters you can select for the label.

Changing the MENU settings

To change the mode settings in the MENU settings, select the menu items with the SEL/PUSH EXEC dial. The factory settings can be partially changed. First, select the icon, then the menu item and then the mode.

- (1) In the standby or VTR mode, press MENU.
- (2) Turn the SEL/PUSH EXEC dial to select the desired icon, then press the dial to set.
- (3) Turn the SEL/PUSH EXEC dial to select the desired item, then press the dial to set.
- (4) Turn the SEL/PUSH EXEC dial to select the desired mode, and press the dial to set.
- (5) If you want to change other items, select ↻ RETURN and press the dial, then repeat steps from 2 to 4.

For details, see “Selecting the mode setting of each item” (p. 73).

1

MENU

CAMERA

MANUAL SET
P EFFECT
WHT BAL
AUTO SHTR

[MENU] : END

VTR

MANUAL SET
P EFFECT

[MENU] : END

MEMORY

MANUAL SET
WHT BAL
AUTO SHTR

[MENU] : END

2

MANUAL SET
P EFFECT
WHT BAL

OTHERS

WORLD TIME
BEEP
COMMANDER
DISPLAY
REC LAMP

OTHERS

WORLD TIME 0 HR
BEEP
COMMANDER
DISPLAY
REC LAMP
RETURN

3

OTHERS

WORLD TIME 0 HR
BEEP

OTHERS

WORLD TIME
BEEP
COMMANDER ON
DISPLAY
REC LAMP
RETURN

OTHERS

WORLD TIME
BEEP
COMMANDER ON
DISPLAY OFF
REC LAMP
RETURN

4

OTHERS

WORLD TIME
BEEP
COMMANDER ON
DISPLAY OFF
REC LAMP
RETURN

OTHERS









WORLD TIME
BEEP
COMMANDER OFF
DISPLAY
REC LAMP
RETURN

Changing the MENU settings

To make the MENU display disappear



Press MENU.

Menu items are displayed as the following icons:

-  MANUAL SET
-  CAMERA SET
-  VTR SET
-  LCD/VF SET
-  MEMORY SET (DCR-TRV10 only)
-  CM SET
-  TAPE SET
-  SETUP MENU
-  OTHERS

Selecting the mode setting of each item ● is the factory setting.

Menu items differ depending on the position of the POWER switch.

Icon/item	Mode	Meaning	POWER switch
 P EFFECT		To add special effects like those in films or on the TV to images (p. 36)	CAMERA VTR
	WHT BAL	To adjust the white balance (p. 41)	CAMERA MEMORY
AUTO SHTR	● ON	To automatically activate the electronic shutter when shooting in bright conditions	CAMERA MEMORY
	OFF	To not automatically activate the electronic shutter even when shooting in bright conditions	
 D ZOOM	ON	To activate digital zoom. More than 10× to 120× zoom is performed digitally (p. 19)	CAMERA MEMORY
	● OFF	To deactivate digital zoom. Up to 10× zoom is carried out.	
16:9WIDE	● OFF	—	CAMERA
	ON	To record a 16:9 wide picture (p. 32)	
STEADYSHOT	● ON	To compensate for camera-shake	CAMERA MEMORY
	OFF	To cancel the SteadyShot function. Natural pictures are produced when shooting a stationary object with a tripod.	
N.S. LIGHT	● ON	To use the NightShot Light function (p. 22)	CAMERA MEMORY
	OFF	To cancel the NightShot Light function	





Notes on the SteadyShot function

- The SteadyShot function will not correct excessive camera-shake.
- Attachment of a conversion lens (not supplied) may influence the SteadyShot function.

If you cancel the SteadyShot function

The SteadyShot off indicator  appears. Your camcorder prevents excessive compensation for camera-shake.

Changing the MENU settings

Icon/item	Mode	Meaning	POWER switch
 HIFI SOUND	● STEREO	To play back a stereo tape or dual sound track tape with main and sub sound	VTR
	1	To play back a stereo tape with the left sound or a dual sound tape with main sound	
	2	To play back a stereo tape with the right sound or a dual sound track tape with sub sound	
AUDIO MIX		To adjust the balance between the stereo 1 and stereo 2 (p. 63)	VTR
			
 LCD B. L.	● BRT NORMAL	To set the brightness on the LCD screen normal	VTR CAMERA MEMORY
	BRIGHT	To brighten the LCD screen	
LCD COLOR		To adjust the color on the LCD screen, turn and press the SEL/PUSH EXEC dial	VTR CAMERA MEMORY
		 <p>To lighten ← → To darken</p>	
VF BRIGHT		To adjust the brightness on the viewfinder screen, turn and press the SEL/PUSH EXEC dial	VTR CAMERA MEMORY
		 <p>To darken ← → To lighten</p>	



Note on AUDIO MIX

When playing back a tape recorded in the 16-bit mode, you cannot adjust the balance.



Notes on LCD B.L.

- When you select “BRIGHT”, battery life is reduced by about 10 percent during recording.
- When you use power sources other than the battery pack, “BRIGHT” is automatically selected.

Changing the MENU settings

Icon/item	Mode	Meaning	POWER switch
 CONTINUOUS (DCR-TRV10 only)	● OFF	Not to record continuously	MEMORY
	ON	To record 3 or 4 pictures continuously (p. 86)	
	MULTI SCRN	To record 9 pictures continuously (p. 86)	
QUALITY (DCR-TRV10 only)	● FINE	To record still pictures in the fine image quality mode, using the Memory Stick	VTR MEMORY
	STANDARD	To record still pictures in the standard image quality mode, using the Memory Stick	
FLD./FRAME (DCR-TRV10 only)	● FIELD	To record moving subjects	MEMORY
	FRAME	To record stopping subjects in high quality	
PRINT MARK (DCR-TRV10 only)	ON	To write a print mark on the recorded still images you want to print out later	VTR MEMORY
	● OFF	Not to write print marks on still pictures	
PROTECT (DCR-TRV10 only)	ON	To protect selected still pictures against accidental erasure (p. 100)	VTR MEMORY
	● OFF	Not to protect still pictures	
SLIDE SHOW (DCR-TRV10 only)		To play back images in a continuous loop (p. 107)	MEMORY
DELETE ALL (DCR-TRV10 only)		To delete all the images (p. 102)	MEMORY
FORMAT (DCR-TRV10 only)		To format Memory Sticks	MEMORY
PHOTO SAVE (DCR-TRV10 only)		To duplicate still pictures (p. 91)	VTR
 CM SEARCH	● ON	To search using cassette memory (p. 49)	VTR
	OFF	To search without using cassette memory	
TITLEERASE		To erase the title you have superimposed (p. 67)	VTR CAMERA
TITLE DSPL	● ON	To display the title you have superimposed	VTR
	OFF	Not to display the title	
TAPE TITLE		To label a cassette (p. 70)	VTR CAMERA
ERASE ALL		To erase all the data in cassette memory	VTR CAMERA

Changing the MENU settings

Icon/item	Mode	Meaning	POWER switch
 REC MODE	● SP	To record in the SP (Standard Play) mode	VTR CAMERA
	LP	To increase the recording time to 1.5 times the SP mode	
AUDIO MODE	● 12BIT	To record in the 12-bit mode (two stereo sounds)	VTR CAMERA
	16BIT	To record in the 16-bit mode (the one stereo sound with high quality)	
 REMAIN	● AUTO	To display the remaining tape bar: <ul style="list-style-type: none"> • for about 8 seconds after your camcorder is turned on and calculates the remaining amount of tape • for about 8 seconds after a cassette is inserted and your camcorder calculates the remaining amount of tape • for about 8 seconds after ► is pressed in VTR mode • for about 8 seconds after DISPLAY is pressed to display the screen indicators • for the period of tape rewinding, forwarding or picture search in the VTR mode 	VTR CAMERA
	ON	To always display the remaining tape indicator	
DATA CODE	● DATE/CAM	To display date, time and various settings during playback	VTR
	DATE	To display date and time during playback	



Notes on the LP mode

- When you record a tape in the LP mode on your camcorder, we recommend playing the tape on your camcorder. When you play back the tape on other camcorders or VCRs, noise may occur in pictures or sound.
- When you record in the LP mode, we recommend using a Sony Excellence/Master mini DV cassette so that you can get the most out of your camcorder.
- You cannot make audio dubbing on a tape recorded in the LP mode. Use the SP mode for the tape to be audio dubbed.
- When you record in the SP and LP modes on one tape or you record some scenes in the LP mode, the playback picture may be distorted or the time code may not be written properly between scenes.

Notes on AUDIO MODE

- You cannot dub audio sound on a tape recorded in the 16BIT mode.
- When playing back a tape recorded in the 16-bit mode, you cannot adjust the balance in AUDIO MIX.

Changing the MENU settings

Icon/item	Mode	Meaning	POWER switch
 CLOCK SET		To reset the date or time (p. 78)	CAMERA MEMORY
AUTO TV ON	● OFF ON	— To automatically turn on the Sony TV when using the laser link function	VTR CAMERA
TV INPUT	● VIDEO1 VIDEO2 VIDEO3 OFF	To switch the video input on a Sony TV when using the laser link function (p. 29) —	VTR CAMERA
LTR SIZE	● NORMAL 2×	To display selected menu items in normal size To display selected menu items at twice the normal size	VTR CAMERA MEMORY
DEMO MODE	● ON OFF	To make the demonstration appear To cancel the demonstration mode	CAMERA
 WORLD TIME		To set the clock to the local time. Turn the SEL/PUSH EXEC dial to set a time difference. The clock changes by the time difference you set here. If you set the time difference to 0, the clock returns to the originally set time.	CAMERA MEMORY
BEEP	● MELODY NORMAL OFF	To output the melody when you start/stop recording or when an unusual condition occurs on your camcorder To output the beep instead of the melody To cancel the melody and beep sound	VTR CAMERA MEMORY
COMMANDER	● ON OFF	To activate the Remote Commander supplied with your camcorder To deactivate the Remote Commander to avoid remote control misoperation caused by other VCR's remote control	VTR CAMERA MEMORY
DISPLAY	● LCD V-OUT/LCD	To show the display on the LCD screen and viewfinder To show the display on the TV screen, LCD screen and viewfinder	VTR CAMERA MEMORY
REC LAMP	● ON OFF	To light up the camera recording lamp at the front of your camcorder To turn the camera recording lamp off so that the subject is not aware of the recording	CAMERA MEMORY
DV EDITING (DCR-TRV10 only)		To duplicate the desired portion on a tape by simply selecting the scenes to edit, using other equipment connected with an i.LINK cable (DV connecting cable) (p. 56)	VTR

Notes on DEMO MODE

- You cannot select DEMO MODE when a cassette is inserted in your camcorder.
- DEMO MODE is set to STBY (Standby) at the factory and the demonstration starts about 10 minutes after you have set the POWER switch to CAMERA without a cassette inserted.
Note that you cannot select STBY of DEMO MODE in the MENU settings.
- When NIGHTSHOT is set to ON, the NIGHTSHOT indicator appears in the viewfinder or on the LCD screen and you cannot select DEMO MODE in the MENU settings.

In more than 5 minutes after removing the power source

The "AUDIO MIX", "COMMANDER" and "HiFi SOUND" items are returned to their factory settings.

The other menu items are held in memory even when the battery is removed.

Resetting the date and time

The clock is set to East Coast Standard Time at the factory.

If you do not use your camcorder for about a half year, the date and time settings may be released (bars may appear) because the vanadium-lithium battery installed in your camcorder will have been discharged.

First, set the year, then the month, the day, the hour and then the minute.

- (1) While your camcorder is in the standby mode, press MENU to display the MENU settings.
- (2) Turn the SEL/PUSH EXEC dial to select , then press the dial.
- (3) Turn the SEL/PUSH EXEC dial to select CLOCK SET, then press the dial.
- (4) Turn the SEL/PUSH EXEC dial to adjust the desired year, then press the dial.
- (5) Set the month, day and hour by turning the SEL/PUSH EXEC dial and pressing the dial.
- (6) Set the minute by turning the SEL/PUSH EXEC dial and pressing the dial by the time signal. The clock starts to move.
- (7) Press MENU to make the MENU settings disappear.

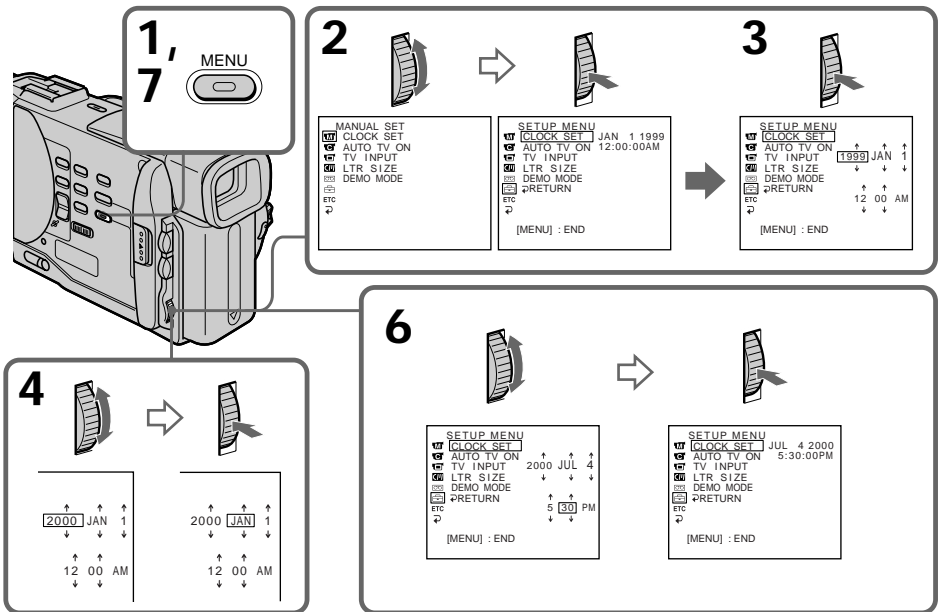

The year changes as follows:

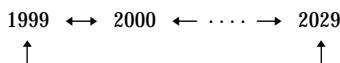

If you do not set the date and time

“--:--:--” is recorded on the tape and the Memory Stick (DCR-TRV10 only).

Note on the time indicator

The internal clock of your camcorder operates on a 12-hour cycle.

- 12:00 AM stands for midnight.
- 12:00 PM stands for noon.

Using a Memory Stick—introduction

– DCR-TRV10 only

You can record and play back still images on a Memory Stick supplied with your camcorder. You can easily play back, re-record or delete still images. You can also record images from a mini DV tape on a Memory Stick or vice versa. You can exchange image data with other equipment such as a personal computer etc., using the Serial port adaptor for Memory Stick supplied with your camcorder or MSAC-PC1 PC card adaptor for Memory Stick (not supplied).

Still images

Record the still image on a Memory Stick. Play back the picture with your PC. See page 96 for details.

Using a Memory Stick

When you use a Memory Stick

- You cannot record or erase still images when the write-protect tab on the Memory Stick is set to LOCK.
- You can format Memory Sticks. You can also protect still images and write print marks on still images in Memory Sticks.
- We recommend backing up important data.
- When the ACCESS lamp is flashing, never remove the Memory Stick.
- Image data may be damaged in the following cases:
 - If you remove the Memory Stick or turn the power off when the ACCESS lamp is flashing
 - If you use Memory Sticks near magnets or magnet fields such as those of speakers and televisions.

On file format (JPEG)

Your camcorder compresses image data in JPEG format (extension .jpg).

Typical image data file name

DSC00001.jpg.

Using a Memory Stick–introduction

Notes

- Prevent metallic objects or your finger from coming into contact with the metal parts of the connecting section.
- Stick its label on the labeling position.
- Do not bend, drop or apply strong shock to Memory Sticks.
- Do not disassemble or modify Memory Sticks.
- Do not let Memory Sticks get wet.
- Do not use or keep Memory Sticks in locations that are:
 - Extremely hot such as in a car parked in the sun or under the scorching sun
 - Under direct sunlight
 - Very humid or subject to corrosive gases
- When you carry or store a Memory Stick, put it in its case.

You do not need to format the Memory Stick supplied with your camcorder

The Memory Stick supplied with your camcorder is already formatted in FAT format. FAT format is the standard format for Memory Sticks and is supported by your camcorder.

Note

Sample images are already recorded on the Memory Stick supplied with your camcorder. All of these sample images will be deleted if you format the Memory Stick.

Memory Sticks formatted on a personal computer

Memory Stick operations on your camcorder cannot be assured if the Memory Stick is formatted on a Windows machine or Macintosh.

Notes on image data compatibility

- Image data files recorded on Memory Sticks by your camcorder conform with the Design Rules for Camera File Systems universal standard established by the JEIDA (Japan Electronic Industry Development Association). You cannot play back on your camcorder still images recorded on other equipment (DCR-TRV890/TRV900, DSC-D700) that does not conform with this universal standard. (These models are not sold in some areas.)
- If you cannot use a Memory Stick that has been used on other equipment, format the Memory Stick on your camcorder following the steps on page 84. Note that all images on the Memory Stick will be deleted if you format it.

Memory Stick is a trademark of Sony Corporation.

Using a Memory Stick–introduction

Inserting a Memory Stick

- (1) Slide MEMORY OPEN in the direction of the arrow. The Memory Stick compartment opens.
- (2) Insert a Memory Stick in as far as it can go with its rounded corner facing up. Then, close the Memory Stick compartment.

1

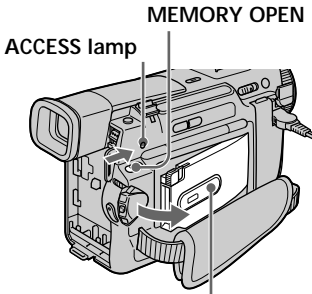

Memory Stick compartment

2

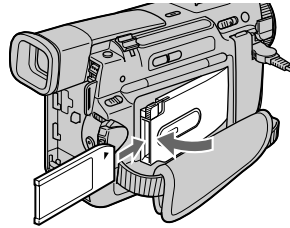

To eject a Memory Stick

Open the Memory Stick compartment in step 1, press MEMORY RELEASE. The Memory Stick comes out.

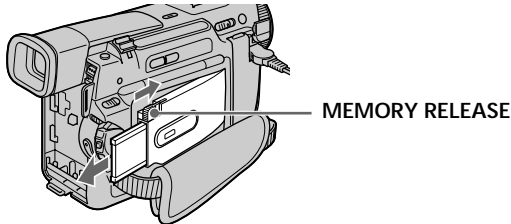

When the ACCESS lamp is lit or flashing

Never shake or strike your camcorder. Do not turn the power off, eject a Memory Stick or remove the battery pack. Otherwise, the image data breakdown may occur.

Using a Memory Stick-introduction

Selecting image quality mode

You can select image quality mode in still picture recording. If you do not make any selection, the unit automatically records in FINE mode.

- (1) Set the POWER switch to MEMORY. Make sure that the lock is set to the left (unlock) position.
- (2) Press MENU to make the MENU display appear.
- (3) Turn the SEL/PUSH EXEC dial to select , then press the dial.
- (4) Turn the SEL/PUSH EXEC dial to select QUALITY, then press the dial.
- (5) Turn the SEL/PUSH EXEC dial to select the desired image quality, then press the dial.
- (6) Press MENU to erase the menu display.

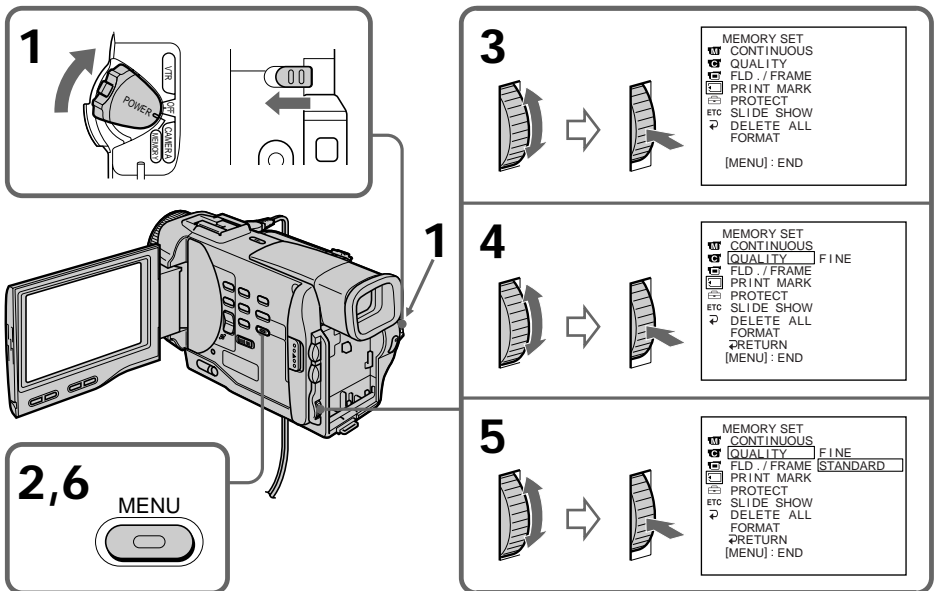

Using a Memory Stick–introduction

Image quality settings

Setting	Meaning
FINE (FINE)	Use this mode when you want to record high quality images. The image is compressed to about 1/6.
STANDARD (STD)	This is the standard image quality. The image is compressed to about 1/10.

Differences in image quality mode

Recorded images are compressed in JPEG format before being stored into memory. The memory capacity allotted to each image varies depending on the selected image quality mode. Details are shown in the table below. (The number of pixels is 640×480 , regardless of image quality mode. The data size before compression is about 600 KB.)

Image quality mode	Memory capacity
FINE	About 100 KB
STANDARD	About 60 KB

Approximate number of images you can record on a Memory Stick

The number of images you can record varies depending on which image quality mode you select and the complexity of the subject.

4MB type:

FINE (FINE)	40 images (maximum)
STANDARD (STD)	60 images (maximum)

8MB type:

FINE (FINE)	81 images (maximum)
STANDARD (STD)	122 images (maximum)

16MB type:

FINE (FINE)	164 images (maximum)
STANDARD (STD)	246 images (maximum)

Note

In some cases, changing the image quality mode may not affect the image quality, depending on the types of images you are shooting.

Using a Memory Stick–introduction

Your camcorder can format (initialize) a “Memory Stick”. If you format a “Memory Stick”, all data stored in the “Memory Stick” will be deleted. This function is convenient when you want to delete all data including protected images.

New “Memory Stick”s are already formatted so that formatting is not required for them.

Sample images are stored in the supplied “Memory Stick”. Note that these images will be deleted if you format the “Memory Stick”.

Formatting (initializing) a Memory Stick

- (1) Insert a Memory Stick into your camcorder.
- (2) Set the POWER switch to MEMORY. Make sure that the lock is set to the left (unlock) position.
- (3) Press MENU to make the MENU display appear.
- (4) Turn the SEL/PUSH EXEC dial to select \square , then press the dial.
- (5) Turn the SEL/PUSH EXEC dial to select FORMAT, then press the dial.
- (6) Turn the SEL/PUSH EXEC dial again to select OK, then press the dial. The display shows “EXECUTE.”
- (7) Press the SEL/PUSH EXEC dial. The display shows “FORMATTING,” and formatting procedure begins. When formatting is finished, the display shows “COMPLETE.”

Check the contents of the “Memory Stick” before formatting

Note that all data in the “Memory Stick” including protected images will be deleted.

While “FORMATTING” is displayed

Do not turn the POWER switch nor press any button.

Notes

You cannot format the Memory Stick if the write-protect tab on the Memory Stick is set to LOCK.

Recording still images on Memory Sticks – Memory photo recording

– DCR-TRV10 only

You can select the FIELD or FRAME mode in still picture recording. Your camcorder compensates for camera-shake when recording moving subjects in the FIELD mode. Your camcorder records still images in high quality in the FRAME mode. Select the FIELD or FRAME in the MENU settings (p. 72).

Before operation

Insert a Memory Stick into your camcorder.

- (1) Set the POWER switch to MEMORY. Make sure that the lock is set to the left (unlock) position.
- (2) Keep pressing PHOTO lightly. The picture freezes and “CAPTURE” appears on the LCD screen or in the viewfinder. Recording does not start yet.
- (3) Press PHOTO deeper. The image displayed on the screen will be recorded on a Memory Stick. Recording is complete when the bar scroll indicator disappears.

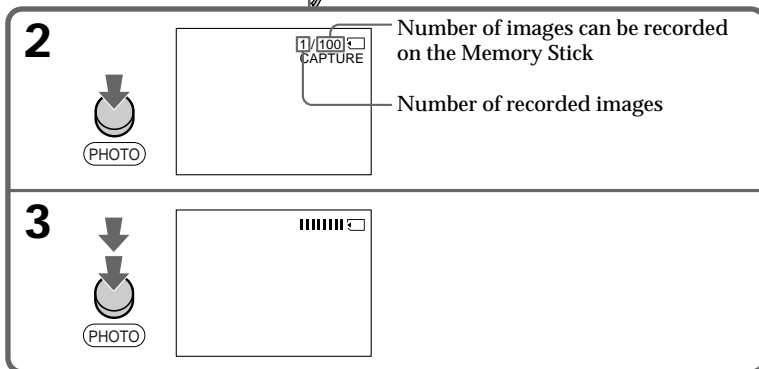
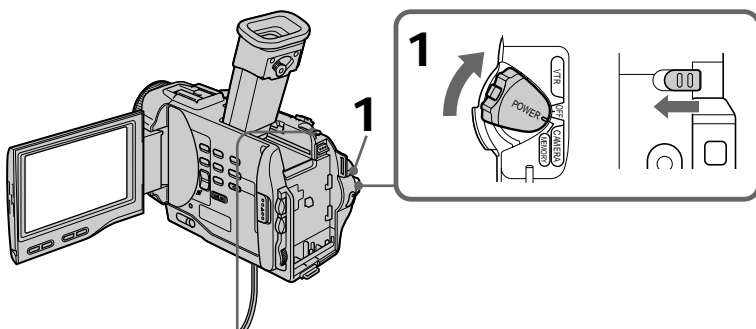

Notes

- When recording fast-moving subjects in the FRAME mode, the recorded image blurry.
- When recording in the FRAME mode, your camcorder may not correct camera-shake. We recommend that you shoot objects with a tripod.

When the POWER switch is set to MEMORY

The following functions do not work:

wide TV mode, digital effect, picture effect, title.

Recording still images on Memory Sticks – Memory photo recording

When you are recording a still image

You can neither turn off the power nor press PHOTO.

When you press the PHOTO button on the Remote Commander

Your camcorder immediately records the image that is on the screen when you press the button.

Recording images continuously

You can record still pictures continuously. Select one of the two modes described below before recording.

Continuous mode [a]

You can record 3 or 4 pictures continuously.

Multi screen mode [b]

You can record 9 still pictures continuously on a single page.

[a]



[b]



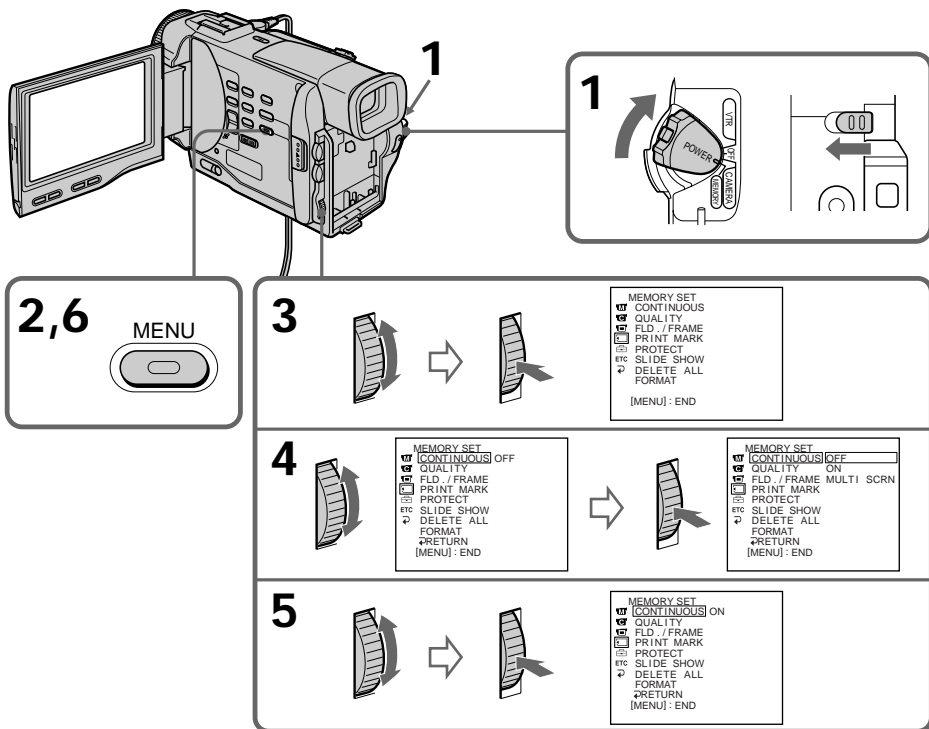

Recording still images on Memory Sticks – Memory photo recording

- (1) Set the POWER switch to MEMORY. Make sure that the lock is set to the left (unlock) position.
- (2) Press MENU to make the MENU display appear.
- (3) Turn the SEL/PUSH EXEC dial to select , then press the dial.
- (4) Turn the SEL/PUSH EXEC dial to select CONTINUOUS, then press the dial.
- (5) Turn the SEL/PUSH EXEC dial to select the desired setting, then press the dial.
- (6) Press MENU to erase the menu display.



Recording still images on Memory Sticks – Memory photo recording

Continuous shooting settings

Setting	Meaning (indicator on the screen)
OFF	Your camcorder shoots one image at a time. (no indicator)
ON	Your camcorder shoots 3 or 4 still images at about 0.8 sec intervals. ()
MULTI SCRN	Your camcorder shoots 9 still images at about 0.3 sec intervals and displays the images on a single page divided into 9 boxes. ()

Number of images in continuous shooting

The number of images you can shoot continuously varies depending on the image quality mode.

FINE: 3 images

STANDARD: 4 images

Note on using the video flash light (not supplied)

The video flash light does not work in the continuous or multi screen mode if you install it to the accessory shoe.

Recording an image from a mini DV tape as a still image

- DCR-TRV10 only

Your camcorder can read moving picture data recorded on a mini DV tape and record it as a still image on a Memory Stick. Your camcorder can also take in moving picture data through the input connector and record it as a still image on a Memory Stick.

Before operation

Insert a recorded mini DV tape and a Memory Stick into your camcorder.

- (1) Set the POWER switch to VTR.
- (2) Press **▶**. The picture recorded on the mini DV tape is played back.
- (3) Keep pressing PHOTO lightly until the picture from the mini DV tape freezes. "CAPTURE" appears on the LCD screen or in the viewfinder. Recording does not start yet.
- (4) Press PHOTO deeper. The image displayed on the screen will be recorded on a Memory Stick. Recording is complete when the bar scroll indicator disappears.

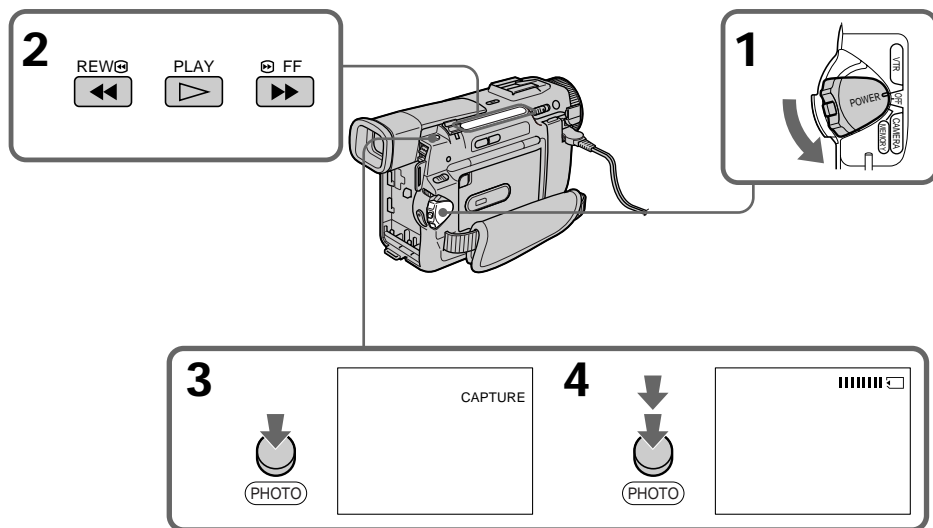

Memory Stick operations

When the ACCESS lamp is lit or flashing

Never shake or strike the unit. As well do not turn the power off, eject a Memory Stick or remove the battery pack. Otherwise, the image data breakdown may occur.

If "⊠" appears on the LCD screen or in the viewfinder

An incompatible Memory Stick is inserted. Be sure to use proper Memory Stick.

If you press PHOTO lightly in the playback mode

Your camcorder stops momentarily.

Sound recorded on a mini DV tape

You cannot record the audio from a mini DV tape.

Titles have already recorded on mini DV tapes

You cannot record the titles on Memory Sticks. The title does not appear while you are recording a still picture with PHOTO.

Recording an image from a mini DV tape as a still image

Recording a still image from other equipment

- (1) Set the POWER switch to VTR and set DISPLAY in **[ETC]** to LCD in the MENU settings.
- (2) Play back the recorded tape, or turn the TV on to see the desired program.
- (3) Follow the steps 3 and 4 on page 89.

When recording the image through the AUDIO/VIDEO jack

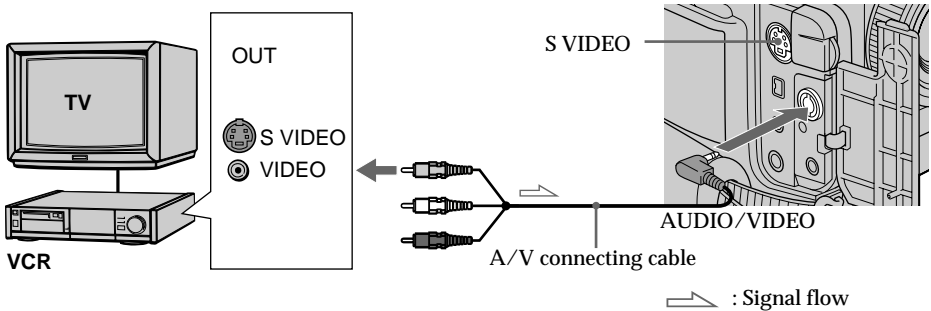

Connect the yellow plug of the A/V connecting cable to the video jack on the VCR or the TV.

When recording the image through the DV IN/OUT jack

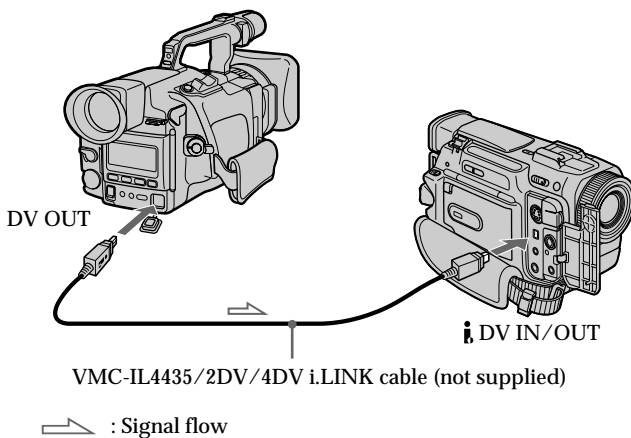

Connect using an S video cable (not supplied) to obtain high-quality pictures. With this connection, you do not need to connect the yellow (video) plug of the A/V connecting cable. Connect an S video cable (not supplied) to the S video jacks of both your camcorder and the VCR. This connection produces higher quality DV format pictures.

Copying still images from a mini DV tape – Photo save

To stop copying

Press MENU to stop copying.

When the memory of the Memory Stick is full

“MEMORY FULL” appears on the LCD screen, and the copying stops. Insert another Memory Stick and repeat the procedure from step 2.

When the ACCESS lamp is lit or flashing

Never shake or strike your camcorder. As well do not turn the power off, eject a Memory Stick or remove the battery pack. Otherwise, the image data breakdown may occur.

To record all the images recorded on the mini DV tape

Rewind the tape all the way back and start copying.

If the write-protect tab on the Memory Stick is set to LOCK

“NOT READY” appears when you select the item in the MENU settings.

When you change Memory Sticks in the middle of copying

Your comcorder resumes copying from the last image recorded on the previous Memory Stick.

Viewing a still picture – Memory photo playback

– DCR-TRV10 only

You can play back still images recorded on a Memory Stick. You can also play back 6 images at a time by selecting the index screen.

Before operation

Insert a Memory Stick into your camcorder.

- (1) Set the POWER switch to MEMORY or VTR. Make sure that the lock is set to the left (unlock) position.
- (2) Slide OPEN in the direction of the ► mark. Then, open the LCD panel.
- (3) Press MEMORY PLAY. The last recorded image is displayed.
- (4) Press MEMORY +/- to select the desired still image. To see the previous image, press MEMORY -. To see the next image, press MEMORY +.

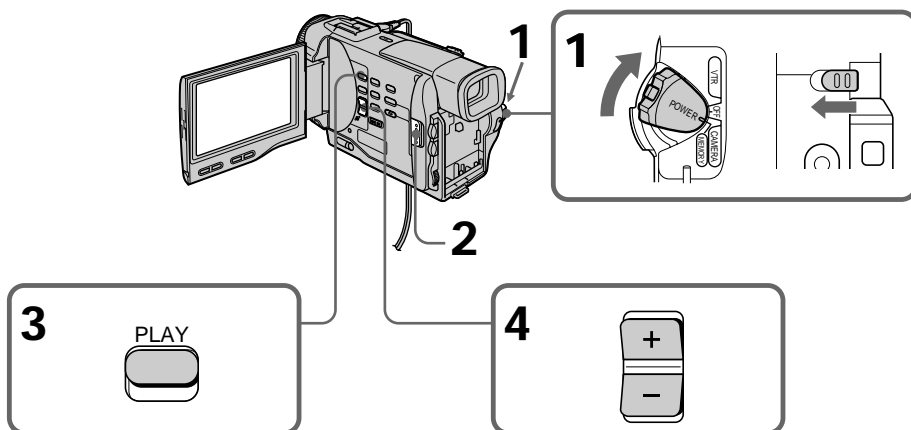

To stop memory photo playback

Press MEMORY PLAY again.

Viewing a still picture – Memory photo playback

To play back recorded images on a TV screen

- Connect your camcorder to the TV with the A/V connecting cable supplied with your camcorder before the operation.
- When operating memory photo playback on a TV or the LCD screen, the image quality may appear to have deteriorated. This is not a malfunction. The image data is as good as ever.
- Turn the audio volume of the TV down before operation, or noise (howling) may be output from the TV speakers.

Image data modified with personal computers or shot with other equipment

You may not be able to play them back with your camcorder.

Screen indicators during still image playback

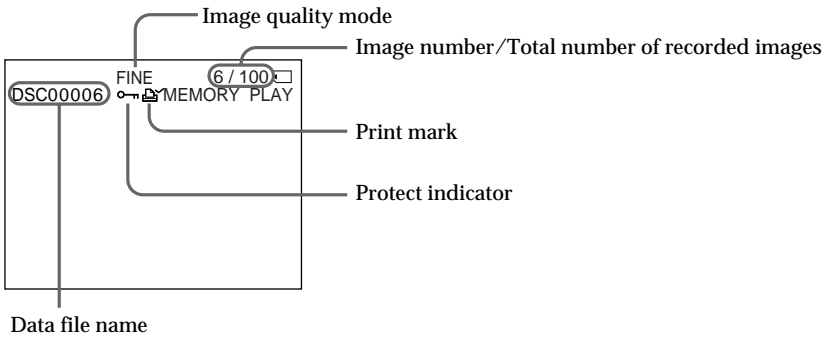

Playing back 6 recorded images at a time (index screen)

You can play back 6 recorded images at a time. This function is especially useful when searching for a particular image.

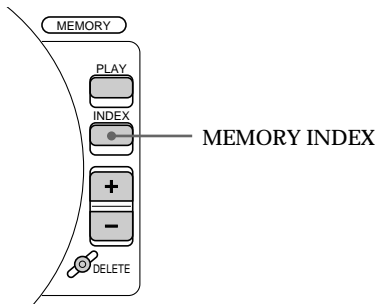

Press MEMORY INDEX.

A red ► mark appears above the image that is displayed before changing to the index screen mode.

Viewing a still picture – Memory photo playback

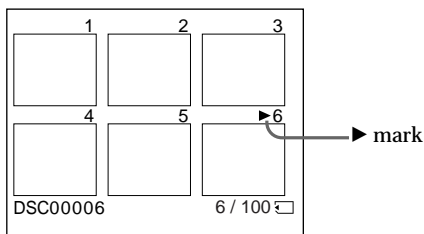

- To display the following 6 images, keep pressing MEMORY +.
- To display the previous 6 images, keep pressing MEMORY -.

To return to the normal playback screen (single screen)

Press MEMORY +/- to move the ► mark to the image you want to display on full screen, then press MEMORY PLAY.

Note

When displaying the index screen, the number appears above each image. This indicates the order in which images are recorded on the Memory Stick. These numbers are different from the data file names.

The image quality mode indicator

The indicator may show a mode different to the one in which you recorded. This is not a malfunction. The indicator shows the size of the data file. For instance, if the size of FINE image is small enough, it may be displayed as STD. Or if the size of image is large enough, it may be displayed as SFN.

Files modified with personal computers

These files may not be displayed on the index screen. Image files shot with other equipment may not be displayed on the index screen either.

Viewing a still picture – Memory photo playback

Viewing the recorded images using a personal computer

The image data recorded with your camcorder is compressed in the JPEG format. If you use the application software, "PictureGear 3.2Lite" supplied with your camcorder, you can see images recorded on a Memory Stick on a computer screen. Use the serial port adaptor for Memory Stick supplied with your camcorder, the MSAKIT-PC4A Memory Stick/PC card kit or MSAC-PC1 PC card adaptor for Memory Stick (not supplied) for this operation. For detailed instructions on operation, refer to the operating instructions of the serial port adaptor, Memory Stick/PC card kit or PC card adaptor and application software.

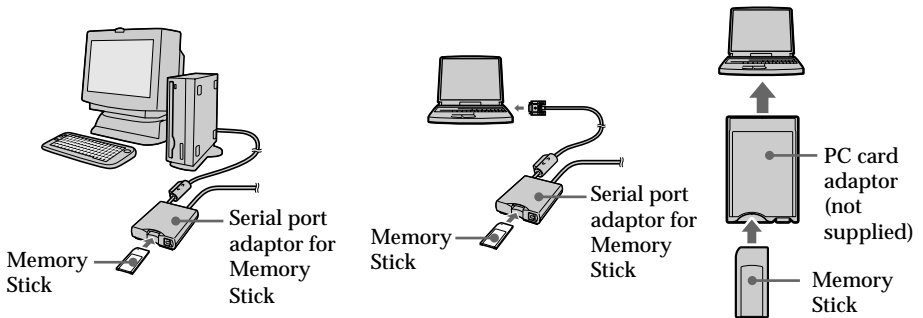

Superimposing a still picture in a Memory Stick on a moving picture

– M. CHROM/M. LUMI/C. CHROM

– DCR-TRV10 only

You can superimpose a still picture you have recorded on a Memory Stick on top of the moving picture you are recording.

M. CHROM (Memory chroma key)

You can swap a blue area of a still picture such as an illustration or a frame with a moving picture.

M. LUMI (Memory luminance key)

You can swap a brighter area of a still picture such as a handwritten illustration or title with a moving picture. Record a title on a Memory Stick before a trip or event for convenience.

C. CHROM (Camera chroma key)

You can superimpose a moving picture on top of a still picture such as a picture can be used as background. Shoot the subject against a blue background. The blue area of the moving picture will be swapped with a still picture.

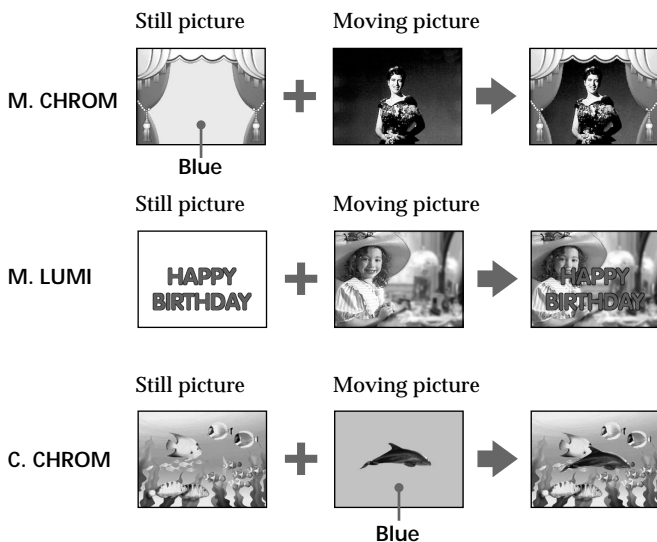

Superimposing a still picture in a Memory Stick on a moving picture - M. CHROM/M. LUMI/C. CHROM

Before operation

Insert a recorded Memory Stick on your camcorder.

- (1) Set the POWER switch to CAMERA.
- (2) Press MEMORY PLAY in the standby mode.
The last recorded or last composed image appears on the lower part of the screen as a thumbnail image.
- (3) Turn the SEL/PUSH EXEC dial to select the desired mode, then press the dial to set.
The mode changes as follows:
M. CHROM → M. LUMI → C. CHROM
- (4) Press the SEL/PUSH EXEC dial.
The still picture is superimposed on the moving picture.
- (5) Press MEMORY+/- to select the still picture you want to superimpose.
To see the previous image, press MEMORY -. To see the next image, press MEMORY+.
- (6) Turn the SEL/PUSH EXEC dial to adjust the effect.
- (7) Press START/STOP to start recording.

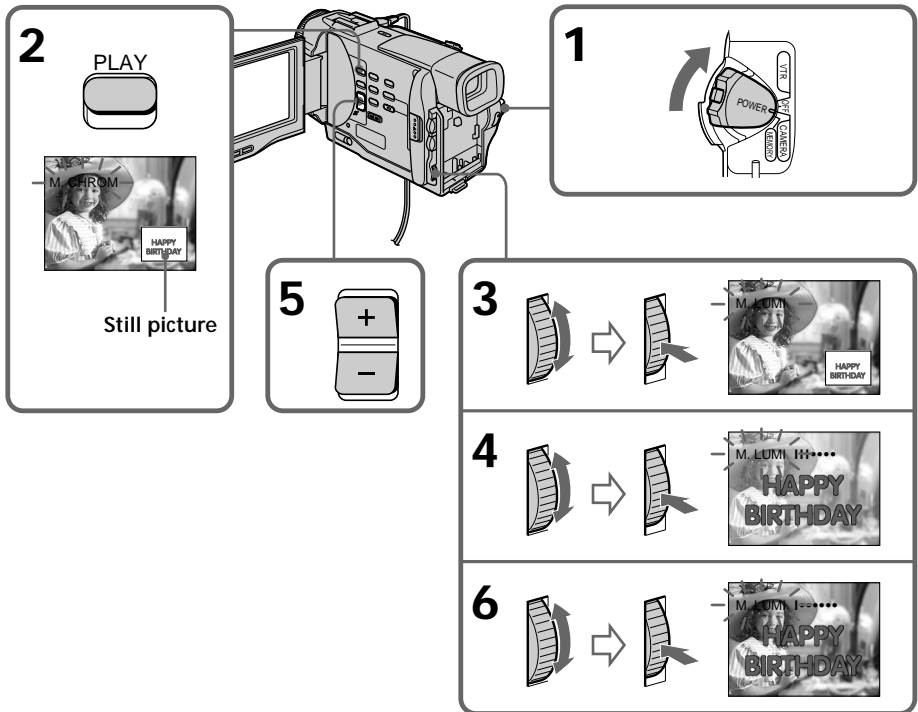

Superimposing a still picture in a Memory Stick on a moving picture - M. CHROM/M. LUMI/C. CHROM

Items to adjust

M. CHROM	The color (blue) scheme of the area in the still picture which is to be swapped with a moving picture
M. LUMI	The color (bright) scheme of the area in the still picture which is to be swapped with a moving picture
C. CHROM	The color (blue) scheme of the area in the moving picture which is to be swapped with a still picture

The fewer bars there are on the screen, the stronger the effect.

To change the still picture to superimpose

Do either of the following:

- Press MEMORY+/- before step 7.
- Press the SEL/PUSH EXEC dial before step 7, and repeat the procedure from step 3.

To change the mode setting

Press the SEL/PUSH EXEC dial before step 7, and repeat the procedure from step 3.

To cancel M. CHROM/M. LUMI/C. CHROM

Press MEMORY PLAY.

The Memory Stick supplied with your camcorder stores 30 images

- For M. CHROM: 26 images (such as a frame) DSC00001~DSC00026
- For C. CHROM: 4 images (such as a background) DSC00027~DSC00030

Sample images stored before leaving the factory

Sample images are protected (p. 100).

If you format the Memory Stick

Sample images will be deleted.

During recording

You cannot change the mode setting.

Preventing accidental erasure - Image protection

- DCR-TRV10 only

To prevent accidental erasure of important images, you can protect selected images.

Before operation

Insert a Memory Stick into your camcorder.

- (1) Play back the image you want to protect.
- (2) Press MENU to make the MENU display appear.
- (3) Turn the SEL/PUSH EXEC dial to select , then press the dial.
- (4) Turn the SEL/PUSH EXEC dial to select PROTECT, then press the dial.
- (5) Turn the SEL/PUSH EXEC dial to select ON, then press the dial.
- (6) Press MENU to erase the menu display. The "⏏" mark is displayed beside the data file name of the protected image.

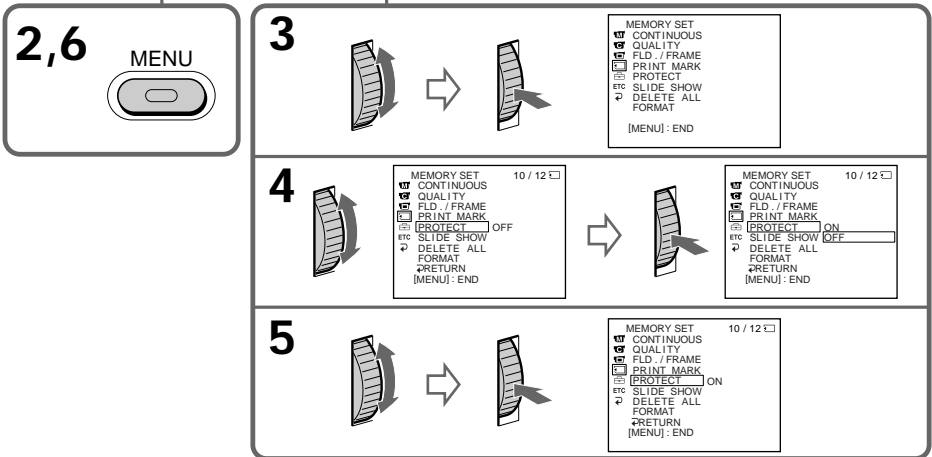
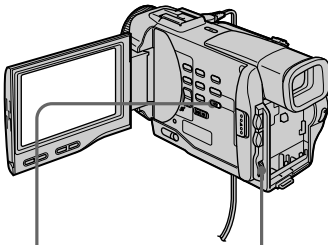

To cancel image protection

Select OFF in step 5, then press the SEL/PUSH EXEC dial.

Note

Formatting erases all information on the Memory Stick, including the protected image data. Check the contents of the Memory Stick before formatting.

If the write-protect tab on the Memory Stick is set to LOCK

You cannot carry out image protection.

Writing a print mark – PRINT MARK



– DCR-TRV10 only

You can specify the recorded still image to print out. This function is useful for printing out still images later.





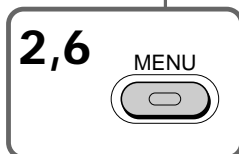
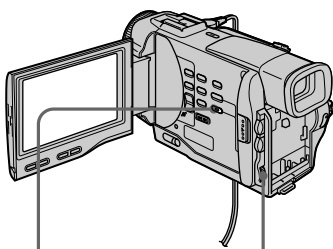

Your camcorder conforms with the DPOF (Digital Print Order Format) standard for specifying the still images to print out.

Before operation

Insert a Memory Stick into your camcorder.

- (1) Play back the image you want to write a print mark.
- (2) Press MENU to display the menu.
- (3) Turn the SEL/PUSH EXEC dial to select , then press the dial.
- (4) Turn the SEL/PUSH EXEC dial to select PRINT MARK, then press the dial.
- (5) Turn the SEL/PUSH EXEC dial to select ON, then press the dial.
- (6) Press MENU to erase the menu display. The “” mark is displayed beside the data file name of the image with a print mark.



3			<table border="1"><tr><td>MEMORY SET</td><td>10 / 12 □</td></tr><tr><td>CONTINUOUS</td><td>QUALITY</td></tr><tr><td>FLD./FRAME</td><td>PRINT MARK</td></tr><tr><td>PROTECT</td><td>SLIDE SHOW</td></tr><tr><td>ETC</td><td>DELETE ALL</td></tr><tr><td>FORMAT</td><td>RETURN</td></tr><tr><td>[MENU] : END</td><td></td></tr></table>	MEMORY SET	10 / 12 □	CONTINUOUS	QUALITY	FLD./FRAME	PRINT MARK	PROTECT	SLIDE SHOW	ETC	DELETE ALL	FORMAT	RETURN	[MENU] : END																	
MEMORY SET	10 / 12 □																																
CONTINUOUS	QUALITY																																
FLD./FRAME	PRINT MARK																																
PROTECT	SLIDE SHOW																																
ETC	DELETE ALL																																
FORMAT	RETURN																																
[MENU] : END																																	
4			<table border="1"><tr><td>MEMORY SET</td><td>10 / 12 □</td></tr><tr><td>CONTINUOUS</td><td>QUALITY</td></tr><tr><td>FLD./FRAME</td><td>PRINT MARK OFF</td></tr><tr><td>PROTECT</td><td>SLIDE SHOW</td></tr><tr><td>ETC</td><td>DELETE ALL</td></tr><tr><td>FORMAT</td><td>RETURN</td></tr><tr><td>[MENU] : END</td><td></td></tr></table>	MEMORY SET	10 / 12 □	CONTINUOUS	QUALITY	FLD./FRAME	PRINT MARK OFF	PROTECT	SLIDE SHOW	ETC	DELETE ALL	FORMAT	RETURN	[MENU] : END			<table border="1"><tr><td>MEMORY SET</td><td>10 / 12 □</td></tr><tr><td>CONTINUOUS</td><td>QUALITY</td></tr><tr><td>FLD./FRAME</td><td>PRINT MARK ON</td></tr><tr><td>PROTECT</td><td>SLIDE SHOW OFF</td></tr><tr><td>ETC</td><td>DELETE ALL</td></tr><tr><td>FORMAT</td><td>RETURN</td></tr><tr><td>[MENU] : END</td><td></td></tr></table>	MEMORY SET	10 / 12 □	CONTINUOUS	QUALITY	FLD./FRAME	PRINT MARK ON	PROTECT	SLIDE SHOW OFF	ETC	DELETE ALL	FORMAT	RETURN	[MENU] : END	
MEMORY SET	10 / 12 □																																
CONTINUOUS	QUALITY																																
FLD./FRAME	PRINT MARK OFF																																
PROTECT	SLIDE SHOW																																
ETC	DELETE ALL																																
FORMAT	RETURN																																
[MENU] : END																																	
MEMORY SET	10 / 12 □																																
CONTINUOUS	QUALITY																																
FLD./FRAME	PRINT MARK ON																																
PROTECT	SLIDE SHOW OFF																																
ETC	DELETE ALL																																
FORMAT	RETURN																																
[MENU] : END																																	
5			<table border="1"><tr><td>MEMORY SET</td><td>10 / 12 □</td></tr><tr><td>CONTINUOUS</td><td>QUALITY</td></tr><tr><td>FLD./FRAME</td><td>PRINT MARK ON</td></tr><tr><td>PROTECT</td><td>SLIDE SHOW</td></tr><tr><td>ETC</td><td>DELETE ALL</td></tr><tr><td>FORMAT</td><td>RETURN</td></tr><tr><td>[MENU] : END</td><td></td></tr></table>	MEMORY SET	10 / 12 □	CONTINUOUS	QUALITY	FLD./FRAME	PRINT MARK ON	PROTECT	SLIDE SHOW	ETC	DELETE ALL	FORMAT	RETURN	[MENU] : END																	
MEMORY SET	10 / 12 □																																
CONTINUOUS	QUALITY																																
FLD./FRAME	PRINT MARK ON																																
PROTECT	SLIDE SHOW																																
ETC	DELETE ALL																																
FORMAT	RETURN																																
[MENU] : END																																	

To cancel writing print marks

Select OFF in step 5, then press the SEL/PUSH EXEC dial.

If the write-protect tab on the Memory Stick is set to LOCK
You cannot write print marks on still images.

Deleting images

– DCR-TRV10 only

Deleting selected images

Before operation

Insert a Memory Stick into your camcorder.

- (1) Play back the image you want to delete.
- (2) Press MEMORY DELETE with a sharp-pointed object. “DELETE?” appears on the LCD screen.
- (3) Press MEMORY DELETE again. The selected image is deleted.



To cancel deleting an image

Press MEMORY – in step 3.

To delete an image displayed on the index screen

Press MEMORY +/- to move the ► indicator to the desired image and follow steps 2 and 3.

Notes

- To delete a protected image, first cancel image protection.
- Once you delete an image, you cannot restore it. Check the images to delete carefully before deleting them.

Deleting all the images

You can delete all the unprotected images in a Memory Stick.

Deleting images

Before operation

Insert a Memory Stick into your camcorder.

- (1) Set the POWER switch to MEMORY. Make sure that the lock is set to the left (unlock) position.
- (2) Press MENU to make the MENU display appear.
- (3) Turn the SEL/PUSH EXEC dial to select \square , then press the dial.
- (4) Turn the SEL/PUSH EXEC dial to select DELETE ALL, then press the dial.
- (5) Turn the SEL/PUSH EXEC dial to select OK, then press the dial. "OK" changes to "EXECUTE."
- (6) Turn the SEL/PUSH EXEC dial to select EXECUTE, then press the dial. "DELETING" appears on the LCD screen. When all the unprotected images are deleted, "COMPLETE" is displayed.

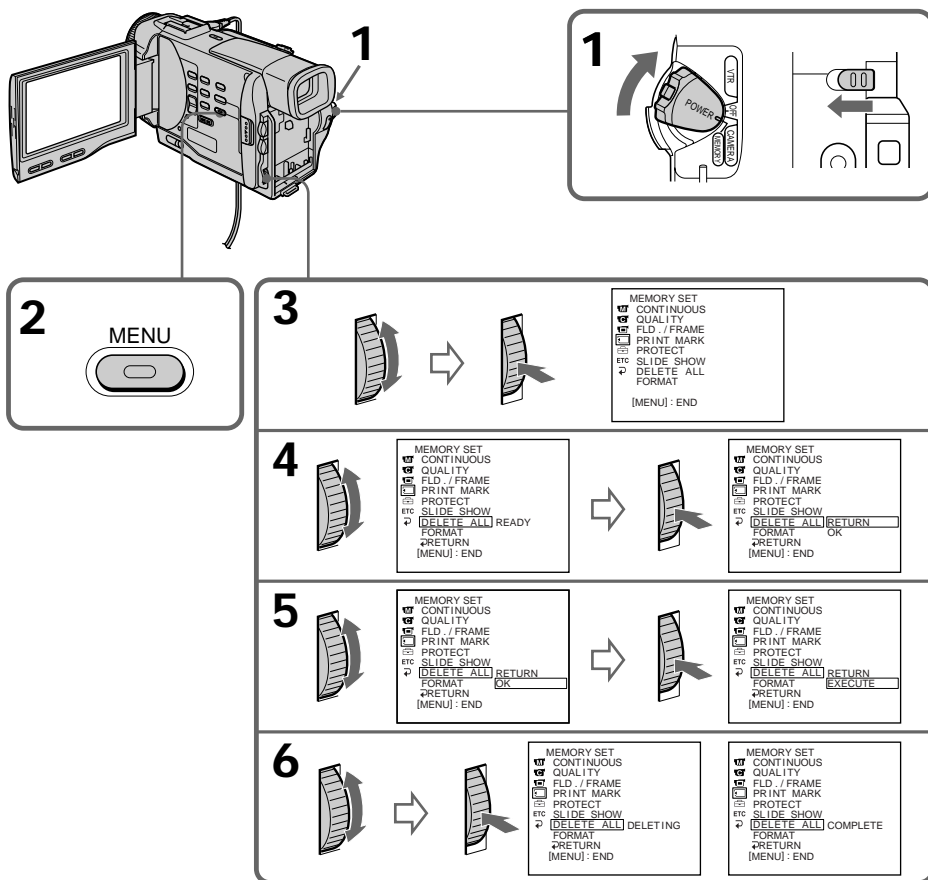

Deleting images

To cancel deleting all the images in the Memory Stick

Select ↵ RETURN in step 4, then press the SEL/PUSH EXEC.

While "DELETING" appears

Do not turn the POWER switch or press any buttons.

If the write-protect tab on the Memory Stick is set to LOCK

You cannot delete images.

Copying the image recorded on Memory Sticks to mini DV tapes

- DCR-TRV10 only

You can copy still images or titles recorded on Memory Stick and record them to a mini DV tape.

Before operation

Insert a mini DV tape for recording and a Memory Stick into your camcorder.

- (1) Set the POWER switch to VTR.
- (2) Using the video control buttons, search a point where you want to record the desired still image. Set the mini DV tape to playback pause mode.
- (3) Press ● REC and the button on its right simultaneously on your camcorder. The mini DV tape is set to the recording pause mode.
- (4) Press MEMORY PLAY to play back the still image you want to copy.
- (5) Press ■ to start recording and press ■ again to stop.
- (6) If you have more to copy, repeat steps 4 and 5.

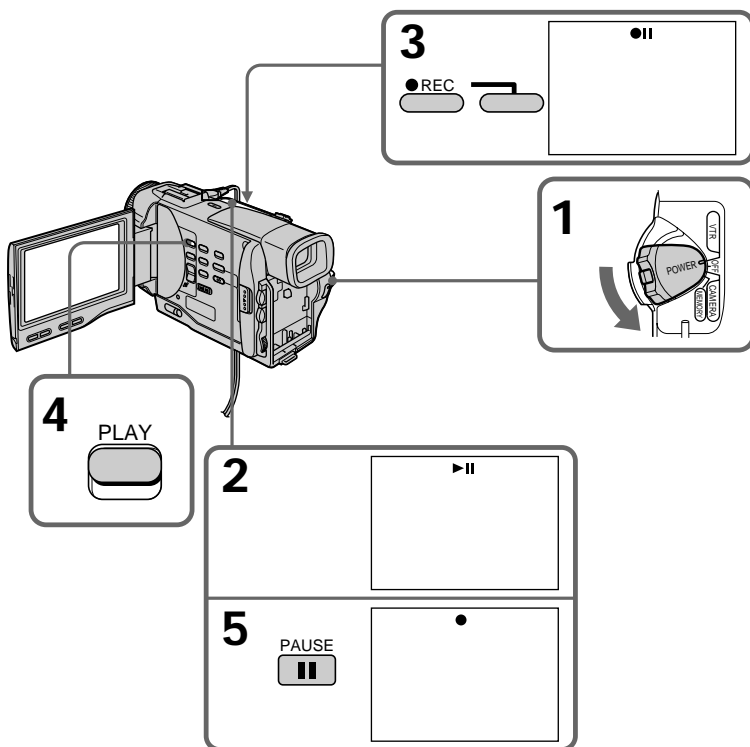

To stop copying in the middle

Press ■

During copying

You cannot operate the following buttons:

MEMORY PLAY, MEMORY INDEX, MEMORY DELETE, MEMORY +, and MEMORY -.

Copying the image recorded on Memory Sticks to mini DV tapes

Note on the index screen

You cannot record the index screen.

If you press the EDITSEARCH buttons during pause mode

Memory playback stops.

Image data modified with personal computers or shot with other equipment

You may not be able to copy them with your camcorder.

If you press the DISPLAY button in the standby or recording mode

You can see memory playback and the file name indicators in addition to the indicators pertinent to mini DV tapes, such as the time code indicator.

Playing back images in a continuous loop – SLIDE SHOW

– DCR-TRV10 only

You can automatically play back images in sequence. This function is useful especially when checking recorded images or during a presentation.

Before operation

Insert a Memory Stick into your camcorder.

- (1) Set the POWER switch to MEMORY. Make sure that the lock is set to the left (unlock) position.
- (2) Press MENU to make the MENU display appear.
- (3) Turn the SEL/PUSH EXEC dial to select , then press the dial.
- (4) Turn the SEL/PUSH EXEC dial to select SLIDE SHOW, then press the dial.
- (5) Press MEMORY PLAY. Your camcorder plays back the images recorded on a Memory Stick in sequence.

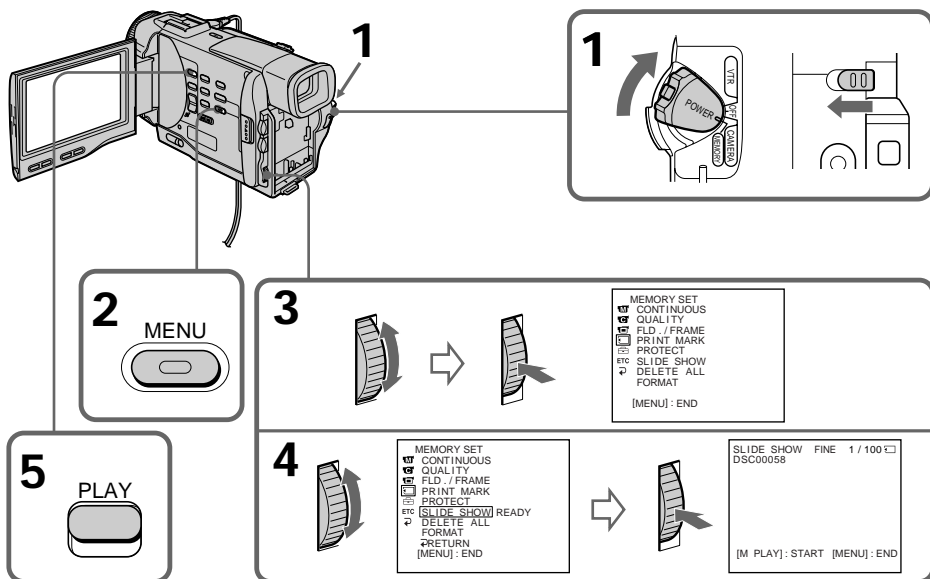

To stop the slide show

Press MENU.

To pause during a slide show

Press MEMORY PLAY.

To start the slide show from a particular image

Select the desired image using MEMORY +/- buttons before step 2.

Playing back images in a continuous loop – SLIDE SHOW

To view the recorded images on TV

Connect your camcorder to a TV with the A/V connecting cable supplied with your camcorder before operation.

If you change the Memory Stick during operation

The slide show does not operate. If you change the Memory Stick, be sure to follow the steps again from the beginning.

Usable cassettes

Selecting cassette types

You can use the **mini DV** mini DV cassette only*. You cannot use any other **8 mm**, **Hi8** Hi8, **Digital8** Digital8, **VHS** VHS, **VHS-C** VHSC, **S-VHS** S-VHS, **S-VHS-C** S-VHSC, **B** Betamax, **ED Beta** ED Betamax or **DV** DV cassette.

* There are two types of mini DV cassettes: with cassette memory and without cassette memory. We recommend you to use the tape with cassette memory.

The IC memory is mounted on this type of mini DV cassette. Your camcorder can read and write data such as dates of recording or titles, etc. to this memory.

The functions using the cassette memory require successive signals recorded on the tape. If the tape has a blank portion in the beginning or between the recorded portions, a title may not be displayed properly or the search functions may not work properly. Not to make any blank portion on the tape, operate the followings.

Press END SEARCH to go to the end of the recorded portion before you begin the next recording if you operate the followings:

- you have ejected the cassette while recording.
- you have played back the tape in the VTR mode.
- you have used the edit search function.

If there is a blank portion or discontinuous signal on your tape, re-record from the beginning to the end of the tape concerning above.

The same result may occur when you record using a digital video camera recorder without a cassette memory function on a tape recorded by one with the cassette memory function.

Tapes with cassette memory have **CIII** (Cassette Memory) mark. Sony recommends that you use a tape having **CIII** mark to enjoy your camcorder fully.

CIII4K mark on the cassette

The memory capacity of tapes marked with **CIII4K** is 4KB. Your camcorder can accommodate tapes having a memory capacity of up to 16KB. 16KB tape is marked with **CIII16K**.

When you play back

Copyright signal

When playing back

Using any other video camera recorder, you cannot record on a tape that has recorded a copyright control signals for copyright protection of software which is played back on your camcorder.

When you record

You cannot record software on your camcorder that contains copyright control signals for copyright protection of software.

"COPY INHIBIT" appears on the LCD screen, in the viewfinder or on the TV screen if you try to record such software.

Your camcorder does not record copyright control signals on the tape when it records.

Usable cassettes

Audio mode

12-bit mode: The original sound can be recorded in stereo 1, and the new sound in stereo 2 in 32 kHz. The balance between stereo 1 and stereo 2 can be adjusted by selecting AUDIO MIX in the MENU settings during playback. Both sounds can be played back.

16-bit mode: A new sound cannot be recorded but the original sound can be recorded in high quality. Moreover, it can also play back sound recorded in 32 kHz, 44.1 kHz or 48 kHz. When playing back a tape recorded in the 16-bit mode, 16BIT indicator appears on the LCD screen or in the viewfinder.

When you play back a dual sound track tape

When you play back a dual sound track tape recorded in a stereo system, set “HiFi SOUND” to the desired mode in the MENU settings (p. 72).

Sound from speaker

HiFi Sound Mode	Playing back a stereo tape	Playing back a dual sound track tape
STEREO	Stereo	Main sound and sub sound
1	Left sound	Main sound
2	Right sound	Sub sound

You cannot record dual sound programs on your camcorder.

Notes on the mini DV cassette

When affixing a label on the mini DV cassette

Be sure to affix a label only on the locations as illustrated below [a] so as not to cause malfunction of your camcorder.

After using the mini DV cassette

Rewind the tape to the beginning, put the cassette in its case, and store it in an upright position.

Cleaning gold-plated connector

If the gold-plated connector of mini DV cassettes is dirty or dusty, you may not operate the function using cassette memory. Clean up the gold-plated connector with cotton-wool swab, about every 10 times ejection of a cassette. [b]

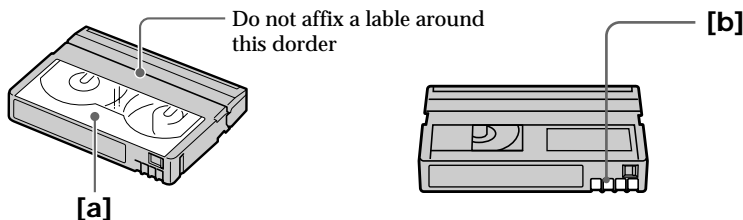

Troubleshooting

If you run into any problem using your camcorder, use the following table to troubleshoot the problem. If the problem persists, disconnect the power source and contact your Sony dealer or local authorized Sony service facility. If "C:□□:□□" appears on the LCD screen or in the viewfinder, the self-diagnosis display function has worked. See page 116.

In the recording mode

Symptom	Cause and/or Corrective Actions
START/STOP does not operate.	<ul style="list-style-type: none">• The POWER switch is set to VTR. → Set it to CAMERA. (p. 15)• The POWER switch is set to OFF. → Set the POWER switch to CAMERA. (p. 15)• The tape has run out. → Rewind the tape or insert a new one. (p. 14, 25)• The write-protect tab is set to expose the red mark. → Use a new tape or slide the tab. (p. 14)• The tape is stuck to the drum (moisture condensation). → Remove the cassette and leave your camcorder for at least 1 hour to acclimatize. (p. 120)
Recording stops in a few seconds.	<ul style="list-style-type: none">• START/STOP MODE is set to 5SEC or $\frac{1}{2}$. → Set it to $\frac{1}{4}$. (p. 20)
The power goes off.	<ul style="list-style-type: none">• While being operated in the CAMERA mode, your camcorder has been in the standby mode for more than 5 minutes. → Set the POWER switch to OFF and then to CAMERA again. (p. 15)
The image on the viewfinder screen is not clear.	<ul style="list-style-type: none">• The viewfinder lens is not adjusted. → Adjust the viewfinder lens. (p. 18)
The SteadyShot function does not work.	<ul style="list-style-type: none">• STEADYSHOT is set to OFF in the MENU settings. → Set it to ON. (p. 72)
The autofocus function does not work.	<ul style="list-style-type: none">• FOCUS is set to MANUAL. → Set it to AUTO. (p. 45)• Shooting conditions are not suitable for autofocus. → Set FOCUS to MANUAL to focus manually. (p. 45)
The fader function does not work.	<ul style="list-style-type: none">• START/STOP MODE is set to 5SEC or $\frac{1}{2}$. → Set it to $\frac{1}{4}$. (p. 20)• The digital effect function is working. → Cancel it. (p. 39)
The \otimes indicator flashes in the viewfinder or on the LCD screen.	<ul style="list-style-type: none">• The video heads may be dirty. → Clean the heads using the Sony DVM12CL cleaning cassette (not supplied). (p. 121)
The picture does not appear in the viewfinder.	<ul style="list-style-type: none">• The LCD panel is open. → Close the LCD panel. (p. 17)

(continued on the following page)

Troubleshooting

Symptom	Cause and/or Corrective Actions
A vertical band appears when you shoot a subject such as lights or a candle flame against a dark background.	<ul style="list-style-type: none"> The contrast between the subject and background is too high. Your camcorder is not a malfunction.
A vertical band appears when you shoot a very bright subject.	<ul style="list-style-type: none"> Your camcorder is not a malfunction.
Some tiny white spots appear in the viewfinder or on the LCD screen.	<ul style="list-style-type: none"> Slow shutter, low lux or NightShot +Slow shutter mode is activated. This is not a malfunction.
An unknown picture is displayed in the viewfinder or on the LCD screen.	<ul style="list-style-type: none"> If 10 minutes elapse after you set the POWER switch to CAMERA or DEMO MODE is set to ON in the MENU settings without a cassette inserted, your camcorder automatically starts the demonstration. <ul style="list-style-type: none"> → Insert a cassette and the demonstration stops. You can also cancel DEMO MODE. (p. 77)
The picture is recorded in incorrect or unnatural colors.	<ul style="list-style-type: none"> NIGHTSHOT is set to ON. <ul style="list-style-type: none"> → Set it to OFF. (p. 21)
Picture appears too bright, and the subject does not appear in the viewfinder or on the LCD screen.	<ul style="list-style-type: none"> NIGHTSHOT is set to ON in a bright place. <ul style="list-style-type: none"> → Set it to OFF, or use the NightShot function in a dark place. (p. 21)
The click of the shutter does not sound.	<ul style="list-style-type: none"> BEEP is set to OFF in the MENU settings. <ul style="list-style-type: none"> → Set it to MELODY or NORMAL. (p. 72)





In the playback mode

Symptom	Cause and/or Corrective Actions
The tape does not move when a video control button is pressed.	<ul style="list-style-type: none"> The POWER switch is set to CAMERA or OFF. <ul style="list-style-type: none"> → Set it to VTR. (p. 25) The tape has run out. <ul style="list-style-type: none"> → Rewind the tape. (p. 25)
The playback picture is not clear or does not appear.	<ul style="list-style-type: none"> The television's video channel is not adjusted correctly. <ul style="list-style-type: none"> → Adjust it. (p. 28)
There are nine horizontal lines on the picture or the playback picture is not clear or does not appear.	<ul style="list-style-type: none"> The video head may be dirty. <ul style="list-style-type: none"> → Clean the heads using the Sony DVM12CL cleaning cassette (not supplied). (p. 121)
No sound or only a low sound is heard when playing back a tape.	<ul style="list-style-type: none"> The volume is turned to minimum. <ul style="list-style-type: none"> → Open the LCD panel and press VOLUME +. (p. 25) AUDIO MIX is set to ST2 in the MENU settings. <ul style="list-style-type: none"> → Adjust AUDIO MIX. (p. 72)
Displaying the recorded date, date search function does not work.	<ul style="list-style-type: none"> The tape has no cassette memory. <ul style="list-style-type: none"> → Use a tape with cassette memory. (p. 49, 109) CM SEARCH is set to OFF in the MENU settings. <ul style="list-style-type: none"> → Set it to ON. (p. 72)
The title search function does not work.	<ul style="list-style-type: none"> The tape has no cassette memory. <ul style="list-style-type: none"> → Use a tape with cassette memory. (p. 109) CM SEARCH is set to OFF in the MENU settings. <ul style="list-style-type: none"> → Set it to ON. (p. 72) There is no title in the tape. <ul style="list-style-type: none"> → Superimpose the titles. (p. 65)

Troubleshooting

Symptom	Cause and/or Corrective Actions
The new sound added to the recorded tape is not heard.	<ul style="list-style-type: none"> AUDIO MIX is set to ST1 side in the MENU settings. → Adjust AUDIO MIX in the MENU settings. (p. 72)
The title is not displayed.	<ul style="list-style-type: none"> TITLE DSPL is set to OFF in the MENU settings. → Set it to ON in the MENU settings. (p. 72)
The date search or title search does not work correctly.	<ul style="list-style-type: none"> The tape has a blank portion in the recorded portion (p. 109)

In the recording and playback modes

Symptom	Cause and/or Corrective Actions
The power does not turn on.	<ul style="list-style-type: none"> The battery pack is not installed, or is dead or nearly dead. → Install a charged battery pack. (p. 9, 10) The AC power adaptor is not connected to a wall outlet. → Connect the AC power adaptor to a wall outlet. (p. 13)
The end search function does not work.	<ul style="list-style-type: none"> The tape was ejected after recording when using a tape without cassette memory. You have not recorded on the new cassette yet.
The end search function does not work correctly.	<ul style="list-style-type: none"> The tape has a blank portion in the beginning or middle.
The battery pack is quickly discharged.	<ul style="list-style-type: none"> The operating temperature is too low. The battery pack is not fully charged. → Charge the battery pack again. (p. 10) The battery pack is completely dead, and cannot be recharged. → Replace with a new battery pack. (p. 9)
The battery remaining indicator does not indicate the correct time.	<ul style="list-style-type: none"> You have used the battery pack in an extremely hot or cold environment for a long time. The battery pack is completely dead, and cannot be recharged. → Replace with a new battery pack. (p. 9) The battery is dead. → Use a charged battery pack. (p. 9, 10)
The cassette cannot be removed from the holder.	<ul style="list-style-type: none"> The power source is disconnected. → Connect it firmly. (p. 9, 13) The battery is dead. → Use a charged battery pack or the AC power adaptor. (p. 9, 13)
The  and  indicators flash and no functions except for cassette ejection work.	<ul style="list-style-type: none"> Moisture condensation has occurred. → Remove the cassette and leave your camcorder for at least 1 hour to acclimatize. (p. 120)
 indicator does not appear when using a tape with cassette memory.	<ul style="list-style-type: none"> The gold-plated connector of the tape is dirty or dusty. → Clean the gold-plated connector. (p. 110)
Remaining tape indicator is not displayed.	<ul style="list-style-type: none"> The  REMAIN is set to AUTO in the MENU settings. → Set it to ON to always display the remaining tape indicator. (p. 72)

(continued on the following page)

Troubleshooting

When operating using the Memory Stick

– DCR-TRV10 only

Symptom	Cause and/or Corrective Actions
The Memory Stick does not function.	<ul style="list-style-type: none">• The POWER switch is set to CAMERA. → Set it to MEMORY. (p. 82)
Recording does not function.	<ul style="list-style-type: none">• The Memory Stick has already been recorded to its full capacity. → Erase unnecessary images and record again. (p. 102, 85)• The Memory Stick is not inserted. → Insert a Memory Stick. (p. 81)• Unformatted Memory Stick is inserted. → Format the Memory Stick. (p. 84)• The write-protect tab on the Memory Stick is set to LOCK. → Slide the tab to write. (p. 79)
The image cannot be deleted.	<ul style="list-style-type: none">• The image is protected. → Cancel image protection. (p. 100)
You cannot format the Memory Stick.	<ul style="list-style-type: none">• The write-protect tab on the Memory Stick is set to LOCK. → Set the tab to write. (p. 79)• Memory Stick is not inserted. → Insert a Memory Stick. (p. 81)
Deleting all the images cannot be carried out.	<ul style="list-style-type: none">• The write-protect tab on the Memory Stick is set to LOCK. → Set the tab to write. (p. 79)• Memory Stick is not inserted. → Insert a Memory Stick. (p. 81)
You cannot protect the image.	<ul style="list-style-type: none">• The write-protect tab on the Memory Stick is set to LOCK. → Set the tab to write. (p. 79)• The image to protect is not be played back. → Press MEMORY PLAY to play back the image. (p. 93)• Memory Stick is not inserted. → Insert a Memory Stick. (p. 81)
You cannot write a print mark on the still image.	<ul style="list-style-type: none">• The write-protect tab on the Memory Stick is set to LOCK. → Set the tab to write. (p. 79)• The image to write a print mark is not be played back. → Press MEMORY PLAY to play back the image. (p. 93)• Memory Stick is not inserted. → Insert a Memory Stick. (p. 81)
The slide show function does not work.	<ul style="list-style-type: none">• Memory Stick is not inserted. → Insert a Memory Stick. (p. 81)
The photo save function does not work.	<ul style="list-style-type: none">• The write-protect tab on the Memory Stick is set to LOCK. → Set the tab to write. (p. 79)• Memory Stick is not inserted. → Insert a Memory Stick. (p. 81)

Others

Symptom	Cause and/or Corrective Actions
The title is not recorded.	<ul style="list-style-type: none">• The tape has no cassette memory. → Use a tape with cassette memory. (p. 109)• The cassette memory is full. → Erase another title. (p. 67)• The tape is set to prevent accidental erasure. → Slide the write-protect tab so that red portion is not visible. (p. 14)• Nothing is recorded in that position on the tape. → Superimpose the title to the recorded position. (p. 65)

Troubleshooting

Symptom	Cause and/or Corrective Actions
The cassette label is not recorded.	<ul style="list-style-type: none"> • The tape has no cassette memory. → Use a tape with cassette memory. (p. 109) • The cassette memory is full. → Erase some titles. (p. 67) • The tape is set to prevent accidental erasure. → Slide the write-protect tab so that red portion is not visible. (p. 14)
While editing using the i.LINK cable (DV connecting cable), recording picture cannot be monitored.	<ul style="list-style-type: none"> • Remove the i.LINK cable (DV connecting cable), and connect it again.
DV synchro-editing does not function. (DCR-TRV10 only)	<ul style="list-style-type: none"> • The input selector on the VCR is not set correctly. → Set the selector to DV input position. If you use another DV camcorder, set the power switch to VTR. • The camcorder is connected to DV equipment of other than Sony. → Operate normal editing. • Setting program on a blank portion of the tape is attempted. → Set the program again on a recorded portion.
The picture from a TV or VCR does not appear even when your camcorder is connected to outputs on the TV or VCR.	<ul style="list-style-type: none"> • DISPLAY is set to V-OUT/LCD in the MENU settings. → Set it to LCD. (p. 72)
The Remote Commander supplied with your camcorder does not work.	<ul style="list-style-type: none"> • COMMANDER is set to OFF in the MENU settings. → Set it to ON. (p. 72) • Something is blocking the infrared rays. → Remove the obstacle. • The batteries are inserted in the battery holder with the + - polarities incorrectly matching the + - marks. → Insert the batteries with the correct polarity. (p. 132) • The batteries are dead. → Insert new ones. (p. 132)
The melody or beep sounds for 5 seconds.	<ul style="list-style-type: none"> • Moisture condensation has occurred. → Remove the cassette and leave your camcorder for at least 1 hour to acclimatize. (p. 120) • Some troubles has occurred in your camcorder. → Remove the cassette and insert it again, then operate your camcorder.
While charging the battery pack, no indicator appears or the indicator flashes in the display window.	<ul style="list-style-type: none"> • The AC power adaptor is disconnected. → Connect it firmly. (p. 13) • Something is wrong with the battery pack. → Contact your Sony dealer or local authorized Sony service facility.
No function works though the power is on.	<ul style="list-style-type: none"> • Disconnect the power cord of the AC power adaptor or remove the battery, then reconnect it in about 1 minute. Turn the power on. If the functions still do not work, open the LCD panel and press the RESET button beside the speaker using a sharp-pointed object. (If you press the RESET button, all the settings including the date and time return to the default.) (p. 127)

Self-diagnosis display

Your camcorder has a self-diagnosis display function.

This function displays the current condition of your camcorder as a 5-digit code (a combination of a letter and figures) in the viewfinder, on the LCD screen or in the display window. If a 5-digit code is displayed, check the following code chart. The last two digits (indicated by □□) will differ depending on the state of your camcorder.

Viewfinder (or LCD screen)

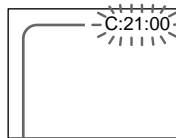

Self-diagnosis display

- C:□□:□□
You can service your camcorder yourself.
- E:□□:□□
Contact your Sony dealer or local authorized Sony facility.

Five-digit display	Cause and/or Corrective Actions
C:04:□□	<ul style="list-style-type: none"> • You are using a battery pack that is not an "InfoLITHIUM" battery pack. → Use an "InfoLITHIUM" battery pack. (p. 12)
C:21:□□	<ul style="list-style-type: none"> • Moisture condensation has occurred. → Remove the cassette and leave your camcorder for at least 1 hour to acclimatize. (p. 120)
C:22:□□	<ul style="list-style-type: none"> • The video heads are dirty. → Clean the heads using the Sony DVM12CL cleaning cassette (not supplied). (p. 121)
C:31:□□ C:32:□□	<ul style="list-style-type: none"> • A malfunction other than the above that you can service has occurred. → Remove the cassette and insert it again, then operate your camcorder. → Disconnect the power cord of the AC power adaptor or remove the battery pack. After reconnecting the power source, operate your camcorder.
E:61:□□ E:62:□□	<ul style="list-style-type: none"> • A malfunction that you cannot service has occurred. → Contact your Sony dealer or local authorized Sony service facility and inform them of the 5-digit code. (example: E:61:10)

If you are unable to rectify the problem even if you try corrective actions a few times, contact your Sony dealer or local authorized Sony service facility.

Warning indicators and messages

If indicators and messages appear in the viewfinder, on the LCD screen or in the display window, check the following:

See the page in parentheses “()” for more information.

- The warning messages do not appear in the mirror mode.
- The indicators and messages are displayed in yellow.

Warning indicators

The video heads are dirty

Slow flashing:

- You need to clean the heads using the Sony DVM12CL cleaning cassette (not supplied) (p. 121).

The battery is dead or nearly dead

Slow flashing:

- The battery is nearly dead.

Fast flashing:

- The battery is dead (p. 10).

Depending on conditions, the  indicator may flash, even if there are 5 to 10 minutes remaining.

Warning indicator as to tape

Slow flashing:

- The tape is near the end.
- No tape is inserted (p. 14).*

Fast flashing:

- The tape has run out (p. 14, 25).*
- The write-protect tab on the cassette is out (red) (p. 14).*

You need to eject the cassette

Slow flashing:

- The write-protect tab on the cassette is out (red) (p. 14).*

Fast flashing:

- Moisture condensation has occurred (p. 120).
- The tape has run out (p. 14, 25).*
- The self-diagnosis display function is activated (p. 116).*

Moisture condensation has occurred*
Fast flashing:

- Eject the cassette, turn off your camcorder, and leave it for about 1 hour with the cassette compartment open (p. 120).

Warning indicator as to cassette memory

Slow flashing:

- No tape with cassette memory is inserted (p. 14).*

Self-diagnosis display (p. 116)

Warning indicator as to Memory Stick (DCR-TRV10 only)

Slow flashing:

- No Memory Stick is inserted (p. 81).*
- Memory Stick is not formatted correctly (p. 84).

The still image is protected (DCR-TRV10 only)





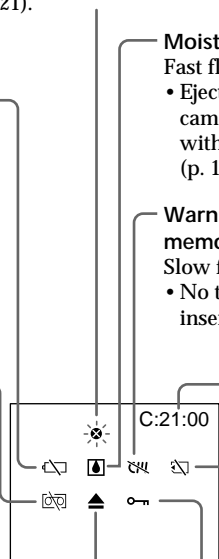





Slow flashing:

- The still image is protected (p. 100).*



Warning indicators and messages

Warning messages

- **CLOCK SET** Reset the date and time (p. 78).
- For “InfoLITHIUM” Use an “InfoLIHIUM” battery pack (p. 12).
BATTERY ONLY
-  **CLEANING CASSETTE**
The video heads are dirty (p. 121).
-  **FULL** The tape cassette memory is full.
-  **16BIT** AUDIO MODE is set to 16BIT.* You cannot dub new sound (p. 76).
-  **REC MODE** REC MODE is set to LP.* You cannot dub new sound (p. 76).
-  **TAPE** There is no recorded portion on the tape. You cannot dub new sound (p. 109).
-  **“i.LINK” CABLE** i.LINK cable is connected (p. 55).* You cannot dub new sound.
-  **FULL** The Memory Stick is full.* (DCR-TRV10 only) (p. 92)
-  **LOCK** The write-protect tab on the Memory Stick is set to LOCK (p. 79).* (DCR-TRV10 only)
-  **NO IMAGE** No still image is recorded on the Memory Stick (p. 85).* (DCR-TRV10 only)
-  **NO MEMORY STICK** No Memory Stick is inserted. (DCR-TRV10 only) (p. 81)

* You hear the melody or beep sound.

Using your camcorder abroad

Using your camcorder abroad

You can use your camcorder in any country or area with the AC power adaptor supplied with your camcorder within 100 V to 240 V AC, 50/60 Hz.

When charging the battery pack, use a commercially available AC plug adaptor [a], if necessary, depending on the design of the wall outlet [b].

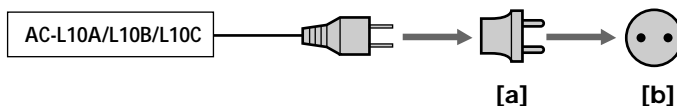

Your camcorder is an NTSC system based camcorder. If you want to view the playback picture on a TV, it must be an NTSC system based TV with VIDEO/AUDIO input jack. The following shows TV color systems used overseas.

NTSC system

Bahama Islands, Bolivia, Canada, Central America, Chile, Colombia, Ecuador, Jamaica, Japan, Korea, Mexico, Peru, Surinam, Taiwan, the Philippines, the U.S.A., Venezuela, etc.

PAL system

Australia, Austria, Belgium, China, Czech Republic, Denmark, Finland, Germany, Great Britain, Holland, Hong Kong, Italy, Kuwait, Malaysia, New Zealand, Norway, Portugal, Singapore, Slovak Republic, Spain, Sweden, Switzerland, Thailand, etc.

PAL-M system

Brazil

PAL-N system

Argentina, Paraguay, Uruguay

SECAM system



Bulgaria, France, Guyana, Hungary, Iran, Iraq, Monaco, Poland, Russia, Ukraine, etc.

Simple setting of clock by time difference

You can easily set the clock to the local time by setting a time difference. Select WORLD TIME in the MENU settings. See page 72 for more information.

Maintenance information and precautions

Moisture condensation

If your camcorder is brought directly from a cold place to a warm place, moisture may condense inside your camcorder, on the surface of the tape, or on the lens. In this condition, the tape may stick to the head drum and be damaged or your camcorder may not operate correctly. If there is moisture inside your camcorder, the beep sounds and the  indicator flashes. When the  indicator flashes at the same time, the cassette is inserted in your camcorder. If moisture condenses on the lens, the indicator will not appear.

If moisture condensation occurred

None of the functions except cassette ejection will work. Eject the cassette, turn off your camcorder, and leave it for about 1 hour with the cassette compartment open. Your camcorder can be used again if the  indicator does not appear when the power is turned on again.

Note on moisture condensation

Moisture may condense when you bring your camcorder from a cold place into a warm place (or vice versa) or when you use your camcorder in a hot place as follows:

- You bring your camcorder from a ski slope into a place warmed up by a heating device
- You bring your camcorder from an air-conditioned car or room into a hot place outside
- You use your camcorder after a squall or a shower
- You use your camcorder in a high temperature and humidity place

How to prevent moisture condensation



When you bring your camcorder from a cold place into a warm place, put your camcorder in a plastic bag and tightly seal it. Remove the bag when the air temperature inside the plastic bag has reached the surrounding temperature (after about 1 hour).

Maintenance information and precautions

Maintenance information

Cleaning the video head

To ensure normal recording and clear pictures, clean the video heads. The video head may be dirty when:

- mosaic-pattern noise appears on the playback picture.
- playback pictures do not move.
- playback pictures do not appear.
- the  indicator and “ CLEANING CASSETTE” message appear one after another or the  indicator flashes on the LCD screen or in the viewfinder.

If the above problem, [a] or [b] occurs, clean the video heads for 10 seconds with the Sony DVM12CL cleaning cassette (not supplied). Check the picture and if the above problem persists, repeat cleaning.

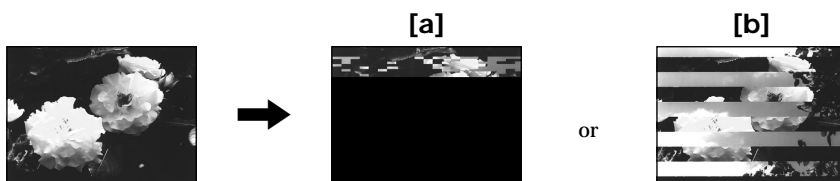

Cleaning the LCD screen

If fingerprints or dust make the LCD screen dirty, we recommend using a LCD Cleaning Kit (not supplied) to clean the LCD screen.

Charging the vanadium-lithium battery in your camcorder

Your camcorder is supplied with a vanadium-lithium battery installed so as to retain the date and time, etc., regardless of the setting of the POWER switch. The vanadium-lithium battery is always charged as long as you are using your camcorder. The battery, however, will get discharged gradually if you do not use your camcorder. It will be completely discharged in about a half year if you do not use your camcorder at all. Even if the vanadium-lithium battery is not charged, it will not affect the camcorder operation. To retain the date and time, etc., charge the battery if the battery is discharged.

Charging the vanadium-lithium battery:

- Connect your camcorder to house current using the AC power adaptor supplied with your camcorder, and leave your camcorder with the POWER switch turned off for more than 24 hours.
- Or install the fully charged battery pack in your camcorder, and leave your camcorder with the POWER switch turned off for more than 24 hours.

Precautions

Camcorder operation

- Operate your camcorder on 7.2 V (battery pack) or 8.4 V (AC power adaptor).
- For DC or AC operation, use the accessories recommended in this operating instructions.
- If any solid object or liquid get inside the casing, unplug your camcorder and have it checked by a Sony dealer before operating it any further.
- Avoid rough handling or mechanical shock. Be particularly careful of the lens.
- Keep the POWER switch set to OFF when you are not using your camcorder.
- Do not wrap your camcorder with a towel, for example, and operate it. Doing so might cause heat to build up inside.
- Keep your camcorder away from strong magnetic fields or mechanical vibration.
- Do not touch the LCD screen with your fingers or a sharp-pointed object.
- If your camcorder is used in a cold place, a residual image may appear on the LCD screen. This is not a malfunction.
- While using your camcorder, the back of the LCD screen may heat up. This is not a malfunction.

On handling tapes

- Do not insert anything into the small holes on the rear of the cassette. These holes are used to sense the type and thickness of the tape and if the recording tab is in or out.
- Do not open the tape protect cover or touch the tape.
- Avoid touching or damaging the terminals. To remove dust, clean the terminals with a soft cloth.

Camcorder care

- Remove the tape, and periodically turn on the power, operate the CAMERA and VTR sections and play back a tape for about 3 minutes when your camcorder is not to be used for a long time.
- Clean the lens with a soft brush to remove dust. If there are fingerprints on the lens, remove them with a soft cloth.
- Clean the camcorder body with a dry soft cloth, or a soft cloth lightly moistened with a mild detergent solution. Do not use any type of solvent which may damage the finish.
- Do not let sand get into your camcorder. When you use your camcorder on a sandy beach or in a dusty place, protect it from the sand or dust. Sand or dust may cause your camcorder to malfunction, and sometimes this malfunction cannot be repaired.

AC power adaptor

- Unplug the unit from the wall outlet when you are not using the unit for a long time. To disconnect the power cord, pull it out by the plug. Never pull the power cord itself.
- Do not operate the unit with a damaged cord or if the unit has been dropped or damaged.
- Do not bend the power cord forcibly, or place a heavy object on it. This will damage the cord and may cause fire or electrical shock.
- Prevent metallic objects from coming into contact with the metal parts of the connecting section. If this happens, a short may occur and the unit may be damaged.
- Always keep metal contacts clean.
- Do not disassemble the unit.
- Do not apply mechanical shock or drop the unit.
- While the unit is in use, particularly during charging, keep it away from AM receivers and video equipment. AM receivers and video equipment disturb AM reception and video operation.

Maintenance information and precautions

- The unit becomes warm during use. This is not a malfunction.
- Do not place the unit in locations that are:
 - Extremely hot or cold
 - Dusty or dirty
 - Very humid
 - Vibrating

Battery pack

- Use only the specified charger or video equipment with the charging function.
- To prevent accident from a short circuit, do not allow metal objects to come into contact with the battery terminals.
- Keep the battery pack away from fire.
- Never expose the battery pack to temperatures above 140°F (60°C), such as in a car parked in the sun or under direct sunlight.
- Keep the battery pack dry.
- Do not expose the battery pack to any mechanical shock.
- Do not disassemble nor modify the battery pack.
- Attach the battery pack to the video equipment securely.
- Charging while some capacity remains does not affect the original battery capacity.

Notes on dry batteries

To avoid possible damage from battery leakage or corrosion, observe the following:

- Be sure to insert the batteries with the + - polarities matched to the + - marks.
- Dry batteries are not rechargeable.
- Do not use a combination of new and old batteries.
- Do not use different types of batteries.
- Current flows from batteries when you are not using them for a long time.
- Do not use leaking batteries.

If batteries are leaking



- Wipe off the liquid in the battery compartment carefully before replacing the batteries.
- If you touch the liquid, wash it off with water.
- If the liquid get into your eyes, wash your eyes with a lot of water and then consult a doctor.

If any problem occurs, unplug your camcorder and contact your nearest Sony dealer.

Specifications

Video camera recorder

System

Video recording system
2 rotary heads
Helical scanning system
Audio recording system
Rotary heads, PCM system
Quantization: 12 bits (Fs 32 kHz, stereo 1, stereo 2), 16 bits (Fs 48 kHz, stereo)
Video signal
NTSC color, EIA standards
Usable cassette
Mini DV cassette with the **Mini DV** mark printed
Tape speed
SP: Approx. 18.81 mm/s
LP: Approx. 12.56 mm/s
Recording/playback time (using cassette DVM60)
SP: 1 hour
LP: 1.5 hours
Fastforward/rewind time (using cassette DVM60)
Approx. 1 min. and 45 seconds (AC power adaptor)
Approx. 2 min. and 30 seconds (battery pack)
Viewfinder
Electric viewfinder (color)
Image device
1/4 inch CCD (Charge Coupled Device)
Approx. 680,000 pixels (Effective: Approx. 340,000 pixels)
Lens
Combined power zoom lens
Filter diameter 30 mm.
(1 3/16 in.)
10× (Optical), 120× (Digital)
Focal length
5/32 - 1 5/16 in. (3.3 - 33 mm)
When converted to a 35 mm still camera
1 11/16 - 16 5/8 in. (42 - 420 mm)
Color temperature
Auto, HOLD (Hold),  Indoor (3200K),  Outdoor (5800K)
Minimum illumination
5 lux (F 1.7)
0 lux (in the NightShot mode)**
** Objects unable to be seen due to the dark can be shot with infrared lighting.

Input/Output connectors

S video input/output
4-pin mini DIN
Luminance signal: 1 Vp-p, 75 ohms, unbalanced
Chrominance signal: 0.286 Vp-p, 75 ohms, unbalanced

Audio/Video input/output
AV MINI JACK, 1 Vp-p, 75 ohms, unbalanced, sync negative
327 mV, (at output impedance more than 47 kilohms)
Output impedance with less than 2.2 kilohms/Stereo minijack (ø 3.5mm)
Input impedance more than 47 kilohms
 DV input/output
4-pin connector
Headphone jack
Stereo minijack (ø 3.5 mm)
LANC control jack
Stereo mini-minijack (ø 2.5 mm)
MIC jack
Minijack, 0.388 mV low impedance with 2.5 to 3.0 V DC, output impedance 6.8 kilohms (ø 3.5 mm)
Stereo type

LCD screen

Picture
3.5 inches measured diagonally
2 7/8 × 2 in. (72.4 × 50.4 mm)
Total dot number
DCR-TRV8: 105,380 (479 × 220)
DCR-TRV10: 184,580 (839 × 220)

General

Power requirements
7.2 V (battery pack)
8.4 V (AC power adaptor)
Average power consumption (when using the battery pack)
During camera recording using LCD
DCR-TRV8: 3.6W
DCR-TRV10: 3.8W
Viewfinder
2.9 W
Operating temperature
32 °F to 104 °F (0 °C to 40 °C)
Storage temperature
-4 °F to +140 °F (-20 °C to +60 °C)
Dimensions (Approx.)
2 3/4 × 3 5/8 × 6 1/4 in.
(67.5 × 89 × 157.5 mm) (w/h/d)
Mass (approx.)
DCR-TRV8:
1 lb 6 oz (630 g)
DCR-TRV10:
1 lb 6 oz (650 g)
excluding the battery pack, cassette and shoulder strap
DCR-TRV8:
1 lb 9 oz (730 g)
DCR-TRV10:
1 lb 10 oz (750 g)
including the battery pack, NP-FM50, cassette DVM60, lens cap and shoulder strap
Supplied accessories
See page 8.

AC power adaptor

Power requirements
100 - 240 V AC, 50/60 Hz
Power consumption
23 W
Output voltage
DC OUT: 8.4 V, 1.5 A in the operating mode
Operating temperature
32 °F to 104 °F (0 °C to 40 °C)
Storage temperature
-4 °F to +140 °F (-20 °C to +60 °C)
Dimensions (approx.)
5 × 1 9/16 × 2 1/2 in.
(125 × 39 × 62 mm) (w/h/d) excluding projecting parts
Mass (approx.)
9.8 oz (280 g)
excluding power cord
Cord length (approx.)
Power cord: 6.6 feet (2 m)
Connecting cord: 5.2 feet (1.6 m)

Battery pack

Output voltage
DC 7.2 V
Capacity
8.5 Wh
Dimensions (approx.)
1 9/16 × 13/16 × 2 1/4 in.
(38.2 × 20.5 × 55.6 mm) (w/h/d)
Mass (approx.)
2.7 oz (76 g)
Type
Lithium ion

Memory Stick (DCR-TRV10 only)

Memory
Flash memory
4MB: MSA-4A
Operating voltage
2.7-3.6V
Power consumption
Approx. 45mA in the operating mode
Approx. 130µA in the standby mode
Dimensions (approx.)
2 × 1/8 × 7/8 in.
(50 × 2.8 × 21.5 mm) (w/h/d)
Mass (approx.)
0.14 oz (4 g)

Design and specifications are subject to change without notice.

Identifying the parts and controls

- 1 Viewfinder lens adjustment lever
(p. 18)
- 2 OPEN button (p. 15)
- 3 SEL/PUSH EXEC dial (p. 32, 72)

This mark indicates that this product is a genuine accessory for Sony video products.

When purchasing Sony video products, Sony recommends that you purchase accessories with this “GENUINE VIDEO ACCESSORIES” mark.



Identifying the parts and controls

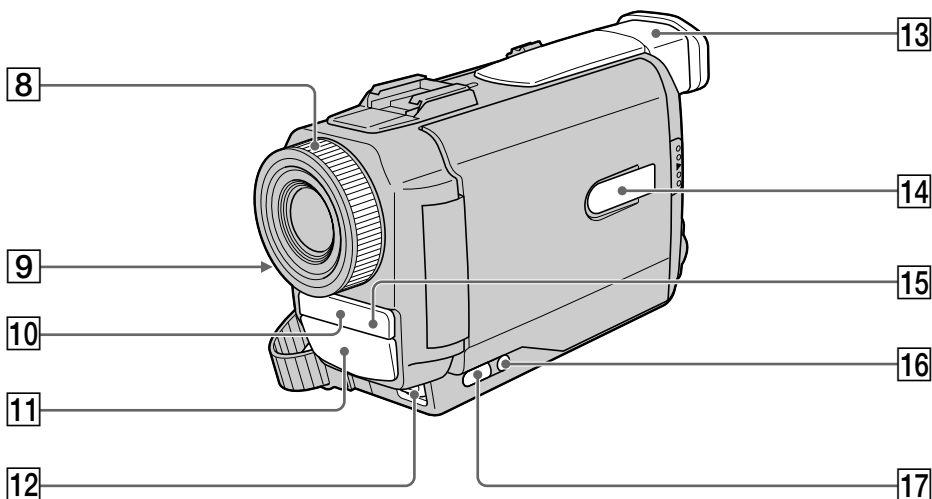

8 Focus ring (p. 45)

9 Camera recording lamp (p. 15)

10 Infrared rays emitter (p. 21, 29)

11 Microphone

12 FOCUS switch (p. 45)

13 Viewfinder (p. 9, 18)

14 Display window (p. 134)

15 Remote sensor (p. 132)

16 BACK LIGHT button (p. 21)

17 FADER button (p. 34)

Note on the Carl Zeiss lens

Your camcorder is equipped with a Carl Zeiss lens which can reproduce a fine image.

The lens for your camcorder was developed jointly by Carl Zeiss, in Germany, and Sony Corporation. It adopts the MTF* measurement system for video camera and offers a quality as the Carl Zeiss lens.

* MTF is an abbreviation of Modulation Transfer Function/Factor.

The value number indicates the amount of light of a subject penetrating into the lens.

Identifying the parts and controls

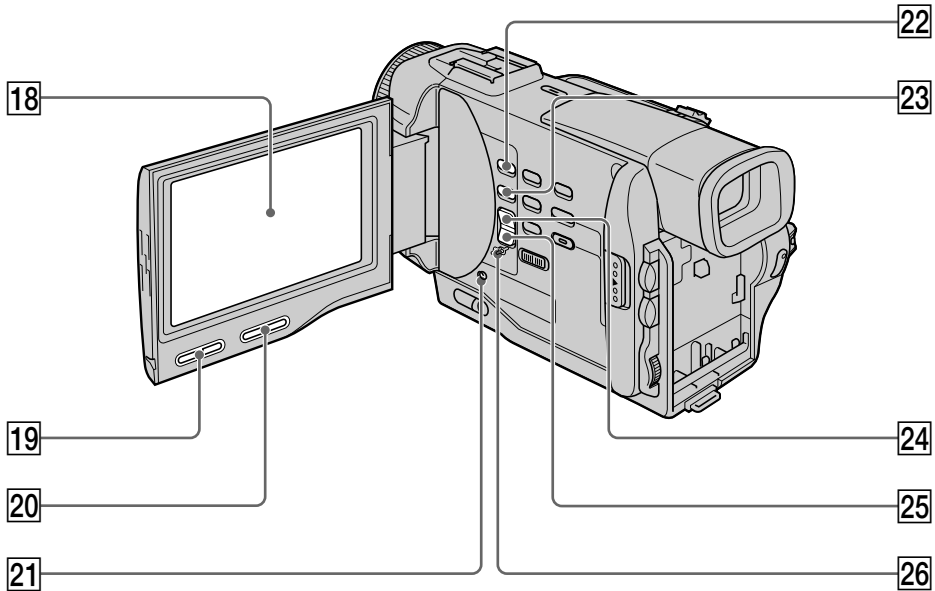

- 18** LCD screen (p. 17)
- 19** LCD BRIGHT buttons (p. 17)
- 20** VOLUME buttons (p. 25)
- 21** RESET button (p. 115)
- 22** MEMORY PLAY button (p. 93, 98)
(DCR-TRV10 only)
- 23** MEMORY INDEX button
(DCR-TRV10 only) (p. 94)
- 24** MEMORY + button
(DCR-TRV10 only) (p. 93, 98)
- 25** MEMORY - button
(DCR-TRV10 only) (p. 93, 98)
- 26** MEMORY DELETE button
(DCR-TRV10 only) (p. 102)



Notes on the intelligent accessory shoe

- The intelligent accessory shoe supplies power to optional accessories such as a video light or microphone.
- The intelligent accessory shoe is linked to the POWER switch, allowing you to turn the power supplied by the shoe on and off. Refer to the operating instructions of the accessory for further information.
- The intelligent accessory shoe has a safety device for fixing the installed accessory securely. To connect an accessory, press down and push it to the end, and then tighten the screw.
- To remove an accessory, loosen the screw, and then press down and pull out the accessory.

Identifying the parts and controls

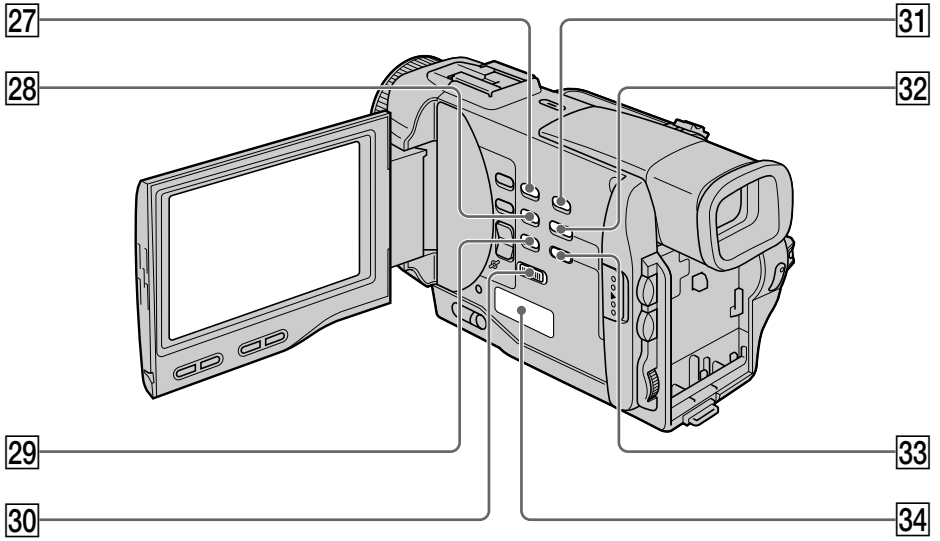

27 SELFTIMER button (p. 23)

28 END SEARCH button (p. 24)

29 DISPLAY button (p. 26)

30 START/STOP MODE switch (p. 20)

31 DIGITAL EFFECT button (p. 39, 47)

32 TITLE button (p. 66)

33 MENU button (p. 32, 72)

34 Speaker

Identifying the parts and controls

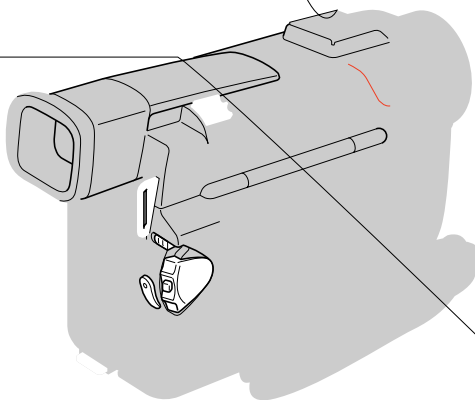

Quick Reference

Identifying the parts and controls

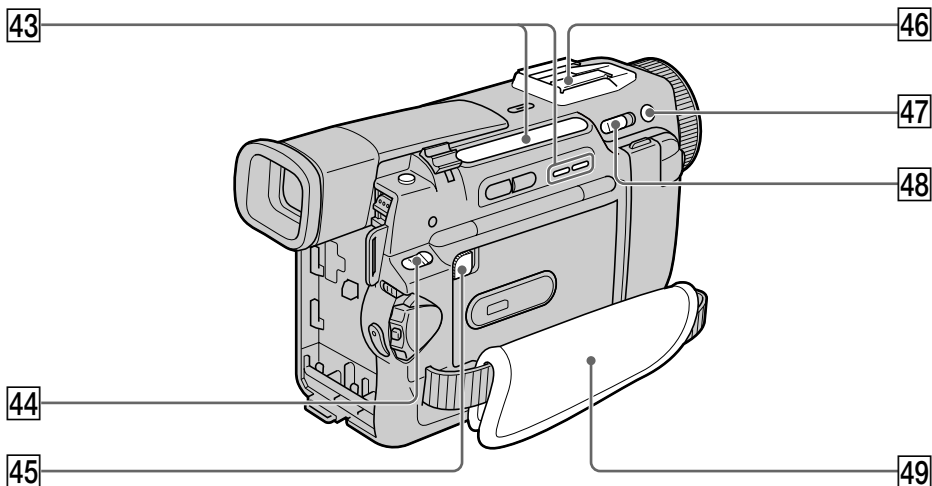

43 Video control buttons (p. 25, 27, 58)

- STOP (stop)
- ◀ REW (rewind)
- ▶ PLAY (playback)
- ▶▶ FF (fastforward)
- || PAUSE (pause)
- REC (recording)

The control buttons light up when you set the POWER switch to VTR.

44 MEMORY OPEN button
(DCR-TRV10 only) (p. 81)

45 MEMORY RELEASE button
(DCR-TRV10 only) (p. 81)

46 Intelligent accessory shoe (p. 61, 127)

47 +SLOW SHTR button (p. 21)

48 NIGHTSHOT switch (p. 21)

49 Grip strap

Fastening the grip strap

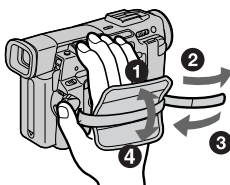

Fasten the grip strap firmly.

Identifying the parts and controls

Remote Commander

The buttons that have the same name on the Remote Commander as on your camcorder function identically to the buttons on your camcorder.

RMT-808

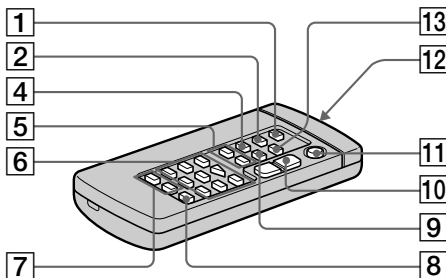

RMT-811

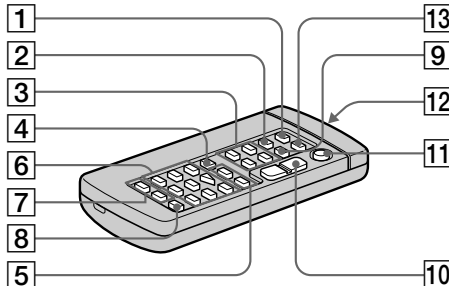

- | | |
|--|--|
| 1 PHOTO button (p. 30, 85) | 8 AUDIO DUB button (p. 63) |
| 2 DISPLAY button (p. 26) | 9 DATA CODE button (p. 26) |
| 3 Memory control buttons
(DCR-TRV10 only) (p. 93, 94, 98) | 10 Power zoom button (p. 19) |
| 4 SEARCH MODE button (p. 49, 51, 52) | 11 START/STOP button (p. 15) |
| 5 ◀▶/▶▶ buttons (p. 49, 51, 52) | 12 Transmitter
Point toward the remote sensor to
control your camcorder after turning on
your camcorder. |
| 6 Video control buttons (p. 27) | 13 ZERO SET MEMORY button (p. 48, 58) |
| 7 REC button (p. 58, 105)/MARK button
(DCR-TRV10 only) (p. 57) | |

To prepare the Remote Commander

Insert 2 size AA (R6) batteries by matching the + and - polarities on the batteries to the + - marks inside the battery compartment.

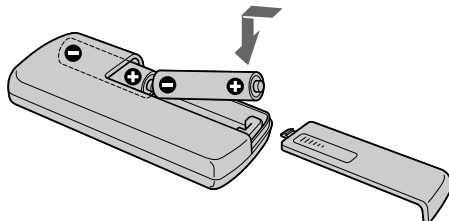

Notes on the Remote Commander

- Point the remote sensor away from strong light sources such as direct sunlight or overhead lighting. Otherwise, the Remote Commander may not function properly.
- Your camcorder works in the commander mode VTR 2. Commander modes 1, 2 and 3 are used to distinguish your camcorder from other Sony VCRs to avoid remote control misoperation. If you use another Sony VCR in the Commander mode VTR 2, we recommend changing the commander mode or covering the sensor of the VCR with black paper.

Operation indicators

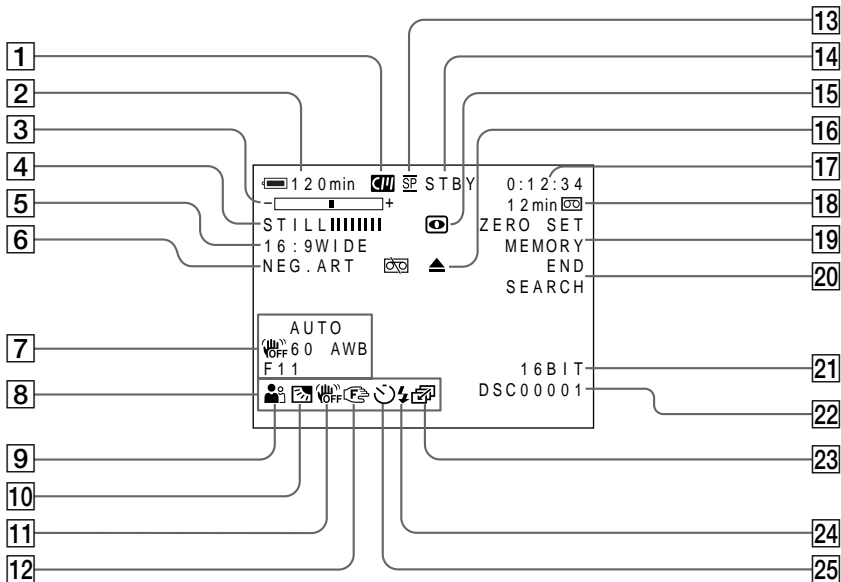

- | | |
|--|--|
| <ul style="list-style-type: none"> 1 Cassette memory indicator (p. 109) 2 Remaining battery time indicator (p. 20) 3 Zoom indicator (p. 19)/Exposure indicator (p. 44)/Data file name indicator (DCR-TRV10 only) (p. 79) 4 Digital effect indicator (p. 39)/M.CHROM/M.LUMI/C.CHROM indicator (DCR-TRV10 only) (p. 98) 5 FLD./FRAME indicator (DCR-TRV10 only) (p. 85)/16:9WIDE indicator (p. 32)/FADER indicator (p. 34) 6 Picture effect indicator (p. 36) 7 Data code indicator (p. 26) | <ul style="list-style-type: none"> 8 LCD bright indicator (p. 17)/Volume indicator (p. 25) 9 PROGRAM AE indicator (p. 43) 10 Backlight indicator (p. 21) 11 SteadyShot off indicator (p. 73) 12 Manual focus/Infinity indicator (p. 45) 13 Recording mode indicator (p. 76) 14 Standby/Recording indicator (p. 15)/Video control mode indicator (p. 27)/Image quality mode indicator (DCR-TRV10 only) (p. 82) 15 NIGHTSHOT indicator (p. 21) 16 Warning indicators (p. 117) |
|--|--|

Identifying the parts and controls

- 17 Tape counter indicator (p. 48)/5SEC mode indicator (p. 20)/Time code indicator (p. 20)/Self-diagnosis indicator (p. 116)/Photo mode indicator (p. 30)/Image number indicator (DCR-TRV10 only) (p. 94)
- 18 Remaining tape indicator (p. 20)/Memory playback indicator (DCR-TRV10 only) (p. 94)
- 19 ZERO SET MEMORY indicator (p. 48)
- 20 END SEARCH indicator (p. 24)
- 21 Audio mode indicator (p. 76)
- 22 Data file name indicator (DCR-TRV10 only)
This indicator appears when the M.CHROM/M.LUMI/C.CHROM functions work.
- 23 Continuous mode indicator (DCR-TRV10 only) (p. 86)
- 24 Video flash ready indicator (p. 30)
This indicator appears when you use the video flash light (not supplied).
- 25 Self-timer indicator (p. 23)

Display window

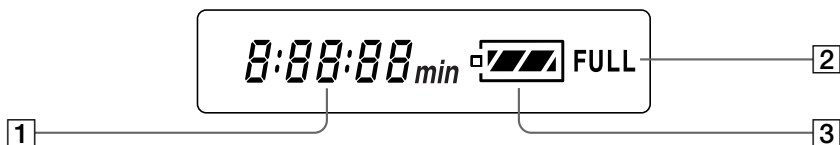

- 1 Remaining battery time indicator (p. 10)/Tape counter (p. 48)/Memory counter (DCR-TRV10 only) (p. 94)/Time code indicator (p. 20)
- 2 FULL charge indicator (p. 10)
- 3 Remaining battery indicator (p. 10)

Quick Function Guide

Functions to adjust exposure (in the recording mode)

- In a dark place NIGHTSHOT (p. 21)
- In insufficient light Low lux mode (p. 42)
- In dark environments such as sunset, fireworks, or general night views Sunset & moon mode (p. 42)
- Shooting backlit subjects BACK LIGHT (p. 21)
- In spotlight, such as at the theater or a formal event Spotlight mode (p. 42)
- In strong light or reflected light, such as at a beach in midsummer or on a ski slope Beach & ski mode (p. 42)

Functions to give images more impact (in the recording mode)

- Smooth transition between scenes FADER (p. 33)
- Taking a still picture PHOTO (p. 30)
- Digital processing of images PICTURE EFFECT (p. 36)/
DIGITAL EFFECT (p. 38)
- Creating a soft background for subjects Soft portrait mode (p. 42)
- Superimposing a title TITLE (p. 65)

Functions to give a natural appearance to your recordings (in the recording mode)

- Preventing deterioration of picture quality in digital zoom D ZOOM [MENU] (p. 72)
- Focusing manually Manual focus (p. 45)
- Shooting distant subjects Landscape mode (p. 42)
- Recording fast-moving subjects Sports lesson mode (p. 42)

Functions to use in editing (in the recording mode)

- Watching the picture on a wide-screen TV Wide mode (p. 32)
- Viewing images using a personal computer (DCR-TRV10 only) Memory Stick (p. 79)

Functions to use after recording (in the playback mode)

- Digital processing of recorded images PICTURE EFFECT (p. 46)/
DIGITAL EFFECT (p. 47)
- Displaying the date/time or various settings when you recorded Data code (p. 26)
- Quickly locating a desired scene Zero set memory (p. 48)
- Searching for scenes having a title Title search (p. 51)
- Searching for scenes recorded in the photo mode Photo search (p. 52)
- Scanning scenes recorded in the photo mode Photo scan (p. 53)
- Playing back on monaural sound or sub sound HiFi SOUND [MENU] (p. 72)
- Playing back the picture on a TV without connecting a cord LASER LINK (p. 29)

Index

A, B

AC power adaptor	10
Adjusting viewfinder	18
ANTI GROUND SHOOTING	20
Audio dubbing	61
AUDIO MIX	63
Audio mode	76
AUTO SHTR	73
A/V connecting cable	28, 54, 56
BACK LIGHT	21
Battery pack	9
Beep	77
BOUNCE	33

C, D

Camera chromakey	96
Cassette memory	6, 109
Charging battery	10
Charging vanadium-lithium battery	121
Clock set	78
Connection (viewing on TV)	28
(dubbing a tape)	54
Continuous	86
Data code	26
Date search	49
DEMO	77
DIGITAL EFFECT	38
DISPLAY	26
Dual sound track tape	110
Dubbing a tape	54
DV connecting cable	55

E

EDITSEARCH	24
END SEARCH	24, 27
Exposure	44
External microphone (not supplied)	131

F, G, H

FADER	33
Fade in/out	33
FLASH MOTION	38
FOCUS	45
Format	84
Full charge	10
Grip strap	130
Heads	121
Headphone jack	131
HiFi SOUND	74

I, J, K, L

i.LINK	131
Image protection	100
Image quality mode	82
INDEX (Multiple) display	94
"InfoLITHIUM" battery	12
Infrared rays emitter	21, 29
JPEG	79
Labeling a cassette	70
LANC	131
LASER LINK	29
LCD screen	17
LUMINANCEKEY	38

M, N

Main sound	74
Manual focus	45
Memory chromakey	97
Memory luminancekey	97
Memory Stick	79
Menu settings	72
Mirror mode	17
Moisture condensation	120
MONOTONE	33
Mosaic fader	33
NIGHTSHOT	21
NightShot +Slow shutter	22
Normal charge	10
NTSC system	119

O, P, Q

OLD MOVIE	38
Operation indicators	133
OVERLAP	33
Photo scan	53
Photo search	52
Photo recording	30
PICTURE EFFECT	36
Picture search	27
Playback pause	27
Power sources (house current)	13
(car battery)	13
(battery pack)	9
Power zoom	19
Print mark	101
PROGRAM AE	42

R

Rec review	24
Recording time	11
Remaining battery time indicator	20
Remaining tape indicator	20
Remote commander	132
Remote control jack (LANC)	131
Remote sensor	132
RESET	115

S

S video jack	28, 54, 56
Self-diagnosis display	116
Self-timer recording	23
SEL/PUSH EXEC dial	32, 72
Serial port adaptor	96
Shoulder strap	129
Skip scan	27
Slide show	107
Slow playback	27
SLOW SHUTTER	38
+SLOW SHTR	22
START/STOP MODE	20
STEADYSHOT	73
Stereo tape	110
STILL	38
Sub sound	74

T, U, V

Tape counter	20, 48
Telephoto	19
Time code	20
Title	65
Title search	51
TRAIL	38
Transition	16
TV color systems	119

W, X, Y, Z

Warning indicators	117
Wide-angle	19
Wide mode	32
WORLD TIME	77
Write-protect tab	14
Zero set memory	48
Zoom	19