

THERMAL PRINTER

TSP400 Series

TECHNICAL MANUAL

[THIRD EDITION]

NOTICE

- *All rights reserved. Reproduction of any part of this manual in any form whatsoever, without STAR's express permission is forbidden.*
- *The contents of this manual are subject to change without notice.*
- *All efforts have been made to ensure the accuracy of the contents of this manual at the time of going to press. However, should any errors be detected, STAR would greatly appreciate being informed of them.*
- *The above notwithstanding, STAR can assume no responsibility for any errors in this manual.*

INTRODUCTION

This manual is intended as a reference for maintenance personnel carrying out periodic maintenance or repair in the field. It is not intended for general users.

- This manual is comprised of the following chapters.
 - Chapter 1 Specifications and Operation
 - Chapter 2 Theory of Operation
 - Chapter 3 Parts Replacement and Related Adjustments
 - Chapter 4 Maintenance and Lubrication
 - Chapter 5 Parts Lists
- First edition : Dec. 1994
- Second edition : Jul. 1995
- Third edition : March 1997

■ Model Name

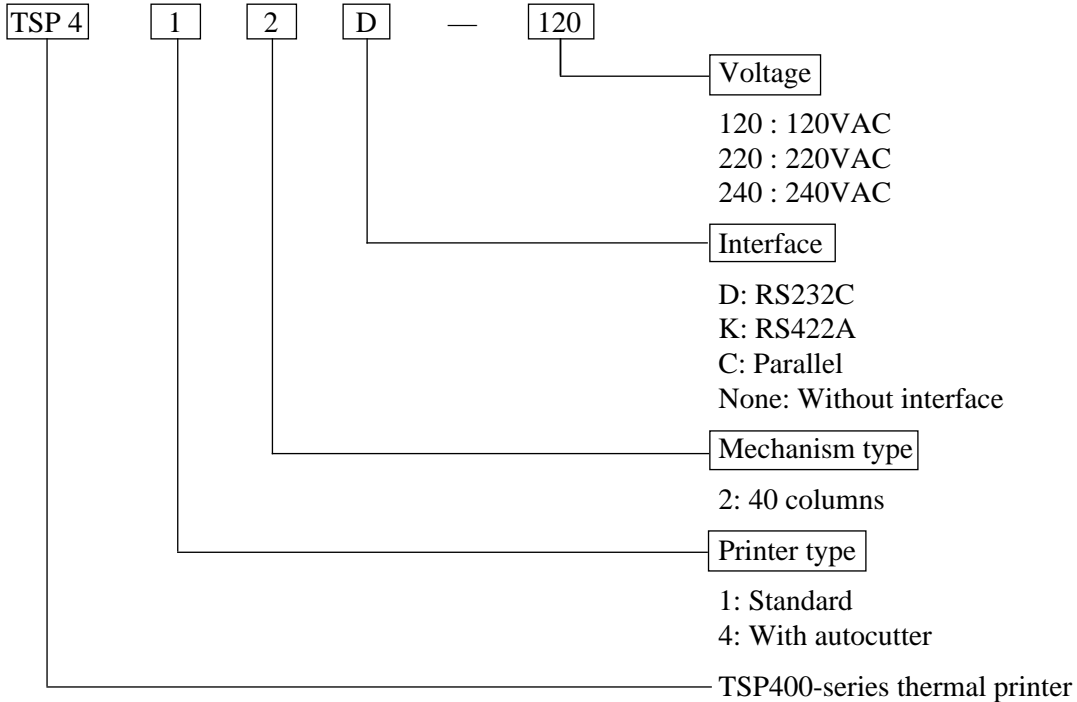

1

2

3

4

5

CHAPTER 1

SPECIFICATIONS AND OPERATION

1. General Specifications	3
2. External Appearance and Internal Configuration	4
3. DIP-Switch Settings	5
4. Print-Density Adjustment	8
5. Sensor Adjustment	9
6. Setting Memory Switches from the Control Panel	11
7. Test Print	12
8. HEX Dump	12
9. Page/Line Mode Switch	13
10. Exposing the Peripheral Unit Connector	14
11. Changing the Interface Board	15

1. General Specifications

Printing method	Line thermal direct	
Resolution	8 dots/mm (H) × 8 dots/mm (V)	
Printable width	75 mm in Line Mode; 80 mm in Page Mode	
Printing speeds	50 mm/sec and 25 mm/sec	
Printable characters	1 Page mode: ANK, International 2 Line mode: ANK, International, Special, Block graphic, IBM special, IBM block graphic, Kanji NOTE: ANK is comprised of ASCII characters and katakana	
Character matrixes	1 Page mode Small 8×16 Standard 16×24 Wide 24×32 OCR-B 16×24 2 Line mode Kanji 24×24 (12×24) IBM block graphic 12×24 or 12×32 All others 12×24	
Paper		
Recommended brands	TF50KS-E, TF62KS-E (Nippon Paper Industries) KP50-HEAEX (New Oji Paper Co., Ltd.)	
Width	82 mm (3.25 inches)	
Thickness	60 to 150 μm	
Roll diameters	External 115 mm max.	
Internal	25.4 mm (1 inch)	
Interface	RS232C, RS422A, or Parallel	
Dimensions and weight	Width 178 mm (TSP412D) 178 mm (TSP442D) Depth 226 mm (TSP412D) 244 mm (TSP442D) Height 256 mm (TSP412D) 256 mm (TSP442D) Weight 3.4 kg (TSP412D) 3.7 kg (TSP442D)	
Power supply	120VAC, 220VAC, 240VAC	
Ambient conditions	Operating 5°C to 40°C; 25%RH to 85%RH Nonoperating -20°C to 60°C; 10%RH to 90%RH	
Autocutter	Lifetime 300,000 cuts (if paper debris is cleared) Minimum cut length 25.4 mm (1 inch)	

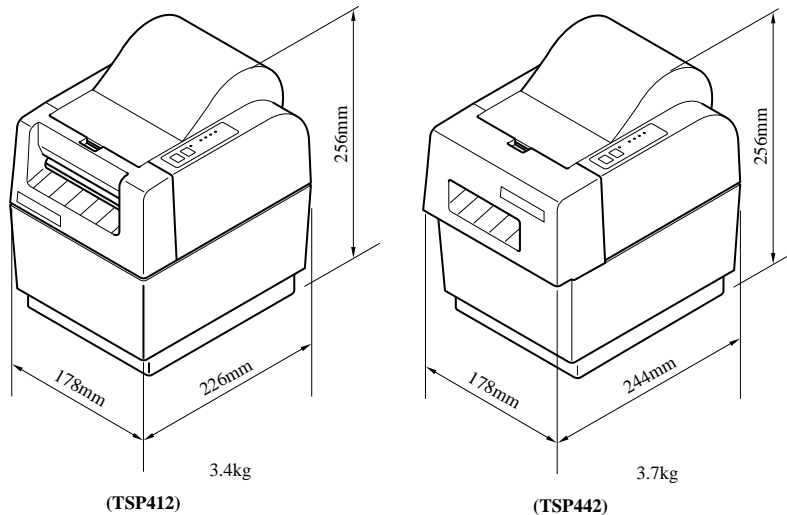

Fig. 1-1 External Dimensions

2. External Appearance and Internal Configuration

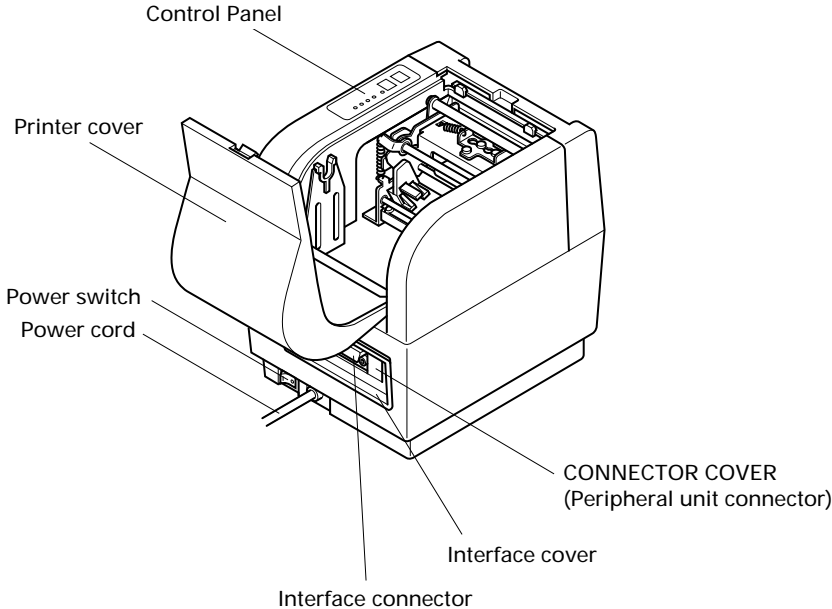

Fig. 1-2 Internal Configuration (TSP412D)

3. DIP-Switch Settings

DIP switches are located on the interface PCB. The number of switches depends on the interface type.

- (1) Setting the DIP Switches

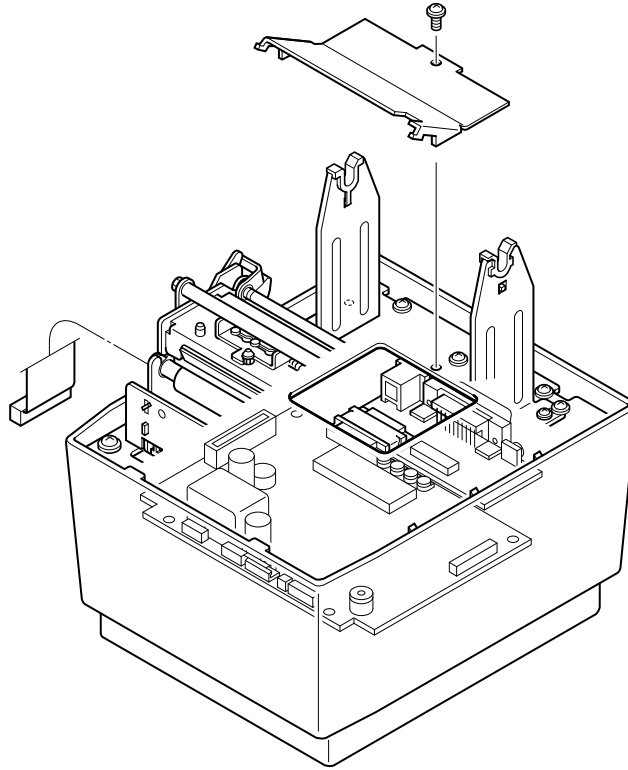

Fig. 1-3 DIP-Switch Settings

- 1 Remove the screw holding the ROM cover in place. (The screw is located at the base of the paper-roll holder.)
- 2 Remove the ROM cover, exposing the main and interface PCBs.

SPECIFICATIONS AND OPERATION

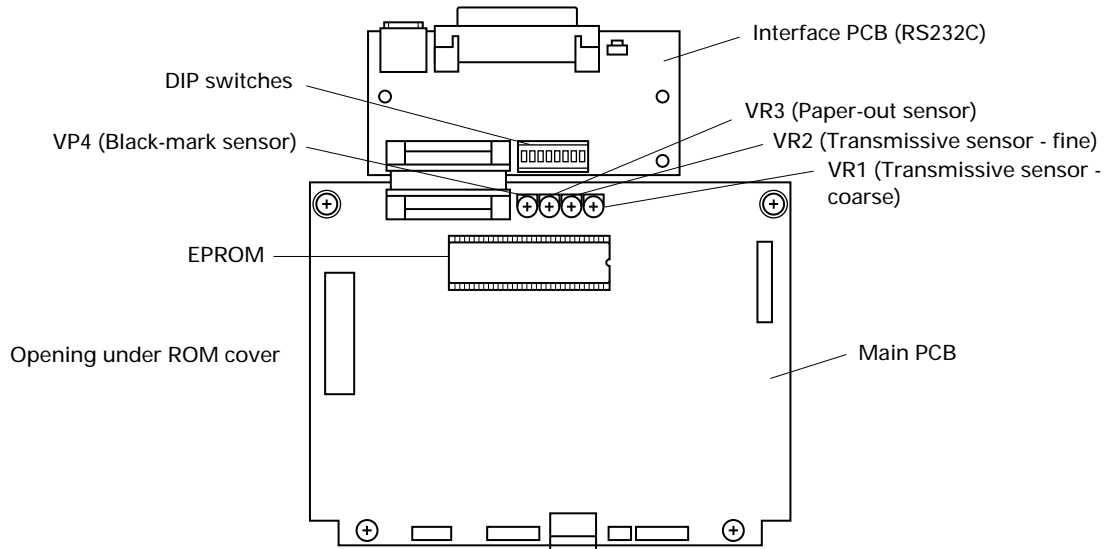

Fig. 1-4 Main and interface PCBs

3 Set the DIP switches on the interface PCB.

2. DIP-switch values

1 RS232C interface

This board has a single 8-bit DIP switch. Switch settings are as follows.

Switch	Setting	ON	OFF
1-1	Baud		
1-2			
1-3	Handshaking	DTR	XON/XOFF
1-4	Data length	8 bits	7 bits
1-5	Parity use	No parity	Parity used
1-6	Parity type	Odd	Even
1-7	DC1/DC3	Ineffective	Effective
1-8	Status of printer power		

* All of these are set to ON before the printer is shipped from the factory.

SPECIFICATIONS AND OPERATION

Baud	1-1	1-2
2400BPS	OFF	OFF
4800BPS	OFF	ON
9600BPS	ON	ON
19200BPS	ON	OFF

Mode	Status of printer power	
	1-8 ON	1-8 OFF
DC1/DC3 invalid	Printer selected	Printer de-selected
DC1/DC3 effective	Printer selected	Printer de-selected
Addressable	Printer de-selected	Printer selected

To select a mode:

With an RS-232C interface, use DIP switches 1-7 to select the mode. With an RS-422A interface, use DIP switch #2.

2 RS422A interface

This board has two DIP-switches: one 8-bit switch and one 4-bit switch.

DIP switch #1 (8 bits):

Identical to the DIP switch on the RS232C (see above). But note that bit 1-7 is meaningless.

DIP switch #2 (4 bits):

	SW2-1	SW2-2	SW3-3	SW2-4
DC1,3 off	ON	ON	ON	ON
Address #1	OFF	ON	ON	ON
#2	ON	OFF	ON	ON
#3	OFF	OFF	ON	ON
#4	ON	ON	OFF	ON
#5	OFF	ON	OFF	ON
#6	ON	OFF	OFF	ON
#7	OFF	OFF	OFF	ON
#8	ON	ON	ON	OFF
#9	OFF	ON	ON	OFF
#10	ON	OFF	ON	OFF
#11	OFF	OFF	ON	OFF
#12	ON	ON	OFF	OFF
#13	OFF	ON	OFF	OFF
#14	ON	OFF	OFF	OFF
DC1,3 mode on	OFF	OFF	OFF	OFF

* DIP-SW #2 overrides the DIP-SW #1 DC1/3 setting (bit 1-7).

* DIP-SW #2 factory setting: All ON

3 Parallel (Centronics) interface

The parallel-interface board has no DIP switches.

SPECIFICATIONS AND OPERATION

4. Print-Density Adjustment

Adjust the print density in accordance with the sensitivity of the paper being used. The adjustment procedure is as follows.

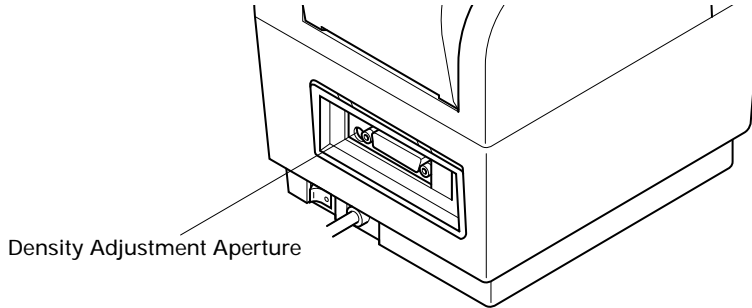
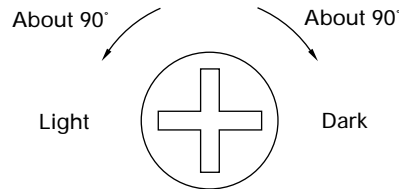

Fig. 1-5 Print-Density Adjustment

- 1 Remove the interface cover, located the rear side of the printer. The cover fits into place; no screws are used.
- 2 The density adjustor (variable resistor) is now accessible through the aperture located to the left of the interface connector.
- 3 Insert a screwdriver (regular or phillips-head) into the aperture and rotate as necessary. The adjustor has a rotational range of approximately 180 degrees.

4



- 5 Avoid setting density too high for sensitive paper types. Excessive dark values may cause the paper to swell, degrading the image quality.
- 6 Some thermal papers may fail to produce a strong image when running at 50mm/sec printing speed, even at maximum density setting. If you have this problem, reduce the print speed to 25mm/sec.

5. Sensor Adjustment

There are three different sensors: the transmissive sensor (label start-position detector), the black-mark sensor, and the paper-out sensor. Adjustment procedures are described below. First note the following general points.

- The transmissive sensor level requires precise setting. Because transmission rates vary widely among different types of label paper, we recommend that the sensor be readjusted each time the user changes to a different paper type.
- Because black marks are likely to be similar across different paper types, the black-mark reflective sensor may not require readjustment each time the paper type is changed. But you will still have to adjust it if the new paper has a different consistency or uses a different black-mark density, or if the paper-feed routing is changed.
- In most generally not necessary to adjust the paper-out sensor.

SPECIFICATIONS AND OPERATION

Sensor adjustment procedures are as follows.

- 1) Remove the ROM cover, located beneath the paper-roll holding area.
- 2) Hold down the FEED and ON LINE buttons while switching on the power, and continue to hold them down until you hear a triple beep. (This will take about five seconds.) When you hear the triple beep, release the buttons to enter sensor-adjustment mode.
 - a) Reflective Sensor
 - Insert a non-black area of paper into the mechanism's sensor area.
 - Rotate the main PCB's reflective-sensor adjustment knob (VR4) to the point where the Head Up LED comes on.
 - b) Paper-Out Sensor
 - Insert a non-black area of paper into the mechanism's sensor area.
 - Rotate the main PCB's paper-out-sensor adjustment knob (VR3) to the point where the Paper End LED switches on.
 - c) Transmissive Sensor
 - Insert the backing portion of a label sheet into the mechanism's transmissive sensor area. (Insert the backing part only, not the label itself.)
 - Adjust the main PCB's coarse (VR1) and fine (VR2) transmissive-sensor adjustment knobs to the point where the Error LED comes on.

Note: When setting paper, be sure to lower the head so that it is close to its normal fixed position.

After the sensor has been adjusted, press the ON LINE switch to exit the sensor adjustment mode and return to the normal operation mode.

6. Setting Memory Switches from the Control Panel

The TSP400 uses EEPROM memory switches in place of corresponding hardware switches. All EEPROM switch settings can be changed by software. A number of these switches are also changeable from the control panel.

(1) Paper-Feed Mode (Continuous or Next-Top)

When the feed mode is set to next-top, the printer can come online only if loaded with labels or marked paper. If the printer fails to come online you will not be able to change the feed-mode setting by command; you will therefore have to change it using the control panel.

- 1 Hold down the FEED and ON LINE buttons while switching on the power, and continue to hold them down until you hear a double beep. (You will first hear a single beep, followed by a pause, followed by the double beep.) Release the buttons immediately after hearing the double beep.
- 2 Press the ON LINE button to select continuous feed (the printer beeps once), or press the FEED button to select next-top feed (the printer beeps twice). If you select next-top feed, the printer automatically starts paper feed and looks for the next top.

(2) Sensor Mode

The printer may be set to use either the transmissive or the reflective sensor for next-top detection. You can make this setting as follows.

- 1 Hold down the ON LINE button while switching on the power, then continue to hold it down until you hear a double beep. (You will first hear a single beep, then a pause, then the double beep.) Release the ON LINE button immediately after hearing the double beep.
- 2 Press the ON LINE button to select the reflective sensor (the buzzer beeps once), or press the FEED button to select the transmissive sensor (the buzzer beeps twice).

SPECIFICATIONS AND OPERATION

7. Test Print

To generate a test print (self-test), hold down the FEED button while switching on the power.

Note: The test print continues as long as the FEED button is held down.

8. HEX Dump

Set the printer into hex-dump mode as follows: hold down the ONLINE button and switch the power on, then release the ONLINE button as soon as you hear a single beep. The printer is now set to print a hex dump of the data sent from the host.

Note: The HEX Dump mode continues to be effective until the power supply is turned off.

9. Page/Line Mode Switch

The TSP400 series supports two entirely different command sets: “Page Mode” and “Line Mode.” You can select the mode either by software or from the control panel. To select from the control panel, proceed as follows.

NOTE: This function will not become meaningful until Line Mode software has been introduced.

- 1 Hold down the ON LINE button while switching on the power, then continue to hold it down until you hear a triple beep. (This will take about five seconds.)
- 2 Press the ON LINE button to select Page Mode (the buzzer beeps once), or press the FEED button to select Line Mode (the buzzer beeps twice).

SPECIFICATIONS AND OPERATION

10. Exposing the Peripheral Unit Connector

When operating in Line Mode, the printer can use the peripheral unit connector to drive a cash drawer or other such external device. But note that the connector is originally hidden by a portion of the interface cover.

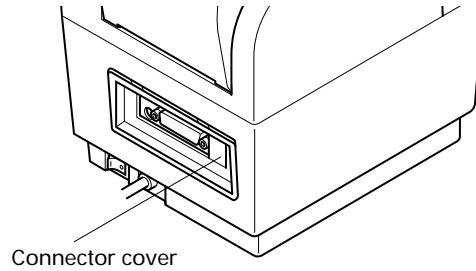

Fig. 1-6 Peripheral Unit Connector

To prepare the connector for use, remove the “connector cover” portion of the interface cover (see illustration) by gently bending and breaking it with a pliers. Be sure to remove any remaining burrs using a cutter or other such tool.

11. Changing the Interface Board

You can change the printer's interface by replacing the interface board. The replacement procedure is as follows.

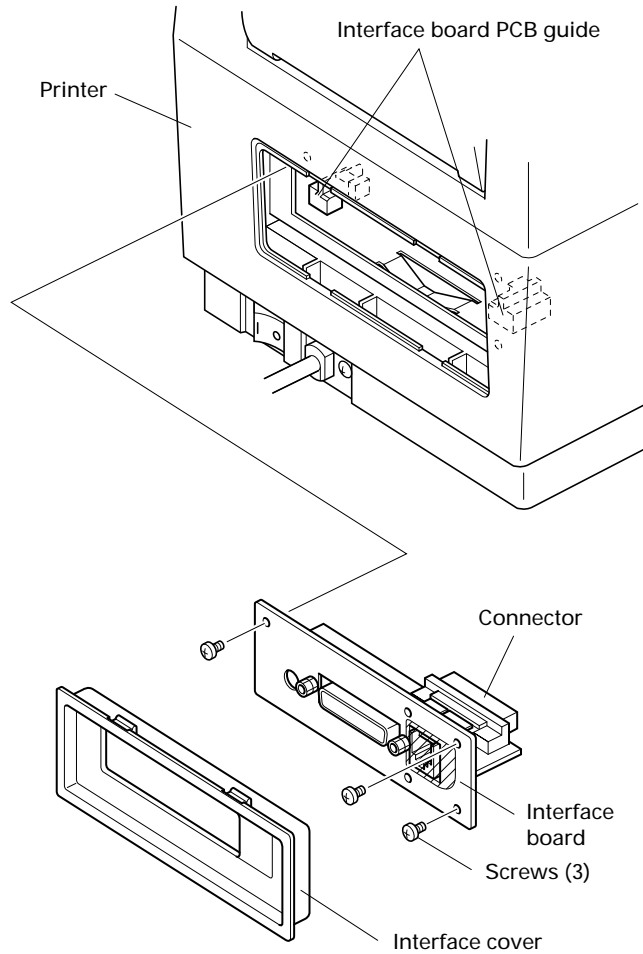

Fig. 1-7 Changing the Interface Board

- 1 Remove the interface cover, located on the rear side of the printer.
- 2 Remove the three screws holding the interface board in place.
- 3 Remove out the board by pulling on the pull sheet fastened to the connector.
- 4 Fit the replacement interface board to the guides and push all the way in so that the connector is fully engaged.
- 5 Fasten the outer plate to the printer with three screws.
- 6 Replace the interface cover.

Note: The printer automatically detects changes in interface type.

CHAPTER 2

THEORY OF OPERATION

This chapter describes the operating principles of the circuitry and printer mechanism.

2

1. Block Diagram	19
2. Main and Interface PCBs	21
2-1. Interface	21
2-1-1. RS232C	21
2-1-2. RS422A	22
2-1-3. Parallel interface	23
2-2. Editing and Printing	24
2-2-1. Editing	24
2-2-2. Thermal head	24
2-2-3. Head current control	25
2-3. Feed-Motor Drive Circuit	26
2-4. Power-On Reset Circuit	27
2-5. +5V Line Voltage Detector Circuit	28
3. Printer Mechanism	29
3-1. Thermal Head	29
3-2. Paper-Feed Mechanism	29
3-3. Detectors	30

1. Block Diagram

The following diagram illustrates the relationship between the control board (main PCB) and its peripherals.

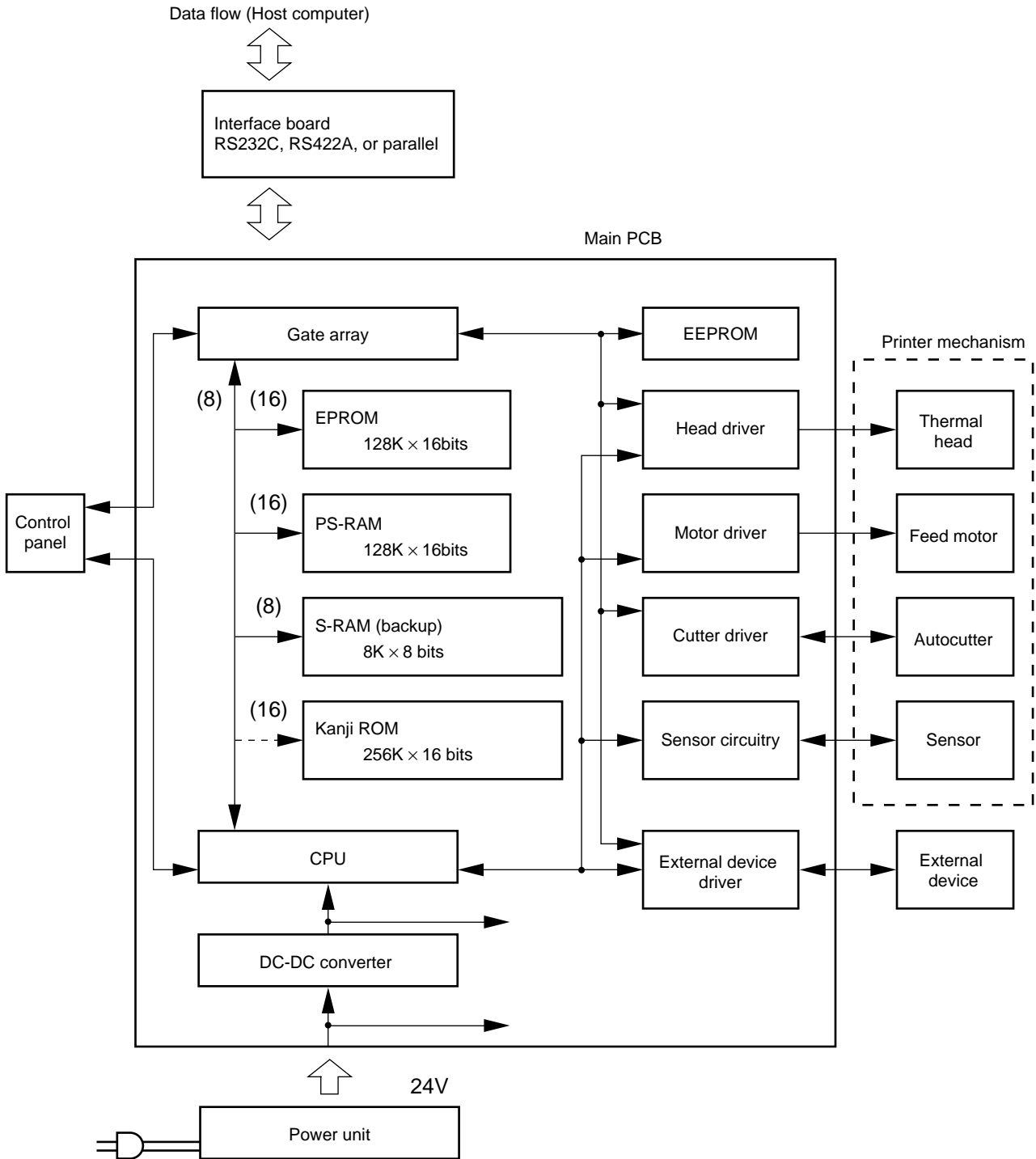

Fig. 2-1 Block Diagram

THEORY OF OPERATION

1.1 Control board

The interface board relays data from the host computer to the main board. The main board's CPU stores the data into local RAM.

It then reads out the data, edits it according to the control program stored in the board's ROM, and prints the results by issuing appropriate drive signals to the printer mechanism.

[Block Description]

- a. CPU: HD641300F10T
CMOS single-chip computer
Controls overall printer operation.
- b. EPROM: 128 K × 16 bits
Contains the CPU control program.
- c. PS-RAM: 128 K × 16 bits
Work area and data buffer
- d. S-RAM
Saves format data and externally defined characters.
Backed up by super capacitor.
- e. EEPROM: 1024 bits
Stores printer settings. Settings can be changed by software. (Used in place of dip-switches.)
- f. Interface board
Interfaces the main board with the host computer.
There are three versions, each for a different interface type: RS232C, RS422A, or Centronics parallel.
- g. Gate array
Executes various types of signal processing.
- h. Drivers
The various drivers convert signals received from the CPU and gate array into the drive signals that directly control the printer mechanism.
- i. DC-DC converter
Converts the supplied 24V to 5V.

1.2 Control Panel

Provides manual control switches and operational indicators.

1.3 Printer mechanism

Comprised of thermal head, paper-feed motor, and sensor mechanism.

1.4 Power unit

Converts primary power to DC24V.

1.5 External device

External device (such as cash drawer) driven by signals issued by the control board.

2. Main and Interface PCBs

The main PCB and interface PCB provide the drive circuitry for the TSP-400 printer series. The two boards are connected via 40-pin connectors.

2-1. Interface

2-1-1. RS232C interface

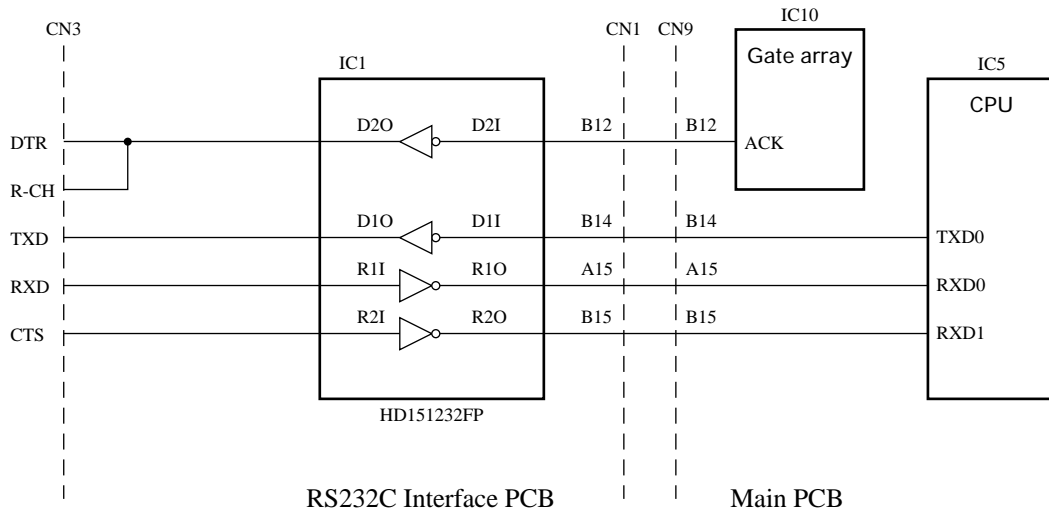

Fig. 2-2 RS232C Interface

Data flow from host to printer: IC1 receives serial data from the host computer via RXD, converts the signal voltage from RS232C level to TTL level, and passes the result to the CPU. The CPU converts the serial data to parallel and stores it into buffer memory.

Data flow from printer to host: The CPU generates data, converts it into serial form, then passes it to IC1. IC1 converts the signal voltage from TTL level to RS232C level, then outputs the result over the TXD line.

The CTS line is hardware-connected, but the connection is not recognized by software. (The printer does not monitor the signal.)

THEORY OF OPERATION

2-1-2. RS422A interface

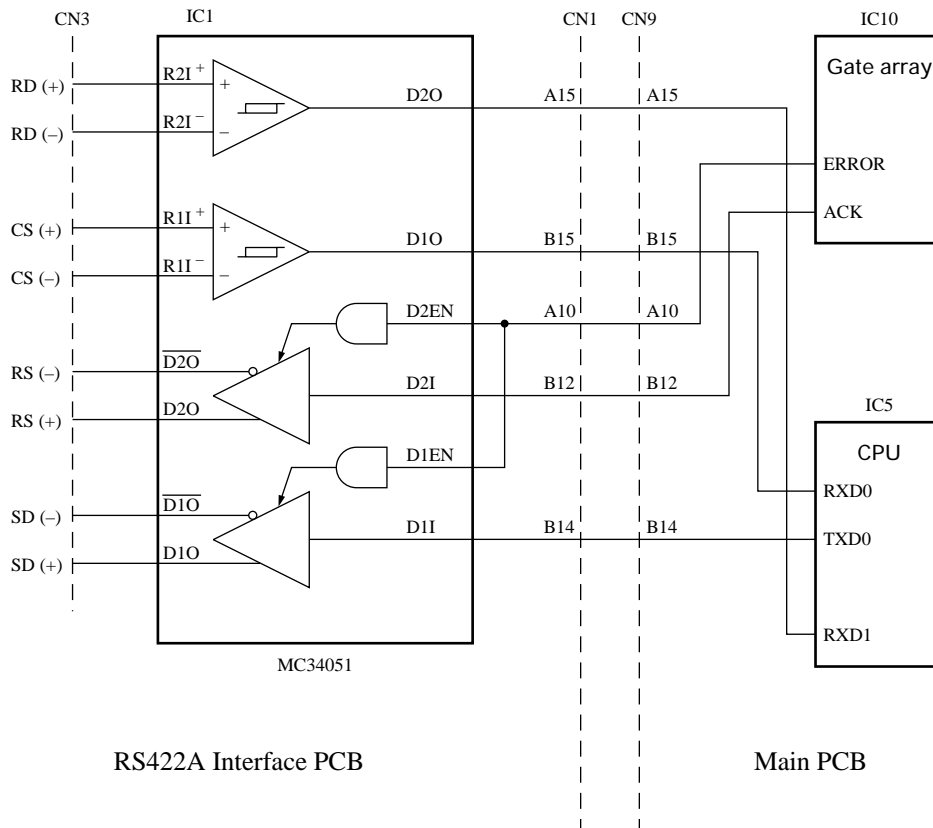

Fig. 2-3 RS422A Interface

IC1 operates as the RS422A driver and receiver.

Data flow from host to printer: IC1 receives serial data from the host computer via RD, converts the signal voltage from RS422A level to TTL level, and passes the result to the CPU. The CPU converts the serial data to parallel and stores it into buffer memory.

Data flow from printer to host: The CPU generates data, converts it into serial form, then passes it to IC1. IC1 converts the signal voltage from TTL level to RS422A level, then outputs the result over the SD line.

The CS line is hardware-connected, but the connection is not recognized by software. (The printer does not monitor the signal.)

2-1-3. Parallel interface

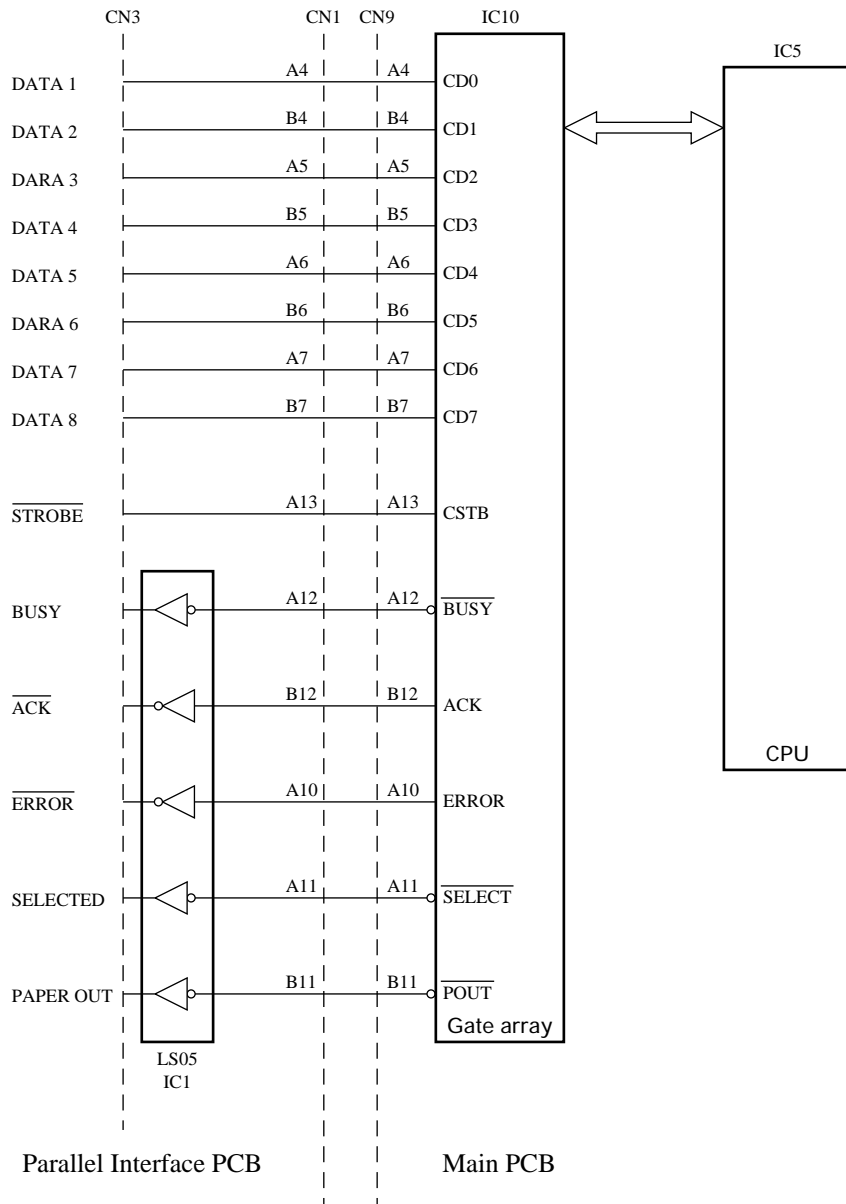

Fig. 2-4 Parallel Interface

The host computer sends eight bits of parallel data to CN3 when the printer is ready (when BUSY is LOW). The data passes through the interface PCB and gate array, then moves into the CPU.

Printer signals from the CPU (ACK, ERROR, SELECTED, PAPER OUT, etc.) pass through the gate array and are output over the appropriate connector pins.

THEORY OF OPERATION

2-2. Editing and Printing

2-2-1. Editing

The CPU reads data sequentially from RAM and edits it in accordance with program instructions stored in EPROM. The edited data undergoes parallel-to-serial conversion in the gate array, and is then output to the thermal head's drive controller.

2-2-2. Thermal head

The thermal head contains 640 heat elements. Printing is carried out by switching these elements ON or OFF as required.

Note that Line Mode supports 600-dot printing only. During Line Mode operation, therefore, the logic always sends OFF data to elements 1 to 20 and 621 to 640.

The thermal head contains a dedicated drive controller. The controller consists of a shift register, a latch circuit, and a driver circuit, as illustrated below. The drive controller receives serial data (SI) from the drive control board in sync with the CLOCK signal. The controller latches the incoming data (LATCH), then outputs it to the heat elements in sync with the trailing edge of the STROBE signals. A data value of LOW corresponds to a heat-element value of ON.

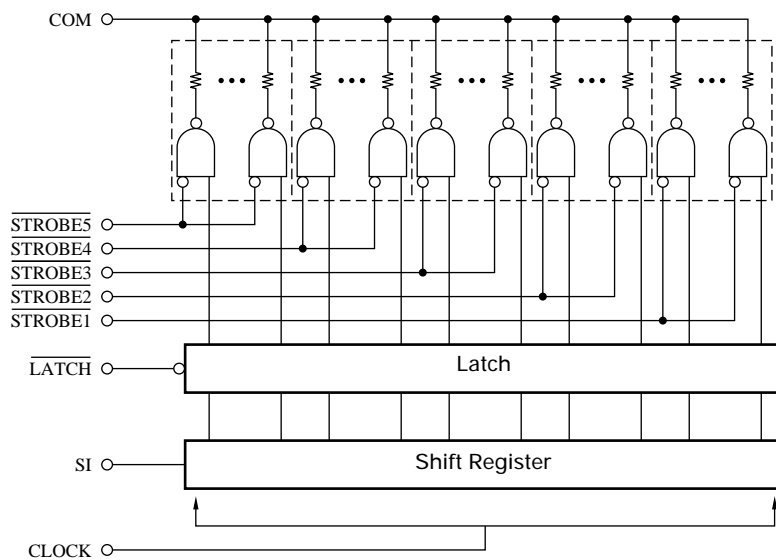

Fig. 2-5 Thermal-Head Drive Circuit

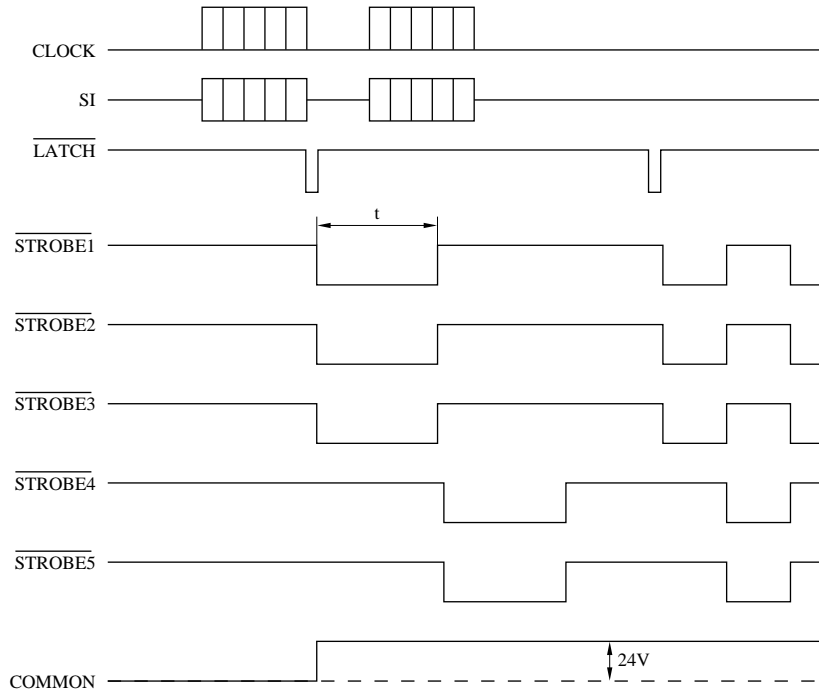

Fig.2-6 Timing Chart

2-2-3. Head current control

Heat buildup in the head during operation can cause print quality to degrade. To maintain uniform quality, the printer varies the energizing time (time that STROBE remains LOW) in accordance with the head temperature. The thermal head's surface temperature is calculated based on the resistance value of an attached thermistor. Energizing time is reduced at higher temperatures, as indicated in the figure 2-6.

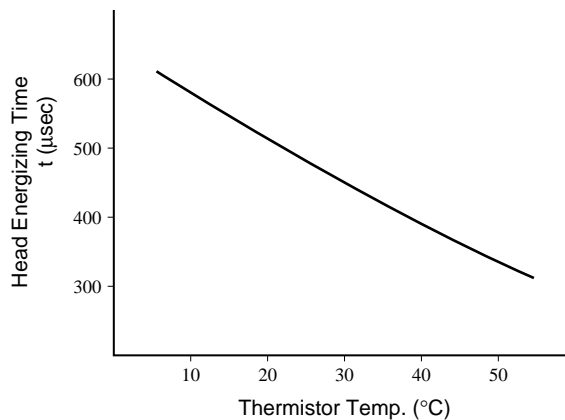
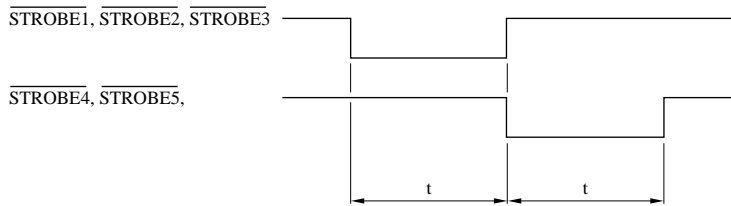

Fig. 2-7 Head Energizing Control

THEORY OF OPERATION

2-3. Feed-Motor Drive Circuit

The printer employs a 4-phase step motor (phase 1-2 excitation) to implement paper feed. The motor rotates through a certain angle each time it receives a pulse from the drive circuit. The following diagram illustrates the phase 1-2 excitation method. Diagram 2-8 shows the feed-motor drive circuit.

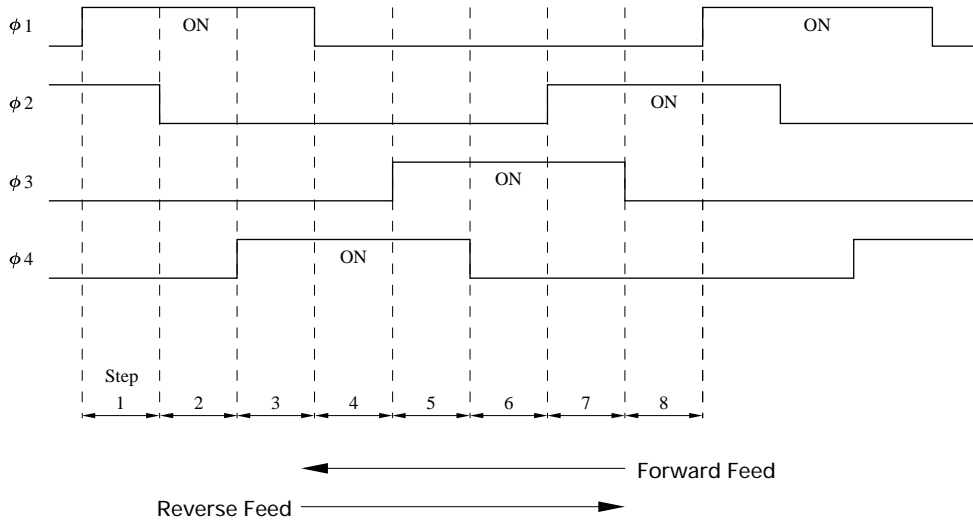

Fig. 2-8 Motor Control by Phase 1-2 Excitation

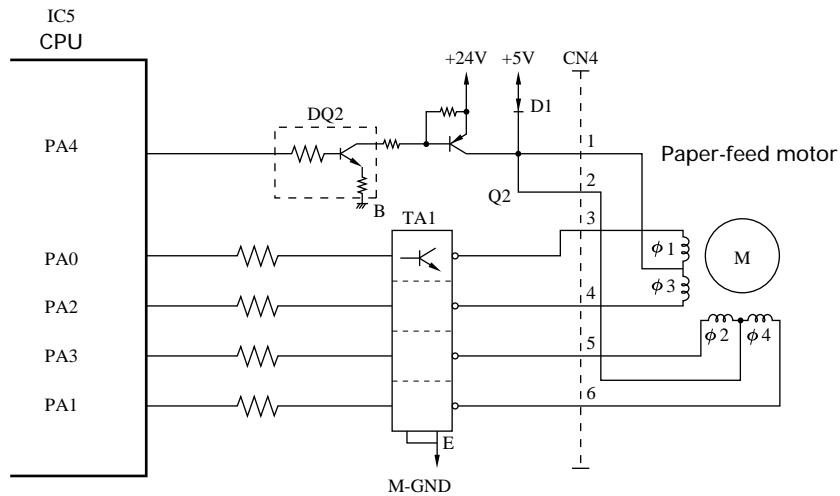

Fig. 2-9 Feed-Motor Drive Circuit

Voltage to the motor is controlled to produce the required action, as follows.

Mode	Voltage	Action
Operating	VM (+24V) VL (+5V)	Drives the motor
Idle	VL (+5V)	Holds the motor

Voltage is controlled by PA4 of the CPU, which goes HIGH or LOW to switch transistors DQ2 and Q2 ON or OFF. When Q2 is ON, the motor receives +24V (VM). When Q2 is OFF, +5V is supplied to the motor via diode D1.

2-4. Power-On Reset Circuit

Immediately following power-on the printer executes a power-on reset, initializing all circuit elements. The power-on reset serves as protection against operational errors. The power-on RESET signal is maintained for approximately 160ms. The reset circuit is illustrated below.

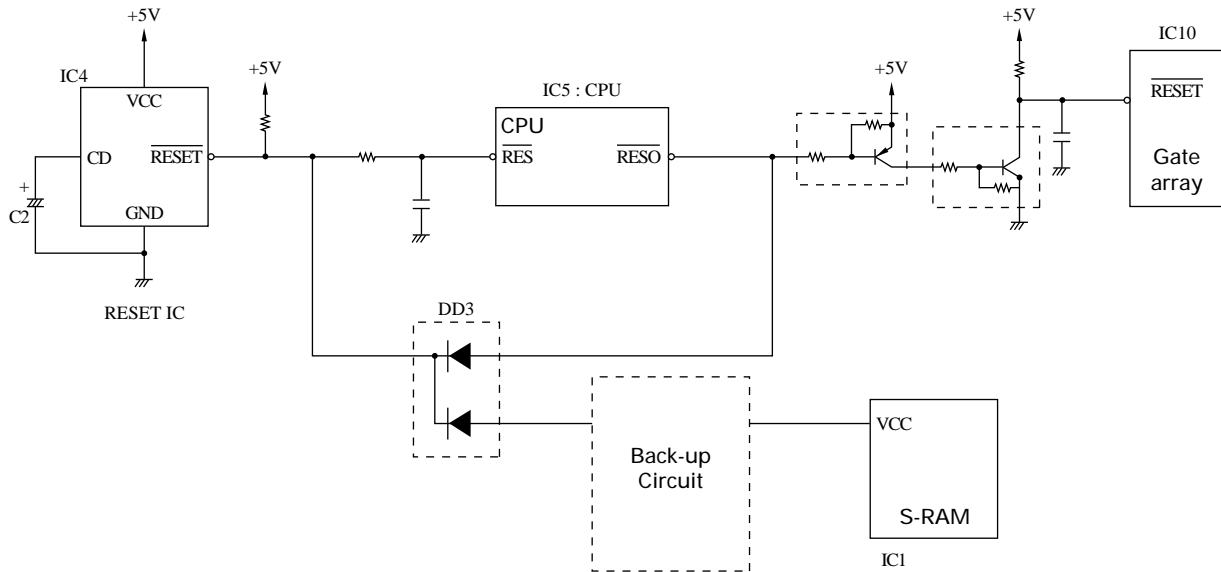

Fig. 2-10 Power-On Reset Circuit

- 1 At power on, voltage-detector circuit IC4 (M51953BL) outputs a LOW signal from its OUT terminal. The signal lasts for approximately 160ms, as determined by capacitor C2 (0.47μF):

$$T = 0.34 \times C2 \text{ (pF)} \text{ [}\mu\text{s]} = 160\text{ms}$$

- 2 The LOW signal resets the CPU and the mechanism drive circuits, and sets S-RAM into backup state.

THEORY OF OPERATION

2-5. +5V Line Voltage Detector Circuit

The voltage-detection IC (IC4 in Fig. 2-10) detects momentary drops or unstable levels in the +5V line voltage. IC4 operation is illustrated by the equivalence circuit shown below.

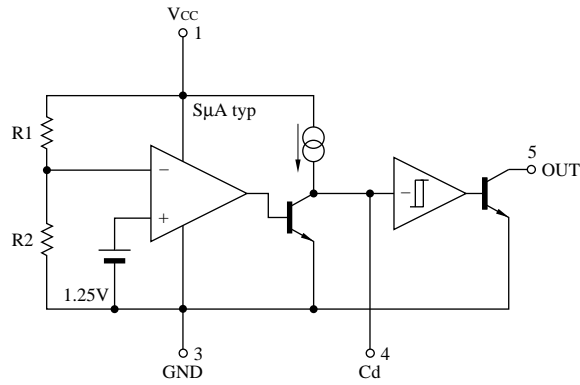

Fig. 2-11 Equivalence Circuit for Voltage Detecting IC

Fig. 2-11 shows the operational timing. If the +5V line voltage falls below 4.25V, the IC produces a reset signal at its OUTPUT terminal, resetting the CPU and the gate array.

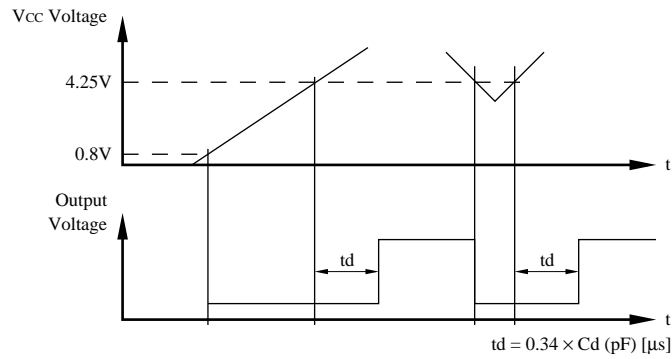

Fig. 2-12 Operation Timing Chart

3. Printer Mechanism

3-1. Thermal Head

The TSP400 printers employ thermal line printing. The thermal head consists of a horizontal line of 640 heat elements. These elements print one line of dots at a time as the paper passes over the head. The head is fixed in position; only the paper moves.

The printer prints a dot by heating the corresponding heat element. The heated element causes a chemical reaction in the coloring layer of the thermal paper, resulting in the formation of a visible dot.

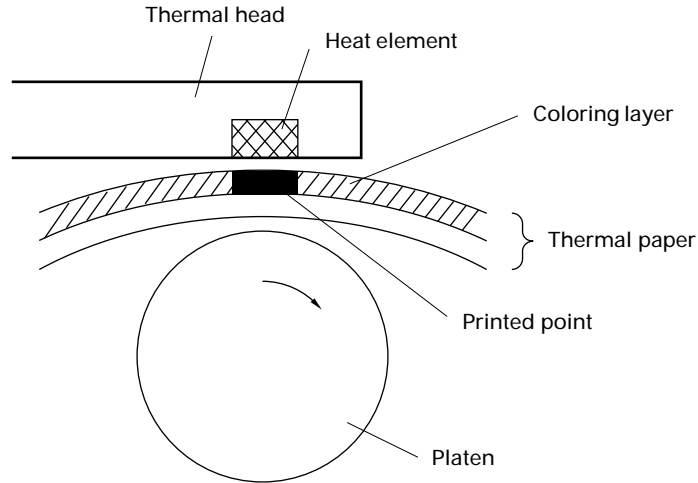

Fig. 2-13 Principle of Thermal Printing

3-2. Paper-Feed Mechanism

The paper-feed mechanism is comprised of the paper-feed motor, gear train, platen, and thermal head. The paper-feed motor drives the gear train, which in turn rotates the platen. The platen carries the thermal paper past the thermal head.

The paper-feed motor is a PM (permanent magnet) type, 4-phase 48-pole step motor. A single step feeds the paper approximately 0.125mm.

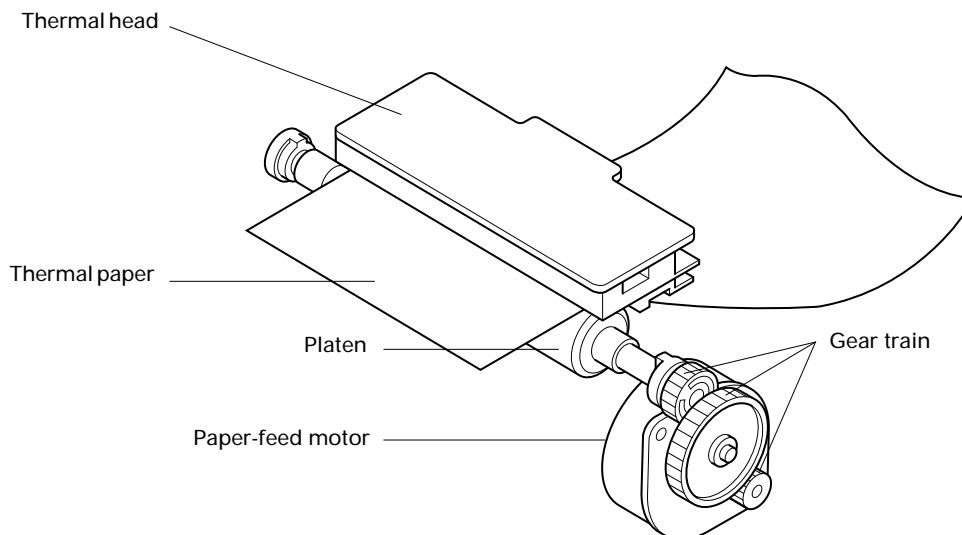

Fig. 2-14 Paper-Feed Mechanism

THEORY OF OPERATION

3-3. Detectors

(1) Paper-Out Detector

The paper-out detector is located at the paper entry slit. The detector consists of a reflective photosensor. The photosensor's phototransistor remains ON while paper is present. It goes OFF when paper runs out, generating output of a paper-out signal.

(2) Black-Mark Detector

This detector senses black marks indicating print start positions. The detector is useful only with specially marked paper. Like the paper-out detector, the black-mark detector consists of a reflective photosensor. The photosensor's phototransistor goes OFF when a black mark appears.

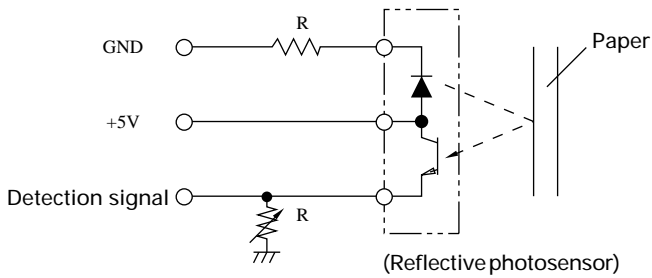

Fig. 2-15 Paper-Out Detector

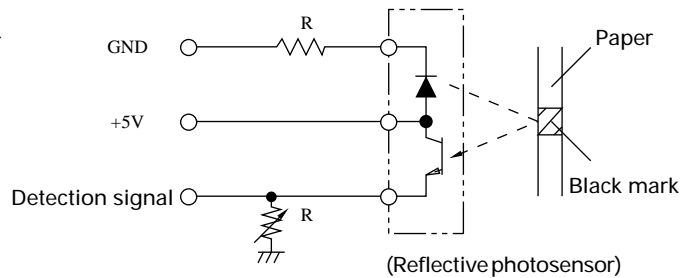

Fig. 2-16 Black-Mark Detector

(3) Label Detector

The transmissive detector is used to detect print-start positions for labels. It operates by detecting the difference in light transmission between backing-only and backing-plus-label portions of the paper.

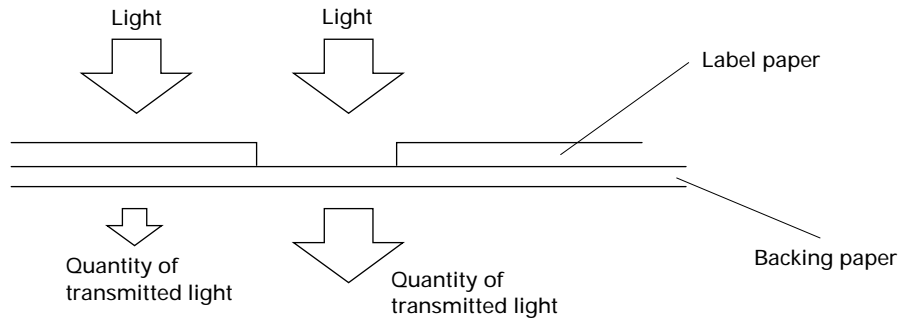

Fig. 2-17

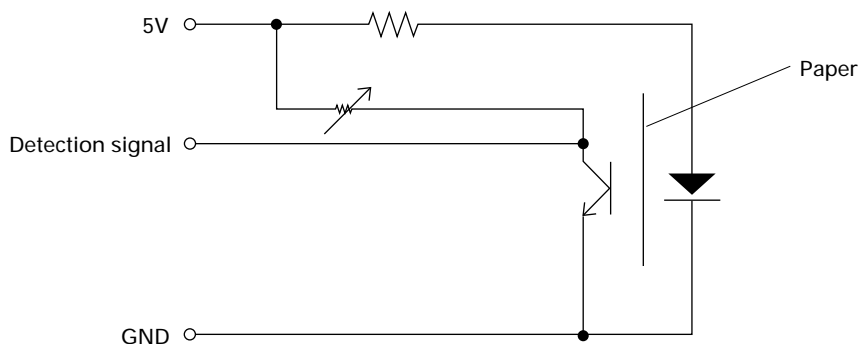

Fig. 2-18 Label Detector

(4) Head-Up Detector

This detector consists of a leaf switch indicating whether the head is closed (in contact with the platen) or open (separated from the platen). The leaf switch is closed when the head is closed; it opens when the head is opened.

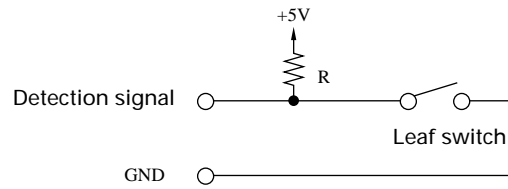

Fig. 2-19 Head-Up Detector

CHAPTER 3

PARTS REPLACEMENT AND RELATED ADJUSTMENTS

This chapter describes disassembly and reassembly procedures.

Please take note of the following.

1. ALWAYS disconnect the power cord from the AC outlet before beginning a disassembly or reassembly procedure.
2. Except where otherwise stated, the reassembly procedure is the reverse of the disassembly procedure.
3. Coat screw heads with locking sealant after completion of reassembly.
4. Refer to Chapter 4 Section 2 for important information about lubrication requirements.

Note : The printer has no adjustable parts.

1. Upper Casing Unit	35
2. Control-Panel Board	36
3. Printer Mechanism	37
4. Main PCB, Interface PCB	38
5. Power Unit	39
6. Fuse	39
7. Printhead Unit.....	40
8. Feed Motor Assembly	40
9. Detectors	41
10. Label sensor	41

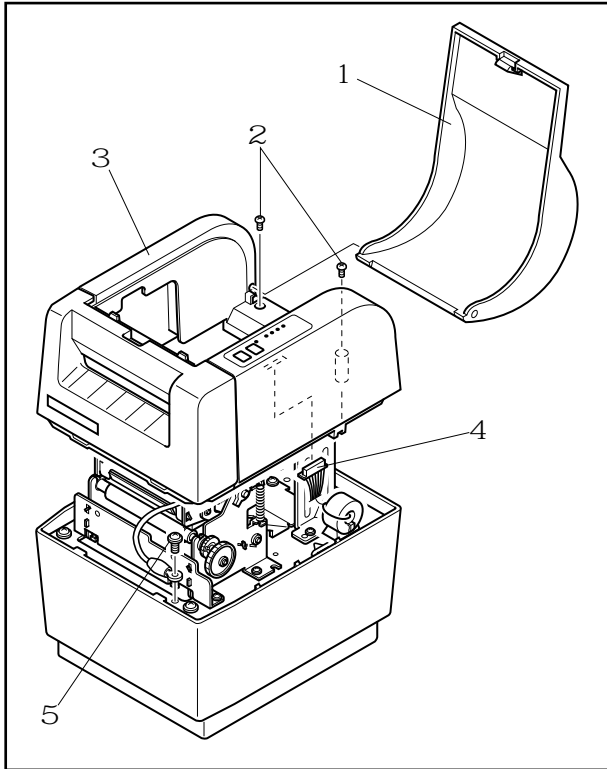

1. Upper Casing Unit

<TSP412D>

- (1) Disconnect the power cord from the AC outlet.
- (2) Remove:
 - Upper cover 1
 - Two tapping screws 2
 - Upper casing unit 3
 - Pull forward and remove.
 - Connector 4
 - Screw 5

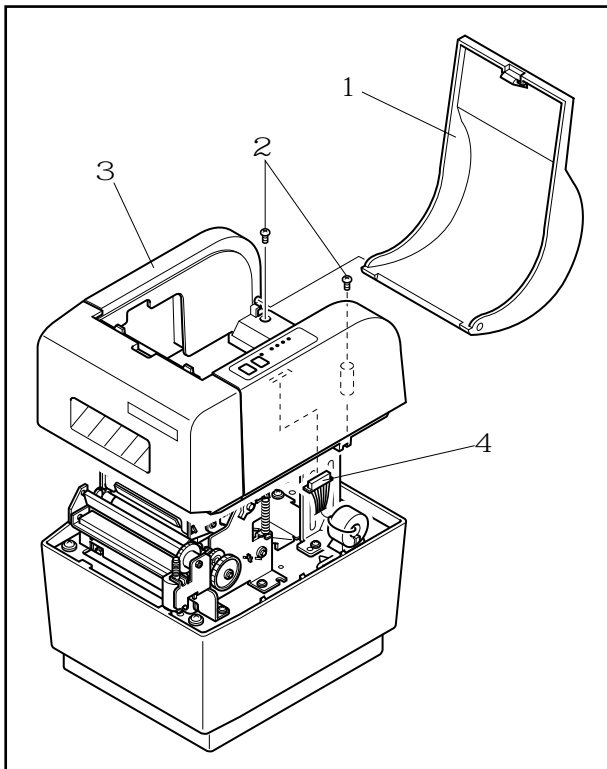

<TSP442D>

- (1) Disconnect the power cord from the AC outlet.
- (2) Remove:
 - Upper cover 1
 - Two tapping screws 2
 - Upper casing unit 3
 - Pull forward and remove.
 - Connector 4

PARTS REPLACEMENT

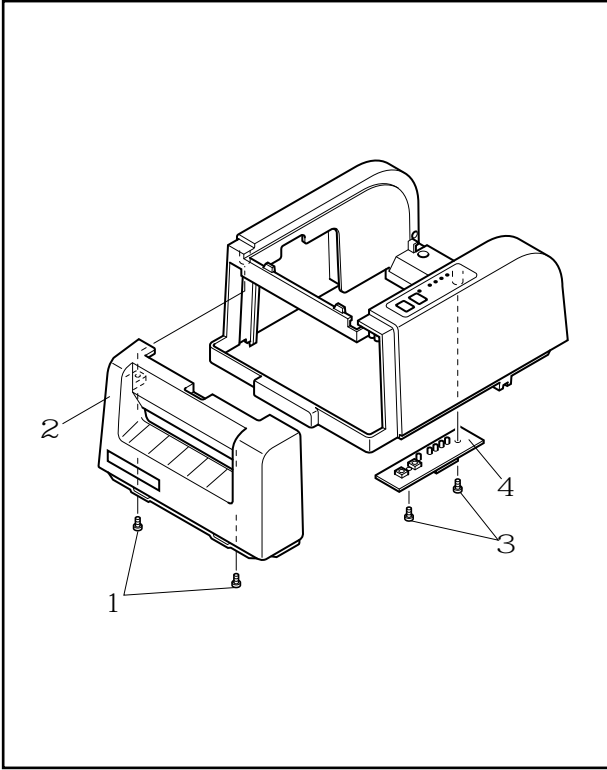

2. Control-Panel Board

(1) Remove:

- Upper casing unit (See 1. above.)
- Two tapping screws 1
- Front cover 2
- Two tapping screws 3
- Control-panel board 4

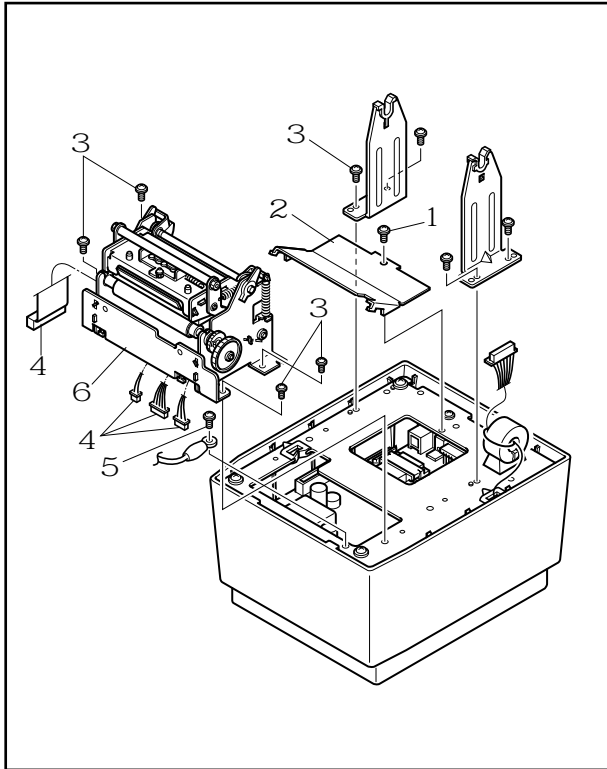

3. Printer Mechanism

<TSP412D>

- (1) Remove:
- Upper casing unit (See 1. above.)
 - One tapping screw 1
 - ROM cover 2
 - Eight tapping screws 3
 - Four connectors 4
 - Screw 5
 - Printer mechanism 6

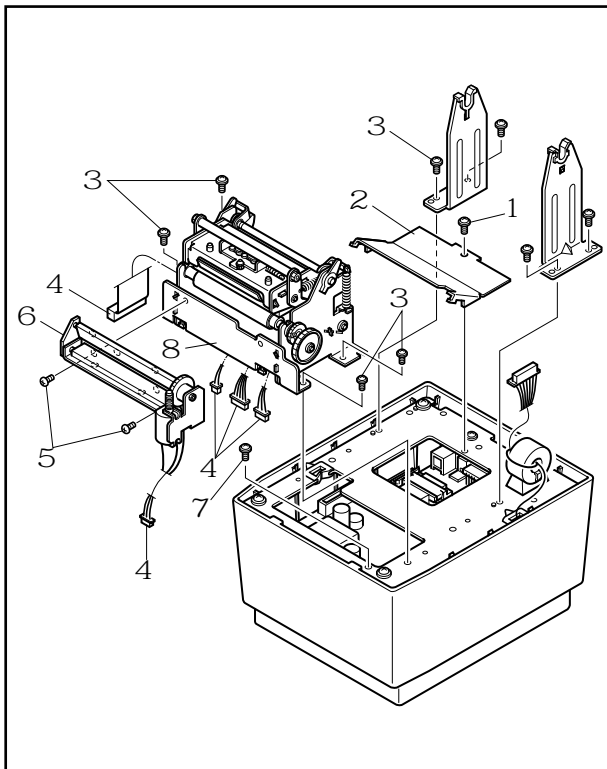

<TSP442D>

- (1) Remove:
- Upper casing unit (See 1. above.)
 - One tapping screw 1
 - ROM cover 2
 - Eight tapping screws 3
 - Five connectors 4
 - Two tapping screws 5
 - Cutter unit 6
 - Screw 7
 - Printer mechanism 8

PARTS REPLACEMENT

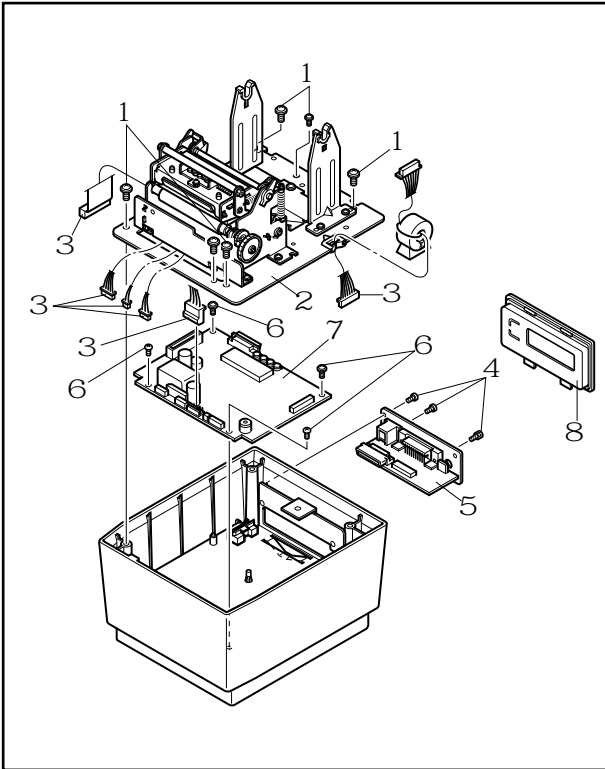

4. Main PCB, Interface PCB

<TSP412D>

(1) Remove:

- Upper casing unit (See 1. above.)
- Six tapping screws 1
- Mechanism chassis 2
- Six connectors 3
- Interface cover 8
- Three screws 4
- Interface PCB 5
- Four screws 6
- Main PCB 7

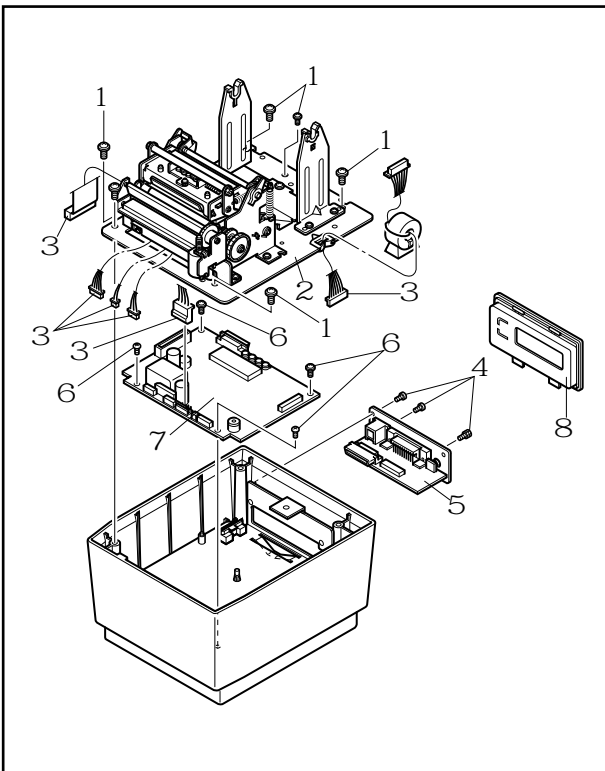

<TSP442D>

(1) Remove:

- Upper casing unit (See 1. above.)
- 1 screw
- Four tapping screws 1
- Mechanism chassis 2
- Seven connectors 3
- Interface cover 8
- Three screws 4
- Interface PCB 5
- Four screws 6
- Main PCB 7

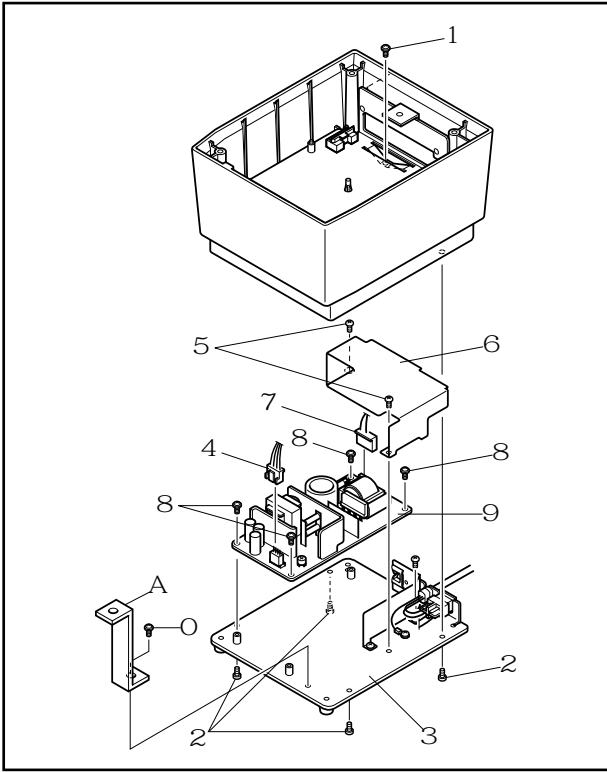

5. Power Unit

- (1) Disconnect the power cord from the AC outlet.
- (2) Remove:
 - Upper casing unit (See 1. above.)
 - Three screws (See 4. above.)
 - Interface PCB (See 4. above.)
 - Screw 1
 - Four screws 2
 - Lower casing chassis 3
 - Connector 4
 - Two tapping screws 5
 - Shield chassis (A) 6
 - Connector 7
 - Four screws 8
 - Power unit 9
 - Screw O
 - Earth plate (A) A

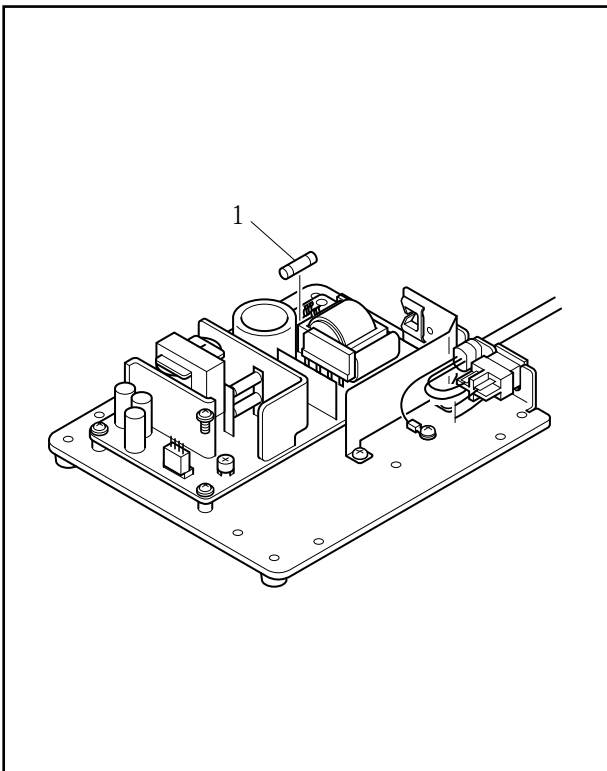

6. Fuse

- (1) Remove shield chassis A, according to procedure given in 5. above.
- (2) Check fuse F1. 1
If the fuse is blown, replace with the following.

AC Voltage	F1
120V	5TT5A-125V
220-240V	EAK3.15A250V

If the replacement fuse also blows out, replace the power unit or check the main logic board.

PARTS REPLACEMENT

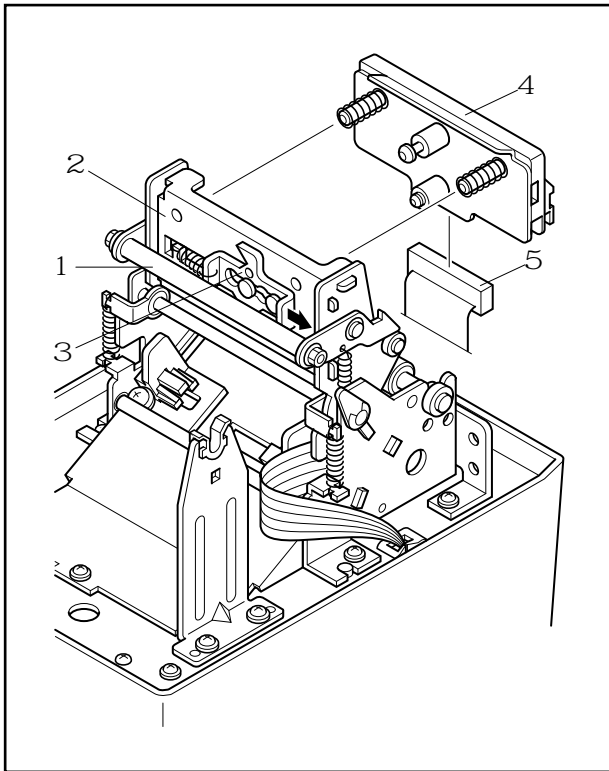

7. Printhead unit

- (1) Remove the upper casing unit. (See 1. above.)
- (2) Pull the pressure stay 1 forward to open the head frame unit 2 .
- (3) Slide the head clamp 3 in the direction indicated by the arrow. Remove the printhead unit 4 .
- (4) Remove the head connector 5 .

Note : Be careful to avoid damaging the heat elements when installing the replacement unit.

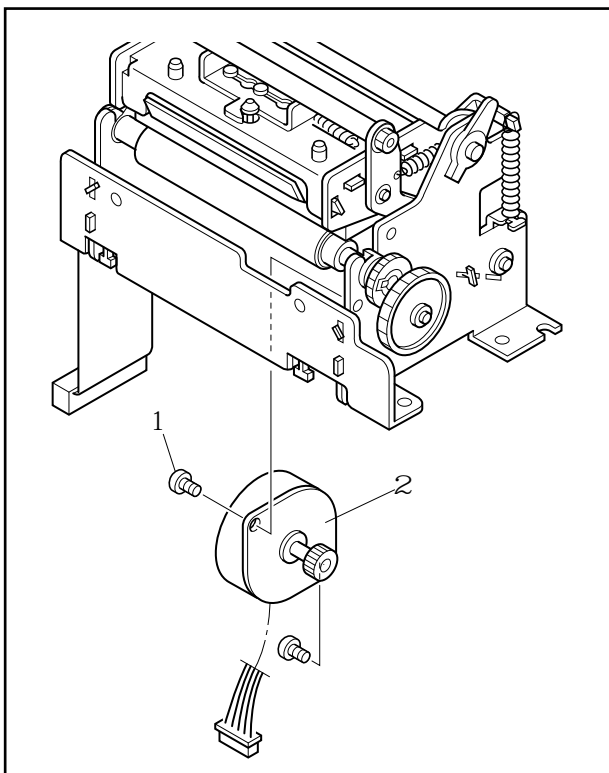

8. Feed Motor Assembly

- (1) Remove:
 - Printer mechanism (See 3. above.)
 - Two tapping screws 1
 - Feed motor assembly 2

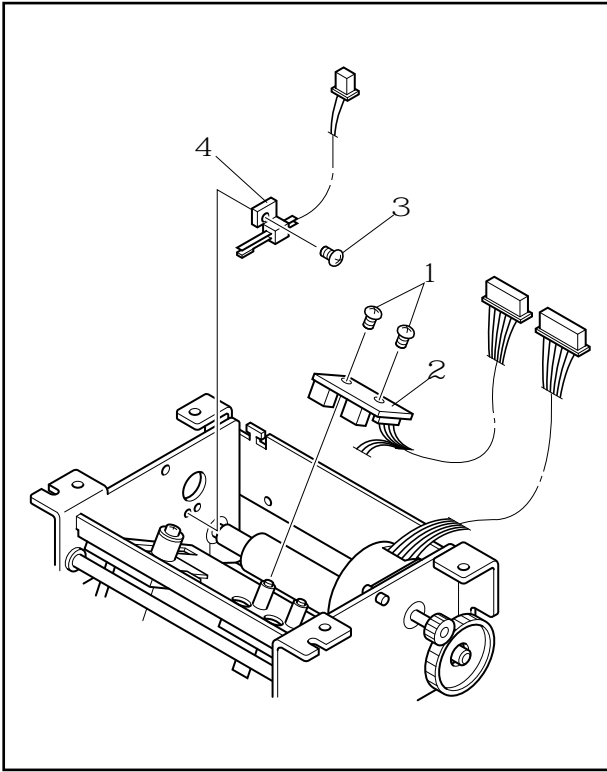

9. Detectors

- (1) Remove:
- Printer mechanism (See 3. above.)
 - Two screws 1
 - Paper-out and black-mark detectors 2
 - Tapping screw 3
 - Head-up detector 4

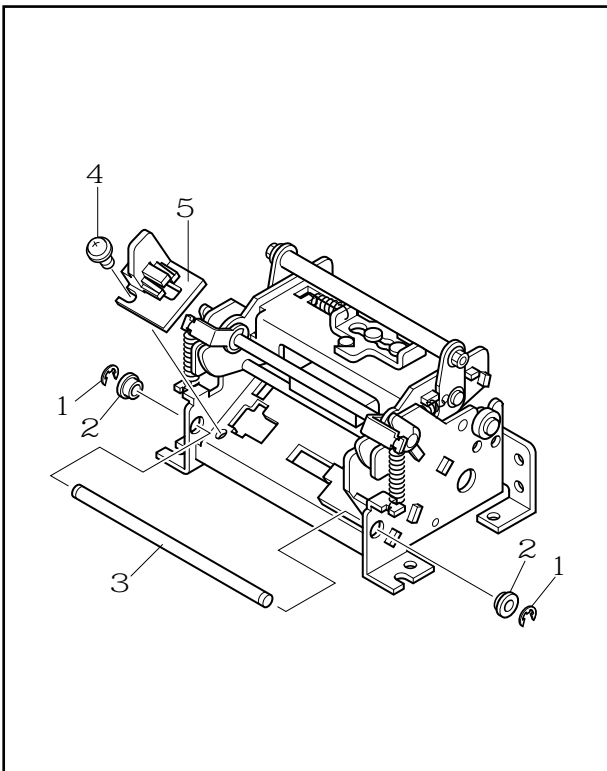

10. Label sensor

- (1) Remove:
- Two E-rings 1
 - Two oilless bushings 2
 - Support stay 3
 - One tapping screw 4
 - Label sensor 5

CHAPTER 4

MAINTENANCE AND LUBRICATION

1. Maintenance	45
1-1. Cleaning	45
1-2. Checks	45
2. Lubrication	46
2-1. Lubricants	46
2-2. Application Method	46
2-3. Lubrication Points	46

1. Maintenance

Proper maintenance is necessary to maintain printer performance and forestall potential problems. Please carry out maintenance as described below.

1-1. Cleaning

(1) Surface dirt

Clear away dirt with a soft cloth. If necessary, apply a small quantity of alcohol to the cloth to improve cleaning power. NEVER use thinner, trichlene, or ketone solvents, as these can cause damage to plastic components.

When cleaning, take care to avoid damaging or moistening of electronic parts, mechanical parts, and wires.

(2) Internal dust

For best results, use an electric vacuum cleaning device to remove dust from the inside of the printer. Note that such cleaning may also remove lubrication; when you have finished cleaning, check lubrication levels and apply lubricant as necessary.

1-2. Checks

There are two types of maintenance checks. Simple “daily checks” can be performed by users during the course of daily operation. “Periodic checks” must be carried out by qualified service personnel.

(1) Daily checks

- Check whether dirt or other foreign matter has worked its way into the printer, and remove as necessary.
- Check the thermal head for excessive dirt. If the head is very dirty, clean it with a cotton stick or a soft cloth soaked in alcohol.

(2) Periodic checks

Periodic checks and lubrication should be carried out once every six months or once every million lines of printing.

- Check the integrity of springs.
- Clear dust from areas around the detectors.

MAINTENANCE AND LUBRICATION

2. Lubrication

Proper lubrication is essential for maintaining the printer's performance level and preventing breakdowns or other problems.

2-1. Lubricants

Choice of lubrication can significantly affect the printer's performance, longevity, and low-temperature characteristics. We recommend the following lubricant for the TSP400 series.

Type	Name	Manufacturer
Grease	Molykote EM	Dow Corning

2-2. Application Method

If you are lubricating parts during disassembly or reassembly, be sure to wash or wipe the parts thoroughly to remove all dirt and dust prior to lubricating.

Remember that cleaning can remove necessary lubrication. Always lubricate after cleaning, disassembly, or replacement.

2-3. Lubrication Points

Apply lubricants at the following locations. (Refer to Diagram 4-1.)

No.	Location
1	Contact area of pressure bar and pressure pin
2	Contact area of gear 15×50×0.5 and gear shaft
3	Contact area of gear 58×0.5 and gear shaft
4	Contact area of gear 15×50×0.5 and PF motor gear
5	Contact area of gear 58×0.5 and platen gear
6	Contact area of head stay and head base frame
7	Contact area of head clamp and clamp pin
8	Contact area of head clamp and head stay R
9	Contact area of lever and lever shaft (TSP442)

Note 1 : Paper debris on cutter blade can cause paper jams. Clean away debris by wiping with alcohol, then reapply lubricant.

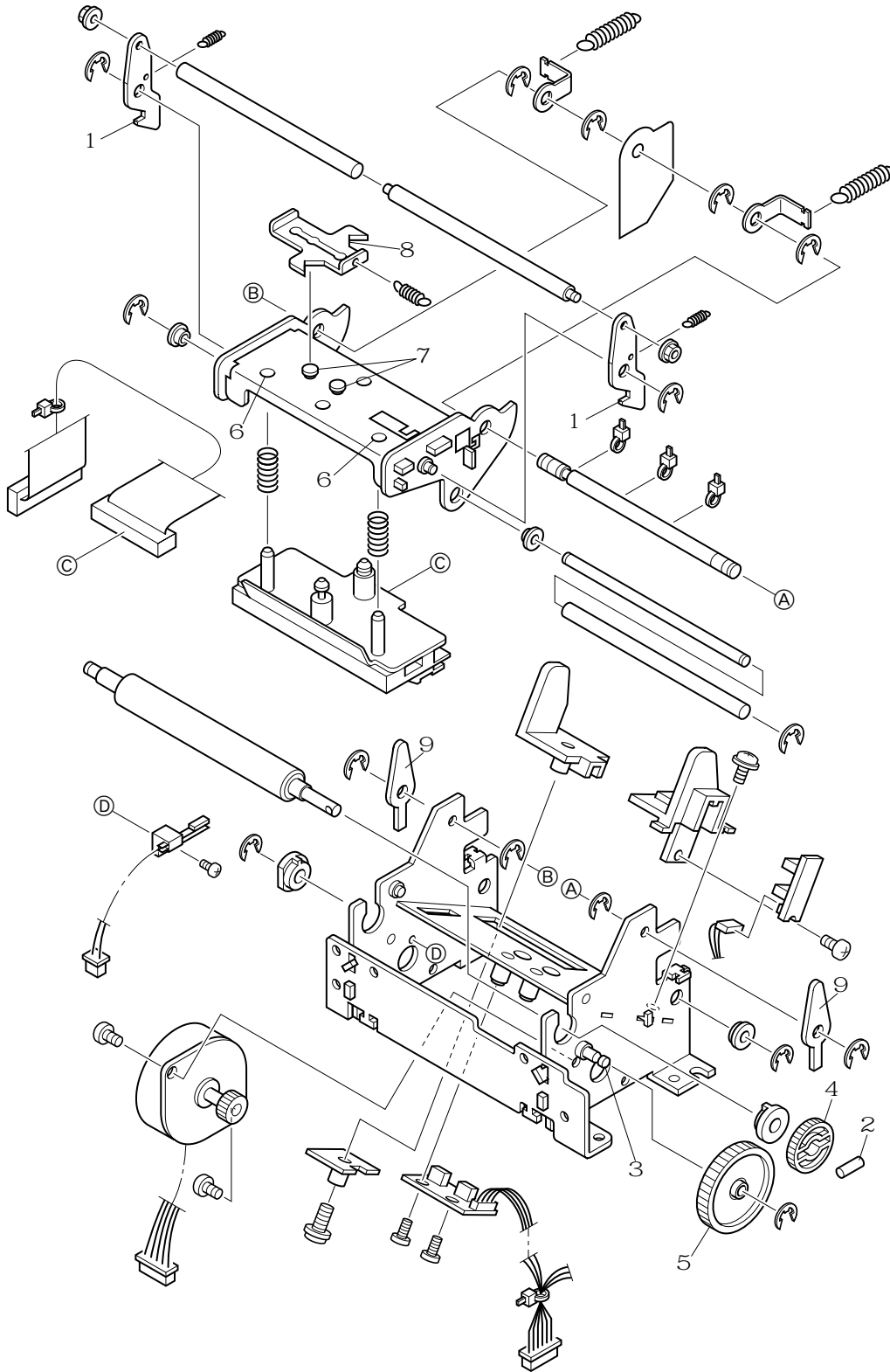

Fig. 4-1 Lubrication Points

CHAPTER 5 PARTS LIST

READING THE LISTS

- (1) **DRWG. NO.**
Corresponds to the drawing number or to the silk-screened number on the board to which the part is mounted.
- (2) **REVISED EDITON MARK**
This column shows a revision number.
Parts that have been added in the revised edition are indicated with “#”.
Parts that have been abolished in the revised edition are indicated with “*”.
#1 : First edition → Second edition #2 : Second edition → Third edition
*1 : First edition → Second edition *2 : Second edition → Third edition
- (3) **PART NO.**
Part identification number. Always indicate this number clearly when ordering a part.
Parts described as “NPN” have no parts number and are not in stock, i.e., unavailable.
- (4) **PART NAME**
Name of part. Always include the name (as well as the part No.) when ordering the part.
- (5) **QTY**
Indicates the number of units of the part used within the assembly.
- (6) **REMARKS**
This column is used for general comments. It also indicates EPROM seal numbers. A “*” within a seal number indicates the version number.
- (7) **RANK**
“S” indicates that the part is a “service part” that should always be kept in stock for maintenance purposes.

1. Printer Assembly 50 1-1. Disassembly Drawing 50 A. TSP412D 50 B. TSP442D 51 1-2. Parts List 52 2. Printer Mechanism Assembly 54 2-1. Disassembly Drawing 54 2-2. Parts List 55 3. Connector Wiring Diagram 56 A. RS-232C Interface Type 56 B. RS-422A Interface Type 57 C. Parallel Interface Type 58 4. Main Logic Board 59 4-1. Circuit Diagram 59 4-2. Parts List 63 5. RS232C Interface Board 66 5-1. Circuit Diagram 66 5-2. Parts List 67	6. RS422A Interface Board 68 6-1. Circuit Diagram 68 6-2. Parts List 69 7. Centronics Interface Board 70 7-1. Circuit Diagram 70 7-2. Parts List 71 8. Control Panel Board 72 8-1. Circuit Diagram 72 8-2. Parts List 73 9. Paper-Out Detector Board 74 9-1. Circuit Diagram 74 9-2. Parts List 74 10. Label Sensor Board 74 10-1. Circuit Diagram 74 10-2. Parts List 74
--	--

B. TSP442D

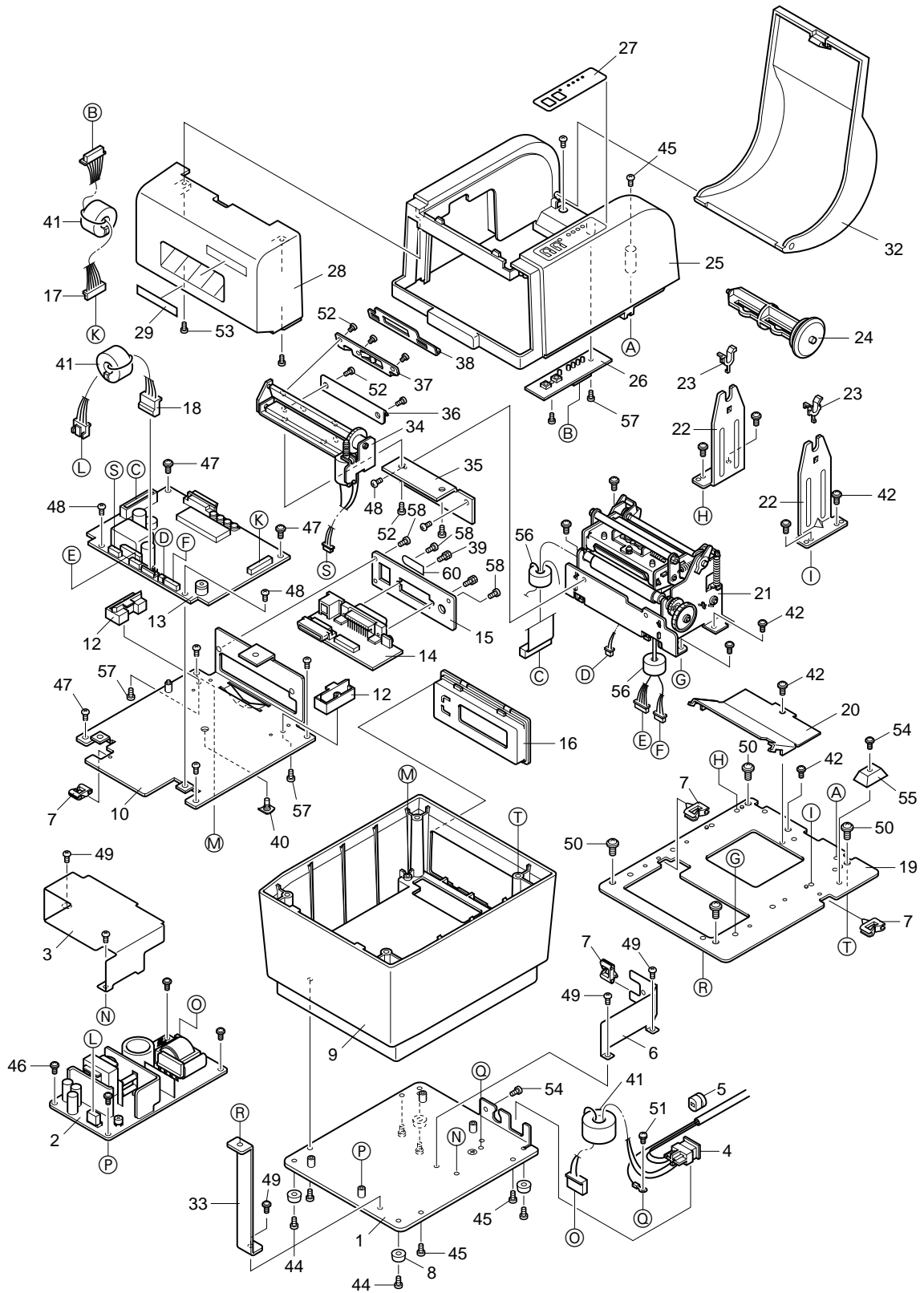

1-2. Parts List

Printer Assembly

DRWG.NO.	REV.	PARTS NO.	PARTS NAME	Q'TY	REMARKS	RANK
1		87391070	LOWER CASE CHASSIS UNIT BCP4	1		
2		87393030	POWER SUPPLY UNIT SLS-060P-50	1	US	S
		87393090	POWER SUPPLY UNIT SLS060PH-50A	1	EC,UK	S
3		82011481	SHIELD CHASSIS A BCP4	1		
4		87393040	CORD SET UNIT US BCP4	1	US	S
		87393070	CORD SET UNIT EC BCP4	1	EC	S
		87393080	CORD SET UNIT UK BCP4	1	UK	S
5		04991220	CORD BUSHING SR-5N-4	1		
6		82011490	SHIELD CHASSIS B BCP4	1		
7		04991254	CORD CLAMP EDS-1208U	4		S
8		80991601	RUBBER FOOT 8340	4		S
9		87391080	LOWER CASE UNIT BCP4	1		
10		NPN	BOARD CHASSIS TSP4	1		
12		33750010	BOARD RAIL TSP4	2		
13		37407000	MAIN LOGIC BOARD UNIT TSP4	1		S
14	*2	37403800	IF PLATE RS232 UNIT TSP4	1	RS232C	S
	#2	37407800	RS232C IF BOARD UNIT TSP4	1	RS232C	S
		37407810	RS422 IF BOARD UNIT TSP4	1	RS422A	S
		37407820	PARALLEL IF BOARD UNIT TSP4	1	PARALLEL	S
15		32021010	SERIAL IF PLATE TSP4	1	RS232C,RS422A	
		32021110	PARALLEL IF PLATE TSP4	1	PARALLEL	
16		33020200	INTERFACE COVER TSP4	1		
17		30721030	CABLE UNIT 12X220CC TSP4	1		
18		30721021	CABLE UNIT B TSP4	1	EC,UK	
		30721040	CABLE UNIT A TSP4	1	US	
19		32010211	MECHANISM BASE CHASSIS TSP4	1		
20	*2	32912010	ROM COVER TSP4	1		
	#2	32912011	ROM COVER TSP4	1		
21		38405000	TMP412-24	1		S
22		32041010	HOLDER ANGLE TSP4	2		
23		83201000	ROLL PAPER BUSHING BMP4	2		S
24		83903931	LABEL HOLDER 3.25 BMP4	1	ACCESSORY	S
25		83025392	UPPER CASE BCP4	2		
26		87390610	CONTROL PANEL BOARD ASSY BCP4	1		S
27		30061010	OPERATION SHEET TSP4	1		
28		83025420	FRONT COVER A BCP4	1	TSP412	
		83025481	FRONT COVER B BCP4	1	TSP442	
29		30071010	BRAND SEAL TSP4	1		
30		82902290	CUTTER BCP4	1	TSP412	S
31		80701770	WIRE 18UL1007BRN145TT	1	TSP412	
32		33020210	UPPER COVER B TSP4	1		S
33		32790000	EARTH PLATE A TSP4	1		
34		80040151	CUTTER 4010 BCP4	1	TSP442	S
35		82902430	CUTTER HOLDER BCP4	1	TSP442	
36		82040621	CUTTER PAPER GUIDE B BCP4	1	TSP442	
37		82902460	PAPER GUIDE CLAMP BCP6	1	TSP442	
38		82040611	CUTTER PAPER GUIDE A BCP4	1	TSP442	
39		04991401	SCREW DBLC-J25SAF	2	RS232C,RS422A	S
40		09990527	BOARD SPACER RSPS-8L	1		S
41		09990723	FERRITE CORE TFC-23-11-14	2	US	
		09990723	FERRITE CORE TFC-23-11-14	3	EC,UK	
42		01903077	SCREW TAT 3-5 CT-FL	10	TSP412	S
		01903077	SCREW TAT 3-5 CT-FL	11	TSP442	S
43		00930605	SCREW TAT 3-6 FS	2		S
44		00930609	SCREW TAT 3-6 CT	4		S

Printer Assembly

DRWG.NO.	REV.	PARTS NO.	PARTS NAME	Q'TY	REMARKS	RANK
45		00930803	SCREW TAT 3-8 PT	6		S
46		01903018	SCREW TR 3-6 WS/WF	4		S
47		01903059	SCREW TR 3-5 FL	6		S
48		01903069	SCREW TAT 3-5 ST-FL	2	TSP412	S
		01903069	SCREW TAT 3-5 ST-FL	4	TSP442	S
49		01903099	SCREW TR 3-4 WS	5		S
50		01914035	SCREW TAT 4-10 PT-FL	4		S
51		01914036	SCREW TR 4-5 WS	1		S
52		00630404	SCREW TR 3-4	7	TSP442	S
53		00930803	SCREW TAT 3-8 PT	2		S
54	#1	00930500	SCREW TAT 3-5 ST	2		S
55	#1	04991257	CORE STOPPER TFP2014-V	1		
56	#2	09990713	FERRITE CORE TRCC-16-8-16 CASE	2	EC,UK	
57	#2	00930603	SCREW TAT 3-6 PT	6	TSP412	S
	#2	00930603	SCREW TAT 3-6 PT	4	TSP442	S
58	#2	00630504	SCREW TR 3-5	3		S
59	#2	01903085	SCREW TAT 3-7 WS	1	TSP412	S
60	#2	30091010	TENSION SHEET	TSP2		
-	#2	09990723	FERRITE CORE TFC-23-11-14	1	ACCESSORY	:EC
	#2	09990728	FERRITE CORE TFC-20-10-10	1	ACCESSORY	:EC
	#2	04991204	FASTENER T18S	1	ACCESSORY	:EC

2. Printer Mechanism Assembly

2-1. Disassembly Drawing

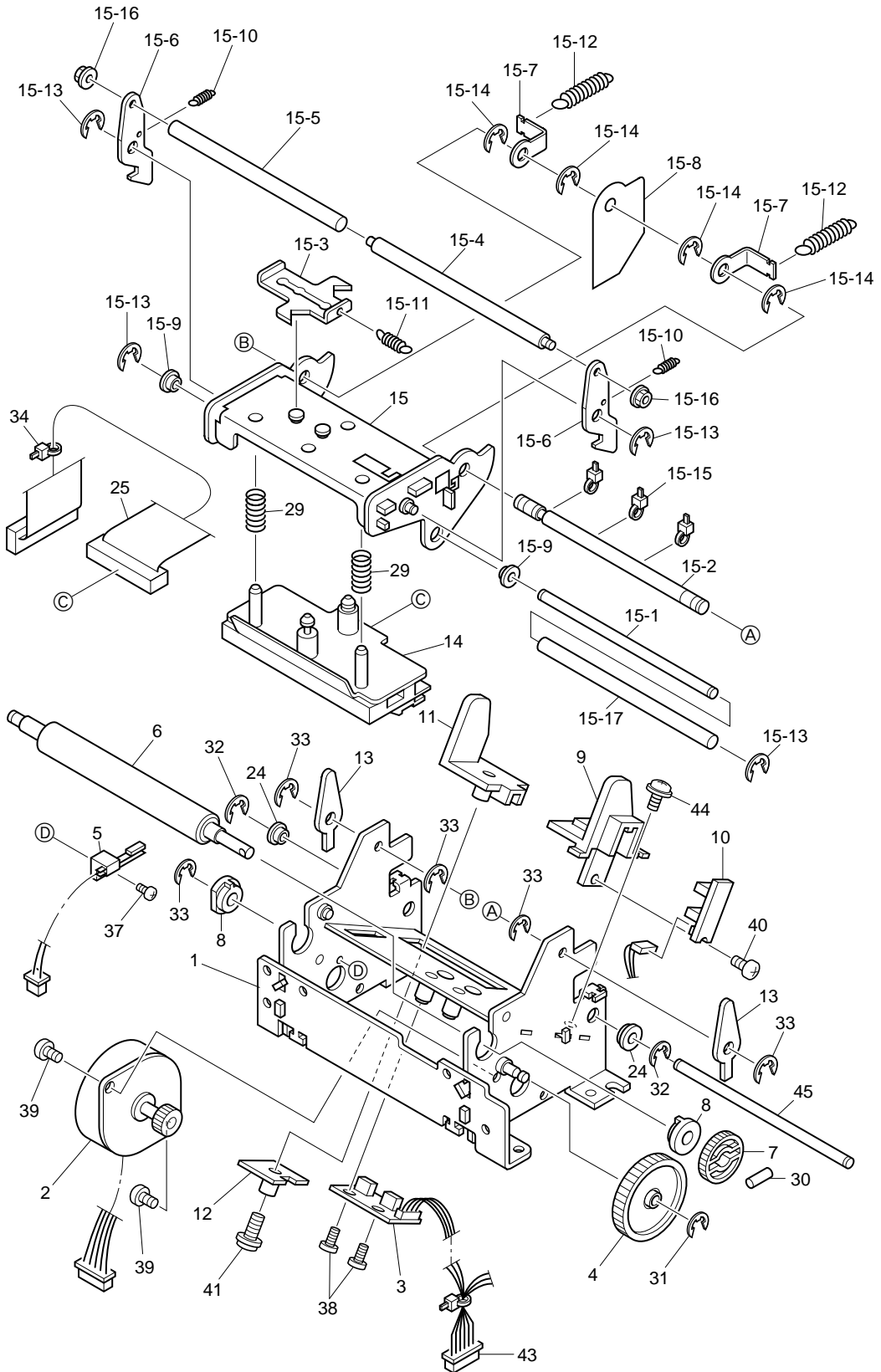

2-2. Parts List

Printer Mechanism

DRWG.NO.	REV.	PARTS NO.	PARTS NAME	Q'TY	REMARKS	RANK
1		NPN	FRAME ASSY	1		
2		37412300	PF MOTOR ASSY	TMP4	1	S
3		37417000	REFLECT SENSOR BD UNIT	TMP4	1	S
4		83100460	IDLER GEAR 15X50X0.5		1	S
5		87340390	HEAD DETECTOR ASSY	BMP8	1	S
6	*2	31375210	PLATEN	TMP4	1	S
	#2	31375211	PLATEN	TMP4	1	S
7		33102210	GEAR 28X0.5	TMP4	1	S
8		80203041	DRIVE SHAFT BEARING	MP300	2	S
9		33910020	PAPER GUIDE A	TMP4	1	S
10		37417010	TRANSMIT SENSOR BD UNIT	TMP4	1	S
11	*1	33910030	PAPER GUIDE B	TMP4	1	S
	#1	33910031	PAPER GUIDE B	TMP4	1	S
12		33903010	FRICTION PLATE	TMP4	1	S
13		33490010	HEAD POSITION LEVER	TSP4	2	
14	*1	87343110	HEAD UNIT	BMP4	1	S
	#1	37419000	HEAD UNIT	TMP4	1	S
15	*1	87340410	HEAD FRAME UNIT	BMP4	1	
	#1	37410010	HEAD FRAME UNIT	TMP4	1	
15-1		81360850	PAPER GUIDE ROLLER	BMP4	1	
15-2		31303010	HEAD UNIT PIVOT SHAFT	TSP4	1	
15-3		82902330	HEAD CLAMP	BMP4	1	
15-4		81370910	PRESSURE STAY	BMP4	1	
15-5		09991391	HEAT-SHRINK TUBE A-6.0 GRN		1	
15-6		82401370	PRESSURE LEVER	BMP4	2	
15-7		82401360	HEAD STOPPER LEVER	BMP4	2	
15-8		80994252	GUARD SHEET	BMP4	1	
15-9		04310401	OILESS BUSHING F4X7X3		2	
15-10		80511070	SPRING E040-040-0159		2	S
15-11		80510840	SPRING E055-060-0180		1	S
15-12	*1	80511060	SPRING E060-060-0316		2	S
	#1	30510410	SPRING E065-070-0238		2	S
15-13		04020015	STOP RING SE3.0		2	S
15-14		04020016	STOP RING SE4.0		2	S
15-15		04991204	FASTENER T18S		3	S
15-16		02040301	FLANGED NUT NHW3		2	S
15-17		09991372	HEAT-SHRINK TUBE 4.0		1	S
25	*1	80705030	CABLE UNIT 26X265CC	BMP4	1	
	#1	80705031	CABLE UNIT 26X290CC	BMP4	1	
29	*1	80520950	SPRING C075-080-0187		2	S
	#1	30520210	SPRING C075-080-0165		2	S
30		04012003	ROLL PIN SP2.0X8		1	S
31		04020010	STOP RING SE2.0		1	S
32		04020015	STOP RING SE3.0		2	
33		04020016	STOP RING SE4.0		7	
34		04991204	FASTENER T18S		2	
37		00920503	SCREW TAT 2-5 CT		1	S
38		00630404	SCREW TR 3-4		2	
39		00930403	SCREW TAT 3-4 CT		2	
40		00930803	SCREW TAT 3-8 PT		1	
41		01914035	SCREW TAT 4-10 PT-FL		1	
42		00930609	SCREW TAT 3-6 CT		1	
43		30721010	CABLE UNIT	TMP4	1	
44	#1	01903090	SCREW TAT 3-8 CT-FL		1	
45	#1	31361010	SUPPORT STAY	TMP4	1	

3. Connector Wiring Diagram

A. RS-232C Interface Type

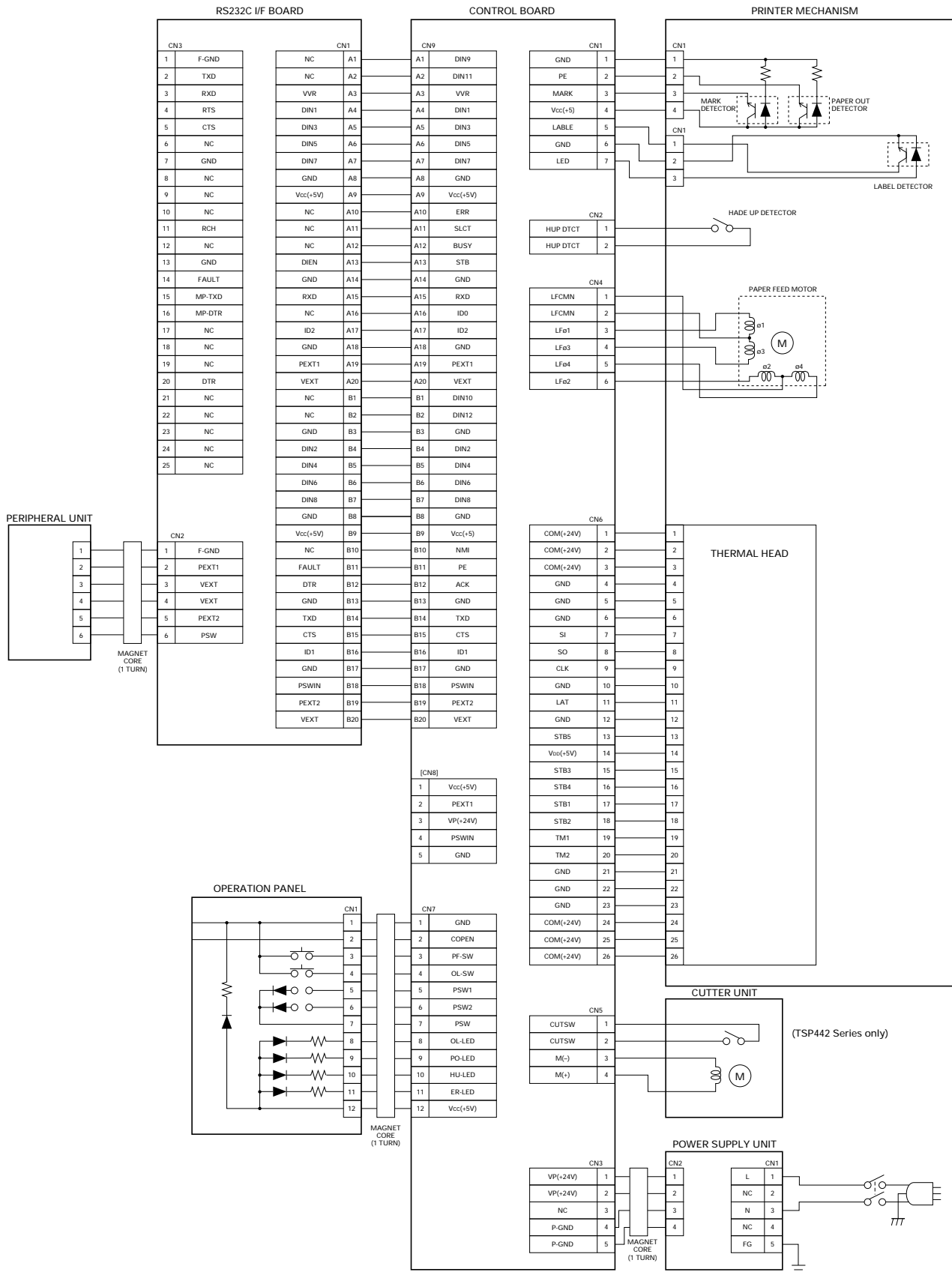

B. RS-422A Interface Type

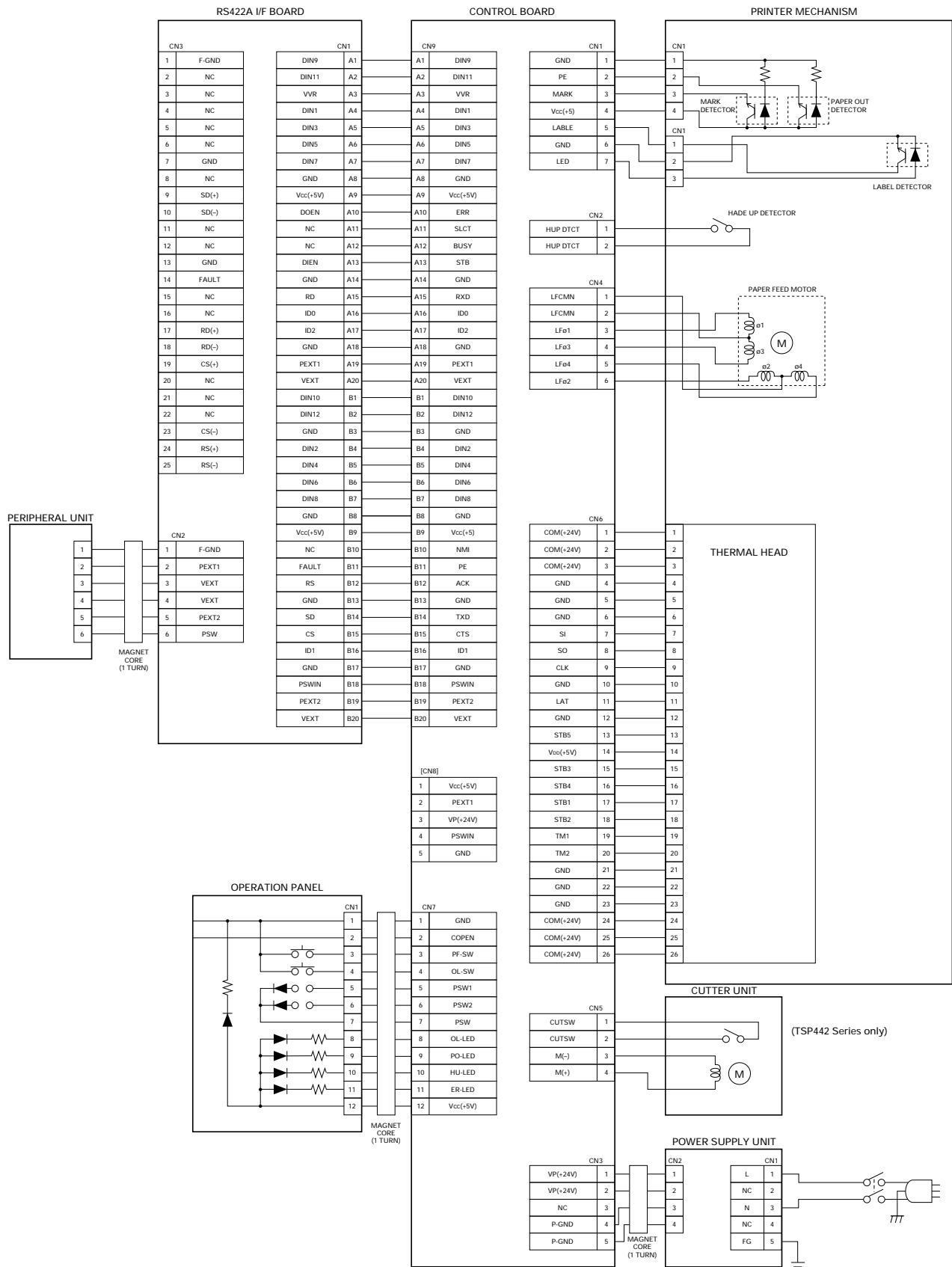

[CN8] is not connected yet.

C. Parallel Interface Type

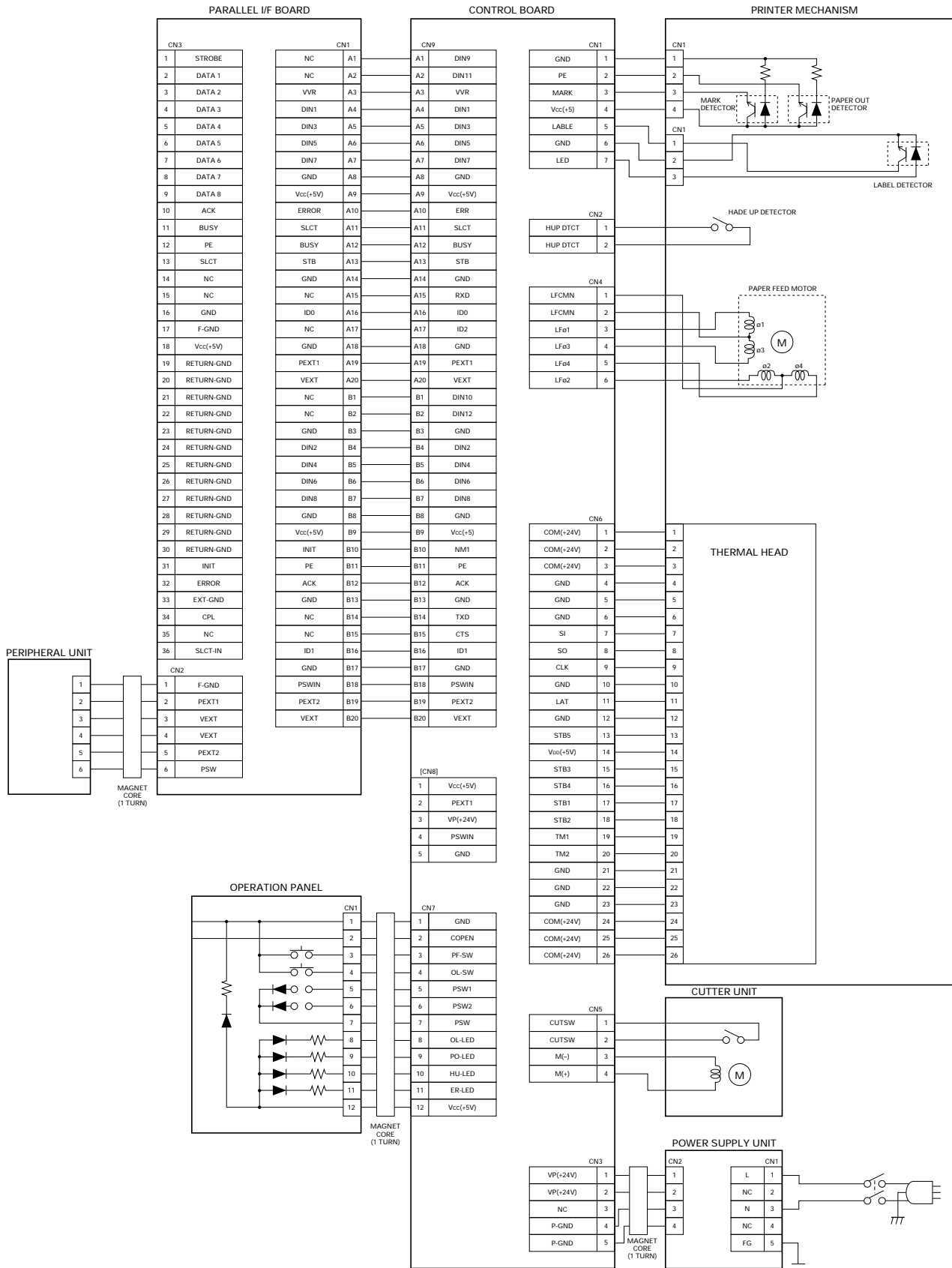

[CN8] is not connected yet.

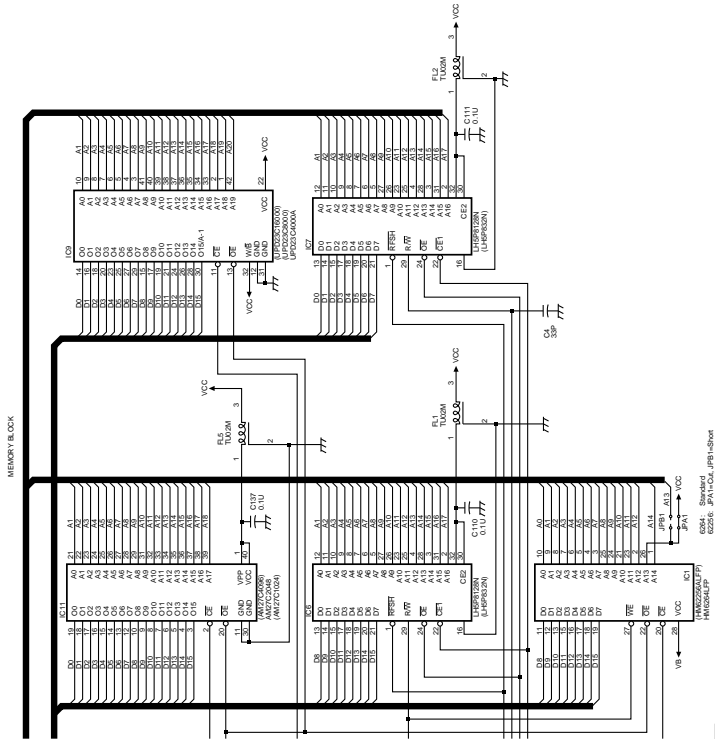
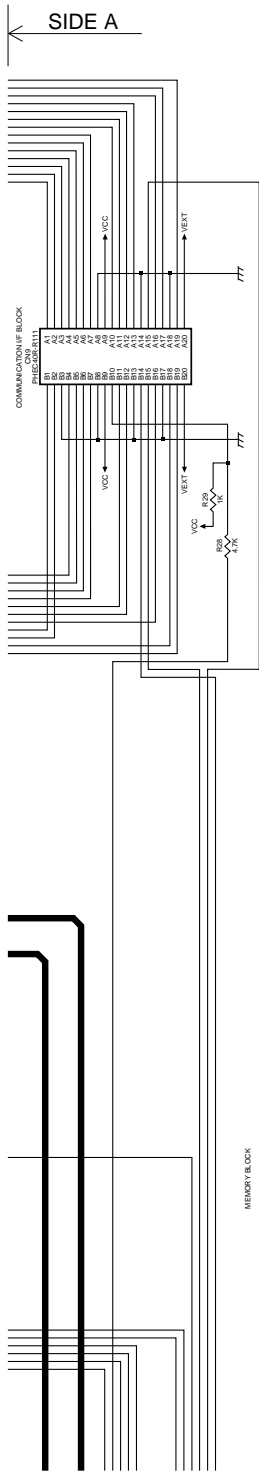

SIDE A

B

D

4-2. Parts List

Main Logic Board

DRWG.NO.	REV.	PARTS NO.	PARTS NAME	Q'TY	REMARKS	RANK
C1		05041081	CHEM. CAPA. 1000UF 35V	1		
C2		05054745	CHEM. CAPA. 0.47UF 50V	1		
C3-5		05753304	CERA. CAPA. CHIP 33PF 50V	3		
C6		05041081	CHEM. CAPA. 1000UF 35V	1		
C7		05994732	BACK-UP CAPA. FYDOH473Z	1		
C8-9		05753304	CERA. CAPA. CHIP 33PF 50V	2		
C10-11		05751045	CERA. CAPA. CHIP 0.1UF 50V	2		
C12		05753304	CERA. CAPA. CHIP 33PF 50V	1		
C13-15		05751045	CERA. CAPA. CHIP 0.1UF 50V	3		
C100-108		05753304	CERA. CAPA. CHIP 33PF 50V	9		
C109-116		05751045	CERA. CAPA. CHIP 0.1UF 50V	8		
C117		05753304	CERA. CAPA. CHIP 33PF 50V	1		
C118		05751045	CERA. CAPA. CHIP 0.1UF 50V	1		
C119		05753304	CERA. CAPA. CHIP 33PF 50V	1		
C120-123		05751015	CERA. CAPA. CHIP 100PF 50V	4		
C124-125		05751045	CERA. CAPA. CHIP 0.1UF 50V	2		
C126		05753304	CERA. CAPA. CHIP 33PF 50V	1		
C127		05751015	CERA. CAPA. CHIP 100PF 50V	1		
C128-131		05753304	CERA. CAPA. CHIP 33PF 50V	4		
C132		05751045	CERA. CAPA. CHIP 0.1UF 50V	1		
C133		05753304	CERA. CAPA. CHIP 33PF 50V	1		
C134-138		05751045	CERA. CAPA. CHIP 0.1UF 50V	5		
CA1-5		05652212	CAPA. ARRAY 220PF 50V 8EL	5		
R1		06753314	CHIP RESISTOR 330 OHM 1/10W	1		
R2-3		06753324	CHIP RESISTOR 3.3 K-OHM 1/10W	2		
R4-5		06753304	CHIP RESISTOR 33 OHM 1/10W	2		
R6		06751031	CHIP RESISTOR 10 K-OHM 1/10W	1		
R7-8		06753304	CHIP RESISTOR 33 OHM 1/10W	2		
R9		06751031	CHIP RESISTOR 10 K-OHM 1/10W	1		
R10		06753304	CHIP RESISTOR 33 OHM 1/10W	1		
R11		06751021	CHIP RESISTOR 1 K-OHM 1/10W	1		
R12-14		06753304	CHIP RESISTOR 33 OHM 1/10W	3		
R15		06751031	CHIP RESISTOR 10 K-OHM 1/10W	1		
R16		06021024	RD RESISTOR 1 K-OHM 1/2W	1		
R17		06751031	CHIP RESISTOR 10 K-OHM 1/10W	1		
R18		06753304	CHIP RESISTOR 33 OHM 1/10W	1		
R19		06751031	CHIP RESISTOR 10 K-OHM 1/10W	1		
R20-23		06753304	CHIP RESISTOR 33 OHM 1/10W	4		
R24		06751021	CHIP RESISTOR 1 K-OHM 1/10W	1		
R25		06751031	CHIP RESISTOR 10 K-OHM 1/10W	1		
R26		06754721	CHIP RESISTOR 4.7 K-OHM 1/10W	1		
R27		06751031	CHIP RESISTOR 10 K-OHM 1/10W	1		
R28		06754721	CHIP RESISTOR 4.7 K-OHM 1/10W	1		
R29		06751021	CHIP RESISTOR 1 K-OHM 1/10W	1		
R30		06754721	CHIP RESISTOR 4.7 K-OHM 1/10W	1		
R31		06752725	CHIP RESISTOR 2.7 K-OHM 1/10W	1		
R32		06754721	CHIP RESISTOR 4.7 K-OHM 1/10W	1		
R33		06752725	CHIP RESISTOR 2.7 K-OHM 1/10W	1		
R100		06751031	CHIP RESISTOR 10 K-OHM 1/10W	1		
R101		06752215	CHIP RESISTOR 220 OHM 1/10W	1		
R102-103		06751031	CHIP RESISTOR 10 K-OHM 1/10W	2		
R104-105		06753324	CHIP RESISTOR 3.3 K-OHM 1/10W	2		
R106		06752031	CHIP RESISTOR 20 K-OHM 1/10W	1		
R107-108		06751031	CHIP RESISTOR 10 K-OHM 1/10W	2		
R109-110		06752031	CHIP RESISTOR 20 K-OHM 1/10W	2		
R111		06751031	CHIP RESISTOR 10 K-OHM 1/10W	1		

Main Logic Board

DRWG.NO.	REV.	PARTS NO.	PARTS NAME	Q'TY	REMARKS	RANK
R112-114		06752031	CHIP RESISTOR 20 K-OHM 1/10W	3		
R115		06751031	CHIP RESISTOR 10 K-OHM 1/10W	1		
R116		06754721	CHIP RESISTOR 4.7 K-OHM 1/10W	1		
R117		06751031	CHIP RESISTOR 10 K-OHM 1/10W	1		
R118		06753304	CHIP RESISTOR 33 OHM 1/10W	1		
R119-120		06751031	CHIP RESISTOR 10 K-OHM 1/10W	2		
R121		06751021	CHIP RESISTOR 1 K-OHM 1/10W	1		
R122		06753324	CHIP RESISTOR 3.3 K-OHM 1/10W	1		
R123		06753304	CHIP RESISTOR 33 OHM 1/10W	1		
R124-126		06751031	CHIP RESISTOR 10 K-OHM 1/10W	3		
R127		06751021	CHIP RESISTOR 1 K-OHM 1/10W	1		
R128		06752031	CHIP RESISTOR 20 K-OHM 1/10W	1		
R129-131		06754721	CHIP RESISTOR 4.7 K-OHM 1/10W	3		
R132-133		06751021	CHIP RESISTOR 1 K-OHM 1/10W	2		
R134		06754721	CHIP RESISTOR 4.7 K-OHM 1/10W	1		
R135		06752215	CHIP RESISTOR 220 OHM 1/10W	1		
R136-137		06751021	CHIP RESISTOR 1 K-OHM 1/10W	2		
RA1		06581039	RESIS. ARRAY 10 K-OHM 1/8W 4EL	1		
VR1		06454732	RP RESISTOR RH0615C-47K	1		
VR2-4		06454721	RP RESISTOR RH0615CS-4.7K	3		
Q1		07320101	TRANSISTOR 2SD2010	1		S
Q2-3		07113591	TRANSISTOR 2SB1359	2		S
Q4		07016491	TRANSISTOR 2SA1649	1		
Q5-6		07013381	CHIP TRANSISTOR 2SA1338-67*TA	2		S
Q7		07238754	CHIP TRANSISTOR 2SC3875S-G*AL	1		S
Q8-9		07320101	TRANSISTOR 2SD2010	2		
DQ1-3		07603016	DIGITAL TRANSISTOR FA1A4P	3		S
DQ4		07603017	DIGITAL TRANSISTOR FN1A4P	1		
DQ5-6		07603016	DIGITAL TRANSISTOR FA1A4P	2		
DQ7-9		07603017	DIGITAL TRANSISTOR FN1A4P	3		
TA1		07650054	TRANSISTOR ARRAY MP4020	1		S
D1		08000048	DIODE EG01YV0	1		
D2-4		08000044	DIODE 1SR139-100AT	3		
DD1-3		08000047	DIODE CHIP DCB010	3		
ZD1		08020090	ZENER DIODE RD7.5EB1T	1		
ZD2		08020095	ZENER DIODE RD4.7JSB1	1		
IC1		08221043	SRAM 6264FP-100NS*EL	1		
IC2		08202020	IC-REG HLD051R2M	1		S
IC3		08202011	IC-REG UPC7824	1		S
IC4		08200109	IC-RESET M51953BL	1		S
IC5		08251006	CPU HD6413003F10T	1		S
IC6-7		08221042	PSRAM 5P8128N-80L*E1	2		
IC8		08222047	EEPROM KM93C46	1		
		09110115	IC SOCKET DILB-8P-8J	1		
IC9		09110076	IC SOCKET DILB-42P-8J	1		
IC10		08240076	GATE ARRAY D65622GF-TSP	1		S
IC11		08222091	EPR0M M5M27C202K-12	1	TS4.**	
		09110020	IC SOCKET DICF-40C-JAE	1		
IC12		08201022	IC-LIN HA17339F*TL	1		
CN1		09100370	CONNECTOR 53014-0710	1		
CN2		09100270	CONNECTOR 5483-02A	1		
CN3		09100614	CONNECTOR 5273-04A	1		
CN4		09100267	CONNECTOR 5483-06A	1		
CN5		09100532	CONNECTOR 5483-04AX-RED	1		
CN6		09100177	CONNECTOR 5332-26SG1	1		
CN7		09100444	CONNECTOR 53014-1210	1		

Main Logic Board

DRWG.NO.	REV.	PARTS NO.	PARTS NAME	Q'TY	REMARKS	RANK
CN8		09100516	CONNECTOR 53014-0510	1		
CN9		09100610	CONNECTOR PHEC40R-R111	1		
X1		09250037	CERA. OSCILLATOR CST9.83MT	1		
FL1-5		09251119	LINE FILTER TU02MT*R	5		
BZ1		45060201	BUZZER QMB-111P	1		

5. RS232C Interface Board

5-1. Circuit Diagram

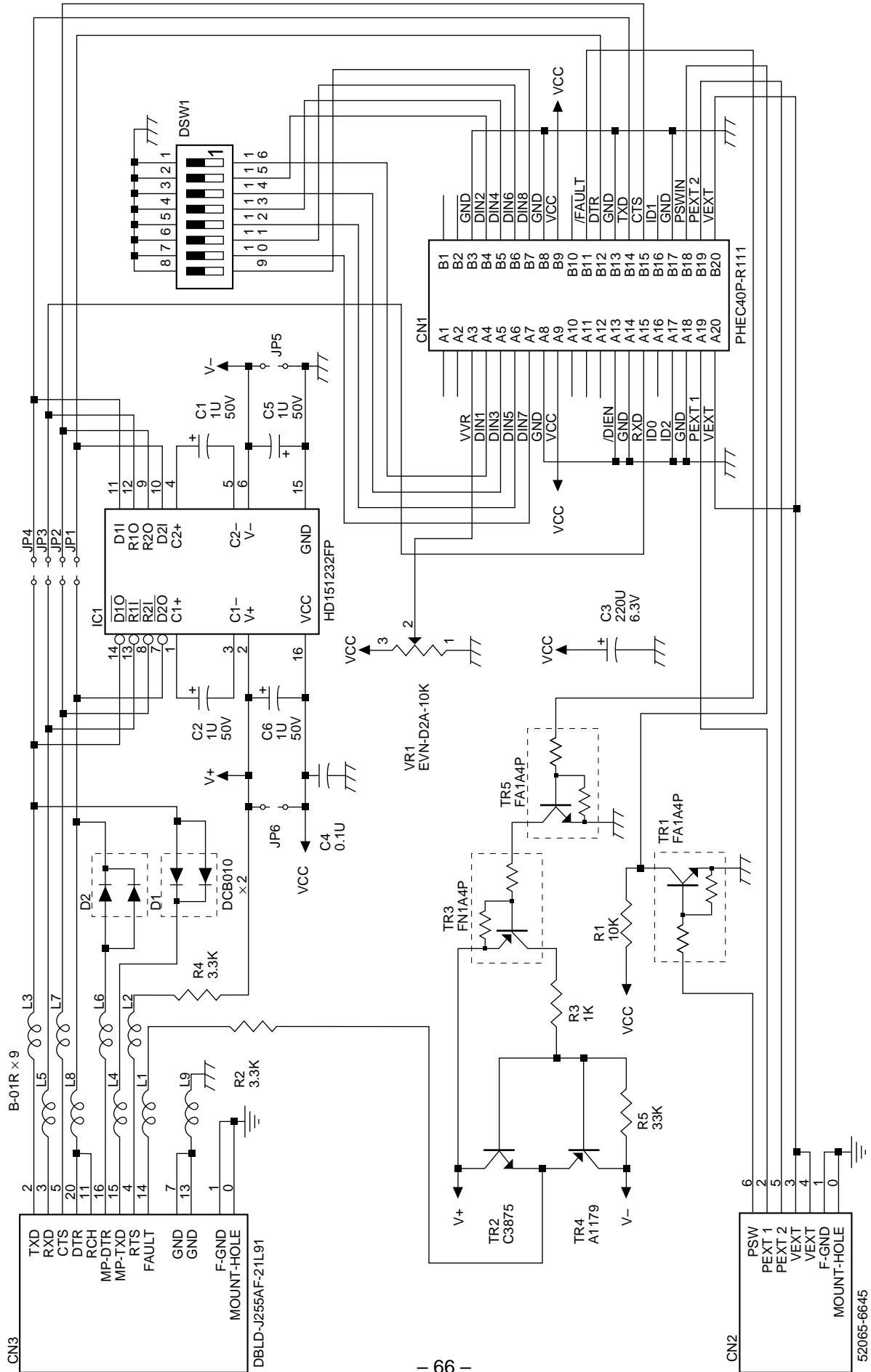

5-2. Parts List

RS232C Interface Board

DRWG.NO.	REV.	PARTS NO.	PARTS NAME	Q'TY	REMARKS	RANK
C1-2		05051057	CHEM. CAPA. 1UF 50V	2		
C3		05002213	CHEM. CAPA. 220UF 6.3V	1		
C4		05751045	CERA. CAPA. CHIP 0.1UF 50V	1		
C5-6		05051057	CHEM. CAPA. 1UF 50V	2		
R1		06751031	CHIP RESISTOR 10 K-OHM 1/10W	1		
R2		06753324	CHIP RESISTOR 3.3 K-OHM 1/10W	1		
R3		06751021	CHIP RESISTOR 1 K-OHM 1/10W	1		
R4		06753324	CHIP RESISTOR 3.3 K-OHM 1/10W	1		
R5		06753334	CHIP RESISTOR 33 K-OHM 1/10W	1		
VR1		06451033	RP RESISTOR EVN-D2A-10K	1		
TR1		07603016	DIGITAL TRANSISTOR FA1A4P	1		
TR2		07238754	CHIP TRANSISTOR 2SC3875S-G*AL	1		
TR3		07603017	DIGITAL TRANSISTOR FN1A4P	1		
TR4		07011793	CHIP TRANSISTOR 2SA1179M6-STR	1		
TR5		07603016	DIGITAL TRANSISTOR FA1A4P	1		
D1-2		08000047	DIODE CHIP DCB010	2		
IC1		08200155	IC-I/F HD151232FP*TL	1		
DSW1	*2	09090034	DIP SWITCH KSS08-1	1		
	#2	09090046	DIP SWITCH EAH108L-BLK	1		
CN1		09100611	CONNECTOR PHEC40P-R111	1		
CN2		09100421	CONNECTOR 52065-6645	1		
CN3		09100483	CONNECTOR DBLD-J25SAF-21L9-1	1		
L1-9		09990705	BEADS INDUCTOR B01-RT	9		

6-2. Parts List

RS422A Interface Board

DRWG.NO.	REV.	PARTS NO.	PARTS NAME	Q'TY	REMARKS	RANK
C1		05751045	CERA. CAPA. CHIP 0.1UF 50V	1		
C2		05002213	CHEM. CAPA. 220UF 6.3V	1		
R1-2		06751014	CHIP RESISTOR 100 OHM 1/10W	2		
R3-4		06751031	CHIP RESISTOR 10 K-OHM 1/10W	2		
VR1		06451033	RP RESISTOR EVN-D2A-10K	1		
TR1		07603016	DIGITAL TRANSISTOR FA1A4P	1		
IC1		08200127	IC-I/F MC34051M	1		
DSW1	*2	09090034	DIP SWITCH KSS08-1	1		
	#2	09090046	DIP SWITCH EAH108L-BLK	1		
DSW2	*2	09090033	DIP SWITCH KSS04-1	1		
	#2	09090045	DIP SWITCH EAH104L-BLK	1		
CN1		09100611	CONNECTOR PHEC40P-R111	1		
CN2		09100421	CONNECTOR 52065-6645	1		
CN3		09100483	CONNECTOR DBLD-J25SAF-21L9-1	1		
L1-10		09990705	BEADS INDUCTOR B01-RT	10		

7. Centronics Interface Board

7-1. Circuit Diagram

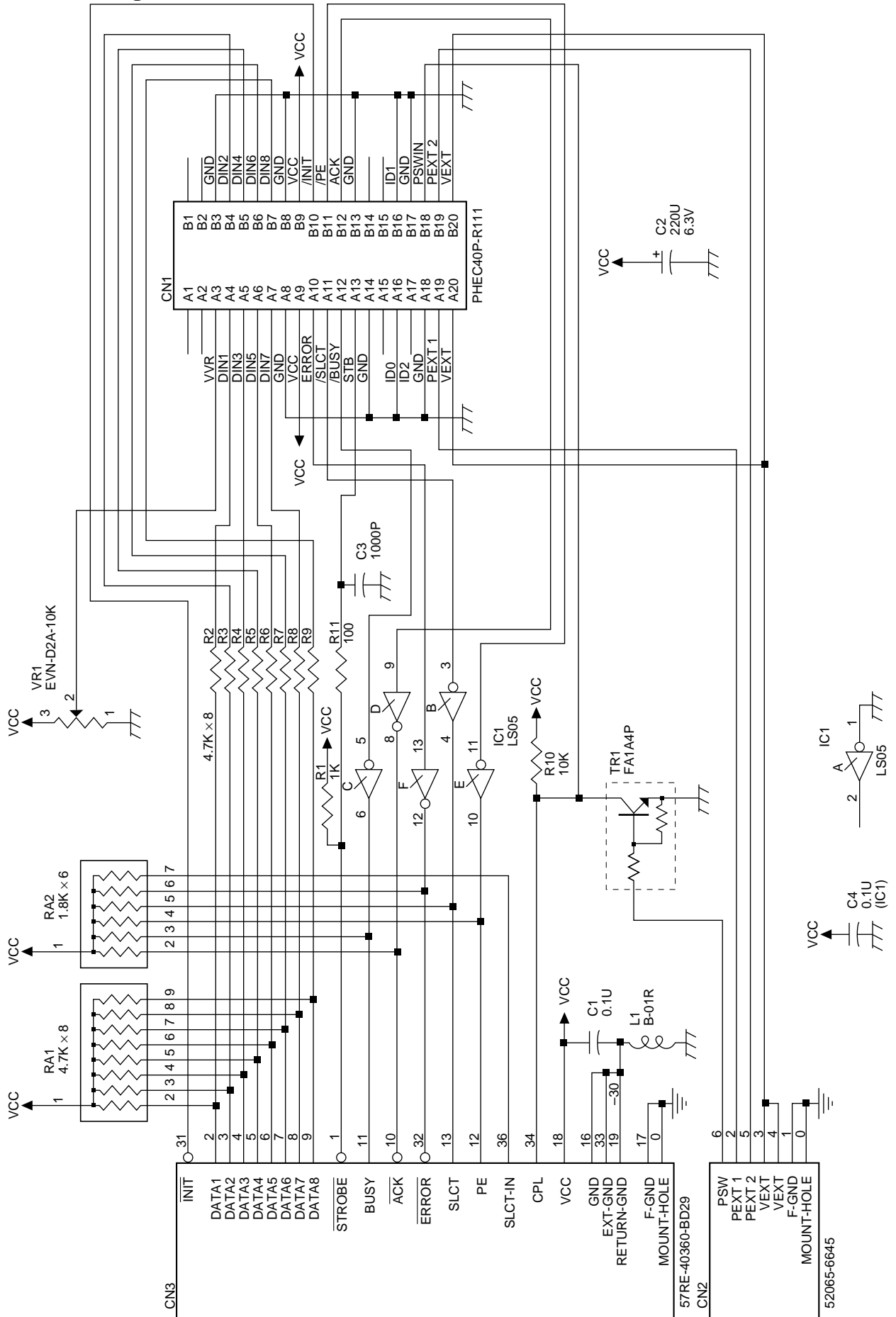

7-2. Parts List

Centronics Interface Board

DRWG.NO.	REV.	PARTS NO.	PARTS NAME	Q'TY	REMARKS	RANK
C1		05751045	CERA. CAPA. CHIP 0.1UF 50V	1		
C2		05002213	CHEM. CAPA. 220UF 6.3V	1		
C3		05751025	CERA. CAPA. CHIP 1000PF 50V	1		
C4		05751045	CERA. CAPA. CHIP 0.1UF 50V	1		
R1		06751021	CHIP RESISTOR 1 K-OHM 1/10W	1		
R2-9		06754721	CHIP RESISTOR 4.7 K-OHM 1/10W	8		
R10		06751031	CHIP RESISTOR 10 K-OHM 1/10W	1		
R11		06751014	CHIP RESISTOR 100 OHM 1/10W	1		
RA1		06584729	RESIS. ARRAY 4.7K-OHM 1/8W 8EL	1		
RA2		06581824	RESIS. ARRAY 1.8K-OHM 1/8W 6EL	1		
VR1		06451033	RP RESISTOR EVN-D2A-10K	1		
TR1		07603016	DIGITAL TRANSISTOR FA1A4P	1		
IC1		08210142	TTL IC 74LS05FP*TL	1		
CN1		09100611	CONNECTOR PHEC40P-R111	1		
CN2		09100421	CONNECTOR 52065-6645	1		
CN3		09100482	CONNECTOR 57RE40360-730BD29	1		
L1		09990705	BEADS INDUCTOR B01-RT	1		

8. Control Panel Board

8-1. Circuit Diagram

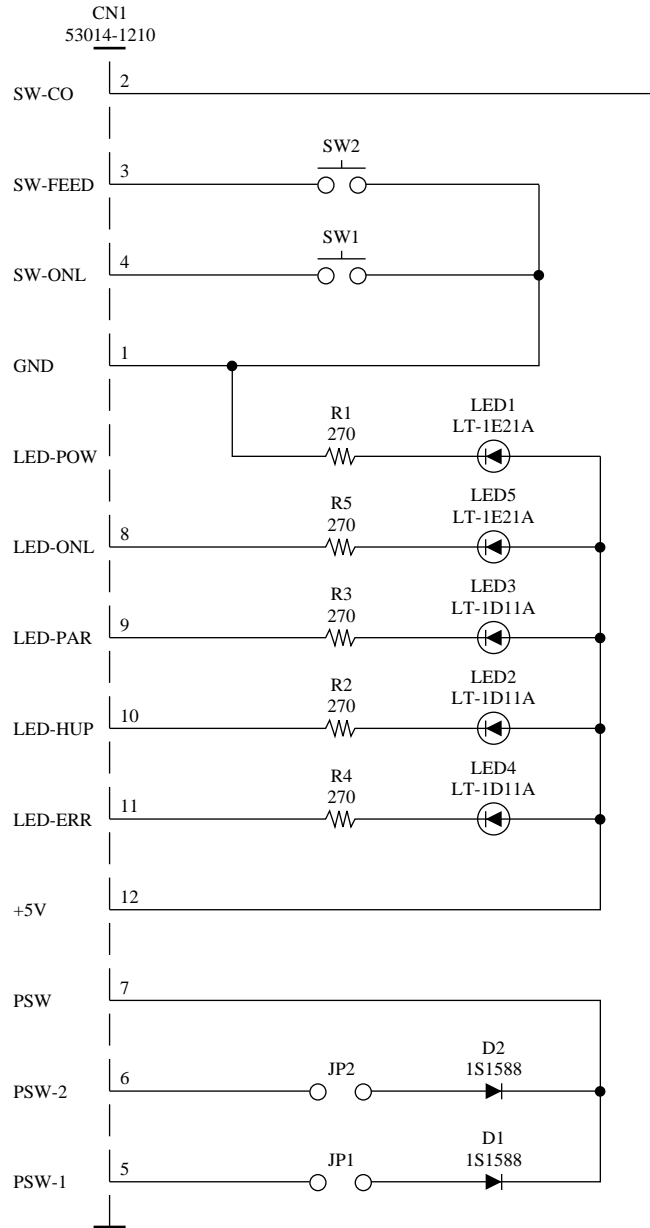

8-2. Parts List

Control Panel Board

DRWG.NO.	REV.	PARTS NO.	PARTS NAME	Q'TY	REMARKS	RANK
R1-5		06052714	RD RESISTOR 270 OHM 1/6W	5		
D1-2		08000039	DIODE 1S1588	2		
LED1		08300058	LED LT-1E21A	1		
LED2-4		08300081	LED LT-1D11A	3		
LED5		08300058	LED LT-1E21A	1		
SW1-2	*1	09010043	PUSH SWITCH SKHHAL=S	2		
	#1	09010041	PUSH SWITCH SKHHAL	2		
CN1		09100444	CONNECTOR 53014-1210	1		
CN2					NOT MOUNTED	
-		09090047	LEAF SWITCH MSW-1705C	1		
		80700580	WIRE 26UL15710RG050	2		

9. Paper-Out Detector Board

9-1. Circuit Diagram

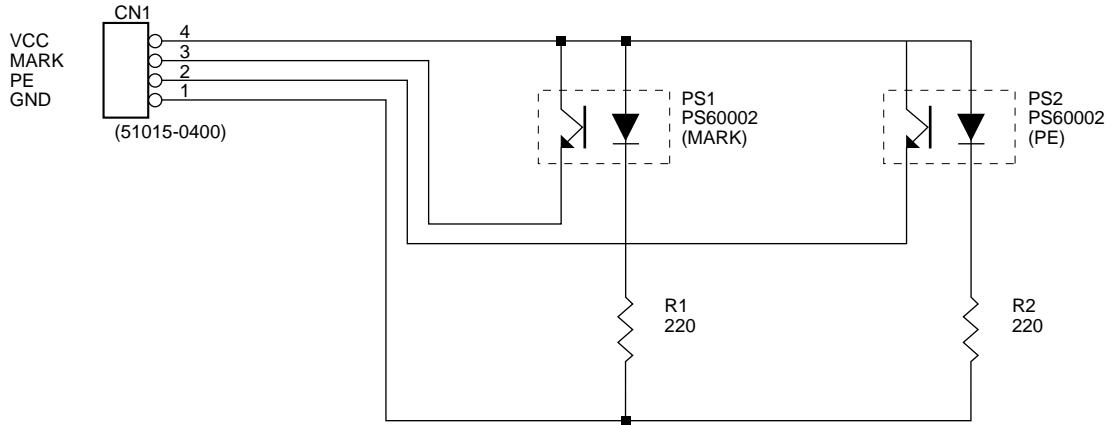

9-2. Parts List

Paper-Out Detector

DRWG.NO.	REV.	PARTS NO.	PARTS NAME	Q'TY	REMARKS	RANK
R1-2		06052211	RD RESISTOR 220 OHM 1/6W	2		
PS1-2		08300082	PHOTO-INTERRUPTER PS6002A-KS	2		
-		30721010	CABLE UNIT	TMP4	1	

10. Label Sensor Board

10-1. Circuit Diagram

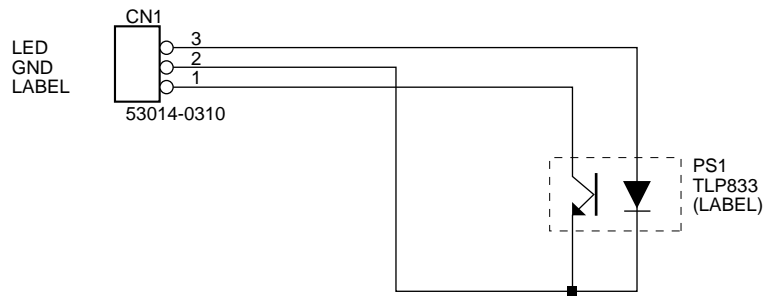

10-2. Parts List

Transmissive Sensor

DRWG.NO.	REV.	PARTS NO.	PARTS NAME	Q'TY	REMARKS	RANK
PS1		08300150	PHOTO-INTERRUPTER TLP833	1		
CN1		09100460	CONNECTOR 53014-0310	1		



**HEAD OFFICE
STAR MICRONICS CO., LTD.**

536 Nanatsushinnya, Shimizu,
Shizuoka, 424, Japan

Tel: 0543-47-0112
Fax: 0543-48-5271

**OVERSEAS SUBSIDIARY COMPANIES
STAR MICRONICS AMERICA, INC.**

70-D Ethel Road West,
Piscataway, NJ 08854, U.S.A.
Tel: (908)572-9512
Telefax: (908)572-5095

STAR MICRONICS DEUTSCHLAND GMBH

Westerbachstraße 59,
D-60489 Frankfurt, Germany
Telefon: 069 78 99 90
Telefax: 069 78 10 06
Telex: 4 175825 star d

STAR MICRONICS U.K. LTD.

Star House, Peregrine Business
Park, Gomm Road, High Wycombe
Bucks, HP13 7DL U.K.
Tel: 01494-471111
Fax: 01494 473333
Telex: 83393 STAR UK

Distributed by