



**38AK,38AKS,38AQS008-012
48/50HJ,48/50TJ,50LJQ008-014
Accessory Low Ambient Operation
Motormaster® III Control Package
50/60 Hz**

Installation Instructions

Part Numbers: CAMOTOR3001A00, CAMOTOR3002A00

CONTENTS

	Page
SAFETY CONSIDERATIONS	1
GENERAL	1,2
INSTALLATION	2-16
Step 1 – Install Motor	2
Step 2 – Install Motormaster III Controller	3
Step 3 – Install Sensor	3
Step 4 – Make Electrical Connections	6
Step 5 – Install Field-Fabricated Wind Baffles and Brackets	6
Step 6 – Restore Power to Unit	6
TROUBLESHOOTING	17

SAFETY CONSIDERATIONS

Installation, start-up, and servicing of this equipment can be hazardous due to system pressures, electrical components, and equipment location (roofs, elevated structures, etc.).

Only trained, qualified installers and service technicians should install, start up, and service this equipment.

When working on this equipment, observe precautions in the literature and on tags, stickers, and labels attached to the equipment and any other safety precautions that may apply.

⚠ WARNING

Open all remote disconnects before servicing this equipment. Electrical shock could result in personal injury.

GENERAL

This book contains instructions for the installation, start-up, and service of the Motormaster III control on 38AKS008-012, 38AQS008, 38AK008-012, 48/50TJ008-014, 48/50HJ008-014, and 50LJQ008,012 units. The Motormaster III control is not used on 50-Hz versions of the 50HJ008-014 and 50LJQ008,012 units.

NOTE: The Motormaster III control is not used on 48/50HJ and 48/50TJ units with 2 condenser fans. The control is used on single condensing fan units only.

The Motormaster III accessory is UL (Underwriters' Laboratories) and CSA (Canadian Standards Association) approved on all split system and small rooftop electric cooling and gas heating/electric cooling units.

The Motormaster III device is a motor speed control device which adjusts condenser fan motor speed in response to declining liquid temperatures. A properly applied Motormaster III control extends the operating range of air conditioning systems and permits operation at lower outdoor ambient temperatures.

Table 1 shows the ambient temperature in cooling at which each unit will operate without modification.

Table 1 – Unit Ambient Temperature Operation

UNIT	COMPRESSOR CAPACITY	CONDENSER TEMP F (C)	MINIMUM OUTDOOR TEMP F (C)
Small Rooftop Units			
All	100%	90 (32)	25 (-4)
Split System Units			
38AQS008 (60 Hz)	100%	90 (32)	55 (13)
38AK/AKS008 (50/60 Hz)	100%	90 (32)	60 (15)
38AKS009 (60 Hz)	100%	90 (32)	53 (12)
38AKS009 (50 Hz)	100%	90 (32)	57 (14)
38AKS012* (50/60 Hz)	100%	90 (32)	48 (9)
	67%	80 (27)	52 (11)
38AK012 (50/60 Hz)	100%	90 (32)	52 (11)

* Unit has one step of unloading.

To operate the units below the ambient temperatures in Table 1, wind baffles and the Motormaster III control package must be added. The Motormaster III control permits operation of the unit to an ambient temperature of -20 F (-29 C) for small rooftop units, and 0 F (-18 C) for split system units.

The Motormaster III regulates the speed of 3-phase fan motors which are compatible with the control. These motors are included in the package. See Tables 2 and 3 for the contents of the Motormaster III accessory packages. The CAMOTOR3001A00 package contains a motor for 208/230 volt, 60 Hz and 220 volt, 50 Hz applications. The CAMOTOR3002A00 package contains a motor for 460 and 575 volt, 60 Hz and 400 volt, 50 Hz applications. See Fig. 1.

Manufacturer reserves the right to discontinue, or change at any time, specifications or designs without notice and without incurring obligations.

**Table 2 – Motormaster® III Control Package
CAMOTOR3001A00, 208/230 v, 60 Hz and 220 v,
50 Hz Applications**

QUANTITY	ITEM	PART NO.
1	Motormaster III Control	HR46GN001
1	Sensor	30GT412176
1	Motor	HD52GK208
8	Screw (5/16-in.)	AL81AS216
1	Relay	HN61KZ024
2	Screw (no. 6 – 20 x 3/4-in)	AL56AU128
1	Bracket	50DK507132
1	Socket	HY07RB030

**Table 3 – Motormaster III Control Package
CAMOTOR3002A00, 460 and 575 v, 60 Hz and
400 v, 50 Hz Applications**

QUANTITY	ITEM	PART NO.
1	Motormaster III Control	HR46GN001
1	Sensor	30GT412176
1	Motor	HD52GK460
8	Screw (5/16-in)	AL81AS216
1	Relay	HN61KZ024
2	Screw (no. 6 – 20 x 3/4-in.)	AL56AU128
1	Bracket	50DK507132
1	Socket	HY07RB030

Before Installing — Inspect the contents of the accessory package before installing. File a claim with the shipper if shipping damage is found. Contact the Carrier distributor if a part is missing.

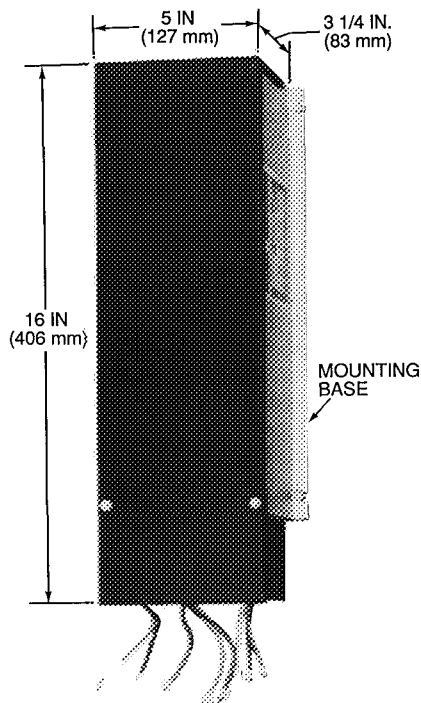

Fig. 1 – Motormaster III Control

INSTALLATION

Step 1 – Install Motor

⚠ WARNING

To avoid the possibility of electrical shock, open all disconnects before installing or servicing this accessory.

1. Shut off unit power supply.
 2. Remove unit access panel and control box cover.
 3. Disconnect fan motor connection in control box and remove motor leads from control box.
 4. Remove condenser fan assembly (grille, motor, motor cover, and fan) by removing the 6 grille holddown screws.
 5. Loosen fan hub set screws and remove condenser fan from motor shaft.
 6. Carefully lift off motor cover.
 7. Remove the 4 holddown nuts that attach the motor to the grille. Pull the motor wires through the grille conduit.
 8. Cut back the steel conduit on the grille (one grille wire width) to allow adequate space for new fan motor.
 9. Feed the Motormaster III motor wires through the conduit and install motor from accessory kit onto grille using nuts from Step 7.
 10. Replace the motor cover on the grille using the square cutouts.
 11. Replace condenser fan on motor shaft.
 12. Adjust fan height as shown in Fig. 2.
 13. Tighten set screws on fan hub to 7 ft-lbs (9.52 N-m [newton-meters]) \pm 1 ft-lb (1.5 N-m).
- NOTE: On 48HJ009 and 48HJ/TJ014 units, perform Step 2 – Install the Motormaster III Controller through Step 4 – Make Electrical Connections, before reinstalling the condenser fan. Motormaster III installation is done through the condenser fan opening with the fan and motor removed.
14. Reinstall condenser fan assembly onto unit using screws from Step 4. Torque to 20 in.-lbs (2260 mN-m) \pm 2 in.-lbs (226 mN-m).
 15. Pull motor wires completely through conduit.

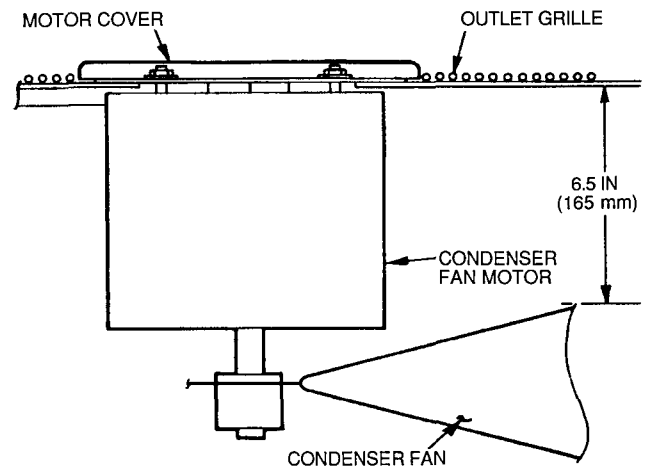

Fig. 2 – Condenser Fan Height Adjustment

Step 2 – Install Motormaster® III Controller

1. Configure the control signal selection switch. Remove the cover of the Motormaster III control. Set the switch on the Motormaster III control board (underneath cover) to accept the thermistor (sensor) input signal. Set the frequency switch to match the unit power supply (50 Hz or 60 Hz). See Fig. 3 for switch locations and proper position. Replace the cover.
2. 38AK008,012; 38AKS008-012; 48HJ008,012; 48TJ008-012; 50HJ/TJ008-014; AND 50LJQ008,012; UNITS WITH SINGLE POINT BOX: Mount the Motormaster III controller on the unit in the location specified in Fig. 4-6. The controller must be mounted vertically with the leads at the bottom. Using the template provided on the last page of the book, mark the 4 mounting hole locations. Mount the controller using the 5/16-in. self-drilling screws provided.

⚠ CAUTION

To avoid damaging components and wiring, use extreme care when drilling screw holes and screwing in fasteners.

50HJ/TJ008-014 AND 50LJQ008,012 UNITS WITHOUT SINGLE POINT BOX; 48HJ009 (208/230 AND 460 V); AND 48HJ/TJ014 UNITS: Mount the Motormaster III controller on the unit in the location specified in Fig. 7 and 8. The controller must be mounted vertically with the leads at the bottom. Using the template supplied on the last page of the manual, mark the 4 mounting locations. Mount the controller using the 5/16-in. self-drilling screws provided. To prevent any water leakage through the bulkhead (the partition separating the indoor and outdoor sections), an electric

component compatible, general purpose silicon rubber sealant must be used along the 4 edges of the controller and at the 4 mounting-screw locations.

38AQS008 AND 48HJ009 (575 V) UNITS: The Motormaster III controller must be mounted on a sheet metal bracket provided. Mount the bracket on the unit in the location specified in Fig. 9 and 10 using four 5/16-in. self-drilling screws provided. If needed, a bracket mounting template is provided on page 21. The controller must be mounted vertically, with the leads at the bottom. Mount the controller on the bracket using the remaining four 5/16-in. self-drilling screws. See Fig. 11 for controller mounting details.

Step 3 – Install Sensor

38AK008,012; 38AKS008-012 AND 48/50HJ, TJ008-014 UNITS — Install the sensor for thermistor input control on the header tube designated in Fig. 12. Connect the sensor leads to the violet and gray control signal leads on the Motormaster III controller. Wrap and tie excess sensor wiring. Refer to Step 4 – Make Electrical Connections and the unit wiring diagram for more information on wiring the sensor.

⚠ CAUTION

Sensor assembly is delicate. Handle with care.

38AQS008 AND 50LJQ008,012 UNITS — Wiring is field-supplied. Wiring must be 16 AWG (American Wire Gauge) (1.5 mm²), appliance wiring material, rated 75 C or its equivalent, with 2/64-in. (.8 mm) minimum insulation thickness. All wiring must comply with NEC (National Electrical Code) and applicable local codes.

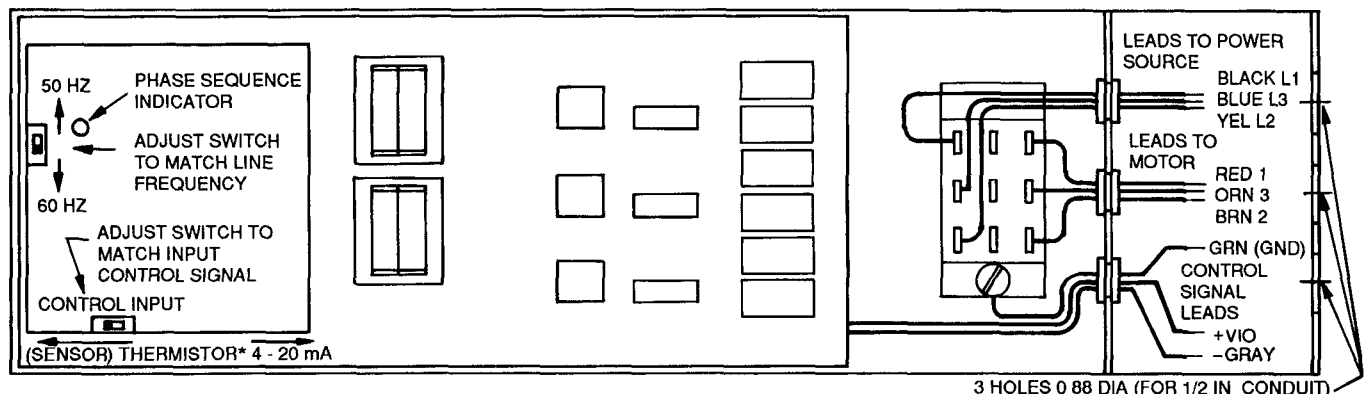

LEGEND

GND — Ground

*For thermistor (sensor) signal, move switch to the left.

NOTE: Thermistor is designated in text as "sensor."

Fig. 3 – Motormaster III Control Signal Selection Switch

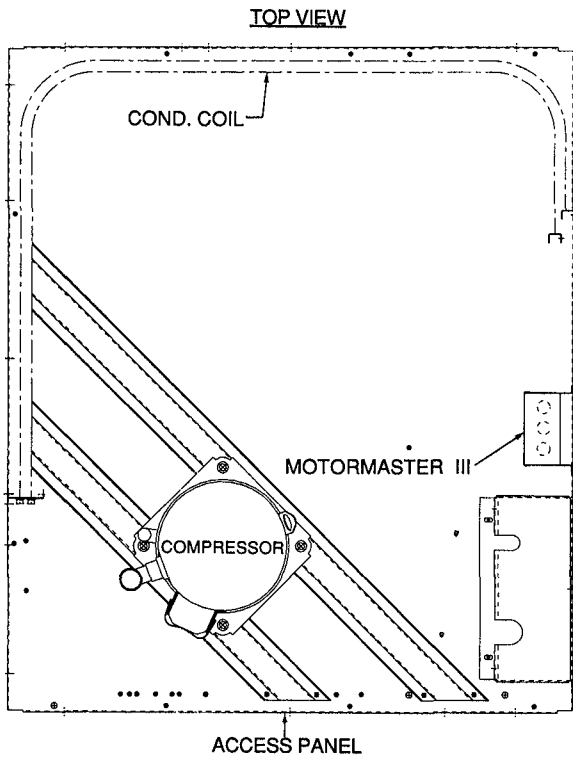

Fig. 4 - Motormaster® III Controller Location - 38AK, 38AKS Units

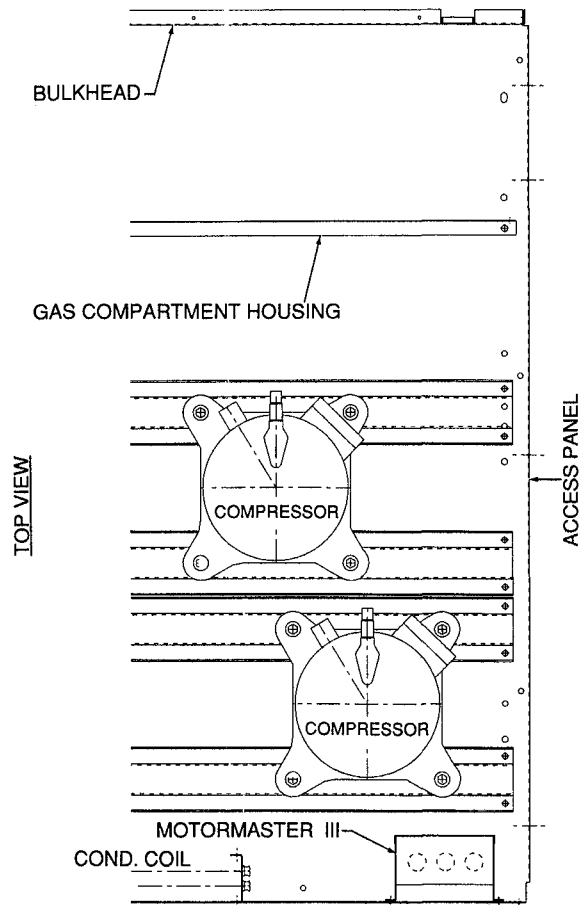

Fig. 6 - Motormaster III Controller Location - 48HJ/TJ008, 48TJ009, 48HJ/TJ012

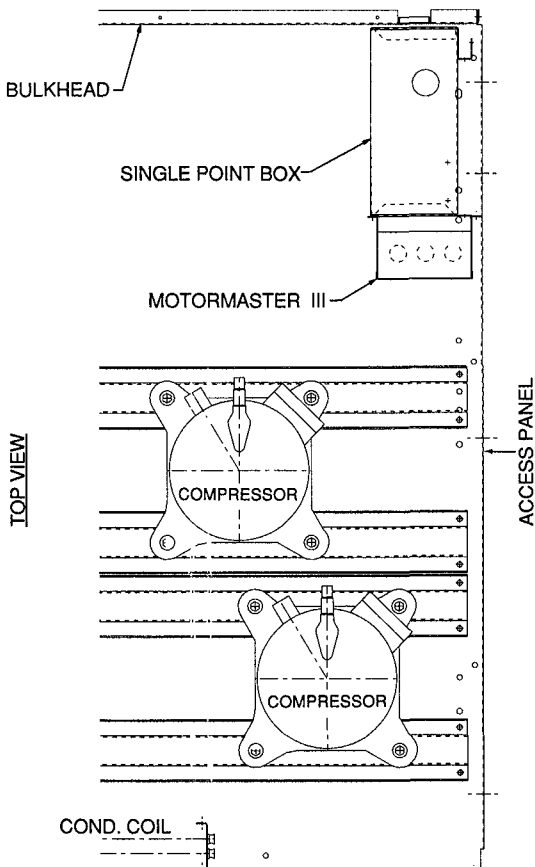

Fig. 5 - Motormaster III Controller Location - 50HJ, 50LJQ, 50TJ008-014 (With Single Point Box)

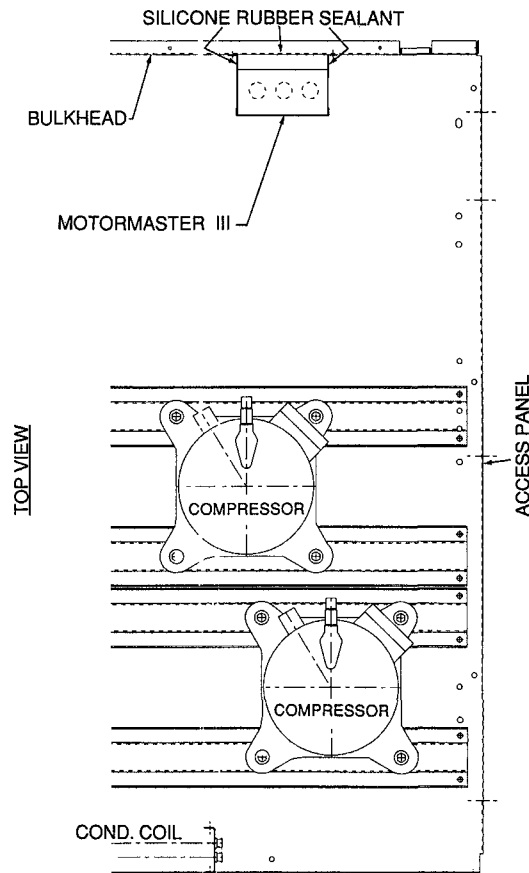

Fig. 7 - Motormaster III Controller Location - 50HJ, 50LJQ, 50TJ008-014 (Without Single Point Box)

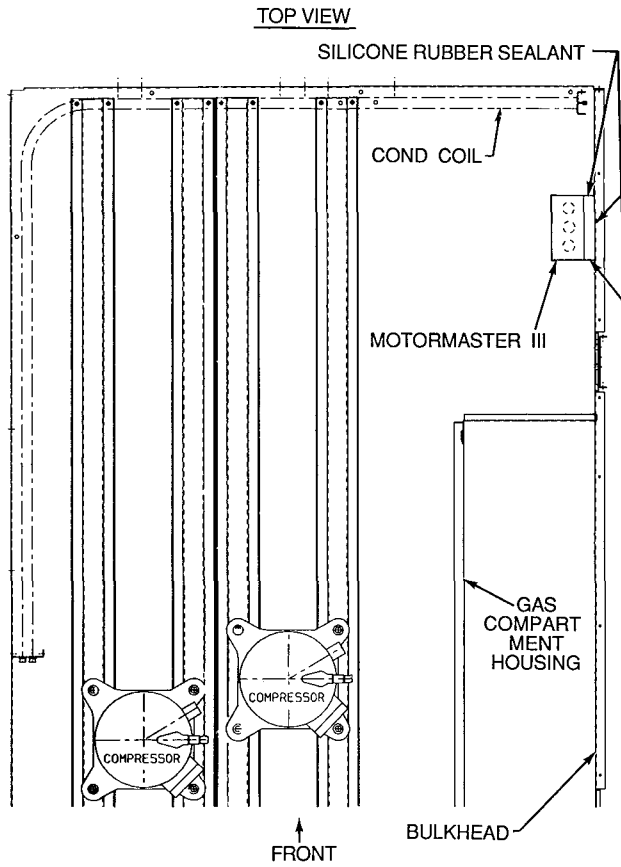

Fig. 8 – Motormaster® III Controller Location – 48HJ,TJ014, All Voltages; 48HJ009, 208/230, 460-3-60 Only

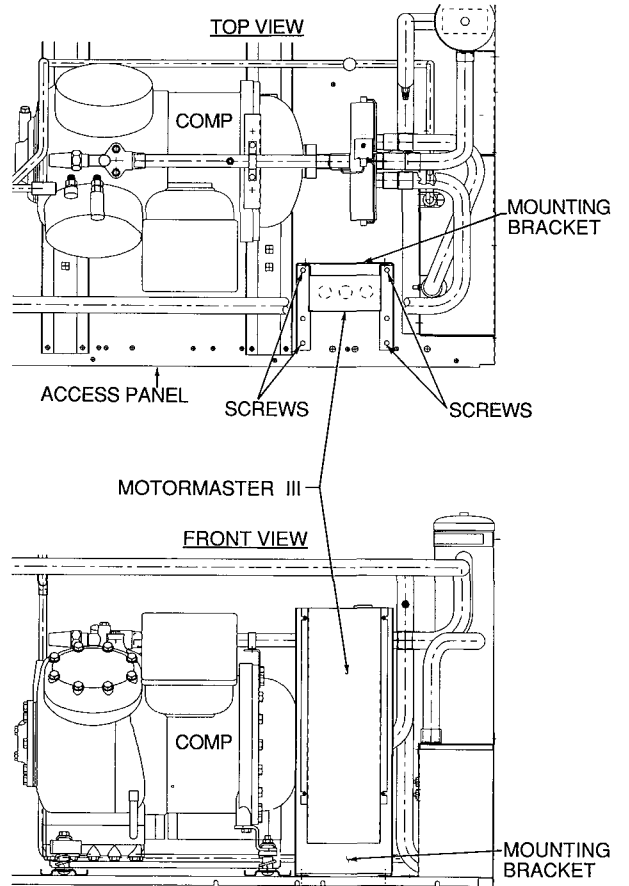

Fig. 10 – Motormaster III Controller Location – 38AQS008

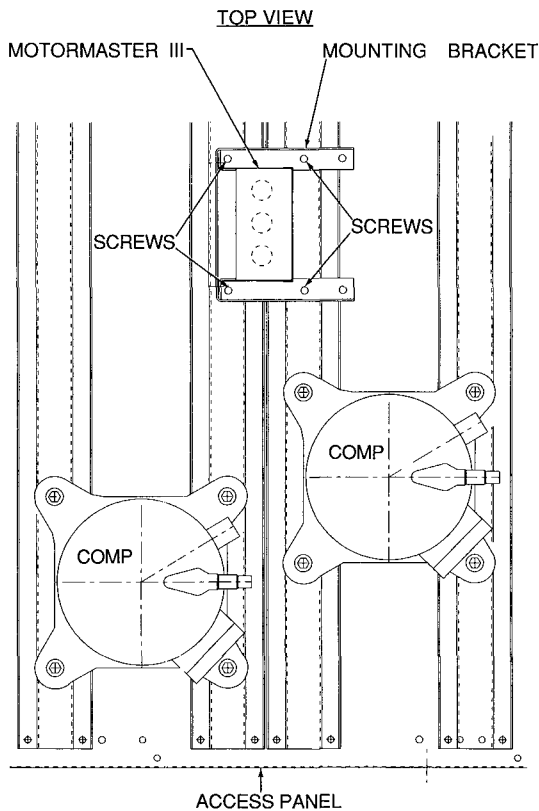

Fig. 9 – Motormaster III Controller Location – 48HJ009 (575 V)

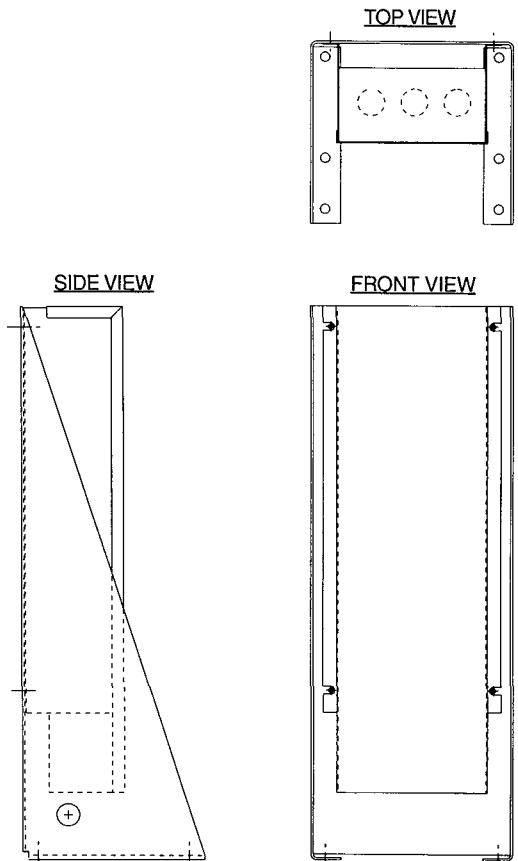

Fig. 11 – Motormaster III Controller Mounting

Install the sensor for thermistor input control on the header tube designated in Fig. 13 and 14. Insert relay into socket. Install the Motormaster® III relay in the unit control box, in the location specified in Fig. 15 and 16. Use the two no. 6-20 x 3/4-in. screws provided.

Connect one sensor lead to the violet control signal lead on the Motormaster III controller and to a field-supplied 16 AWG wire with a wirenut. Connect the remaining sensor lead to the gray control sensor lead on the Motormaster III controller and to another field-supplied 16 AWG wire with a wirenut.

Route both field-supplied wires through a factory-punched access hole under the control box. Attach the wires to screw terminals 1 and 9 on the Motormaster III relay in the control box. Wrap and tie excess sensor wiring. Wrap wirenuts with waterproof tape to prevent them from loosening and to ensure watertightness. Refer to Step 4 – Make Electrical Connections and the unit wiring diagram for more information on wiring the sensor.

⚠ CAUTION

Sensor assembly is delicate. Handle with care.

Step 4 – Make Electrical Connections

⚠ WARNING

To avoid possibility of electrical shock and personal injury, turn off all power to unit before making electrical connections. Tag all disconnects to alert others not to turn on power until work is completed.

The wires necessary for wiring the Motormaster III control to the unit must be field-supplied. Use 16 AWG (American Wire Gauge) (1.5 mm²) appliance material wire, with 2/64-in. (.8 mm) minimum insulation thickness. Use 75 C type or equivalent. All wiring must comply with NEC (National Electrical Code) and applicable local codes.

38AK008,012 AND 38AKS008-012 UNITS — Power wiring must comply with all local and national electrical code (NEC) requirements. Refer to Fig. 17-19 for power wiring connections. Utilize field-supplied wirenuts and ¼ in. insulated female quick-connects for making power wiring connections. Wrap wirenuts with waterproof tape to prevent them from loosening and ensure watertightness.

NOTES:

1. On 50 Hz units, disconnect the yellow wire connected to terminal 22 of the compressor contactor (C).
2. See wiring diagram on unit for more details.

48/50HJ008-014 AND 48/50TJ008-014 UNITS — Power wiring must comply with all local and National Electrical Code (NEC) requirements. Refer to Fig. 20-25 for power wiring connections. Utilize field-supplied wirenuts and ¼-in. insulated female quick-connects for making power wiring connections. Wrap wirenuts with waterproof tape to prevent them from loosening and ensure watertightness.

NOTES:

1. On 220 v, 50 Hz units, disconnect the black wire connected to capacitor 1. On 400 v, 50 Hz units, disconnect blue wire connected to capacitor 1. Cap wire with a wirenut (50TJ008-014 only).
2. See wiring diagram on unit for more details.

38AQS008 AND 50LJQ008,012 UNITS — Power wiring must comply with all local and National Electrical Code (NEC) requirements. Refer to Fig. 26-28 for power wiring connections. Utilize field-supplied wirenuts and ¼-in. insulated female quick-connects for making power wiring connections. Wrap wirenuts with waterproof tape to prevent them from loosening and ensure watertightness. See wiring diagram on unit for more details.

Step 5 – Install Field-Fabricated Wind Baffles and Brackets

⚠ WARNING

To avoid the possibility of electrical shock, open all disconnects before installing or servicing this accessory.

Wind baffles must be field-fabricated for all units to ensure proper cooling cycle operation at low-ambient temperatures with Motormaster III controls. See Fig. 29 and 30 for number and sizes of baffles required and for baffle details. Use 20-gage (1 mm) galvanized sheet metal or similar corrosion-resistant material for the baffles. Use field-supplied screws to attach baffles to unit. Screws should be ¼-in. (6.3 mm) diameter or larger. Drill required screw holes for mounting the baffles.

⚠ CAUTION

To avoid damage to refrigerant coils and electrical components, use extreme care when drilling screw holes and screwing in fasteners.

Step 6 – Restore Power To Unit – When all electrical connections have been made, ensure they are tight and correct.

1. Restore power to the unit.
2. Check the phase sequence indicator on the Motormaster III control. It should not be lit. If lit, turn off power and reverse L1 (black) and L2 (yellow) power leads. See Fig. 3.
3. With phasing on Motormaster III control correct, make sure that the fan motors are rotating in the proper direction. If fan rotation is backwards, shut off power. Reverse the supply power leads between the Motormaster III control and the condenser fan motor to correct rotation.
4. Reinstall control box cover.
5. Reinstall unit access panel.

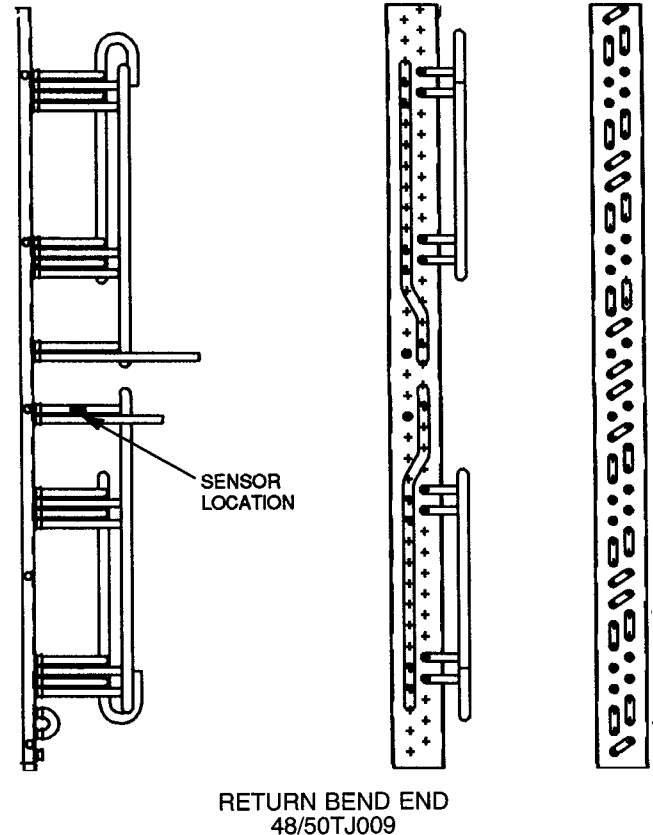
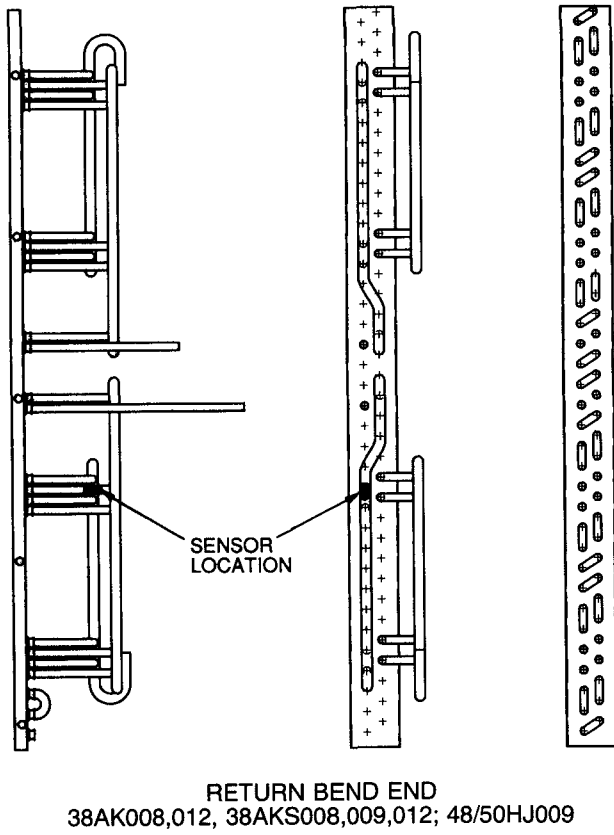
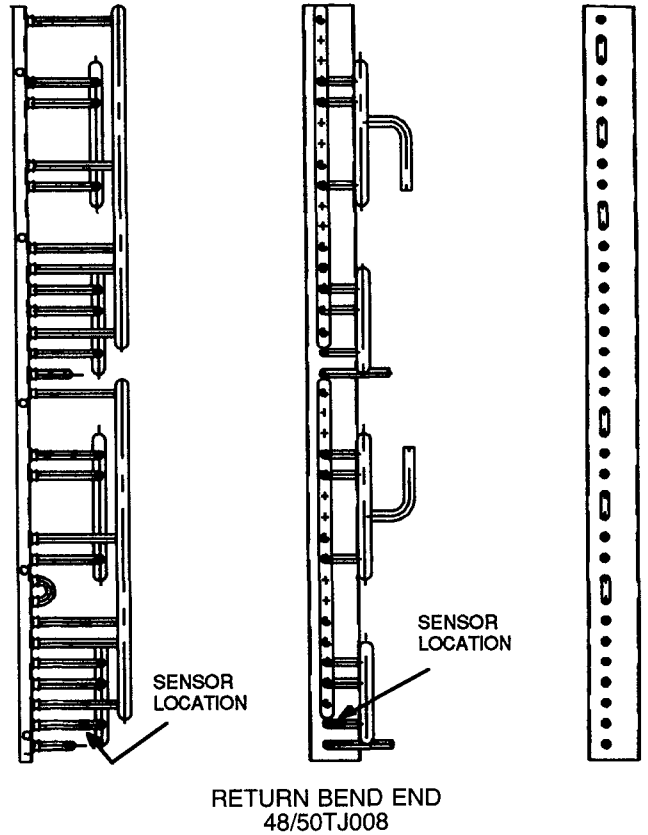
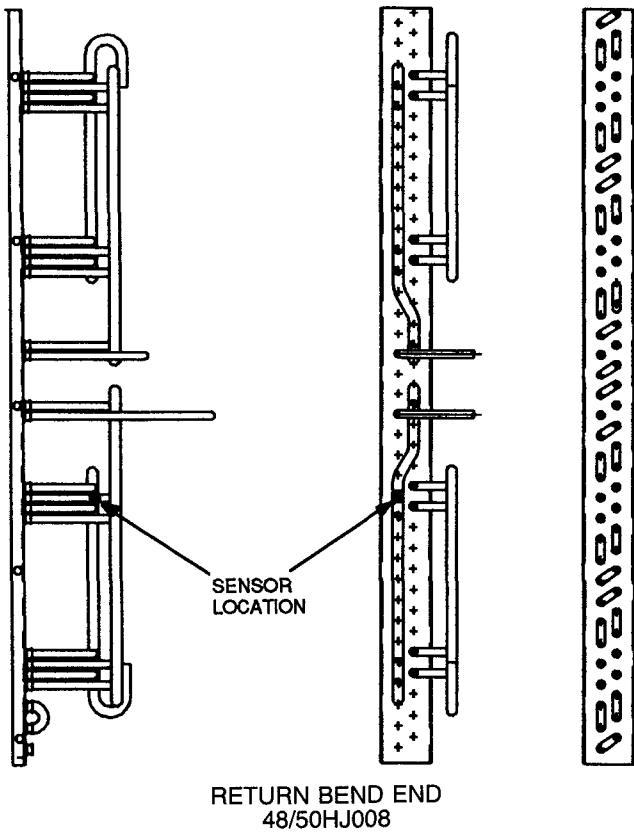
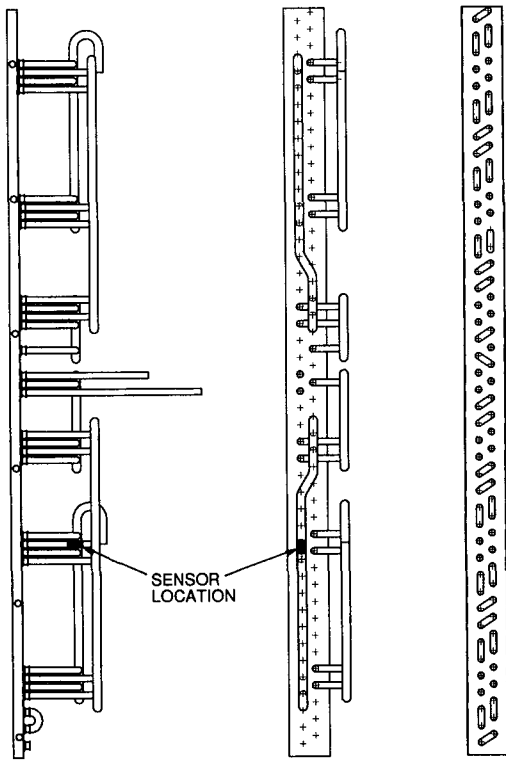
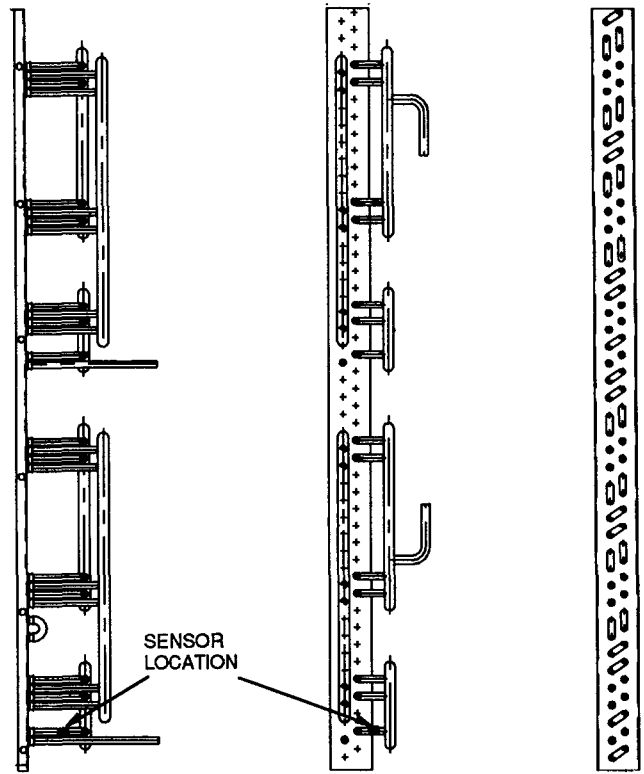

Fig. 12 – Motormaster® III Sensor Locations – 38AK, AKS; 48/50HJ,TJ Units



RETURN BEND END
48/50HJ012



RETURN BEND END
48/50TJ012

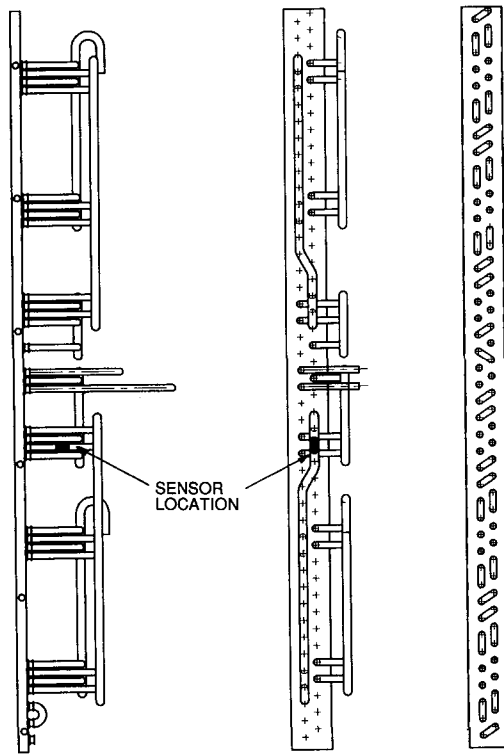

RETURN BEND END
48/50HJ,TJ014

Fig. 12 – Motormaster® III Sensor Locations – 38AK, AKS and 48/50HJ,TJ UNITS (cont)

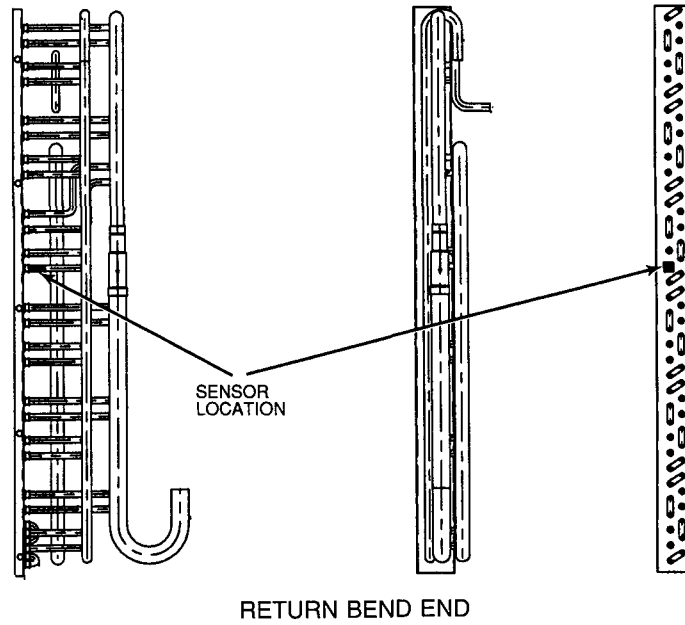

Fig. 13 – Motormaster® III Sensor Locations – 38AQS Units

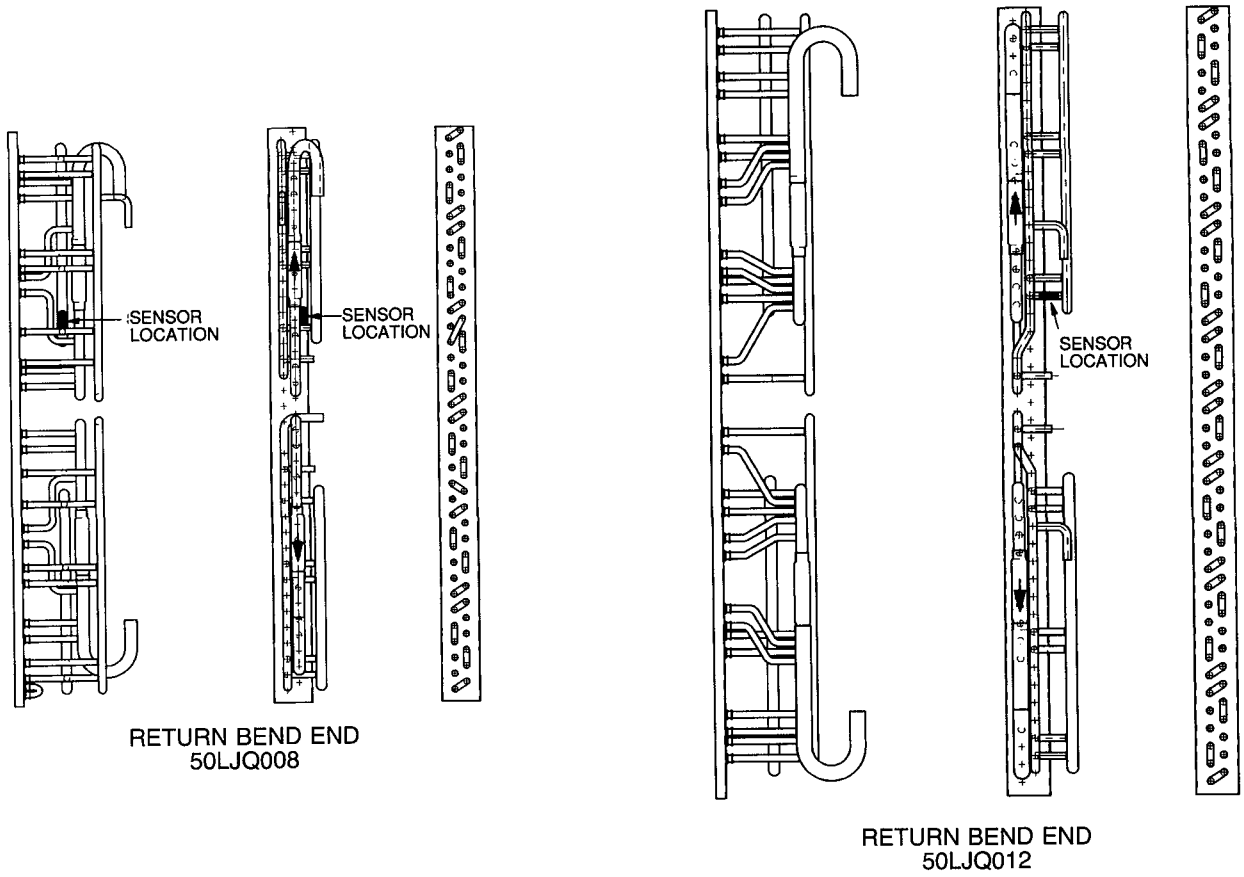
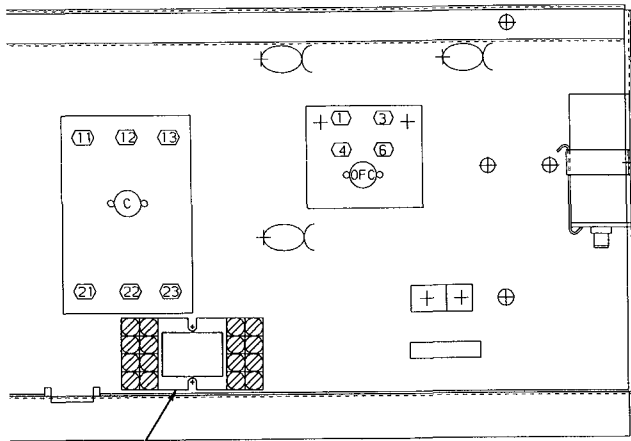
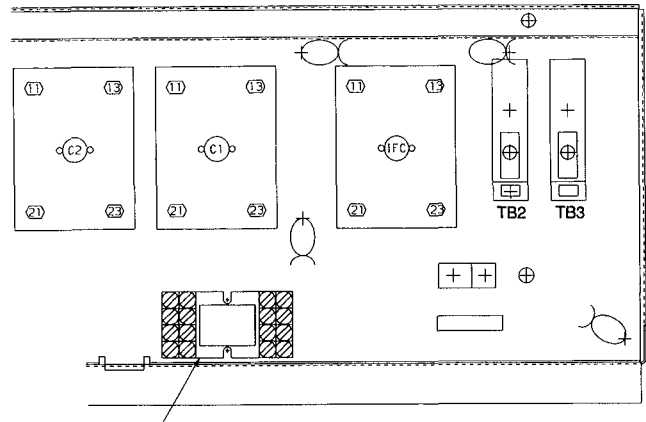

Fig. 14 – Motormaster III Sensor Locations – 50LJQ Units



MOTORMASTER III RELAY

Fig. 15 - Motormaster® III Relay Location - 38AQS008



MOTORMASTER III RELAY

Fig. 16 - Motormaster III Relay Location - 50LJQ008,012

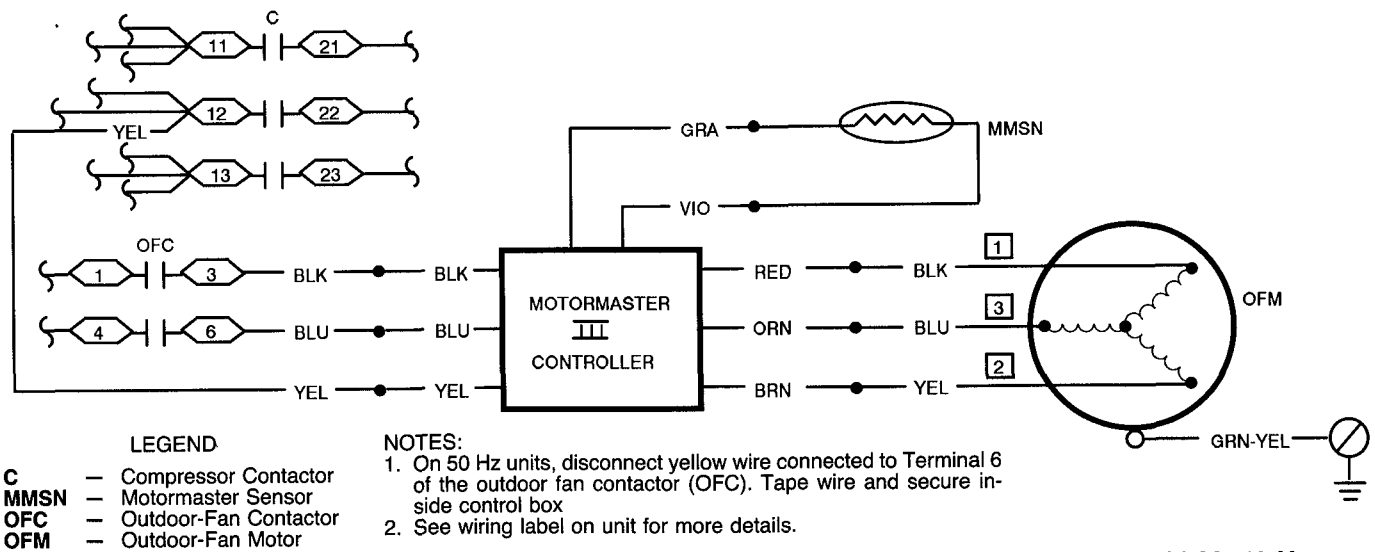

Fig. 17 - Fan Power Wiring - 38AKS009,012 - 208/230 V, 460 V; 60 Hz and 220 V, 400 V; 50 Hz

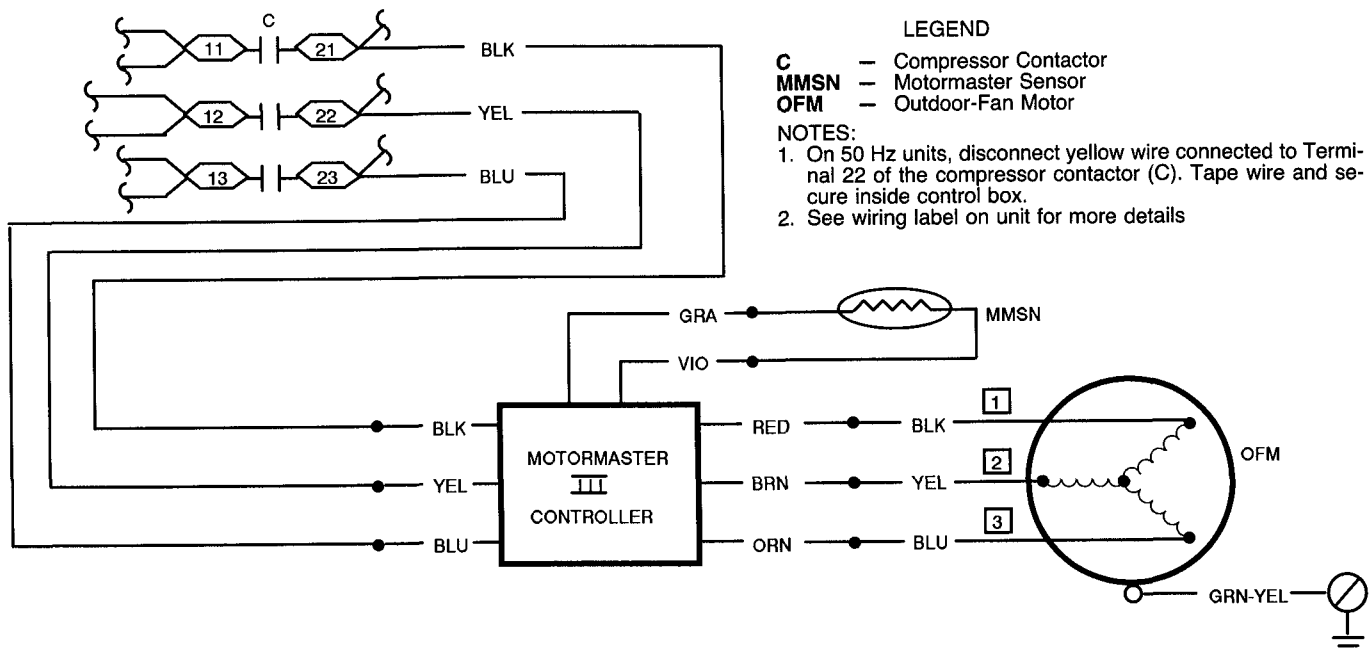

Fig. 18 - Fan Power Wiring - 38AK008,012; 38AKS008 - 208/230 V, 460 V; 60 Hz and 220 V, 400 V; 50 Hz

LEGEND

- MMSN** - Motormaster® Sensor
 - OFC** - Outdoor-Fan Contactor
 - OFM** - Outdoor-Fan Motor
 - TB2** - Terminal Block 2
- NOTE: See wiring label on unit for more details

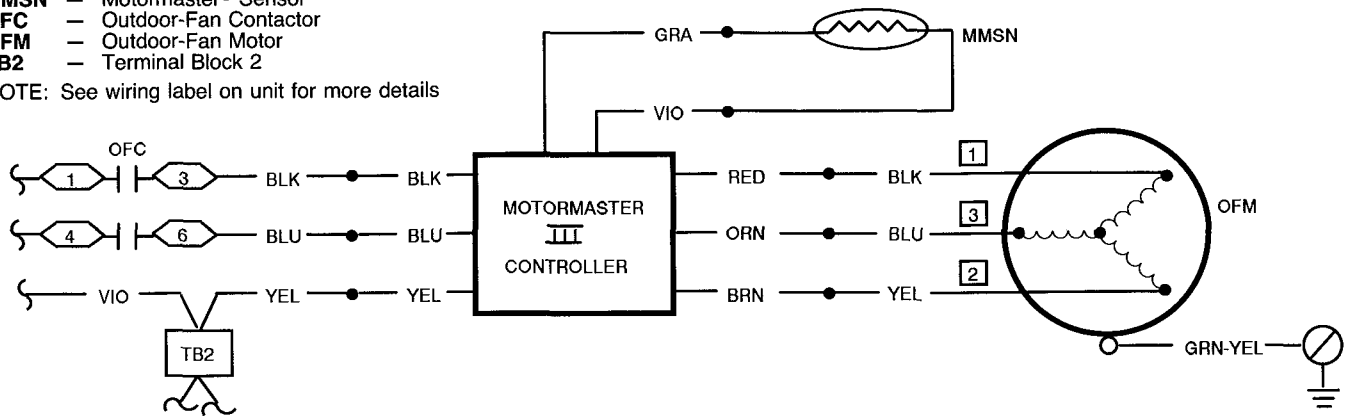
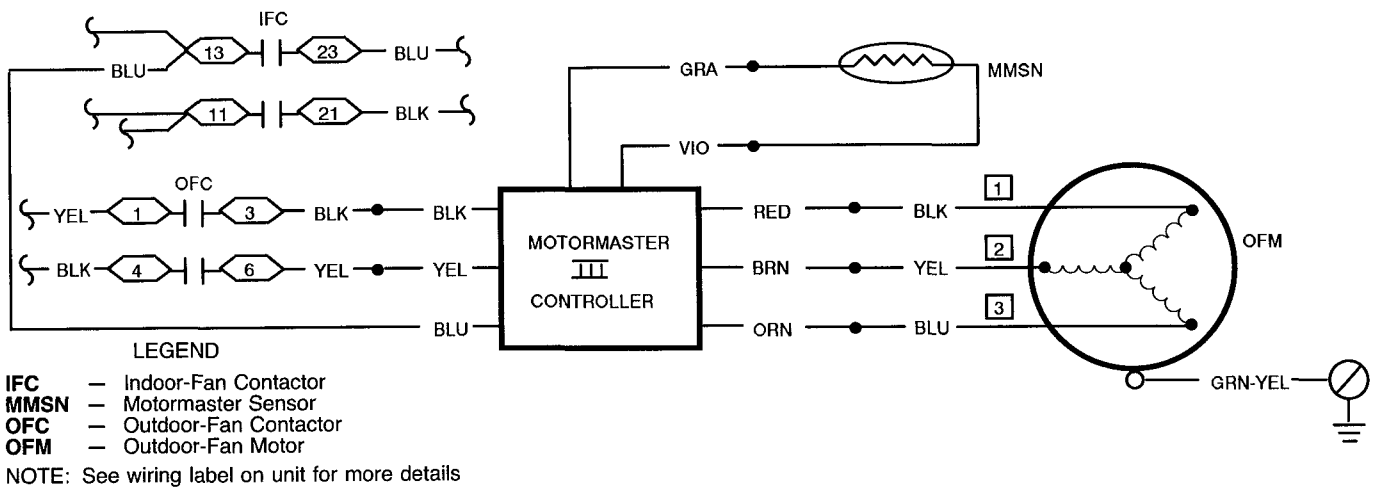

Fig. 19 - Fan Power Wiring - 38AK008,012; 38AKS008,009,012 - 575 V; 60 Hz



LEGEND

- IFC** - Indoor-Fan Contactor
 - MMSN** - Motormaster Sensor
 - OFC** - Outdoor-Fan Contactor
 - OFM** - Outdoor-Fan Motor
- NOTE: See wiring label on unit for more details

Fig. 20 - Fan Power Wiring - 50HJ008-012 - 208/230 V; 60 Hz, 50HJ008-014 - 460 V; 60 Hz, and 50TJ014 - 460 V; 60 Hz

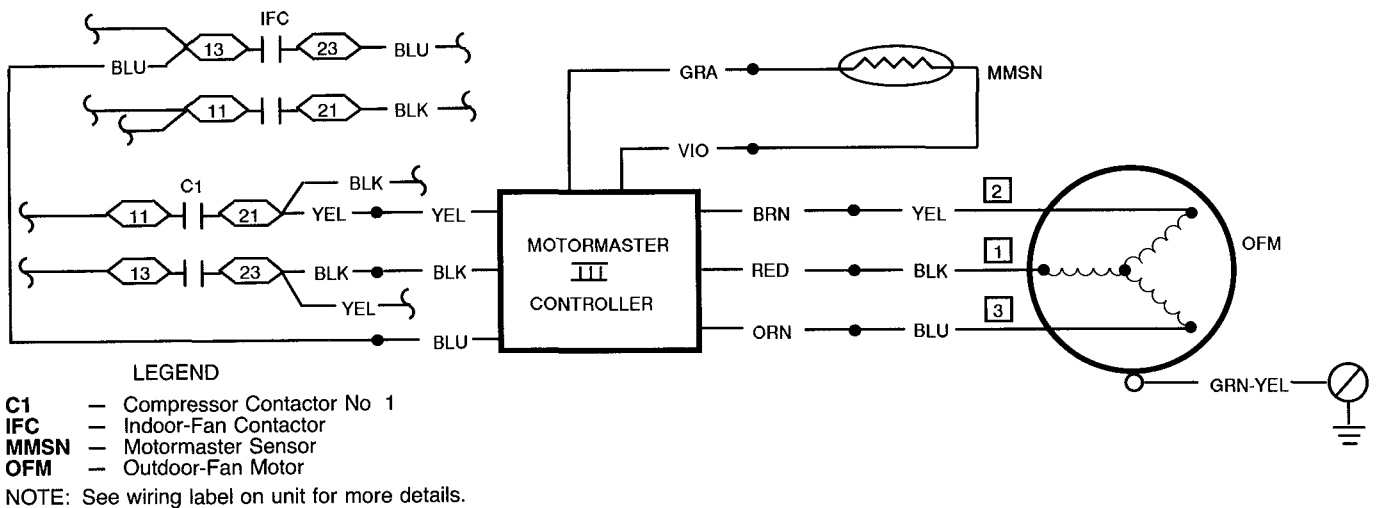

LEGEND

- C1** - Compressor Contactor No 1
 - IFC** - Indoor-Fan Contactor
 - MMSN** - Motormaster Sensor
 - OFM** - Outdoor-Fan Motor
- NOTE: See wiring label on unit for more details.

Fig. 21 - Fan Power Wiring - 48/50TJ008-012 - 208/230 V and 460 V; 60 Hz

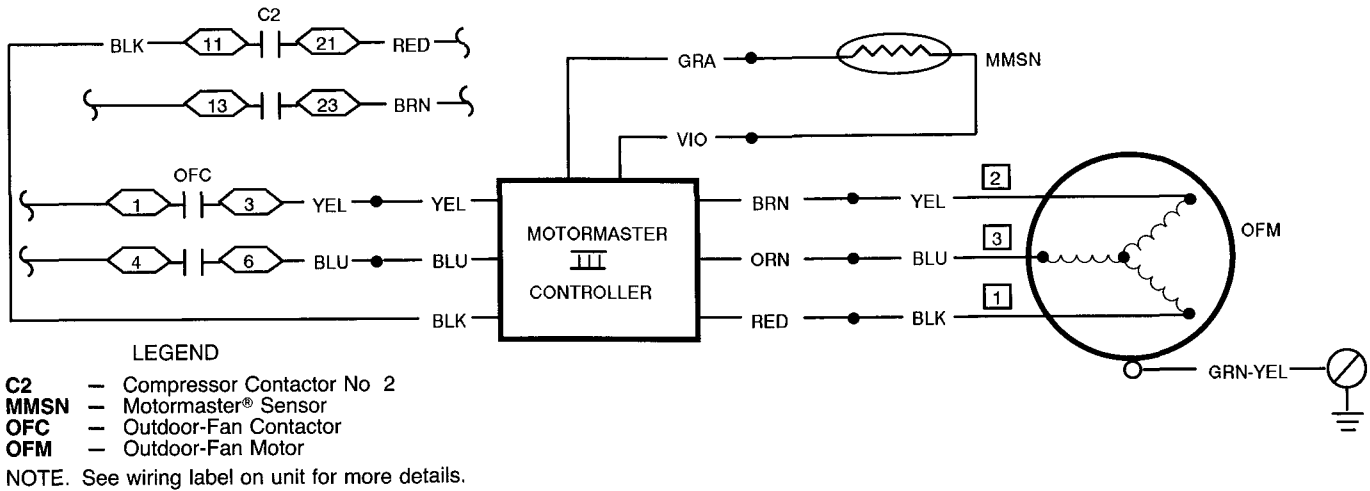

Fig. 22 – Fan Power Wiring – 50HJ014; 50TJ014 – 208/230 V; 60 Hz

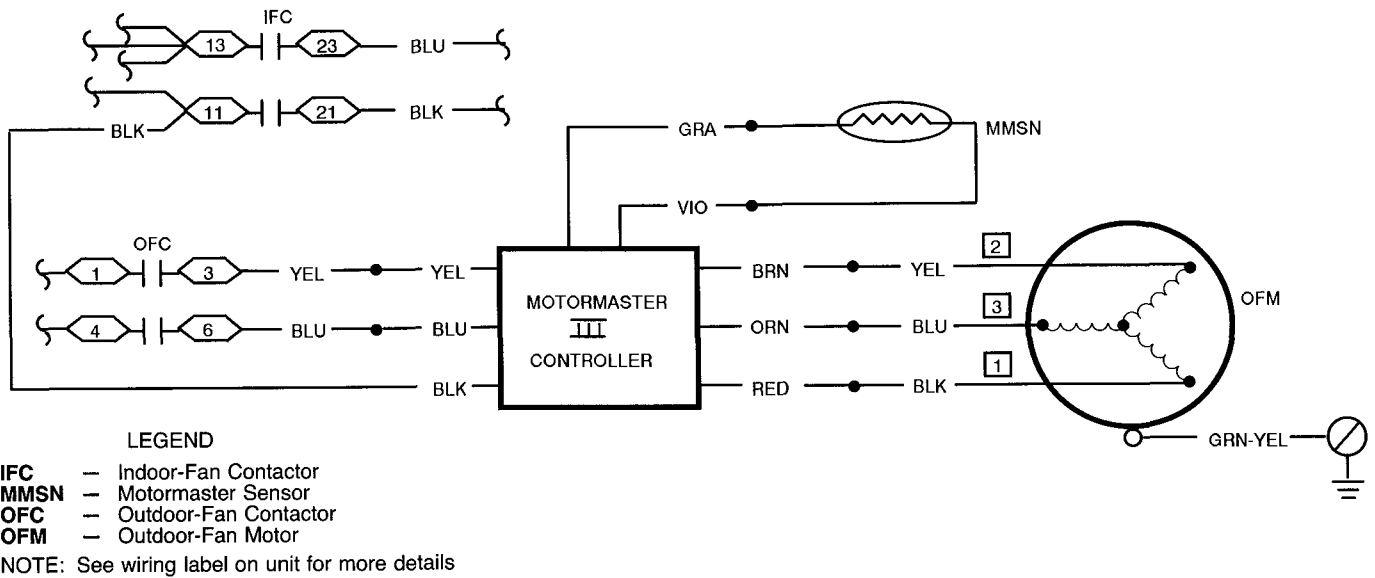

Fig. 23 – Fan Power Wiring 48HJ008-014; 48TJ014 – 208/230 V and 460 V; 60 Hz

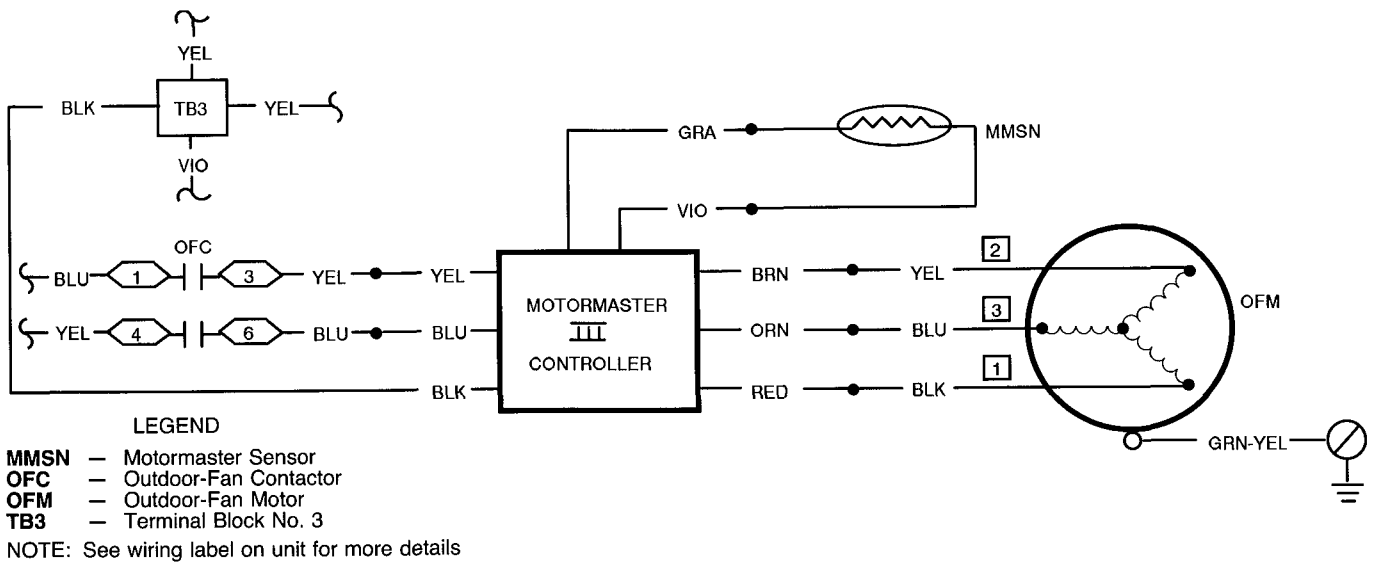

Fig. 24 – Fan Power Wiring – 48/50HJ,TJ008-014 – 575 V; 60 Hz

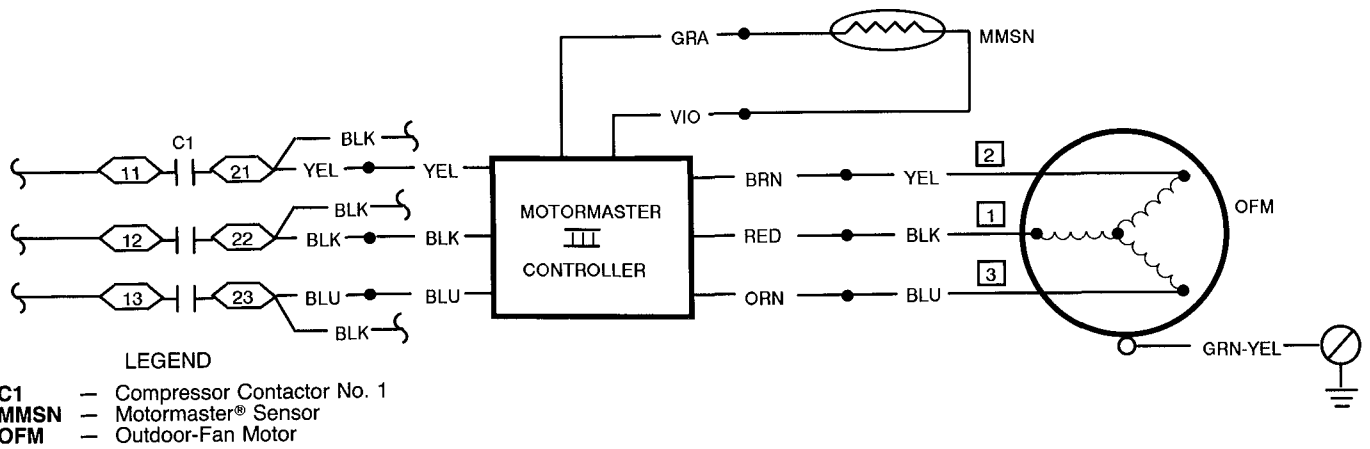

Fig. 25 – Fan Power Wiring – 50TJ008-014 – 220 V and 400 V; 50 Hz

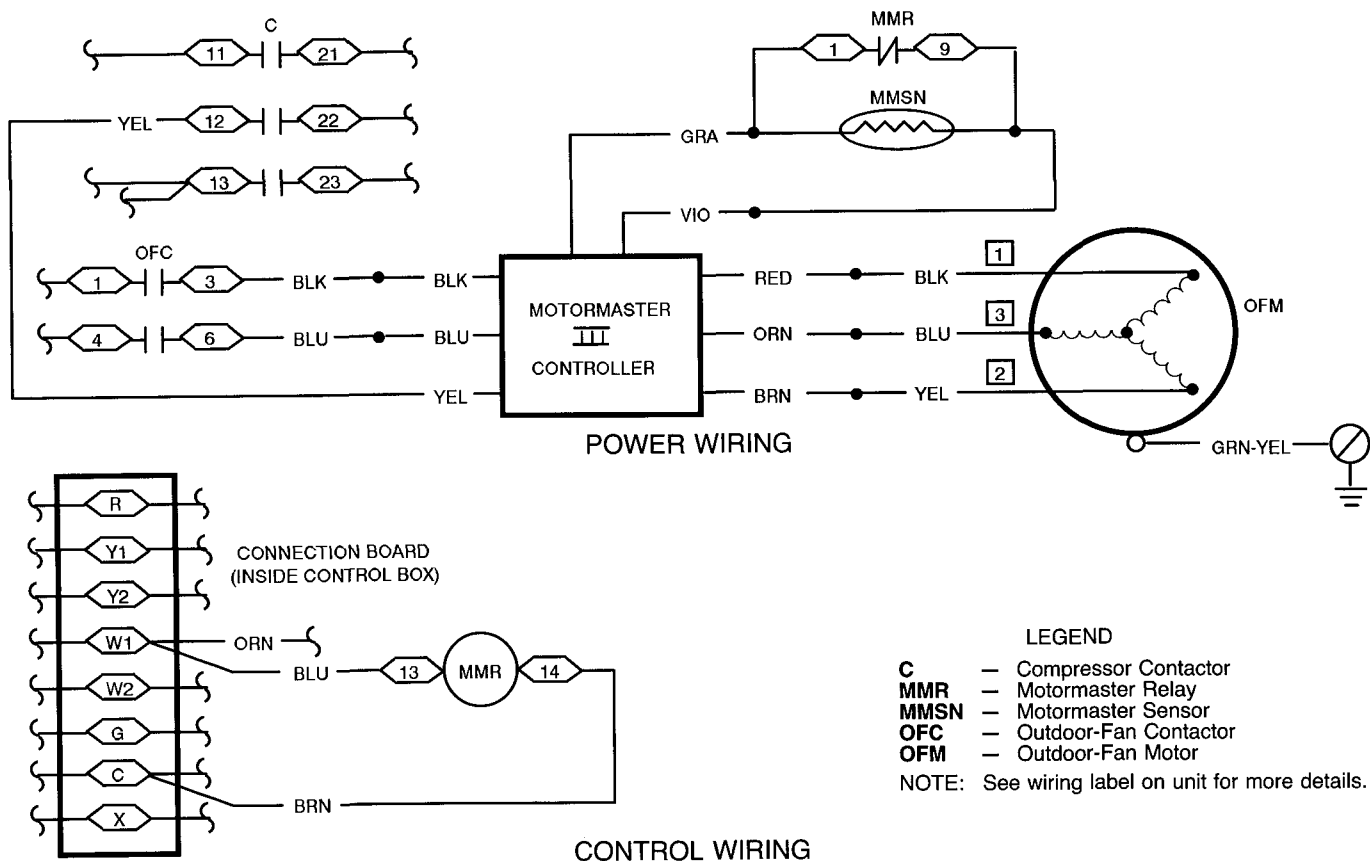
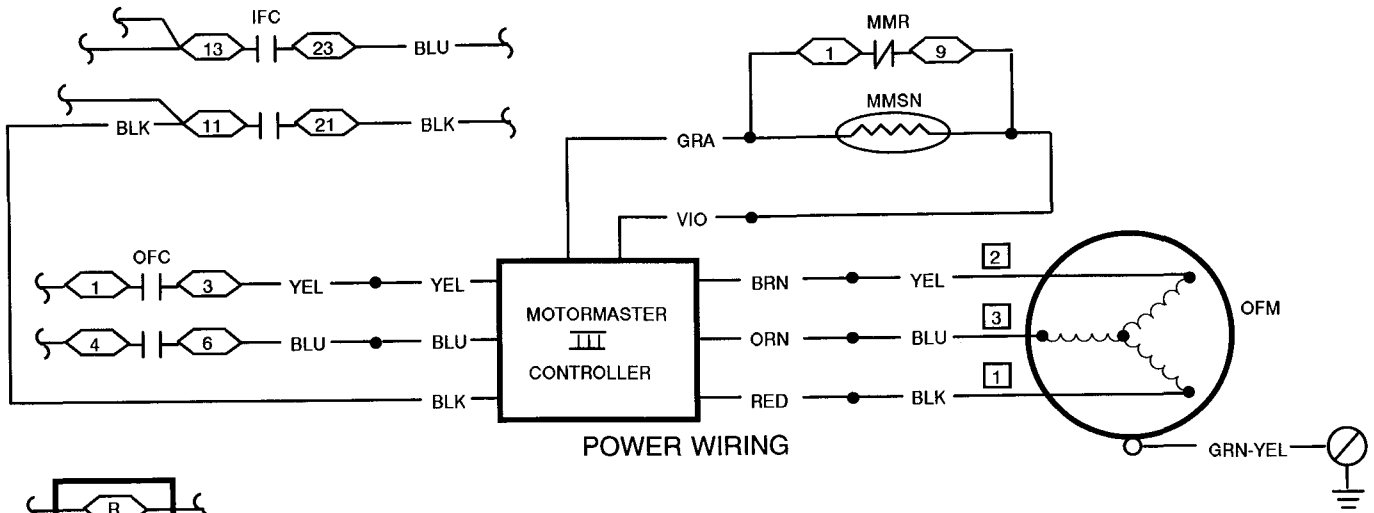
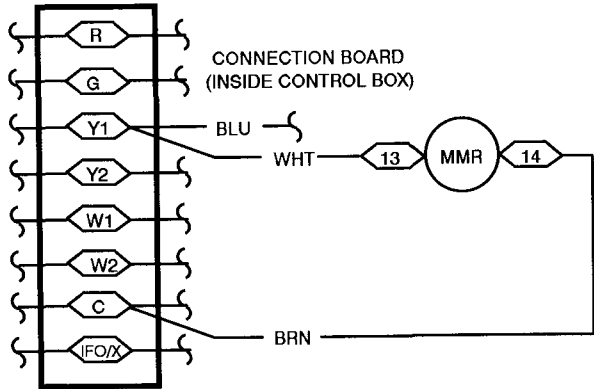

Fig. 26 – Fan Control/Power Wiring – 38AQS008 – 208/230 V and 460 V; 60 Hz



POWER WIRING



CONTROL WIRING

- LEGEND
- IFC - Indoor-Fan Contactor
 - MMR - Motormaster® III Relay
 - MMSN - Motormaster Sensor
 - OFC - Outdoor-Fan Contactor
 - OFM - Outdoor-Fan Motor

NOTE: See wiring label on unit for more details

Fig. 27 - Fan Control/Power Wiring - 50LJQ008-012 - 208/230 V and 460 V; 60 Hz

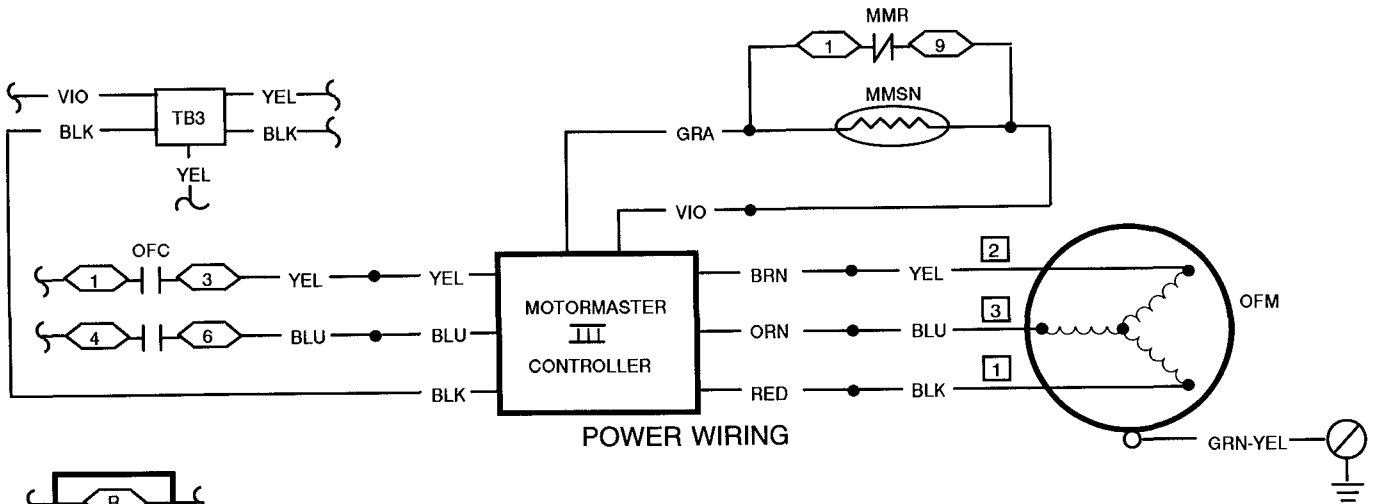

POWER WIRING

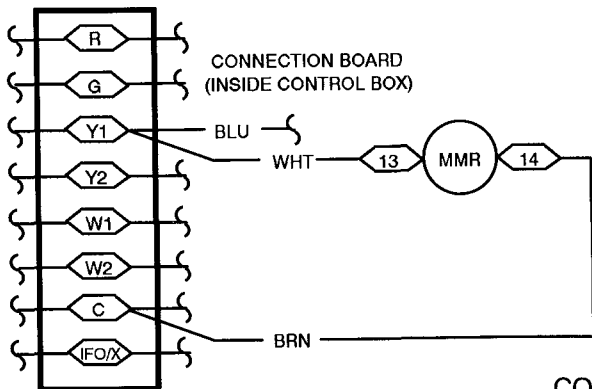

CONTROL WIRING

- LEGEND
- MMR - Motormaster Relay
 - MMSN - Motormaster Sensor
 - OFC - Outdoor-Fan Contactor
 - OFM - Outdoor-Fan Motor
 - TB3 - Terminal Block No. 3

NOTE: See wiring label on unit for more details

Fig. 28 - Fan Control/Power Wiring - 50LJQ008-012 - 575 V; 60 Hz

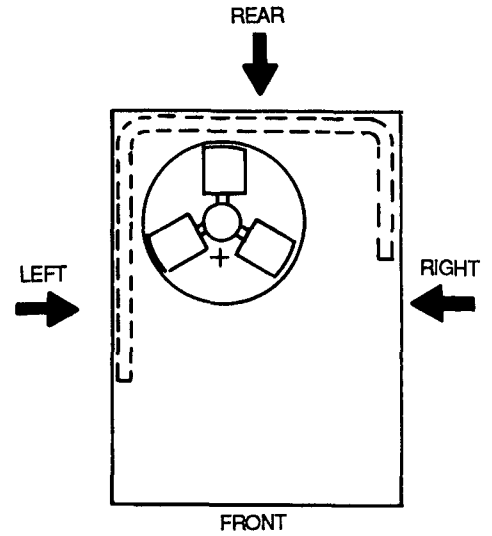
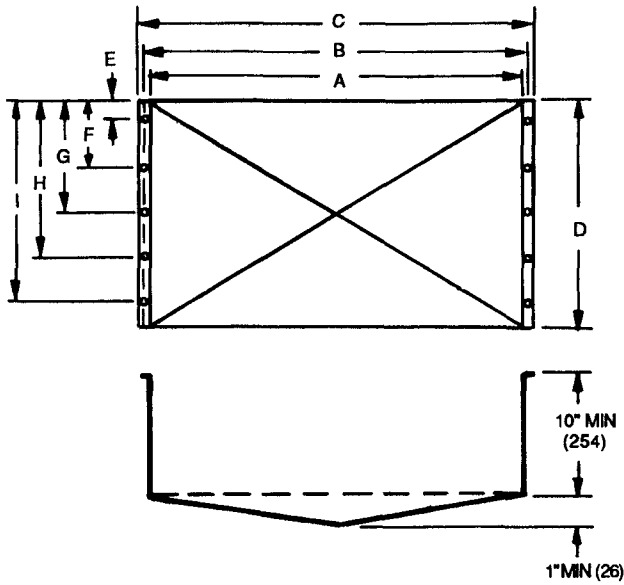

NOTE: Dimensions in () are millimeters.

DIMENSIONS (in.)

LEFT BAFFLE

UNIT 38	A	B	C	D	E	F	G	H	I
AK008; AKS008-012; AQS008	28 ³ / ₄	29 ⁵ / ₈	30 ¹ / ₂	35	2	10	18	26	34
AK012	28 ³ / ₄	29 ⁵ / ₈	30 ¹ / ₂	35	2	10	18	26	34

REAR BAFFLE

UNIT 38	A	B	C	D	E	F	G	H	I
AK008; AKS008-012; AQS008	36 ¹ / ₂	37 ³ / ₈	38 ¹ / ₄	35	2	10	18	26	34
AK012	36 ¹ / ₂	37 ³ / ₈	38 ¹ / ₄	35	2	10	18	26	34

RIGHT BAFFLE

UNIT 38	A	B	C	D	E	F	G	H	I
AK008; AKS008-012; AQS008	9 ¹⁵ / ₁₆	10 ¹³ / ₁₆	11 ¹¹ / ₁₆	35	2	10	18	26	34
AK012	19 ⁷ / ₈	20 ³ / ₄	21 ⁵ / ₈	35	2	10	18	26	34

DIMENSIONS (mm)

LEFT BAFFLE

UNIT 38	A	B	C	D	E	F	G	H	I
AK008; AKS008-012; AQS008	730	752	775	889	51	254	457	660	864
AK012	730	752	775	889	51	254	457	660	864

REAR BAFFLE

UNIT 38	A	B	C	D	E	F	G	H	I
AK008; AKS008-012; AQS008	927	949	972	889	51	254	457	660	864
AK012	927	949	972	889	51	254	457	660	864

RIGHT BAFFLE

UNIT 38	A	B	C	D	E	F	G	H	I
AK008; AKS008-012; AQS008	252	275	297	889	51	254	457	660	864
AK012	505	527	549	889	51	254	457	660	864

Fig. 29 – Wind Baffle Mounting Details, 38AK,AKS,AQS Units

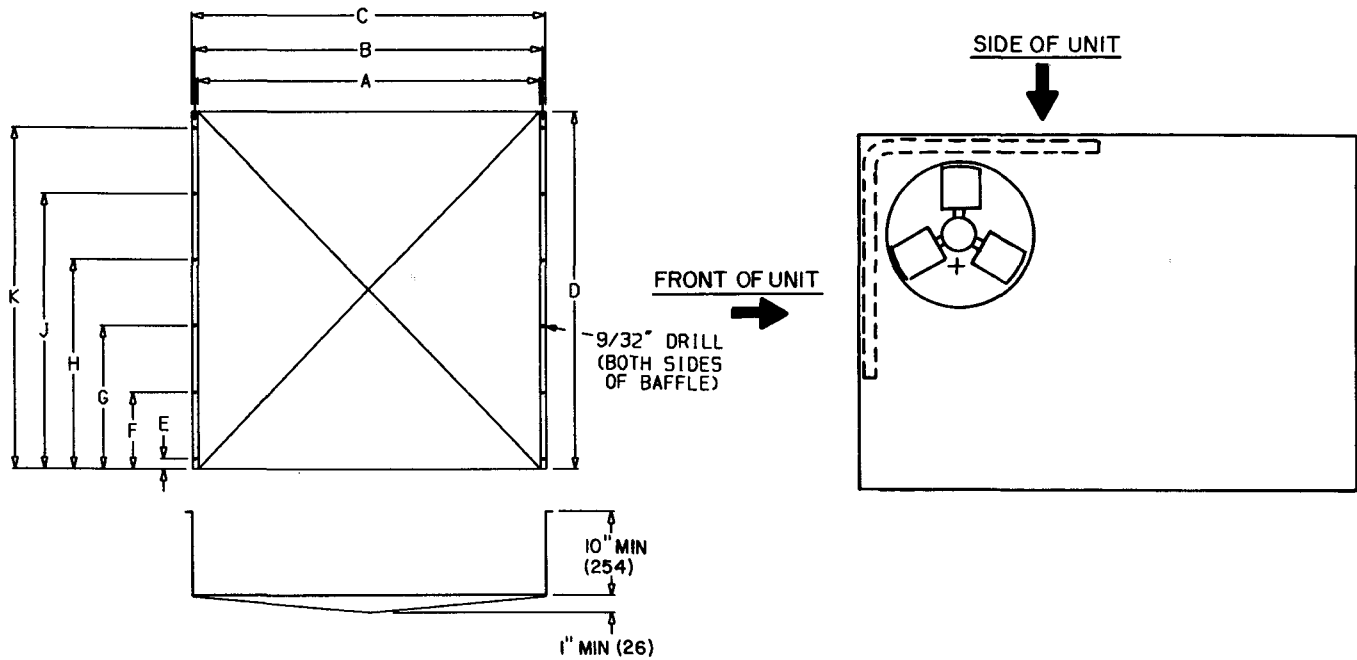

NOTE: Dimensions in () are millimeters

SIDE BAFFLE
DIMENSIONS (in.)

UNIT	A	B	C	D	E	F	G	H	J	K
48/50HJ,TJ008,009; 50LJQ008	43 $\frac{1}{8}$	43 $\frac{7}{8}$	44 $\frac{5}{8}$	35 $\frac{1}{4}$	5 $\frac{7}{8}$	14 $\frac{7}{8}$	22 $\frac{1}{4}$	30 $\frac{1}{2}$	—	—
48/50HJ,TJ012,014; 50LJQ012	43 $\frac{1}{8}$	43 $\frac{7}{8}$	44 $\frac{5}{8}$	43 $\frac{1}{4}$	5 $\frac{7}{8}$	14 $\frac{7}{8}$	22 $\frac{1}{4}$	30 $\frac{1}{2}$	38 $\frac{1}{8}$	—

DIMENSIONS (mm)

UNIT	A	B	C	D	E	F	G	H	J	K
48/50HJ,TJ008,009; 50LJQ008	1096.0	1115.0	1134.0	894.0	150.0	377.0	566.0	774.0	—	—
48/50HJ,TJ012,014; 50LJQ012	1096.0	1115.0	1134.0	1098.0	150.0	377.0	566.0	774.0	967.6	—

FRONT BAFFLE
DIMENSIONS (in)

UNIT	A	B	C	D	E	F	G	H	J	K
48/50HJ008	31 $\frac{3}{4}$	32 $\frac{1}{2}$	33 $\frac{3}{4}$	35 $\frac{1}{4}$	1 $\frac{1}{4}$	9 $\frac{1}{4}$	17 $\frac{1}{4}$	25 $\frac{1}{4}$	33 $\frac{1}{4}$	—
48/50HJ009; 48/50TJ008; 50LJQ008	41 $\frac{5}{8}$	42 $\frac{3}{8}$	43 $\frac{1}{8}$	35 $\frac{1}{4}$	1 $\frac{1}{4}$	9 $\frac{1}{4}$	17 $\frac{1}{4}$	25 $\frac{1}{4}$	33 $\frac{1}{4}$	—
48/50TJ009	16 $\frac{5}{8}$	17 $\frac{3}{8}$	18 $\frac{1}{8}$	35 $\frac{1}{4}$	1 $\frac{1}{4}$	9 $\frac{1}{4}$	17 $\frac{1}{4}$	25 $\frac{1}{4}$	33 $\frac{1}{4}$	—
48/50TJ012	26 $\frac{5}{8}$	27 $\frac{3}{8}$	28 $\frac{1}{8}$	43 $\frac{1}{4}$	1 $\frac{1}{4}$	9 $\frac{1}{4}$	17 $\frac{1}{4}$	25 $\frac{1}{4}$	33 $\frac{1}{4}$	41 $\frac{1}{4}$
48/50HJ012,014; 48/50TJ014; 50LJQ012	41 $\frac{5}{8}$	42 $\frac{3}{8}$	43 $\frac{1}{8}$	43 $\frac{1}{4}$	1 $\frac{1}{4}$	9 $\frac{1}{4}$	17 $\frac{1}{4}$	25 $\frac{1}{4}$	33 $\frac{1}{4}$	41 $\frac{1}{4}$

DIMENSIONS (mm)

UNIT	A	B	C	D	E	F	G	H	J	K
48/50HJ008	805.0	824.0	843.0	894.0	32.0	235.2	438.4	641.6	844.8	—
48/50HJ009; 48/50TJ008; 50LJQ008	1058.0	1077.0	1096.0	894.0	32.0	235.2	438.4	641.6	844.8	—
48/50TJ009	423.0	442.0	461.0	894.0	32.0	235.2	438.4	641.6	844.8	—
48/50TJ012	677.0	696.0	715.0	1098.0	32.0	235.2	438.4	641.6	844.8	1048.0
48/50HJ012,014; 48/50TJ014; 50LJQ012	1058.0	1077.0	1096.0	1098.0	32.0	235.2	438.4	641.6	844.8	1048.0

Fig. 30 – Wind Baffle Mounting Details, 48/50HJ,TJ008-014; 50LJQ008,012

TROUBLESHOOTING

1. The Motormaster® III control must be securely grounded to the cabinet of the unit to function properly.
2. The power frequency switch must be in the correct position for the power supply being used. The control switch must be set at the thermistor setting.
3. Motormaster III controls may be applied only to specially qualified fan motors. Ensure that the proper fan motor has been installed with the Motormaster III control. See Tables 2 and 3.
4. A true RMS (Root Mean Square) meter is required to accurately read the output from the Motormaster III control because of the electronically controlled output voltage.
5. Thermistor sensor lead connections should be carefully rechecked if there is an operational problem. See the thermistor characteristic for sensor 30GT412176 shown in Fig. 31. The controller operates between 1600 ohms and 5800 ohms. At 1600 ohms the controller is at full voltage. At 5800 ohms the output is at a minimum (10% of motor speed).

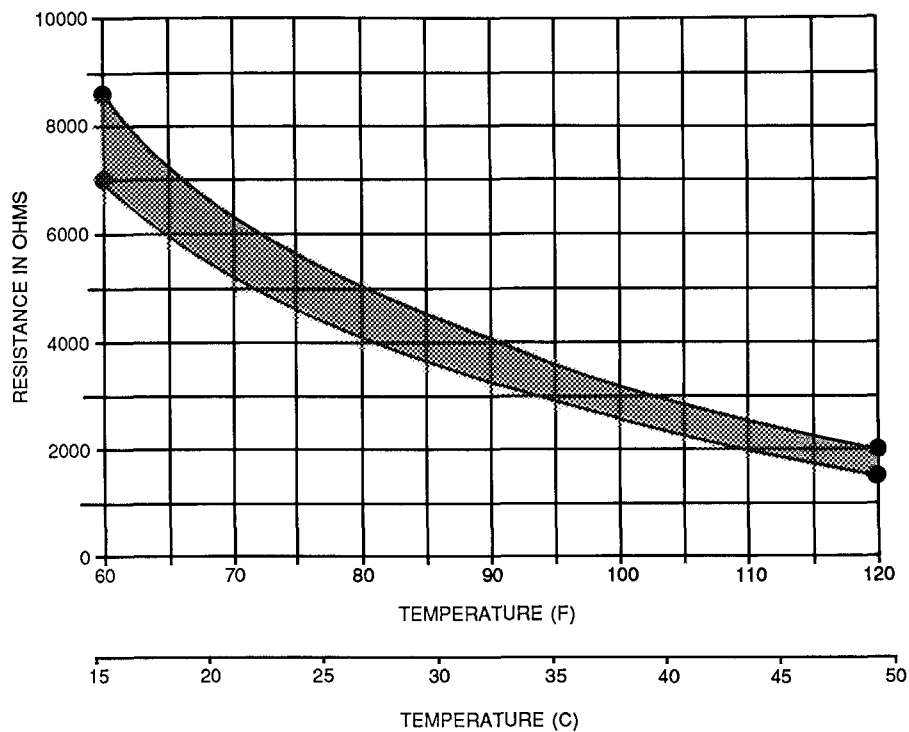

LEGEND

 Tolerance band for allowable Motormaster III resistance values.

Fig. 31 – Thermistor Resistance vs Temperature



BRACKET

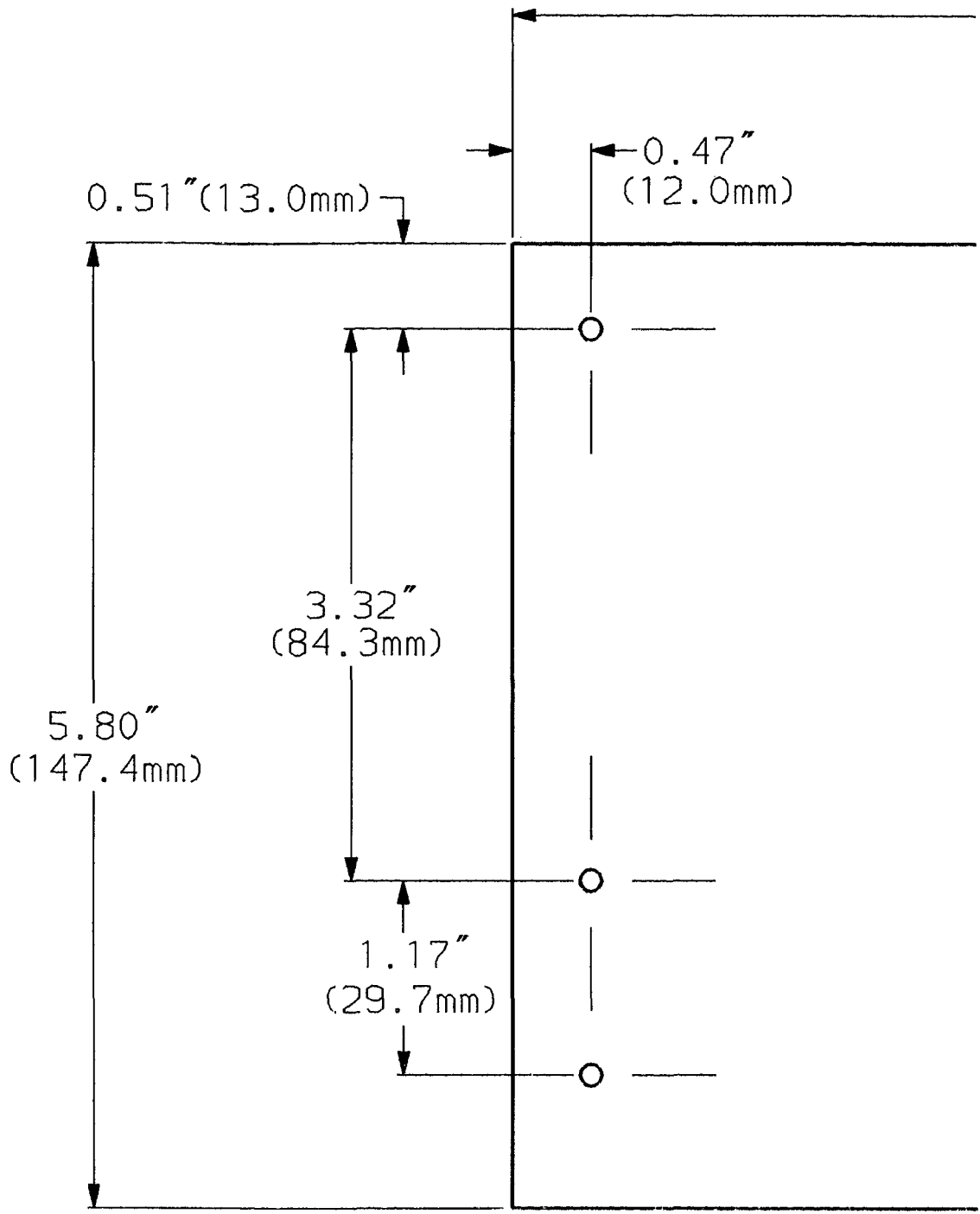
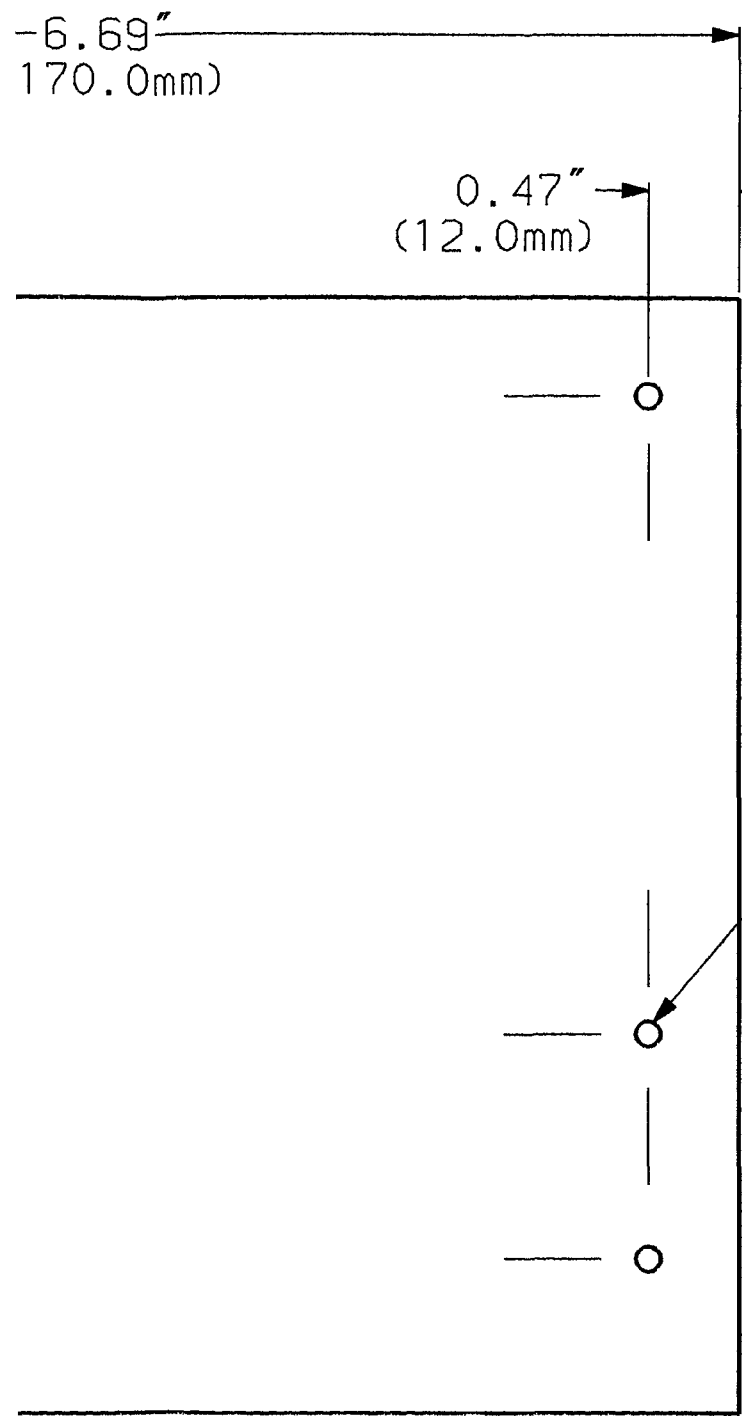

0.130" (3.3mm)
0.134" (3.4mm) DIA
(6 PLACES TYPICAL)

T TEMPLATE

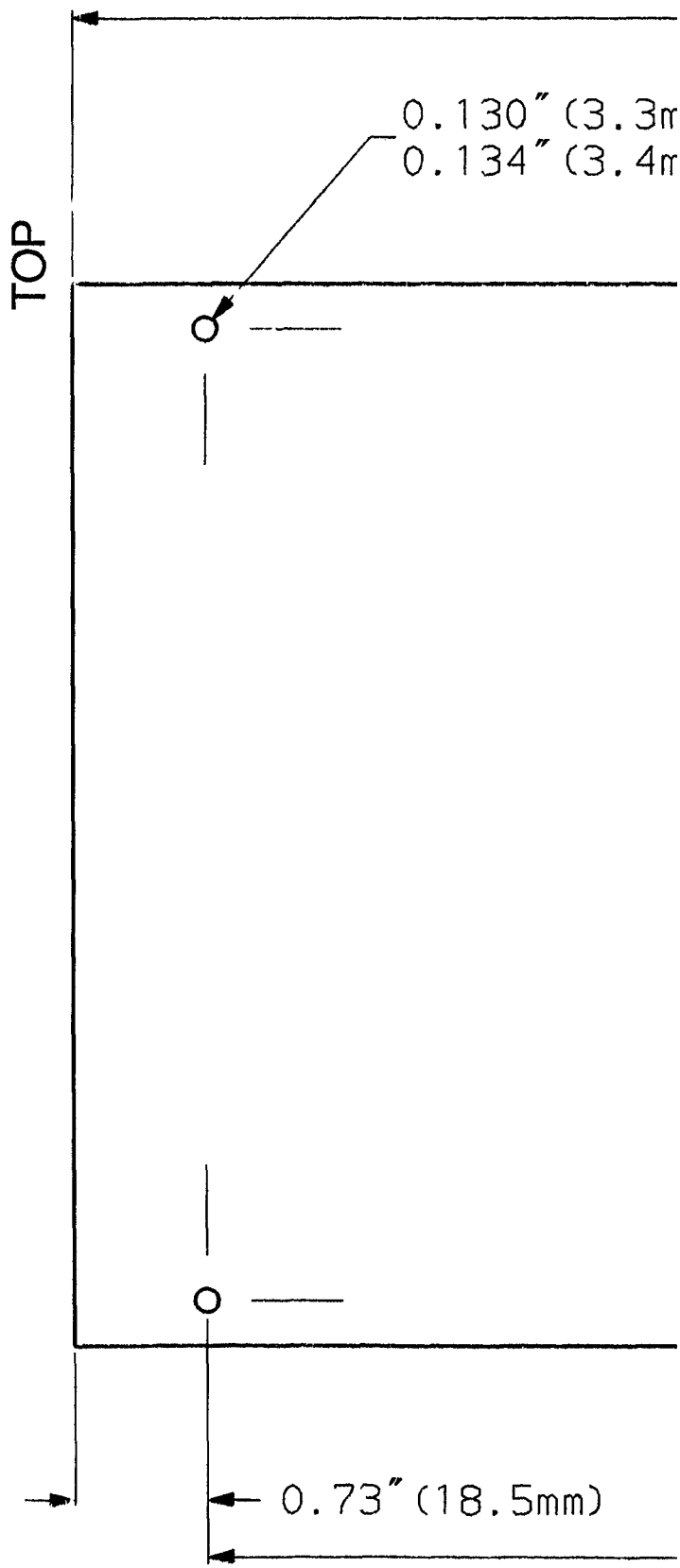

16.05"
(407.7mm)

} DIA (4 PLACES TYPICAL)

MOTORMASTER[®] CONTROLLER TEMPLATE

12.00"
(305.0mm)

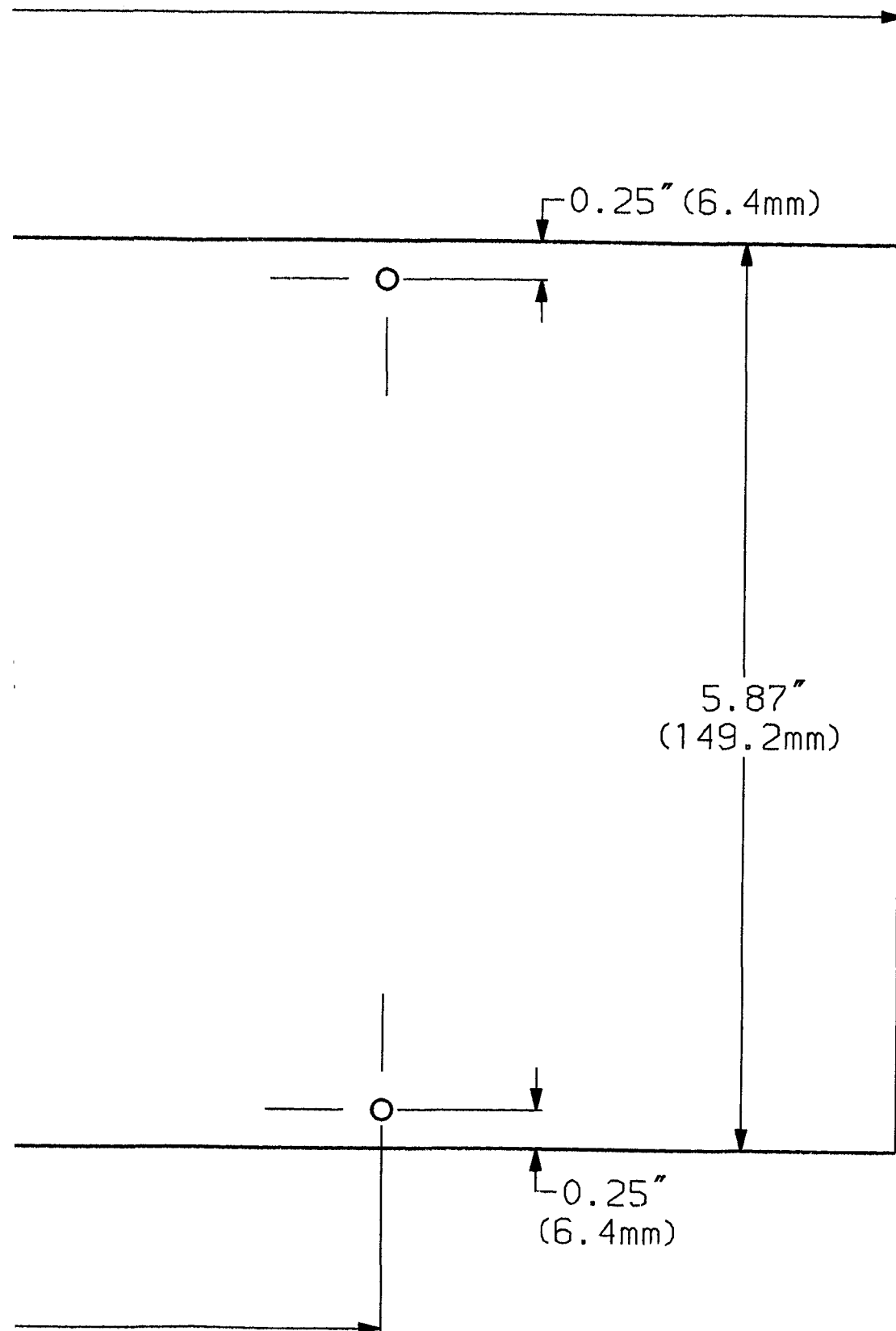

BOTTOM

0.25" (6.4mm)

5.87"
(149.2mm)

0.25"
(6.4mm)

Manufacturer reserves the right to discontinue, or change at any time, specifications or designs without notice and without incurring obligations.

Book	1	1	1	1	4	4	4	4
Tab	1a	1b	3a	5a	2a	5a	6a	6b