

SHARP®

VX-1652H
VX-2652H

ELECTRONIC PRINTING CALCULATOR
CALCULADORA IMPRESORA ELECTRÓNICA

OPERATION MANUAL
MANUAL DE MANEJO

ENGLISH	Page 2
CALCULATION EXAMPLES	Page 18
ESPAÑOL	Página 10
EJEMPLOS DE CALCULOS	Página 18

This device complies with Part 15 of the FCC Rules. Operation is subject to the following two conditions: (1) This device may not cause harmful interference, and (2) this device must accept any interference received, including interference that may cause undesired operation.

WARNING - FCC Regulations state that any unauthorized changes or modifications to this equipment not expressly approved by the manufacturer could void the user's authority to operate this equipment.

Note: This equipment has been tested and found to comply with the limits for a Class B digital device, pursuant to Part 15 of the FCC Rules.

These limits are designed to provide reasonable protection against harmful interference in a residential installation. This equipment generates, uses, and can radiate radio frequency energy and, if not installed and used in accordance with the instructions, may cause harmful interference to radio communications. However, there is no guarantee that interference will not occur in a particular installation. If this equipment does cause harmful interference to radio or television reception, which can be determined by turning the equipment off and on, the user is encouraged to try to correct the interference by one or more of the following measures:

- Reorient or relocate the receiving antenna.
- Increase the separation between the equipment and receiver.
- Connect the equipment into an outlet on a circuit different from that to which the receiver is connected.
- Consult the dealer or an experienced radio/TV technician for help.

Caution!

The socket outlet shall be installed near the equipment and shall be easily accessible.

Aviso!

El tomacorriente debe estar instalado cerca del equipo y debe quedar bien accesible.

INTRODUCTION

Thank you for your purchase of the SHARP electronic calculator, model VX-1652H/2652H. Your SHARP calculator is specially designed to save work and increase efficiency in all business applications and general office calculations. Careful reading of this manual will enable you to use your new SHARP calculator to its fullest capability.

OPERATIONAL NOTES

To insure trouble-free operation of your SHARP calculator, we recommend the following:

1. The calculator should be kept in areas free from extreme temperature changes, moisture, and dust.
2. A soft, dry cloth should be used to clean the calculator. Do not use solvents or a wet cloth.
3. Since this product is not waterproof, do not use it or store it where fluids, for example water, can splash onto it. Raindrops, water spray, juice, coffee, steam, perspiration, etc. will also cause malfunction.
4. If you are not going to use the calculator for a time period, please pull out the power cord to cut electricity completely. In this case, the presently stored tax/discount rate will be cleared.
5. If service should be required on this equipment, use only a SHARP servicing dealer, a SHARP approved service facility or SHARP repair service where available.
6. Do not wind the AC cord around the body or otherwise forcibly bend or twist it.

WARNING

THE VOLTAGE USED MUST BE THE SAME AS SPECIFIED ON THIS CALCULATOR. USING THIS CALCULATOR WITH A VOLTAGE HIGHER THAN THAT SPECIFIED IS DANGEROUS AND MAY RESULT IN A FIRE OR OTHER TYPE OF ACCIDENT CAUSING DAMAGE. SHARP WILL NOT BE HELD RESPONSIBLE FOR ANY DAMAGE RESULTING FROM USE OF THIS CALCULATOR WITH OTHER THAN THE SPECIFIED VOLTAGE.

CONTENTS

	Page
• OPERATING CONTROLS	3
• INK RIBBON REPLACEMENT	7
• PAPER ROLL REPLACEMENT	8
• ERRORS	9
• SPECIFICATIONS	9
• CALCULATION EXAMPLES	18
• TAX RATE CALCULATIONS	31
• DISCOUNT RATE CALCULATION	33

OPERATING CONTROLS

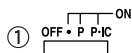

POWER SWITCH; PRINT / ITEM COUNT MODE SELECTOR:

“OFF”: Power OFF.

“•”: Power ON. Set to the non-print mode.

(“•••...•••-P” will be printed.)

“P”: Power ON. Set to the print mode.

(“•••...•••+P” will be printed.)

“P•IC”: Power ON. Set to the print and item count mode.

The counter will count the number of times that $\boxed{\pm}$ has been pressed in addition.

- Notes:
- Each time $\boxed{-}$ is used in subtraction, 1 will be subtracted from the count.
 - The count is printed when the calculated result is obtained.
 - Pressing of $\boxed{*}$, $\boxed{\times}$ or $\boxed{+}$ clears the counter.
 - The counter has a maximum capacity of 3 digits (up to ± 999). If the count exceeds the maximum, the counter will recount from zero.

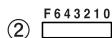

DECIMAL SELECTOR:





Presets the number of decimal places in the answer.



In the “F” position, the answer is displayed in the floating decimal system.

③ **ROUNDING SELECTOR:**

Example: Set decimal selector to “2”.

 $4 \div 9 = 0.444 \dots$, $5 \div 9 = 0.555 \dots$



	4  9 	5  9 
↑	0.45	0.56
5/4	0.44	0.56
↓	0.44	0.55

Note: The decimal point floats during successive calculation by the use of  or .

If the decimal selector is set to “F” then the answer is always rounded down (↓).



④ **CONSTANT / ADD MODE SELECTOR:**

“K” : The following constant functions will be performed:

Multiplication: The calculator will automatically remember the first number entered (the multiplicand) and  instruction.**Division:** The calculator will automatically remember the second number entered (the divisor) and  instruction.





“•”: Neutral

“A”: Use of the Add mode permits addition and subtraction of numbers without entry of the decimal point. When the Add mode is activated, the decimal point is automatically positioned according to the decimal selector setting.

Use of , , and  will automatically override the Add mode and decimally correct answers will be printed at the preset decimal position.⑤ **GRAND TOTAL MODE SELECTOR:**

“GT”: This selector will accumulate the following:

(“ * +” will be printed.)

1. Addition and subtraction totals obtained with .
2. Product and quotient totals obtained with  or .
3. Answers obtained with  or .

“•”: Neutral

⑥ **PAPER FEED KEY**⑦ **LAST DIGIT CORRECTION KEY**⑧ **GRAND TOTAL KEY:**



Prints and clears the “GT” memory contents.

⑨ 

NON-ADD / SUBTOTAL KEY:

Non-Add – When this key is pressed right after entry of a number in the Print mode, the entry is printed on the left-hand side with “#”.

This key is used to print out numbers not subject to calculations such as codes, dates, etc.

Subtotal – Used to get subtotal(s) of additions and/or subtractions. When pressed following  or , the subtotal is printed with “◇” and the calculation may be continued.

By pressing this key even in the Non-print mode, the displayed number is printed with “P”.

⑩ 

TOTAL KEY:

Prints the total of addition and subtraction with “*”.

This key also serves as a clear key for the calculation register and resets an error condition.

⑪ 

CLEAR ENTRY KEY:

Clears numbers entered prior to use of a function key.

Also used to clear an overflow error caused by an entry.

⑫ 

FIRST RECALL MEMORY KEY

⑬ 

FIRST RECALL AND CLEAR MEMORY KEY

⑭ 

MULTIPLE USE KEY:

Performs mark-ups, percent change and automatic add-on/discount.

⑮ 

CHANGE SIGN KEY:

Changes the algebraic sign of a number (i.e. positive to negative or negative to positive).

⑯ 

TAX-INCLUDING KEY:

This key is used for calculations with the tax/discount rate.

⑰ 

STORE KEY:

This key is used to store the tax/discount rate.

- A maximum of 4 digits can be stored (decimal point is not counted as a digit).
- To store a discount rate, press  first.
- Only one rate can be stored. If you enter a new rate, the previous rate will be cleared.

⑱ 

SECOND RECALL MEMORY KEY

⑲ 

SECOND RECALL AND CLEAR MEMORY KEY

⑳ DISPLAY

Display format:

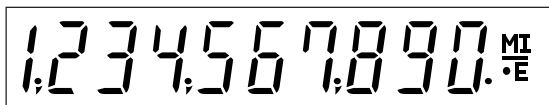

(VX-1652H)

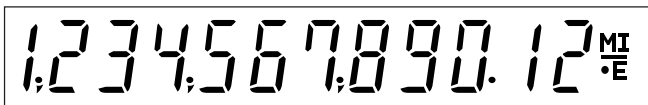

(VX-2652H)

Symbols:

M : First memory symbol

Appears when a number has been stored in First memory.

I : Second memory symbol

Appears when a number has been stored in Second memory.

- : Minus symbol

Appears when a number is a negative.

E : Error symbol

Appears when an overflow or other error is detected.

• : Grand total memory symbol

Appears when a number is in the grand total memory.

INK RIBBON REPLACEMENT

1. Remove the paper roll from the calculator. (Tear the paper and remove it from the print mechanism by using )
2. **Set the power switch to OFF.**
Make sure that the print wheel has stopped.
3. Remove the printer cover by sliding it towards the back of the calculator. (Fig. 1)
4. Remove the used ribbon.
5. Install the new ribbon.
6. With the black side of the ribbon facing upwards, place one of the reels on the reel shaft on the right. (Fig. 2) Make sure that the reel is securely in place.
7. Thread the ribbon around the outside of the metal guides. (Fig. 3)
8. Take up any slack by manually turning one of the reels.
9. Replace the printer cover.
10. Replace the paper roll.

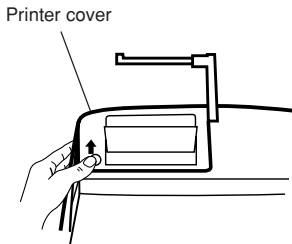

Fig. 1

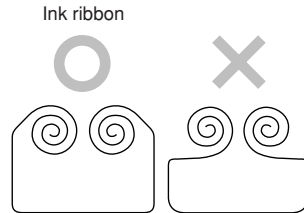

Fig. 2

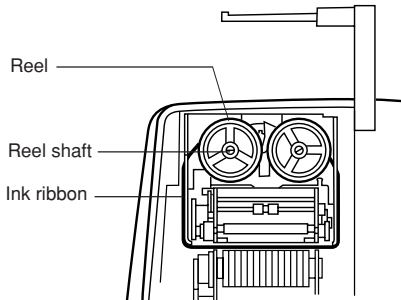

Fig. 3

PAPER ROLL REPLACEMENT

1. Lift the paper holder up. (Fig. 1)
2. Fold the leading edge of the paper roll 3 to 5 cm. (Do not fold it slantwise.) (Fig. 2)
3. Insert the paper roll from the left side of the paper holder and make sure the paper roll is set in the proper direction (with the paper feeding from the bottom). (Fig. 3)
4. Insert the leading edge of the paper into the opening directly behind the print mechanism. (Fig. 4)
5. Press the paper feed key and feed the paper under the edge of the paper cutter. (Fig. 5)

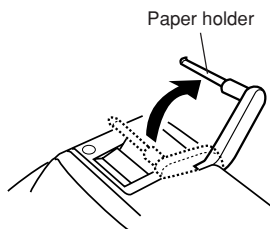

Fig. 1

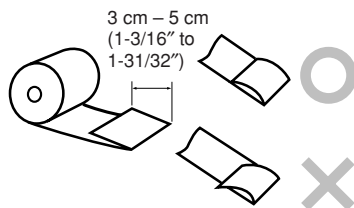

Fig. 2

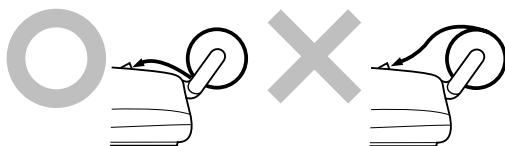

Fig. 3

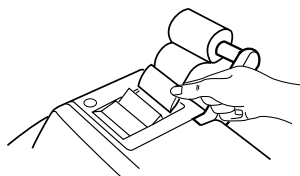

Fig. 4

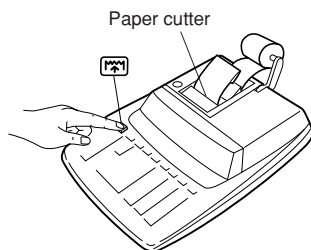

Fig. 5

DO NOT PULL THE PAPER BACKWARDS AS THIS MAY DAMAGE THE PRINTER MECHANISM.

ERRORS

There are several situations which will cause an overflow or an error condition. When this occurs, the error symbol "E" will be displayed and all keys will electronically lock.

The contents of the memory at the time of the error are retained.

If an "0•E" is displayed at the time of the error, $\boxed{[*]}$ must be used to clear the calculator.

If an "E" with any numerals except zero is displayed, the error may be cleared with $\boxed{[CE]}$ or $\boxed{[\rightarrow]}$ and the calculation can still be continued.

Error conditions:

1. Entry of more than 10 digits or 9 decimals. (VX-1652H)
Entry of more than 12 digits or 11 decimals. (VX-2652H)
This error can be cleared with $\boxed{[CE]}$ or $\boxed{[\rightarrow]}$.
2. When the integer portion of an answer exceeds 10 digits. (VX-1652H)
When the integer portion of an answer exceeds 12 digits. (VX-2652H)
3. When the integer portion of the contents of the memory exceeds 10 digits. (VX-1652H)
(Ex. $\boxed{[*M]}$ 9999999999 $\boxed{[M+]}$ 1 $\boxed{[M+]}$)
When the integer portion of the contents of the memory exceeds 12 digits. (VX-2652H)
(Ex. $\boxed{[*M]}$ 999999999999 $\boxed{[M+]}$ 1 $\boxed{[M+]}$)
4. When any number is divided by zero. (Ex. $5 \boxed{[\div]} 0 \boxed{[=]}$)

SPECIFICATIONS

Operating capacity:	10 digits (VX-1652H) 12 digits (VX-2652H)
Power source:	AC: 120V, 60Hz
Calculations:	Four arithmetic calculations, constant multiplication and division, power calculation, add-on/discount calculation, repeat addition and subtraction, reciprocal calculation, grand total calculation, item count calculation, markup calculation, memory calculation, etc.

PRINTING SECTION

Printer:	Mechanical printer
Printing speed:	Approx. 4.3 lines/sec.
Printing paper:	57 mm (2-1/4") ~ 58 mm (2-9/32") wide 80 mm (3-5/32") in diameter (max.)
Operation temperature:	0°C ~ 40°C (32°F ~ 104°F)
Power consumption:	126 mA
Dimensions:	250 mm (W) × 345 mm (D) × 78 mm (H) 9-27/32" (W) × 13-19/32" (D) × 3-1/16" (H)
Weight:	Approx. 2.0 kg (4.41 lb.)
Accessories:	1 paper roll, 1 ink ribbon and operation manual

INTRODUCCION

Muchísimas gracias por haber adquirido la calculadora electrónica de SHARP modelo VX-1652H/2652H. La presente calculadora ha sido expresamente concebida con el fin de ahorrarle trabajo y lograr una mayor eficacia en todas sus aplicaciones de negocios y cálculos generales de oficina. Una atenta lectura del presente manual le permitirá usar su nueva calculadora SHARP al máximo de su capacidad.

NOTAS AL MANEJARLA

A fin de que su calculadora SHARP funcione sin averías, le recomendamos lo siguiente:

1. Evite dejar la calculadora en ambientes en que haya cambios de temperatura, humedad y polvo bastante notables.
2. Al limpiar la calculadora, utilice un paño suave y seco. No use disolventes ni tampoco un paño húmedo.
3. Debido a que este producto no es a prueba de agua, no deberá ser utilizado o guardado en lugares donde pudiera ser salpicado por líquidos, por ejemplo agua. Gotas de lluvia, salpicaduras de agua, jugos o zumos, café, vapor, transpiración, etc. también perjudican el funcionamiento del producto.
4. Si no va a utilizar la calculadora durante algún tiempo, desconecte el cable de alimentación para cortar completamente la electricidad. En este caso, el tipo de impuesto/descuento actualmente almacenado se borrará.
5. Si se requiere algún servicio técnico o reparación en este equipo, diríjase sólo a un distribuidor SHARP de reparaciones, a un centro de servicio autorizado por SHARP o a un centro de reparaciones SHARP cercano a su localidad.
6. No bobine el cable de CA alrededor de la calculadora, y no lo doble o retuerza a la fuerza.

AVISO

EL VOLTAJE USADO DEBE SER EL MISMO QUE EL ESPECIFICADO EN ESTA CALCULADORA. USAR ESTA CALCULADORA CON UN VOLTAJE SUPERIOR AL ESPECIFICADO RESULTA PELIGROSO Y PUEDE CAUSAR UN INCENDIO U OTRO TIPO DE ACCIDENTE. SHARP NO SE HACE RESPONSABLE DE NINGUN DAÑO DEBIDO AL USO DE ESTA CALCULADORA CON UN VOLTAJE DIFERENTE DEL ESPECIFICADO.

INDICE

	Página
• CONTROLES DE FUNCIONAMIENTO	11
• CAMBIO DE LA CINTA ENTINTADA	15
• CAMBIO DEL ROLLO DEL PAPEL	16
• ERRORES	17
• ESPECIFICACIONES TECNICAS	17
• EJEMPLOS DE CALCULOS	18
• CALCULOS CON EL TIPO DE IMPUESTO	31
• CALCUL CON EL TIPO DE DESCUENTO	33

CONTROLES DE FUNCIONAMIENTO

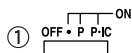

INTERRUPTOR DE CORRIENTE; SELECTOR DEL MODO DE IMPRESION / MODO PARA CONTAR ARTICULOS:

“OFF”: Apagado (OFF)

“•”: Encendido (ON). Fija el modo de no impresión.
(Se imprimirá “••• ... ••• -P”.)

“P”: Encendido (ON). Fija el modo de impresión.
(Se imprimirá “••• ... ••• +P”.)

“P•IC”: Encendido (ON). Fija el modo de impresión y de cuenta de artículos.

El contador contará las veces que se ha apretado $\boxed{\pm}$ en la suma.

Notas: • Cada vez que se use $\boxed{-=}$ en la resta, se restará 1 de la cuenta.

• La cuenta queda impresa cuando se obtiene el resultado calculado.

• Al apretar $\boxed{*}$, $\boxed{\times}$ o $\boxed{\div}$ se borra el contenido del contador.

• El contador tiene una capacidad de un máximo de 3 cifras (hasta ± 999). Si la cuenta excede el máximo, el contador vuelve a contar partiendo de cero.

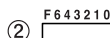

SELECTOR DECIMAL:







Prefija el número de lugares decimales de la respuesta.



En la posición “F”, la respuesta aparecerá en la exhibición en el sistema decimal flotante.

③ **SELECTOR DE REDONDEO:**

Ejemplo: Fija el selector decimal en “2”.

 $4 \div 9 = 0,444 \dots$, $5 \div 9 = 0,555 \dots$

	4  9 	5  9 
	0.45	0.56
5/4	0.44	0.56
	0.44	0.55

Nota: El punto (= coma) decimal flota mientras se hacen cálculos sucesivos usando  o .

Si el selector decimal se coloca en “F”, la respuesta siempre se redondea por defecto ().

④ **SELECTOR DEL MODO DE CONSTANTE / SUMA:**



“K” : Se podrán realizar las siguientes funciones de constantes:

Multiplicación: La calculadora retendrá automáticamente el primer factor registrado (el multiplicando) y la instrucción .

División: La calculadora retendrá automáticamente el segundo factor registrado (el divisor) y la instrucción .

“•”: Posición neutra.

“A”: Utilizando el modo de suma se pueden sumar y restar números sin registrar el punto decimal. Cuando se activa el modo de suma, el punto decimal se coloca automáticamente de acuerdo con el ajuste del selector decimal.

El uso de , , y  desactivará automáticamente el modo de suma y las respuestas decimalmente correctas se imprimirán en la posición decimal prefijada.

⑤ **SELECTOR DEL MODO DE TOTAL GLOBAL:**

“GT”: Este selector hará que se acumule lo siguiente:

(Se imprimirá “* +”.)

1. Totales de suma y resta obtenidos con .2. Totales de productos y cocientes obtenidos con  o .3. Resultados obtenidos con  o .

“•”: Posición neutra, total global, desactivada.

⑥ **TECLA DE AVANCE DEL PAPEL**⑦ **TECLA DE CORRECCION DE LA ULTIMA CIFRA**⑧ **TECLA DE TOTAL GLOBAL:**



Imprime y borra el contenido de la memoria de total global “GT”.

9 

TECLA DE NO SUMA / TOTAL PARCIAL:

No-suma – Cuando se aprieta esta tecla inmediatamente después de haber ingresado un número en el modo de impresión, el número registrado se imprime a la izquierda, junto con “#”. Esta tecla se usa para imprimir números que no están sujetos a cálculos como, por ejemplo, códigos, fechas, etc.

Total parcial – Se usa para obtener uno o varios totales parciales de sumas y/o restas.

Cuando se aprieta a continuación de  o , se imprimirá el total parcial junto con “◇”, pudiéndose seguir con los cálculos.

Al apretar esta tecla, incluso en el modo de no impresión, se imprimirá el número que aparece en la exhibición con “P”.

10 

TECLA DE TOTAL:

Imprime el total de la suma y resta con “*”. Esta tecla también sirve de tecla de borrado para los registros de cálculos, y anula un estado de error.

11 

TECLA DE BORRADO DE ENTRADAS:

Sirve para cancelar un número introducido antes de utilizar una tecla de función. Se usa también para cancelar un error por exceso de capacidad causado por una entrada.

12 

TECLA DE RECUPERACIÓN DE LA PRIMERA MEMORIA

13 

TECLA DE RECUPERACIÓN Y BORRADO DE LA PRIMERA MEMORIA

14 

TECLA DE USO MULTIPLE:

Se usa para llevar a cabo aumentos, cambios de porcentaje y recargos/descuentos automáticos.

15 

TECLA DE CAMBIO DE SIGNO:

Cambia el signo algebraico de un número (es decir, de positivo a negativo o de negativo a positivo).

16 

TECLA DE INCLUSION DE IMPUESTO:

Esta tecla se usa para hacer cálculos con el tipo de impuesto/descuento.

⑰ **STR** **TECLA DE ALMACENAMIENTO:**

Esta tecla se usa para almacenar el tipo de impuesto/descuento.

- Se puede almacenar un máximo de 4 dígitos (el punto decimal no cuenta como dígito).
- Para almacenar el tipo de descuento, apriete $\frac{+}{-}$ primero.
- Sólo puede almacenar un tipo. Si introduce un nuevo tipo, borrará el anterior.

⑱ **◊I** **TECLA DE RECUPERACIÓN DE LA SEGUNDA MEMORIA**

⑲ ***I** **TECLA DE RECUPERACIÓN Y BORRADO DE LA SEGUNDA MEMORIA**

⑳ **EXHIBICION**

Formato de la exhibición:

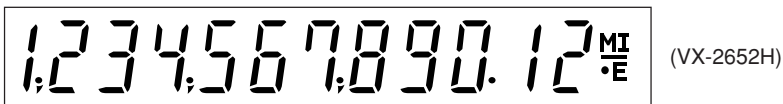
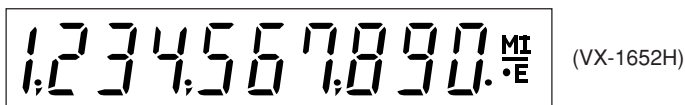

Símbolos:

M : **Símbolo de la primera memoria**

Aparece cuando se ha almacenado un número en la primera memoria.

I : **Símbolo de la segunda memoria**

Aparece cuando se ha almacenado un número en la segunda memoria.

- : **Símbolo menos**

Aparece cuando el número es negativo.

E : **Símbolo de error**

Aparece cuando se detecta un error o se supera la capacidad.

• : **Símbolo del total global de la memoria**

Aparece cuando un número está en la memoria de total global.

CAMBIO DE LA CINTA ENTINTADA

1. Quitar el rollo de papel de la calculadora. (Cortar el papel y sacarlo del mecanismo impresor usando )
2. Colocar el interruptor de corriente en la posición marcada OFF. **Asegurarse de que la rueda de impresión se haya detenido.**
3. Quitar la tapa de la impresora deslizando hacia la parte trasera de la calculadora. (Fig. 1)
4. Quitar la cinta usada.
5. Instalar la cinta nueva.
6. Con el lado negro de la cinta mirando para arriba, colocar uno de los carretes en el eje del carrete de la izquierda. (Fig. 2) Asegurarse de que el carrete esté firmemente colocado en su lugar.
7. Pasar la cinta por la parte exterior de las guías metálicas. (Fig. 3)
8. Estirar cualquier parte de cinta floja girando con la mano uno de los carretes.
9. Volver a poner la tapa de la impresora.
10. Volver a poner el rollo de papel.

Tapa de la impresora

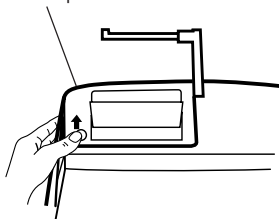

Fig. 1

Cinta entintada

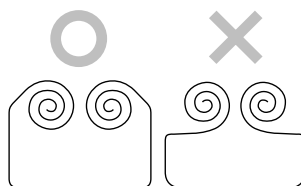

Fig. 2

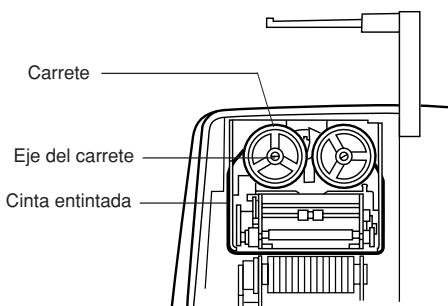

Fig. 3

CAMBIO DEL ROLLO DEL PAPEL

1. Levantar el sujetador del papel. (Fig. 1)
2. Doblar la punta del rollo de papel de 3 a 5 cm (no la doble nunca de forma oblicua). (Fig. 2)
3. Introducir el rollo de papel desde el lado izquierdo del sujetador del papel y asegurarse de que el rollo de papel esté puesto en la dirección correcta (con el avance del papel desde el fondo) tal como muestra la figura. (Fig. 3)
4. Introducir la punta doblada en la abertura directamente por detrás del mecanismo de impresión. (Fig. 4)
5. Apretar la tecla de avance del papel haciendo avanzar el papel por debajo del borde del cortapapel. (Fig. 5)

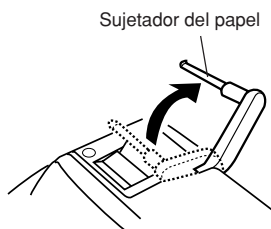

Fig. 1

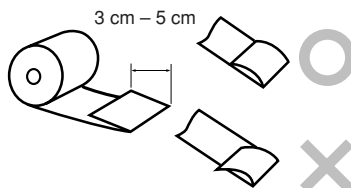

Fig. 2

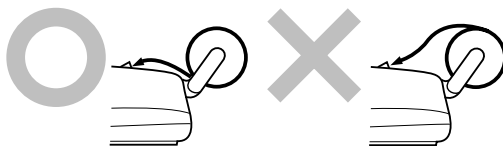

Fig. 3

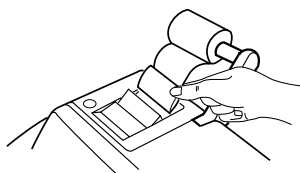

Fig. 4

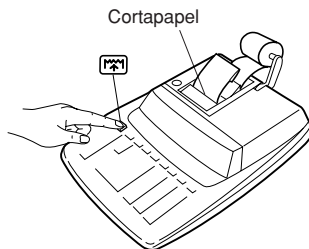

Fig. 5

NO TIRE DEL PAPEL HACIA ATRAS PORQUE SE PUEDE ESTROPEAR EL MECANISMO IMPRESOR.

ERRORES

Existen diversos casos en los que ocurre un exceso de capacidad o una condición de error. Al producirse esto, aparecerá el símbolo de error “E” quedando electrónicamente bloqueadas todas las teclas. Los contenidos de la memoria, en el momento del error, quedan retenidos.

Si, al ocurrir el error, se visualiza el símbolo “0•E”, se deberá usar $\boxed{*}$ para borrar la calculadora. Si se visualiza el símbolo “E” con cualquier número (excepto el cero), se puede borrar el error con \boxed{CE} o $\boxed{\rightarrow}$ pudiéndose continuar el cálculo.

Condiciones de error:

1. Entrada de más de 10 cifras o de 9 decimales. (VX-1652H)
Entrada de más de 12 cifras o de 11 decimales. (VX-2652H)
Este error puede borrarse con \boxed{CE} o $\boxed{\rightarrow}$.
2. Cuando la parte entera de un resultado excede las 10 cifras. (VX-1652H)
Cuando la parte entera de un resultado excede las 12 cifras. (VX-2652H)
3. Cuando la parte entera de los contenidos de la memoria supera los 10 dígitos. (VX-1652H)
(Ej. $\boxed{*M}$ 9999999999 $\boxed{M+}$ 1 $\boxed{M+}$)
Cuando la parte entera de los contenidos de la memoria supera los 12 dígitos. (VX-2652H)
(Ej. $\boxed{*M}$ 999999999999 $\boxed{M+}$ 1 $\boxed{M+}$)
4. Cuando se divide un número cualquiera por un divisor de cero. (Ej. 5 $\boxed{\div}$ 0 $\boxed{\frac{\square}{\square}}$)

ESPECIFICACIONES TECNICAS

Capacidad de cálculo:	10 cifras (VX-1652H) 12 cifras (VX-2652H)
Fuente de alimentación:	CA: 120V, 60Hz
Cálculos:	Las cuatro operaciones aritméticas, multiplicaciones y divisiones por constante, cálculos de potencia, cálculos de recargos/descuentos, repetición de sumas y restas, cálculos recíprocos, cálculos con memoria, cálculos de cuenta de artículos, cálculos de aumento, impresión de no suma, cálculos de total global, etc.

SECCION DE LA IMPRESORA

Impresora:	Impresora mecánica
Velocidad de impresión:	Aprox. 4,3 líneas/seg.
Papel de impresión:	57 mm ~ 58 mm de ancho, 80 mm de diámetro (máx.)
Temperatura:	0°C ~ 40°C
Potencia:	126 mA
Dimensiones:	250 mm (An.) × 345 mm (Pr.) × 78 mm (Al.)
Peso:	Aprox. 2,0 kg
Accesorios:	1 rollo de papel, 1 cinta entintada y manual de manejo

CALCULATION EXAMPLES EJEMPLOS DE CALCULOS

1. Set the decimal selector as specified in each example.
The rounding selector should be in the "5/4" position unless otherwise specified.
 2. The grand total mode selector and the constant/add mode selector should be in the "•" position (off position) unless otherwise specified.
 3. The print/item count mode selector should be in the "P" position unless otherwise specified.
 4. If an error is made while entering a number, press **CE** or **→** and enter the correct number.
 5. Negative values are printed with "-" symbol in red.
-
1. Colocar el selector decimal según se especifique en cada ejemplo.
El selector de redondeo debe estar en la posición "5/4" salvo que se especifique lo contrario.
 2. El selector de modo de total global y selector del modo de constante/suma debe estar en la posición "•" (posición de desconexión) salvo que se especifique lo contrario.
 3. El selector del modo de impresión/modo para contar artículos debe estar en la posición "P" salvo que se especifique lo contrario.
 4. Si se hace un error al ingresar un número, apretar **CE** ou **→** e ingresar el número correcto.
 5. Los valores negativos se imprimen con el símbolo "-" en rojo.

Note: All totals and sub-totals may be used for further calculations. **RE-ENTER** the number into the calculator by using the **FUNCTION** key and continue the problem.

Nota: Se pueden usar todos los totales y los totales parciales para cálculos posteriores. **VOLVER A INGRESAR** el número en la calculadora usando una tecla de **FUNCION** y continuar efectuando la operación.

EXAMPLE: EJEMPLO:

$$(123 + 456) \times 2 =$$

Selector Selector	Operation Operación	Print Impresión	Note Nota
F 6 4 3 2 1 0 	123 $\left[\begin{smallmatrix} + \\ - \end{smallmatrix} \right]$	123·00 +	* { Re-entry of total Reingreso del total
	456 $\left[\begin{smallmatrix} + \\ - \end{smallmatrix} \right]$	456·00 +	
	$\left[* \right]$	579·00 *	
	$\left[\times \right]$	* 579·00 ×	
	2 $\left[\begin{smallmatrix} + \\ - \end{smallmatrix} \right]$	2· =	
		1·158·00 *	

REPEAT ADDITION AND SUBTRACTION / REPETICION DE SUMAS Y RESTAS

$$123 + 123 + 123 + 456 - 100 - 100 =$$

Selector Selector (1)	Operation Operación (2)	Display Exhibición (3)	Print Impresión (4)
F 6 4 3 2 1 0 	123 $\left[\begin{smallmatrix} + \\ - \end{smallmatrix} \right]$	123.	123· +
	$\left[\begin{smallmatrix} + \\ - \end{smallmatrix} \right]$	246.	123· +
	$\left[\begin{smallmatrix} + \\ - \end{smallmatrix} \right]$	369.	123· +
	456 $\left[\begin{smallmatrix} + \\ - \end{smallmatrix} \right]$	825.	456· +
	100 $\left[\begin{smallmatrix} - \\ = \end{smallmatrix} \right]$	725.	100· -
	$\left[\begin{smallmatrix} - \\ = \end{smallmatrix} \right]$	625.	100· -
	$\left[* \right]$	625.	625· *

ADDITION AND SUBTRACTION WITH ADD MODE / SUMA Y RESTA CON MODO DE SUMA

$$12.45 + 16.24 + 19.35 - 5.21 =$$

(1)	(2) *1	(3)	(4)
F 6 4 3 2 1 0 	1245 $\boxed{+}$	12.45	12.45 +
	1624 $\boxed{+}$	28.69	16.24 +
K · A 	1935 $\boxed{+}$	48.04	19.35 +
	521 $\boxed{-}$	42.83	5.21 -
	$\boxed{*}$		42.83 *
		42.83	

*1 : $\boxed{\cdot}$ was not used in the entries.

*1 : La $\boxed{\cdot}$ no ha sido usada en los registros.

MIXED CALCULATIONS / CALCULOS MIXTOS

A. $(10 + 2) \times 5 =$

(1)	(2)	(3)	(4)
F 6 4 3 2 1 0 	10 $\boxed{+}$	10.	10. +
	2 $\boxed{+}$	12.	2. +
	$\boxed{\times}$		12. \diamond
		12.	12. \times
	5 $\boxed{+}$		5. =
		60.	60. *



B. $5 \times 2 + 12 =$

(1)	(2)	(3)	(4)
F 6 4 3 2 1 0 	5 $\boxed{\times}$	5.	5. \times
	2 $\boxed{+}$		2. =
			10. *
	$\boxed{+}$	10.	10. +
	12 $\boxed{+}$	22.	12. +
	$\boxed{*}$		22. *
		22.	

CONSTANT / CONSTANTES



A. $62.35 \times 11.11 = \textcircled{1}$

$62.35 \times 22.22 = \textcircled{2}$

(1)	(2)	(3)	(4)
	62.35 \times 11.11 \pm	62.35	$62.35 \times$ $11.11 = K$ $692.71 *$ $\textcircled{1}$
	22.22 \pm	692.71	$22.22 = K$ $1.385.42 *$ $\textcircled{2}$
		1,385.42	



B. $11.11 \div 77.77 = \textcircled{1}$

$22.22 \div 77.77 = \textcircled{2}$





(1)	(2)	(3)	(4)
	11.11 \div 77.77 \pm	11.11	$11.11 \div$ $77.77 = K$ $0.143 *$ $\textcircled{1}$
	22.22 \pm	0.143	$22.22 = K$ $0.286 *$ $\textcircled{2}$
		0.286	

POWER / POTENCIA

A. $5.25^2 =$



(1)	(2)	(3)	(4)
	5.25 \times \pm	5.25	$5.25 \times$ $5.25 =$ $27.563 *$
		27.563	

B. $5^3 =$



(1)	(2)	(3)	(4)
F643210  K · A 	5 <input type="button" value="×"/> <input type="button" value="±"/> <input type="button" value="±"/>	5. 25. 125.	5 · × 5 · =K 25 · * 25 · =K 125 · *
F643210  K · A 	5 <input type="button" value="×"/> <input type="button" value="×"/> <input type="button" value="±"/>	5. 25. 125.	5 · × 5 · × 5 · = 125 · *

PERCENT / PORCENTAJES

A. $100 \times 25\% =$



(1)	(2)	(3)	(4)
F643210  K · A 	100 <input type="button" value="×"/> 25 <input type="button" value="%"/>	100. 25.00	100 · × 25 · % 25 · 00 *

B. $123 \div 1368 = (\%)$

(1)	(2)	(3)	(4)
F643210  K · A 	123 <input type="button" value="÷"/> 1368 <input type="button" value="%"/>	123. 8.99	123 · ÷ 1 · 368 · % 8 · 99 *

RECIPROCAL / RECIPROCOS

$$\frac{1}{7} =$$

(1)	(2)	(3)	(4)
$\uparrow 5/4 \downarrow$  F 6 4 3 2 1 0 	7 $\boxed{+}$ $\boxed{+}$ $\boxed{\pm}$	7. 1. 0.14285714285 (0.142857142)	7 $\cdot \div$ 7 $\cdot \div$ 7 $\cdot =$ 0-14285714285 * 0-142857142 * VX-1652H)

ADD-ON AND DISCOUNT / RECARGOS Y DESCUENTOS

A. 5% add-on to 100. / Un 5% de recargo sobre 100.

(1)	(2)	(3)	(4)
F 6 4 3 2 1 0 	100 $\boxed{\times}$ 5 \boxed{MU}	100. 105.00	100 $\cdot \times$ 5% 5-00 { Increased amount { Incremento 105-00 * { New amount { Nueva cantidad

B. 10% discount on 100. / Un 10% de descuento sobre 100.

(1)	(2)	(3)	(4)
F 6 4 3 2 1 0 	100 $\boxed{\times}$ 10 $\boxed{+/-}$ \boxed{MU}	100. 90.00	100 $\cdot \times$ - 10-% - 10-00 { Discount { Descuento 90-00 * { Net amount { Cantidad neta

MARKUP AND MARGIN / INCREMENTO PORCENTUAL Y MARGEN

Markup and Profit Margin are both ways of calculating percent profit.

- Profit margin is percent profit vs. selling price.
- Markup is percent profit vs. cost.
- Cost is the cost.
- Sell is the selling price.
- GP is the gross profit.
- Mkup is the percent profit based on cost.
- Mrgn is the percent profit based on selling price.

Tanto la función del incremento porcentual como la del margen de beneficio son formas de calcular el beneficio porcentual.

- El margen de beneficio es el beneficio porcentual con respecto al precio de venta.
- El incremento porcentual es el beneficio porcentual con respecto al coste.
- Cost es el coste.
- Sell es el precio de venta.
- GP es el beneficio bruto.
- Mkup es el beneficio porcentual basado en el coste.
- Mrgn es el beneficio porcentual basado en el precio de venta.

To find Para encontrar	Knowing Sabiendo	Operation Operación				
Mrgn	Sell, Cost	Cost	$\frac{-}{=}$	Sell	$\frac{\pm}{\pm}$	MU
Mkup	Sell, Cost	Sell	$\frac{\pm}{\pm}$	Cost	$\frac{-}{=}$	MU
Sell	Cost, Mrgn	Cost	$\frac{+}{+}$	Mrgn	MU	
Cost	Sell, Mrgn	Sell	$\frac{\times}{\times}$	Mrgn	$\frac{+/-}{+/-}$	MU
Sell	Cost, Mkup	Cost	$\frac{\times}{\times}$	Mkup	MU	
Cost	Sell, Mkup	Sell	$\frac{+}{+}$	Mkup	$\frac{+/-}{+/-}$	MU

Ex. / Ej.

Cost	Sell	GP	Mkup	Mrgn
\$200	\$250	\$50	25%	20%

(1)	(2)	(3)	(4)
F 6 4 3 2 1 0 	200 \div 20 \square MU	200. 50.00	200 \div Cost 20 \cdot %M Mrgn 250 \cdot 00 * Sell 50 \cdot 00 GP GP

PERCENT CHANGE / CAMBIO PORCENTUAL

- Calculate the dollar difference (a) and the percent change (b) between two yearly sales figures \$1,500 in one year and \$1,300 in the previous.
- Calcular la diferencia en dólares (a) y el cambio porcentual (b) entre dos cifras de ventas anuales, \$1.500 en un año y \$1.300 en el año anterior.

(1)	(2)	(3)	(4)
F 6 4 3 2 1 0 	1500 \pm 1300 $- =$ \square MU	1,500.00 200.00 15.38	1,500 \cdot 00 + 1,300 \cdot 00 - 200 \cdot 00 * (a) 15.38 %C (b)

PERCENT PRORATION / DISTRIBUCION PROPORCIONAL DE PORCENTAJE

- Calculate the percentage of each of the parts to the whole.
- Calcular el porcentaje de cada artículo.

Expenses Gastos	%
\$123	(a)
456	(b)
789	(c)
(D)	(d)

(1)	(2)	(3)	(4)
F 6 4 3 2 1 0 	*M ⁺²		
	123 ±	123.00	123.00 +
	456 ±	579.00	456.00 +
	789 ±	1,368.00	789.00 +
	123 MU		1,368.00 * (D)
			123 · F
			8.99 %P (a)
		8.99	
		8.99 ^M	8.99 +M
	456 M+		456 · F
	MU		33.33 %P (b)
		33.33 ^M	
		33.33 ^M	33.33 +M
	789 M+		789 · F
	MU		57.68 %P (c)
		57.68 ^M	
		57.68 ^M	57.68 +M
	M+		100.00 ◊M (d)
	◊M	100.00 ^M	
		100.00	100.00 *M
	*M		
		100.00	

*2 : Press ***M** to clear the memory before starting a memory calculation.

*2 : Apretar ***M** para cancelar la memoria antes de empezar a efectuar un cálculo con memoria.

ITEM COUNT CALCULATION / CALCULO DE CUENTA DE ARTICULOS

Bill No. N° de factura	Number of bills Cantidad de facturas	Amount Importe
1	1	\$100.55
2	1	\$200.00
3	1	\$200.00
4	1	\$400.55
5	1	\$500.65
Total Total	(a)	(b)

(1)	(2)	(3)	(4)
F 6 4 3 2 1 0 	<input type="checkbox"/> * 100.55 <input type="checkbox"/> ±	100.55	100.55 +
	200 <input type="checkbox"/> ±	300.55	200.00 +
	<input type="checkbox"/> ±	500.55	200.00 +
	400.55 <input type="checkbox"/> ±	901.10	400.55 +
OFF • P P-IC 	500.65 <input type="checkbox"/> ±	1,401.75	500.65 +
	<input type="checkbox"/> *		005 (a)
			1,401.75 * (b)
		1,401.75	

GRAND TOTAL / TOTAL GLOBAL

$$100 + 200 + 300 = \textcircled{1}$$

$$+) 300 + 400 + 500 = \textcircled{2}$$

$$+) 500 - 600 + 700 = \textcircled{3}$$

Grand total / Total global $\textcircled{4}$

(1)	(2)	(3)	(4)
F 6 4 3 2 1 0 	<input type="checkbox"/> GT <input type="checkbox"/> * 100 <input type="checkbox"/> ±	100.	100. +
	200 <input type="checkbox"/> ±	300.	200. +
	300 <input type="checkbox"/> ±	600.	300. +
	<input type="checkbox"/> *		600. * + $\textcircled{1}$
GT • 	300 <input type="checkbox"/> ±	600. 300.	300. +
	400 <input type="checkbox"/> ±	700.	400. +
	500 <input type="checkbox"/> ±	1,200.	500. +
OFF • P P-IC 	<input type="checkbox"/> *		1,200. * + $\textcircled{2}$
		1,200. 500.	500. +
	500 <input type="checkbox"/> ±	100.	600. -
	600 <input type="checkbox"/> ±	600.	700. +
	700 <input type="checkbox"/> ±		600. * + $\textcircled{3}$
	<input type="checkbox"/> *	600.	
	<input type="checkbox"/> GT		2,400. * G $\textcircled{4}$
		2,400.	

MEMORY / MEMORIA

A. $46 \times 78 = \textcircled{1}$

$+) 125 \div 5 = \textcircled{2}$

$-) 72 \times 8 = \textcircled{3}$

Total / Total $\textcircled{4}$

(1)	(2)	(3)	(4)
F 6 4 3 2 1 0 █	$\boxed{*M}^{*3}$		
	46 $\boxed{\times}$	46.	46. \times
	78 $\boxed{M+}$		78.=
		3,588. ^M	3:588. $+M$ $\textcircled{1}$
	125 $\boxed{\div}$	125. ^M	125. \div
	5 $\boxed{M+}$		5.=
		25. ^M	25. $+M$ $\textcircled{2}$
	72 $\boxed{\times}$	72. ^M	72. \times
	8 $\boxed{M-}$		8.=
		576. ^M	576. $-M$ $\textcircled{3}$
	$\boxed{\diamond M}$		3:037. $\diamond M$ $\textcircled{4}$
		3,037. ^M	

B. $(123 + 45) \times (456 - 89) =$

(1)	(2)	(3)	(4)
F 6 4 3 2 1 0 	*3		
	123	123. ^M	123· +M
	45	45. ^M	45· +M
GT • 	456	456. ^M	456· +
	89	367. ^M	89· -
			367· \diamond
		367. ^M	367· \times
		168. ^M	168· \diamond M
			168· =
		61,656. ^M	61·656· *

*3 : Press to clear the memory before starting a memory calculation.

*3 : Apretar para cancelar la memoria antes de empezar a efectuar un cálculo con memoria.

$$C. \frac{(874 + 557) \times (7 + 8)}{(1,746 + 876) \div (12 + 23)} =$$

(1)	(2)	(3)	(4)
F 6 4 3 2 1 0 [] [] [] [] [] []	*M *I *4		
	12 M+	12. ^M	12 · +M
	23 M+	23. ^M	23 · +M
	1746 ±	1,746. ^M	1,746 · +
	876 ±	2,622. ^M	876 · +
	+		2,622 · ◇
		2,622. ^M	2,622 · ÷
	*M		35 · *M
		35.	
	M+		35 =
		75. ^M	75 · +M
	874 +I	874. ^{MI}	874 · +I
	557 +I	557. ^{MI}	557 · +I
	7 ±	7. ^{MI}	7 · +
	8 ±	15. ^{MI}	8 · +
	×		15 · ◇
		15. ^{MI}	15 · ×
	◇I		1,431 · ◇I
		1,431. ^{MI}	
	+	21,465. ^{MI}	1,431 · ÷
	◇M		75 · ◇M
		75. ^{MI}	
	±		75 =
		286. ^{MI}	286 · *
	*M		75 · *M
		75. I	
	*I		1,431 · *I
		1,431.	

*4: Press ***M** then ***I** to clear the contents of the First and Second memories before starting the operation.

*4: Antes de iniciar la operación, apriete ***M** y luego ***I** para borrar el contenido de la primera y de la segunda memoria.

TAX RATE CALCULATIONS CALCULOS CON EL TIPO DE IMPUESTO

EXAMPLE 1: Set a 5% tax rate. Calculate the total amount for adding a 5% tax to \$800.

EJEMPLO 1: Fijar el tipo de impuesto al 5%. Calcular la cantidad total resultante de añadir el impuesto del 5% a \$800.

(1)	(2)	(3)	(4)
F 6 4 3 2 1 0 <input style="width: 100px; height: 15px;" type="text"/>	5 <input type="checkbox"/> STR <input type="checkbox"/> TAX+	5. 5.000	TX 5·000 %
	800 <input type="checkbox"/> TAX+	840.	800· 40· TX 840·

EXAMPLE 2: Calculate the total amount for adding a 5% tax to the sum of \$500 and \$460.

EJEMPLO 2: Calcular la cantidad total resultante de añadir el impuesto de 5% a la suma de \$500 y \$460.

(1)	(2)	(3)	(4)
F 6 4 3 2 1 0 <input style="width: 100px; height: 15px;" type="text"/>	500 <input type="checkbox"/> ± 460 <input type="checkbox"/> ± <input type="checkbox"/> TAX+	500. 960. 1,008.	500· + 460· + 960· * 48· TX 1·008·

EXAMPLE 3: Calculate the total amount for the sum of \$500 with tax already included and \$460 with 5% tax to be added.

EJEMPLO 3: Calcular la cantidad total resultante de sumar \$500 con el impuesto ya incluido y \$460 con el impuesto del 5% a añadir.

(1)	(2)	(3)	(4)
F 6 4 3 2 1 0 <input type="text"/>	500 $\frac{\pm}{\equiv}$	500.	500· +
	460 $\frac{\text{TAX}+}{\equiv}$		460·
			23· TX
			483·
		483.	
	$\frac{\pm}{\equiv}$ * $\frac{\pm}{\equiv}$		483· +
		983.	983· *

DISCOUNT RATE CALCULATION CALCULO CON EL TIPO DE DESCUENTO

EXAMPLE: Set an 8% discount rate. Calculate the final amount for an 8% discount on \$800.

EJEMPLO: Fijar el tipo de descuento al 8%. Calcular la cantidad que se obtiene al hacer un descuento del 8% a \$800.

(1)	(2)	(3)	(4)
F 6 4 3 2 1 0 <input style="width: 50px; height: 15px;" type="text"/>	8 <input type="checkbox"/> $\frac{+}{-}$ <input type="checkbox"/> STR <input type="checkbox"/> TAX+	8. - 8.000 -	TX 8.000 % -
		736.	800. - 64. TX 736.

For your convenience, Genuine Sharp Supplies, Accessories, and additional Sharp Products can be purchased from the Authorized Sharp Reseller where you purchased your product or on-line at:

www.sharpplace.com

MEMO / NOTAS

MEMO / NOTAS

SHARP

SHARP ELECTRONICS CORPORATION

Sharp Plaza, Mahwah, New Jersey 07430-2135

www.sharp-usa.com

SHARP CORPORATION

PRINTED IN CHINA / IMPRESO EN CHINA

02BT(TINSZ0517EHZZ)