

Features

- Acrylic
- Two 2 hp variable speed pumps with back-lit user control and remote control
- 4 kW heater (on separate electrical service)
- 8 Flexjets
- Waterfall
- 4 Riverjets
- 4 chromatherapy lights (H2 model only)
- Air aspiration "On/Off" feature
- UL listed
- Less all trim
- 75" (190.5 cm) x 45" (114.3 cm) x 25" (63.5 cm) (27-1/2" (69.9 cm) high with pillow)
- One large pillow and two small pillows

QUADRANGLE K-1365-H2 ALSO K-1365-H3

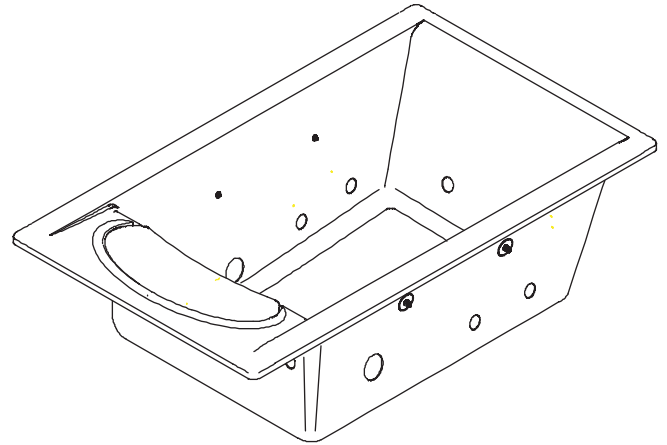

Codes/Standards Applicable

Specified model meets or exceeds the following:

- ANSI Z124.1
- ASME A112.19.7
- Underwriter's Laboratories (UL)

Colors/Finishes

- 0: White
- Other: Refer to Price Book for additional colors/finishes

Accessories:

- CP: Polished Chrome
- PB: Polished Brass
- Other: Refer to Price Book for additional colors/finishes

Specified Model

Model	Description	Colors/Finishes	
K-1365-H2	RiverBath Quadrangle with chromatherapy lights	<input type="checkbox"/> 0 White	<input type="checkbox"/> Other_____
K-1365-H3	RiverBath Quadrangle less chromatherapy lights	<input type="checkbox"/> 0 White	<input type="checkbox"/> Other_____

Recommended Accessories				
K-9398	Flexjet trim kit	<input type="checkbox"/> CP	<input type="checkbox"/> PB	<input type="checkbox"/> Other_____
K-9669	Grip rail kit	<input type="checkbox"/> CP	<input type="checkbox"/> PB	<input type="checkbox"/> Other_____

Recommended Accessory				
K-7167	Drain	<input type="checkbox"/> CP	<input type="checkbox"/> PB	<input type="checkbox"/> Other_____

Product Specification:

The RiverBath Quadrangle shall be 75" (190.5 cm) in length, 45" (114.3 cm) in width, and 25" (63.5 cm) in height (27-1/2"/69.9 cm in height with pillow). Bath shall be made of acrylic. Bath shall have 8 Flexjets, waterfall, 4 Riverjets, 4 chromatherapy lights (H2 model only), two 2 hp variable speed pumps, 4 kW heater, back-lit user control and remote control. Bath shall be UL listed. Bath shall be less all trim. Bath shall have air aspiration "On/Off" feature. Bath shall have one large pillow and two small pillows. Bath shall be Kohler Model K-1365-_____-_____.

RIVERBATH™

Technical Information

Fixture:*	basin area	top area	weight
Bathing well	46" (116.8 cm) x 34" (86.4 cm)	57" (144.8 cm) x 37" (94 cm)	215 lbs. (98 kg)
To overflow	water depth	capacity	
	20" (50.8 cm)	149 gal. (564 L)	

* Approximate measurements for comparison only.

Pump: (Qty. 2)	Hp	Voltage	Frequency	Amps
Variable speed	2 hp	240 V	50/60 Hz	18 A

Drop-in cut-out	73-1/2" (186.7 cm) x 43-1/2" (110.5 cm)		
Cut-out template	1000153-7		
Minimum access panel			
Pump/control	45" (114.3 cm) x 18" (45.7 cm)	required	

Required Electrical Service (2)

Two dedicated circuits required, each protected with Class A Ground-Fault Circuit-Interrupter (GFCI) or Earth-Leakage Circuit-Breaker (ELCB):	
Pump/control	220-240 V, 20 A, 50/60 Hz
Heater	220-240 V, 20 A, 50/60 Hz, 4 kW

Installation Notes

Install this product according to the installation guide.

Two separate 240 V electrical services required; one for the pump/control, and another for the heater.

Floor support under whirlpool must provide for a minimum of 2500 lbs. (1134 kg)

Hot water supply should be 70% of capacity or greater. Installations will vary.

Consult local and national codes for minimum air gap requirements if installing a spout on the faucet deck other than that supplied.

K-1365-H3

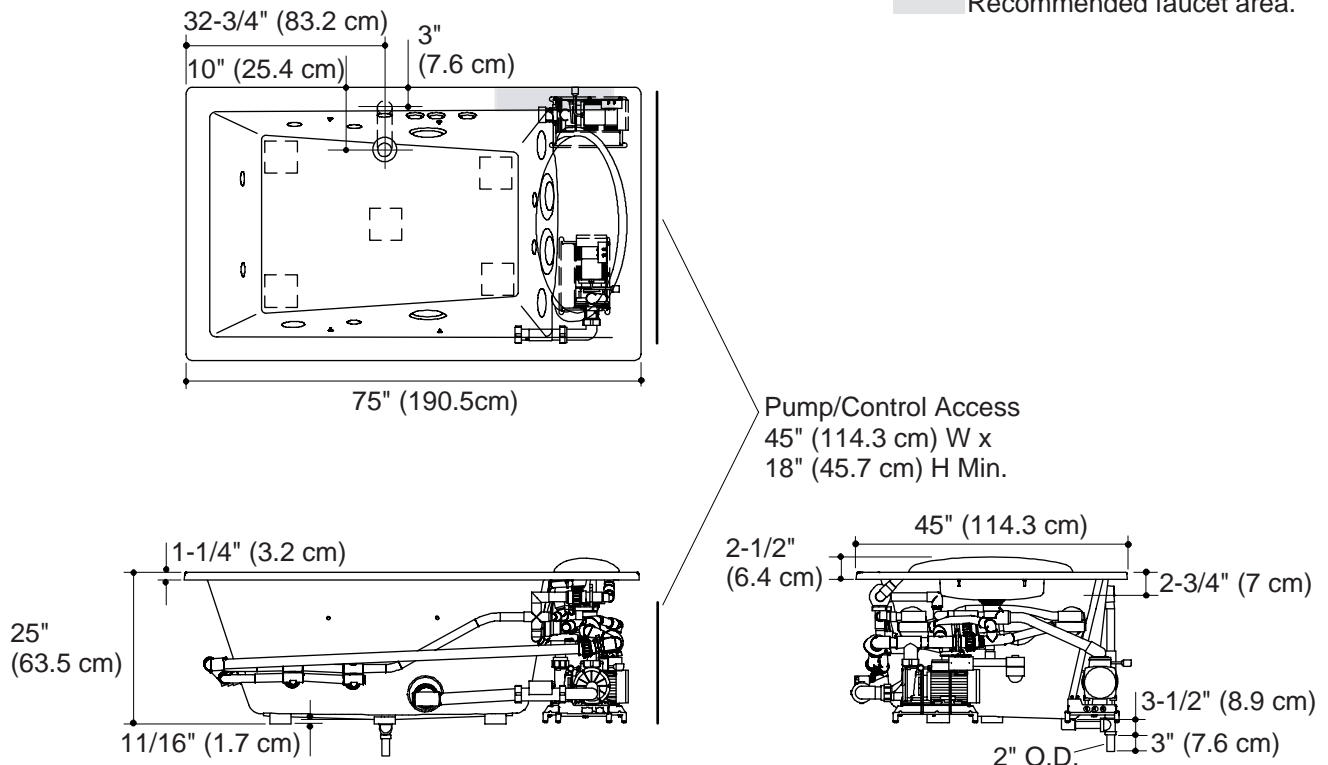

Product Diagram