

HONDA WATER PUMP **WH15X·WH20X**

OWNER'S MANUAL

Thank you for purchasing a Honda water pump.

This manual covers the operation and maintenance of WH15X and WH20X water pumps. All information in this publication is based on the latest product information available at the time of approval for printing.

Honda Motor Co., Ltd. reserves the right to make changes at any time without notice and without incurring any obligation.

The illustrations in this book are based on the WH20X unless otherwise noted.

No part of this publication may be reproduced without written permission.

This manual should be considered a permanent part of the pump and should remain with the pump when it is sold.

Pay special attention to statements preceded by the following words:

 **WARNING** Indicates a strong possibility of severe personal injury or loss of life if instructions are not followed.

CAUTION: Indicates a possibility of personal injury or equipment damage if instructions are not followed.

NOTE: Gives helpful information.

If a problem should arise, or if you have any questions about the pump, consult an authorized Honda dealer.

 **WARNING** Honda water pumps are designed to give safe and dependable service if operated according to instructions. Read and understand the Owner's Manual before operating the pump. Failure to do so could result in personal injury or equipment damage.

CONTENTS

| | |
|-----------------------------------|----|
| 1. SAFETY INSTRUCTIONS | 3 |
| 2. CAUTION LABEL LOCATION | 4 |
| 3. COMPONENT IDENTIFICATION | 5 |
| 4. PREPARATION | 6 |
| 5. STARTING THE ENGINE | 10 |
| 6. OPERATION | 12 |
| 7. STOPPING THE ENGINE | 13 |
| 8. MAINTENANCE | 14 |
| 9. TRANSPORTING/STORAGE | 19 |
| 10. TROUBLESHOOTING | 21 |
| 11. SPECIFICATIONS | 23 |
| 12. WARRANTY SERVICE | 24 |

1. SAFETY INSTRUCTIONS



To ensure safe operation---

- To prevent fire hazards and to provide adequate ventilation, keep the pump at least 3 ft away from buildings and other equipment during operation.
- Do not place flammable objects such as gasoline, matches, etc., close to the pump while it is running.
- Refuel in a well ventilated area with the pump stopped. Gasoline is flammable and explosive under certain conditions.
- Do not overfill the tank. There should be no fuel in the filler neck. Make sure that the filler cap is closed securely.
If any fuel is spilled, clean it up completely before starting the engine.
- Do not smoke or allow flames or sparks where the pump is refueled or where gasoline is stored.
- Exhaust contains poisonous carbon monoxide gas. Avoid inhalation of exhaust gases. Never run the pump in a closed garage or confined area.
- Operate the pump on a level surface. If the engine is tilted, fuel spillage may result.
- Nothing should be placed on the engine. It will cause fire hazards.
- Know how to stop the pump quickly and understand operation of all the controls. Never permit anyone to operate the pump without proper instructions.
- Keep children and pets away from the pump when it is in operation.
- Keep away from rotating parts while the pump is running.

2. CAUTION LABEL LOCATION

GASOLINE CAUTION LABEL

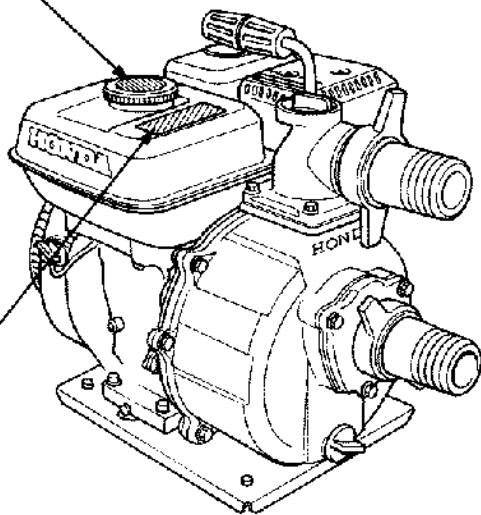

PUMP CAUTION LABEL

CAUTION! DO NOT RUN WITHOUT
PRIMING WATER. DRY OPERATION
WILL BURN THE SEAL.

VORSICHT! VOR DEM ANLAUFEN BEI
TESTUND LEERLAUF GEHÄUSE MIT
WASSER BEFÜLLEN. TROCKENAUF
ZERSTÖRT DIE DICHTUNGEN.

PRECAUCIÓN! NO HAGA FUNCIONAR
SIN CEBADO FUNCIONAMIENTO SECO
QUEMA EL SELLO.

PRÉCAUTION! NE FAITE PAS
FONCTIONNER SANS AMORSAGE.
FONCTIONNEMENT AU SEC BRÛLE LE
JOINT D'ÉTANCHEITE.

3. COMPONENT IDENTIFICATION

<WH20X>

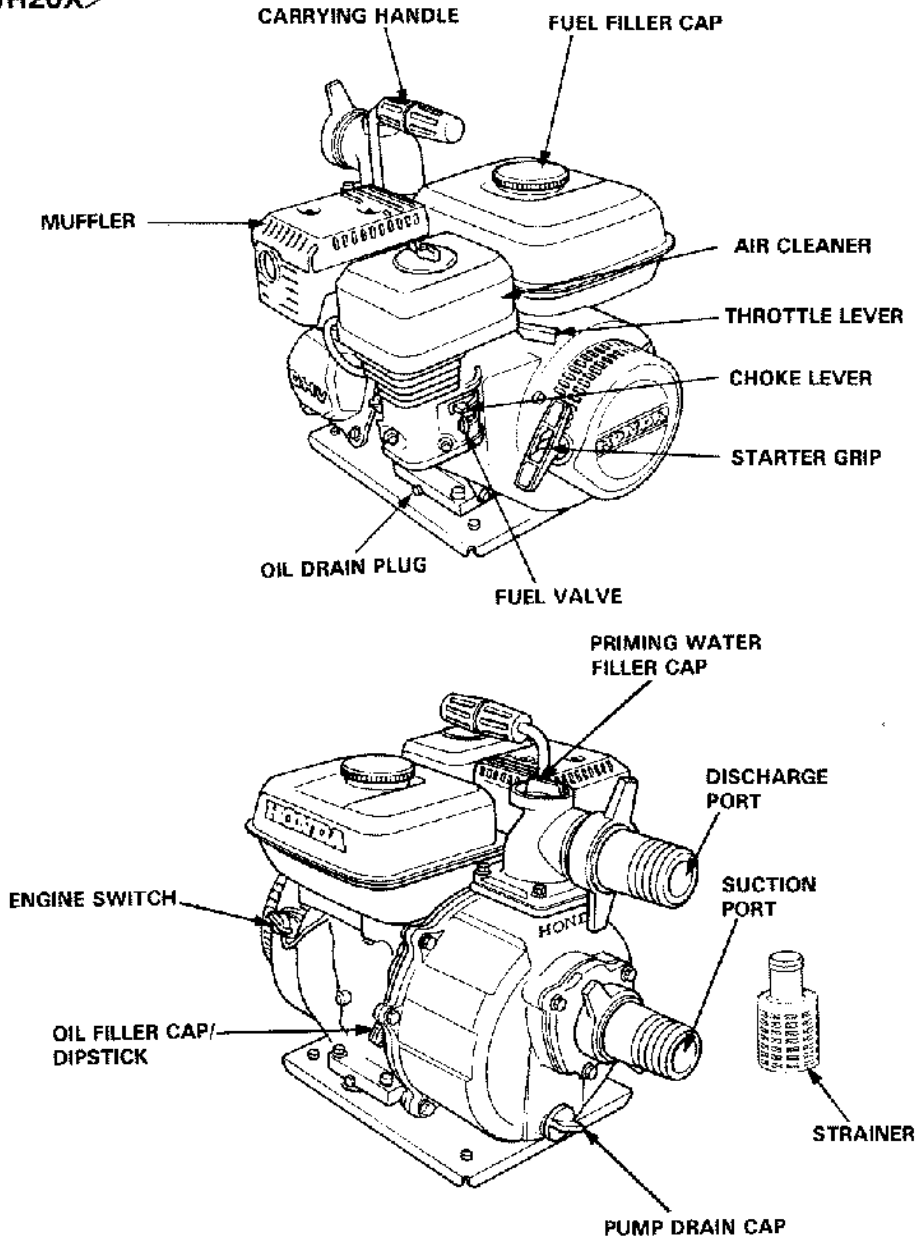

4. PREPARATION

1. Connect the suction hose.

Use a reinforced-wall or wire braided hose to prevent suction collapse. Since the pump's self-priming time is directly proportional to hose length, a short hose is recommended.

Secure the hose with the hose band.

CAUTION: Always install the strainer on the end of the suction hose before pumping. Gravel or debris sucked into the pump will cause serious impeller damage.

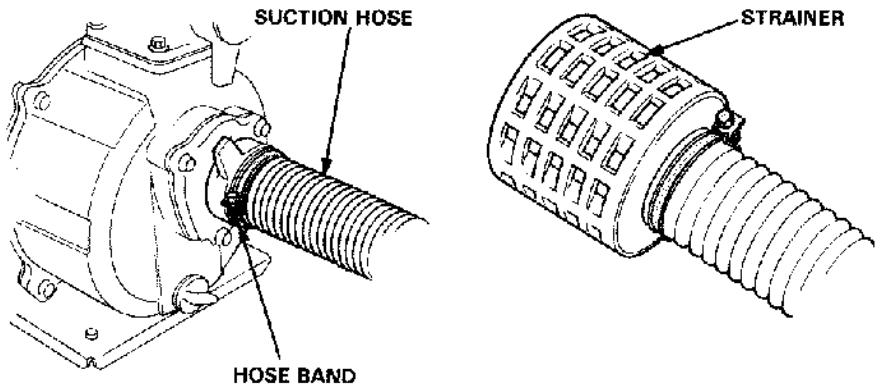

2. Connect the discharge hose.

When using a fabric hose, always use a hose band to prevent the hose from disconnecting under high pressure.

NOTE: A short, large-diameter hose will provide lower fluid friction and improve efficiency.

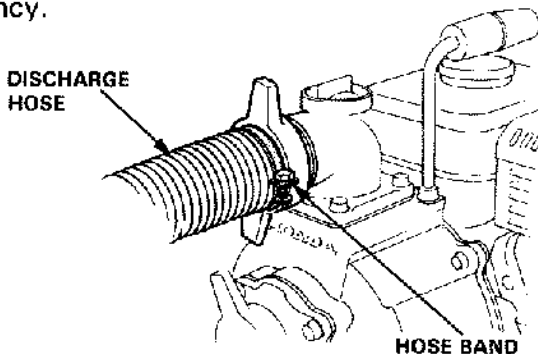

3. Check the engine oil level.

CAUTION:

- Engine oil is a major factor affecting engine performance and service life. Non-detergent or vegetable oils are not recommended.
- Be sure to check the engine on a level surface with the engine stopped.

Use Honda 4-stroke oil, or an equivalent high detergent, premium quality motor oil certified to meet or exceed U.S. automobile manufacturer's requirements for Service Classification SE or SF, (Motor oils classified SE or SF will show this designation on the container.)

SAE 10W-40 is recommended for general, all-temperature use.

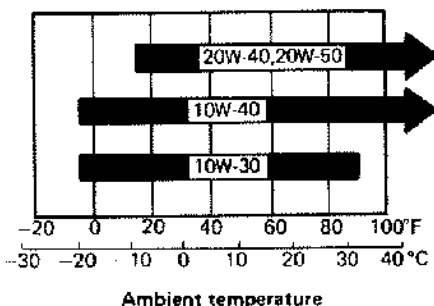

1. Remove the oil filler cap/dipstick and wipe it clean.
2. Insert the filler cap/dipstick into the oil filler neck, but do not screw it in.
3. If the level is low, fill to the top of the oil filler neck with recommended oil.

CAUTION: Running the engine with insufficient oil can cause serious engine damage.

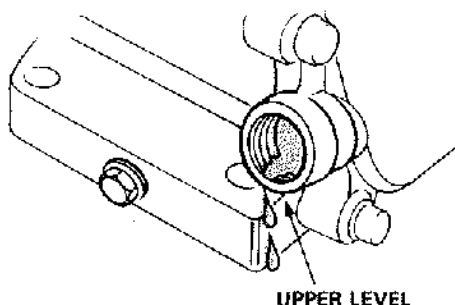
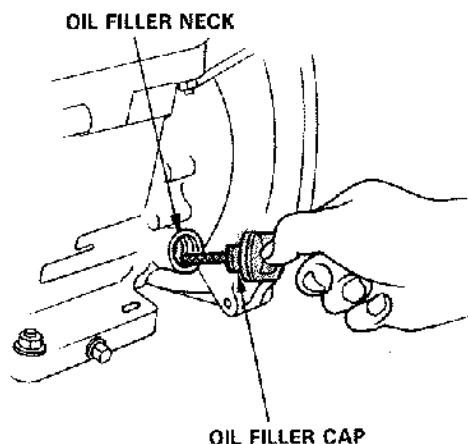

4. Check the fuel level

Use any regular grade automotive gasoline (unleaded gasoline is preferred) with a pump octane rating of 86 or higher.

Never use an oil/gasoline mixture or dirty gasoline. Avoid getting dirt, dust or water in the fuel tank.

CAUTION: Gasoline substitutes are not recommended; they may be harmful to fuel system components.

WARNING

- Gasoline is extremely flammable and explosive under certain conditions. Refuel in a well ventilated area with the engine stopped.
- Do not smoke or allow flames or sparks in the area where the engine is refueled or where gasoline is stored.
- Do not overfill the tank and make sure the filler cap is securely closed after refueling.
- Be careful not to spill fuel when refueling. Fuel vapor or spilled fuel may ignite. If any fuel is spilled, make sure the area is dry before starting the engine.

**Fuel tank capacity: WH15X.....2.5 lit. (0.66 US gal, 0.55 Imp gal)
WH20X.....3.6 lit. (0.95 US gal, 0.79 Imp gal)**

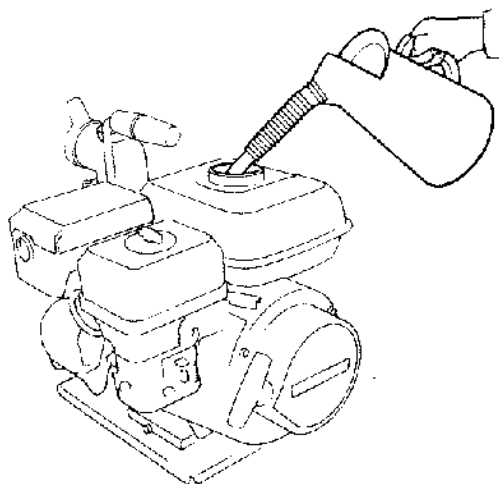

5. Check the air cleaner element.

Remove the wing nut, washer and air cleaner cover.
Check the element for dirt or obstruction.
Clean the element if necessary (see page 16).

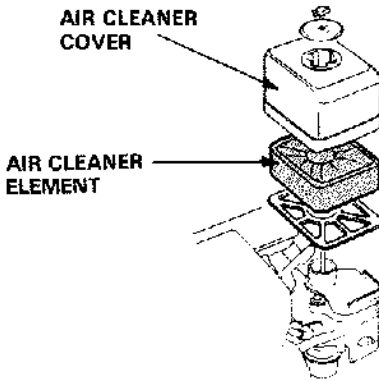

6. Check the priming water.

The pump chamber should be completely filled before operating.

CAUTION: Never attempt to operate the pump without priming water or the pump will overheat. Extended dry operation will destroy the pump seal. If the unit has been operated dry, stop the engine immediately and allow the pump to cool before adding priming water.

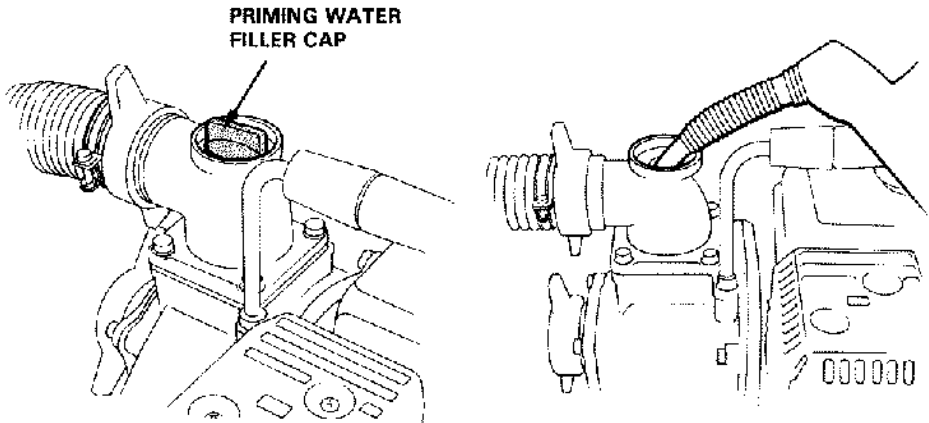

5. STARTING THE ENGINE

1. Turn the fuel valve ON.
2. Close the choke lever.

NOTE: Do not use the choke if the engine is warm or the ambient temperature is high.

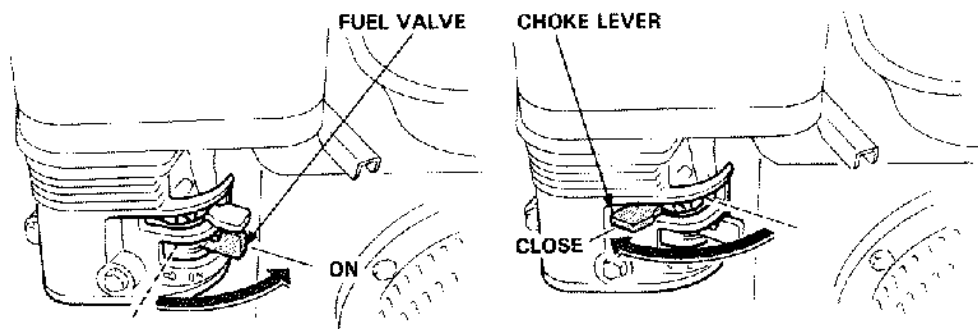

3. Turn the engine switch to the ON position.

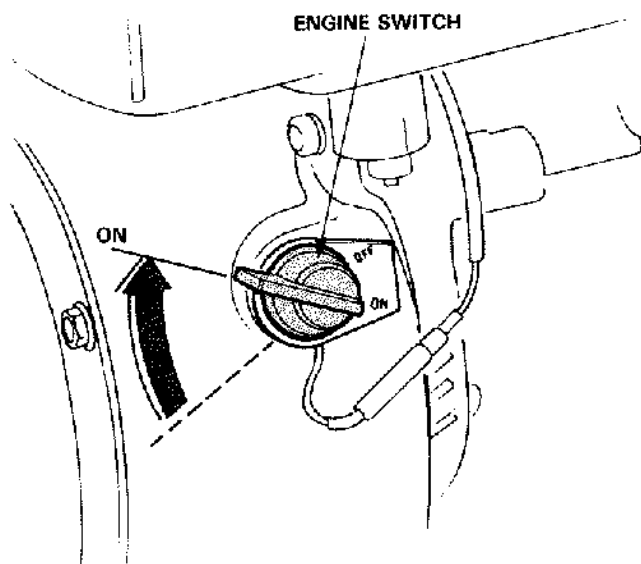

4. Move the throttle lever slightly to the left.

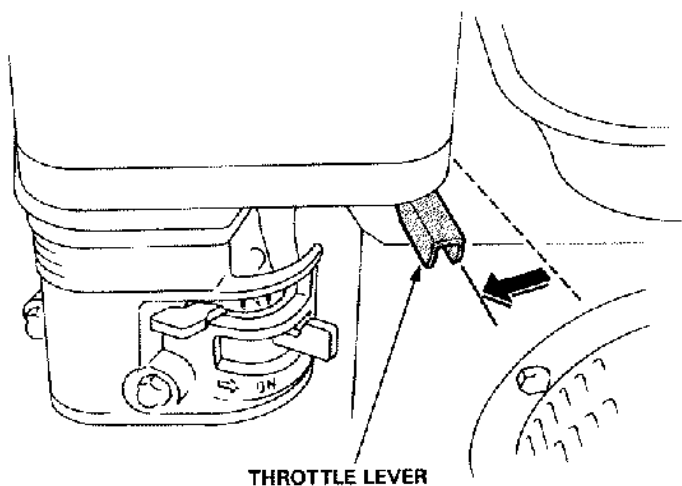

5. Pull the starter grip lightly until resistance is felt, then pull it briskly.

CAUTION: Do not allow the starter grip to snap back against the engine. Return it gently to prevent damage to the starter.

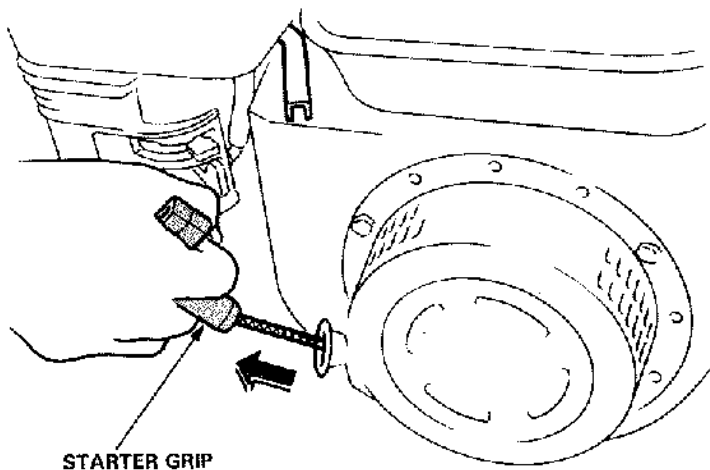

6. OPERATION

1. As the engine warms up, gradually open the choke.

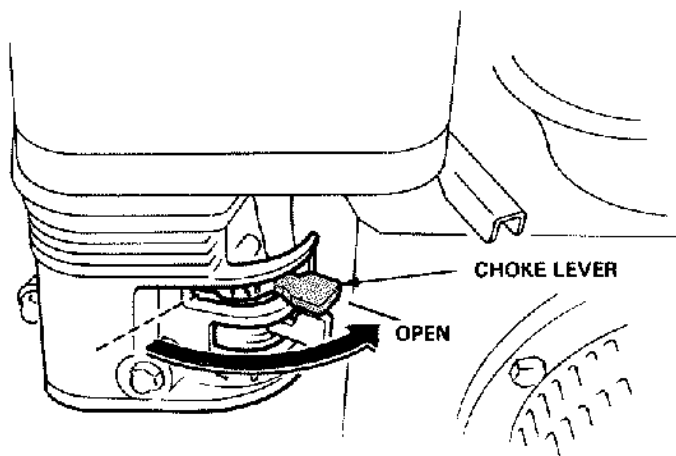

2. Set the throttle at the desired speed.

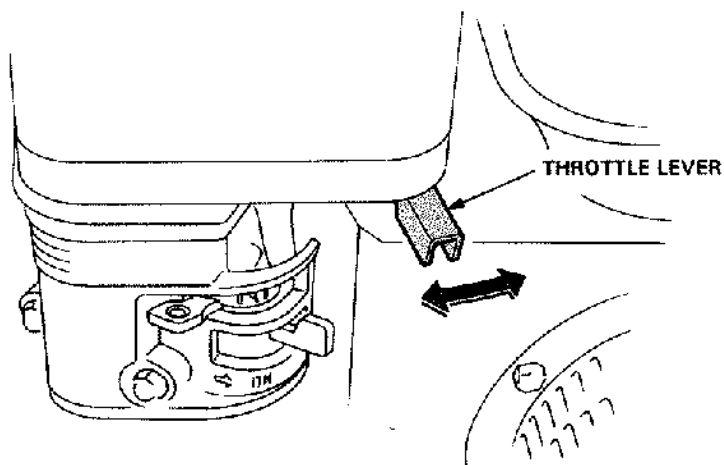

7. STOPPING THE ENGINE

1. Move the throttle lever fully to the right.
2. Turn the engine switch to the OFF position.

THROTTLE LEVER

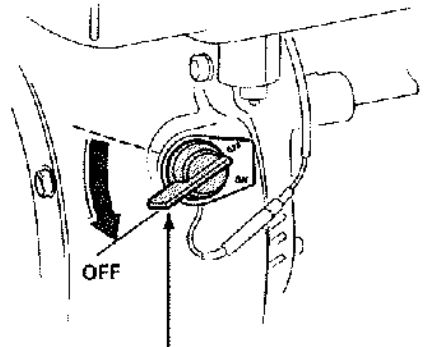
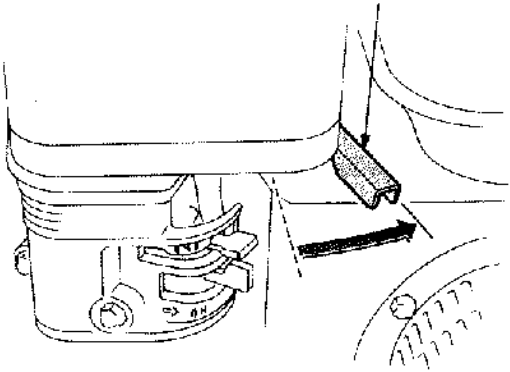

ENGINE SWITCH

3. Turn the fuel valve OFF.

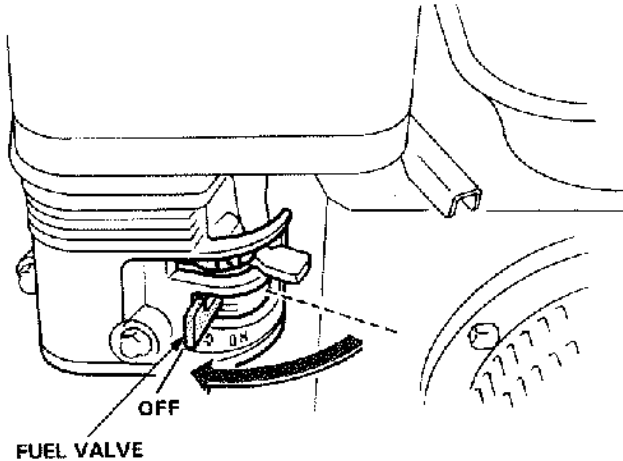

FUEL VALVE

NOTE: To stop the engine in an emergency, turn the engine switch to the OFF position.

8. MAINTENANCE

The purpose of the maintenance and adjustment schedule is to keep the engine in the best operating condition. Inspect or service as scheduled in the table below.

WARNING Shut off the engine before performing any maintenance. If the engine must be run, make sure the area is well ventilated. The exhaust contains poisonous carbon monoxide gas.

CAUTION:

- If the pump has been used with sea water, muddy water, etc., pump clean, fresh water through the pump immediately afterward to reduce corrosion and remove sediment.
- Use only genuine HONDA parts or their equivalent. The use of replacement parts which are not of equivalent quality may damage the engine.

Maintenance Schedule

| REGULAR SERVICE PERIOD performed at every indicated month or operating hour interval, whichever comes first. | | EACH USE | FIRST MONTH OR 20 HRS | EVERY 3 MONTHS OR 50 HRS | EVERY 6 MONTHS OR 100 HRS | EVERY YEAR OR 300 HRS |
|--|------------------------------|----------|-----------------------|--------------------------|---------------------------|-----------------------|
| ITEM | | | | | | |
| Engine oil | Check level | ○ | | | | |
| | Change | | ○ | | ○ | |
| Air cleaner | Check | ○ | | | | |
| | Clean | | | ○ (1) | | |
| Spark plug | Clean-Readjust | | | | ○ | |
| Valve clearance | Check-Readjust | | | | | ○ (2) |
| Fuel tank and strainer | Clean | | | | | ○ (2) |
| Impeller | Check | | | | | ○ (2) |
| Impeller clearance | Check | | | | | ○ (2) |
| Pump Inlet valve | Check | | | | | ○ (2) |
| Fuel line | Check (Replace if necessary) | | Every 3 years (2) | | | |

NOTE (1): Service more frequently when used in dusty areas.

(2): These items should be serviced by an authorized Honda dealer, unless the owner has the proper tools and is mechanically proficient. See the Honda Shop Manual.

1. Changing oil

Drain the oil while the engine is still warm to assure rapid and complete draining.

1. Remove the oil filler cap and the drain plug, then drain the oil.
2. Reinstall the drain plug and tighten securely.
3. Refill with the recommended oil (see page 7) to the specified level.

OIL CAPACITY: 0.6ℓ (0.63 US qt)

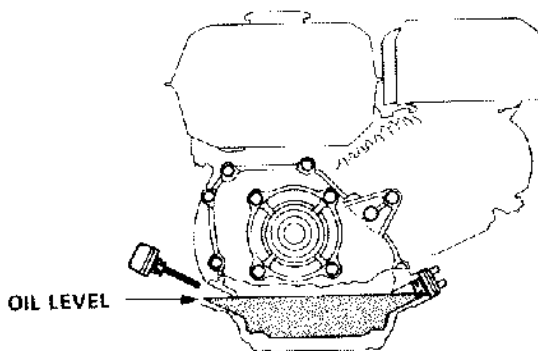
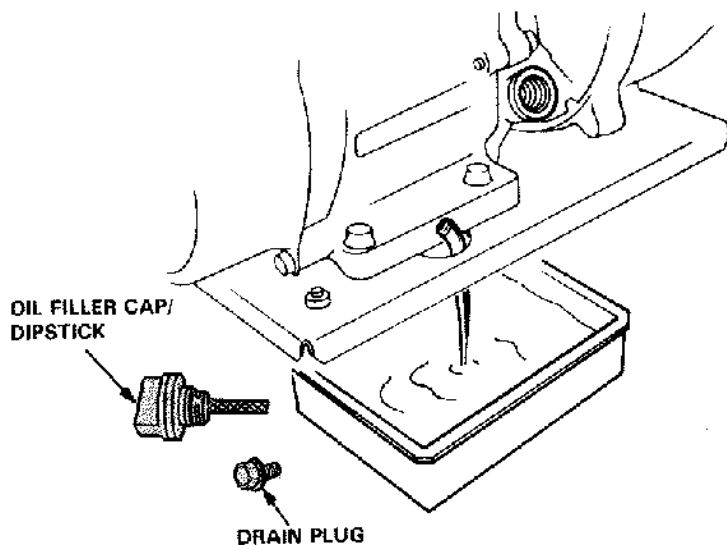

2. Air cleaner service

A dirty air cleaner will restrict air flow to the carburetor. To prevent carburetor malfunction, service the air cleaner regularly. Service more frequently when operating the pump in extremely dusty areas.

WARNING Never use gasoline or low flash point solvents for cleaning the air cleaner element. A fire or explosion could result.

CAUTION: Never run the pump without the air cleaner. Rapid engine wear will result.

1. Unscrew the wing nut, remove the air cleaner cover and remove the foam element.
2. Wash the element in a non-flammable or high flash point solvent and dry it thoroughly.
3. Soak the element in clean engine oil and squeeze out the excess oil.
4. Reinstall the air cleaner element and the cover.

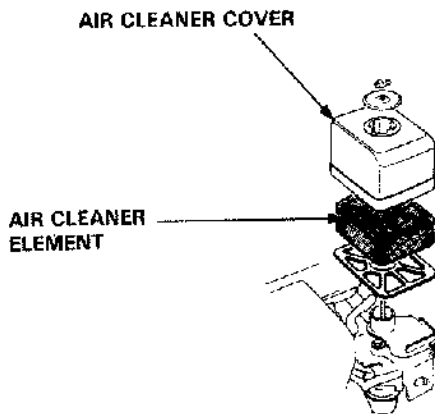

3. Spark plug service

Recommended spark plug: BPR6ES (NGK)
W20EPR-U (ND)

To ensure proper engine operation, the spark plug must be properly gapped and free of deposits.

1. Remove the spark plug.

WARNING If the engine has been running, the muffler will be very hot. Be careful not to touch the muffler.

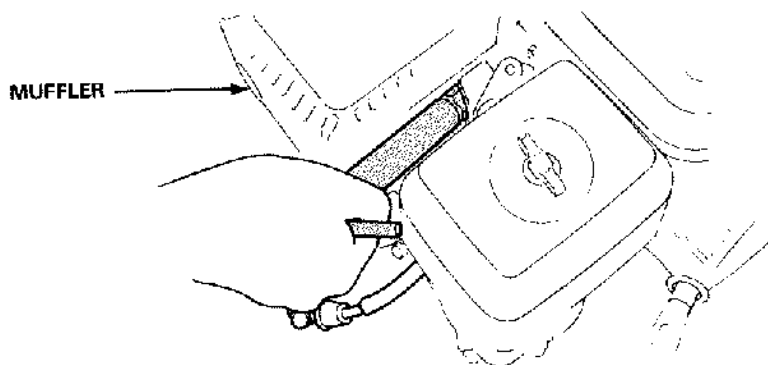

2. Visually inspect the spark plug. Discard it if the insulator is cracked or chipped. Clean the spark plug with a wire brush if it is to be reused.
3. Measure the plug gap with a feeler gauge. The gap should be 0.7–0.8 mm (0.028–0.031 in). Correct as necessary by bending the side electrode.

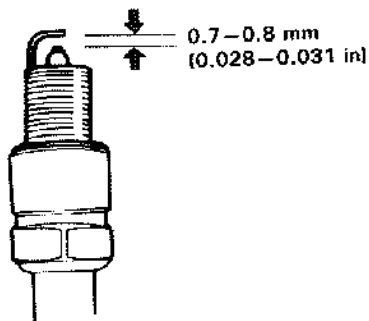

4. Thread the plug in by hand to prevent cross-threading.

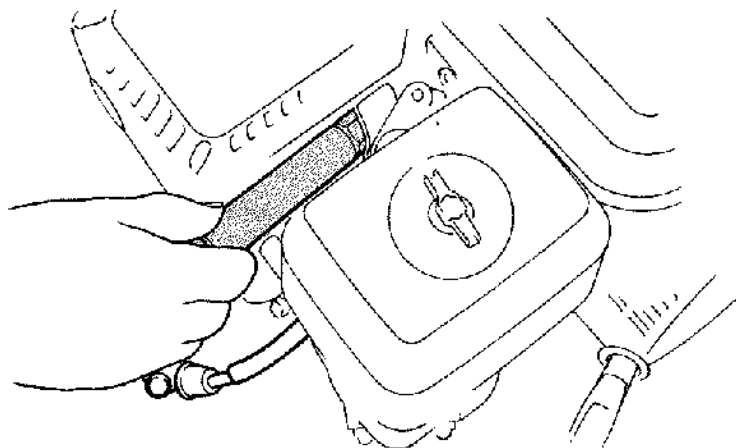

5. Tighten a new spark plug $1/2$ turn with the wrench to compress the washer. If you are reusing a plug, it should only take $1/8$ — $1/4$ turn after the plug seats.

CAUTION: The spark plug must be securely tightened. An improperly tightened plug can become very hot and damage the engine. Never use a spark plug with an improper heat range.

9. TRANSPORTING/STORAGE



WARNING When transporting the pump, turn the fuel valve OFF and keep the pump level to prevent fuel spillage. Fuel vapor or spilled fuel may ignite.

Before storing the pump for an extended period;

1. Be sure the storage area is free of excessive humidity and dust.
2. Clean the pump interior.....

Sediment will settle in the pump if it has been used in muddy or sandy water, or water containing heavy debris. Pump clean water through the pump before shutting down or impeller may be damaged when restarting. After flushing, remove the pump drain plug, and drain as much water as possible from the pump housing. After the pump is dry, spray Honda Rust Penetrant into the pump housing through the intake port, exhaust port, and drain hole, then install the drain plug.

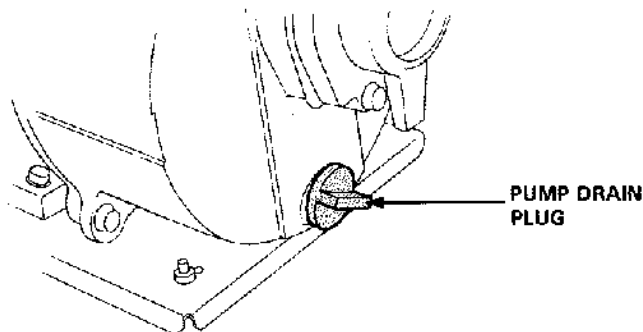

3. Drain the fuel.....

- a. With the fuel valve OFF, remove the carburetor drain screw and drain the carburetor. Drain the gasoline into a suitable container.
- b. Turn the fuel valve ON and drain the gasoline in the fuel tank into a suitable container.
- c. Reinstall the carburetor drain screw.

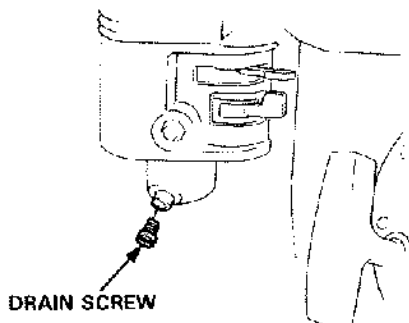

-
4. Pull the starter cord until resistance is felt. Continue pulling until the notch on the starter pulley aligns with the hole on the recoil starter (see illustration below). At this point, the intake and exhaust valves are closed, and this will help to protect the engine from internal corrosion.

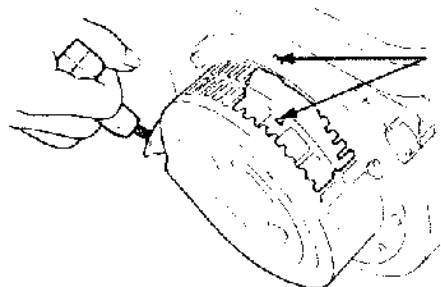

Align the mark on the starter pulley with the hole at the top of recoil starter.

5. Change engine oil.

10. TROUBLESHOOTING

When the engine will not start:

1. Is the engine switch ON?
2. Is there enough fuel?
3. Is the fuel valve on?
4. Is gasoline reaching the carburetor?

To check, remove the drain screw and turn the fuel valve on.

Fuel should flow out free.

WARNING If any fuel is spilled, make sure the area is dry before testing the spark plug or starting the engine. Fuel vapor or spilled fuel may ignite.

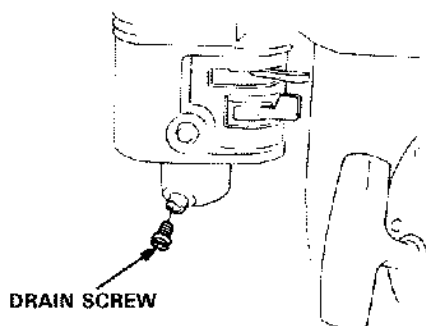

5. Is there a spark at the spark plug?

- a. Remove the spark plug cap. Clean any dirt from around the spark plug base, then remove the spark plug.
- b. Install the spark plug in the plug cap.
- c. Turn the engine switch on.
- d. Ground the side electrode to any engine ground, pull the recoil starter to see if sparks jump across the gap.
- e. If there are no sparks, replace the plug.
If OK, install the new plug and try to start the engine according to the instructions.

6. If the engine still does not start, take the pump to an authorized Honda water pump dealer.

When the pump does not pump water:

1. Is the pump fully primed?

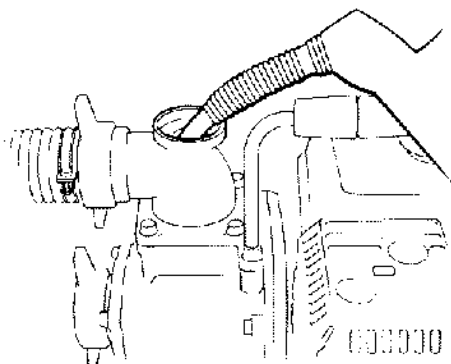

2. Is the strainer clogged?

3. Are the hose bands installed securely?

4. Are the hoses damaged?

5. Is the suction head too high?

6. If the pump still does not pump the water, take the pump to an authorized Honda water pump dealer.

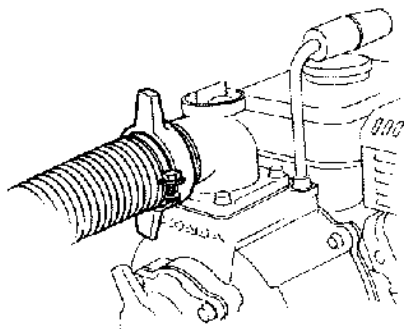
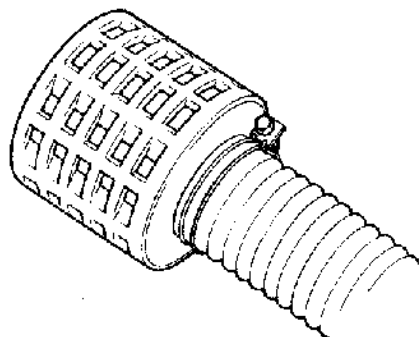

11. SPECIFICATIONS

| Model | WH15X | WH20X |
|-------|-------|-------|
|-------|-------|-------|

Dimensions and Weight

| | | |
|-------------------------|---|---|
| Length x Width x Height | 430 x 360 x 400 mm (16.9 x 14.2 x 15.7 in) | 435 x 375 x 400 mm (17.1 x 14.8 x 15.7 in) |
| Dry weight (mass) | 22 kg (48.5 lb) | 23.5 kg (51.8 lb) |

Engine

| Model | GX110 | GX140 |
|---------------------------------|---|---|
| Engine type | 4-stroke, over head valve, 1 cylinder | |
| Displacement {Bore x Stroke} | 107 cc (6.6 cu in) [57 x 42 mm (2.2 x 1.7 in)] | 144 cc (8.8 cu in) [64 x 45 mm (2.5 x 1.8 in)] |
| Max. output | 3.5 PS/3600 rpm | 5.0 PS/3600 rpm |
| Max. torque | 0.7 kg-m (5.2 ft-lb)/ 2,500 rpm | 1.0 kg-m (7.7 ft-lb)/ 2,500 rpm |
| Cooling system | Forced air | |
| Ignition system | Transistor magneto | |
| PTO shaft rotation | Counterclockwise | |

Pump

| | | |
|-------------------------|-------------------------|-------------------------|
| Suction port diameter | 38 mm (1.5 in) | 50 mm (2 in) |
| Discharge port diameter | 38 mm (1.5 in) | 50 mm (2 in) |
| Rated revolutions | 3,000 rpm | 3,850 rpm |
| Total head | 50 m (164 ft) | 50 m (164 ft) |
| Suction head | 8 m (27.9 ft) | 8 m (27.9 ft) |
| Capacity | 400ℓ (106 US gal)/min | 500ℓ (132 US gal)/min |
| Self-priming time | 40 sec at 5 m (16.4 ft) | 60 sec at 5 m (16.4 ft) |
| Continuous running time | 2h20min | 2h30min |

12. WARRANTY SERVICE

Owner Satisfaction

Your satisfaction and goodwill are important to your dealer and to us. All Honda warranty details are explained in the Distributor's Limited Warranty. Normally, any problems concerning the product will be handled by your dealer's service department. If you have a warranty problem that has not been handled to your satisfaction, we suggest you take the following action:

- Discuss your problem with a member of dealership management. Often complaints can be quickly resolved at that level. If the problem has already been reviewed with the Service Manager, contact the owner of the dealership or the General Manager.
- If your problem still has not been resolved to your satisfaction, contact the Customer Relations Department at the regional office of American Honda Motor Co., Inc. in your area. Regional office locations are shown on the following page. We will need the following information in order to assist you:
 - Your name, address, and telephone number
 - Product model and serial number
 - Date of purchase
 - Dealer name and address
 - Nature of the problem

After reviewing all the facts involved, you will be advised of what action can be taken. Please bear in mind that your problem will likely be resolved at the dealership, using the dealer's facilities, equipment, and personnel, so it is very important that your initial contact be with the dealer.

Your purchase of a Honda product is greatly appreciated by both the dealer and American Honda Motor Co., Inc. We want to assist you in every way possible to assure your complete satisfaction with your purchase.

Regional Office Locations

NORTHWEST REGIONAL OFFICE

(includes Alaska)
American Honda Motor Co., Inc.
Customer Relations Department
P.O. Box 30285
Portland, Oregon 97220
Telephone: (503) 255-1186

MIDWEST REGIONAL OFFICE
American Honda Motor Co., Inc.
Customer Relations Department
P.O. Box 22
Greendale, Wisconsin 53129
Telephone: (414) 421-9300

NORTHEAST REGIONAL OFFICE
American Honda Motor Co., Inc.
Customer Relations Department
P.O. Box 749
Moorestown, New Jersey 08057
Telephone: (609) 778-1100

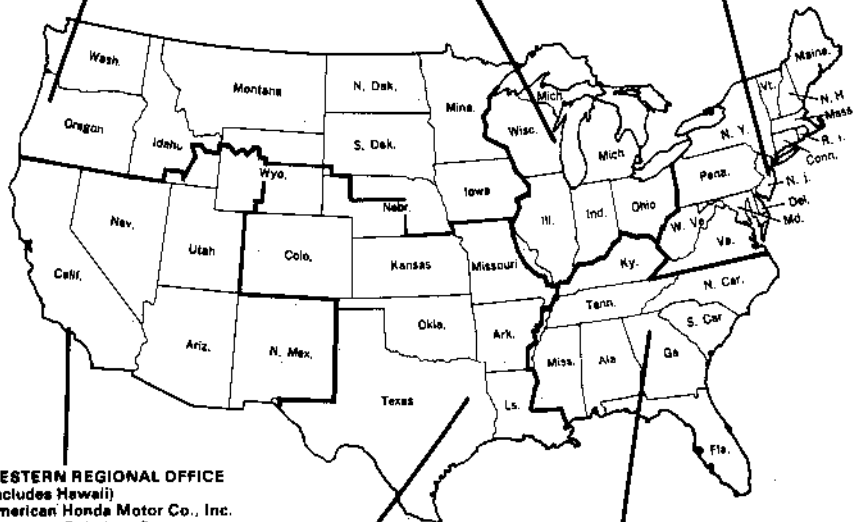

WESTERN REGIONAL OFFICE

(includes Hawaii)
American Honda Motor Co., Inc.
Customer Relations Department
P.O. Box 420
Gardens, California 90247
Telephone: (213) 604-2524

SOUTHWEST REGIONAL OFFICE

American Honda Motor Co., Inc.
Customer Relations Department
P.O. Box 5406
Irving, Texas 75062
Telephone: (214) 258-6883

SOUTHEAST REGIONAL OFFICE

(includes Puerto Rico)
American Honda Motor Co., Inc.
Customer Relations Department
6664 Jimmy Carter Boulevard
Norcross, Georgia 30071
Telephone: (404) 448-1992

MEMO

MEMO

MEMO



HONDA

HONDA MOTOR CO., LTD. TOKYO, JAPAN

31YB7000
00X31-YB7-0000

Ⓐ Ⓜ 15008412F
PRINTED IN JAPAN