

# Installation Instructions / Warranty

**hansgrohe**



**3-Jet Wallbar Set 06888XX0**  
**Wallbar 06890XX0**

**interaktiv**

**hansgrohe**

**retroaktiv**

**hansgrohe**

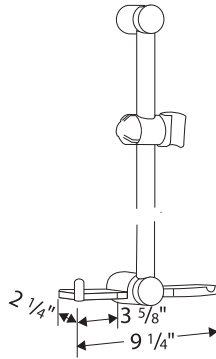
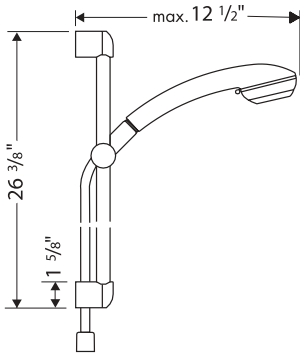

## Installer Notes

These installation instructions show that water will be furnished through an existing shower arm. This is not the only installation possible. A Hansgrohe 27454XX1 or equivalent wall supply may also be used.

The screws and anchors included with this set are suitable for use in a tile or other solid-surface wall. They are not suitable for use in an acrylic or fiberglass shower enclosure. Please contact the manufacturer of the enclosure regarding recommended mounting locations, reinforcement requirements, and recommended mounting hardware.

## Backflow Prevention

A backflow preventer (or vacuum breaker) is required by many local plumbing codes to protect your drinking water from back siphonage.

Hansgrohe recommends the use of external vacuum breaker 06510000 if backflow prevention is not provided by another device, such as a 27458XX1 wall outlet with integral vacuum breaker.

## Remove the old showerhead

- While holding the shower arm, remove the existing showerhead by turning counter-clockwise with an adjustable wrench.
- Thoroughly clean the threads on the shower arm with a wire brush.

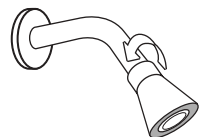

## Install the Wallbar

Tools Required (not included): a) adjustable wrench, b) drill with 1/4" (6.4 mm) bit suitable for the wall surface, c) Philips head screwdriver, d) silicon sealant, e) plumbers' thread tape (i.e. Teflon™ tape)

- Remove decorative screw covers from wall bar end pieces. Position bar so hand shower may be adjusted at a convenient height for intended users. Mark location of mounting holes. Put wall bar in a safe location. **CAUTION:** Do not install wall bar directly between shower arm and valve. A water line may be located there and may be damaged while drilling mounting holes.

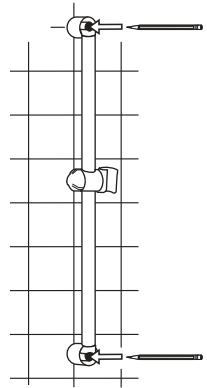

- Drill holes through shower wall. Install anchors. Seal wall around the anchors with silicon sealant.

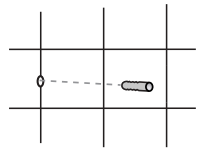
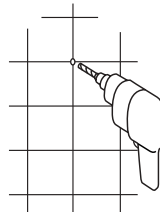

- Attach wall bar to wall using screws and metal washers provided.
- Reinstall decorative screw covers.

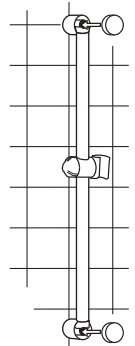

- Wrap the threads on the end of the shower arm with several layers of thread tape. Screw backflow preventer to shower arm. Wrap threads on backflow preventer (if using - not included) with thread tape. Remove protective plastic cap from long hose end connector to expose the two black rubber washers. Place a black rubber washer in short hose end connector. Screw it firmly to backflow preventer.
- Place the second black rubber washer in the long hose end connector. Screw hand shower into hose, taking care not to cross thread. Tighten hand tight only - using a wrench may damage decorative finish on hose end.
- Feed hose through hand shower holder. Lower hand shower until hose end is seated firmly in holder.
- Install soap dish.
- Turn on the water and check all connections for leaks.

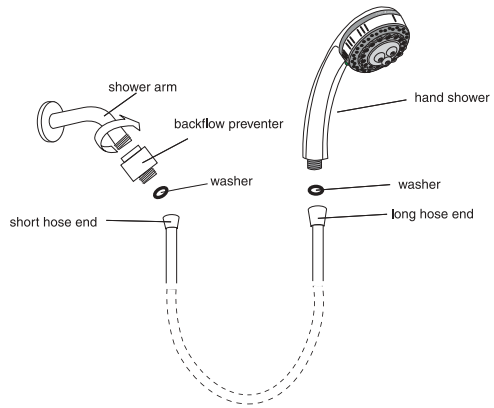

## Using the Interaktiv Wallbar

- To remove hand shower from holder, pull up on hand shower until hose end clears holder, then pull out.
- To change angle of hand shower holder, make sure hand shower is seated firmly in holder. Grasp top of hand shower. Using it as a lever, pull or push to desired angle.

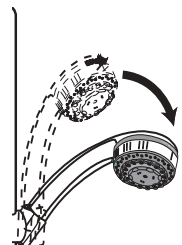

# Replacement Parts

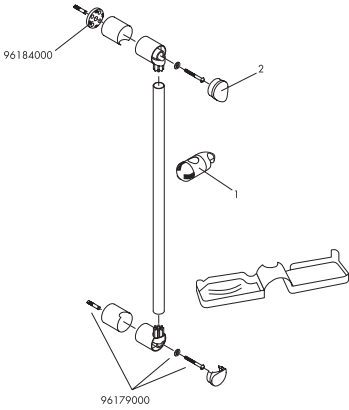

- |    |                  |                 |          |
|----|------------------|-----------------|----------|
| 1. | slider           | chrome          | 30485498 |
|    |                  | polished brass  | 30485489 |
|    |                  | brushed nickel  | 30485488 |
|    |                  | polished nickel | 30485483 |
| 2. | end cap          | chrome          | 88534000 |
|    |                  | polished brass  | 88534930 |
|    |                  | brushed nickel  | 88534820 |
|    |                  | polished nickel | 88534830 |
| 3. | double soap dish |                 | 69007000 |

## Cleaning Recommendation for Hansgrohe Products

Modern faucetry and shower products utilize a combination of materials to comply with the needs of the market with regard to design and functionality.

To avoid damage, it is necessary to use some caution when cleaning. Damage caused by improper treatment is not covered under the Hansgrohe warranty.

### Cleaning Materials for Faucets and Showers

- To remove lime scale, use only products made specifically for that purpose. Always follow the manufacturer's instructions when using.
- Do not use cleaners that contain hydrochloric, formic, acetic, or phosphoric acids, as these will cause considerable damage to finishes and to plastic components.
- Never mix cleaning materials.
- Never use cleaners containing abrasives. Do not use abrasive cleaning cloths, pads, or sponges.

### Cleaning Procedures

- Clean your faucets and shower products as and when required. Regular cleaning will prevent scale buildup and water spotting.
- Follow the label instructions. Do not allow any cleaner to remain on the product for longer than necessary.
- When using spray cleaners, spray first onto a sponge or cloth – do not spray directly onto the product.
- After cleaning, rinse thoroughly with clear water to remove any cleaner residue.

### Important

- Soap and shampoo residue can also cause damage to the product. Rinse well with clean water after use.
- If the surface is already damaged, harsh cleaning materials will cause further damage.

## Limited Lifetime Consumer Warranty

This product has been manufactured and tested to the highest quality standards by Hansgrohe, Inc. ("Hansgrohe"). This warranty is limited to Hansgrohe products which are purchased by a consumer in the United States after March 1, 1996, and installed in either the United States or Canada.

### WHO IS COVERED BY THE WARRANTY

This warranty extends to the original consumer purchaser only.

### WHAT IS COVERED BY THE WARRANTY

This warranty covers only your Hansgrohe manufactured product. Hansgrohe warrants this product against defects in material or workmanship as follows: Hansgrohe will repair at no charge for parts only or, at its option, replace any product or part of the product which proves defective because of improper workmanship and/or material, under normal installation, use, service and maintenance. If Hansgrohe is unable to provide a replacement and repair is not practical or cannot be timely made, Hansgrohe may elect to refund the purchase price in exchange for the return of the product.

### LENGTH OF WARRANTY

Replacement or repaired parts of products will be covered for the term of this warranty as stated in the following two sentences. If you are a consumer who purchased the product for use primarily for personal, family, or household purposes, this warranty extends for as long as you own the product and the home in which the product is installed. If you purchased the product for use primarily for any other purpose, including, without limitation, a commercial purpose, this warranty extends only (i) for 1 year, with respect to Interaktiv and Retroaktiv products, and (ii) for 5 years, with respect to AXOR, ShowerPower and Pharo products.

**THIS WARRANTY DOES NOT COVER, AND HANSGROHE WILL NOT PAY FOR:**

- A. Conditions, malfunctions or damage not resulting from defects in material or workmanship.
- B. Conditions, malfunctions or damage resulting from (1) improper installation, improper maintenance, misuse, abuse, negligence, accident or alteration, or (2) the use of abrasive or caustic cleaning agents or “no rinse” cleaning products, or the use of the product in any manner contrary to the product instructions.
- C. Labor or other expenses for the disconnection or return of the product for warranty service, or for installation or reinstallation of the product.
- D. Accessories or related products not manufactured by Hansgrohe.

**TO OBTAIN WARRANTY SERVICE**

Contact your Hansgrohe retailer, or write to Technical Service at:

Hansgrohe Inc.  
1492 Bluegrass Lakes Parkway  
Alpharetta GA 30004

Or, call Hansgrohe toll-free at (800) 334-0455.

In requesting warranty service, you will need to provide

- 1. The sales receipt or other evidence of the date and place of purchase.
- 2. A description of the problem.
- 3. Delivery of the product or the defective part, postage prepaid and carefully packed and insured, to Hansgrohe Inc. 1492 Bluegrass Lakes Parkway, Alpharetta, Georgia 30004, Attention: Technical Service, if required by Hansgrohe.

When warranty service is completed, any repaired or replacement product or part will be returned to you postage prepaid.

**EXCLUSIONS AND LIMITATIONS**

**REPAIR OR REPLACEMENT (OR, IN LIMITED CIRCUMSTANCES, REFUND OF THE PURCHASE PRICE) AS PROVIDED UNDER THIS WARRANTY IS THE EXCLUSIVE REMEDY OF THE PURCHASER. HANSGROHE NEITHER ASSUMES NOR AUTHORIZES ANY PERSON TO CREATE FOR IT ANY OBLIGATION OR LIABILITY IN CONNECTION WITH THIS PRODUCT.**

**HANSGROHE SHALL NOT BE LIABLE TO PURCHASER OR ANY PERSON FOR ANY INCIDENTAL, SPECIAL, OR CONSEQUENTIAL DAMAGES, ARISING OUT OF BREACH OF THIS WARRANTY OR ANY IMPLIED WARRANTY (INCLUDING MERCHANTABILITY).**

Some States do not allow the exclusion or limitation of incidental or consequential damages, so the above limitation or exclusion may not apply to you.

This warranty gives you specific legal rights, and you may have other rights which vary from State to State.

You may be required by law to give us a reasonable opportunity to correct or cure any failure to comply before you can bring any action in court against us under the Magnuson-Moss Warranty Act.

**PRODUCT INSTRUCTIONS AND QUESTIONS**

Upon purchase or prior to installation, please carefully inspect your Hansgrohe product for any damage or visible defect. Prior to installing, always carefully study the enclosed instructions on the proper installation and the care and maintenance of the product. If you have questions at any time about the use, installation, or performance of your Hansgrohe product, or this warranty, please call or write to us at the toll-free number and address printed above.

