



GE Appliances

Water Filtration System

**Owner's Manual
and Installation**

GNUL30B
GNUT05B
GXEM01B

Faucet & Base

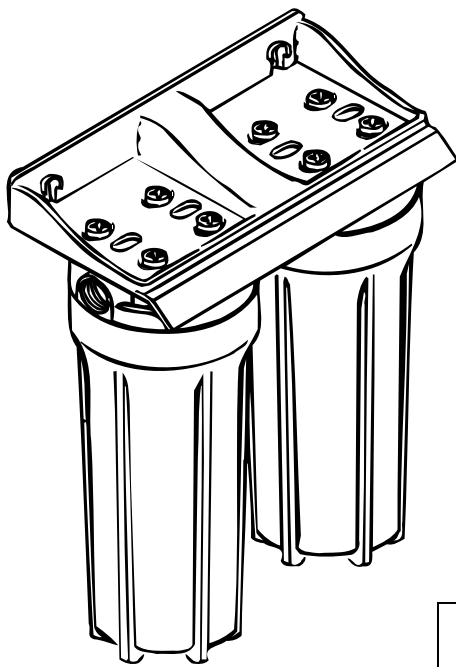
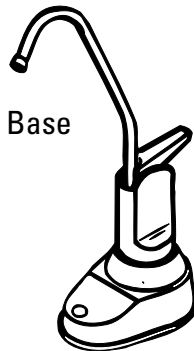

GNUT05B and GNUL30B are Tested and Certified by NSF International against ANSI/NSF Standard 42 for Particulate Reduction Class I, Chlorine Reduction Class I and Taste and Odor Reduction.

GNUL30B is Tested and Certified by NSF International against ANSI/NSF Standard 53 for Cyst, Turbidity and Lead Reduction.

GXEM01B is Tested and Certified by NSF International against ANSI/NSF Standard 42 for materials and structural integrity requirements only.



Congratulations! You are Now Part of the GE Family.

Welcome to the GE family. We're proud of our quality products and we are committed to providing dependable service. You'll see it in this easy-to-use Owner's Manual and you'll hear it in the friendly voices of our customer service department.

Best of all, you'll experience these values each time you use the Water Filtration system. That's important, because your new system will be part of your family for many years. And we hope you will be part of ours for a long time to come.

We thank you for buying GE. We appreciate your purchase, and hope you will continue to rely on us whenever you need quality appliances for your home.



IMPORTANT!

Fill out and return the Consumer Product Registration Card that is packed with this product. If you cannot find it, please send in the duplicate card printed in the back of this manual.



FOR YOUR RECORDS

Write the model and serial numbers here:

You can find them on the sump bracket.

Staple sales slip or cancelled check here.

Proof of the original purchase date is needed to obtain service under the warranty.



READ THIS MANUAL

Inside you will find many helpful hints on how to use and maintain your water system properly. Just a little preventive care on your part can save you a great deal of time and money over the life of your system.



IF YOU NEED SERVICE

You'll find many answers to common problems in the *Before You Call For Service* section. If you review our chart of *Troubleshooting Tips* first, you may not need to call for service at all.

If you do need service, you can relax knowing help is only a phone call away. A list of toll-free customer service numbers is included in the back section.

IMPORTANT SAFETY INFORMATION. READ ALL INSTRUCTIONS BEFORE USING.

⚠ WARNING! For your safety, the information in this manual must be followed to minimize the risk of property damage or personal injury.



SAFETY PRECAUTIONS

- Check with your local public works department for plumbing codes. You must follow these guidelines as you install the Water Filtration system.
- Use the Water Filtration system on a potable, safe-to-drink, home *COLD* water supply only. The filter cartridges will not purify the water, or make it safe to drink.
- **Do not** use on a hot water supply (100°F. max.).

⚠ WARNING: Do not use with water that is microbiologically unsafe or of unknown quality without adequate disinfection before or after the system. Systems certified for cyst reduction may be used on disinfected water that may contain filterable cysts.

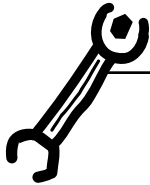

PROPER INSTALLATION

This Water Filtration system must be properly installed and located in accordance with the Installation Instructions before it is used.

- Install or store where it will not be exposed to temperatures below freezing or exposed to any type of weather. Water freezing in the system will damage it. Do not attempt to treat water over 100°F.

⚠ WARNING: Discard all unused and packaging material after installation. Small parts remaining after installation could be a choke hazard.

- Your Water Filtration system will withstand up to 125 pounds per square inch (psi) water pressure. If your house water supply pressure is higher than 100 psi, install a pressure reducing valve before installing the Water Filtration system.



Read and follow this Safety Information carefully.

SAVE THESE INSTRUCTIONS

Specification guidelines.

Many bad tastes and/or odors are removed from water using activated carbon filter cartridges. They are most often used to remove a chlorine taste and odor. They can also reduce other undesirable elements from drinking water supplies, such as organic chemical contaminants and lead.

NOTE: Small amounts of hydrogen sulfide (noticeable as “rotten egg” odor) may be reduced by taste and odor filters for a short time, but the carbon media is quickly exhausted. Other water conditioning equipment is usually required for the continuous treatment of hydrogen sulfide.

The Water Filtration system uses two filter cartridges.

Filter I. FXUSB—a sediment filter cartridge

- Reduces dirt, rust and sediment

Filter IIa. FXUTB—(Optional filter choices) a taste and odor filter cartridge

- 6000 gallons
- Reduces unpleasant tastes and odors
- Reduces 99.5% chlorine
- 1 micron, carbon block

IIb. FXULB—a lead/cyst filter cartridge

- 1250 gallons
- Reduces 95.7% lead
- Reduces 99.5% chlorine
- Reduces 99.98% filterable cysts (such as cryptosporidium and giardia)
- Reduces turbidity by 99.7%
- Absolute (>99.9%) one-micron carbon block

Minimum - Maximum Supply Water Pressure—40–125 pounds per square inch (psi)

Minimum - Maximum Supply Water Temperature—40–100°F

Inlet - Outlet—3/8" NPT, fittings and tubing included

Maximum Filtered Water Flow—0.6 gpm

Depending on the treatment needed for a specific water supply, the water filtration system can be customized using any combination of the preceding filter cartridges.

About the water filtration system.

Using the Water Filtration System and About the Filter Cartridge

The countertop faucet dispenses filtered drinking water when opened. It has a hand-operated, spring-loaded closed lever to prevent waste. You can keep the faucet open by pushing upward on the lever to lock it against the faucet spout.

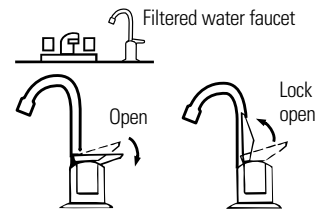

Filter Cartridge Life—Several variables determine how long the cartridges will last in your Water Filtration system. These include:

- 1 How much water you use.
- 2 How much sediment, taste and/or odor, lead, or other unwanted substance, is in the water.

No matter which Water Filtration system you have, you should replace the cartridges every six months, when indicated by the electronic indicator light on the base. In extremely poor water supplies, you may notice the return of the unwanted substance in your water before the six months are up. In this case the cartridges should be replaced immediately. If the system is also for lead or chemical contaminant removal, it is **MORE IMPORTANT** to replace the cartridges at least every six months.

NOTE: If the water supply contains high amounts of sediments, the carbon filters may plug with them, reducing filtered water flow to the system faucet. *Cartridge replacement is needed to restore flow.*

Electronic Indicator Light—The electronic indicator light on the base of the faucet is a six month timer that shows you when to replace the filter cartridges. When the battery pack is first installed, the indicator light will light briefly to show that the electronics are operating. If this does not happen, the batteries may be installed backwards or the leadwires are not connected.

After about six months, the indicator light begins to flash. It is time to replace the filter cartridges. When replacing the filter cartridges, also replace the batteries in the battery pack. Two “AA” batteries are required.

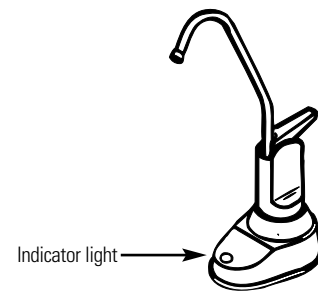

About the water filtration system.

Filter Cartridge Replacement

CAUTION: Never remove the sumps when water pressure is in the Water Filtration system.

- 1 **Close the water supply/saddle valve to the filter.** (See Fig. 1 in the *Installation Overview* section for location of the saddle valve.) Open the filtered water faucet.
- 2 Remove the sump, using the sump wrench tool provided, from the filter head by rotating the sump as shown in the below illustration. Be careful, the sump may be full of water. Be sure to keep the large o-ring seal.

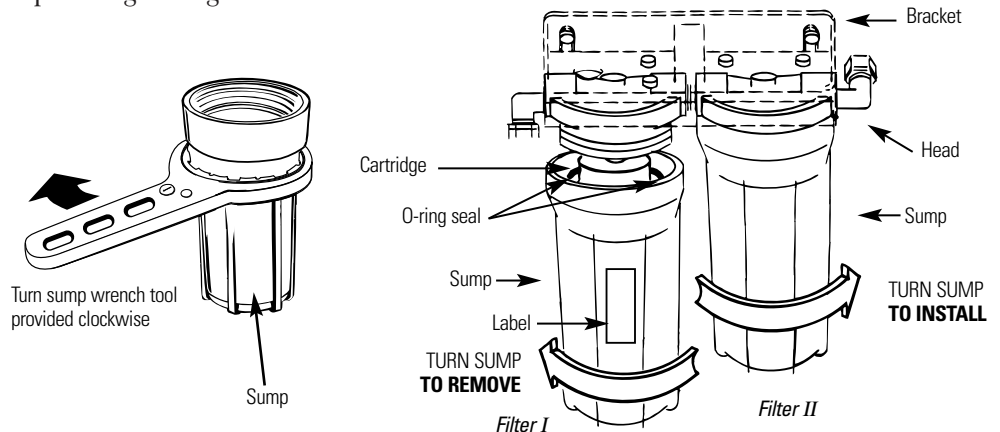

- 3 If you are replacing a filter cartridge, remove and discard the used filter cartridge.
- 4 Be sure the inside of the sump is clean. Thoroughly wash the inside of the sump with hot, soapy water and rinse.
- 5 Remove the wrapper from the new filter cartridge and insert the filter cartridge in the sump. Some cartridges fit either way, while others fit only one way. Observe markings on the cartridge.

NOTE: The Water Filtration system uses two different types of filter cartridges. Be sure to install them correctly.

The sediment (**FXUSB**) filter cartridge should always be placed in the *Filter I* sump.

- 6 Lightly lubricate the o-ring seal in the sump with clean silicone grease. Be sure it is fully seated in its groove.
 - 7 Hold the sump up to the filter head, aligning the center hole in the cartridge with the protrusion on the bottom of the head.
 - 8 Being careful not to cross-thread, rotate the sump onto the filter head and tighten securely by hand.
- NOTE:** If the sump will not tighten up to the head, you may have the cartridge in upside down. Take the cartridge out and check for correct orientation.
- 9 **Repeat steps 2 through 8 for the taste/odor (FXUTB) or lead/cyst (FXULB) filter cartridge in the Filter II sump.**

- 10 Turn on the filtered water faucet. Then, slowly open the water supply/saddle valve and allow the filter housing to fill.

- 11 Close the filtered water faucet. Then, check for leaks between the sump and the head.

NOTE: If leaking, turn off the water supply and turn on the filtered water faucet. Disassemble the filter and check the o-ring for cuts, flat spots, etc., and sealing surfaces for foreign material. Clean the o-ring and lightly lubricate with clean silicone grease. Carefully press into the groove in the sump.

- 12 If you are replacing the batteries, remove, properly discard and install two new "AA" alkaline batteries in the battery pack. Removing the batteries or momentarily disconnecting the leadwires resets the six month electronic timer.

- 13 The filter cartridges contain activated carbon. When new, turn on the filtered water faucet for ten minutes to flush the system.

Flush Procedure

Whenever water of unknown quality is passed through the GE Water Filtration system, filter elements should be discarded and the filtration system flushed.

Circumstances that may require flushing the system are:

- Boil-water advisory.
- Flooding of the GE Water Filtration system.
- Long-term non-use.

The procedure for flushing the GE Water Filtration system is:

- 1 See *Filter Cartridge Replacement* section and follow steps 1, 2, 3, and 4.
- 2 Next, reinstall the sumps (without the filter elements), turn water on, and flush water through the faucet for one minute.
- 3 Then, turn water off, remove sumps, empty water out of sumps and install new filter elements.
- 4 Follow steps 6–9 in the *Filter Cartridge Replacement* section to complete.

Installation Instructions

Important Installation Recommendations

Read entire manual. Failure to follow all guides and rules could cause personal injury or property damage.

- **Check with your local public works department for plumbing codes. You must follow their guides as you install the Water Filtration system.**
- **Use the Water Filtration system on a potable, safe-to-drink, home COLD water supply only. The filter cartridges will not purify water or make unsafe water safe to drink. DO NOT use on HOT water (100° F. max.).**
- **Protect the Water Filtration system and piping from freezing. Water freezing in the system will damage it.**
- **Your Water Filtration system will withstand up to 125 psi water pressure. If your house water supply pressure is higher than 100 psi during the day (it may reach higher levels at night), install a pressure reducing valve before the system.**

⚠ WARNING: Do not use with water that is microbiologically unsafe or of unknown quality without adequate disinfection before or after the system. GNUL30 is certified for cyst reduction and may be used on disinfected water that may contain filterable cysts. The water should be tested periodically to verify that the system is performing satisfactorily. Small parts remaining after the installation could be a choke hazard. Discard safely.

Tools and Materials Required for Installation

- Slotted and Phillips screwdrivers
- Pliers and adjustable jaw wrench
- Hand or battery powered drill and 1/4" bit (saddle valve installation)
- Electric drill and drill bit to drill 1"-1 1/4" hole (type as required) if mounting hole is needed for faucet

⚠ CAUTION: To avoid damaging the sink, consult a qualified plumber or installer for drilling procedures. Special drill bits may be needed for porcelain or stainless steel.

Contents included with the product:

- Water filter assembly, including mounting bracket and screws
- Product Literature (Owner's Manual and Installation, Product Data Sheet, Owner Product Registration Card)
- Water supply/saddle valve
- Filtered water faucet, for sink or countertop mounting including an electronic indicator faucet base and battery pack
- 3/8" tubing and fittings to make all needed connections
- Sump wrench

Installation Overview

Fig. 1

Locate the drinking water system on the cold water supply pipe, under the kitchen and/or bathroom sink, to filter the cold drinking water.

Shutoff valve

NOTE: To change the filter cartridge, you must turn off the water. A nearby shutoff valve is convenient. Most sinks already have shutoff valves on the supply pipes.

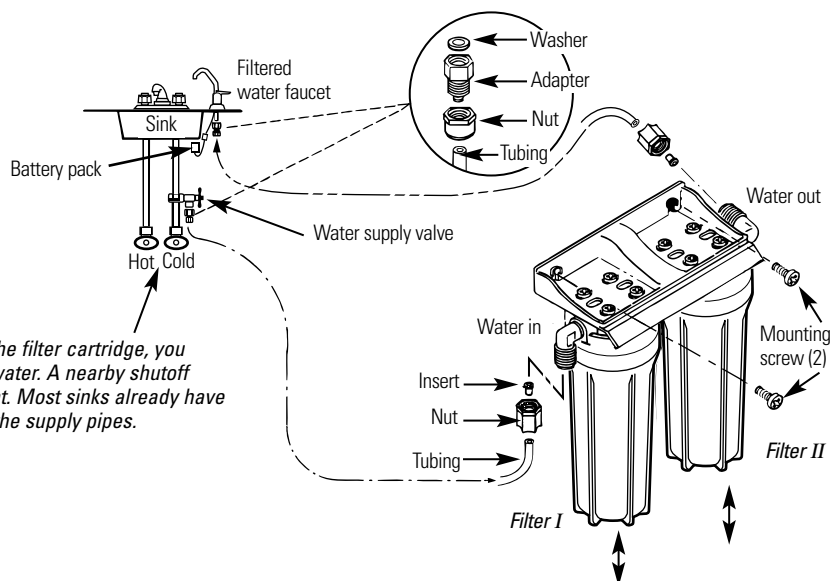

Step-by-step installation instructions.

Feed Water Supply

Check and comply with local plumbing codes as you plan, then install a cold feed water supply fitting. For new home installation using standard plumbing fittings, see Fig. 2A below. A typical installation for existing homes using the saddle valve is shown in Fig. 2B below.

A. PREFERRED INSTALLATION

1 Turn off the cold water supply.

2 Complying with plumbing codes, install a fitting on the cold water pipe to adapt 3/8" OD tubing. A typical connection is shown in Fig. 2A (parts not included). Make sure a water supply valve is used.

Fig. 2A. Preferred water supply connection (using compression fitting)

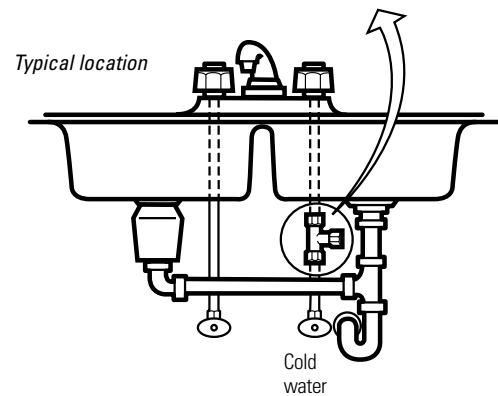
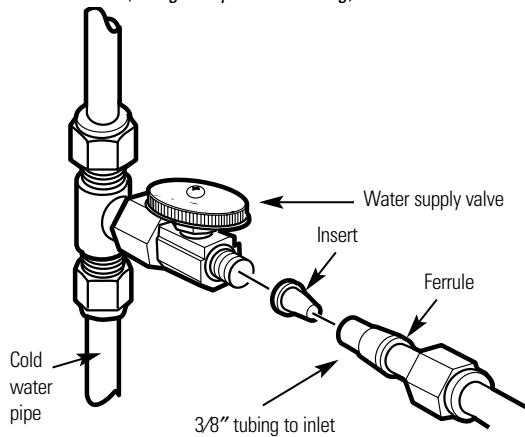

B. OPTIONAL HOME INSTALLATION Where codes permit

NOTE: Codes in the state of Massachusetts require installation by a licensed plumber and do not permit the use of the saddle valve. For installation, use plumbing code 248-CMR of the Commonwealth of Massachusetts.

1 Turn off the cold water supply and attach saddle valve as shown in Fig. 2B.

2 Close the water supply valve by turning the handle clockwise.

3 Open the main water supply valve and several house faucets to purge air from the system. Close faucets when water runs smoothly.

⚠ DANGER: To protect yourself from serious injury or fatal shock, use a battery powered hand drill only to make the hole. **DO NOT USE AN ELECTRIC DRILL.**

Fig. 2B. Optional water supply connection (using saddle valve)

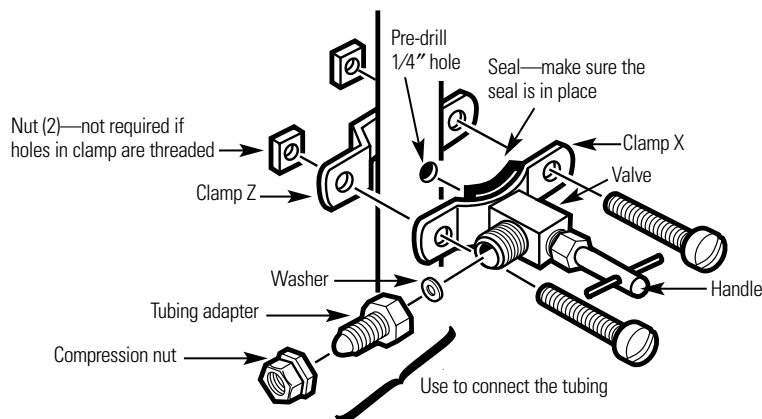

Step-by-step installation instructions.

Electronic Faucet Installation

Be sure there is room underneath the sink to make the needed connections. Select one of the following places to install the faucet:

- IN an existing sink spray attachment or soap dispenser hole.
- IN a hole to be drilled in the sink top.
- IN a hole to be drilled in the countertop, next to the sink.

NOTE: Looking at Fig. 3D, be sure the faucet base will fit flat against the surface at the selected location so the gasket will seal. The base may have to be angled sideways or diagonally.

- 1 If drilling is needed, make a 1"-1 1/4" dia. hole. **Be sure to use the proper procedure for drilling porcelain or stainless steel. Special drill bits may be needed.**
- 2 Looking at Fig. 3A, insert a screw into the NON-SLOTTED base mounting hole. Turn a flat nut a few turns onto the screw.
- 3 Position the base gasket over the mounting hole. Set the base on the gasket, routing the leadwire through the mounting hole. Holding the flat nut under the sink with one finger, tighten the screw until just snug.
- 4 Turn the remaining flat nut a few turns onto the other screw. Position the screw in the slotted base mounting hole and tighten until snug. Make sure the gasket position is properly aligned and **carefully tighten** both screws until the base is held firmly in place. **Do not overtighten** and break the base.
- 5 Assemble the top faucet base and hex nut onto the faucet stud (Fig. 3C). Tighten the nut until snug.
- 6 Insert washer into tubing adapter. Securely tighten to faucet stud.
- 7 Feed the length of 3/8" OD tubing from the bottom, up through the faucet base. Connect to the tubing adapter as shown in Fig. 3D., tightening the compression nut securely.
- 8 Remove the short shipping tube and insert the spout into the faucet body.
- 9 Lower the faucet assembly and lock into place on the faucet base.

Fig. 3A.

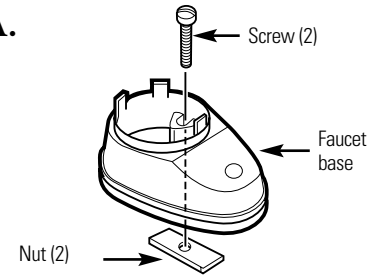

Fig. 3B.

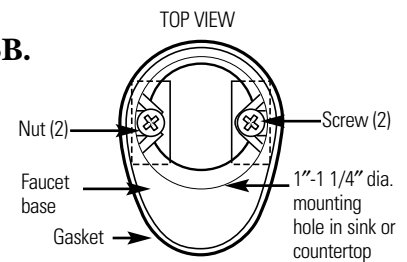

Fig. 3C.

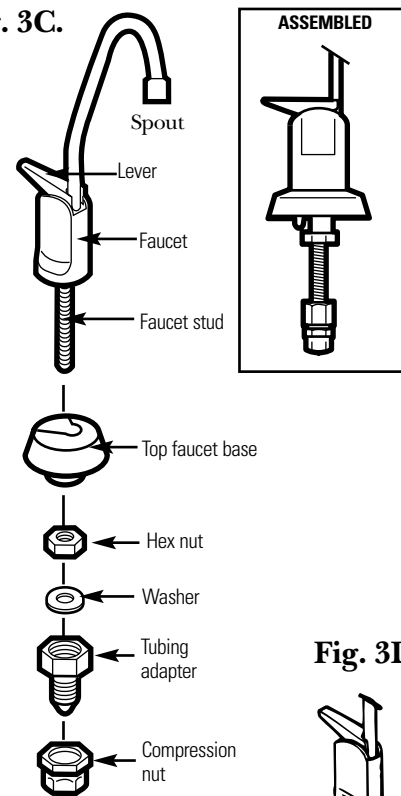
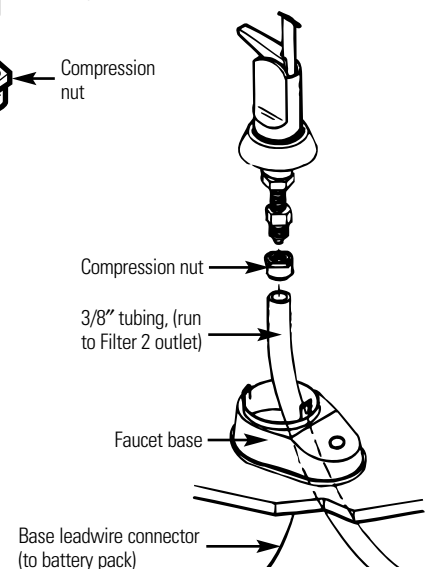

Fig. 3D.



Mounting Bracket to Cabinet Wall

The bracket can be used as a template for marking the location of the mounting screws. When determining the location of the bracket make sure you leave 1-1/2" to 2" of free area under the sumps to allow for sump removal and enough space on either side to make the tubing connections.

Make Tubing Connections

- 1 Run the length of 3/8" tubing, connected to the bottom of faucet, to the filter system outlet, Fig.1 in the *Installation Overview* section. Allow enough slack in the tubing to be able to place the system on the floor in front of the sink. Measure and cut the end of the tubing square.
- 2 Slide a compression nut onto the end of the tubing and push a tubing insert into the tubing.
- 3 Connect the tubing and tighten the compression nuts securely.
- 4 Repeat the preceding steps to connect a length of tubing between the filter system inlet and the water supply/saddle valve, Fig. 1 in the *Installation Overview* section.

Fig. 4

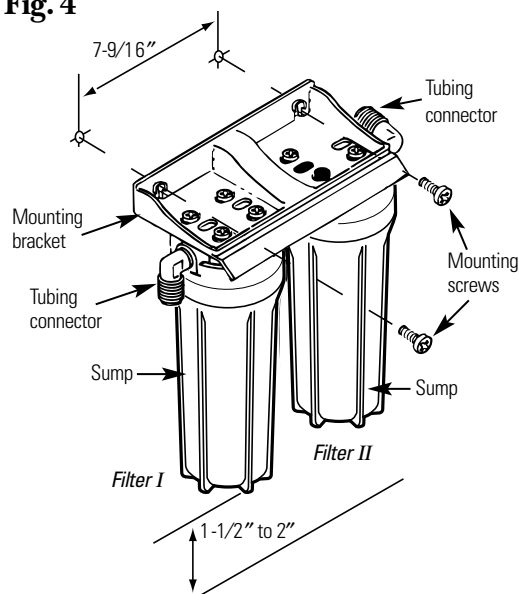

Battery Pack Installation and Connection

- 1 In a dry location, within reach of the electronic base 3' leadwire, select a place for the battery pack (see Fig. 1 on page 8). The battery pack attaches to most surfaces, using the included "sticky-back" Velcro™ strip.
- 2 The battery pack uses two size "AA" batteries. Check to be sure they are installed correctly. Then, remove the paper backing on the Velcro™ strip and secure the pack in place.
- 3 Fasten electronic base leadwire and battery pack connector together.

Step-by-step installation instructions.

Filter Cartridge Installation or Replacement

- ⚠ CAUTION:** Never remove sumps with water pressure in the Water Filtration system.
- 1 **Close the water supply/saddle valve (Fig. 1 and 2A) to the filter.** Open the filtered water faucet.
 - 2 Turn the sump off of the filter head as shown (use the sump wrench provided). Be careful, the sump is full of water. Locate and save the large o-ring seal. Remove and discard the used filter cartridge.
 - 3 Be sure the inside of the sump is clean. Thoroughly wash with hot, soapy water and rinse.
 - 4 Remove the wrapper and labels from the new filter cartridge and insert the filter cartridge in the sump. Some cartridges fit either way, while others fit only one way. Observe markings on the end of the cartridge. The sediment (**FXUSB**) filter cartridge should always be placed in the *Filter I* sump.
 - 5 Lightly lubricate the o-ring seal, in the sump, with clean silicone grease. Be sure it is fully seated in its groove.
 - 6 Hold the sump up to the filter head, aligning the center hole in the cartridge with the protrusion on the bottom of the head.
- NOTE:** If the sump will not tighten up to the head, you may have the cartridge in upside down. Take the cartridge out and check the markings on the end of the cartridge for correct orientation.
- 7 Being careful not to cross-thread, turn the sump onto the filter head and hand tighten securely (see Fig. 5).
 - 8 **Repeat steps 2 through 7 for the taste/odor (FXUTB) or lead/cyst (FXULB) filter cartridge in the Filter II sump.**
 - 9 Open the filtered water faucet. Then, slowly open the water supply/saddle valve and allow the filter housing to fill.
 - 10 Close the filtered water faucet. Then, check for leaks between the sump and the head.
- NOTE:** If leaking, turn off the water supply and open the filtered water faucet. Then, disassemble the filter and check the o-ring for cuts, flat spots, etc., and sealing surfaces for foreign material. Clean the o-ring and lubricate with clean silicone grease. Carefully press into the groove in the sump.
- 11 Remove and install two new “AA” alkaline batteries in the battery pack. Removing the batteries or momentarily disconnecting the leadwires resets the six month electronic base timer.
 - 12 The filter cartridges contain activated carbon. When new, open the filtered water faucet for ten minutes to flush the system.

Fig. 5

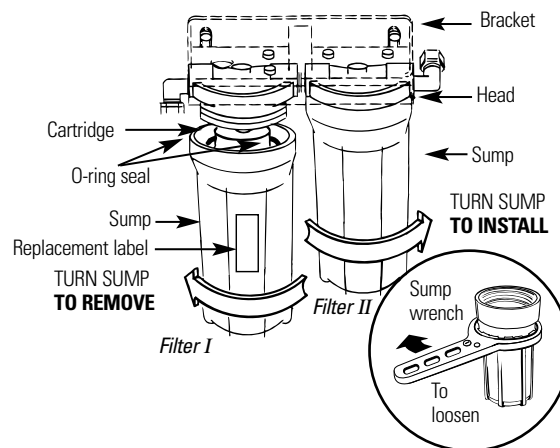

Before you call for service...



Troubleshooting Tips
 Save time and money! Review the chart below first and you may not need to call for service.

Problem	Possible Causes	What To Do
Water contains tiny black particles	New filter cartridges contain activated carbon, which is a harmless black powder.	<ul style="list-style-type: none"> • Turn on the filtered water faucet and allow these harmless carbon particles to purge from the cartridge. Turn off the faucet when the water is clear.
Water has air bubbles and is cloudy	Air in system after installation.	<ul style="list-style-type: none"> • Will go away after water runs for a while.
Indicator light on the faucet base is flashing	Six months usage has occurred. This is the maximum life of the filter cartridges.	<ul style="list-style-type: none"> • Replace both filter cartridges and batteries in the battery pack.
Indicator light on the faucet base is not working	The faucet base leadwire is not connected to the battery pack leadwire.	<ul style="list-style-type: none"> • Connect.
	Batteries may need to be replaced or they may have been installed incorrectly.	<ul style="list-style-type: none"> • Observe orientation markings on the holder and install correctly. Replace batteries if they are old.
	Leadwires damaged.	<ul style="list-style-type: none"> • Inspect and repair as needed.
Chlorine taste and /or odor in the product water	The filter cartridges are no longer removing chlorine from the water supply.	<ul style="list-style-type: none"> • Replace both filter cartridges and batteries in the battery pack.

Customer Service	Troubleshooting Tips	Installation Instructions	Operating Instructions	Safety Instructions
-------------------------	-----------------------------	----------------------------------	-------------------------------	----------------------------

Notes.

GE Service Protection Plus™

GE, a name recognized worldwide for quality and dependability, offers you Service Protection Plus™—comprehensive protection on all your appliances—**No Matter What Brand!**

Benefits Include:

- Backed by GE
- All brands covered
- Unlimited service calls
- All parts and labor costs included
- No out-of-pocket expenses
- No hidden deductibles
- One 800 number to call

***We'll Cover Any Appliance.
Anywhere. Anytime.****

You will be completely satisfied with our service protection or you may request your money back on the remaining value of your contract. No questions asked. It's that simple.

Protect your refrigerator, dishwasher, washer and dryer, range, TV, VCR and much more—**any brand!** Plus there's no extra charge for emergency service and low monthly financing is available. Even icemaker coverage and food spoilage protection is offered. You can rest easy knowing that all your valuable household products are protected against expensive repairs.

Place your confidence in GE and call us in the U.S. toll-free at **800-626-2224** for more information.

*All brands covered, up to 20 years old, in the continental U.S.

 Cut here

Please place in envelope and mail to:

General Electric Company
Warranty Registration Department
P.O. Box 34070
Louisville, KY 40232-4070

Parts List.

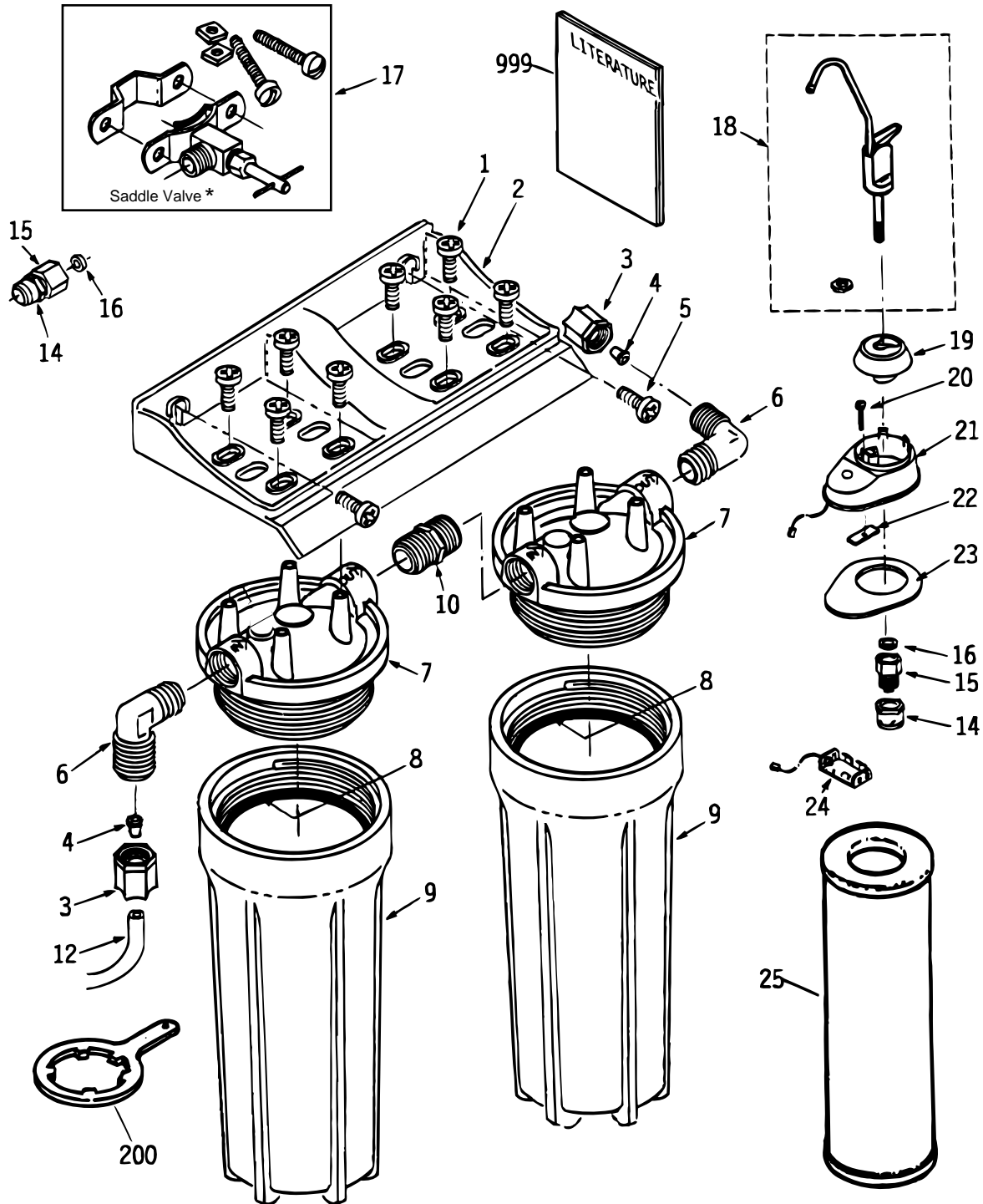

***NOTE:** Codes in the state of Massachusetts require installation by a licensed plumber and do not permit the use of the saddle valve. For installation, use plumbing code 248-CMR of the Commonwealth of Massachusetts.

REF. NO.	PART NO.	PART DESCRIPTION	G	G	G
			N	N	X
			U	U	E
			L	T	M
			3	0	0
			0	5	1
			B	B	B
			0	0	0
			1	1	1
0001	WS02X10001	SCREW #10-14 X 3/4"	8	8	8
0002	WS28X10010	MOUNTING BRACKET	1	1	1
0003	WS22X10008	NUT 3/8" TUBE	2	2	2
0004	WS22X10007	INSERT 3/8" TUBE	2	2	2
0005	WS02X10003	SCREW #10-14 X 1/4"	2	2	2
0006	WS22X10002	ELBOW 3/8" NPT X 3/8"	2	2	2
0007	WS19X10011	HEAD	2	2	2
0008	WS03X10001	O-RING 3-3/8" X 3-5/8"	2	2	2
0009	WS30X10002	SUMP	2	2	2
0010	WS22X10003	NIPPLE 3/8" NPT X 1-1/2"	1	1	1
0012	WS07X10008	TUBING 3/8" X 20 FT-WH	1	1	1
0014	WS02X10004	NUT 3/8"	2	2	2
0015	WS03X10003	ADAPTER TUBING	2	2	2
0016	WS03X10002	WASHER	2	2	2
0017	WS15X10008	SADDLE VALVE /SUPPLY	1	1	1
0018	WS15X10002	FAUCET ASM.	1	1	1
0019	WS10X10001	BASE FAUCET, TOP	1	-	-
	WS10X10008	TOP FAUCET BASE BLACK	-	1	1
0020	WS02X10007	SCREW #6-32 X 1-3/8"	2	2	2
0021	WS10X10002	BASE FAUCET KIT	1	1	1
0022	WS02X10008	NUT	2	2	2
0023	WS08X10003	GASKET FAUCET	1	1	1
0024	WS06X10001	HOLDER BATTERY	1	1	1
0025	FXUTB	FILTER-TASTE & ODOR	-	1	-
	FXUSB	FILTER-SEDIMENT	1	1	-
	FXULB	FILTER-LEAD/CYST	1	-	-
0200	WX5X140	WRENCH SUMP	1	1	1
0999	49-50023	PM MANUAL USE & CARE/ INSTALLATION	1	1	1

GE Water Filtration System Warranty.



All warranty service provided by our SmartWater™ Authorized Servicer Network.
For service, call 800-GE-CARES.

For The Period Of: GE Will Replace:

One Year
From the date of the original purchase
Model GXEM01B

Any part of the Water Filtration system (excluding filters) which fails due to a defect in materials or workmanship. During this **limited one-year warranty**, GE will also provide, **free of charge**, all labor (does not include service trip to home) to replace the defective part.

One Year
From the date of the original purchase
Models GNUT05B and GNUL30B

Any part of the Water Filtration system (excluding filters) which fails due to a defect in materials or workmanship. During this **full one-year warranty**, GE will also provide, **free of charge**, all labor and in-home service to replace the defective part.

What GE Will Not Cover:

- Service trips to your home to teach you how to use the product.
- Improper installation.
- Failure of the product if it is abused, misused, or used for other than the intended purpose or used commercially.
- Use of this product where water is microbiologically unsafe or of unknown quality, without adequate disinfection before or after the system. Systems certified for cyst reduction may be used on disinfected water that may contain filterable cysts.
- Filter cartridges.
- Replacement of house fuses or resetting of circuit breakers.
- Damage to the product caused by accident, fire, floods or acts of God.
- Incidental or consequential damage to personal property caused by possible defects with this appliance.

This warranty is extended to the original purchaser and any succeeding owner for products purchased for home use within the USA. In Alaska, the warranty excludes the cost of shipping or service calls to your home.

Some states do not allow the exclusion or limitation of incidental or consequential damages. This warranty gives you specific legal rights, and you may also have other rights which vary from state to state. To know what your legal rights are, consult your local or state consumer affairs office or your state's Attorney General.

Warrantor: General Electric Company, Louisville, KY 40225

Safety Instructions

Operating Instructions

Installation Instructions

Troubleshooting Tips

Customer Service

Service Telephone Numbers.



GE Answer Center® 800.626.2000

The GE Answer Center® is open 24 hours a day, 7 days a week.



In-Home Repair Service 800-GE-CARES (800-432-2737)

Expert GE repair service is only a phone call away.



Special Needs Service 800.626.2000

800-TDD-GEAC (800-833-4322)

GE offers, free of charge, a brochure to assist in planning a barrier-free kitchen for persons with limited mobility.



Service Contracts 800-626-2224

Purchase a GE service contract while your warranty is still in effect and you'll receive a substantial discount. GE Consumer Service will still be there after your warranty expires.

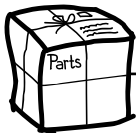

Parts and Accessories 800-626-2002

Individuals qualified to service their own appliances can have parts or accessories sent directly to their homes (VISA, MasterCard and Discover cards are accepted).

Instructions contained in this manual cover procedures to be performed by any user. Other servicing generally should be referred to qualified service personnel. Caution must be exercised, since improper servicing may cause unsafe operation.



Service Satisfaction

If you are not satisfied with the service you receive from GE:

First, contact the people who serviced your appliance.

Next, if you are still not pleased, write all the details—including your phone number—to:

Manager, Customer Relations
 GE Appliances
 Appliance Park
 Louisville, KY 40225