

Installation Instructions / Warranty

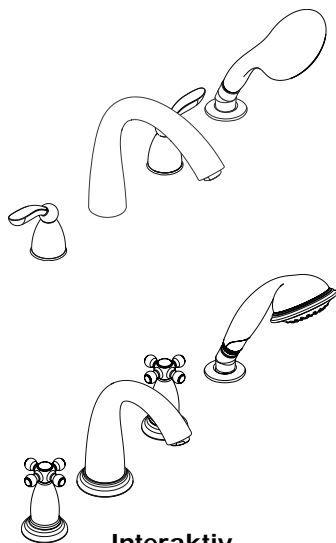

Interaktiv
Retroaktiv

4-Hole Roman Tub Trim

hansgrohe

Interaktiv & Retroaktiv 4-Hole Roman Tub Trim

These instructions cover the following trim kits:

Interaktiv

Solaris	06665XX0
Stratos	06667XX0
Metro	06669XX0
Interaktiv S	06876XX0

Retroaktiv

	Swing	Tango	Limbo
Cross handle	06125XX0	06048XX0	06113XX0
Scroll handle	06124XX0	06047XX0	06112XX0
Lever handle	06123XX0	06046XX0	06110XX0
Proaktiv*	06322XX0	06319XX0	06312XX0

*handles not included, sold separately

Installation considerations

4-hole roman tub rough valve 06646000 must be installed, and the mounting surface completed and made watertight before installation of this trim kit

Backflow prevention is provided by a check valve installed in the handshower elbow.

Flow rate of handshower 2.5 gpm

Make sure that the water is turned off at the main before installing this trim kit.

Interaktiv

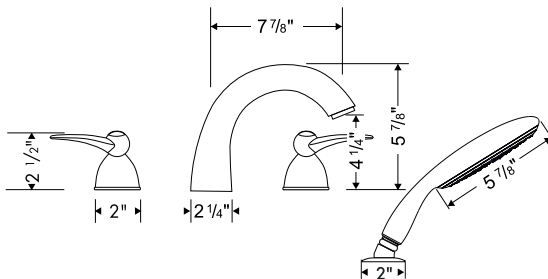

06669XX0 shown

Retroaktiv

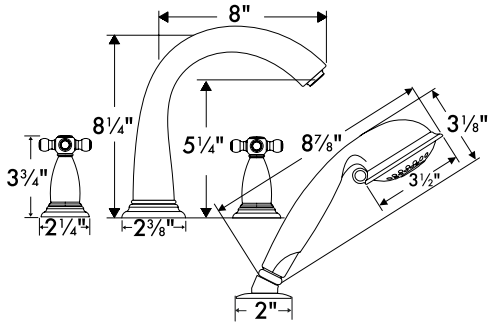

Swing - Cross handles shown

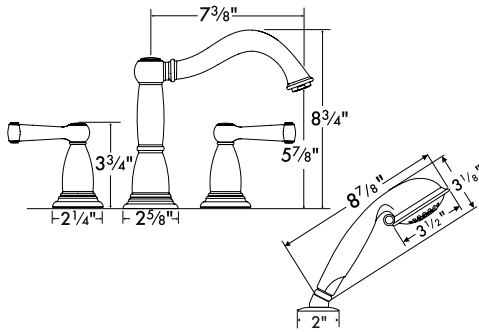

Tango - Swing handles shown

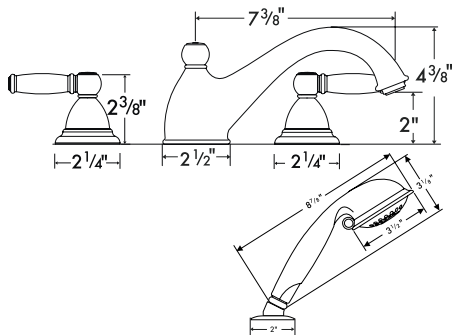

Limbo - Lever handles shown

Install the Handles

Remove the plaster shields from the hot and cold valves.

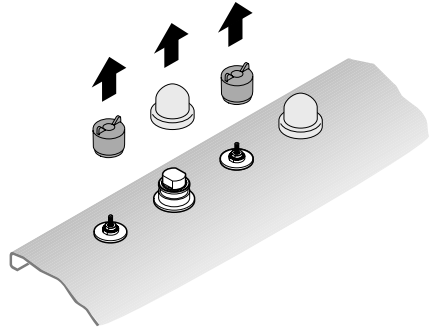

Retroaktiv only: Install the deco rings on the handles.

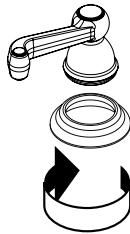

All models: Position the handle over the valve stem with the lever in the desired "off" position.

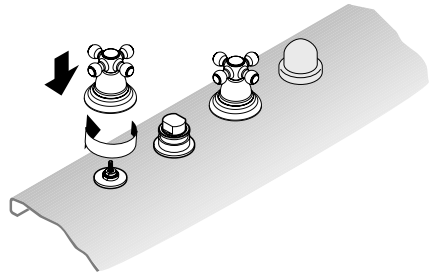

Holding the lever in place with one hand, use your other hand to turn the "bell" and screw it down over the valve.

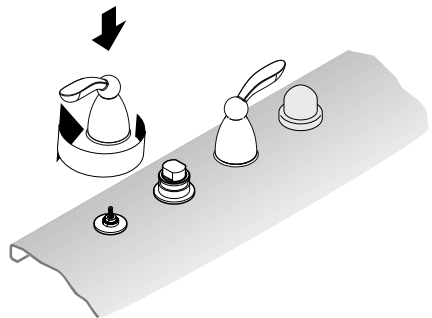

Assemble the Diverter and Spout

Remove the plaster shield from the spout tee. Remove the brass plug from the tee.

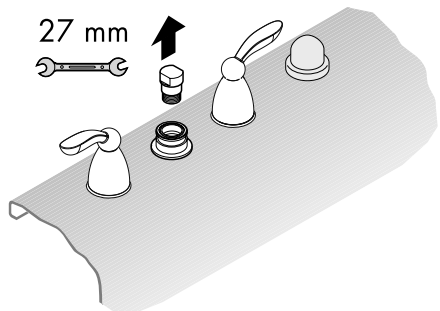

Interaktiv and Swing

Screw the nut onto the diverter. Screw the shorter threaded end of the threaded rod into the nut. Slide the rod trim onto the rod and screw into place so that a few threads protrude from the top.

Firmly press the diverter assembly straight into the spout tee until it is fully seated.

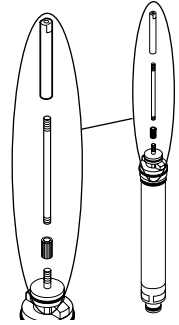

Swing only: install the spout deco ring on the spout. Make sure that the set screw hole in the deco ring lines up with the set screw hole in the spout.

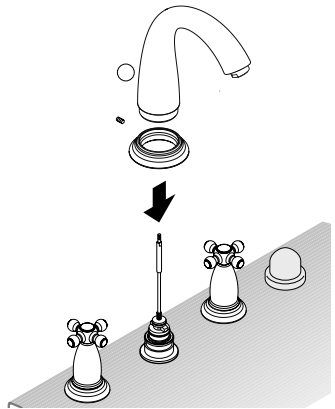

Press the spout over the tee and diverter. Install the set screw and tighten it with a 3mm Allen wrench (included).

CAUTION: do not overtighten the set screw or the o-rings on the diverter will deform, which will cause a leak.

Install the diverter knob.

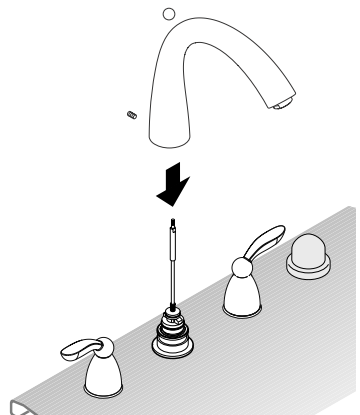

Limbo

Screw the socket onto the diverter.

Insert the ball rod into the socket.

Press the white plastic retainer clip over the ball rod. Press into place over the socket.

Press the diverter assembly firmly into the spout tee until it is fully seated.

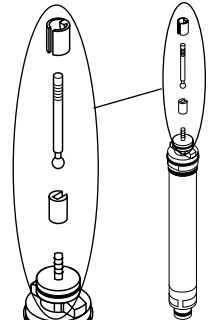

Firmly press the spout over the tee and diverter. Tighten the set screw with the included 3 mm Allen wrench.

CAUTION: do not overtighten the set screw or the o-rings on the diverter will deform, which will cause a leak.

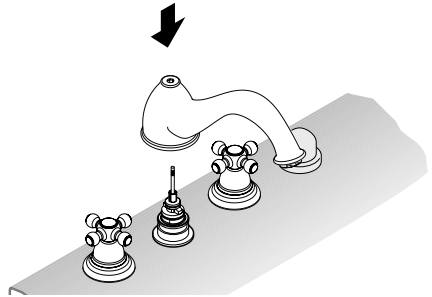

Use the included wrench to hold the threaded rod steady. (It may be necessary to use a needle-nosed plier to pull up on the threaded rod to expose the wrench flats).

Install the diverter knob.

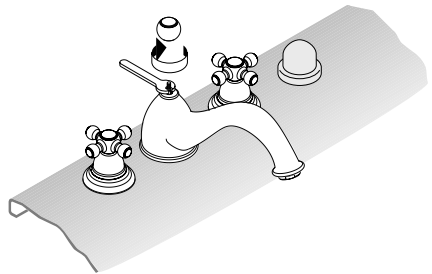

Tango

Install the pin onto the diverter.

Press the guide bushing firmly into place. The hole in the pin should be clearly visible through the slot in the guide bushing.

Press the diverter assembly firmly into the spout tee until it is fully seated. Turn the guide bushing so that the slot faces the rear of the spout.

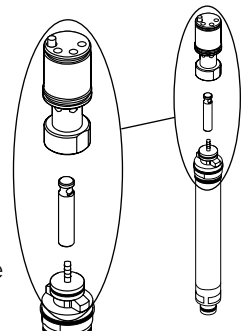

Firmly press the spout over the tee and diverter. Tighten the set screw with the included 3 mm Allen wrench.

CAUTION: do not overtighten the set screw or the o-rings on the diverter will deform, which will cause a leak.

Install the pull rod. The threaded end of the pull rod must go into the hole in the pin.

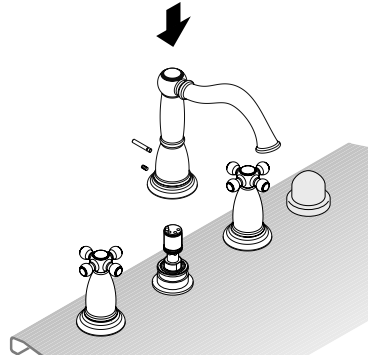

Install the Handshower Holder Escutcheon and Handshower

Remove the plaster shield from the handshower holder. Pull out on the handshower hose.

Screw the handshower holder escutcheon into place. Install the elbow.

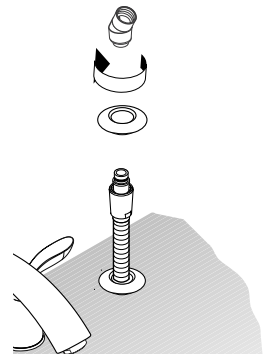

Place a black rubber hose washer in the elbow. Screw the handshower into the elbow.

Guide the handshower into the holder.

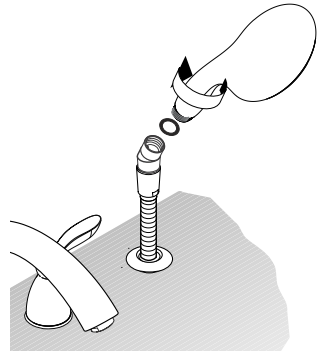

User Instructions

Turn the left handle to obtain hot water, the right handle to obtain cold water.

When the water is turned on, it will come through the spout. To obtain water from the handshower, pull up on the diverter knob.

The diverter will reset to the spout position when the water is turned off.

Replacement Parts

Retroaktiv

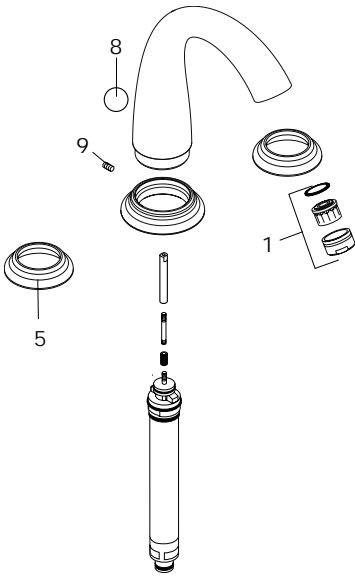

Swing

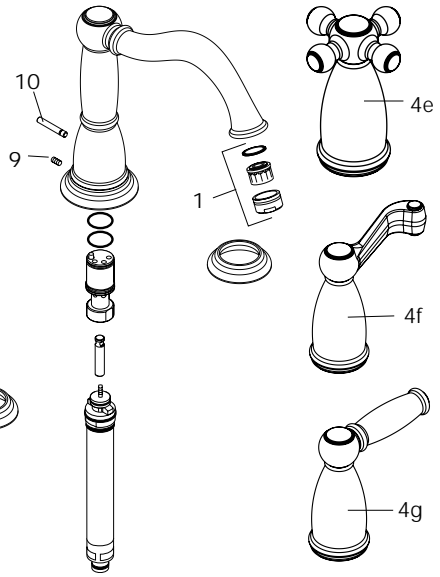

Tango

Limbo

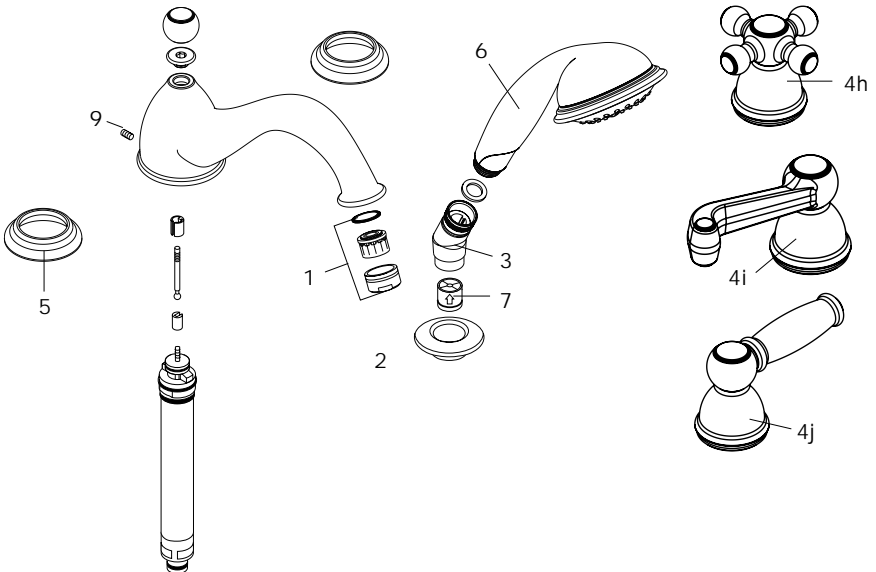

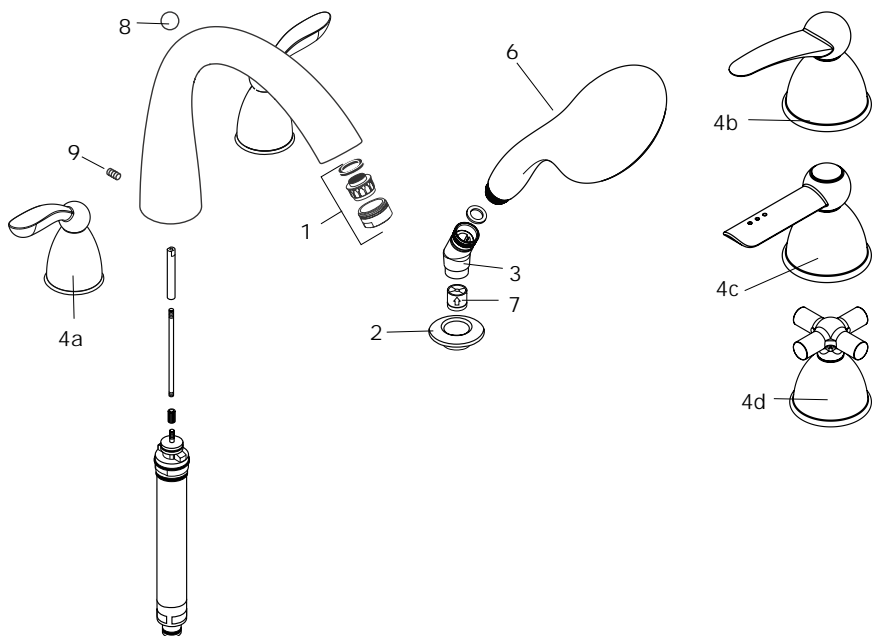

Interaktiv

1	aerator	13956XX0
2	handshower holder escutcheon	97159XX0
3	elbow	28071XX0
4	handle set	
4a	Solaris	06850XXX
4b	Stratos	06852XXX
4c	Metro	06853XXX
4d	Interaktiv S	06957XXX
4e	High cross	06326XXX
4f	High scroll	06325XXX
4g	High lever	06324XXX
4h	Low cross	06305XXX
4i	Low scroll	06034XXX
4j	Low lever	06303XXX
5	Retroaktiv handle deco ring	88600XX0
6	handshower - Raindance AIR 1-Jet	
	handshower - Retroaktiv	06127XX0
7	check valve	94074000
8	diverter knob	94102XXX
9	set screw	96029000
10	diverter knob - Tango	97144XXX

Scale Removal

The Raindance Air 1-jet handshower incorporates the Rubit™ cleaning system. If scale deposits are noticed in the spray channels, turn the water on lightly and rub the spray channels with a finger or a sponge.

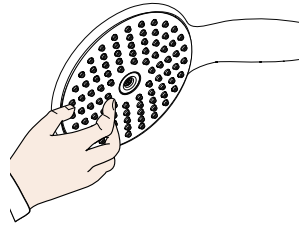

If scale deposits are noticed on the spray face, pour about 3/4" of a commercial scale remover, such as Lime-Away™ or CLR™, into a shallow dish. Dilute the remover according to the label instructions.

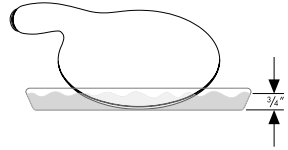

Soak only the spray face in the solution for the amount of time specified on the label.

Rinse the handshower with clear water.

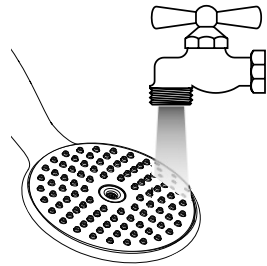

Reinstall the handshower. Turn on the water and allow the handshower to flush for at least one minute.

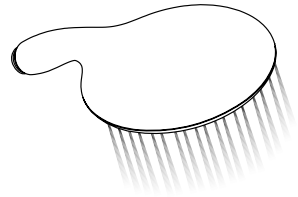

Troubleshooting

Problem

Water drips from spout for a few minutes after the unit is turned off.

Possible Cause

Normal clearing of spout.
Debris in aerator.

Solution

Not a problem.
Remove and clear debris.

Water drips constantly from spout when water is turned off.

Valve cartridge(s) faulty.

Replace valve cartridge(s).

Water pools at base of spout.

Diverter faulty

Replace diverter.

Cleaning Recommendation for Hansgrohe Products

Modern faucetry and shower products utilize a combination of materials to comply with the needs of the market with regard to design and functionality.

To avoid damage, it is necessary to use some caution when cleaning. Damage caused by improper treatment is not covered under the Hansgrohe warranty.

Cleaning Materials for Faucets and Showers

- To remove lime scale, use only products made specifically for that purpose. Always follow the manufacturer's instructions when using.
- Do not use cleaners that contain hydrochloric, formic, acetic, or phosphoric acids, as these will cause considerable damage to finishes and to plastic components.
- Never mix cleaning materials.
- Never use cleaners containing abrasives. Do not use abrasive cleaning cloths, pads, or sponges.

Cleaning Procedures

- Clean your faucets and shower products as and when required. Regular cleaning will prevent scale buildup and water spotting.
- Follow the label instructions. Do not allow any cleaner to remain on the product for longer than necessary.
- When using spray cleaners, spray first onto a sponge or cloth – do not spray directly onto the product.
- After cleaning, rinse thoroughly with clear water to remove any cleaner residue.

Important

- Soap and shampoo residue can also cause damage to the product. Rinse well with clean water after use.
- If the surface is already damaged, harsh cleaning materials will cause further damage.

Limited Lifetime Consumer Warranty

This product has been manufactured and tested to the highest quality standards by Hansgrohe, Inc. ("Hansgrohe"). This warranty is limited to Hansgrohe products which are purchased by a consumer in the United States after March 1, 1996, and installed in either the United States or Canada.

WHO IS COVERED BY THE WARRANTY

This warranty extends to the original consumer purchaser only.

WHAT IS COVERED BY THE WARRANTY

This warranty covers only your Hansgrohe manufactured product. Hansgrohe warrants this product against defects in material or workmanship as follows: Hansgrohe will repair at no charge for parts only or, at its option, replace any product or part of the product which proves defective because of improper workmanship and/or material, under normal installation, use, service and maintenance. If Hansgrohe is unable to provide a replacement and repair is not practical or cannot be timely made, Hansgrohe may elect to refund the purchase price in exchange for the return of the product.

LENGTH OF WARRANTY

Replacement or repaired parts of products will be covered for the term of this warranty as stated in the following two sentences. If you are a consumer who purchased the product for use primarily for personal, family, or household purposes, this warranty extends for as long as you own the product and the home in which the product is installed. If you purchased the product for use primarily for any other purpose, including, without limitation, a commercial purpose, this warranty extends only (i) for 1 year, with respect to Interaktiv and Retroaktiv products, and (ii) for 5 years, with respect to AXOR, ShowerPower and Pharo products.

THIS WARRANTY DOES NOT COVER, AND HANSGRÖHE WILL NOT PAY FOR:

- A. Conditions, malfunctions or damage not resulting from defects in material or workmanship.
- B. Conditions, malfunctions or damage resulting from (1) improper installation, improper maintenance, misuse, abuse, negligence, accident or alteration, or (2) the use of abrasive or caustic cleaning agents or "no rinse" cleaning products, or the use of the product in any manner contrary to the product instructions.

- C. Labor or other expenses for the disconnection or return of the product for warranty service, or for installation or reinstallation of the product.
- D. Accessories or related products not manufactured by Hansgrohe.

TO OBTAIN WARRANTY SERVICE

Contact your Hansgrohe retailer, or write to Technical Service at:

Hansgrohe Inc.
1492 Bluegrass Lakes Parkway
Alpharetta GA 30004

Or, call Hansgrohe toll-free at (800) 334-0455.

In requesting warranty service, you will need to provide

1. The sales receipt or other evidence of the date and place of purchase.
2. A description of the problem.
3. Delivery of the product or the defective part, postage prepaid and carefully packed and insured, to Hansgrohe Inc. 1492 Bluegrass Lakes Parkway, Alpharetta, Georgia 30004, Attention: Technical Service, if required by Hansgrohe.

When warranty service is completed, any repaired or replacement product or part will be returned to you postage prepaid.

EXCLUSIONS AND LIMITATIONS

REPAIR OR REPLACEMENT (OR, IN LIMITED CIRCUMSTANCES, REFUND OF THE PURCHASE PRICE) AS PROVIDED UNDER THIS WARRANTY IS THE EXCLUSIVE REMEDY OF THE PURCHASER. HANSGROHE NEITHER ASSUMES NOR AUTHORIZES ANY PERSON TO CREATE FOR IT ANY OBLIGATION OR LIABILITY IN CONNECTION WITH THIS PRODUCT.

HANSGROHE SHALL NOT BE LIABLE TO PURCHASER OR ANY PERSON FOR ANY INCIDENTAL, SPECIAL, OR CONSEQUENTIAL DAMAGES, ARISING OUT OF BREACH OF THIS WARRANTY OR ANY IMPLIED WARRANTY (INCLUDING MERCHANTABILITY).

Some States do not allow the exclusion or limitation of incidental or consequential damages, so the above limitation or exclusion may not apply to you.

This warranty gives you specific legal rights, and you may have other rights which vary from State to State.

You may be required by law to give us a reasonable opportunity to correct or cure any failure to comply before you can bring any action in court against us under the Magnuson-Moss Warranty Act.

PRODUCT INSTRUCTIONS AND QUESTIONS

Upon purchase or prior to installation, please carefully inspect your Hansgrohe product for any damage or visible defect. Prior to installing, always carefully study the enclosed instructions on the proper installation and the care and maintenance of the product. If you have questions at any time about the use, installation, or performance of your Hansgrohe product, or this warranty, please call or write to us at the toll-free number and address printed above.

hansgrohe

Hansgrohe, Inc. • 1490 Bluegrass Lakes Parkway • Alpharetta, GA 30004
Tel. 770 360-9880 • Fax 770 360 9887

www.hansgrohe-USA.com