



user's information manual

SINGLE PACKAGE ROOFTOP
GAS HEATING/
ELECTRIC COOLING UNITS

581B
DuraPac Plus Series
Sizes 036-150
3 to 12¹/₂ Tons

Cancels: OM11-19

OM11-22
3/15/02

NOTE TO INSTALLER:

This manual should be left with the equipment owner.

WARNING: If the information in this manual is not followed exactly, a fire or explosion may result causing property damage, personal injury or loss of life.

- Do not store or use gasoline or other flammable vapors and liquids in the vicinity of this or any other appliance.
- **WHAT TO DO IF YOU SMELL GAS**
 - Do not try to light any appliance.
 - Do not touch any electrical switch; do not use any phone in your building.
 - Immediately call your gas supplier from a neighbor's phone. Follow the gas supplier's instructions.
 - If you cannot reach your gas supplier, call the fire department.
- Installation and service must be performed by a qualified installer, service agency or the gas supplier.

WARNING: Improper installation, adjustment, alteration, service, or maintenance could cause property damage, serious injury or death. Refer to this manual. For assistance or additional information, consult a qualified installer, service agency, or the gas supplier.

WARNING: Before performing recommended maintenance, be sure main power switch to unit is turned off. Electrical shock could cause serious injury or death.

Your rooftop combination heating/cooling unit is equipped with an automatic direct-spark ignition and induced-draft combustion blower.

WARNING: Do not attempt to light by hand; serious injury or death may result.

TO LIGHT UNIT

WARNING:

1. Do not attempt to light by hand; personal injury may result.
2. Before attempting to start the gas heating section, familiarize yourself with all the procedures that must be followed.

If you do not follow these instructions exactly, a fire or explosion may result. Property damage, injury, or loss of life could occur.

See Fig. 1 for location of gas valve. Refer to Fig. 2 while proceeding through the following steps.

I. Step 1

Set room thermostat to the lowest temperature setting and set SYSTEM switch to HEAT or AUTO. position.

II. Step 2

Close the manual gas valve.

III. Step 3

Turn off the electrical supply to the unit and install lockout tag.

IV. Step 4

Remove the burner access panel.

V. Step 5

Move the control on the gas valve to the OFF position and wait 5 minutes.

VI. Step 6

Move control on gas valve to ON position.

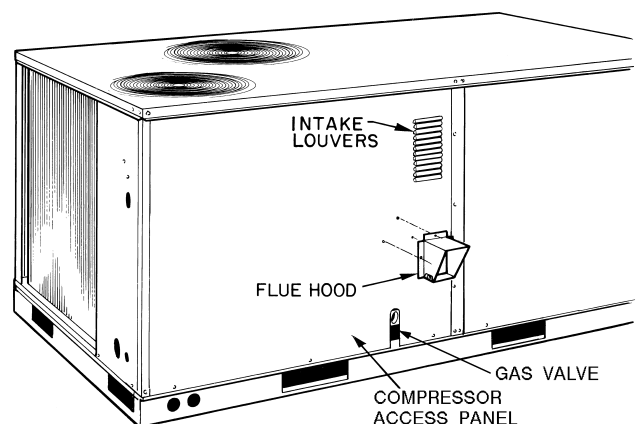
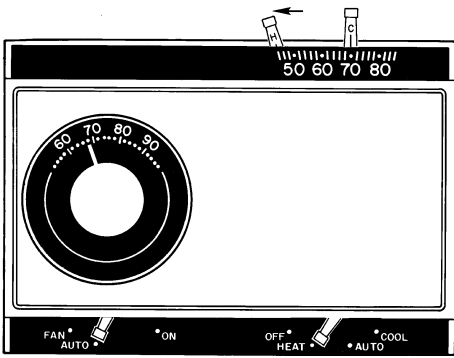
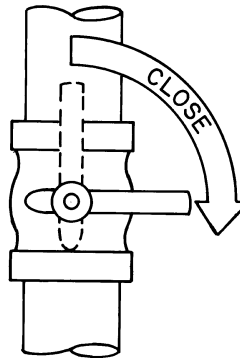

Fig. 1 — Typical Gas Valve Location
(581B090 Shown)



STEP 1



STEP 2

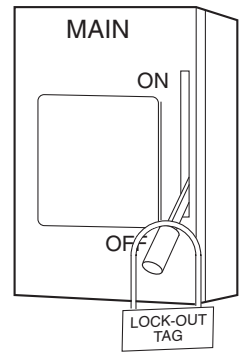

STEP 3

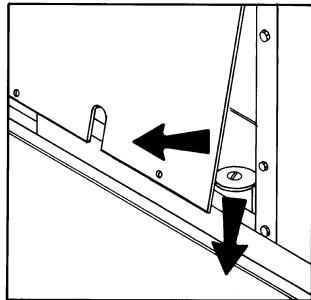
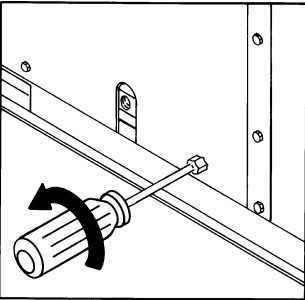

STEP 4

TWO-STAGE GAS VALVE

SINGLE-STAGE VALVE

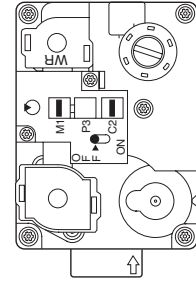
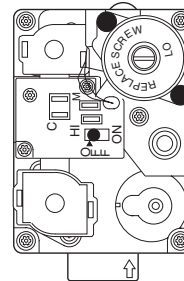

- 3-Phase Models
 581B036-072072
 581B036-072115
 581B048-072150
 581B090-102125
 581B090-120180
 581B090-150224
 581B120-150250

- California Compliant 3-Phase
 581B036-060071
 581B036-060114
 581B048,060149
 Single Phase
 581B036-060072
 581B036-060115
 581B048,060150
 Low NO_x
 581B036-060060N
 581B036-060090N
 581B048,060120N

TWO-STAGE GAS VALVE

SINGLE-STAGE VALVE

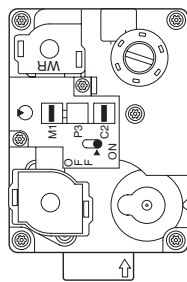
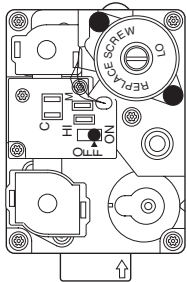

- 3-Phase Models
 581B036-072072
 581B036-072115
 581B048-072150
 581B090-102125
 581B090-120180
 581B090-150224
 581B120-150250

- California Compliant 3-Phase
 581B036-060071
 581B036-060114
 581B048,060149
 Single Phase
 581B036-060072
 581B036-060115
 581B048,060150
 Low NO_x
 581B036-060060N
 581B036-060090N
 581B048,060120N

STEP 5

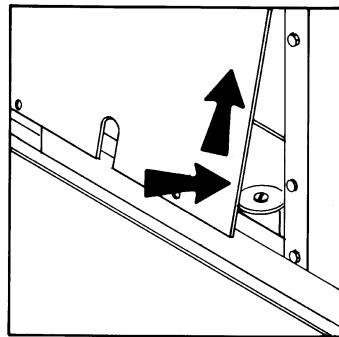

STEP 6

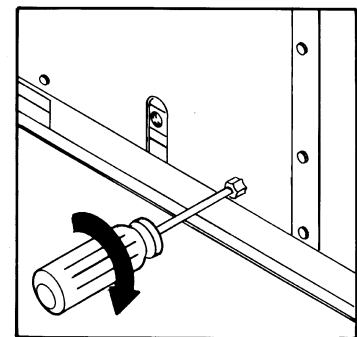

STEP 7

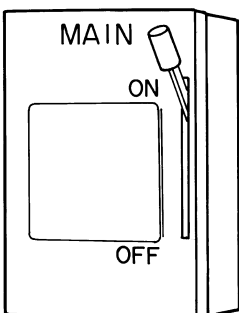

STEP 8

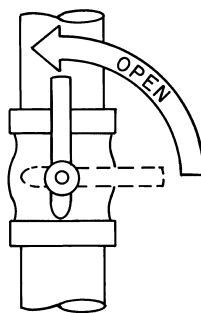

STEP 9

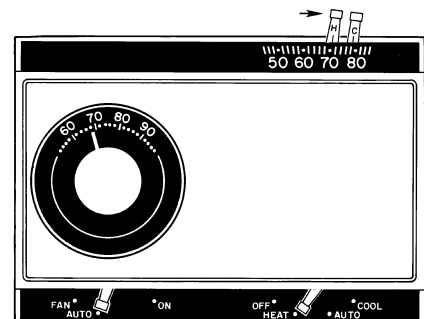

STEP 10

Fig. 2 — To Light Unit

VII. Step 7

Replace the burner access panel.

VIII. Step 8

Turn on the electrical supply to unit.

IX. Step 9

Open the manual gas valve.

X. Step 10

Set room thermostat selector slightly above room temperature to start unit. The induced-draft combustion air fan will start. Main gas valve will open and main burners should ignite within 5 seconds. If the burners do not light, there is a 22-second delay before another 5-second try. If the burner still does not light, the time delay is repeated. If the burner does not light within 15 minutes, there is a lockout. If burners still do not light, call for service.

⚠ WARNING: If the main burners fail to light, or the blower fails to start, shut down gas heating section and call your dealer for service. Failure to follow these requirements could result in serious injury or death.

XI. Step 11

Set the temperature selector on the room thermostat to desired setting.

TO SHUT UNIT OFF

⚠ WARNING:

1. Do not turn off the electrical power to unit without first turning off the gas supply.
2. Never attempt to manually light the main burners on unit with a match, lighter, or any other flame. If the electric sparking device fails to light the main burners, refer to the following shutdown procedures. Call your dealer as soon as possible.

Failure to follow these procedures could result in serious fire or serious injury or death.

Refer to Fig. 3 while proceeding with the following steps:

I. Step 1

Set room thermostat to lowest temperature setting and set SYSTEM switch to OFF position.

II. Step 2

Close the external manual gas valve.

III. Step 3

Turn off the electrical power supply to unit and install lock-out tag.

IV. Step 4

Remove the burner access panel.

V. Step 5

Move the control on the gas valve to the OFF position.

VI. Step 6

Replace the burner access panel.

VII. Step 7

If unit is being shut down because of a malfunction, call your dealer as soon as possible.

If unit is being shut down because the heating season has ended, restore electrical power to the unit to ensure operation of the cooling system during the cooling season.

Should overheating occur, or the gas supply fail to shut off, shut off the manual gas valve to the unit before shutting off the electrical supply.

Do not use this unit if any part has been under water. Immediately call a qualified service technician to inspect the unit and to replace any part of the control system and any gas control which has been under water.

MAINTAINING YOUR UNIT

All maintenance should be handled by skilled, experienced personnel. Your dealer can help you establish a standard procedure.

For your safety, keep the unit area clear and free of combustible materials, gasoline, and other flammable liquids and vapors.

To ensure proper functioning of the unit, flow of combustion and ventilating air must not be prevented from reaching the unit.

To ensure proper airflow, clearance to the condenser coil should be 36 in. on one side and 12 in. on the other. Either side may receive the greater clearance. A clearance of 1 in. from the bottom of the unit to combustible surfaces must be maintained when not using a roof curb. A clearance of 0 in. from the bottom of the base rail to combustible surfaces must be maintained when not using a roof curb. A 60-in. clearance above the unit must be allowed for proper condenser fan operation.

A clearance of 42 in. should be allowed on the unit control box side. When ungrounded surfaces are present, allow a 36-in. clearance between unit and the ungrounded surfaces. Allow 42 in. between the unit and block or concrete walls or other grounded surfaces.

Clearance of 48 in. must be maintained between flue side and combustible surfaces.

ROUTINE MAINTENANCE AND CARE FOR THE EQUIPMENT OWNER

Consider the following information before maintaining or servicing equipment:

⚠ WARNING:

1. TURN OFF GAS SUPPLY AND THEN ELECTRICAL POWER TO YOUR UNIT BEFORE SERVICING OR PERFORMING MAINTENANCE.
2. DO NOT turn off electrical power to this unit without first turning off the gas supply.
3. When removing access panels or performing maintenance functions inside your unit, be aware of sharp sheet metal parts and screws. Although special care has been taken to reduce sharp edges to a minimum, be extremely careful when handling parts or reaching into the unit.

Failure to follow these instructions could result in serious fire or serious injury or death.

I. AIR FILTERS

Air filter(s) should be checked at least every 3 or 4 weeks and changed or cleaned when necessary. Table 1 indicates the correct filter size for your unit. See Fig. 4 for filter access door location.

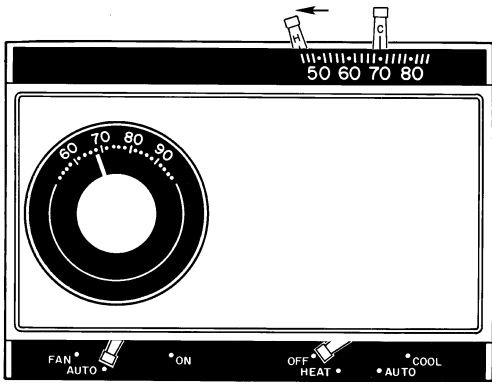

STEP 1

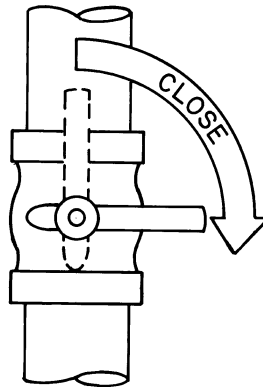

STEP 2

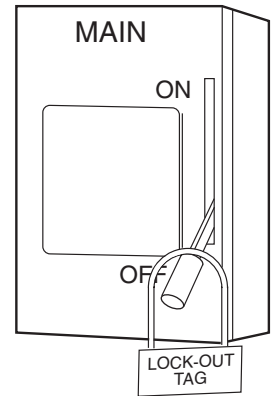

STEP 3

TWO-STAGE GAS VALVE

SINGLE-STAGE VALVE

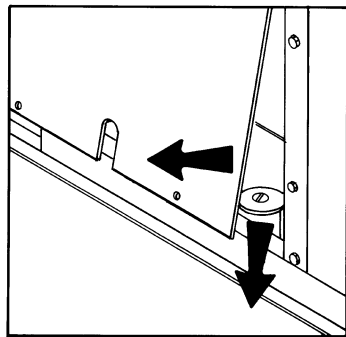
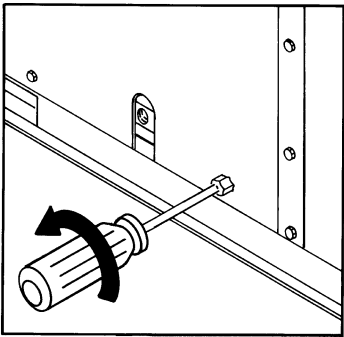

STEP 4

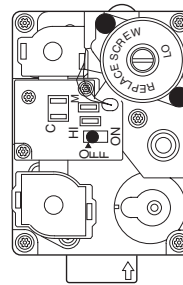

- 3-Phase Models
 581B036-072072
 581B036-072115
 581B048-072150
 581B090-102125
 581B090-120180
 581B090-150224
 581B120-150250

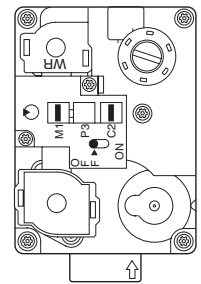

- California Compliant 3-Phase
 581B036-060071
 581B036-060114
 581B048,060149
 Single Phase
 581B036-060072
 581B036-060115
 581B048,060150
 Low NO_x
 581B036-060060N
 581B036-060090N
 581B048,060120N

STEP 5

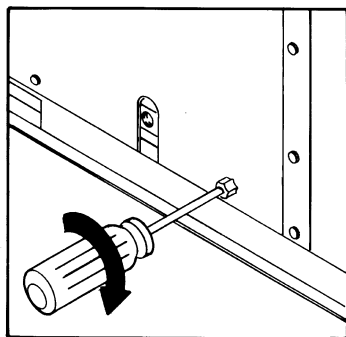
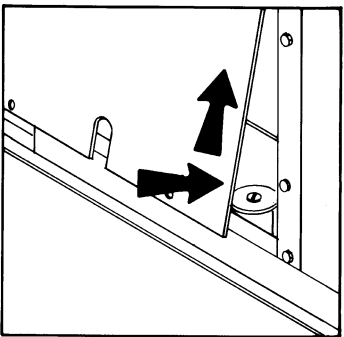

STEP 6

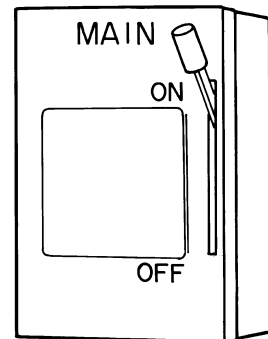

STEP 7

Fig. 3 — To Shut Unit Off

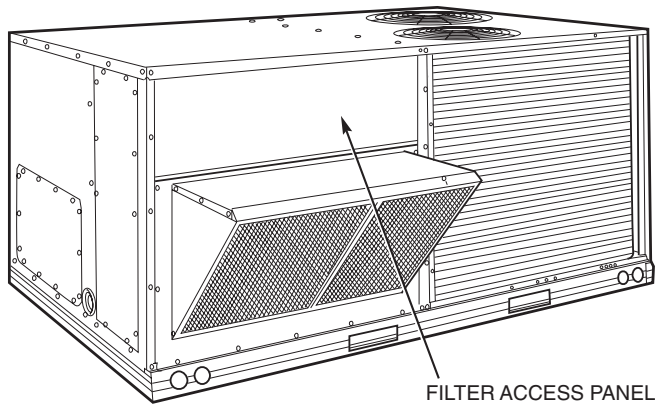

Fig. 4 — Typical Filter Access Panel Location (581B090 Shown)

To replace or inspect filters:

1. Lift up and remove filter access panel.
2. While holding filter, tilt upper filter track.
3. Remove filters by pulling up and out toward you from the track.
4. Inspect or replace filters.
5. Place filters back in the filter tracks. When installing filters, note the direction of airflow arrows on the filter frame.
6. Reinstall filter access panel.

If you have difficulty locating your air filter or if you have questions concerning proper filter maintenance, contact your dealer for additional instructions. When replacing your unit's filters, always use the same size and type of filter that was originally supplied by the installer.

Units with outdoor air capability have a cleanable filter for the outdoor air. This filter should be checked annually and cleaned as necessary with steam or hot water and a mild detergent. Do not use throwaway filters in place of cleanable filters.

⚠ WARNING: Never operate your unit without filters in place. Failure to heed this warning may result in damage to the blower motor and/or compressor. An accumulation of dust and lint on internal parts of your unit can cause loss of efficiency and, in some cases, fire that could result in serious injury or death.

Table 1 — Indoor-Air Filter Data

UNIT SIZE 581B	INDOOR AIR FILTERS (Throwaway Fiberglass)	
	Quantity	Size (in.)
036-072	2	16 x 25 x 2
090,102	4	16 x 20 x 2
120,150	4	20 x 20 x 2

NOTE: See unit Installation Instructions if optional filters are used. When replacing filters, always use the same type and size originally supplied.

II. HEAT EXCHANGER

To ensure dependable and efficient heating operation, the heat exchanger should be checked by a qualified maintenance

person before each heating season and cleaned when necessary. This checkout should not be attempted by anyone who does not have the required licensing, expertise and/or equipment to do the job properly. Checking and/or cleaning the heat exchanger involves removing the gas controls assembly and the flue collector box cover. When finished, the gas controls assembly must be reinstalled for proper operation. Also, the flue collector box cover must be replaced correctly so that a proper seal is maintained. Contact your dealer for the required periodic maintenance.

III. FANS, BELTS, AND FAN MOTOR

At the beginning of each heating and cooling season, check the condition of fan wheels and housings, belt tension, and fan motor shaft bearings. No lubrication of condenser or evaporator fan bearings or motors is required or recommended.

IV. EVAPORATOR AND CONDENSER COILS

Inspect and clean the condenser and evaporator coils at the beginning of each cooling season, or more frequently as conditions require.

Cleaning of the coils should only be done by qualified service personnel. Contact your dealer for the required annual maintenance.

V. CONDENSATE DRAIN

The drain pan, condensate trap, and drain line should be checked and cleaned at the same time the cooling coils are checked by your dealer.

VI. COMPRESSOR

All compressors are factory-supplied with a normal charge of the correct type of refrigeration-grade oil and should not require additional oil.

VII. CONDENSER FAN

⚠ WARNING: Do not poke sticks, screwdrivers, or any other object into revolving fan blades. Severe bodily injury could result.

The fan must be kept free of all obstructions to ensure proper cooling. Contact your dealer for any required service.

VIII. ELECTRICAL CONTROLS AND WIRING

Electrical controls are difficult to check without proper instrumentation. If there are any discrepancies in the operating cycle, contact your dealer and request service.

IX. REFRIGERANT CIRCUIT

The refrigerant circuit is difficult to check for leaks without the proper equipment. If inadequate cooling is suspected, contact your dealer for service.

X. COMBUSTION AREA AND VENT SYSTEM

The combustion area and vent system should be visually inspected before each heating season. The normal accumulation of dirt, soot, rust, and scale can result in loss of efficiency and improper performance if allowed to build up.

⚠ CAUTION: If your unit makes unusual or especially loud noises during heating, shut down the heating section and call your qualified Bryant dealer.

See Fig. 1 and 5 and proceed as follows to inspect the combustion area and venting system of your unit.

1. Turn off gas supply to your unit.
2. Turn off electrical power to your unit. Install lockout tag on disconnect.
3. Remove compressor and burner access panels.
4. Using a flashlight, carefully inspect the burner areas for dirt, soot, rust, or scale.

CAUTION: If dirt, soot, rust, or scale accumulations are found, call your dealer and do not operate your heating section.

5. When you have completed your inspection, follow the start-up procedures in this manual to restore your unit to operation.
6. Observe unit heating operation.

WARNING: Components in heating section may be hot after unit has been started. When observing flame, be careful not to get close to or touch heating components. Serious personal injury could result.

Watch the burner flame to see if it is bright blue. If you observe a suspected malfunction or that the burner flame is not bright blue, call your dealer.

7. Turn off unit gas supply and electrical power.
8. Replace compressor and burner access panels.

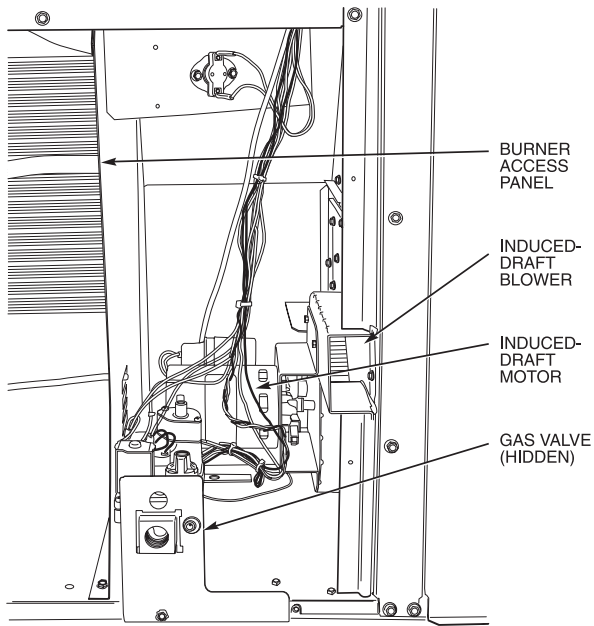

Fig. 5 — Typical Heat Section Detail

XI. UNIT PANELS

After performing any maintenance or service on the unit, be sure all panels are securely fastened in place to prevent rain from entering unit cabinet and to prevent disruption of the correct unit airflow pattern.

REGULAR DEALER MAINTENANCE

In addition to the type of routine maintenance you might be willing to perform, your unit should be inspected regularly by a properly trained and qualified service technician. An inspection (preferably each year, but at least every other year) should include the following:

1. Inspection of all flue product passages — including the burners, heat exchanger, and flue collector box.
2. Inspection of all combustion- and ventilation-air passages and openings.
3. Close inspection of all gas pipes leading to and inside your unit.
4. Inspection, and if required, cleaning of the condenser and evaporator coils.
5. Inspection and, if required, cleaning of the condensate drain pan and trap.
6. Inspection and cleaning of blower wheel housing and motor.
7. Inspection of all supply- and return-air ducts for leaks, obstructions, and insulation integrity. Any problems found should be resolved at time of inspection.
8. Inspection of the unit base for cracks, gaps, etc., which may cause a hazardous condition.
9. Inspection of the unit casing for signs of deterioration.
10. Inspection of all electrical wiring and components to ensure proper connection.
11. Inspection for leaks in the refrigerant circuit. Pressure-check to determine appropriate refrigerant charge.
12. Inspection and cleaning of fan wheels and housings, belt tension, and fan motor and shaft bearings.
13. Operational check of the unit to determine working conditions. Repair or adjustment should be made at the time of inspection.

Your servicing dealer may offer an economical service contract that covers seasonal inspections. Ask for further details.

Complete service instructions can be found in the base unit Installation, Start-Up and Service Instructions.

BEFORE YOU CALL FOR SERVICE, CHECK FOR SEVERAL PROBLEMS THAT CAN BE EASILY SOLVED

If insufficient heating or cooling is suspected:

() Check for sufficient airflow. Check the air filter for dirt. Check for blocked return- or supply-air grilles. Be sure they are open and unobstructed. If these checks do not reveal the cause, call your servicing dealer.

If your unit is not operating at all, check the following list for easy solutions:

() Check to be sure that your thermostat temperature selector is set above the indoor temperature during the heating season, or below the indoor temperature during the cooling season. Be sure the SYSTEM switch is in the proper HEAT, COOL, or AUTO. position and not in the OFF position.

() Is the electrical supply switch ON? Are any fuses blown or has the circuit breaker tripped?

() During the heating season, check the external manual shutoff valve. Is this lever parallel with the pipe, indicating that the valve is open? Or is the lever at a right angle, indicating that the valve is closed? If closed, has the gas been shut off for safety reasons? Otherwise, you may open the valve and follow the start-up procedures listed in this manual.

NOTE: Before proceeding with the next check, shut OFF the gas supply to the unit and then turn OFF the electrical

power supply to the unit. Remove the compressor access panel.

() During the heating season, check the control switch on the gas valve. Is it in the ON position? If it is not, be sure it has not been turned off as a safety precaution. If no safety hazards are present, follow the start-up procedures in this manual.

() If your unit still fails to operate, call your servicing dealer for troubleshooting and repairs. Specify the model and serial numbers of your unit. (Record them in this manual in the space provided.) If the dealer knows exactly which unit you have, he may be able to offer suggestions over the phone, or save valuable time through knowledgeable preparation for the service call.

IN CASE OF TROUBLE

If after performing the above routine checks, unit performance is unsatisfactory, shut off the unit and call your dealer.

Dealer's Name _____

Telephone _____

Unit Model _____

Unit Serial Number _____



Bryant Heating & Cooling Systems

FOR SERVICE OR REPAIR, FOLLOW THESE STEPS IN ORDER:

- FIRST:** Contact the installer. You may find his name on the product or in your Homeowner's Packet. If the installer's name is not known, call your builder if yours is a new residence.
- SECOND:** Contact the nearest distributor. (See telephone yellow pages.)
- THIRD:** Contact:
 BRYANT HEATING & COOLING SYSTEMS
 Consumer Relations Department
 P.O. Box 4808
 Syracuse, New York 13221
 Phone: 1-800-428-4326

Model No. _____ Unit Serial No. _____

Date of Installation _____ Installed by _____

Name of Owner _____ Address of Installation _____

Outdoor Cooling or Heating-Cooling Product (Units Smaller Than 185,000-Btuh Cooling Capacity) Limited Warranty

ONE-YEAR LIMITED WARRANTY — Bryant Heating & Cooling Systems (hereinafter referred to as "Company") warrants this product to be free from defects in material and workmanship. If a defect is found within one year from date of original installation of product (whether or not actual use begins on that date) Company will provide a new or remanufactured part, at Company's sole option, to replace any defective part, without charge for the part itself.

TEN-YEAR LIMITED WARRANTY ON HEAT EXCHANGER ONLY — If a defect is found in the heat exchanger within ten years from the date of original installation of product, Company will either provide a new or remanufactured heat exchanger, without charge for the part itself, or at Company's option, allow a credit in the amount of the then factory selling price for a new equivalent heat exchanger toward the retail purchase price of a new Bryant unit.

FIVE-YEAR LIMITED WARRANTY ON COMPRESSOR ONLY — If a defect is found in the compressor within five years from the date of original installation of product, Company will provide a new or remanufactured compressor, at the Company's sole option, to replace any defective compressor, without charge for the part itself.

FIVE-YEAR LIMITED WARRANTY ON ELECTRICAL ELEMENT FOR AIR HEATING ONLY — If a defect is found in any electrical element within five years from the date of original installation of product, Company will provide a new or remanufactured electrical element, at the Company's sole option, to replace defective electrical element, without charge for the part itself.

None of these warranties include labor or other costs incurred for diagnosing, repairing, removing, installing, shipping, servicing or handling of either defective parts, or replacement parts, or new units.

WARRANTY CONDITIONS:

1. Warranties apply only to products in their original installation location.
2. Installation, use, care, and maintenance must be normal and in accordance with instructions contained in the Owner's Manual and Company's service information.
3. Defective parts must be returned to the distributor through a registered servicing dealer for credit.

4. All work shall be performed during normal working hours.

LIMITATION OF WARRANTIES — ALL IMPLIED WARRANTIES (INCLUDING IMPLIED WARRANTIES OF MERCHANTABILITY AND FITNESS FOR A PARTICULAR PURPOSE) ARE HEREBY LIMITED IN DURATION TO ONE YEAR. SOME STATES DO NOT ALLOW LIMITATIONS ON HOW LONG AN IMPLIED WARRANTY LASTS, SO THE ABOVE MAY NOT APPLY TO YOU. THE EXPRESS WARRANTIES ARE EXCLUSIVE AND MAY NOT BE ALTERED, ENLARGED, OR CHANGED BY ANY DISTRIBUTOR, DEALER, OR OTHER PERSON WHATSOEVER.

COMPANY WILL NOT BE RESPONSIBLE FOR:

1. Normal maintenance as outlined in the installation and servicing instructions or Owner's Manual, including filter cleaning and/or replacement and lubrication.
2. Damage or repairs required as a consequence of faulty installation, misapplication, abuse, improper servicing, unauthorized alteration or improper operation.
3. Failure to start due to voltage conditions, blown fuses, open circuit breakers, or damages due to the inadequacy or interruption of electrical service.
4. Damage as a result of floods, winds, fires, lightning, accidents, corrosive environments or other conditions beyond the control of Company.
5. Parts not supplied or designated by Company, or damages resulting from their use.
6. Company products installed outside the continental U.S.A., Alaska, Hawaii, and Canada.
7. Electricity or fuel costs, or increases in electricity or fuel costs from any reason whatsoever, including additional or unusual use of supplemental electric heat.
8. ANY SPECIAL INDIRECT OR CONSEQUENTIAL PROPERTY OR COMMERCIAL DAMAGE OF ANY NATURE WHATSOEVER. Some states do not allow the exclusion of incidental or consequential damages, so the above limitation may not apply to you.

This Warranty gives you specific legal rights, and you may also have other rights which vary from state to state.

Catalog No. 5358-110

Effective on product manufactured after July 1, 1987. Supersedes any other warranty certificates supplied with the product.

39004DP247