

Makita

Curved Planer

82 mm (3-1/4") MODEL 1001

INSTRUCTION MANUAL

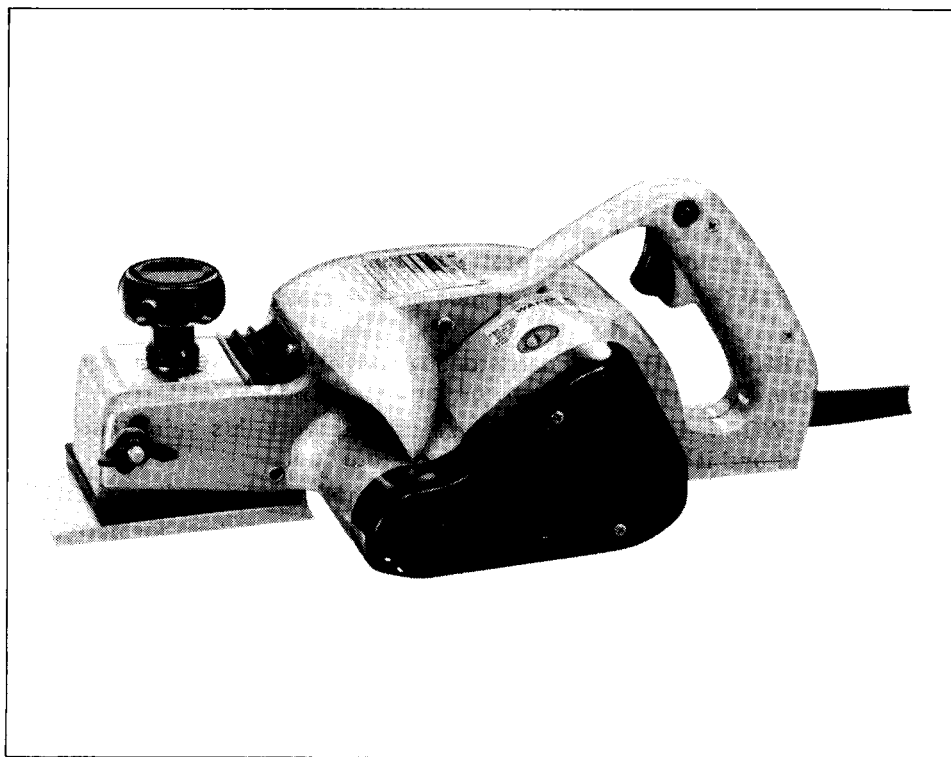

SPECIFICATIONS

Planing width	Planing depth	No load speed (RPM)	Overall length	Net weight
82 mm (3-1/4")	3 mm (1/8")	12,000	370 mm (14-1/2")	6.0 kg (13.2 lbs)

- Manufacturer reserves the right to change specifications without notice.
- Note: Specifications may differ from country to country.

IMPORTANT SAFETY INSTRUCTIONS

WARNING: When using *electric tools*, *basic safety precautions* should always be followed to reduce the risk of fire, electric shock, and personal injury, including the following:

READ ALL INSTRUCTIONS.

1. **KEEP WORK AREA CLEAN.** Cluttered areas and benches invite injuries.
2. **CONSIDER WORK AREA ENVIRONMENT.** Don't use power tools in damp or wet locations. Keep work area well lit. Don't expose power tools to rain. Don't use tool in presence of flammable liquids or gases.
3. **KEEP CHILDREN AWAY.** All visitors should be kept away from work area. Don't let visitors contact tool or extension cord.
4. **STORE IDLE TOOLS.** When not in use, tools should be stored in dry, and high or locked-up place — out of reach of children.
5. **DON'T FORCE TOOL.** It will do the job better and safer at the rate for which it was intended.
6. **USE RIGHT TOOL.** Don't force small tool or attachment to do the job of a heavy-duty tool. Don't use tool for purpose not intended.
7. **DRESS PROPERLY.** Don't wear loose clothing or jewelry. They can be caught in moving parts. Rubber gloves and non-skid footwear are recommended when working outdoors. Wear protective hair covering to contain long hair.
8. **USE SAFETY GLASSES.** Also use face or dust mask if cutting operation is dusty.
9. **DON'T ABUSE CORD.** Never carry tool by cord or yank it to disconnect from receptacle. Keep cord from heat, oil, and sharp edges.
10. **SECURE WORK.** Use clamps or a vise to hold work. It's safer than using your hand and it frees both hands to operate tool.
11. **DON'T OVERREACH.** Keep proper footing and balance at all times.
12. **MAINTAIN TOOLS WITH CARE.** Keep tools sharp and clean for better and safer performance. Follow instructions for lubricating and changing accessories. Inspect tool cords periodically and if damaged, have repaired by authorized service facility. Inspect extension cords periodically and replace if damaged. Keep handles dry, clean, and free from oil and grease.
13. **DISCONNECT TOOLS.** When not in use, before servicing, and when changing accessories, such as blades, bits, cutters.
14. **REMOVE ADJUSTING KEYS AND WRENCHES.** Form habit of checking to see that keys and adjusting wrenches are removed from tool before turning it on.
15. **AVOID UNINTENTIONAL STARTING.** Don't carry plugged-in tool with finger on switch. Be sure switch is OFF when plugging in.
16. **OUTDOOR USE EXTENSION CORDS.** When tool is used outdoors, use only extension cords intended for use outdoors and so marked.

17. **STAY ALERT.** Watch what you are doing, use common sense. Don't operate tool when you are tired.
18. **CHECK DAMAGED PARTS.** Before further use of the tool, a guard or other part that is damaged should be carefully checked to determine that it will operate properly and perform its intended function. Check for alignment of moving parts, binding of moving parts, breakage of parts, mounting, and any other conditions that may affect its operation. A guard or other part that is damaged should be properly repaired or replaced by an authorized service center unless otherwise indicated elsewhere in this instruction manual. Have defective switches replaced by authorized service center. Don't use tool if switch does not turn it on and off.
19. **GUARD AGAINST ELECTRIC SHOCK.** Prevent body contact with grounded surfaces. For example; pipes, radiators, ranges, refrigerator enclosures.
20. **PROPER GROUNDING.** This tool should be grounded while in use to protect the operator from electric shock.
21. **EXTENSION CORDS:** Use only three-wire extension cords which have three-prong grounding-type plugs and three-pole receptacles which accept the tool's plug. Replace or repair damaged or worn cord immediately.

VOLTAGE WARNING: Before connecting the tool to a power source (receptacle, outlet, etc.) be sure the voltage supplied is the same as that specified on the nameplate of the tool. A power source with voltage greater than that specified for the tool can result in **SERIOUS INJURY** to the user — as well as damage to the tool. If in doubt, **DO NOT PLUG IN THE TOOL.** Using a power source with voltage less than the nameplate rating is harmful to the motor.

ADDITIONAL SAFETY RULES

1. Rags, cloth, cord, string and the like should never be left around the work area.
2. Avoid cutting nails. Inspect for and remove all nails from the workpiece before operation.
3. Handle the blades very carefully.
4. Be sure the blade installation bolts are securely tightened before operation.
5. Hold the tool firmly with both hands.
6. Keep hands away from rotating parts.
7. Before using the tool on an actual workpiece, let it run for a while. Watch for vibration or wobbling that could indicate poor installation or a poorly balanced blade.
8. Make sure the blade is not contacting the workpiece before the switch is turned on.
9. Wait until the blade attains full speed before cutting.
10. Keep at least 200 mm (8'') away from the tool at all times.
11. Always switch off and wait for the blades to come to a complete stop before any adjusting.
12. Never stick your finger into the chip chute. Chute may jam when cutting damp wood. Clean out chips with a stick.
13. Do not leave the tool running. Operate the tool only when hand-held.
14. When leaving the planer, switch off and set it with the front base up on a wooden block, so that the blades do not contact anything.
15. Always change both blades or covers on the drum, otherwise the resulting imbalance will cause vibration and shorten tool life.

SAVE THESE INSTRUCTIONS.

Removing or installing planer blades

WARNING:

Always be sure that the tool is switched off and unplugged before removing or installing the blades.

To remove the blades on the drum, unscrew the three installation bolts with the socket wrench. The drum cover comes off together with the blades.

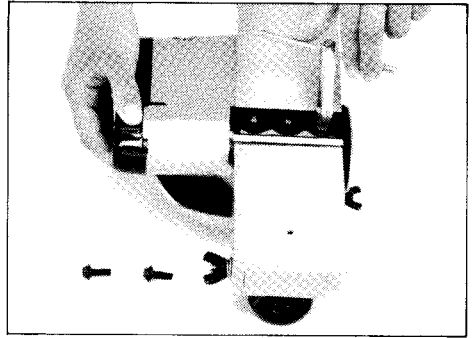

To install the blades, first clean out all chips or foreign matter adhering to the drum or blades. Use blades of the same dimensions and weight, or drum oscillation/vibration will result, causing poor planing action and, eventually, tool breakdown.

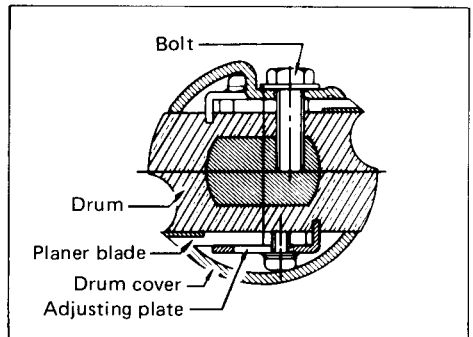

Place the blade on the gauge base so that the blade edge is perfectly flush with the inside edge of the gauge plate. Place the adjusting plate on the blade, then simply press in the heel of the adjusting plate flush with the back side of the gauge base and tighten the two screws on the adjusting plate. Now slip the heel of the adjusting plate into the drum groove, then fit the drum cover on it. Tighten the three installation bolts evenly and alternately with the socket wrench.

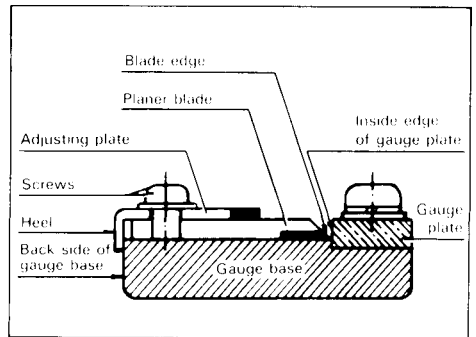

WARNING:

Tighten the blade installation bolts carefully when attaching the blades to the tool. A loose installation bolt can be dangerous. Always check to see they are tightened securely.

Adjusting depth of cut

Depth of cut may be adjusted by simply turning the knob on the front of the tool.

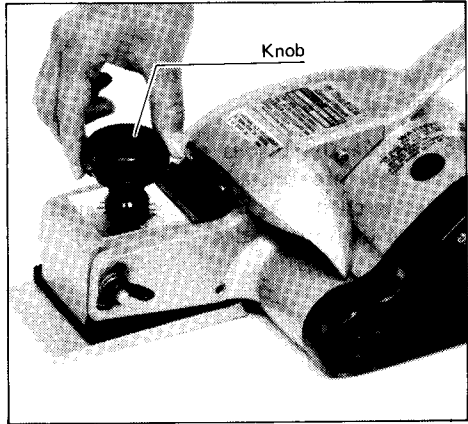

Adjusting front base

1. To create a curved surface, loosen the wing nut. For a concave planing job, raise the front base; for a convex planing job, lower the front base. In either case, the front base must be aligned with the cutting line. Then tighten the wing nut securely.

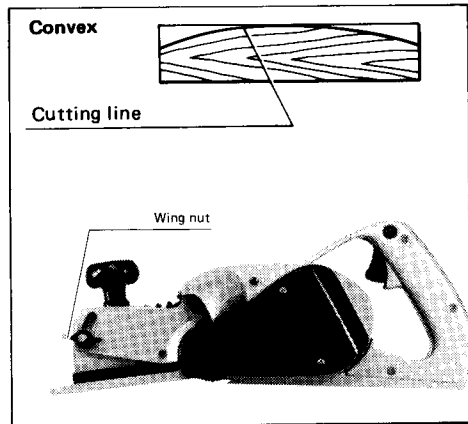

NOTE:

As explained later, although the objective is to cut until the cutting line is eventually reached, the planing must take place gradually.

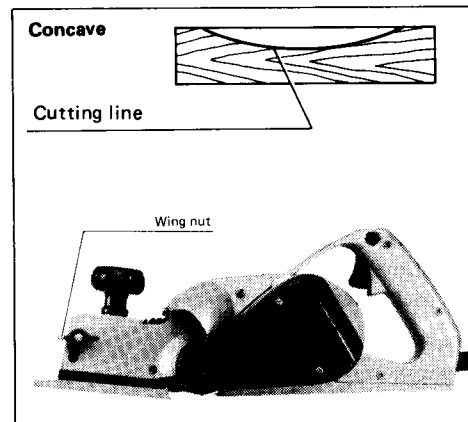

2. To create a flat surface, loosen the wing nut after setting the tool on a level surface. Turn the front knob on the tool until the front base is perfectly level with the rear base. Then tighten the wing nut securely.

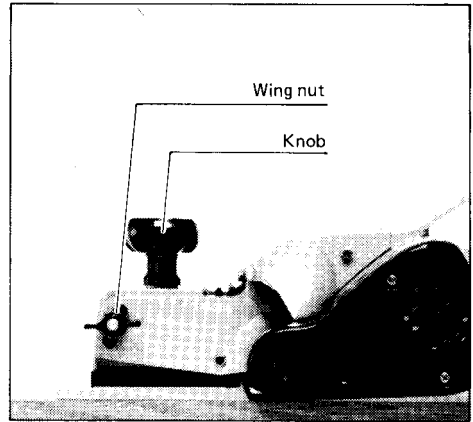

Switch action

To start the tool, simply pull the trigger. Release the trigger to stop. For continuous operation, pull the trigger and then push in the lock button. To stop the tool from the locked position, pull the trigger fully, then release it.

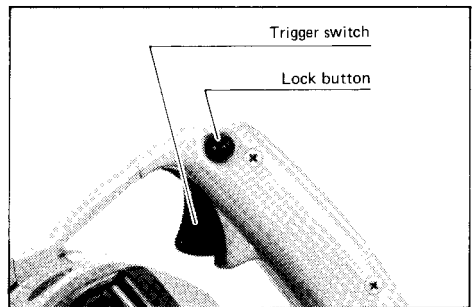

WARNING:

Before plugging in the tool, always check to see that the trigger switch actuates properly and returns to the "OFF" position when released.

Planing operation

First, rest the tool front base flat upon the workpiece surface without the blades making any contact. Switch on and wait until the blades attain full speed. Then move the tool gently forward. Apply pressure on the front of tool at the start of planing, and at the back at the end of planing. The speed and depth of cut determine the kind of finish. The power planer keeps cutting at a speed that will not result in jamming by chips. For rough cutting, the depth of cut can be increased, while for a good finish you should reduce the depth of cut and advance the tool more slowly.

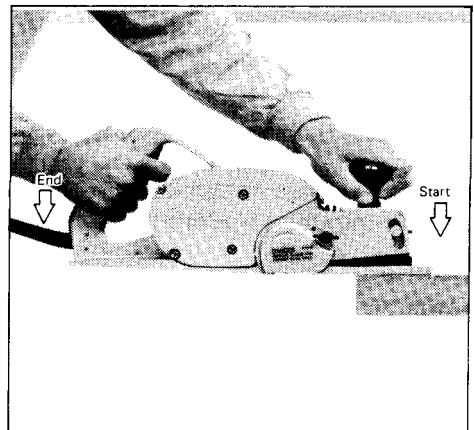

NOTE:

- When beginning the planing of a flat workpiece to obtain eventually a convex shape, first take down both ends of the workpiece, gradually planing until the ultimate convex shape is achieved.

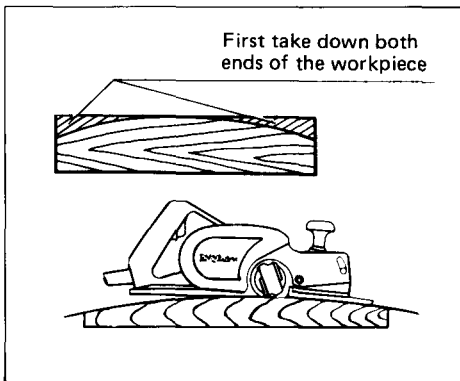

- When beginning the planing of a flat workpiece to obtain eventually a concave shape, first take down the middle of the workpiece, gradually planing until the ultimate concave shape is achieved.

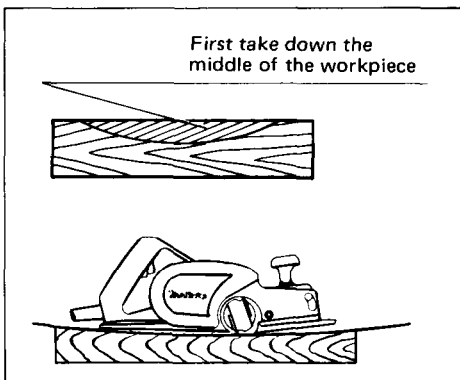

Shiplapping or corner cuts (flush cuts)

When performing the shiplapping or corner cuts (flush cuts up against a wall), remove the wing bolt to take off the drum cover, allowing flush-side work.

NOTE:

Corner cuts (flush cuts up against a wall) are impossible, of course, if the tool cannot be moved forward or backward because of a wall or something blocking the tool path.

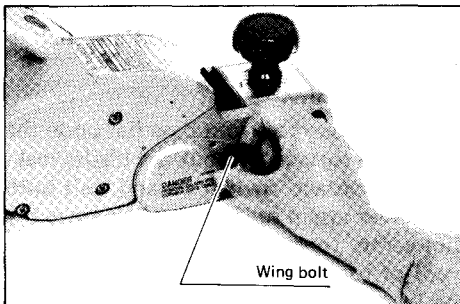

WARNING:

- With the drum cover removed for corner cuts (flush cuts) or shiplapping, be very careful not to touch the drum/blades or allow your clothing to be caught during operation.
- After performing the shiplapping or corner cuts (flush cuts), ALWAYS RE-INSTALL THE DRUM COVER AND TIGHTEN THE WING BOLT SECURELY. Never forget to switch off and unplug the tool, and wait for the blades to come to a complete stop before re-installing the drum cover.

Sharpening planer blades

Always keep your blades sharp for the best performance possible. Use the sharpening holder to remove nicks and produce a fine edge.

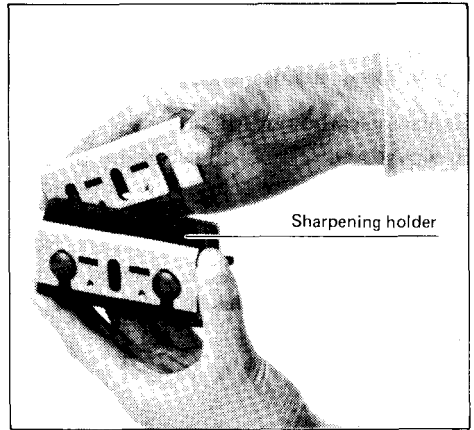

First, loosen the two wing nuts on the holder and insert the blades (A) and (B), so that they contact the sides (C) and (D). Then tighten the wing nuts.

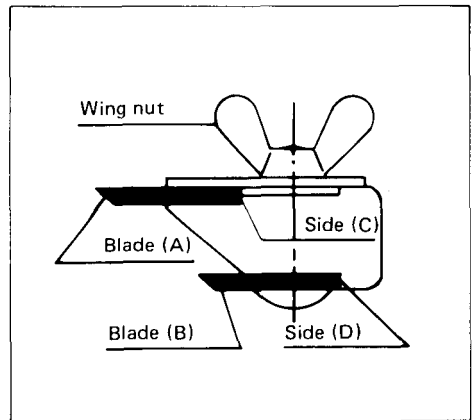

Immerse the dressing stone in water for 2 or 3 minutes before sharpening. Hold the holder so that the blades both contact the dressing stone for simultaneous sharpening at the same angle.

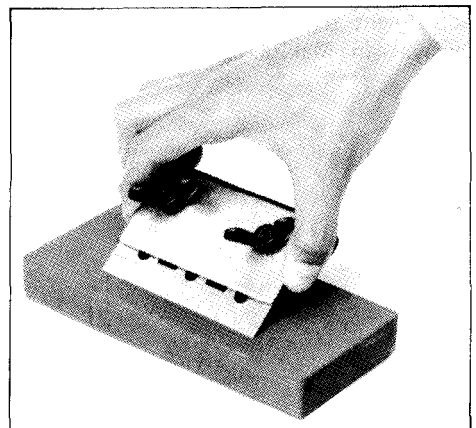

MAINTENANCE

CAUTION:

Always be sure that the tool is switched off and unplugged before attempting to perform inspection or maintenance.

Replacing carbon brushes

Remove and check the carbon brushes regularly. Replace when they wear down to the limit mark. Keep the carbon brushes clean and free to slip in the holders. Both carbon brushes should be replaced at the same time. Use only Makita carbon brushes.

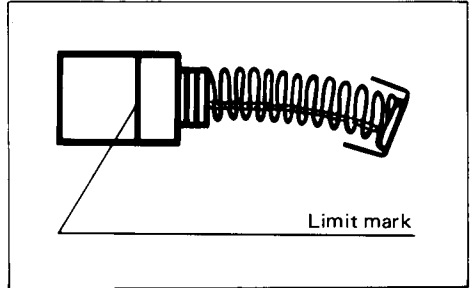

Use a screwdriver to remove the brush holder caps. Take out the worn carbon brushes, insert the new ones and secure the brush holder caps.

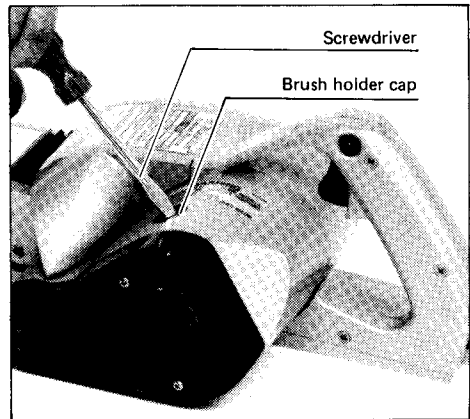

To maintain product SAFETY and RELIABILITY, repairs, any other maintenance or adjustment should be performed by Makita Authorized or Factory Service Centers, always using Makita replacement parts.

ACCESSORIES

CAUTION:

These accessories or attachments are recommended for use with your Makita tool specified in this manual. The use of any other accessories or attachments might present a risk of injury to persons. The accessories or attachments should be used only in the proper and intended manner.

- **Planer blade**

Width: 82 mm (3-1/4")
Part No. 793004-6



- **Planer blade**

(Material: Tungsten-carbide)
Width: 82 mm (3-1/4")
Part No. 793007-0



- **Sharpening holder assembly**

Part No. 123004-6

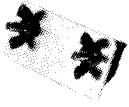

- **Blade gauge assembly**

Part No. 123062-2

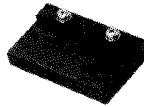

- **Socket wrench**

Part No. 782209-3

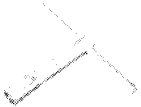

- **Dressing stone**

Part No. 794061-7



- **Screwdriver**

Part No. 783002-8



- **Steel carrying case**

Part No. 181840-6



82 mm (3-1/4") CURVED PLANER Model 1001

Type1

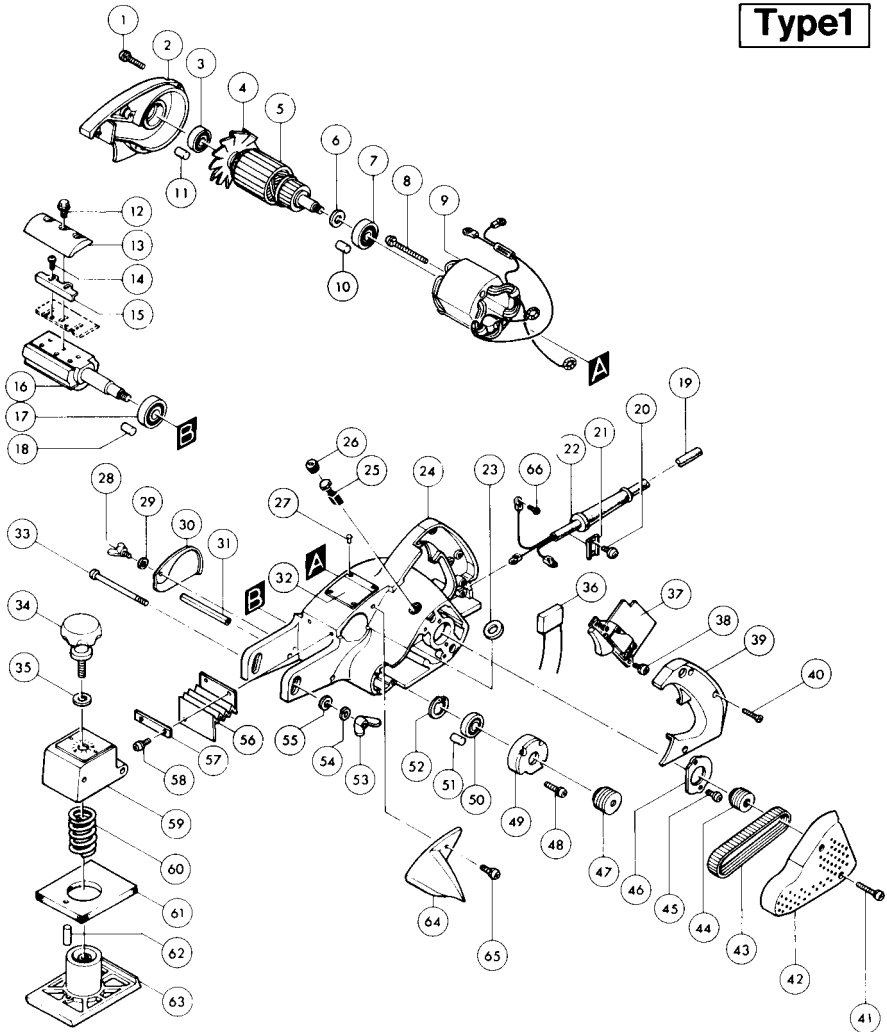

Note: The switch, noise suppressor and other part configurations may differ from country to country.

ITEM NO.	NO. USED	DESCRIPTION	ITEM NO.	NO. USED	DESCRIPTION
<u>MACHINE</u>			<u>MACHINE</u>		
1	4	Pan Head Screw M5x25 (With Washer)	33	1	Set Bolt M8
2	1	Bracket	34	1	Knob 50
3	1	Ball Bearing 6200LLB	35	1	Flat Washer 10
4	1	Fan 80	36	1	Noise Suppressor
5	1	ARMATURE ASSEMBLY (With Item 3 - 7)	37	1	Switch
6	1	Flat Washer 12	38	1	Pan Head Screw M4x8 (With Washer)
7	1	Ball Bearing 6201LLB	39	1	Handle Cover
8	2	Pan Head Screw M5x60 (With Washer)	40	3	Countersunk Head Screw M4x30 (With Washer)
9	1	FIELD ASSEMBLY	41	2	Pan Head Screw M4x30 (With Washer)
10	1	Rubber Pin 6	42	1	Belt Cover
11	1	Rubber Pin 4	43	1	Poly V Belt 6 - 285
12	6	Hex. Flange Head Bolt M6x17	44	1	V-Pulley 6 - 23L
13	2	Drum Plate	45	2	Pan Head Screw M5x10 (With Washer)
14	4	Pan Head Screw M4x5	46	1	Bearing Retainer 44
15	2	Adjust Plate	47	1	V-Pulley 6 - 30
16	1	Drum	48	4	Pan Head Screw M4x25 (With Washer)
17	1	Ball Bearing 6003ZZ	49	1	Drum Housing
18	1	Rubber Pin 6	50	1	Ball Bearing 6001LLB
19	1	Cord	51	1	Rubber Pin 4
20	2	Pan Head Screw M4x14 (With Washer)	52	1	Retaining Ring R - 28
21	1	Strain Relief	53	1	Wing Nut M8
22	1	Cord Guard	54	1	Spring Washer 8
23	2	Insulation Washer	55	1	Flat Washer 8
24	1	Main Frame	56	1	Bellows
25	2	Carbon Brush	57	2	Pressure Plate
26	2	Brush Holder Cap	58	4	Pan Head Screw M4x10 (With Washer)
27	4	Rivet 0 - 5	59	1	Front Box
28	1	Wing Bolt M5x10	60	1	Compression Spring 17
29	1	Spring Washer 5	61	1	Rubber Packing
30	1	Drum Cover	62	1	Spring Pin 5 - 24
31	1	Spring Pin 8 - 80	63	1	Front Base
32	1	Name Plate	64	1	Chip Cover
			65	1	Pan Head Screw M5x14 (With Washer)

Note: The switch, noise suppressor and other part specifications may differ from country to country.

Makita Corporation

3-11-8, Sumiyoshi-cho,
Anjo, Aichi 446 Japan

883000A0

PRINTED IN JAPAN
1991-10 E