



MODEL W1694 6" BENCH TOP JOINTER



INSTRUCTION MANUAL

Phone: 1-360-734-3482 • On-Line Technical Support: tech-support@woodstockint.com

COPYRIGHT © JULY, 2003 BY WOODSTOCK INTERNATIONAL, INC.
WARNING: NO PORTION OF THIS MANUAL MAY BE REPRODUCED IN ANY SHAPE OR FORM WITHOUT
THE WRITTEN APPROVAL OF WOODSTOCK INTERNATIONAL, INC.

Printed in China

WARNING

Some dust created by power sanding, sawing, grinding, drilling, and other construction activities contains chemicals known to the State of California to cause cancer, birth defects or other reproductive harm. Some examples of these chemicals are:

- Lead from lead-based paints.
- Crystalline silica from bricks, cement, and other masonry products.
- Arsenic and chromium from chemically treated lumber.

Your risk from these exposures varies, depending on how often you do this type of work. To reduce your exposure to these chemicals: work in a well ventilated area, and work with approved safety equipment, such as those dust masks that are specially designed to filter out microscopic particles.

CONTENTS

INTRODUCTION	2
About Your New Jointer	2
Woodstock Service and Support	2
Warranty and Returns	3
Specifications	3
SAFETY	4
Standard Safety Instructions	4
Know Your Machine	6
Safety Instructions for Your Jointer	7
Avoiding Potential Injuries	8
ELECTRICAL REQUIREMENTS	9
110V Operation.....	9
Extension Cords	9
Grounding	9
ASSEMBLY	10
Unpacking	10
Inventory.....	10
Shop Preparation	11
Dust Collection	11
Initial Cleaning	11
Rubber Feet	12
Fence Support.....	12
Fence Assembly.....	13
90° Stop Slide.....	14
Dust Port.....	14
ADJUSTMENTS	16
Fence	16
Fence Angle Stops	17
Blade Height.....	19
Depth Of Cut	20
Blade Guard	21
OPERATIONS	22
Test Run	22
Operation Requirements	23
Surface Planing	24
Edge Jointing	25
Bevel Cutting	26
MAINTENANCE	27
General.....	27
Table Surface	27
Sharpening Blades	27
Replacing Blades	28
Guard Spring	29
Lubrication	29
Drive Belts	30
Motor Brushes.....	30
Troubleshooting	31
Parts	35



INTRODUCTION

About Your New Jointer

Your new **SHOP FOX**® Model W1694 6" Bench Top Jointer is specially designed to provide many years of trouble-free service. Close attention to engineering detail, ruggedly built parts, and a rigid quality control program assure safe and reliable operation.

The Model W1694 features a 2 HP, 110V motor, which is capable of 19,000 RPM. The Model W1694 also features a two knife cutterhead with HSS blades, a 2³/₈" dust port with a high-powered suction impeller, a maximum cutting depth of 1/₈", a maximum cutting width of 6¹/₈", and a minimum cutting length of 8¹/₈".

For more features and details, refer to the **Specifications** section in this manual.

Woodstock International, Inc. is committed to customer satisfaction in providing this manual. It is our intent to include all the information necessary for safety, ease of assembly, practical use and durability of this product.

If you need the latest edition of this manual, you can download it from <http://www.shopfox.biz>.
If you still have questions after reading the latest manual, or if you have comments please contact us at:

Woodstock International, Inc.
Attn: Technical Support Department
P.O. Box 2309
Bellingham, WA 98227

Woodstock Service and Support

We stand behind our machines! In the event that a defect is found, parts are missing or questions arise about your machine, please contact Woodstock International Service and Support at 1-360-734-3482 or send e-mail to: tech-support@shopfox.biz. Our knowledgeable staff will help you troubleshoot problems, order parts or arrange warranty returns.

Warranty and Returns

Woodstock International, Inc. warrants all **SHOP FOX**® machinery to be free of defects from workmanship and materials for a period of 2 years from the date of original purchase by the original owner. This warranty does not apply to defects due directly or indirectly to misuse, abuse, negligence or accidents, lack of maintenance, or to repairs or alterations made or specifically authorized by anyone other than Woodstock International, Inc.

Woodstock International, Inc. will repair or replace, at its expense and at its option, the **SHOP FOX**® machine or machine part which in normal use has proven to be defective, provided that the original owner returns the product prepaid to the **SHOP FOX**® factory service center or authorized repair facility designated by our Bellingham, WA office, with proof of their purchase of the product within 2 years, and provides Woodstock International, Inc. reasonable opportunity to verify the alleged defect through inspection. If it is determined there is no defect, or that the defect resulted from causes not within the scope of Woodstock International Inc.'s warranty, then the original owner must bear the cost of storing and returning the product.

This is Woodstock International, Inc.'s sole written warranty and any and all warranties that may be implied by law, including any merchantability or fitness, for any particular purpose, are hereby limited to the duration of this written warranty. We do not warrant that **SHOP FOX**® machinery complies with the provisions of any law or acts. In no event shall Woodstock International, Inc.'s liability under this warranty exceed the purchase price paid for the product, and any legal actions brought against Woodstock International, Inc. shall be tried in the State of Washington, County of Whatcom. We shall in no event be liable for death, injuries to persons or property or for incidental, contingent, special or consequential damages arising from the use of our products.

Every effort has been made to ensure that all **SHOP FOX**® machinery meets high quality and durability standards. We reserve the right to change specifications at any time because of our commitment to continuously improve the quality of our products.

Specifications

Motor Size	2 HP, 110V, Universal-Type Motor
Motor Speed.....	10,000 RPM
Amp Draw	12 A
Maximum Cutting Depth.....	1/8"
Maximum Cutting Width	6 1/8"
Minimum Cutting Length.....	8 1/8"
Cutterhead Blades.....	2 HSS
Machine Weight	92 1/2 lbs

SAFETY

**READ MANUAL BEFORE OPERATING MACHINE.
FAILURE TO FOLLOW INSTRUCTIONS BELOW WILL
RESULT IN PERSONAL INJURY.**



Indicates an imminently hazardous situation which, if not avoided, **WILL** result in death or serious injury.



Indicates a potentially hazardous situation which, if not avoided, **COULD** result in death or serious injury.



Indicates a potentially hazardous situation which, if not avoided, **MAY** result in minor or moderate injury, **MAY** result in property damage.

NOTICE

This symbol is used to alert the user to useful information about proper operation of the equipment.

Standard Safety Instructions

1. **Thoroughly read the instruction manual before operating your machine.** Learn the applications, limitations and potential hazards of this machine. Keep manual in a safe, convenient place for future reference.
2. **Keep work area clean and well lit.** Clutter and inadequate lighting invite potential hazards.
3. **Ground all tools.** If a machine is equipped with a three-prong plug, it must be plugged into a three-hole grounded electrical receptacle or grounded extension cord. If using an adapter to aid in accommodating a two-hole receptacle, ground using a screw to a known ground.
4. **Wear eye protection at all times.** Use safety glasses with side shields or safety goggles that meet the appropriate standards of the American National Standards Institute (ANSI).
5. **Avoid dangerous environments. DO NOT** operate this machine in wet or open flame environments. Airborne dust particles could cause an explosion and severe fire hazard.
6. **Ensure all guards are securely in place** and in working condition.
7. **Make sure the machine power switch is in the OFF position** before connecting power to machine.
8. **Keep the work area clean, free of clutter, grease, etc.**
9. **Keep children and visitors away.** Visitors should be kept at a safe distance while operating unit.
10. **Childproof your workshop** with padlocks, master switches or by removing starter keys.
11. **Stop and disconnect the machine when cleaning, adjusting or servicing.**

12. **DO NOT force tool.** The machine will do a safer and better job at the rate for which it was designed.
13. **Use correct tool. DO NOT force machine or attachment to do a job for which it was not designed.**
14. **Wear proper apparel. DO NOT wear loose clothing, neck ties, gloves, jewelry; and secure long hair away from moving parts.**
15. **Remove adjusting keys, rags, and tools.** Before turning the machine on, make it a habit to check that all adjusting keys and wrenches have been removed.
16. **Avoid using an extension cord.** But if you must, examine the extension cord to ensure it is in good condition. Use the "Extension Cord Requirements" table below to determine the correct length and gauge of extension cord needed for your particular needs. The amp rating of the motor can be found on its nameplate. If the motor is dual voltage, be sure to use the amp rating for the voltage you will be using. If you use an extension cord with an undersized gauge or one that is too long, excessive heat will be generated within the circuit, increasing the chance of a fire or damage to the circuit. Always use an extension cord that uses a ground pin and connected ground wire. Immediately replace a damaged extension cord.
17. **Keep proper footing and balance at all times and lock mobile base from freely rolling before using your machine.**
18. **DO NOT leave machine unattended.** Wait until it comes to a complete stop before leaving the area.
19. **Perform machine maintenance and care.** Follow lubrication and accessory attachment instructions in the manual.
20. **Keep machine away from open flame.** Operating machines near pilot lights and/or open flames creates a high risk if dust is dispersed in the area. Dust particles and an ignition source may cause an explosion. **DO NOT** operate the machine in high-risk areas, including but not limited to, those mentioned above.
21. **If at any time you are experiencing difficulties performing the intended operation, stop using the machine!** Contact our service department or ask a qualified expert how the operation should be performed.
22. **Habits are hard to break.** Develop good habits in your shop and consistent safety practices will become second-nature to you.

Extension Cord Requirements

Amp Rating	Length And Gauge		
	25ft	50ft	100ft
0-6	#16	#16	#16
7-10	#16	#16	#14
11-12	#16	#16	#14
13-16	#14	#12	#12
17-20	#12	#12	#10
21-30	#10	#10	No

⚠ WARNING

Operating this equipment creates the potential for flying debris to cause eye injury. Always wear safety glasses or goggles when operating equipment. Everyday glasses or reading glasses only have impact resistant lenses, they are not safety glasses. Be certain the safety glasses you wear meet the appropriate standards of the American National Standards Institute (ANSI).





Know Your Machine

An important part of safety is knowing your machine and its components. Please take the time to learn the items shown in the pictures below. The letters in the picture correspond to the following descriptions in the text.

SAFETY

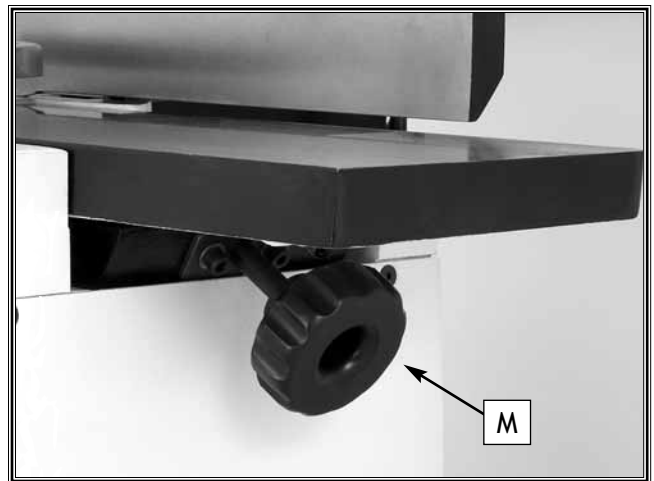
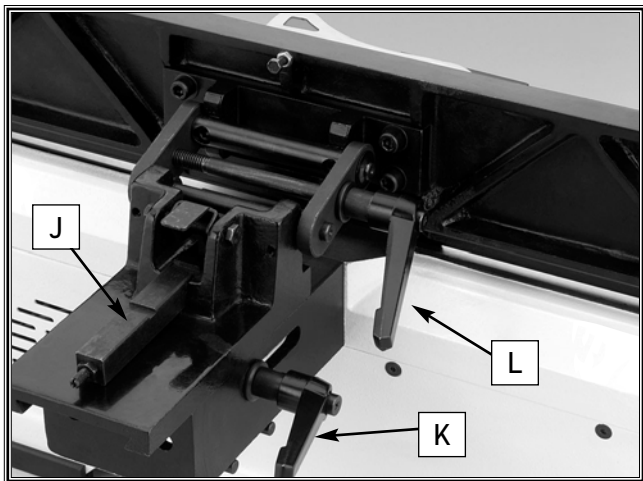
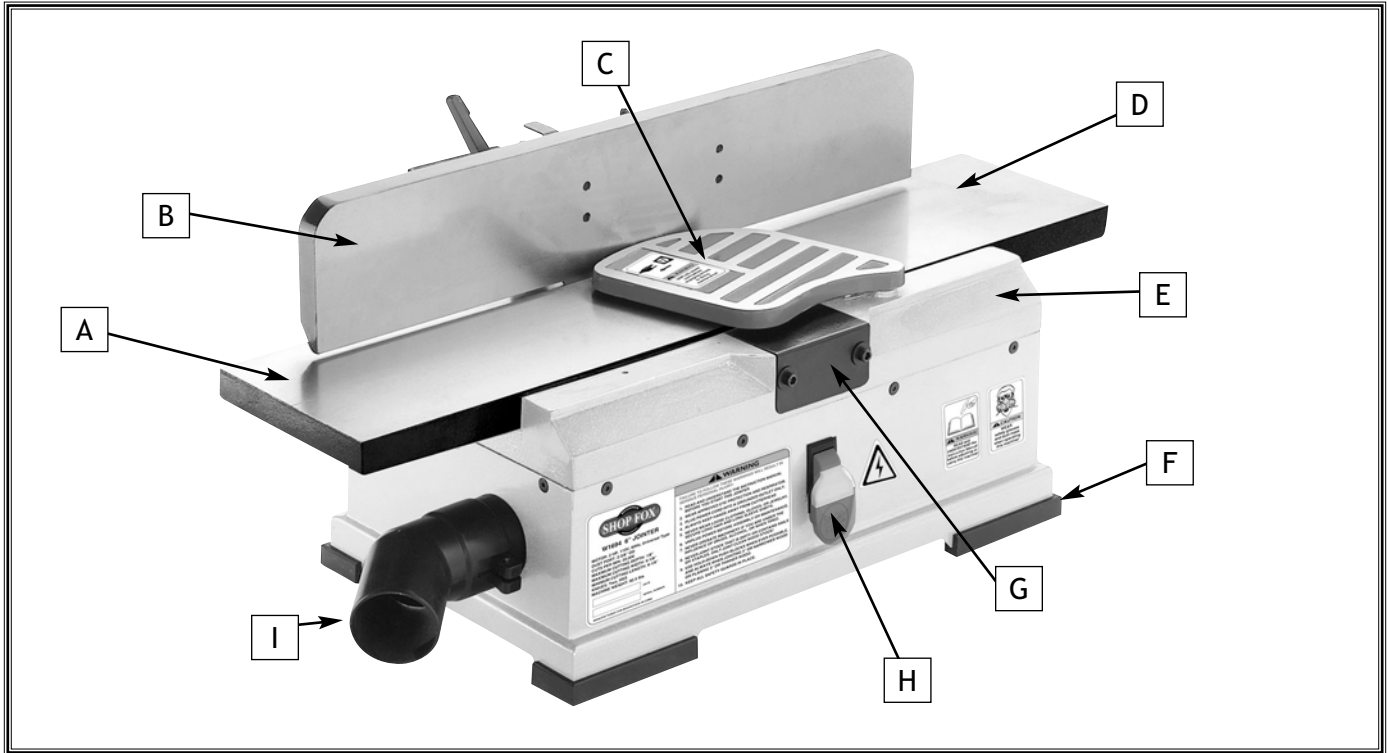

- A. Outfeed Table
- B. Fence
- C. Cutterhead Blade Guard
- D. Infeed Table
- E. Jointer Body
- F. Rubber Feet
- G. Cutterhead Access Cover

- H. Power Switch
- I. Dust Port
- J. 90° Stop Slide
- K. Fence Sliding Handle
- L. Fence Tilting Handle
- M. Table Height Knob

Safety Instructions for Your Jointer



⚠️ WARNING
 READ and understand this entire instruction manual before using this machine. Serious personal injury may occur if safety and operational information is not understood and followed. **DO NOT** risk your safety by not reading!

⚠️ CAUTION
 Use this and other machinery with caution and respect. Always consider safety first, as it applies to your individual working conditions. No list of safety guidelines can be complete—every shop environment is different. Failure to follow guidelines could result in serious personal injury, damage to equipment or poor work results.

SAFETY

1. **JOINTING SAFETY BEGINS WITH YOUR LUMBER.** Inspect your workpiece carefully before you feed it over the cutterhead. If you have any doubts about the stability or structural integrity of your workpiece, **DO NOT JOINT IT!** Unstable workpieces can result in kickback.
2. **MAINTAIN THE PROPER ALIGNMENT** of the outfeed table with the cutterhead knife.
3. **ALWAYS USE PUSH BLOCKS WHEN JOINTING.** Never allow your hands to get near the cutterhead.
4. **SUPPORT AND MAINTAIN CONTROL OVER THE WORKPIECE** at all times during operation.
5. **WHEN JOINTING, DO NOT STAND DIRECTLY BEHIND THE WORKPIECE.** Position yourself just to the side of the infeed table to avoid possible kickbacks.
6. **NEVER MAKE CUTS** deeper than $\frac{1}{8}$ ".
7. **NEVER JOINT A WORKPIECE THAT HAS LOOSE KNOTS, NAILS, STAPLES, OR EMBEDDED DIRT/STONES.** All defects and foreign objects should be removed before use.
8. **NEVER JOINT END GRAIN.**
9. **ALL OPERATIONS MUST BE PERFORMED WITH THE GUARD IN PLACE.**
10. **NEVER CHANGE FEEDING DIRECTIONS DURING A CUT.** Any time the workpiece moves backwards, the chances of kickback and injury are greatly increased.
11. **"KICKBACK"** is when the workpiece is thrown off the jointer table from the force of the cutterhead. Always use push blocks and safety glasses to reduce the likelihood of injury from "kickback." If you do not understand what kickback is, or how it occurs, **DO NOT** operate this machine.
12. **BE AWARE THAT CERTAIN WOODS MAY CAUSE AN ALLERGIC REACTION** in people and animals, especially when exposed to fine dust. Make sure you know what type of wood dust you will be exposed to and always wear an approved respirator.

Avoiding Potential Injuries



Figure 1. Correct operator and workpiece position, guard is in place, and push blocks are being used.



Figure 2. Never surface plane without push blocks!



Figure 3. Never stand directly behind the workpiece!



Figure 4. Never plane/edge-joint with the guard removed!



Figure 5. Never joint end grain!

ELECTRICAL REQUIREMENTS

110V Operation

The **SHOP FOX**® Model W1694 2 HP, 110 volt motor draws approximately 12 amps.

Since other machines may be using the same circuit, make sure the circuit, circuit breaker, or fuse can carry the total load without tripping. If the total amperage load of all machines and the jointer exceeds the amperage rating of the circuit breaker or fuse, use a different circuit that can carry the load.

DO NOT modify an existing low-amperage circuit by only replacing the circuit breaker with a breaker rated for a higher amperage. The breaker and the complete circuit must be replaced by a qualified electrician, otherwise the wires can overheat and cause a fire.

Extension Cords

If you must use an extension cord with the Model W1694, please follow these requirements:

- Use a cord rated for Standard Service (Grade S).
- Use a 14 AWG cord that is 100 feet or less
- Use a cord with a ground pin
- Use an undamaged cord only

Grounding



Ground this machine! The electrical cord supplied with the **SHOP FOX**® Model W1694 Jointer has a three prong plug for grounded outlets. See **Figure 6**. If your power receptacle does not have a ground pin hole, have the receptacle replaced by a qualified electrician, or have an appropriate adapter installed and grounded properly. NEVER cut the ground pin off so your jointer will plug into a non-grounded receptacle.

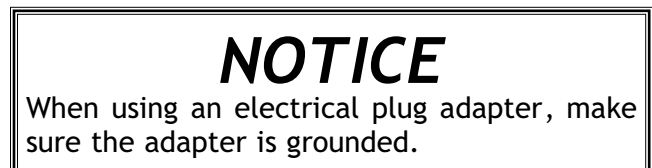

Remember, an adapter with a grounding wire does not guarantee the jointer is grounded. A ground source must always be verified in the electrical circuit within the wall or conduit.

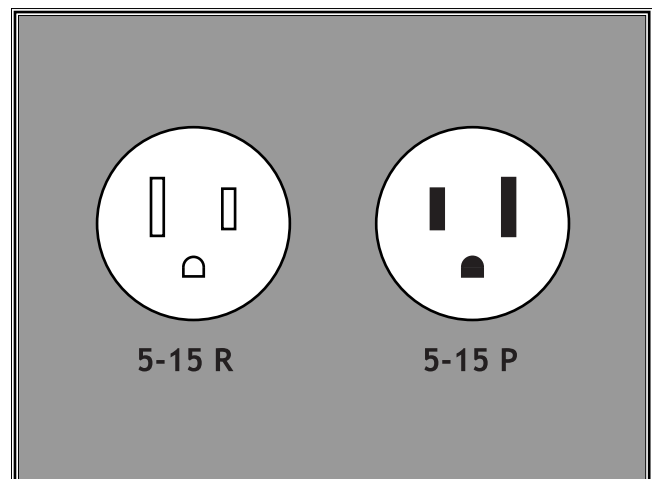

Figure 6. NEMA-style 5-15 plug and receptacle.

ASSEMBLY

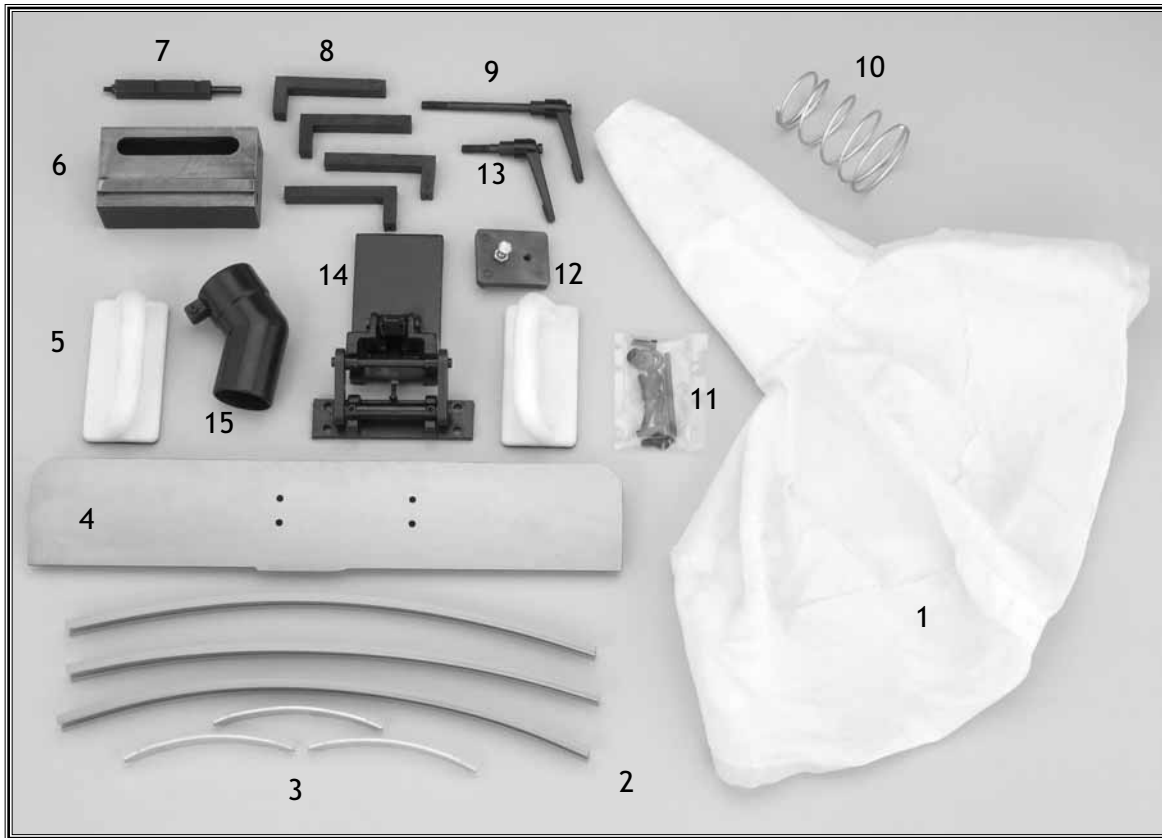



Figure 7. Loose parts shipped with the jointer.

ASSEMBLY



⚠ CAUTION

The Model W1694 is a heavy machine at 92¹/₂ lbs. Use assistance when lifting or moving the machine.

Unpacking

The Model W1694 was carefully packed when it left our warehouse. If you receive it damaged or missing any parts, please contact Woodstock International Service and Support at 1-360-734-3482 or send e-mail to: tech-support@shopfox.biz.

Layout and inventory the package contents listed to the right and familiarize yourself with the components shown in **Figure 7** to ease assembly.

Inventory

Item	Qty
1. Filter Bag	1
2. Trash Bag Support Segments	3
3. Connectors	3
4. Fence	1
5. Push Blocks	2
6. Fence Support	1
7. 90° Slide Stop	1
8. Rubber Feet.....	4
9. Fence Tilting Handle	1
10. Filter Bag Spring	1
11. Hardware Bag	1
• Cap Screws M8-1.25 x 20	6
• Flat Washers 8mm	6
• Allen Wrench Set	1
• Handle Spacers	2
12. Locking Plate Assembly	1
13. Fence Sliding Handle	1
14. Fence Adjusting Bracket	1
15. Dust Port.....	1

Shop Preparation

	<p>⚠ CAUTION ONLY ALLOW TRAINED PEOPLE in your shop! Make sure shop entrances are locked and machines are correctly turned off with lock-out devices when not in use. Otherwise, injury or death can occur.</p>
--	--

- **Lighting:** Lighting should be bright enough to eliminate shadows and prevent eye strain.
- **Working Clearances:** Consider your current and future shop needs with respect to the safe operation of this machine.
- **Outlets:** Make sure the electrical circuits have the capacity to handle the amperage requirements for your Model W1694. Refer to **page 9** for more information. Electrical outlets should be located near the lathe, so power or extension cords are clear of high-traffic areas.

Dust Collection

	<p>⚠ CAUTION THIS MACHINE produces sawdust that may cause allergic reactions or respiratory problems. Wear a dust mask or respirator in addition to using a dust collection system.</p>
--	--

For information on the correct dust collection components for the jointer, contact your Woodstock International dealer for a copy of the Dust Collection Basics handbook and available accessories.

Initial Cleaning

The exposed and unpainted jointer surfaces are coated with a waxy oil to prevent rust during storage and shipment. **DO NOT** use chlorine based solutions or solvents to remove the this waxy oil, or you will damage the painted surfaces. Remove the waxy oil with a solvent based degreaser before you use the jointer. Always follow all usage and safety instructions of the product that you are using.

	<p>⚠ WARNING DO NOT use flammables such as gas or other petroleum-based solvents to clean your machine. These products have low flash points and present the risk of explosion and severe personal injury!</p>
--	---

	<p>⚠ WARNING DO NOT smoke while using cleaning solvents. Smoking may cause explosion or risk of fire when exposed to these products!</p>
--	---

	<p>⚠ CAUTION ALWAYS work in a well ventilated area when using solvents with fumes, and keep away from any potential ignition sources (pilot lights). Most solvents used to clean machinery are toxic when inhaled or ingested. Always dispose of waste rags in a sealed container to make sure they do not cause fire or environmental hazards.</p>

ASSEMBLY

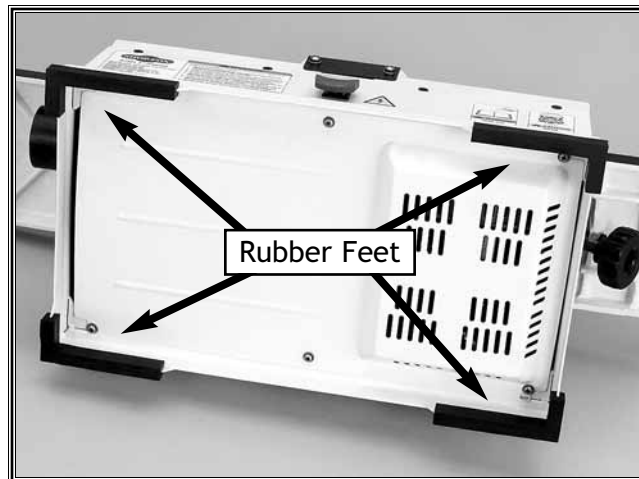
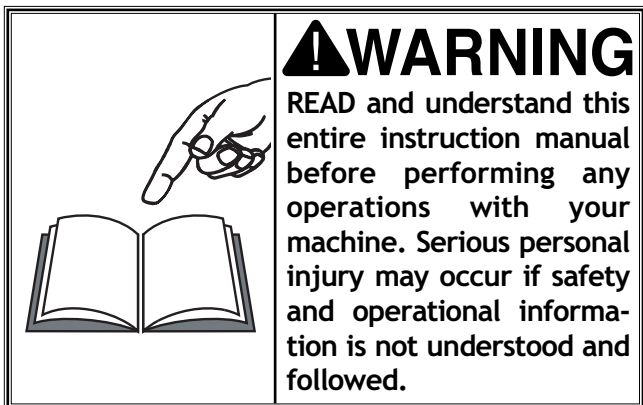
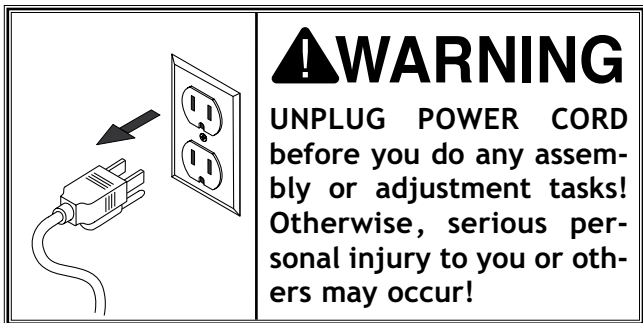

Figure 8. Attached rubber feet.



Figure 9. Aligning the fence support.

Rubber Feet

To attach the rubber feet, do these steps:

Slide the four rubber feet onto the four corners of the jointer base (Figure 8).

Fence Support

To attach the fence support, do these steps:

1. Align the fence support with the mounting holes on the back of the jointer (Figure 9). *Make sure the slot on the top of the fence support is positioned correctly.*
2. Secure the fence support to the jointer with two 8mm flat washers and two M8-1.25 x 20 cap screws.
3. Secure the locking plate assembly to the fence support with the fence sliding handle (Figure 10).

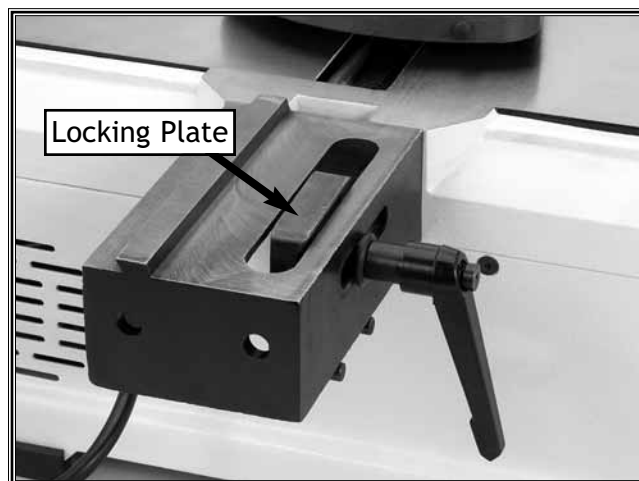

Figure 10. Secured locking plate.

Fence Assembly

The fence assembly consists of the fence, the fence adjusting bracket, and the fence tilting handle.

To assemble the fence assembly, do these steps:

1. Attach the fence to the fence adjusting bracket with four 8mm flat washers and four M8-1.25 x 20 cap screws (**Figure 11**).
2. Slide the fence assembly over the dovetail way and onto the fence support (**Figure 12**).
3. Secure the fence assembly to the fence support by tightening the fence sliding handle.
4. Secure the fence position by threading the fence tilting handle through the fence adjusting bracket (**Figure 13**). *Further adjustment of the fence will be discussed in the **Adjustments** section.*

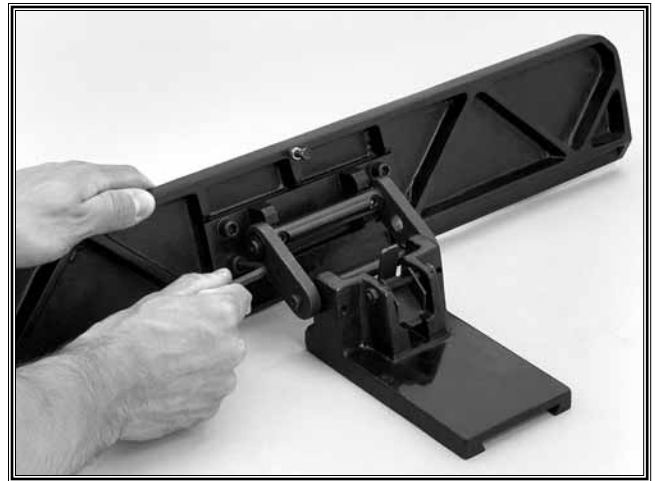

Figure 11. Attaching the fence to the fence adjusting bracket.

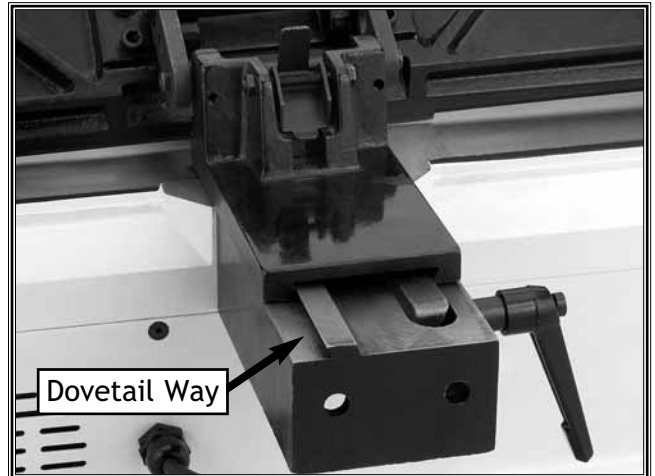

Figure 12. Fence assembly on dovetail way.

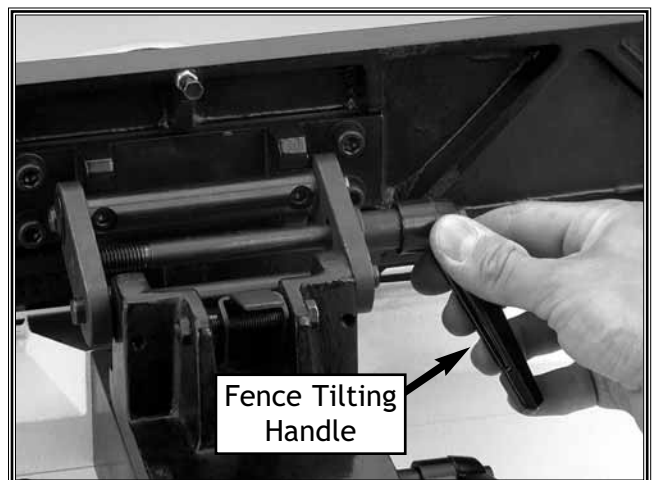

Figure 13. Securing the fence tilting handle.

90° Stop Slide

To install the 90° stop slide, do these steps:

Slide the 90° stop slide under the limit plate as shown in **Figure 14**. Do not worry about its exact position at this time. *Further adjustment of the 90° stop slide will be discussed in the Adjustments section.*

Dust Port

The Model W1694 has a 2½" dust port with a built-in suction impeller. The dust port can connect to a standard 30 gallon trash can or a 30 gallon plastic trash bag.

To connect the dust port to a trash can, do these steps:

1. Slip the filter bag spring into the filter bag arm (**Figure 15**).
2. Slide the filter bag arm over the dust port.
3. Secure the filter bag over the rim of the trash can with the filter bag band (**Figure 16**).

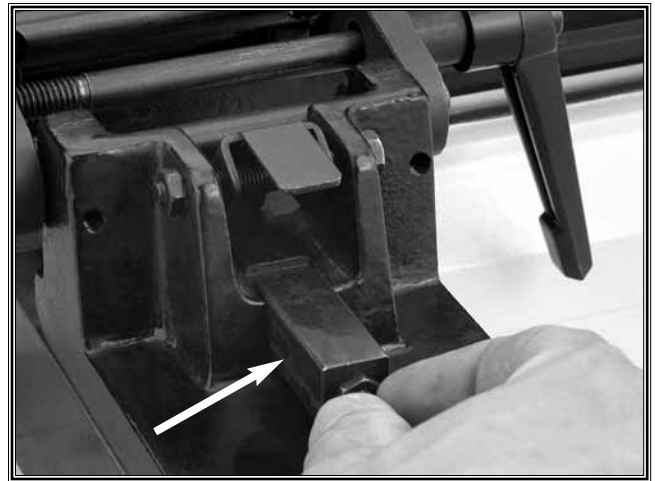

Figure 14. Installing the 90° stop slide.



Figure 15. Correctly installed filter bag spring.



Figure 16. Filter bag secured to the trash can.

To connect the dust port to a trash bag, do these steps:

1. Slip the filter bag spring into the filter bag arm.
2. Slide the filter bag arm over the dust port.
3. Assemble the trash bag support by sliding the connectors into the channels of the trash bag support segments (**Figure 17**).
4. Slide the opening of the trash bag inside and over the trash bag support (**Figure 18**). *Let the trash bag hang over approximately 3"-4".*
5. Secure the filter bag to the trash bag/support assembly with the filter bag band (**Figure 19**). *Make sure the filter bag band rests in the channel of the trash bag support.*



Figure 17. Assembling the trash bag support.

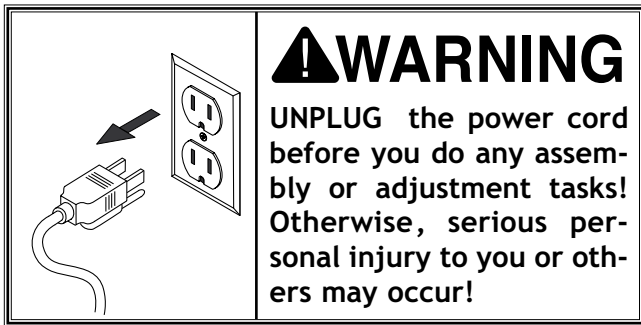

Figure 18. Sliding the trash bag over the trash bag support.



Figure 19. Filter bag secured to the trash bag.

ADJUSTMENTS



Fence

The fence assembly has two primary methods of adjustment:

- The face of the fence is adjustable relative to the table surface.
- The fence position is adjustable across the width of the table.

To adjust the fence face angle relative to the table surface, do these steps:

1. Loosen the fence tilting handle (Figure 20).
2. Move the fence face to the desired position. *Precise angle stops will be discussed in the Fence Angle Stops sub-section.*
3. Tighten the fence tilting handle.

To adjust the fence position across the width of the table, do these steps:

1. Loosen the fence sliding handle (Figure 20).
2. Move the fence to the desired position across the width of the table. *The fence position is adjustable to accommodate workpieces of varying widths and to promote even blade usage and wear.*
3. Tighten the fence sliding handle.

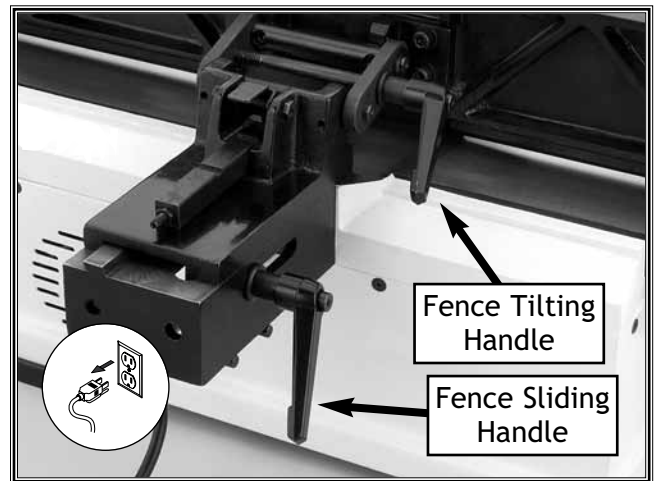

Figure 20. Fence bracket assembly.

Fence Angle Stops

There are three fence angle stops: 90°, 45° inward, and 45° outward. The angle stops allow the fence to be quickly and accurately positioned at various angles.

To adjust the 90° angle stop, do these steps:

1. Using a machinist's square, position the fence 90° relative to the table surface (Figure 21).
2. Position the limit plate in the forward slot of the 90° slide stop.
3. Loosen the jam nut on the 90° stop slide.
4. Using a flat-head screwdriver, adjust the setscrew on the 90° stop slide until the peg makes contact with the back of the fence (Figure 22).
5. Retighten the jam nut loosened in step 3.

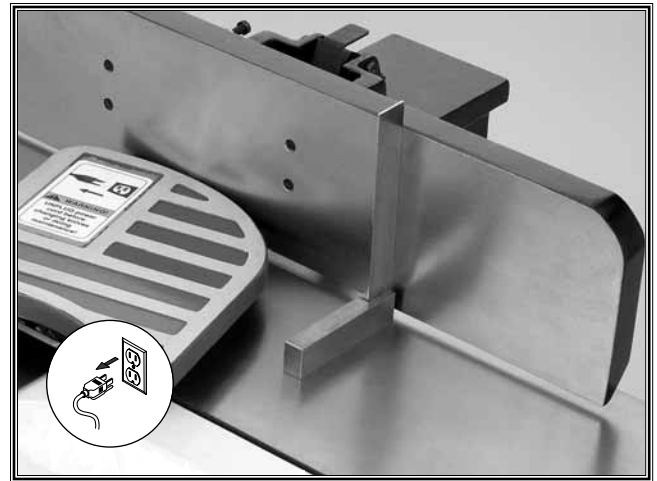

Figure 21. Setting the fence to 90°.

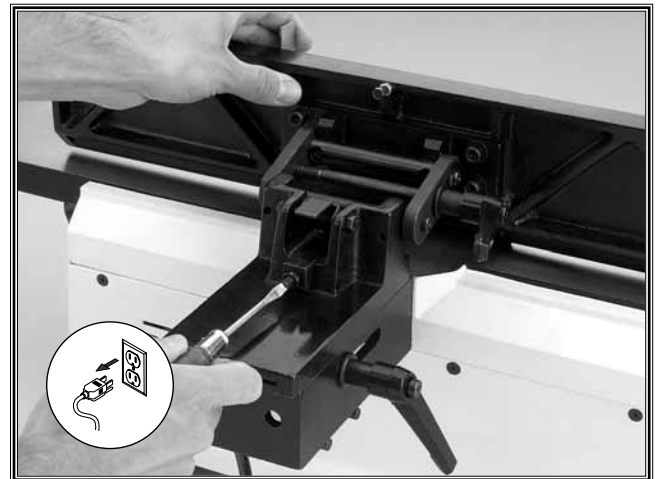

Figure 22. Adjusting the 90° stop slide.

To adjust the 45° inward angle stop bolt, do these steps:

1. Slide the 90° stop slide away from the back of the fence.
2. Using a 45° square, position the fence 45° relative to the table surface.
3. Loosen the jam nut on the 45° inward stop bolt (Figure 23).
4. Adjust the 45° inward stop bolt until it makes contact with the back of the fence.
5. Retighten the jam nut loosened in step 3.

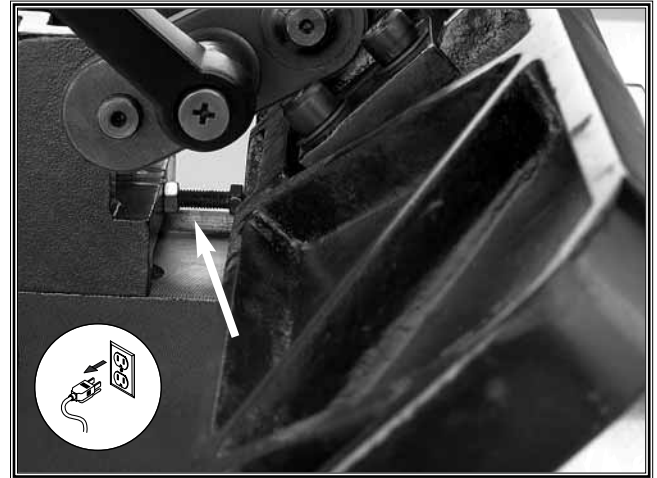

Figure 23. 45° inward angle stop bolt.

To adjust the 45° outward angle stop bolt, do these steps:

1. Using a sliding bevel adjusted to 135°, position the fence 135° (45° outward) relative to the table surface.
2. Loosen the jam nut on the 45° outward stop bolt (Figure 24).
3. Adjust the 45° outward stop bolt until it makes contact with the fence adjusting bracket.
4. Retighten the jam nut loosened in step 2.

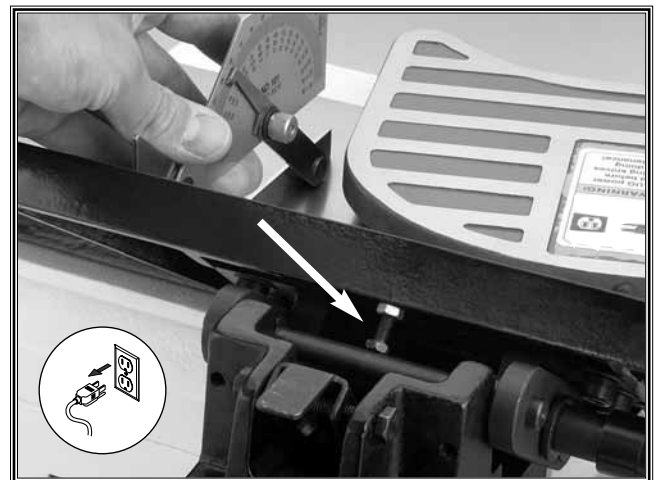

Figure 24. 45° outward angle stop bolt.

Blade Height

The blade height must be adjusted correctly to increase the time between sharpenings, allow maximum performance, and to ensure a flat jointed surface. Check the blade height whenever the blades are removed from the cutterhead or whenever cutting performance begins to degrade.

To check the cutterhead blade height, do these steps:

1. UNPLUG THE JOINTER!
2. Use a 6¹/₄" wide piece of wood to prop the blade guard open.
3. Rotate the cutterhead until one of the blades is at its highest position (**Figure 25**).
4. Place a straightedge across the outfeed table and over the top of the cutterhead blade.
5. At both ends of the cutterhead, the straightedge must just make contact with the blade (**Figure 26**). *Watch and make sure the straightedge is not lifted from the outfeed table surface when contact is made with the cutterhead blades.*
 - If the straightedge makes contact on both ends of the cutterhead blade, then continue to the next sub-section.
 - If the straightedge does not make contact with both ends of the cutterhead blade, then continue to the next step.
6. Loosen the four blade clamp screws that secure the blade in the cutterhead (**Figure 27**).
7. Adjust the jack screws under the blade until both ends of the cutterhead blade make contact with the straightedge.
8. Retighten the four blade clamping screw and repeat **steps 3 - 7** on the second blade.
9. Remove the wood that is holding the blade guard open.

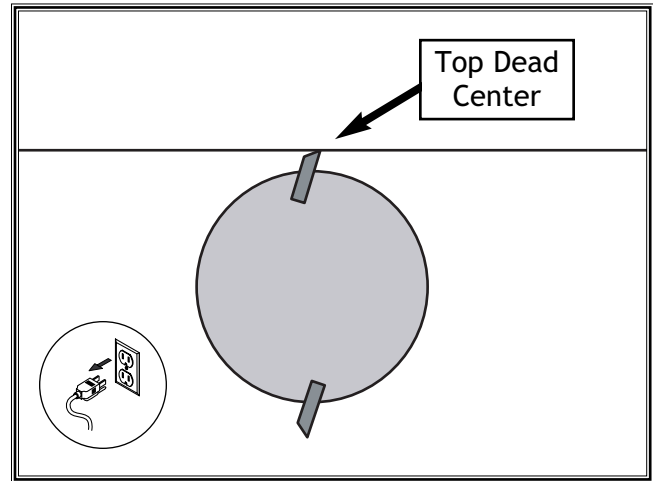

Figure 25. Blade is positioned at its highest position (Top Dead Center).

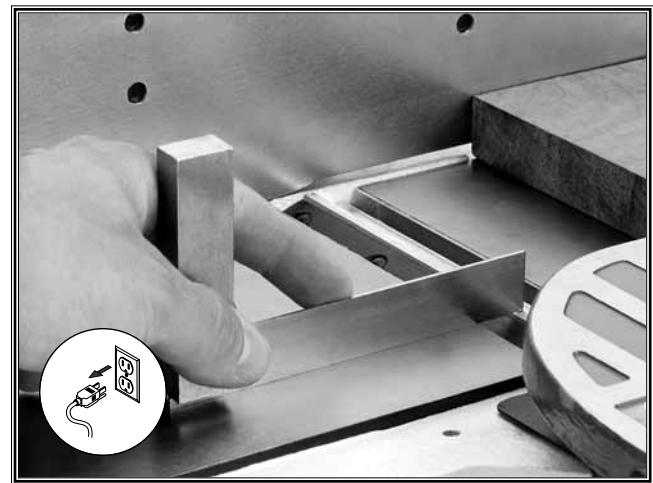

Figure 26. Checking the blade height.

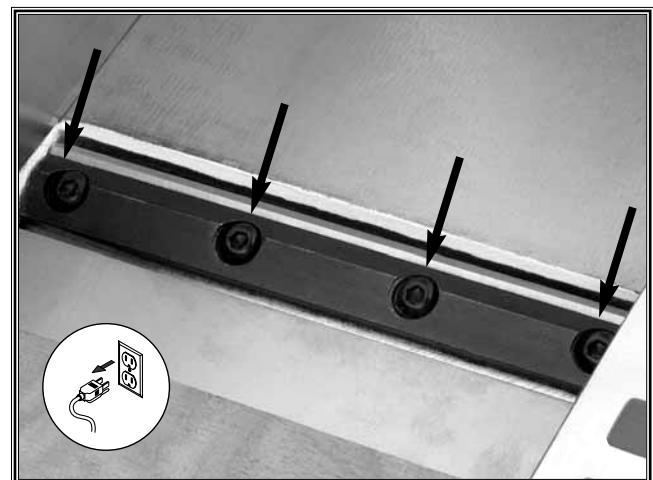

Figure 27. Blade clamp screws.

Depth Of Cut

The depth of cut is equal to the distance between the infeed table surface and the top of the cutterhead blade at top-dead-center (**Figure 28**). The depth of cut is adjusted by raising and lowering the infeed table.

To adjust the depth of cut:

- Turn the table height knob (**Figure 29**) clockwise to raise the infeed table, thereby reducing the depth of cut.
- Turn the knob counter-clockwise to lower the infeed table, thereby increasing the depth of cut.

Never remove more than 1/8" of material from the workpiece in a single pass.

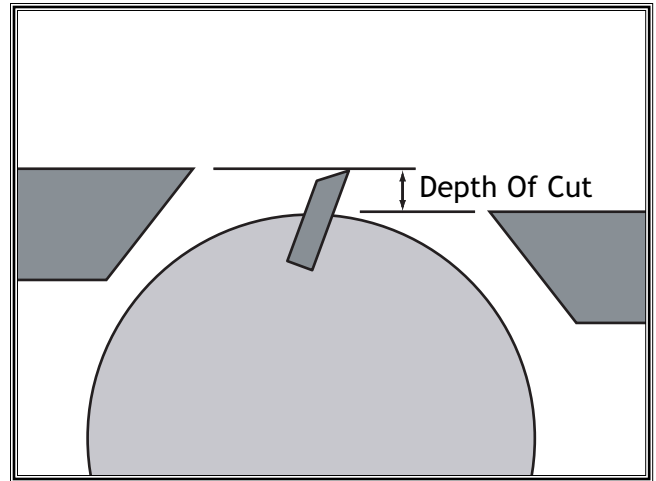

Figure 28. Depth of cut.

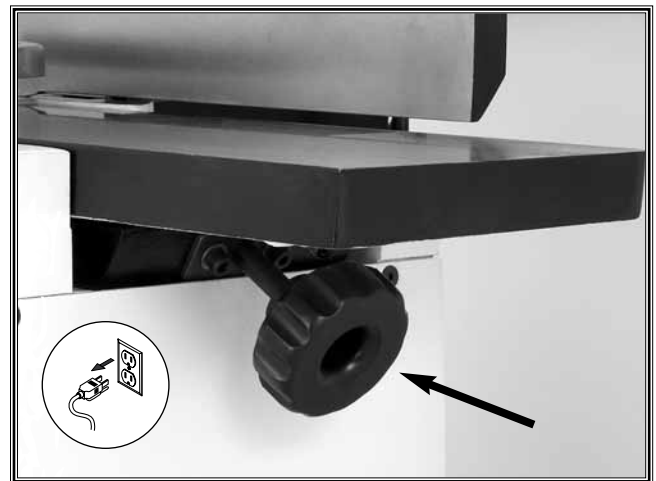

Figure 29. Table height knob.

Blade Guard

The blade guard protects the operator from the cutterhead blades. It must be functioning correctly before performing any jointing operation.

To make sure the blade guard is functioning correctly, do these steps:

1. UNPLUG THE JOINTER!
2. Adjust the infeed table even with the out-feed table.
3. Slide a piece of wood across the jointer as if performing an actual jointing operation.
 - The blade guard should rotate enough to allow the wood to pass over the cutterhead (**Figure 30**).
 - Once the wood has passed over the cutterhead, the blade guard should swing completely back over the cutterhead.
4. Swing the blade guard completely open and release it.
 - The blade guard should swing completely back over the cutterhead.



Figure 30. Blade guard in use.

OPERATIONS

Test Run

Once assembly is complete, the machine is ready for a test run. The purpose of a test run is to identify any unusual noises and vibrations, as well as to confirm that the machine is performing as intended.

To test run the Model W1694, do these steps:

1. Make sure that all tools have been removed from the jointer.
2. Turn the jointer ON.
3. Once the jointer is running, listen for any unusual noises. The machine should run smoothly with little or no vibrations.
 - If there are any unusual noises or vibrations, stop the jointer immediately by pushing the paddle switch down.
4. Unplug the jointer and investigate the source of the noise or vibration. DO NOT make any adjustments to the jointer while it is plugged in. The jointer should not be run any further until the problems are corrected.

	<p>⚠ WARNING THIS MACHINE throws wood chips and sawdust. Wear safety glasses or a face shield during all operations.</p>
--	--

	<p>⚠ WARNING KEEP loose clothing rolled up and out of the way of machinery and keep hair pulled back.</p>
--	---

	<p>⚠ CAUTION THIS MACHINE produces sawdust that may cause allergic reactions or respiratory problems. Wear a dust mask or respirator in addition to using a dust collector.</p>
---	---

Operation Requirements

- Never allow hands or push blocks to come within 4" of the cutterhead while it is moving.
- Carefully inspect boards before jointing. Defects such as twisting, knots, or cracks could cause the workpiece to break apart.
- Only use clean boards. Remove all dirt, nails, staples, imbedded gravel, etc. from boards before jointing. Dirt and debris can damage the cutting edge of the cutterhead blades, resulting in unsatisfactory results.
- DO NOT joint man-made products such as MDF, OSB, or plywood. Also, never use laminates, formica or other synthetic materials.
- Always joint "with" the grain. Cutting "with" the grain is best described as feeding boards on the jointer so the grain points down and toward you as viewed on the edge of the workpiece (**Figure 31**).
- Avoid using wood with a high moisture content. Boards with more than 20% moisture will cause unnecessary wear on the cutterhead blades and motor.
- Never take cuts deeper than $\frac{1}{8}$ ". Making several shallow cuts will produce a better finished result than one deep cut.
- Keep work area clean and free of clutter.

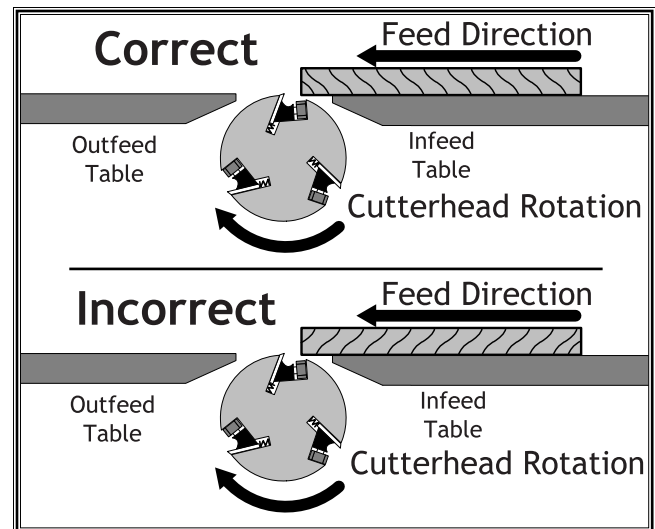

Figure 31. Correct and incorrect grain alignment to cutterhead.

Surface Planing

Surface planing flattens the concave face of the workpiece in preparation for surface planing on a thickness planer (Figure 32). The flat face allows the thickness planner to produce a workpiece that is flat and uniformly thick.

Figure 33 shows an example of an operator using the jointer to surface plane a workpiece. Notice that the operator's body is not directly behind the workpiece and that the operator is using push blocks.

To perform a surface planing operation, do these steps:

1. Read and become familiar with the **Operation Requirements** sub-section.
2. Place the workpiece so the concave side is down on the infeed table and press the workpiece firmly against the fence.
3. Start the jointer.
4. Using push blocks, feed the workpiece through the jointing operation. *Make sure to maintain even downward pressure.*
5. When your leading hand gets within 4" of the cutterhead, lift the push block up and over the cutterhead and place it on the workpiece as it passes over the outfeed table. Do the same thing when your trailing hand gets within 4" of the cutterhead and try to maintain pressure on the outfeed table.
6. Repeat steps 4-5 until the surface is flat.

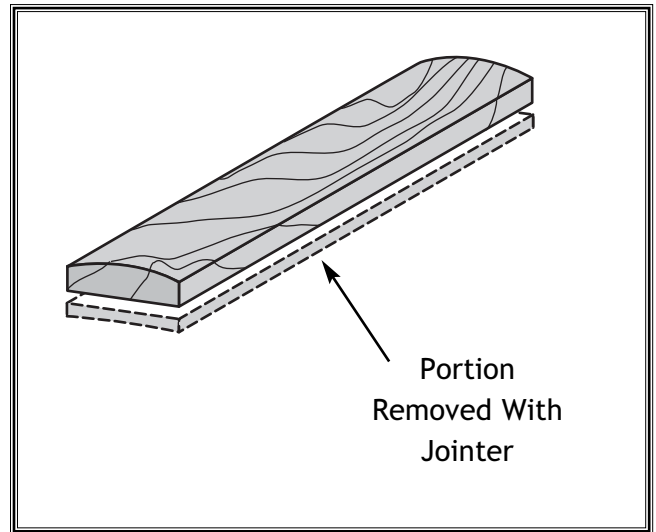

Figure 32. Surface planing flattens the concave face of the workpiece.

	<p>! WARNING ALWAYS wear safety glasses to prevent serious personal injury!</p>
--	--



Figure 33. This is an example of a surface planing operation.

Edge Jointing

Edge jointing straightens the concave edge of the workpiece (Figure 34). This straight edge can then be guided along the rip fence of a table saw when squaring rough lumber. The straight, flat edge is also used for gluing up large panel assemblies.

Figure 35 shows an example of an operator edge jointing. Notice that the operator's body is not directly in line with the workpiece and that he maintains a stable hand position while keeping the workpiece firmly on the table and against the fence.

To perform an edge jointing operation, do these steps:

1. Read and become familiar with the **Operation Requirements** sub-section.
2. Place the workpiece so the concave edge is down on the infeed table and press the workpiece firmly against the fence.
3. Start the jointer.
4. Feed the workpiece through the jointing operation. *Make sure to maintain even downward pressure.*
5. If your leading hand gets within 4" of the cutterhead, lift it up and over the cutterhead and place it on the workpiece as it passes over the outfeed table. Do the same thing when your trailing hand gets within 4" of the cutterhead and try to maintain pressure on the outfeed table.
6. Repeat steps 4-5 until the edge is flat.

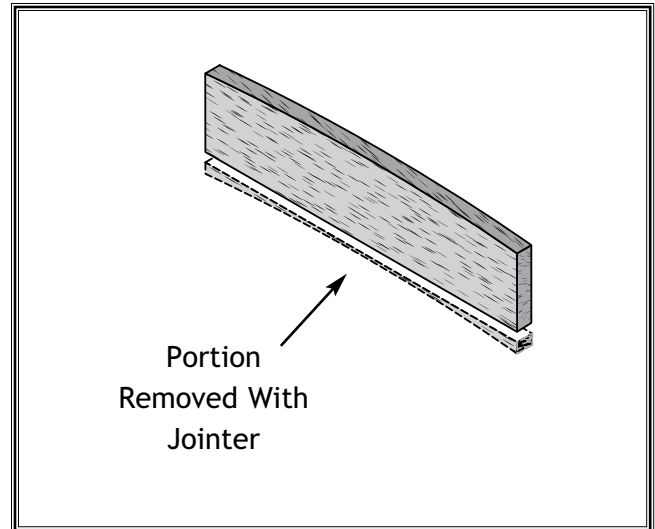

Figure 34. Edge jointing straightens the concave edge of the workpiece.



Figure 35. This is an example of an edge jointing operation.

Bevel Cutting

Bevel cutting is very similar to edge jointing, but done with the fence tilted to a specific angle in order to produce an angled edge (**Figure 36**). Usually bevel cuts are made on two boards that will be joined together at a corner.

For bevel cuts, the Model W1694 has preset stops at 45° inward and 45° outward. If a different angle is desired, use a bevel gauge to set the fence, then lock it in position.

Figure 37 shows an example of an operator bevel cutting at 45° outward. Notice that the operator's body is not directly in line with the workpiece and that he maintains a stable hand position while keeping the workpiece firmly on the table and against the fence.

To perform a bevel cutting operation, do these:

1. Read and become familiar with the **Operation Requirements** sub-section.
2. Set the fence to the desired angle. Place the workpiece down on the infeed table and press it firmly against the fence.
3. Start the jointer.
4. Keep the workpiece firmly against the table and fence, and feed the workpiece into the cutterhead.
5. When your leading hand gets within 4" of the cutterhead, lift the push block up and over the cutterhead and place it on the workpiece as it passes over the outfeed table. Do the same thing when your trailing hand gets within 4" of the cutterhead and try to maintain pressure on the outfeed table.
6. Repeat **steps 4-5** until the edge is flat.

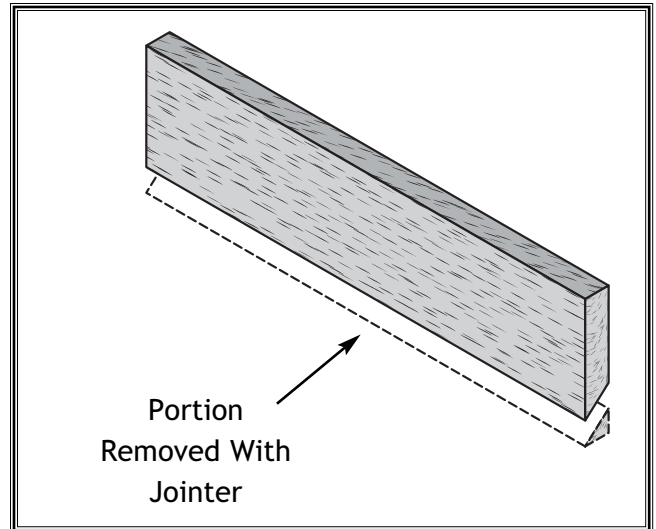

Figure 36. Bevel cutting produces an angled edge on the workpiece.

	<p>! WARNING Always wear safety glasses to prevent serious personal injury!</p>
--	--



Figure 37. This is an example of a bevel cutting operation with the fence set at 45°.

MAINTENANCE

General

Regular periodic maintenance on your Model W1694 will ensure its optimum performance. Make a habit of inspecting your machine each time you use it. **Check for the following conditions and repair or replace when necessary:**

- Loose mounting bolts.
- Worn switch.
- Worn or damaged cords and plugs.
- Any other condition that could hamper the safe operation of this machine.

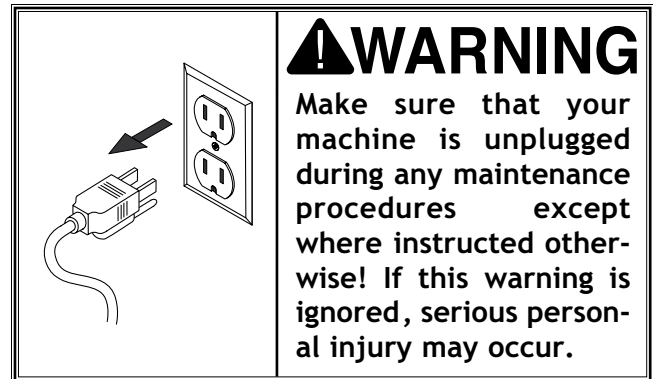

Table Surface

Tables can be kept rust-free with regular applications of products like SLIPIT®. For long term storage you may want to consider products like Boeshield T-9™. Whichever product you ultimately choose for a table lubricant, make sure that it protects against rust, allows the workpiece to slide easily and will not stain expensive workpieces.

Sharpening Blades

Correct blade sharpening and honing techniques are beyond the scope of this manual. Have the blades professionally sharpened for the best results.

Replacing Blades

To replace the cutterhead blades, do these steps:

1. UNPLUG THE JOINTER!
2. Use a 6 $\frac{1}{4}$ " wide piece of wood to prop the blade guard open.
3. Remove the four blade clamping screws on one of the blades (**Figure 38**).
4. Remove the blade and clamp from the cutterhead.
5. Slide the replacement blade and clamp into the cutterhead.
6. Place a straightedge across the outfeed table and over the top of the cutterhead blade.
7. At both ends of the cutterhead, the straightedge must make contact with the blade (**Figure 39**). *Watch and make sure the straightedge is not lifted from the outfeed table surface when contact is made with the cutterhead blades.*
 - If the straightedge makes contact on both ends of the cutterhead blade, then continue to **step 9**.
 - If the straightedge does not make contact with both ends of the cutterhead blade, then continue to the next step.
8. Adjust the jack screws under the blade until both ends of the cutterhead blade make contact with the straightedge (**Figure 40**).
9. Retighten the four blade clamping screws loosened in **step 3** and repeat **steps 3-7** on the second blade.
10. Remove the wood that is holding the blade guard open.

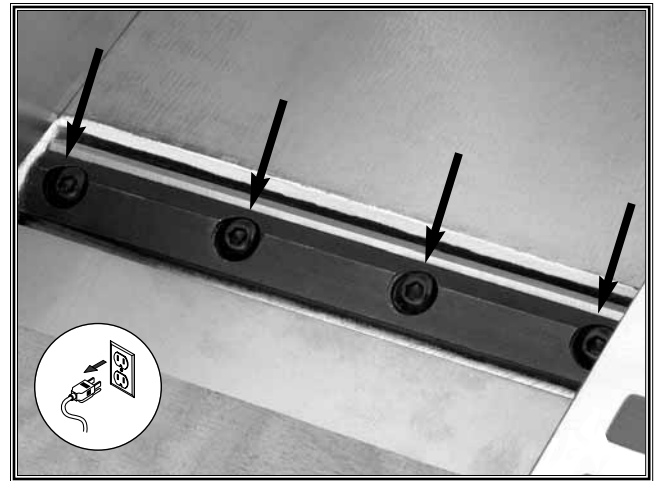

Figure 38. Blade clamping screws.

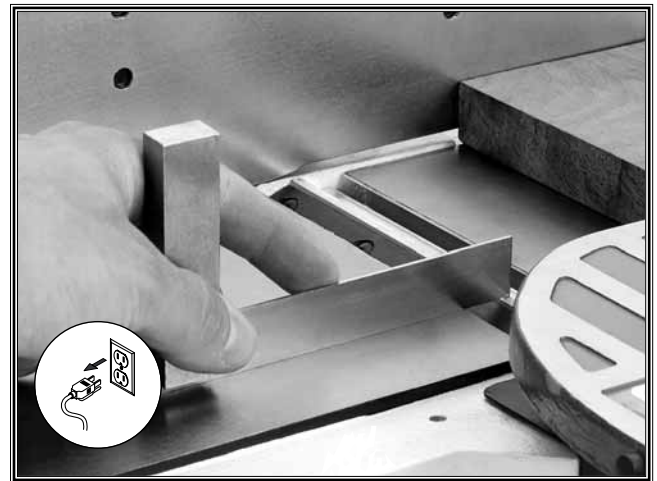

Figure 39. Checking the blade height.

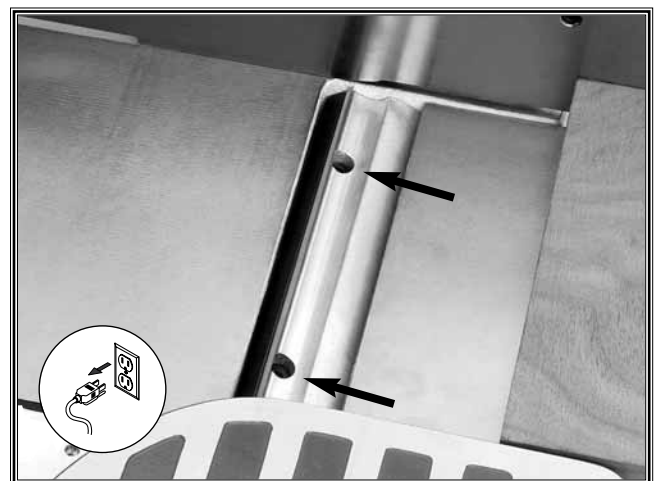

Figure 40. Jack screws.

Guard Spring

To replace a worn out blade guard spring, do these steps:

1. Lay the jointer on its side so the switch is facing up.
2. Remove the bottom cover.
3. Remove the screw that secures the blade guard from beneath and remove the blade guard (**Figure 41**).
4. Remove the screw that secures the blade guard spring and remove the spring (**Figure 42**). *Make note of the spring position before removal. This will simplify installing the new spring.*
5. Reverse the above steps to re-install the blade guard.
6. Test the blade guard to make sure it is functioning correctly.

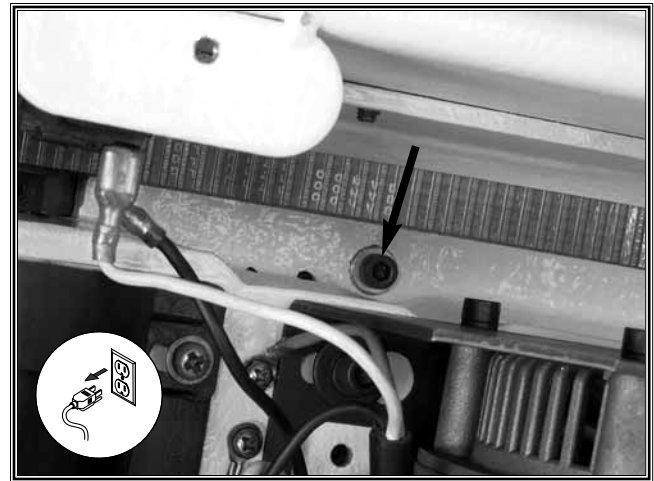

Figure 41. Blade guard mounting screw.

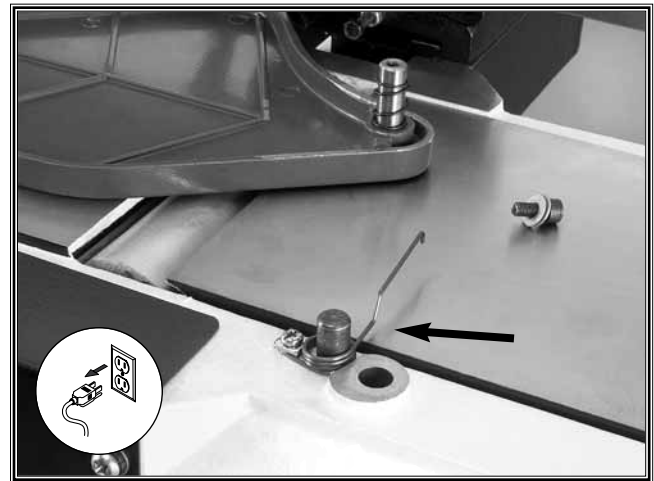

Figure 42. Blade guard spring.

Lubrication

Since all bearings are sealed and permanently lubricated, simply leave them alone until they need to be replaced. Do not lubricate them.

For the moving mechanisms on the fence assembly, an occasional application of light machine oil is all that is necessary. Before applying lubricant, wipe the fence clean. Lubricate the pivot points and move the fence back and forth as shown in **Figure 43**. Your goal is to achieve adequate lubrication. Too much lubrication will attract dirt and sawdust.

Finally, keep the sliding surfaces clean and free of any dirt or sawdust. Give these areas, especially the key and keyway, an application of powdered graphite. Powdered graphite works great because it does not attract dirt or sawdust.

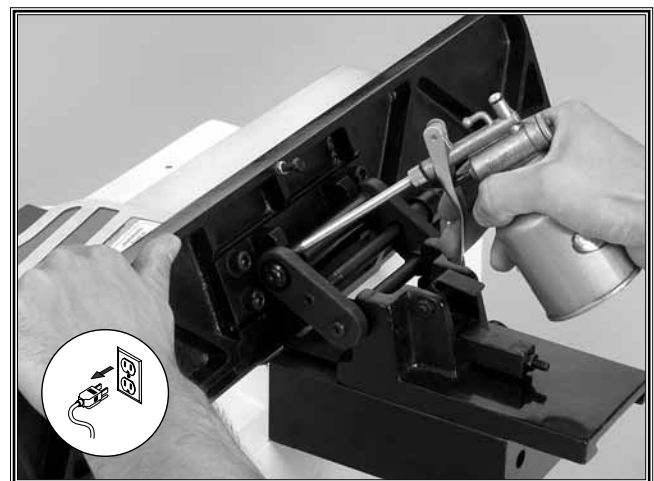

Figure 43. Lubricating fence pivot points.

Drive Belts

To replace the drive belts, do these steps:

1. Lay the jointer on its side so the switch is facing up.
2. Remove the bottom cover.
3. Loosen the screws securing the motor mount plate and the impeller mount plate (**Figure 44**).
4. Adjust the mounting plate to allow the drive belts to loosen.
5. Remove the drive belts.
6. Replace or re-install the drive belts, making sure they are aligned correctly.
7. Replace the bottom cover.

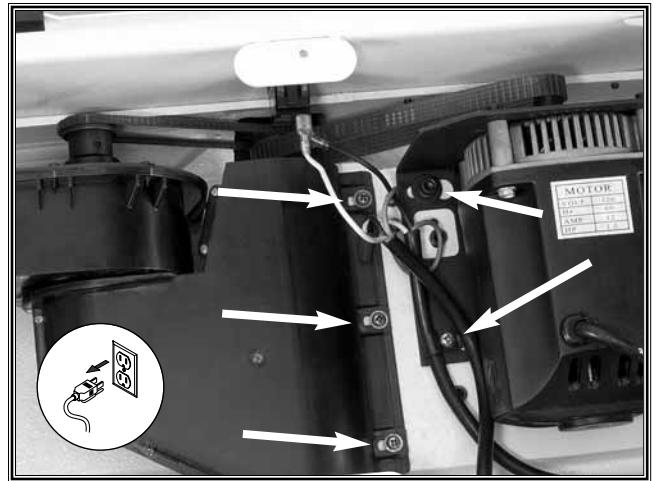

Figure 44. Motor and impeller mount plate screws.

Motor Brushes

To replace the drive belts, do these steps:

1. Lay the jointer on its side so the switch is facing up.
2. Remove the bottom cover.
3. Using a flat-head screwdriver, remove the motor brush caps (**Figure 45**).
4. Replace the motor brushes if they are damaged or severely blackened by carbon build-up.
5. Re-install the motor brush caps.
6. Replace the bottom cover.

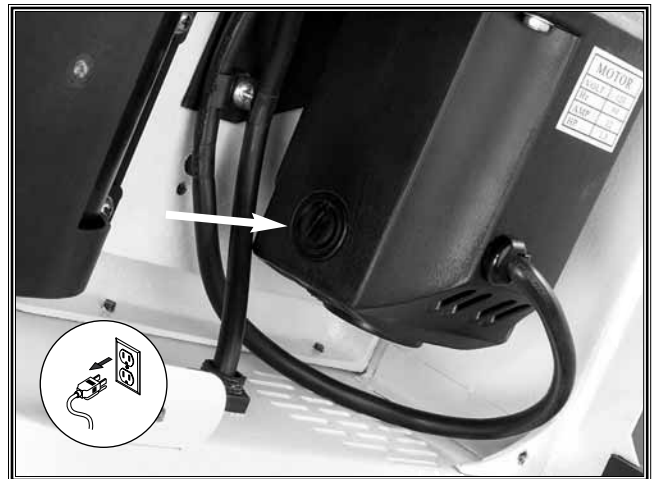

Figure 45. Motor brush caps.

Troubleshooting

SYMPTOM	POSSIBLE REASON	HOW TO REMEDY
Motor will not start and fuses or breakers blow.	<ol style="list-style-type: none"> 1. Short circuit in line cord or plug. 2. Short circuit in motor or loose connections. 3. Incorrect fuses or circuit breakers in power line. 	<ol style="list-style-type: none"> 1. Inspect cord or plug for damaged insulation and shorted wires. 2. Inspect all connections on motor for loose or shorted terminals or worn insulation. 3. Replace with correct fuses or circuit breakers.
Motor will not start.	<ol style="list-style-type: none"> 1. Voltage too low. 2. Open circuit in motor or loose connections. 	<ol style="list-style-type: none"> 1. Call an electrician to correct power line voltage. 2. Inspect all lead connections on motor for loose or open connections.
Motor overheats.	<ol style="list-style-type: none"> 1. Motor overloaded. 2. Restricted air circulation through motor. 	<ol style="list-style-type: none"> 1. Reduce load on motor. 2. Clean out motor to provide proper circulation.
Motor stalls, resulting in blown fuses or tripped breaker.	<ol style="list-style-type: none"> 1. Short circuit in motor or loose connections. 2. Voltage too low. 3. Incorrect fuses or circuit breakers in power line. 4. Motor overloaded. 	<ol style="list-style-type: none"> 1. Inspect connections on motor for loose or shorted terminals or worn insulation. 2. Call an electrician to correct power line voltage. 3. Replace with correct fuses or circuit breakers. 4. Reduce load placed on motor.
Loud, repetitious noise coming from jointer.	<ol style="list-style-type: none"> 1. Pulley setscrews or keys are missing or loose. 2. Motor fan is hitting the cover. 3. V-belt is defective. 	<ol style="list-style-type: none"> 1. Replace or tighten setscrews or keys if necessary. 2. Tighten fan or shim motor cover. 3. Replace V-belt. See page 28.
Jointer slows when operating.	<ol style="list-style-type: none"> 1. Too fast of a feed rate. 2. Too deep of cut. 	<ol style="list-style-type: none"> 1. Feed workpiece at a slower rate. 2. Decrease depth of cut.
Jointer cuts loud, overheats or bogs down in cut.	<ol style="list-style-type: none"> 1. Too deep of cut. 2. Blades are dull. 	<ol style="list-style-type: none"> 1. Decrease depth of cut. 2. Replace blades.
Gouge in the workpiece that is uneven with rest of cut (snipe).	<ol style="list-style-type: none"> 1. End of workpiece is being pressed on as it passes over the cutterhead. 2. Knives are not set at the correct height. 	<ol style="list-style-type: none"> 1. Maintain even pressure on the workpiece though the entire jointing operation. 2. Re-adjust the blade height.

Troubleshooting

SYMPTOM	POSSIBLE REASON	HOW TO REMEDY
Chipping occurs on workpiece.	<ol style="list-style-type: none"> 1. Grain direction incorrect or knots in workpiece. 2. Dull blades. 3. Too fast of a feed rate. 4. Too deep of cut. 	<ol style="list-style-type: none"> 1. Feed workpiece with the grain. Inspect workpiece for knots or try again with different workpiece. 2. Replace blades. 3. Feed the workpiece at a slower rate. 4. Decrease depth of cut.
Grain is fuzzy after jointing.	<ol style="list-style-type: none"> 1. Wood may have high moisture content. Check with moisture meter. 2. Dull blades. 3. Wood is figured or is a species that has naturally fuzzy characteristics. 	<ol style="list-style-type: none"> 1. Allow wood to dry. 2. Replace blades. 3. Use different wood or plan on extra sanding.
Lines or ridges in workpiece.	<ol style="list-style-type: none"> 1. Nicked or chipped blades. 	<ol style="list-style-type: none"> 1. Inspect blades. Replace if necessary.
Uneven blade marks on workpiece.	<ol style="list-style-type: none"> 1. One or more cutterhead blades are worn. 	<ol style="list-style-type: none"> 1. Inspect blades. Replace if necessary.
Wavy surface or chatter marks on workpiece.	<ol style="list-style-type: none"> 1. Too fast of a feed rate. 2. One or more cutterhead blades are worn. 	<ol style="list-style-type: none"> 1. Feed the workpiece at a slower rate. 2. Inspect blades. Replace if necessary.
Edge is concave or convex after edge jointing.	<ol style="list-style-type: none"> 1. Workpiece not held with even pressure on infeed and outfeed table. 2. Workpiece began too uneven. 3. Workpiece has excessive bow or twist along its length. 4. Insufficient number of passes. 5. Outfeed table not properly aligned with cutterhead. 	<ol style="list-style-type: none"> 1. Hold workpiece with even pressure as it moves through the cutterhead. See "Edge Jointing" on page 24. 2. Take partial cuts to remove extreme high spots before doing a full pass. 3. Surface plane one face so there is a good surface to position against the fence. 4. Three to five passes may be needed to achieve a perfect edge, depending on starting condition and depth of cut. 5. Set outfeed table even with cutterhead blade at top dead center. See page 18-19.

Closure

The following pages contain parts diagrams/lists and a warranty card for your SHOP FOX® Model W1694.

If you need parts or help in assembling your machine, or if you need operational information, we encourage you to call our Service Department. Our trained service technicians will be glad to help you.

If you have comments dealing specifically with this manual, please write to us using the address in the General Information. The specifications, drawings, and photographs illustrated in this manual represent the Model W1694 as supplied when the manual was prepared. However, due to Woodstock International, Inc.'s policy of continuous improvement, changes may be made at any time with no obligation on the part of Woodstock International, Inc. Whenever possible, though, we send manual updates to all owners of a particular tool or machine that have registered their purchase with our warranty card. Should you receive one, add the new information to this manual and keep it for reference.

We have included some important safety measures that are essential to this machine's operation. While most safety measures are generally universal, we remind you that each workshop is different and safety rules should be considered as they apply to your specific situation.

<p>⚠ WARNING</p> <p>As with all power tools, there is danger associated with the Model W1694. Use the tool with respect and caution to lessen the possibility of mechanical damage or operator injury. If normal safety precautions are overlooked or ignored, injury to the operator or others in the area is likely.</p>

We recommend you keep this manual for complete information regarding Woodstock International, Inc.'s warranty and return policy. Should a problem arise, we recommend that you keep your proof of purchase with your manual. If you need additional technical information relating to this machine, or if you need general assistance or replacement parts, please contact the Service Department at 1-360-734-3482 or e-mail: tech-support@woodstockint.com.

Additional information sources are necessary to realize the full potential of this machine. Trade journals, woodworking magazines, and your local library are good places to start.

The Model W1694 is specifically designed for jointing operations. **DO NOT MODIFY AND/OR USE THIS MACHINE FOR ANY OTHER PURPOSE. MODIFICATIONS OR IMPROPER USE OF THIS TOOL WILL VOID THE WARRANTY.** If you are confused about any aspect of this machine, **DO NOT** use it until all your questions have been answered.

<p>⚠ WARNING</p> <p>ALWAYS wear safety glasses or goggles when operating this machine. This machine creates the potential for flying debris, which can cause eye injury. Everyday glasses or reading glasses only have impact resistant lenses, they are not safety glasses. Be certain the safety glasses you wear meet the appropriate standards of the American National Standards Institute (ANSI).</p>		
		

W1694 Wiring Diagram

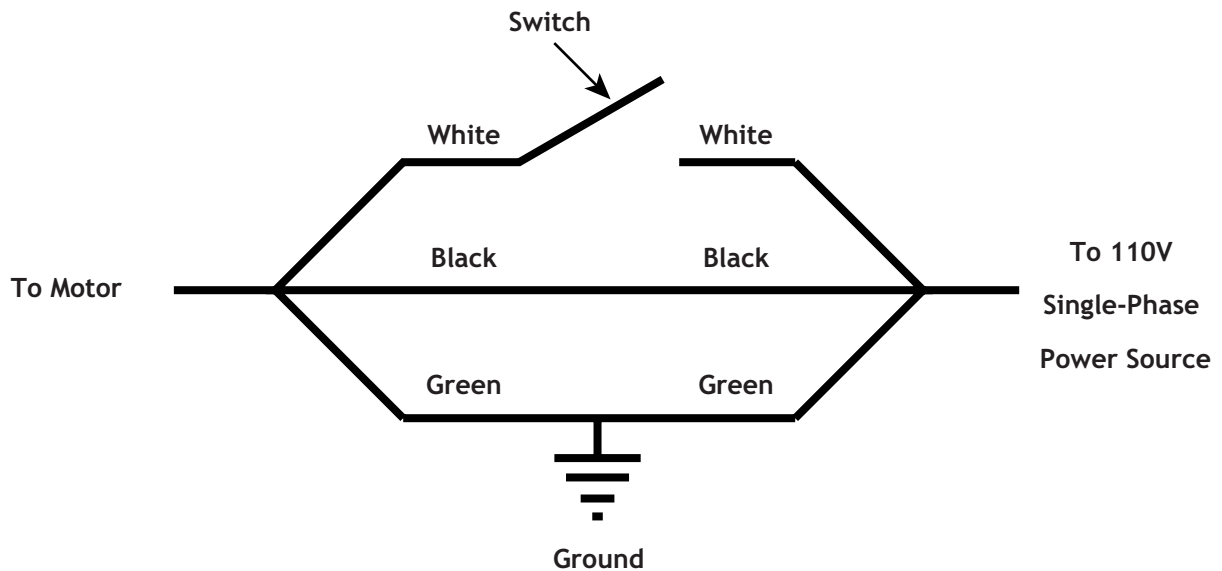

⚠ DANGER
Disconnect power before performing any electrical service. Electricity presents serious shock hazards that will result in severe personal injury and even death!

Parts

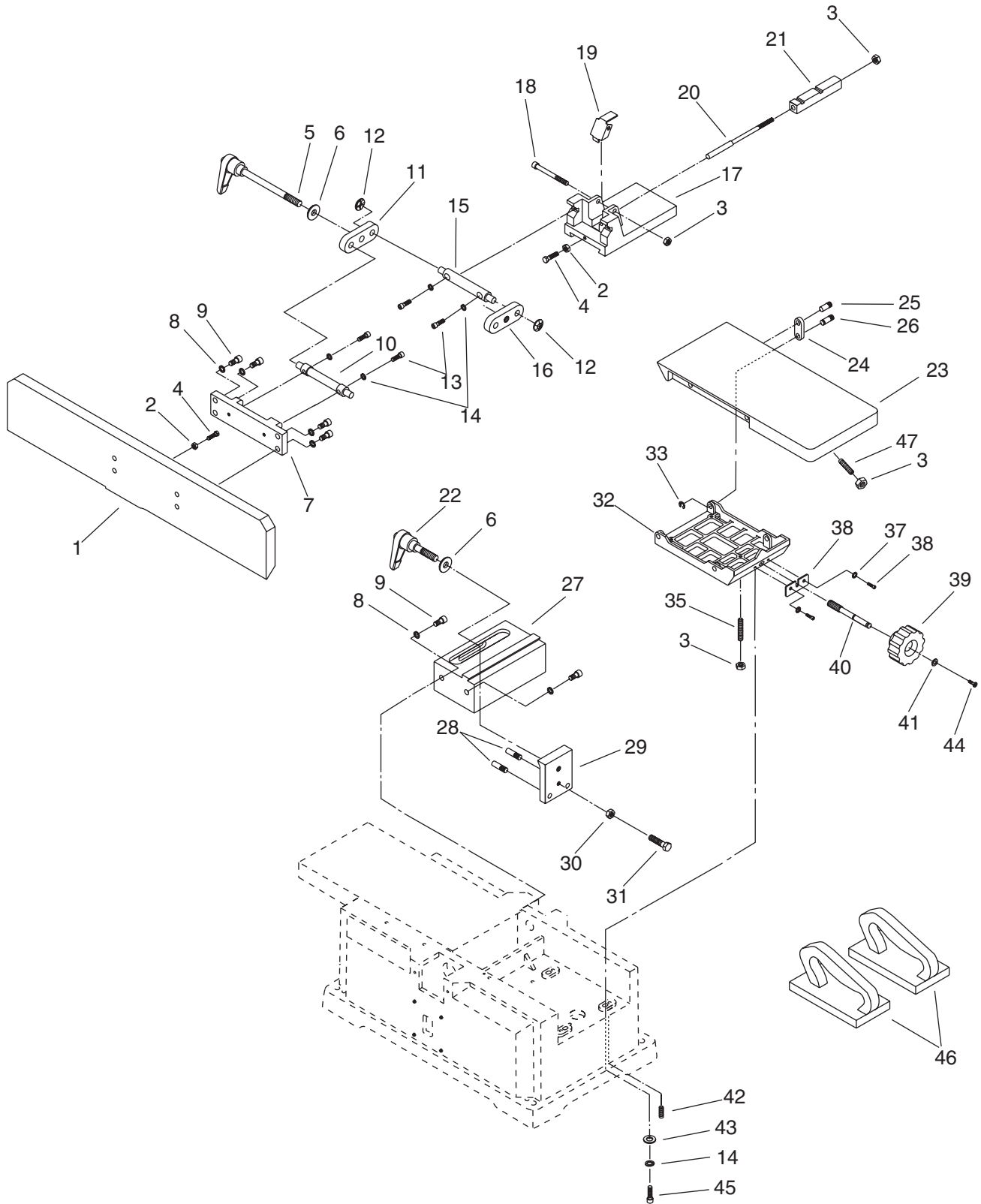

REF	PART #	DESCRIPTION
1	X1694001	FENCE
2	XPNO6M	HEX NUT M5-.8
3	XPNO1M	HEX NUT M6-1
4	XPB94M	HEX BOLT M5-.8 X 25
5	X1694005	HANDLE
6	X1694006	SPACER
7	X1694007	FENCE PLATE
8	XPLW04M	LOCK WASHER 8MM
9	XPSB14M	CAP SCREW M8-1.25 X 20
10	X1694010	PLATE SHAFT
11	X1694011	RIGHT LINK
12	X1694012	PUSH NUT M10
13	XPSB02M	CAP SCREW M6-1 X 20
14	XPLW03M	LOCK WASHER 6MM
15	X1694015	BRACKET SHAFT
16	X1694016	LEFT LINK
17	X1694017	FENCE BRACKET
18	XPSB37M	CAP SCREW M6-1 X 50
19	X1694019	LIMIT PLATE
20	X1694020	SHAFT
21	X1694021	BLOCK
22	X1694022	HANDLE
23	X1694023	INFEED TABLE
24	X1694024	BRACKET

REF	PART #	DESCRIPTION
25	X1694025	TABLE PIN
26	X1694026	FRAME PIN
27	X1694027	FENCE SUPPORT
28	X1694028	PIN
29	X1694029	LOCKING PLATE
30	XPNO3M	HEX NUT M8-1.25
31	XPB20M	HEX BOLT M8-1.25 X 35
32	X1694032	TABLE FRAME
33	X1694033	3CMI-6 E-RING
34	XPSS28M	SETSCREW M6-1 X 30
35	XPSS29M	SETSCREW M6-1 X 35
36	X1694036	SUPPORT PLATE
37	XPLW01M	LOCK WASHER 5MM
38	XPSS11M	SETSCREW M6-1 X 16
39	XPSW03-1	KNOB
40	X1694040	ELEVATION SCREW
41	XPW02M	FLAT WASHER 5MM
42	XPSS11M	SETSCREW M6-1 X 16
43	XPW03M	FLAT WASHER 6MM
44	XPS09M	PHLP HD SCR M5-.8 X 10
45	XPSB07M	CAP SCREW M6-1 X 30
46	X1694046	PUSH BLOCK (SET OF 2)
47	XPSS28M	SETSCREW M6-1 X 30

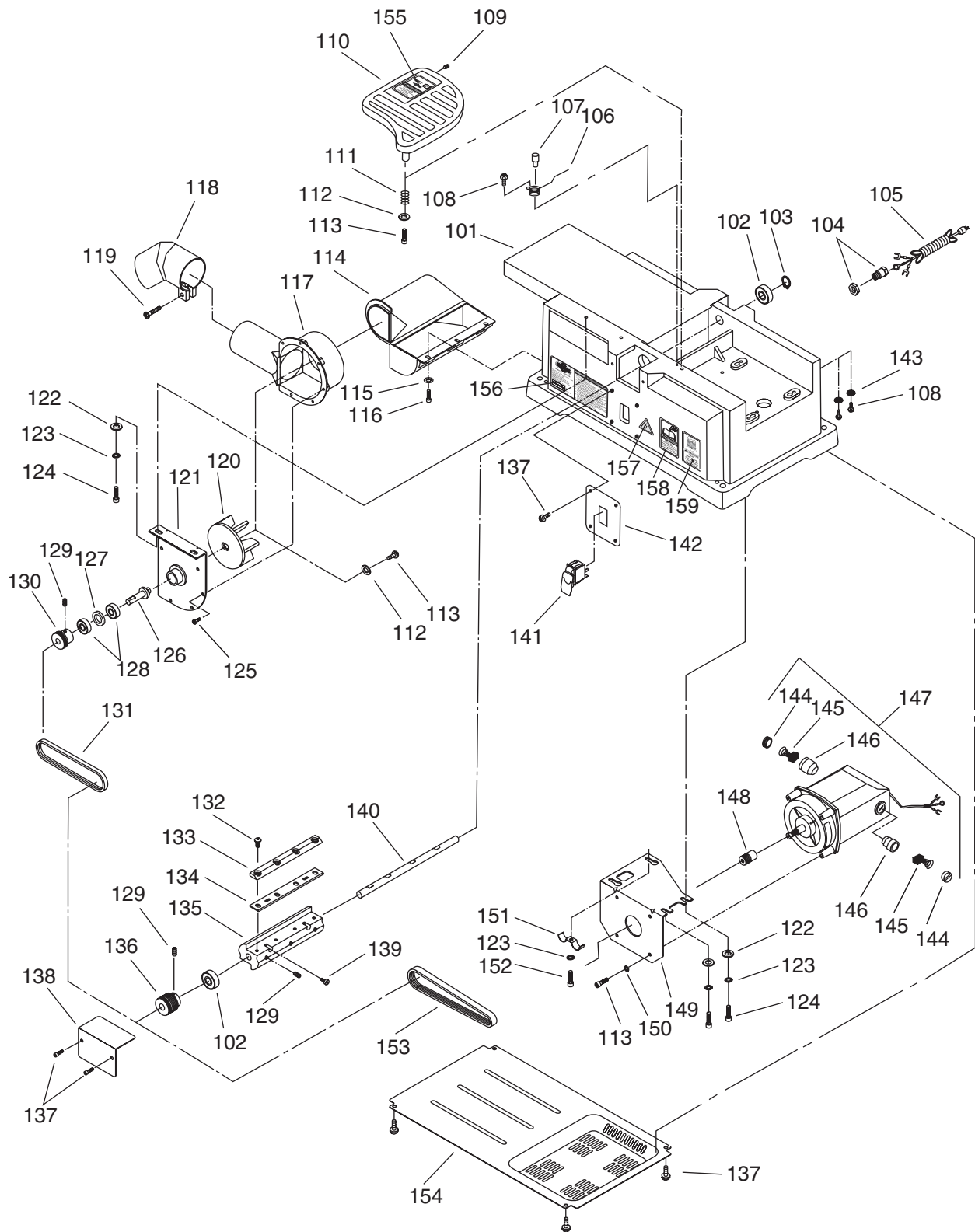

REF	PART #	DESCRIPTION
101	X1694101	BASE WITH OUTFEED TABLE
102	XP6201	BALL BEARING 6201
103	X1694103	3AMI-12 RETAINING RING
104	X1694104	STRAIN RELIEF
105	X1694105	LINE CORD
106	X1694106	SPRING
107	X1694107	PIN
108	XPS38M	PHLP HD SCR M4-.7 X 10
109	X1694109	BUMPER
110	X1694110	BLADE GUARD
111	X1694111	SPRING
112	X1694112	SPACER
113	XPSB50M	CAP SCREW M5-.8 X 10
114	X1694114	CHIP COLLECTOR
115	XPW02M	FLAT WASHER 5MM
116	XPS09M	PHLP HD SCR M5-.8 X 10
117	X1694117	CHIP EXHAUST
118	X1694118	DUST CHUTE
119	XPS26M	PHLP HD SCR M6-1 X 20
120	X1694120	IMPELLER
121	X1694121	CHIP BLOWER MOUNT PLATE
122	XPW03M	FLAT WASHER 6MM
123	XPLW03M	LOCK WASHER 6MM
124	XPSB26M	CAP SCREW M6-1 X 12
125	X1694125	THREAD FORMING SCREW
126	X1694126	FAN SHAFT
127	X1694127	SPACER
128	XP6000	BALL BEARING 6000ZZ
129	XPSS03M	SETSCREW M6-1 X 8
130	X1694130	FAN PULLEY

REF	PART #	DESCRIPTION
131	X1694131	FAN BELT
132	XPSBS02	SOCKET HD BTN SCR 1/4-20 X 5/8
133	X1694133	BLADE CLAMP
134	X1694134	BLADE (SET OF 2)
135	X1694135	CUTTERHEAD
136	X1694136	DRIVE PULLEY
137	XPS05M	PHLP HD SCR M5-.8 X 8
138	X1694138	ACCESS COVER
139	X1694139	JACK SCREW
140	X1694140	SHAFT
141	X1694141	SWITCH
142	X1694142	SWITCH PLATE
143	X1694143	SERRATED WASHER 4
144	X1694144	BRUSH CAP
145	X1694145	CARBON BRUSH (SET OF 2)
146	X1694146	BRUSH HOLDER
147	X1694147	MOTOR
148	X1694148	MOTOR PULLEY
149	X1694149	MOTOR MOUNTING PLATE
150	XPLW01M	LOCK WASHER 5MM
151	X1694151	CORD CLAMP
152	XPSB01M	CAP SCREW M6-1 X 16
153	X1694153	DRIVE BELT
154	X1694154	COVER
155	X1694155	UNPLUG JOINTER LABEL
156	X1694156	MACHINE ID/ WARNING LABEL
157	XLABEL-14	ELECTRICITY LABEL
158	X1694158	READ MANUAL LABEL
159	X1694159	GLASSES/MASK LABEL

WARRANTY CARD

Name _____
Street _____
City _____ State _____ Zip _____
Phone Number _____ E-Mail _____ FAX _____
MODEL # _____ Serial # _____

The following information is given on a voluntary basis and is strictly confidential.

- Where did you purchase your SHOP FOX® machine?

- How did you first learn about us?
____Advertisement _____Friend
____Mail order Catalog _____Local Store
____World Wide Web Site
____Other _____
- Which of the following magazines do you subscribe to.
____American Woodworker _____Today's Homeowner
____Cabinetmaker _____Wood
____Family Handyman _____Wooden Boat
____Fine Homebuilding _____Woodshop News
____Fine Woodworking _____Woodsmith
____Home Handyman _____Woodwork
____Journal of Light Construction _____Woodworker
____Old House Journal _____Woodworker's Journal
____Popular Mechanics _____Workbench
____Popular Science _____American How-To
____Popular Woodworking
____Other _____
- Which of the following woodworking/remodeling shows do you watch?
____Backyard America _____The New Yankee Workshop
____Home Time _____This Old House
____The American Woodworker _____Woodwright's Shop
____Other _____
- What is your annual household income?
____\$20,000-\$29,999 _____\$60,000-\$69,999
____\$30,000-\$39,999 _____\$70,000-\$79,999
____\$40,000-\$49,999 _____\$80,000-\$89,999
____\$50,000-\$59,999 _____\$90,000 +
- What is your age group?
____20-29 _____50-59
____30-39 _____60-69
____40-49 _____70 +
- How long have you been a woodworker?
____0 - 2 Years _____8 - 20 Years
____2 - 8 Years _____20+ Years
- How would you rank your woodworking skills?
____Simple _____Advanced
____Intermediate _____Master Craftsman
- How many SHOP FOX® machines do you own? _____
- What stationary woodworking tools do you own? Check all that apply.
____Air Compressor _____Panel Saw
____Band Saw _____Planer
____Drill Press _____Power Feeder
____Drum Sander _____Radial Arm Saw
____Dust Collector _____Lathe
____Horizontal Boring Machine _____Spindle Sander
____Jointer _____Table Saw
____Lathe _____Vacuum Veneer Press
____Mortiser _____Wide Belt Sander
____Other _____
- Which benchtop tools do you own? Check all that apply.
____1" x 42" Belt Sander _____6" - 8" Grinder
____5" - 8" Drill Press _____Mini Lathe
____8" Table Saw _____10" - 12" Thickness Planer
____8" - 10" Bandsaw _____Scroll Saw
____Disc/Belt Sander _____Spindle/Belt Sander
____Mini Jointer
____Other _____
- Which portable/hand held power tools do you own? Check all that apply.
____Belt Sander _____Orbital Sander
____Biscuit Joiner _____Palm Sander
____Circular Saw _____Portable Planer
____Detail Sander _____Saber Saw
____Drill/Driver _____Reciprocating Saw
____Miter Saw _____Router
____Other _____
- What machines/supplies would you like to see?

- What new accessories would you like Woodstock International to carry?

- Do you think your purchase represents good value?
____Yes _____No
- Would you recommend SHOP FOX® products to a friend?
____Yes _____No
- Comments: _____

CUT ALONG DOTTED LINE

FOLD ALONG DOTTED LINE

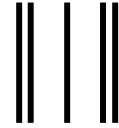
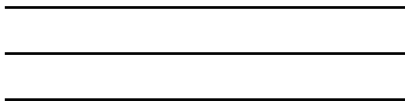

Place
Stamp
Here



WOODSTOCK INTERNATIONAL, INC.
P.O. BOX 2309
BELLINGHAM, WA 98227-2309



FOLD ALONG DOTTED LINE

TAPE ALONG EDGES--PLEASE DO NOT STAPLE

