

# Makita

アメリカ

## Power Planer

82 mm (3-1/4") MODEL 1100

### INSTRUCTION MANUAL

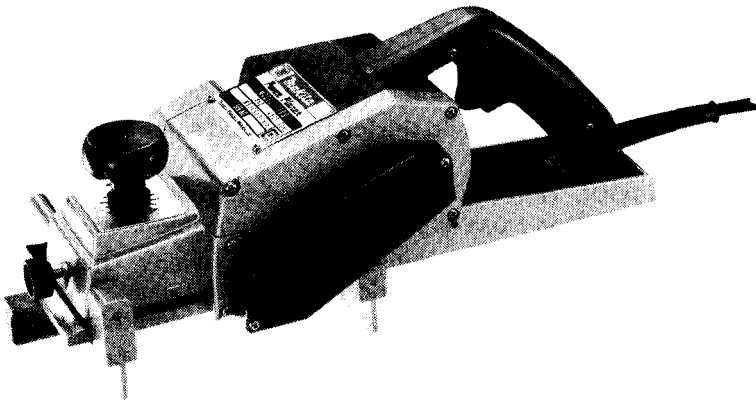

 **DOUBLE INSULATION**

#### SPECIFICATIONS

Planing width	Planing depth	Rabbeting depth	No load speed (RPM)	Overall length	Net weight
82 mm (3-1/4")	3 mm (1/8")	20 mm (3/4")	16,000	415 mm (16-3/8")	4.9 kg (10.8 lbs)

- \* Manufacturer reserves the right to change specifications without notice.
- \* Note: Specifications may differ from country to country.

# **IMPORTANT SAFETY INSTRUCTIONS**

## **(For All Tools)**

**WARNING: WHEN USING ELECTRIC TOOLS, BASIC SAFETY PRECAUTIONS SHOULD ALWAYS BE FOLLOWED TO REDUCE THE RISK OF FIRE, ELECTRIC SHOCK, AND PERSONAL INJURY, INCLUDING THE FOLLOWING:**

### **READ ALL INSTRUCTIONS.**

- 1. KEEP WORK AREA CLEAN.** Cluttered areas and benches invite injuries.
- 2. CONSIDER WORK AREA ENVIRONMENT.** Don't use power tools in damp or wet locations. Keep work area well lit. Don't expose power tools to rain. Don't use tool in presence of flammable liquids or gases.
- 3. KEEP CHILDREN AWAY.** All visitors should be kept away from work area. Don't let visitors contact tool or extension cord.
- 4. STORE IDLE TOOLS.** When not in use, tools should be stored in dry, and high or locked-up place — out of reach of children.
- 5. DON'T FORCE TOOL.** It will do the job better and safer at the rate for which it was intended.
- 6. USE RIGHT TOOL.** Don't force small tool or attachment to do the job of a heavy-duty tool. Don't use tool for purpose not intended.
- 7. DRESS PROPERLY.** Don't wear loose clothing or jewelry. They can be caught in moving parts. Rubber gloves and non-skid footwear are recommended when working outdoors. Wear protective hair covering to contain long hair.
- 8. USE SAFETY GLASSES.** Also use face or dust mask if cutting operation is dusty.
- 9. DON'T ABUSE CORD.** Never carry tool by cord or yank it to disconnect from receptacle. Keep cord from heat, oil, and sharp edges.
- 10. SECURE WORK.** Use clamps or a vise to hold work. It's safer than using your hand and it frees both hands to operate tool.
- 11. DON'T OVERREACH.** Keep proper footing and balance at all times.
- 12. MAINTAIN TOOLS WITH CARE.** Keep tools sharp and clean for better and safer performance. Follow instructions for lubricating and changing accessories. Inspect tool cords periodically and if damaged, have repaired by authorized service facility. Inspect extension cords periodically and replace if damaged. Keep handles dry, clean, and free from oil and grease.
- 13. DISCONNECT TOOLS.** When not in use, before servicing, and when changing accessories, such as blades, bits, cutters.

14. **REMOVE ADJUSTING KEYS AND WRENCHES.** Form habit of checking to see that keys and adjusting wrenches are removed from tool before turning it on.
15. **AVOID UNINTENTIONAL STARTING.** Don't carry plugged-in tool with finger on switch. Be sure switch is OFF when plugging in.
16. **OUTDOOR USE EXTENSION CORDS.** When tool is used outdoors, use only extension cords intended for use outdoors and so marked.
17. **STAY ALERT.** Watch what you are doing, use common sense. Don't operate tool when you are tired.
18. **CHECK DAMAGED PARTS.** Before further use of the tool, a guard or other part that is damaged should be carefully checked to determine that it will operate properly and perform its intended function. Check for alignment of moving parts, binding of moving parts, breakage of parts, mounting, and any other conditions that may affect its operation. A guard or other part that is damaged should be properly repaired or replaced by an authorized service center unless otherwise indicated elsewhere in this instruction manual. Have defective switches replaced by authorized service center. Don't use tool if switch does not turn it on and off.
19. **GUARD AGAINST ELECTRIC SHOCK.** Prevent body contact with grounded surfaces. For example; pipes, radiators, ranges, refrigerator enclosures.
20. **REPLACEMENT PARTS.** When servicing, use only identical replacement parts.

**VOLTAGE WARNING:** Before connecting the tool to a power source (receptacle, outlet, etc.) be sure the voltage supplied is the same as that specified on the nameplate of the tool. A power source with voltage greater than that specified for the tool can result in **SERIOUS INJURY** to the user — as well as damage to the tool. If in doubt, **DO NOT PLUG IN THE TOOL.** Using a power source with voltage less than the nameplate rating is harmful to the motor.

## **ADDITIONAL SAFETY RULES**

- 1. Rags, cloth, cord, string and the like should never be left around the work area.**
- 2. Avoid cutting nails. Inspect for and remove all nails from the workpiece before operation.**
- 3. Handle the blades very carefully.**
- 4. Be sure the blade installation bolts are securely tightened before operation.**
- 5. Hold the tool firmly with both hands.**
- 6. Keep hands away from rotating parts.**
- 7. Before using the tool on an actual workpiece, let it run for a while. Watch for vibration or wobbling that could indicate poor installation or a poorly balanced blade.**
- 8. Make sure the blade is not contacting the workpiece before the switch is turned on.**
- 9. Wait until the blade attains full speed before cutting.**
- 10. Keep at least 200 mm (8'') away from the tool at all times.**
- 11. Always switch off and wait for the blades to come to a complete stop before any adjusting.**
- 12. Never stick your finger into the chip chute. Chute may jam when cutting damp wood. Clean out chips with a stick.**
- 13. Do not leave the tool running. Operate the tool only when hand-held.**
- 14. When leaving the planer, switch off and set it with the front base up on a wooden block, so that the blades do not contact anything.**
- 15. Always change both blades or covers on the drum, otherwise the resulting imbalance will cause vibration and shorten tool life.**

**SAVE THESE INSTRUCTIONS.**

## Removing or installing mini planer blades

### CAUTION:

Always be sure that the tool is switched off and unplugged before removing or installing the blade.

To remove the blades on the drum, unscrew the three installation bolts with the socket wrench. The drum cover comes off together with the blades.

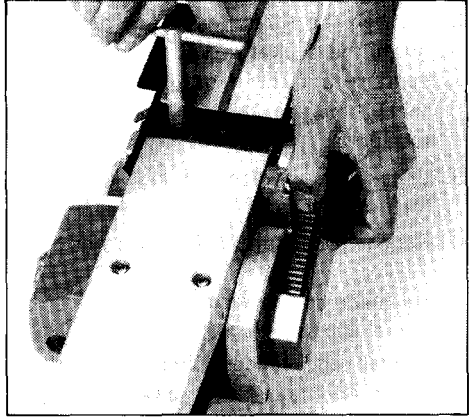

1. Remove the existing blade, if the tool has been in use, carefully clean the drum surfaces and the drum cover.
2. Loosely attach the adjust plate to the set plate with the pan head screws and set the mini planer blade on the gauge base so that the cutting edge of the blade is perfectly flush with the inside flank of the gauge plate.

3. Set the adjust plate/set plate on the gauge base so that the planer blade locating lugs on the set plate rest in the mini planer blade groove, then press in the heel of the adjust plate flush with the back side of the gauge base and tighten the pan head screws.

4. It is important that the blade sits flush with the inside flank of the gauge plate, the planer blade locating lugs sit in the blade groove and the heel of the adjust plate is flush with the back side of the gauge base. Check this alignment carefully to ensure uniform cutting.

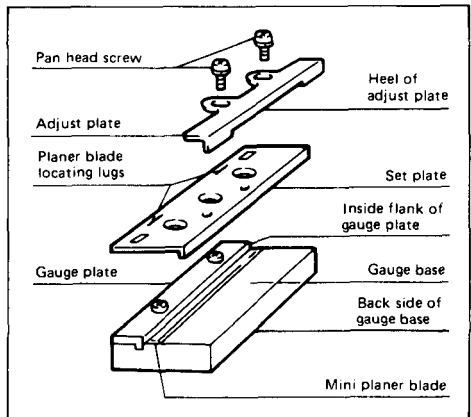

5. Slip the heel of the adjust plate into the groove of the drum.
6. Set the drum cover over the adjust plate/set plate and screw in the three hex flange head bolts so that a gap exists between the drum and the set plate to slide the mini planer blade into position. The blade will be positioned by the planer blade locating lugs on the set plate.

7. The blade's lengthwise adjustment will need to be manually positioned so that the blade ends are clear and equidistant from the housing on one side and the metal bracket on the other.
8. Tighten the three hex flange head bolts (with the socket wrench provided) and hand rotate the drum to check clearances between the blade ends and the tool body.
9. Check the three hex flange head bolts for final tightness.
10. Repeat procedures 1–9 for other blade.

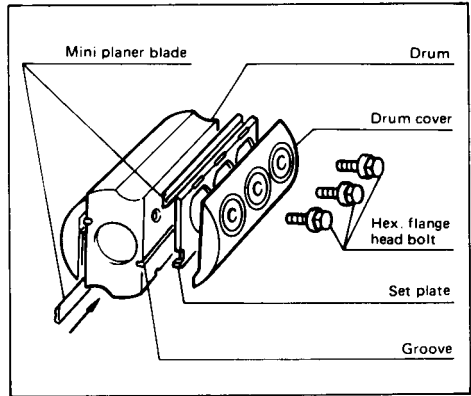

### Planer blade adjustment (optional accessory)

To install the blades, first clean out all chips or foreign matter adhering to the drum or blades. Use blades of the same dimensions and weight, or drum oscillation/vibration will result, causing poor planing action and, eventually, tool breakdown.

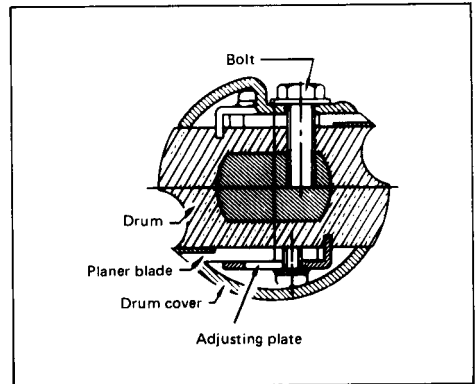

Place the blade on the gauge base so that the blade edge is perfectly flush with the inside edge of the gauge plate. Place the adjusting plate on the blade, then simply press in the heel of the adjusting plate flush with the back side of the gauge base and tighten two screws on the adjusting plate. Now slip the heel of the adjusting plate into the drum groove, then fit the drum cover on it. Tighten the three installation bolts evenly and alternately with the socket wrench.

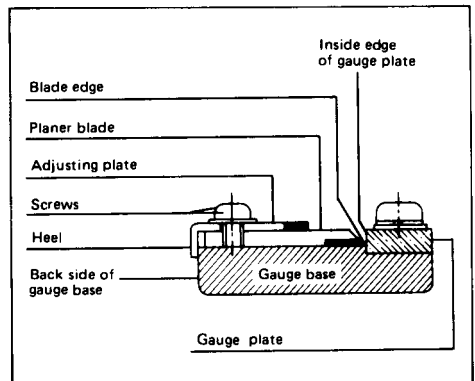

### CAUTION:

Tighten the blade installation bolts carefully when attaching the blades to the tool. A loose installation bolt can be dangerous. Always check to see they are tightened securely.

## For the correct planer blade setting

Your planing surface will end up rough and uneven, unless the blade is set properly and securely. The blade must be mounted so that the cutting edge is absolutely level, that is, parallel to the surface of the rear base. Below are some examples of proper and improper settings.

(A) Front base (Movable shoe)  
(B) Rear base (Stationary shoe)

Correct setting

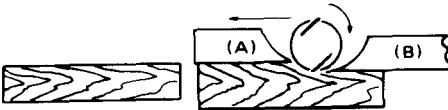

Although this side view cannot show it, the edges of the blades run perfectly parallel to the rear base surface.

Nicks in surface



Cause: One or both blades fails to have edge parallel to rear base line.

Gouging at start

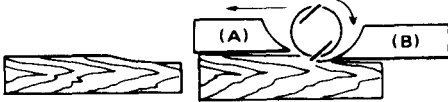

Cause: One or both blade edges fails to protrude enough in relation to rear base line.

Gouging at end

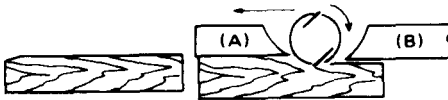

Cause: One or both blade edges protrudes too far in relation to rear base line.

## Adjusting depth of cut

Depth of cut may be adjusted by simply turning the knob on the front of the tool.

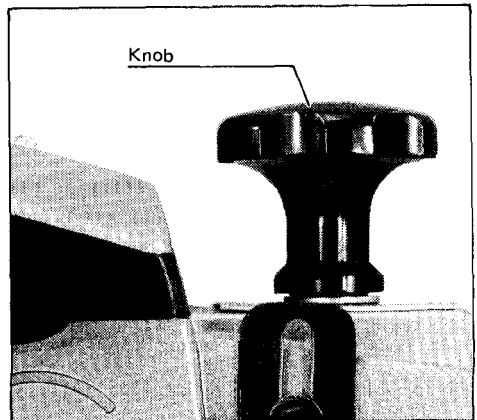

### Switch action

To start the tool, simply pull the trigger. Release the trigger to stop. For continuous operation, pull the trigger and then push in the lock button. To stop the tool from the locked position, pull the trigger fully, then release it.

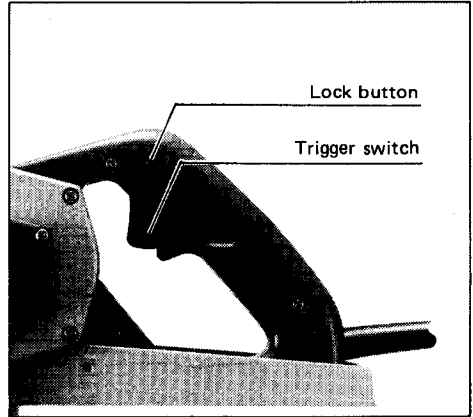

### CAUTION :

Before plugging in the tool, always check to see that the trigger switch actuates properly and returns to the "OFF" position when released.

### Planing operation

First, rest the tool front base flat upon the workpiece surface without the blades making any contact. Switch on and wait until the blades attain full speed. Then move the tool gently forward. Apply pressure on the front of tool at the start of planing, and at the back at the end of planing. Planing will be easier if you incline the workpiece in stationary fashion, so that you can plane somewhat downhill.

The speed and depth of cut determine the kind of finish. The power planer keeps cutting at a speed that will not result in jamming by chips. For rough cutting, the depth of cut can be increased, while for a good finish you should reduce the depth of cut and advance the tool more slowly.

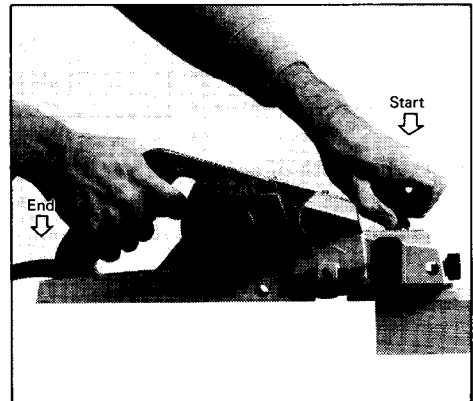



## Shiplapping

To make a stepped cut as shown at the right, use the edge fence.

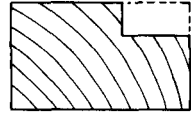

Draw a cutting line on the workpiece. Insert the edge fence into the hole in the front of the tool. Align the blade edge with the cutting line.

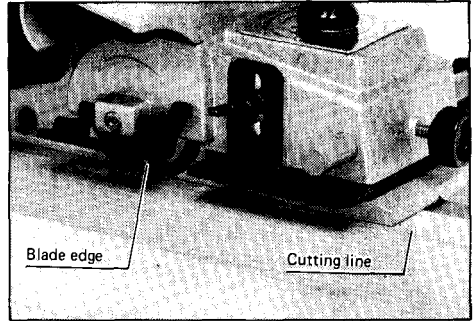

Adjust the edge fence until it comes in contact with the side of the workpiece, then secure it by tightening the screw.

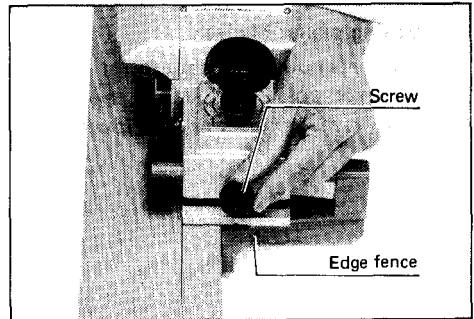

You may wish to add to the length of the fence by attaching an extra piece of wood. Convenient holes are provided in the fence for this purpose.

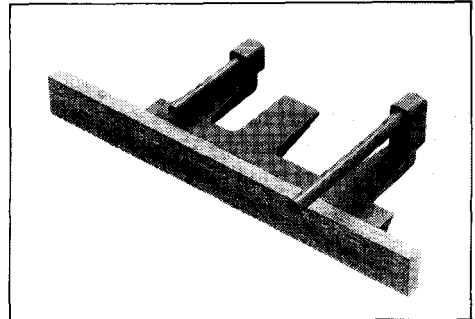

### NOTE :

When planing, move the tool with the edge fence flush with the side of the workpiece. Otherwise uneven planing may result.

Max. shiplapping depth is 20 mm (3/4").

## Chamfering

To make a cut as shown at the right, align the "V" groove in the front base with the edge of the workpiece and plane it as shown in the figure (A).

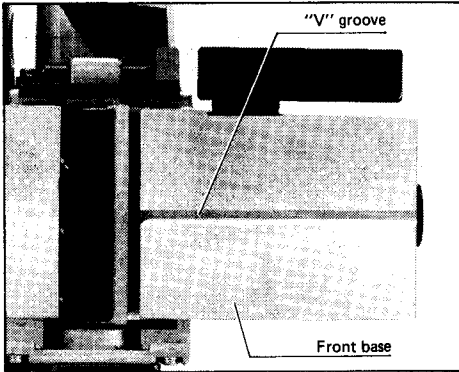
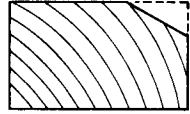

## Sharpening planer blades

Always keep your blades sharp for the best performance possible. Use the sharpening holder to remove nicks and produce a fine edge.

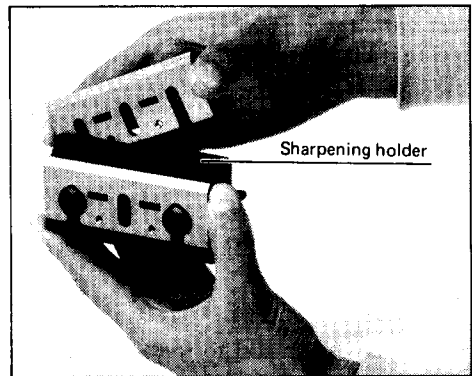

First, loosen the two wing nuts on the holder and insert the blades (A) and (B) so that they contact the sides (C) and (D). Then tighten the wing nuts.

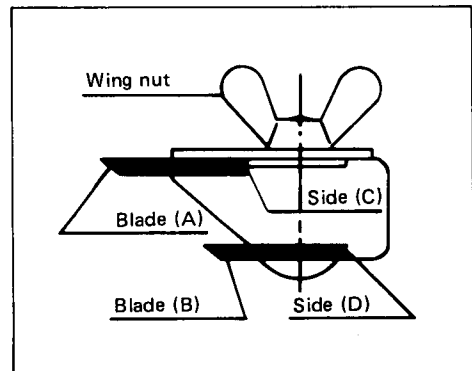

Immerse the dressing stone in water for 2 or 3 minutes before sharpening. Hold the holder so that the blades both contact the dressing stone for simultaneous sharpening at the same angle.



## MAINTENANCE

### CAUTION:

Always be sure that the tool is switched off and unplugged before attempting to perform inspection or maintenance.

### Replacing carbon brushes

Remove and check the carbon brushes regularly. Replace when they wear down to the limit mark. Keep the carbon brushes clean and free to slip in the holders. Both carbon brushes should be replaced at the same time. Use only Makita carbon brushes.

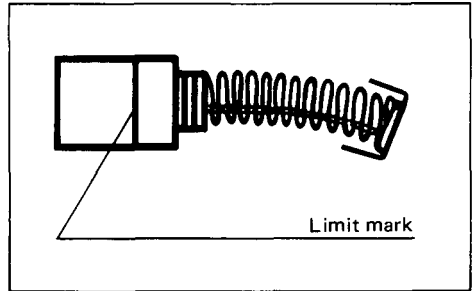

Use a screwdriver to remove the chip cover as shown in the figure.

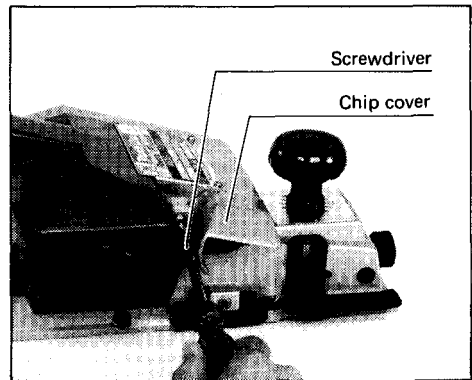

Use a screwdriver to remove the brush holder caps. Take out the worn carbon brushes, insert the new ones and secure the brush holder caps.

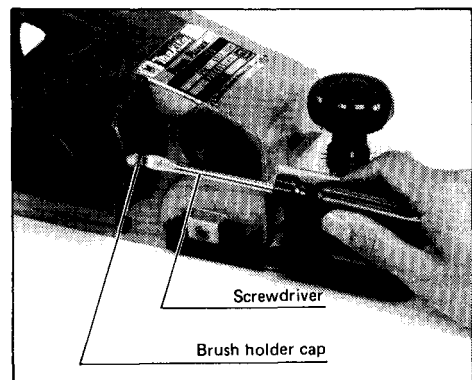

To maintain product SAFETY and RELIABILITY, repairs, any other maintenance or adjustment should be performed by Makita Authorized or Factory Service Centers, always using Makita replacement parts.

## ACCESSORIES

### CAUTION :

These accessories or attachments are recommended for use with your Makita tool specified in this manual. The use of any other accessories or attachments might present a risk of injury to persons. The accessories or attachments should be used only in the proper and intended manner.

- **Replacement blades**

Width : 82 mm (3-1/4")  
Part No. 731001-4



- **Planer blades**

(Material : Tungsten-carbide)  
Width : 82 mm (3-1/4")  
Part No. 731201-6



- **Mini planer blades**

(Material : Tungsten-carbide)  
Width : 82 mm (3-1/4")  
Part No. 793322-2  
(Use with set plate 343433-9)



- **Bevel guide**

Part No. 123032-1



- **Dressing stone**

Part No. 741802-2



- **Guide rule**

Part No. 161046-2

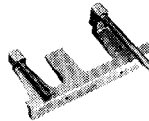

- **(+) Screwdriver**

Part No. 783002-8



- **Socket wrench**

Part No. 782209-3



- **Sharpening holder**

Part No. 123004-6

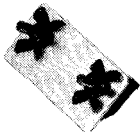

- **Blade gauge**

Part No. 123010-1



- **Hex flange hd. bolts**

Part No. 251920-3



- **Steel carrying case**

Part No. 181178-9



# 82 mm (3-1/4") POWER PLANER Model 1100

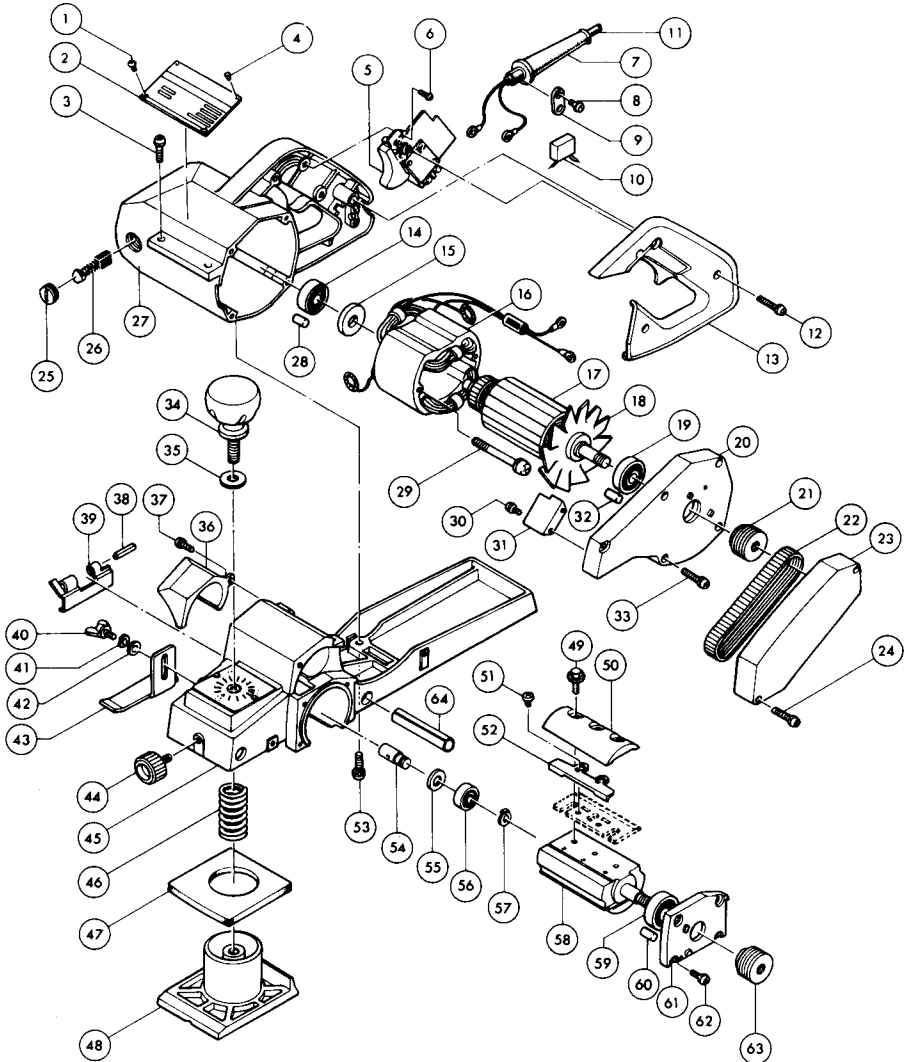

Note: The switch, noise suppressor and other part configurations may differ from country to country.

ITEM NO.	NO. USED	DESCRIPTION	ITEM NO.	NO. USED	DESCRIPTION
<u>MACHINE</u>			<u>MACHINE</u>		
1	2	Pan Head Screw M3x6 (With Washer)	33	5	Pan Head Screw M4x25 (With Washer)
2	1	Name Plate	34	1	Knob 50
3	2	Pan Head Screw M5x18 (With Washer)	35	1	Flat Washer 10
4	2	Rivet 0-5	36	1	Chip Cover
5	1	Switch	37	1	Pan Head Screw M4x20 (With Washer)
6	2	Pan Head Screw M4x6 (With Washer)	38	1	Spring Pin 4-40
7	1	Cord Guard	39	1	Drum Cover
8	2	Pan Head Screw M4x18 (With Washer)	40	1	Wing Bolt M5x10
9	1	Strain Relief	41	1	Spring Washer 5
11	1	Cord	42	1	Flat Washer 5
12	3	Pan Head Screw M4x28 (With Washer)	43	1	Depth Guide
13	1	Handle Cover	44	1	Screw M6x13
14	1	Ball Bearing 6200LB	45	1	Main Frame
15	1	Insulation Washer	46	1	Compression Spring 17
16	1	FIELD ASSEMBLY	47	1	Rubber Packing
17	1	ARMATURE ASSEMBLY (With Item 14, 15 & 17 - 19)	48	1	Front Base
18	1	Fan 80	49	6	Hex. Flange Head Bolt M6x17
19	1	Ball Bearing 6200LLB	50	2	Drum Plate
20	1	Bracket	51	4	Pan Head Screw M4x5
21	1	V-Pulley 5-26.5L	52	2	Adjust Plate
22	1	Poly V-Belt 5-285	53	2	Pan Head Screw M5x18 (With Washer)
23	1	Belt Cover	54	1	Drum Rear Shaft
24	2	Pan Head Screw M4x25 (With Washer)	55	1	Flat Washer 8
25	2	Brush Holder Cap	56	1	Ball Bearing 608ZZ
26	2	Carbon Brush	57	1	Retaining Ring S-8
27	1	Motor Housing	58	1	Drum
28	1	Rubber Pin 4	59	1	Ball Bearing 6201ZZ
29	2	Pan Head Screw M5x65 (With Washer & Bond)	60	1	Rubber Pin 8
30	2	Pan Head Screw M4x6 (With Washer)	61	1	Drum Housing
31	1	Baffle Cover	62	4	Pan Head Screw M4x14 (With Washer)
32	1	Rubber Pin 4	63	1	V-Pulley 5-29.4
			64	1	Sleeve 10

Note: The switch and other part specifications may differ from country to country.

# MAKITA LIMITED ONE YEAR WARRANTY

## Warranty Policy

Every Makita tool is thoroughly inspected and tested before leaving the factory. It is warranted to be free of defects from workmanship and materials for the period of ONE YEAR from the date of original purchase. Should any trouble develop during this one-year period, return the COMPLETE tool, freight prepaid, to one of Makita's Factory or Authorized Service Centers. If inspection shows the trouble is caused by defective workmanship or material, Makita will repair (or at our option, replace) without charge.

This Warranty does not apply where:

- repairs have been made or attempted by others;
- repairs are required because of normal wear and tear;
- The tool has been abused, misused or improperly maintained;
- alterations have been made to the tool.

IN NO EVENT SHALL MAKITA BE LIABLE FOR ANY INDIRECT, INCIDENTAL OR CONSEQUENTIAL DAMAGES FROM THE SALE OR USE OF THE PRODUCT. THIS DISCLAIMER APPLIES BOTH DURING AND AFTER THE TERM OF THIS WARRANTY.

MAKITA DISCLAIMS LIABILITY FOR ANY IMPLIED WARRANTIES, INCLUDING IMPLIED WARRANTIES OF "MERCHANTABILITY" AND "FITNESS FOR A SPECIFIC PURPOSE," AFTER THE ONE-YEAR TERM OF THIS WARRANTY.

This Warranty gives you specific legal rights, and you may also have other rights which vary from state to state. Some states do not allow the exclusion or limitation of incidental or consequential damages, so the above limitation or exclusion may not apply to you. Some states do not allow limitation on how long an implied warranty lasts, so the above limitation may not apply to you.

**Makita Corporation**

3-11-8, Sumiyoshi-cho,  
Anjo, Aichi 446 Japan

883001B063

PRINTED IN JAPAN  
1991 — 8 — N