

# Makita

アメリカ

## Planer-Jointer

312 mm (12-9/32") MODEL 2030S

### INSTRUCTION MANUAL

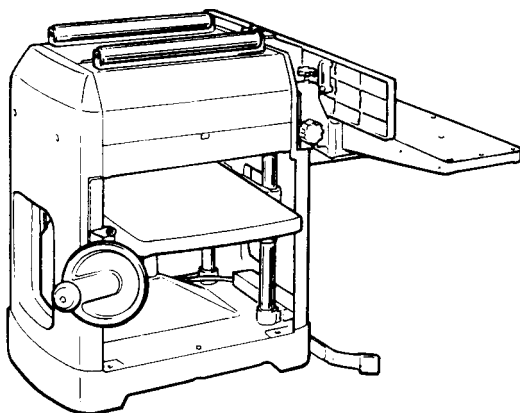

#### SPECIFICATIONS

	Cutting width (mm)	Max. cutting depth (mm)	Feed rate/min. (m)
Auto feed	312 (12-9/32")	3.0 (1/8") for stock 0 – 150 (0" – 5-29/32") wide	10.5 (34.5 ft.)
		1.5 (1/16") for stock 150 – 240 (5-29/32" – 9-7/16") wide	
		1.0 (3/64") for stock 240 – 312 (9-7/16" – 12-9/32") wide	
Manual feed	155 (6-1/8")	3.0 (1/8")	–
	Table size (mm)	Fence size (mm)	Stock height (mm)
Auto feed	290 x 500 (11-13/32" x 19-11/16")	–	4 – 160 (5/32" – 6-5/16")
Manual feed	155 x 900 (6-1/8" x 35-7/16")	615 x 100 (24-7/32" x 3-15/16")	–
No load speed (RPM)	Overall dimensions (W x L x H) (mm)		Net weight
9,000	704 x 900 x 574 (27-23/32" x 35-7/16" x 22-19/32")		44 kg (97 lbs)

\* Manufacturer reserves the right to change specifications without notice.

\* Note: Specifications may differ from country to country.

WARNING: For your personal safety, READ and UNDERSTAND before using.

SAVE THESE INSTRUCTIONS FOR FUTURE REFERENCE.

# For Your Own Safety Read Instruction Manual Before Operating Planer-Jointer

## GENERAL SAFETY PRECAUTIONS (For All Tools)

1. **KNOW YOUR POWER TOOL.** Read the owner's manual carefully. Learn the tools applications and limitations, as well as the specific potential hazards peculiar to it.
2. **KEEP GUARDS IN PLACE** and in working order.
3. **REMOVE ADJUSTING KEYS AND WRENCHES.** Form habit of checking to see that keys and adjusting wrenches are removed from tool before turning it on.
4. **KEEP WORK AREA CLEAN.** Cluttered areas and benches invite accidents.
5. **DON'T USE IN DANGEROUS ENVIRONMENT.** Don't use power tools in damp or wet locations, or expose them to rain. Keep work area well lighted.
6. **KEEP CHILDREN AWAY.** All visitors should be kept safe distance from work area.
7. **MAKE WORKSHOP KID PROOF** with padlocks, master switches, or by removing starter keys.
8. **DON'T FORCE TOOL.** It will do the job better and safer at the rate for which it was designed.
9. **USE RIGHT TOOL.** Don't force tool or attachment to do a job for which it was not designed.
10. **WEAR PROPER APPAREL.** Wear no loose clothing, gloves, neckties, rings, bracelets, or other jewelry which may get caught in moving parts. Nonslip footwear is recommended. Wear protective hair covering to contain long hair.
11. **ALWAYS USE SAFETY GLASSES.** Also use face or dust mask if cutting operation is dusty. Everyday eyeglasses only have impact resistant lenses, they are NOT safety glasses.
12. **SECURE WORK.** Use clamps or a vise to hold work when practical. It's safer than using your hand and it frees both hands to operate tool.
13. **DON'T OVERREACH.** Keep proper footing and balance at all times.
14. **MAINTAIN TOOLS WITH CARE.** Keep tools sharp and clean for best and safest performance. Follow instructions for lubricating and changing accessories.
15. **DISCONNECT TOOLS** before servicing; when changing accessories such as blades, bits, cutters, and the like.

**16. EXTENSION CORDS.** Make sure your extension cord is in good condition. When using an extension cord, be sure to use one heavy enough to carry the current your product will draw. An undersized cord will cause a drop in line voltage resulting in loss of power and overheating. Table 1 shows the correct size to use depending on cord length and nameplate ampere rating. If in doubt, use the next heavier gage. The smaller the gage number, the heavier the cord.

Ampere Rating		Minimum gage for cord <sup>a</sup>				
		Volts	Total length of cord in feet			
		120 V	25 ft.	50 ft.	100 ft.	150 ft.
		240 V	50 ft.	100 ft.	200 ft.	300 ft.
More Than	Not More Than	AWG				
0	6		18	16	16	14
6	10		18	16	14	12
10	12		16	16	14	12
12	16		14	12	Not Recommended	

<sup>a</sup> Only the applicable parts of the Table need to be included. For instance, a 120-volt product need not include the 240-volt heading.

- 17. REDUCE THE RISK OF UNINTENTIONAL STARTING.** Make sure switch is in off position before plugging in.
- 18. USE RECOMMENDED ACCESSORIES.** Consult the owner’s manual for recommended accessories. The use of improper accessories may cause risk of injury to persons.
- 19. NEVER STAND ON TOOL.** Serious injury could occur if the tool is tipped or if the cutting tool is accidentally contacted.
- 20. CHECK DAMAGED PARTS.** Before further use of the tool, a guard or other part that is damaged should be carefully checked to determine that it will operate properly and perform its intended function — check for alignment of moving parts, binding of moving parts, breakage of parts, mounting, and any other conditions that may affect its operation. A guard or other part that is damaged should be properly repaired or replaced.
- 21. DIRECTION OF FEED.** Feed work into a blade or cutter against the direction of rotation of the blade or cutter only.
- 22. NEVER LEAVE TOOL RUNNING UNATTENDED. TURN POWER OFF.** Don’t leave tool until it comes to a complete stop.
- 23. PROPER GROUNDING.** This tool should be grounded while in use to protect the operator from electric shock.
- 24. POLARIZED PLUGS.** To reduce the risk of electric shock, this equipment has a polarized plug (one blade is wider than the other). This plug will fit in a polarized outlet only one way. If the plug does not fit fully in the outlet, reverse the plug. If it still does not fit, contact a qualified electrician to install the proper outlet. Do not change the plug in any way.

**VOLTAGE WARNING:** Before connecting the tool to a power source (receptacle, outlet, etc.) be sure the voltage supplied is the same as that specified on the nameplate of the tool. A power source with voltage greater than that specified for the tool can result in **SERIOUS INJURY** to the user — as well as damage to the tool. If in doubt, **DO NOT PLUG IN THE TOOL**. Using a power source with voltage less than the nameplate rating is harmful to the motor.

## **ADDITIONAL SAFETY RULES FOR JOINTER & AUTO-PLANER**

1. Don't use the tool in presence of flammable liquids or gases.
2. Handle the blades very carefully.
3. Check the blades carefully for cracks or damage before operation. Replace cracked or damaged blades immediately.
4. Be sure the planer blade installation bolts are securely tightened before operating.
5. Sharpen both blades evenly, or replace both blades or both cutterhead covers at the same time.
6. Remove nails and clean the workpiece before cutting. Nail, sand or other matter can cause blade damage.
7. Make sure the blade is not contacting workpiece before the switch is turned on.
8. Wait until the blades attain full speed before cutting.
9. Keep hands away from rotating parts.
10. Stop operation immediately if you notice anything abnormal.
11. Always switch off and wait for blades to come to a complete stop before adjusting any parts, cleaning out chips or approaching the blade.
12. Never stick your finger into the chip chute. Chute may jam when cutting damp wood. Turn off the planer-jointer and then clean out chips with a stick.
13. Do not touch blades right after operation, they may be extremely hot and could burn your skin.
14. Don't abuse cord. Never yank cord to disconnect from receptacle. Keep cord from heat, oil and sharp edges.
15. Do not use auto-planer and jointer at the same time. Overloading of the motor can occur.

## FOR JOINTER

1. Maintain the proper relationships of infeed and outfeed table surfaces and cutterhead blade path.
2. Do not perform jointing operations on material shorter than 140 mm (5-1/2 inches), narrower than 19 mm (3/4 inch), or less than 12.7 mm (1/2 inch) thick.
3. Do not perform planing operations on material shorter than 140 mm (5-1/2 inches), narrower than 19 mm (3/4 inch), wider than 155 mm (6-1/8 inches) or thinner than 12.7 mm (1/2 inch).
4. Support the workpiece adequately at all times during operation; maintain control of the work at all times.
5. Do not back the work toward the infeed table.
6. Do not attempt to perform an abnormal or little-used operation without study and the use of adequate hold-down/push blocks, jigs, fixtures, stops and the like.

## FOR AUTO-PLANER

1. Two or more pieces of narrow but similar thickness stock can be passed through the auto-planer side by side.  
However, allow some spacing between the stock to permit the feed rollers to grip the thinnest piece.  
Otherwise, a slightly thinner piece could be kicked back by the cutterhead.
2. Determine the depth of cut according to the table shown on the front of the tool. Do not attempt to cut more than the specified amount in one pass.

## WARNING

For Your Own Safety, Read Instruction Manual Before Operating Jointer

1. Wear eye protection.
2. Never perform jointing or planing operation with cutter head or drive guard removed.
3. Never make jointing or planing cut deeper than 3 mm (1/8 inch).
4. Always use hold-down/push blocks for jointing material narrower than 76.2 mm (3 inches), or planing material thinner than 76.2 mm (3 inches).

**SAVE THESE INSTRUCTIONS.**

### **Movement and transport of planer-jointer**

When moving the tool, hold it as shown in the figure. When transporting it by vehicle, secure with a rope or other substantial means to prevent tipping or movement.

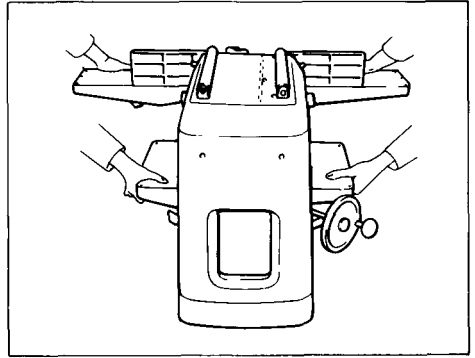

### **Positioning the planer-jointer**

Locate the tool in a well lit and level place where you can maintain good footing and balance. Bolt it to the workbench using the bolt holes provided in the base.

When locating it without bolting, use the stays provided to help maintain its stability. Remove the two bolts which secure the stays. Extend the stays by one bolt hole and secure them using the bolts.

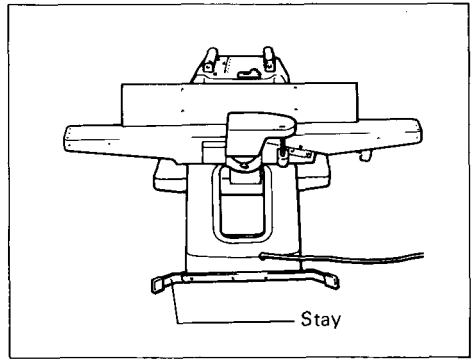

### **Installing the crank handle**

Install the crank handle using the socket wrench provided.

### **Switch action**

#### **CAUTION:**

Before plugging in the tool, always be sure that the tool is switched off.

To start the tool, insert the key and press the ON side of the switch. To stop it, press the OFF side.

#### **CAUTION:**

When not using the tool, remove the key and store it in a secure place. This prevents unauthorized operation.

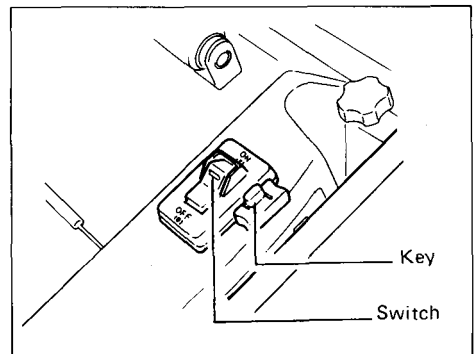

## AUTO-PLANER FUNCTIONS:

### Dimensional adjustment

Raise the table by turning the crank handle clockwise until the indicator plate points to the scale graduation indicating the desired finished dimension. One full turn of the crank handle moves the table 2 mm ( $3/32''$ ) up or down. The scale has inch graduations on its right side and metric graduations on its left side.

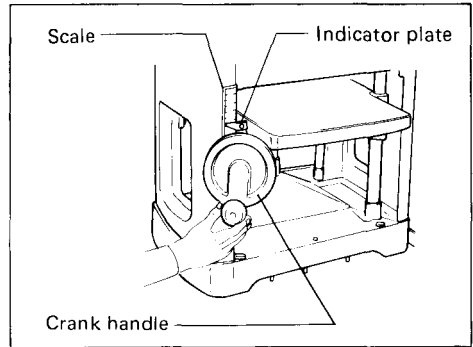

### Adjusting the depth of cut

The maximum depth of cut differs depending upon the width of workpiece being cut. Refer to the table at right. When you wish to cut deeper than the amount specified in the table, make two or more passes to avoid overloading the motor, jamming the workpiece and subsequent damage. To adjust the depth of cut, proceed as follows.

Insert the workpiece flat on the infeed table top. Raise the table by turning the crank handle clockwise. The depth gauge will rise and the amount of gauge rise indicates the depth of cut.

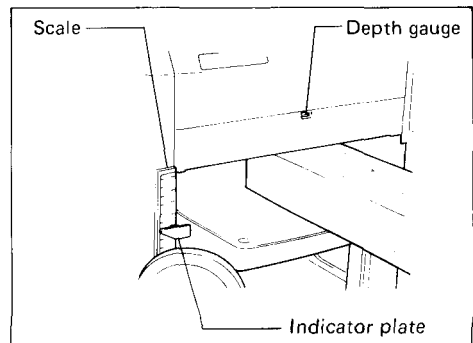
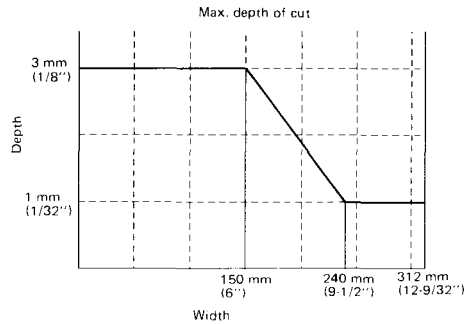

### CAUTION:

- Always raise the table when aligning the indicator plate with the graduation indicating the desired finished dimension. If the table is lowered into the desired finished dimension, additional play in the screw may result. This may cause an undesired finished dimension, gouging or sniping of the workpiece.
- Always place the workpiece flat on the infeed table top when predetermining the depth of cut. Otherwise, the predetermined depth of cut will differ from actual depth of cut.

**Operation**

Determine the depth of cut as described before. Insert the workpiece flat on the table top. When cutting a long or heavy workpiece, lift up its end slightly at the start and the end of the cut to avoid gouging or sniping at the extreme ends of the workpiece.

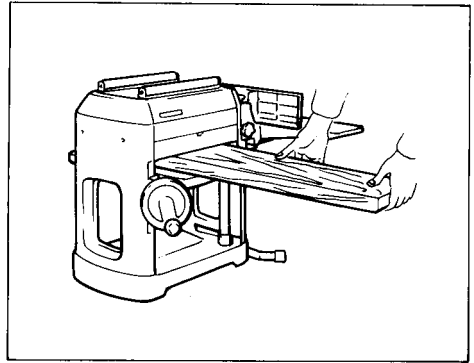

Two rollers are provided on top of the tool to enable quick, effortless return of the workpiece to the infeed table side. This is especially convenient with two operators.

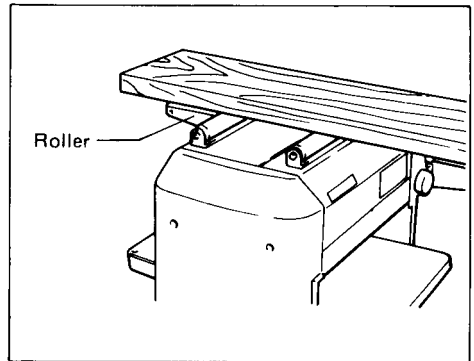

**CAUTION:**

- Workpieces with the following dimensions cannot be fed into the auto-planer because the interval between the two feed rollers is 114 mm (4-1/2"). Do not try to cut them.

1		Less than 115 mm (4-1/2") long.
2		Having a groove more than 115 mm (4-1/2") wide.
3		Having grooves at intervals of 115 mm (4-1/2").

- Stop the tool when the workpiece has stalled. Allowing the tool to run with a stalled workpiece causes rapid wearing of the feed rollers.



## JOINTER FUNCTIONS:

### Extension support table

The extension support table is convenient for cutting long workpieces. Install it on the outfeed table and semi-tighten the four hex bolts. Extend the legs and hook the arms over the screw using the hook (A). Then tighten the screws securely. Adjust the table height using the knobs so that the extension support table is level with the outfeed table. Then tighten the wing nuts securely. After adjusting the table height, tighten the four hex bolts securely.

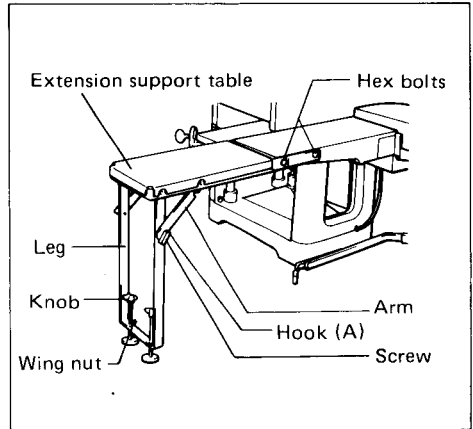

When moving the tool, fold the extension support table as follows.

First fold the extension support table as shown in the figure. Tighten the two hex bolts securely. While holding the legs, loosen the screws and unhook the arms from the screw. Fold the legs and hook the arms over the screw using the hook (B). Then tighten the screws securely.

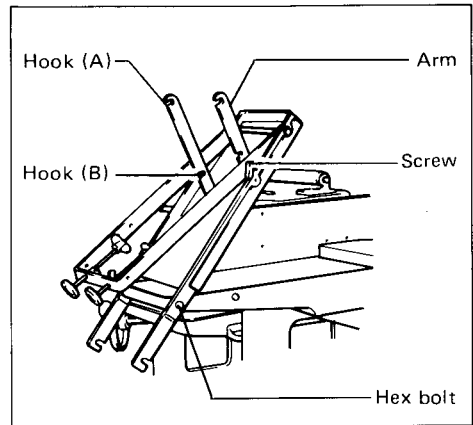

### Adjusting the depth of cut

The depth of cut can be adjusted from 0 mm to 3 mm (1/8"). Align the pointer to the desired graduation on the scale plate by turning the depth adjusting knob. The in-feed table is lowered for increased depth of cut by turning it clockwise and raised by turning it counterclockwise.

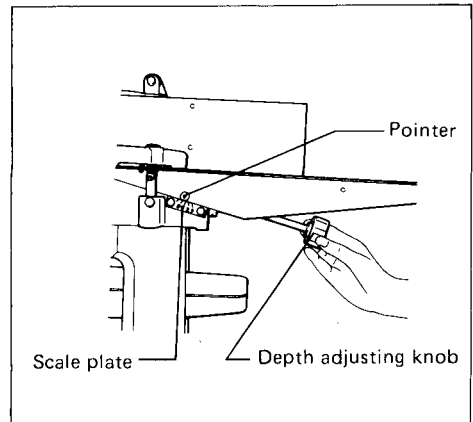

### Adjusting the fence angle

The fence angle can be adjusted at any angle from 0° to 45°. Loosen the clamp screws (A) and (B) and pull the fence out slightly. Then tighten the clamp screws (A) and (B). Loosen the hex bolts (A) and (B) and tilt the fence according to your work. Then tighten the hex bolts (A) and (B) securely.

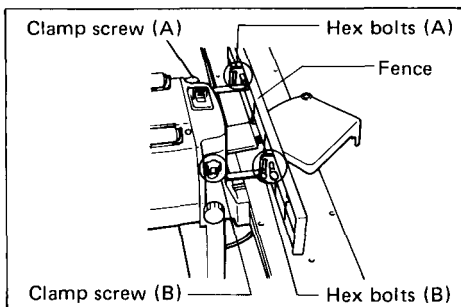

### Operation

#### Placement of hands during feeding

At the start of the cut, the left hand holds the workpiece firmly down on the infeed table and firmly against the fence. The right hand pushes the workpiece toward the blades. After the cut has started, the new surface rests firmly on the outfeed table. The left hand should press down on this part well away from directly over the cutterhead, at the same time maintaining flush contact with the fence. The right hand presses the workpiece forward and before the right hand passes over the cutterhead it should be cautiously moved to the workpiece on the outfeed table.

#### Jointing an edge

Set the fence square with the table. Hold the best face of the workpiece firmly against the fence throughout the feed. Side pressure is required to keep the workpiece in flush contact with the fence. This is very important when jointing wide workpiece.

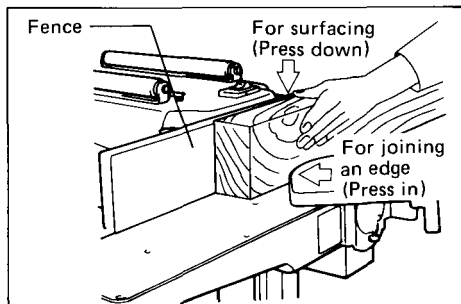

#### Surfacing

For surfacing, press the workpiece down against the outfeed table. Surfacing or planing a wide work surface on a warped or twisted board is very difficult to accomplish. Hold-down/push blocks be useful in all cases. They should always be used when surfacing workpieces thinner than 76.2 mm (3"). If the workpiece is warped , joint the dished (hollow, concave) surface first, whenever possible. Small depths of cut only should be taken whenever surfacing warped workpieces.

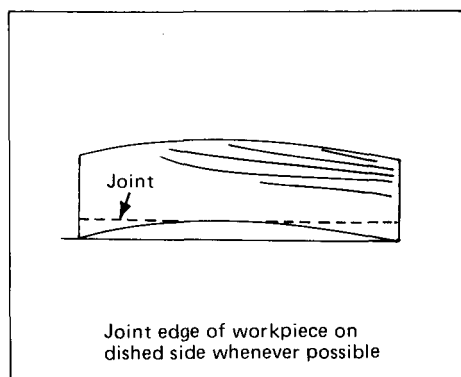

## **Beveling**

To cut a bevel, set the fence at the required angle and run the workpiece across the blades while keeping it firmly against the fence and tables. Carefully maintain flush, steady contact with the fence while making the cut.

## **REPLACING THE PLANER BLADES**

Dull blades can cause a rough finish, an overload of the motor and dangerous kickback of the workpiece. Sharpen or replace dull blades immediately. This tool is equipped with either throw-away blades or standard blades. The method of replacing the blades differs depending upon the type of the blade. Follow the correct method for your tool.

### **CAUTION:**

- Always be sure that the tool is switched off and unplugged before removing or installing the blades.
- Handle the blades very carefully when removing or installing the blades to prevent cuts or injury from the blades and to prevent damage to the blades. They are razor-sharp.
- Clean out all chips, dust, pitch or foreign matter adhering to the drum or blades before installing the blades.
- Use blades of the same dimensions and weight, or drum oscillation/vibration will result, causing poor cutting action and, eventually, tool breakdown.
- Replace both blades at the same time.
- The throw-away blade has a cutting edge on both sides. When one cutting edge becomes dull, you can use the other cutting edge. Always remove resin and dirt sticking to the reverse side of the blade before using the other cutting edge. This blade must not be re-sharpened. When both cutting edges become dull, the blade should be carefully thrown away.

## AUTO-PLANER

### 1. Removing the blades

Loosen the hex bolt which secures the chip cover and open the chip cover. Open the safety cover over the jointer and rotate the drum by turning the knob until the drum can be locked in the position whereby the blade installation bolts face upward.

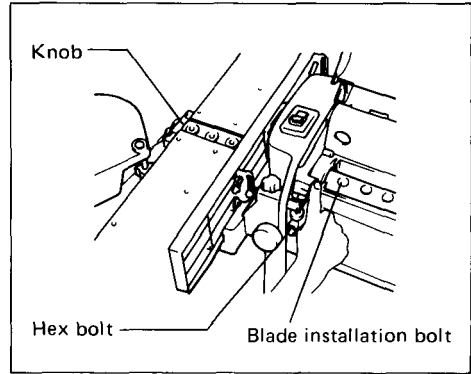

The magnetic holder has a different shaped claw on each side. Use the correct claw for auto-planer.

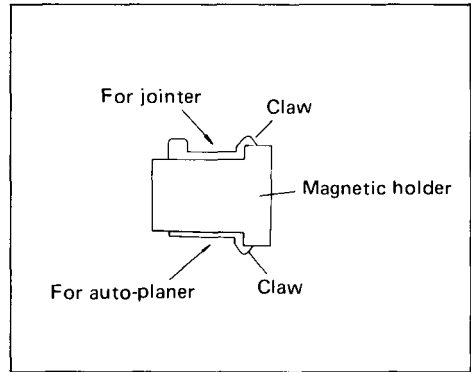

Place the two magnetic holders on the set plate and push them in the direction of the arrow until the claw contacts the blade. Remove the eight blade installation bolts using the socket wrench. Grip the magnetic holders and raise them straight up to remove the set plate and blade from the drum. Press the lock plate and rotate the drum by turning the knob 180° to lock the drum. Remove the other blade as described above.

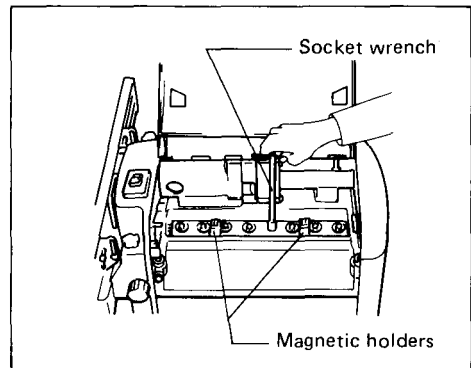
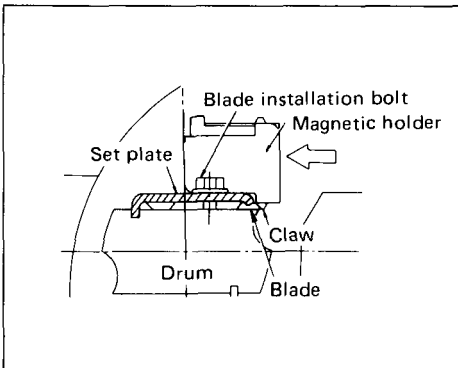

## 2. Installing the blades

Provide a flat wood block approx. 300 mm (11-13/16") long and 100 mm (3-15/16") wide. Place the blade and set plate on the wood block so that the blade locating lug of the set plate rests in the groove of the blade. Adjust the set plate so that both ends of the blade protrude approx. 1 mm (3/64") beyond the end of the set plate. Place the two magnetic holders on the set plate and push them until the claw contacts the blade (Note: Use the correct claw for auto-planer.)

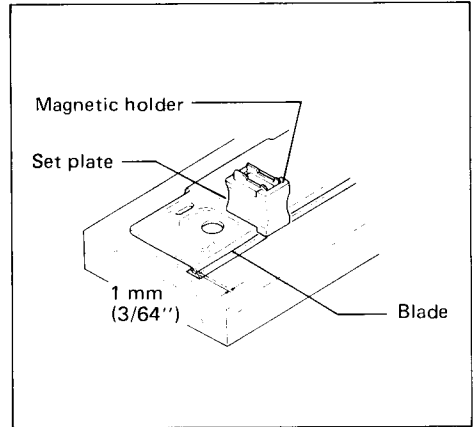

Grip the magnetic holders and slip the heel of the set plate into the groove in the drum. Install the blade installation bolts.

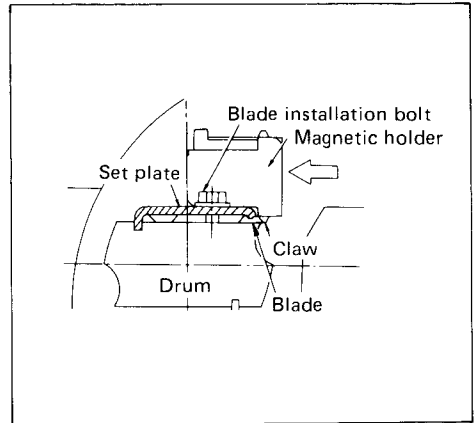

After tightening all the blade installation bolts lightly and evenly from the center to the outside, tighten them completely following the same sequence. Remove the magnetic holders from the set plate.

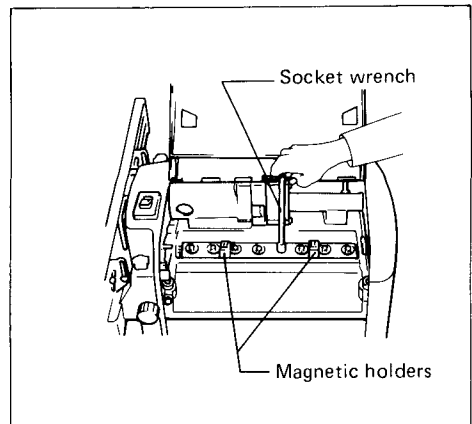

Install the other blade as described above. Rotate the drum slowly while pressing the lock plate to make sure there is nothing abnormal. Then close the chip cover and secure using the hex bolt.

**CAUTION:**

- Do not tighten the blade installation bolts without the blade locating lug of the set plate correctly resting in the groove of the blade. This may cause damage to the blade and potential injury to the operator.
- Tighten the blade installation bolts securely when installing the blades.  
Do not turn the tool on with the chip cover open.

## JOINTER

### 1. Removing the blades

#### CAUTION:

Always close the chip cover over the auto-planer before removing the blade.

Lower the infeed table fully by turning the depth adjusting knob clockwise. Loosen the hex bolt which secures the safety cover rod and lift off the safety cover. Set the fence angle at  $0^\circ$  and push the fence fully toward the auto-planer. Pull the lock pin and rotate the drum by turning the knob to lock the drum in the position whereby the blade installation bolts face upward.

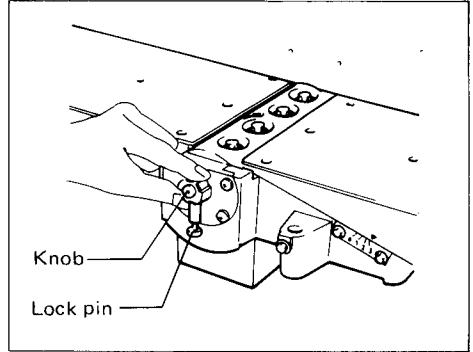

#### (NOTE)

The drum can be locked in two different positions. One position is where the blade edge faces upward and the other is where the blade installation bolts face upward.

Remove the four blade installation bolts and the drum plate. Place the two magnetic holders on the set plate. (Note: The magnetic holder has a different shaped claw on each side. Use the correct claw for jointer.) Push them in the direction of the arrow until the claw contact the blade.

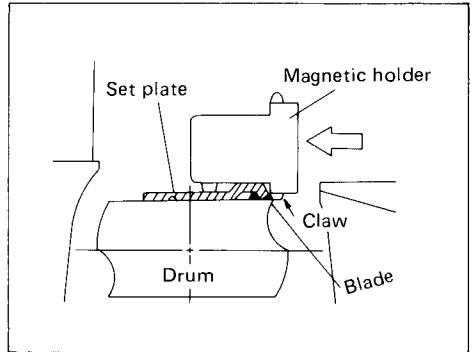

Grip the magnetic holders and raise them to remove the set plate and blade from the drum. Pull the lock pin and rotate the drum by turning the knob  $180^\circ$  to lock the drum. Remove the other blade as described above.

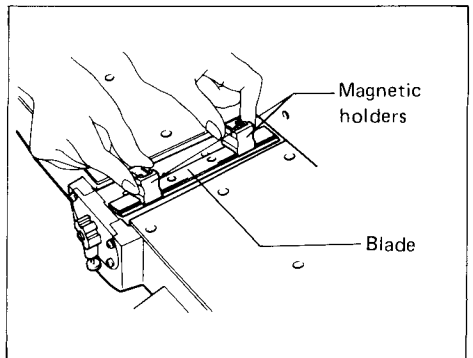

## 2. Installing the blades

Provide a flat wood block approx. 150 mm (5-29/32") long and 100 mm (3-15/16") wide. Place the blade and set plate on the wood block so that the blade locating lug of the set plate rests in the groove of the blade. Adjust the set plate so that both ends of the blade do not protrude from the ends of the set plate. Place the two magnetic holders on the set plate and push them until the claw contacts the blade. (Note: Use the correct claw for jointer.)

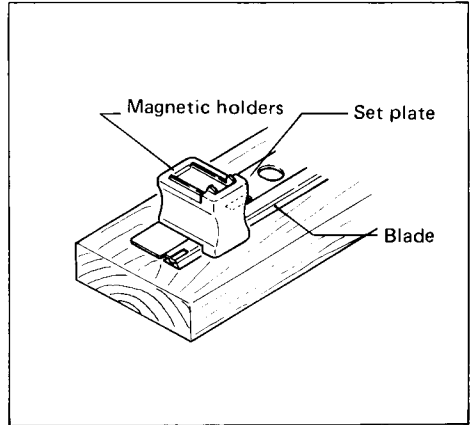

Lock the drum in the position whereby the blade installation bolts face upward. Place the set plate and blade on the drum so that the heads of the depth adjusting screws in the drum fit into the square holes in the set plate. Remove the magnetic holders while holding the set plate with your hand.

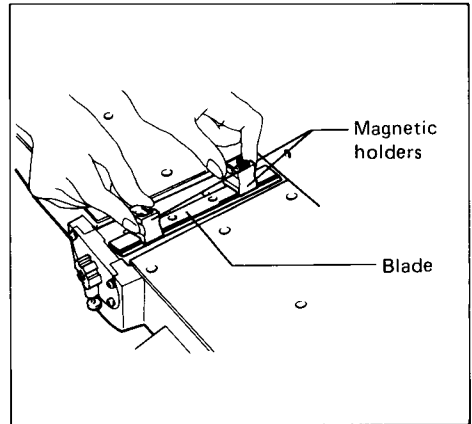

Place the drum plate on the set plate. Install the blade installation bolts and semi-tighten them.

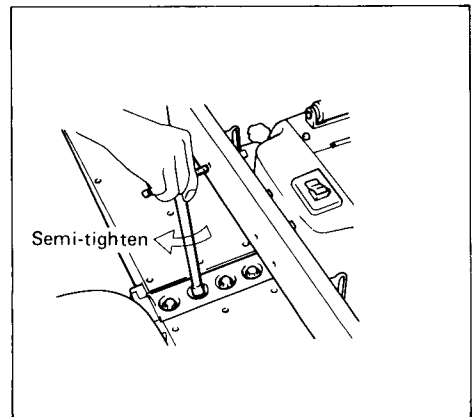



Lock the drum in the position whereby the blade edge faces upward. Place the triangular rule flat on the outfeed table. Turn the adjusting screws until the blade edge just contacts the triangular rule. After adjusting both adjusting screws, pull the lock pin to unlock the drum. Rotate the drum by turning the knob clockwise to make sure the blade protrusion is at exactly the same height all the way across. If not, adjust the adjusting screws again.

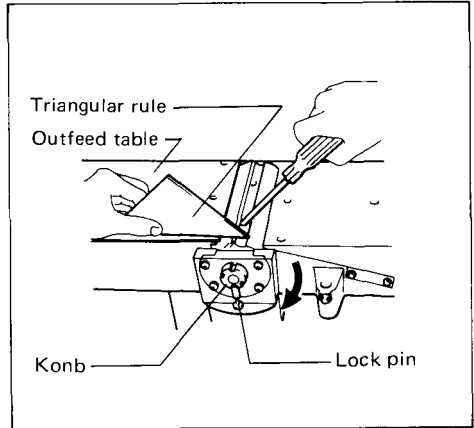

After carefully adjusting the blade protrusion, lock the drum in the position whereby the blade installation bolts face upward. Securely tighten the blade installation bolts evenly from the center of the outside.

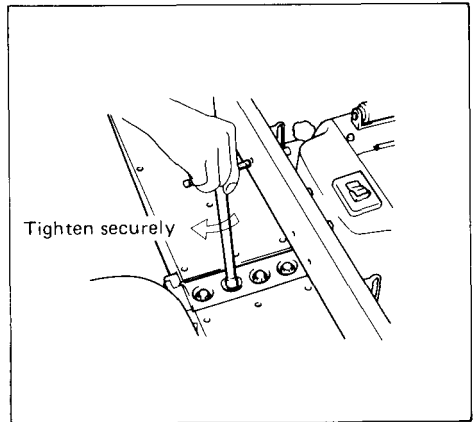

Then slightly retighten the adjusting screws by turning clockwise.

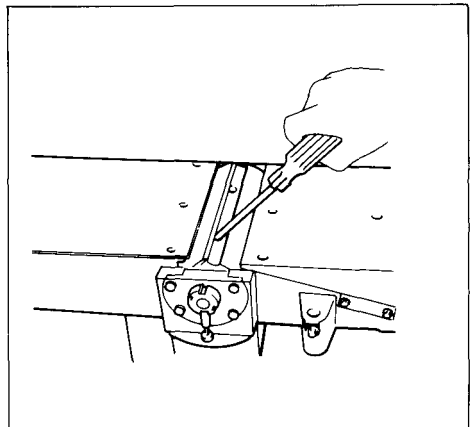

Install the other blade as described above. Re-install the safety cover in its original position and be sure that the safety cover works properly and briskly.

**CAUTION:**

- Do not tighten the blade installation bolts without the blade locating lug of the set plate correctly resting in the groove of the blade. This may cause damage to the blade and potential injury to the operator.
- Tighten the blade installation bolts securely when installing the blades.
- Always be sure that the drum is unlocked after installing the blades.

## REMOVING OR INSTALLING THE JOINTER

### CAUTION:

Always be sure that the tool is switched off and unplugged before removing or installing the jointer.

The jointer can be easily removed from the auto-planer. You can carry it by yourself.

### 1. Removing the jointer

Loosen the right and left knobs. Pull the jointer toward you as shown in the figure. The jointer can be removed.

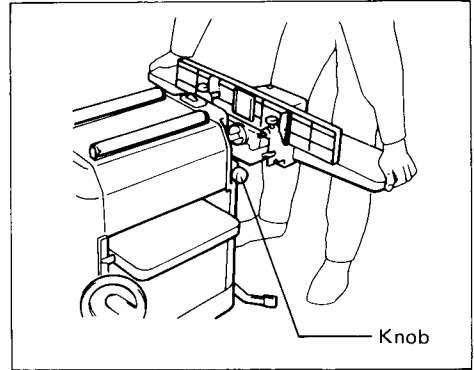

When the jointer is removed, the pulley cover will close automatically. If you lock the pulley cover in the open position for some reason, be sure to close it by pushing the release button before operating the auto-planer. Never operate the auto-planer with the pulley cover locked in the open position.

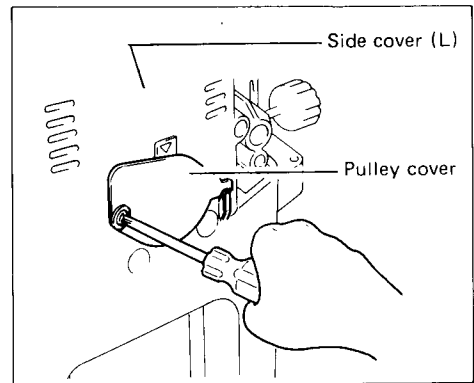

### 2. Installing the jointer

Open the pulley cover until it will be locked. Align the line on the pulley with the pointer on the side cover (L).

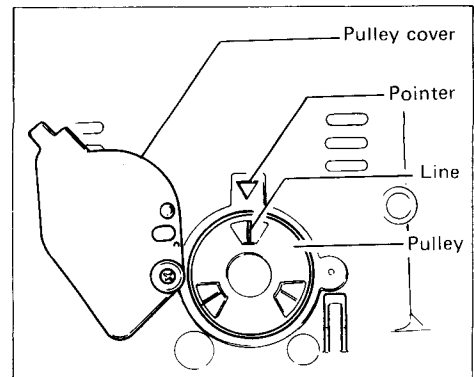

Loosen the clamp screws which secure the fence. Remove the fence. Align the line on the coupling with the pointer on the frame of the jointer.

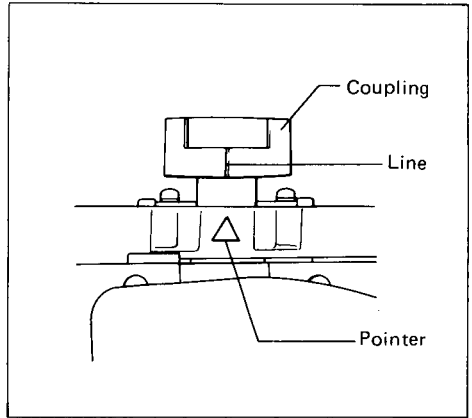

Align the two shafts of the jointer with the mating holes in the auto-planer. Push the jointer toward the auto-planer until the frame of the jointer contacts that of the auto-planer. Make sure the jointer is correctly installed on the auto-planer by viewing the contact portion through the notch. Tighten the knobs to secure the jointer. Re-install the fence and tighten the clamp screws to secure the fence.

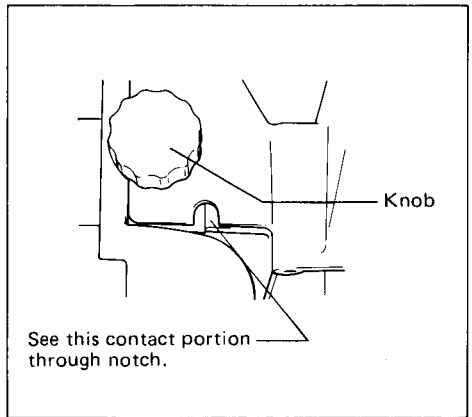
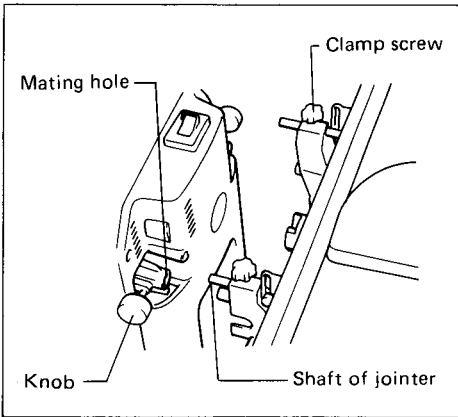

## MAINTENANCE

### CAUTION:

Always be sure that the tool is switched off and unplugged before attempting to perform inspection or maintenance.

### Replacing carbon brushes

Remove and check the carbon brushes regularly. Replace when they wear down to the limit mark. Keep the carbon brushes clean and free to slip in the holders. Both carbon brushes should be replaced at the same time. Use only identical carbon brushes.

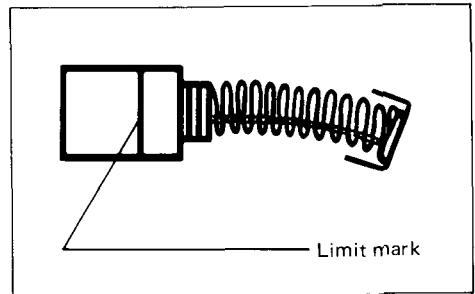

Open the chip cover and remove the brush holder caps using a screwdriver. Take out the worn carbon brushes, insert the new ones and secure the brush holder caps.

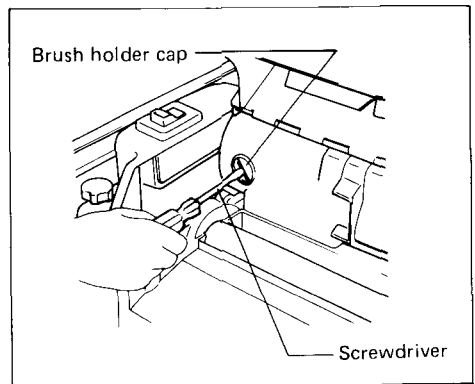

### Lubrication

Oil the chain (after removing the side cover R), the column moving parts (contact areas) and the crank handle. This periodic lubrication should be performed with machine oil.

### CAUTION:

Oiling and all maintenance should be done with the tool turned off and unplugged.

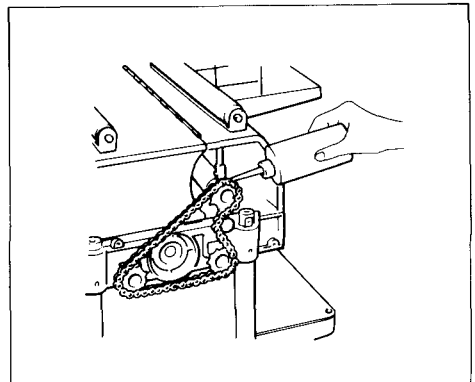

To maintain product SAFETY and RELIABILITY, repairs, any other maintenance and adjustment should be performed by Makita Authorized or Factory Service Centers, always using Makita replacement parts only.

# ACCESSORIES

## ATTENTION:

These accessories or attachments are recommended for use with your Makita tool specified in this manual. The use of any other accessories or attachments might present a risk of injury to persons. The accessories or attachments should be used only in the proper and intended manner.

### ● Planer blade



Part No.	Size (mm)
B-02864	155 (6-1/8")
B-02870	312 (12-9/32")

### ● Magnetic holder

Part No. 762017-8



### ● Key

Part No.



### ● Socket wrench 9

Part No. 782203-5

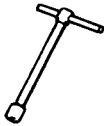

### ● Screwdriver

Part No. 783002-8

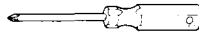

### ● Triangular rule

Part No. 762001-3



### ● Hood set

(For auto-planer)

Part No. 192382-5



### ● Hood set

(For jointer)

Part No. 192383-3

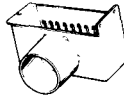

### ● Y joint assembly

Part No. 122342-3

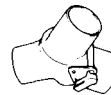

### ● Extension support table

Part No. 192381-7

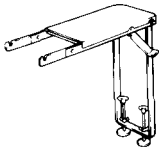

### ● Push block

Part No. 155508-0



# 312 mm (12-9/32") PLANER-JOINTER Model 2030S

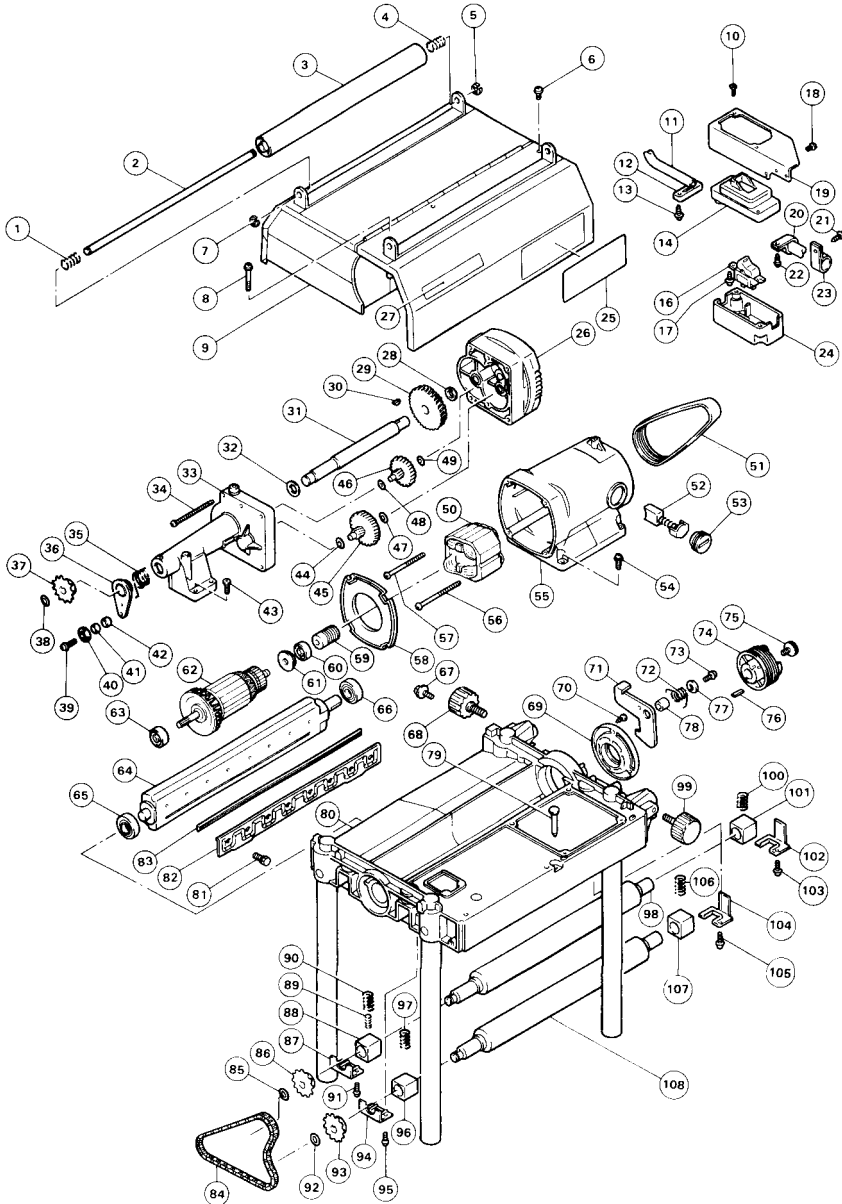

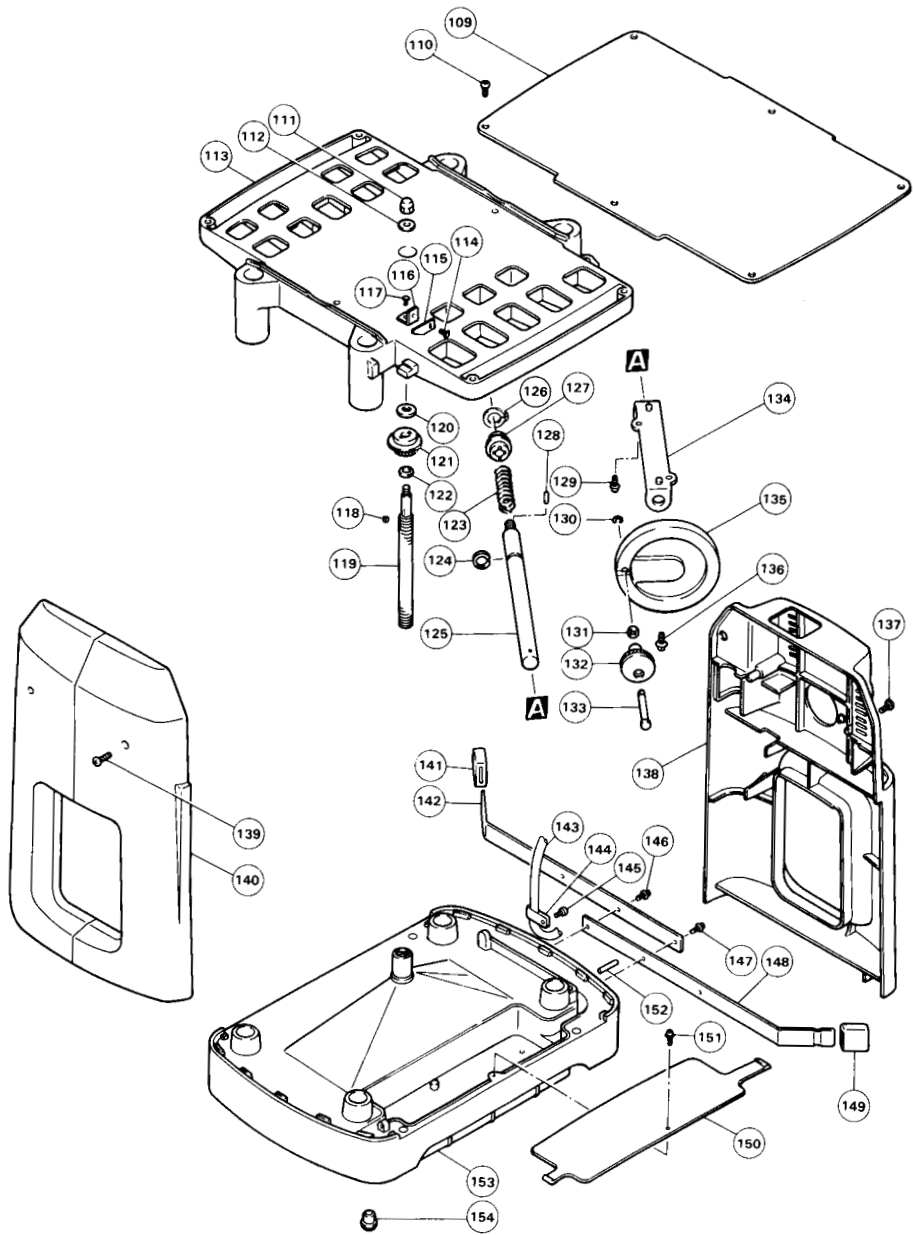



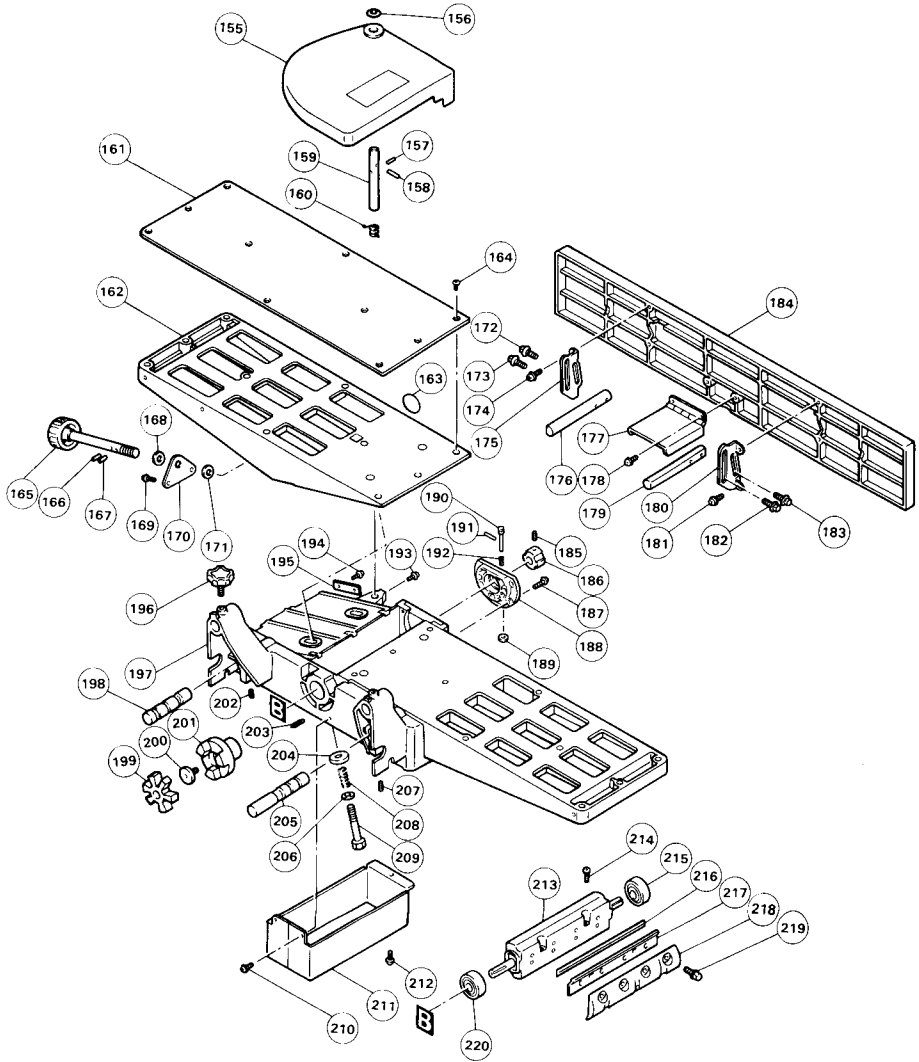

Note: The switch and other part configurations may differ from country to country.

ITEM NO.	NO. USED	DESCRIPTION	ITEM NO.	NO. USED	DESCRIPTION
<b>MACHINE</b>			<b>MACHINE</b>		
1	2	Compression Spring 14	74	1	V-Pulley 9-58
2	2	Roller Shaft	75	1	Hex. Socket Head Bolt M6x12
3	2	Roller 29-300	76	1	Key 4
4	2	Compression Spring 14	77	1	Flat Washer 6
5	2	Stop Ring E-6	78	1	Sleeve 5
6	2	Pan Head Screw M5x16 (With Washer)	79	1	Gauge
7	2	Stop Ring E-6	80	1	Main Frame
8	1	Pan Head Screw M5x60 (With Washer)	81	16	Hex. Flange Head Bolt M6x17
9	1	Chip Cover	82	2	Set Plate 310
10	2	Countersunk Head Screw M4x30	84	1	Chain 35-50
11	1	Tube 10-10.8-15	85	1	Retaining Ring S-12
12	1	Strain Relief	86	1	Sprocket 12
13	2	Tapping Screw 4x18	87	1	Metal Cover (B)
14	1	Switch Box	88	1	Plane Bearing 17
16	1	Switch	89	1	Compression Spring 7
17	2	Tapping Screw Blind PT3x8	90	1	Compression Spring 13
18	1	Tapping Screw.Flange.PT4x12	91	2	Hex. Socket Head Bolt M5x16 (With Washer)
19	1	Switch Supporter	92	1	Retaining Ring S-12
20	1	Strain Relief	93	1	Sprocket 12
21	1	Tapping Screw.Flange.PT4x12	94	1	Metal Cover (B)
22	1	Tapping Screw.Flange.PT4x12	95	2	Hex. Socket Head Bolt M5x16 (With Washer)
23	1	Strain Relief	96	1	Plane Bearing 17
24	1	Switch Box Cover	97	1	Compression Spring 13
25	1	Name Plate	98	1	Roller 34-295
26	1	Gear Housing	99	1	Knob 40
27	1	Makita Label	100	1	Compression Spring 13
28	1	Flat Washer 12	101	1	Plane Bearing 17
29	1	Helical Gear 45	102	1	Metal Cover (A)
30	1	Woodruff Key 4	103	2	Hex. Socket Head Bolt M5x16 (With Washer)
31	1	Drive Shaft	104	1	Metal Cover (A)
32	1	Flat Washer 14	105	2	Hex. Socket Head Bolt M5x16 (With Washer)
33	1	Gear Housing Cover	106	1	Compression Spring 13
34	4	Pan Head Screw M5x85 (With Washer)	107	1	Plane Bearing 17
35	1	Torsion Spring 23	108	1	Roller 34-295
36	1	Tensioner	109	1	Table Plate
37	1	Sprocket 12	110	6	Countersunk Head Screw M4x12
38	1	Retaining Ring S-12	111	1	Hex. Lock Nut M8-13
39	1	Pan Head Screw M5x20 (With Washer)	112	1	Flat Washer 8
40	1	Tension Roller	113	1	Table
41	1	Plane Bearing 5	114	1	Pan Head Screw M5x8 (With Washer)
42	1	Ring 6	115	1	Indicator
43	2	Pan Head Screw M5x25 (With Washer)	116	1	Set Plate
44	1	Flat Washer 8	117	1	Pan Head Screw M5x8 (With Washer)
45	1	Gear Complete 8-44	118	1	Woodruff Key 3
46	1	Gear Complete 8-47	119	1	Screw M16
47	1	Flat Washer 8	120	1	Thrust Needle Bearing 1023
48	1	Flat Washer 6	121	1	Straight Bevel Gear 16
49	1	Flat Washer 6	122	1	Flat Washer 10
50	1	Field	123	1	Compression Spring 15
51	1	Poly V-Belt 9 - 374	124	1	Stop Ring E-12
52	2	Carbon Brush	125	1	Handle Shaft
53	2	Brush Holder Cap	126	1	Retaining Ring S-10
54	2	Pan Head Screw M5x25 (With Washer)	127	1	Straight Bevel Gear 16
55	1	Motor Housing	128	1	Spring Pin 4-18
56	1	Pan Head Screw M5x80 (With Washer)	129	2	Pan Head Screw M5x16 (With Washer)
57	1	Pan Head Screw M5x80 (With Washer)	130	1	Stop Ring E-6
58	1	Baffle Plate	131	1	Flat Washer 8
59	1	V-Pulley 9-25L	132	1	Knob 45
60	1	Ball Bearing 6200DDW	133	1	Pin 8
61	1	Insulation Washer	134	1	Handle Supporter
62	1	Armature	135	1	Handle 125
63	1	Ball Bearing 6200DDW	136	1	Hex. Flange Head Bolt M5x10
64	1	Main Drum	137	2	Pan Head Screw M5x30 (With Washer)
65	1	Ball Bearing 6202LLB	138	1	Side Cover L
66	1	Ball Bearing 6202LLB	139	2	Pan Head Screw M5x30 (With Washer)
67	1	Hex. Flange Head Bolt M5x10	140	1	Side Cover R Complete
68	1	Knob 40	141	1	Foot
69	1	Bearing Box	142	1	Leg
70	3	Countersunk Head Screw M5x16	143	1	Cord
71	1	Lock Plate	144	1	Strain Relief
72	1	Torsion Spring 12	145	1	Pan Head Screw M4x12 (With Washer)
73	1	Pan Head Screw M5x25 (With Washer)	146	1	Hex. Flange Head Bolt M6x17

ITEM NO.	NO. USED	DESCRIPTION	ITEM NO.	NO. USED	DESCRIPTION
<b>MACHINE</b>			<b>MACHINE</b>		
147	1	Hex. Flange Head Bolt M6x17	184	1	Ruler
148	1	Leg	185	1	Set Screw M5x8
149	1	Foot	186	1	Lock Sleeve
150	1	Base Cover	187	4	Pan Head Screw M5x16 (With Washer)
151	1	Pan Head Screw M5x16 (With Washer)	188	1	Bearing Cover
152	4	Spring Pin 6-36	189	1	Nut M4-12
153	1	Base	190	1	Stopper Pin
154	4	Cap 20	191	1	Pin 2
155	1	Drum Cover	192	1	Compression Spring 5
156	1	Retaining Ring S 12	193	1	Hex. Flange Head Bolt M5x10
157	1	Spring Pin 4-16	194	2	Pan Head Screw M5x8 (With Washer)
158	1	Spring Pin 4-32	195	1	Scale Plate
159	1	Rod 12-95	196	2	Screw M6x19
160	1	Torsion Spring 14	197	1	Fix Bed
161	2	Bed Plate	198	1	Rod 17-63
162	1	Adjust Bed	199	1	Coupling Cushion
163	1	Indication Label	200	1	Hex. Socket Head Bolt M6x12
164	20	Countersunk Head Screw M4x12	201	1	Coupling
165	1	Knob 40	202	1	Set Screw M5x12
166	1	Spring Pin 4-18	203	1	Key 4
167	1	Spring Pin 4-18	204	2	Cup Washer 8
168	1	Flat Washer 10	205	1	Rod 17-90
169	2	Pan Head Screw M5x16 (With Washer)	206	2	Flat Washer 8
170	1	Screw Holder	207	1	Set Screw M5x12
171	1	Flat Washer 10	208	2	Compression Spring 9
172	1	Hex. Flange Head Bolt M6x17	209	2	Hex. Socket Head Bolt M8x50
173	1	Hex. Flange Head Bolt M6x17	210	2	Pan Head Screw M5x16 (With Washer)
174	2	Pan Head Screw M5x16 (With Washer)	211	1	Chip Guide
175	1	Rule Holder L	212	1	Pan Head Screw M5x16 (With Washer)
176	1	Ruler Bar	213	1	Sub Drum
177	1	Safety Cover	214	4	Flat Head Screw M5x13
178	2	Pan Head Screw M5x16 (With Washer)	215	1	Ball Bearing 6200DDW
179	1	Ruler Bar	217	2	Set Plate 155
180	1	Rule Holder R	218	2	Drum Plate
181	2	Pan Head Screw M5x16 (With Washer)	219	8	Hex. Flange Head Bolt M6x17
182	1	Hex. Flange Head Bolt M6x17	220	1	Ball Bearing 6201DDW
183	1	Hex. Flange Head Bolt M6x17			

Note: The switch and other part specifications may differ from country to country.

## MAKITA LIMITED ONE YEAR WARRANTY

### Warranty Policy

Every Makita tool is thoroughly inspected and tested before leaving the factory. It is warranted to be free of defects from workmanship and materials for the period of ONE YEAR from the date of original purchase. Should any trouble develop during this one-year period, return the COMPLETE tool, freight prepaid, to one of Makita's Factory or Authorized Service Centers. If inspection shows the trouble is caused by defective workmanship or material, Makita will repair (or at our option, replace) without charge.

This Warranty does not apply where:

- repairs have been made or attempted by others:
- repairs are required because of normal wear and tear:
- The tool has been abused, misused or improperly maintained;
- alterations have been made to the tool.

IN NO EVENT SHALL MAKITA BE LIABLE FOR ANY INDIRECT, INCIDENTAL OR CONSEQUENTIAL DAMAGES FROM THE SALE OR USE OF THE PRODUCT. THIS DISCLAIMER APPLIES BOTH DURING AND AFTER THE TERM OF THIS WARRANTY.

MAKITA DISCLAIMS LIABILITY FOR ANY IMPLIED WARRANTIES, INCLUDING IMPLIED WARRANTIES OF "MERCHANTABILITY" AND "FITNESS FOR A SPECIFIC PURPOSE," AFTER THE ONE-YEAR TERM OF THIS WARRANTY.

This Warranty gives you specific legal rights, and you may also have other rights which vary from state to state. Some states do not allow the exclusion or limitation of incidental or consequential damages, so the above limitation or exclusion may not apply to you. Some states do not allow limitation on how long an implied warranty lasts, so the above limitation may not apply to you.

**Makita Corporation**

3-11-8, Sumiyoshi-cho,  
Anjo, Aichi 446 Japan